



**Calhoun: The NPS Institutional Archive**  
**DSpace Repository**

---

Departments, Schools and Academic Groups Publications      Schools, Departments and Academic Groups Publications (Other)

---

1996-11

# Proceedings of the Technology and the Mine Problem Symposium, vol II of II

Monterey, California: Naval Postgraduate School

---

<https://hdl.handle.net/10945/57402>

---

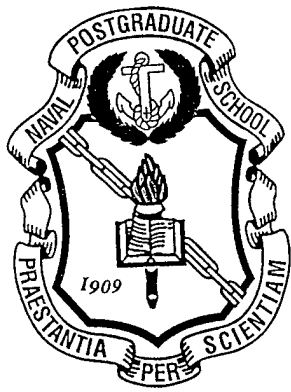
*Downloaded from NPS Archive: Calhoun*



Calhoun is the Naval Postgraduate School's public access digital repository for research materials and institutional publications created by the NPS community. Calhoun is named for Professor of Mathematics Guy K. Calhoun, NPS's first appointed -- and published -- scholarly author.

**Dudley Knox Library / Naval Postgraduate School**  
**411 Dyer Road / 1 University Circle**  
**Monterey, California USA 93943**

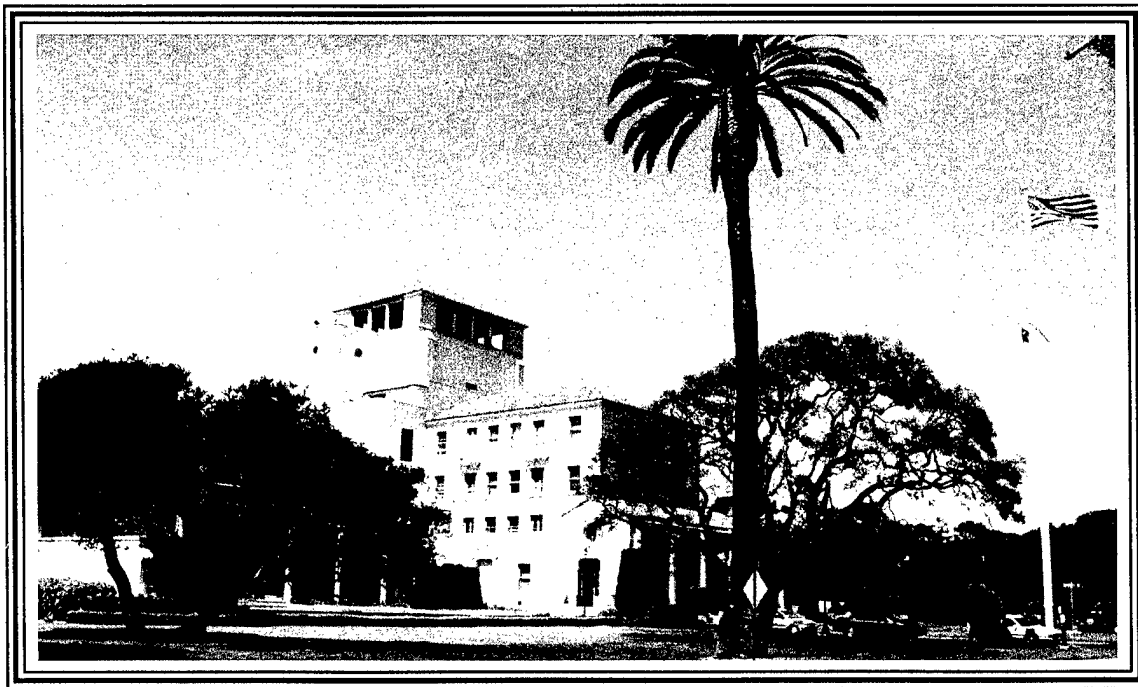
<http://www.nps.edu/library>



*Volume II of II*

*Proceedings of the*

*Technology and the  
Mine Problem  
Symposium*



*18-21 November 1996*

*Naval Postgraduate School, Monterey, California*

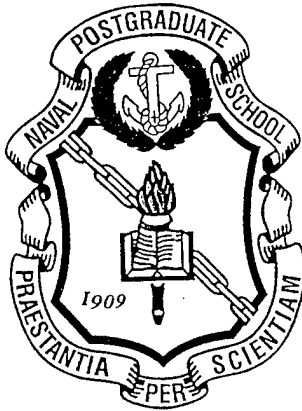
**DISTRIBUTION STATEMENT A**

Approved for public release  
Distribution Unlimited

DTIC QUALITY INSPECTED 1

19970624 031





*Welcome  
to the  
Naval Postgraduate School.*

Few post-Cold War challenges possess the urgency of the Mine Problem both in military and humanitarian terms. We at NPS are dedicated to the exploration of technical approaches to the solution of the Mine Problem. Your generous participation in this Symposium series underscores the community-wide appreciation of the urgency of this problem. Together, I feel certain we shall meet our objective of "changing the world."

The Faculty, Staff and Students of NPS stand ready to acquaint you further with this very special place. I sincerely hope that, while you are here, you will avail yourselves of the opportunities to get to know us, to see the possibilities in the Technology Transfer Program, and to forge professional networks to deal with the multi-faceted dimensions of the Mine Problem.

Marsha J. Evans  
Rear Admiral, United States Navy  
Superintendent

*Proceedings of the*

***Technology and the  
Mine Problem  
Symposium***

*Second in the Series  
of Sesquiannual Symposia*

*Edited by*

Professor Albert M. Bottoms  
Ellis A. Johnson Chair of Mine Warfare,  
Naval Postgraduate School  
Symposium General and Organizing Chair

Barbara Honegger, M.S.  
Symposium Program Coordinator  
and  
Proceedings Editor

***Volume II of II***



# ACKNOWLEDGEMENTS

An enterprise of the magnitude of the Symposium on Technology and the Mine Problem is a coordinated team effort amongst sponsors, speakers, schedulers, Session Chairs, symposium staff, and the attendees. The planning horizon for such a symposium is over one year for staff and presenters alike. On behalf the Mine Warfare Association, I extend thanks and appreciation to the following:

## **Navy Sponsors:**

Office of Naval Research: RADM Paul G. Gaffney II, USN, Chief of Naval Research; and  
Dr. Fred Saalfeld, Deputy Chief of Naval Research and Technical Director,  
Office of Naval Research  
Naval Postgraduate School: RADM Marsha J. Evans, USN, Superintendent; and  
Professor James N. Eagle, Chair, Undersea Warfare Academic Group

## **Corporate Sponsors (for the Session on the Littoral Environment at the Monterey Bay Aquarium):**

Office of Naval Research  
Raytheon  
Mercury Computers  
A&T Inc.  
TRACOR  
Lockheed-Martin, Inc.  
OmniTech Robotics  
ObjectTime Pacific LLC  
International Submarine Engineering (ISE), Inc.

## **Symposium Staff :**

Ms. Barbara Honegger, M.S., Program Coordinator and Proceedings Editor,  
ROLANDS & Associates  
Ms. Suzanne Wyatt and Ms. Melody Burgess, Destination Monterey/Carmel  
Dr. Joseph J. Molitoris, Secretary-Treasurer, Mine Warfare Association  
CDR John Peterson, USN (Ret)  
Dr. Robert F. Rowntree

## **Symposium Executive Committee, Naval Postgraduate School:**

Professor James N. Eagle, Operations Research  
Professor Anthony J. Healey, Mechanical Engineering  
Dr. Harrison C. Shull, former Provost  
Professor Xavier Maruyama, Physics  
Associate Professor Mitch Brown, National Security Affairs  
Dr. Don Brutzman, Undersea Warfare and Computer Science  
Mr. Albert M. Bottoms, Ellis A. Johnson Chair of Mine Warfare,  
President of the Mine Warfare Association, and General Chair  
of the Symposium

## **MINE LINES and THE MINE WARFARE ASSOCIATION (MINWARA)**

The Symposium Announcement and Registration Issues of MINE LINES were sent to an expanded mailing list. This was made possible by planning funds from the Office of Naval Research. The PROCEEDINGS of this Symposium will be mailed in February 1997 to each registrant as part of the Registration Fee.

The Mine Warfare Association (MINWARA) was formed as a Not-for-Profit Corporation in the Commonwealth of Virginia for the purposes of education and communication about Mine Warfare and the Mine Problem. MINWARA derives its support from Corporate and Individual Memberships. There is no subsidy for publication and mailing of MINE LINES. MINWARA lacks the resources to send MINE LINES to the 7,000 or more recipients of the Registration Issue.

MINE LINES is the Newsletter of the Mine Warfare Association. Through MINE LINES we seek to stimulate professional exchange and to announce the periodic workshops and meetings that MINWARA will sponsor and co-host. These events are in addition to the sesquiannual Symposium on Technology and the Mine Problem.

A Membership Application for the Mine Warfare Association is available in this Proceedings. Further information, and information on Corporate Membership classes and benefits, can be obtained from the MINWARA Secretary-Treasurer, Dr. Joseph Molitoris, at (703) 339-7244.

# TABLE OF CONTENTS

## *Volume I of II*

### PREFACE

Acknowledgements.....	iii
Table of Contents.....	v
Introduction.....	xix
Prof. Albert M. Bottoms	
Welcoming Remarks .....	xxvii
CAPT James M. Burin, USN	
Sponsors' Remarks.....	xxix
RADM Paul G. Gaffney II, USN; Dr. Fred E. Saalfeld; Dr. David Skinner	
Introductory Remarks.....	xxxii
Prof. Albert M. Bottoms	

### CHAPTER 1: THE CHALLENGE

Keynote Address	
GEN John J. Sheehan, USMC .....	1-1
Technology, the Budget and Politics	
ADM Stan Arthur, USN (Ret) .....	1-35
Technology and the Mine Problem: An Evolutionary Revolution .....	1-39
Prof. Albert M. Bottoms	

### CHAPTER 2: OPERATIONAL REQUIREMENTS AND PERSPECTIVES

Introduction .....	2-1
U.S. Army Initiatives in Mine Warfare .....	2-3
MGEN Clair F. Gill, USA (Personal Representative of GEN W. Hartzog, USA)	
An Entirely New Approach to the Countermine Mission .....	2-29
COL Robert Greenwalt, Jr., USA	
U.S. Air Force Roles in Mine Warfare .....	2-79
COL Leroy Barnidge, USAF (Personal Representative of LTGEN Phillip E. Ford, USAF)	
U.S. Marine Corps Perspectives on Technology and the Mine Problem.....	2-89
LTGEN Jefferson Davis Howell, Jr., USMC	

U.S. Navy Perspectives on the Present and Future of Mine Warfare .....	2-97
RADM Dennis R. Conley, USN	
The Future of the Pacific Fleet .....	2-119
RADM John F. Sigler, USN	
The Joint Mine Countermeasures/Countermine Advanced Concepts Technology Demonstration (ACTD) Process .....	2-139
Mike Jennings, Doug Todoroff	
The Importance of Keeping Historical Records Available in Mine Warfare .....	2-145
Tamara Melia Smith	
Developments in Marine Corps Mine Warfare .....	2-153
MAJGEN John E. Rhodes, USMC	

### **CHAPTER 3: OPERATIONAL ENVIRONMENTS AND THREATS**

Introduction .....	3-1
Mine Clearance in the Real World .....	3-3
MAJ Colin King, British Army (Ret)	
The Anti-Personnel Mine Threat.....	3-11
Harry N. (Hap) Hambric, William C. Schneck	
The Proliferation of the Mine Threat and the PRORYV System .....	3-47
Victor Newton, Terry Kasey	
Session on the Littoral Environment at the Monterey Bay Aquarium .....	3-51
Developments in Rapid Environmental Assessment .....	3-53
RADM Paul E. Tobin, USN	
Developments in the Very Shallow Water - Mine Countermeasures Test Detachment Program .....	3-57
CAPT Thomas R. Bernitt, USN	

## **CHAPTER 4: LANDMINES AND HUMANITARIAN DEMINING**

Introduction .....	4-1
The History and Future of U.S. Policy on a Universal Anti-Personnel Landmine Ban.....	4-5
The Hon. H. Allen Holmes, Assistant Secretary of Defense, SOLIC	
Humanitarian Demining and Mine Policy: Chair’s Opening Remarks.....	4-21
Prof. Fred Mokhtari	
An Open Letter to President Clinton.....	4-23
Signed and Submitted by LTGEN Robert C. Gard, USA (Ret)	
Seeking Real Solutions to the Landmine Problem.....	4-25
Robert Sherman, U.S. Arms Control and Disarmament Agency	
Banning Anti-Personnel Landmines.....	4-27
Stephen D. Goose, Human Rights Watch	
Technology and Humanitarian Demining .....	4-31
Garth Barrett	
Bringing New Technology to Bear on Landmine Detection: The Role of NGOs as Catalysts and Liaisons Between Technology Providers and Mine-Affected Countries.....	4-35
Richard M. Walden	
Research and Development in Support of Humanitarian Demining: Meeting the Landmine Challenge .....	4-39
Harry M. (Hap) Hambric, Beverly D. Briggs, Thomas L. Henderson	
Command Communications Video and Light System (CCVLS) .....	4-51
Sean Patrick Burke	
Cooperation in Europe for Humanitarian Demining .....	4-57
Prof. J. D. Nicoud	
Post-Conflict and Sustainable Humanitarian Demining .....	4-63
Prof. J. D. Nicoud	
Minefield Proofing and Route Clearing in Bosnia Using Unmanned Ground Vehicles and the Standardized Teleoperation System .....	4-67
David W. Parish, LTC Jon Moneyhun	



Multi Sensor Vehicular Mine Detection Testbed for Humanitarian Demining .....	4-73
Douglas Brown, Joseph Bendahan, Giancarlo Borgonovi, Delmar Haddock, Jason Regnier	
Tele-Operated Ordnance Disposal System for Humanitarian Demining .....	4-79
Jason Regnier, Joseph Foley	
Mine Marking and Neutralization Foam.....	4-87
Steven Tunick, Jason Regnier	
The Development of a Multimedia Electronic Performance Support System for Humanitarian Demining .....	4-95
William C. Schneck, Amos (Sam) L. Samuel	
LEXFOAM for Humanitarian Demining .....	4-99
C. John Anderson, Joseph L. Trocino	
 <b>CHAPTER 5: PROGRESS IN AUTONOMOUS SYSTEMS FOR MINE WARFARE</b>	
Introduction .....	5-1
The Basic UXO Gathering System (BUGS) Program for Unexploded Ordnance Clearance and Minefield Countermeasures: An Overview and Update.....	5-3
Christopher DeBolt, Christopher O'Donnell	
Small Autonomous Robotic Technician .....	5-11
Bryan Koontz, Charles Tung, Ely Wilson	
Enabling Techniques for Swarm Coverage Approaches.....	5-23
Helen Greiner, Colin Angle, Joseph L. Jones, Art Sheckman, Richard Myers	
Control of Small Robotic Vehicles in Unexploded Ordnance Clearance .....	5-37
A. J. Healey, Y. Kim	
Unexploded Ordnance Clearance and Minefield Countermeasures By Multi-Agent, Small Robotics .....	5-43
Craig Freed, Tuan Nguyen	
DARPA's Autonomous Minehunting and Mapping Technologies (AMMT) Program .....	5-63
Claude P. Brancart	

GPS and Mine Warfare .....	5-73
James R. Clynch	
The <i>Phoenix</i> Autonomous Underwater Vehicle .....	5-79
Don Brutzman, Tony Healey, Dave Marco, Bob McGhee	
A Small Co-Axial Robotic Helicopter for Autonomous Minefield Search and Destroy Missions .....	5-101
Charles Colby	
Fully Autonomous Land Vehicle for Mine Countermeasures .....	5-109
Raymond C. Daigh	
Advanced Technology: It's Available at JPL .....	5-121
James R. Edberg	
Mission Planning for an Autonomous Undersea Vehicle: Design and Results .....	5-125
Michael J. Ricard	
An Integrated Ground and Aerial Robot System for UXO/Mine Detection .....	5-135
Yutaka J. Kanayama, Isaac Kaminer, Xiaoping Yun, Xavier Maruyama, Nelson Ludlow	
The Coastal Battlefield Reconnaissance and Analysis (COBRA) Program For Minefield Detection .....	5-141
Ned H. Witherspoon, Bob Muise, James A. Wright	
Clandestine Mine Reconnaissance: Unmanned Undersea Vehicles .....	5-149
CAPT Charlie B. Young, USN	
The <i>Iguana</i> : A Mobile Substitute for Landmines .....	5-179
John Arquilla, Barbara Honegger	
Mission Definition for AUVs for War Gas Ammunition Deposit Assessment.....	5-181
Marek Narewski, Leszek Matuszewski	
The Lemmings/BUGS System .....	5-189
Arnis Mangolds	
Application of the Explosive Ordnance Disposal Robotic Work Package to the Clearance of Terrestrial Improved Conventional Munitions (AutoRECORM).....	5-191
Gary M. Trimble	

## **CHAPTER 6: COUNTERING MINES ON LAND**

Introduction .....	6-1
Systems and Technologies for Countering Mines on Land .....	6-3
Col Robert Greenwalt, Jr., USA	
GPR and Metal Detector Portable System .....	6-27
Prof. J. D. Nicoud	
Mine Detection with Modern Day Metal Detectors .....	6-33
Gerhard Vallon	
Technology Assessment of Passive Millimeter Wave Imaging Sensor for Standoff Airborne Mine Detection .....	6-39
Brad Blume, Sam Taylor, Jack Albers, Ned H. Witherspoon	
DARPA's Hyperspectral Mine Detection Program .....	6-51
C.J. Sayre, D.J. Fields, A.P. Bowman, A.L. Giles, E.M. Winter, F.J. Badik, M.J. Schlangen, P.G. Lucey, T.J. Williams, J.R. Johnson, J. Hinrichs, K.A. Horton, G. Allen, A.D. Stocker, A. Oshagan, W. Schaff, W. Kendall, M.R. Carter, C.L. Bennett, W.D. Aimonetti	
On the Feasibility of Microwave Imaging of Buried Landmines at a Modest Stand-off Distance .....	6-57
J.T. Nilles, G. Tricoles, G.L. Vance	
Chemical Systems for In-Situ Neutralization of Landmines in Peacetime .....	6-61
Divyakant Patel, Beverly Briggs, Allen Tulis, James Austing, Remon Dihu, Alan Snelson	
Radar Imaging Experiments for Landmine Detection .....	6-67
Stephen G. Azevedo, J.E. Mast, E.T. Rosenbury	
Ultra-Wideband, Short Pulse Ground-Penetrating Radar: Theory and Measurement .....	6-69
Lawrence Carin, Stanislav Vitebskiy, Marc Ressler, Francis Le	

# *Volume II of II*

## **CHAPTER 7: TECHNOLOGIES FOR COUNTERING MINES AT SEA**

Introduction .....	7-1
The Underwater Influence Fields of Target Ships: Some Mine Sensor System Considerations and the Strengths and Weaknesses of Influence Mine Sweeping .....	7-3
Dennis R. Hiscock, Royal Navy, U.K. (Ret)	
Pervasive Technical Issues Related to Organic Mine Countermeasures .....	7-15
John Richard Benedict, Jr.	
Identification of Underwater Mines via Surface Acoustic Signature .....	7-47
Dale A. Lawrence, Renjeng Su, and Nouredine Kermiche	
Advances in the Magnetic Detection and Classification of Sea Mines and Unexploded Ordnance .....	7-53
Ted R. Clem	
Passive Mine Detection .....	7-67
Charles H. Dabney	
Autonomous Detection and Classification of Bottom Objects with Multi-Aspect Sonar...	7-69
Robert W. Floyd, John E. Sigurdson	
A Neural Network Approach to the Detection of Buried Objects in Seafloors .....	7-85
Raj Mittra	
Free Surface Slope Signature of Moored Mines in a Current: Experimental Results .....	7-89
P.M. Smith	
Seismo-Acoustic Sonar for Buried Object Detection .....	7-99
Thomas G. Muir, D. Eric Smith, Preston S. Wilson	
Portable Turnkey UXO Detection System.....	7-105
Gerhard Vallon, Okkar Dietz	
Rapid Response: A Demonstration of Rapid Environmental Assessment Technologies for Mine Warfare .....	7-109
William Roderick	
SLICE: A Stable Reconfigurable Platform, a New MCM Opportunity .....	7-113
Steven Loui, Terry Schmidt	

Rapid Response Minesweeping .....	7-123
Carl Fisher	
Implications of Single-Point, Mobile-Charge and Distributed Wide-Area Architectures for Mine Warfare .....	7-125
Walter E. Dence, Jr.	
History and Evolution of Minehunting Technology .....	7-129
Celeste Z. Hansel	
MCM Applications of a Virtual Environment-Based Training System for ROV Pilots...	7-137
Barbara Fletcher	
Clandestine Reconnaissance in Very Shallow Water with a Mine Reconnaissance Underwater Vehicle .....	7-145
CAPT Dan Hendrickson, USN (Ret)	
The First Mine Countermeasure Devices with Superconducting Magnets .....	7-183
Vladimir Karasik, Gennady Agapov, George Kurlijandtsev, Vladimir Tsikhon, Vladimir Malginov, Anatoly Rusinov, Valentine Matokhin, Michael Sidorov, Alex Konjukhov, Vitaly Vysotsky	
Acoustic Time Series Simulator (ATSS) Synthetic Environment Applied to Mine Warfare.....	7-191
J. W. Kesner	
Automated Mine Identification Using Wavelet Analyzing Functions .....	7-199
Mark E. Lehr, Keh-Shin Lii	
Acoustic Characterization of Seagrasses and their Effects on Mine-Hunting Sonars....	7-209
Elena McCarthy	
New Technologies for the Military: Mine Warfare as a Test Case .....	7-215
Joseph J. Molitoris	
D8 Tractor/Israeli Mine Plow (IMP) Mine and Obstacle Clearance Testing .....	7-233
John P. Wetzel	
Reduced Wavenumber Synthetic Aperture for MCM Applications .....	7-241
Ira Ekhaus	

Mine Burial Experiments in Carbonate Sediments .....	7-253
Daniel F. Lott, Kevin L. Williams, Darrell R. Jackson	
Buried Target Image Quality .....	7-263
Nicholas P. Chotiros	
Clutter Sensitivity Test Under Controlled Field Conditions .....	7-269
Larry Stolarczyk, Joseph M. Mack	
Analysis and Time Frequency Processing of Scattered Signals from Submerged Mines in Shallow Water .....	7-319
Lawrence Carin, Marc McClure	
Imaging Small Scatterers in Shallow Water from Towed Array Data .....	7-321
Meng Xu, Norman Bleistein	
Development of a Conductively-Cooled Superconducting Magnet System for Mine Countermeasures .....	7-323
E. Michael Golda	
The Continuous Improvement Process .....	7-325
RADM Richard D. Williams III, USN, PEO Mine Warfare	

**CHAPTER 8: ALTERNATIVE APPROACHES TO MINE CLEARANCE,  
TECHNOLOGIES FOR OBSTACLES AND THE SURF ZONE**

Introduction.....	8-1
Coordination of Department of Defense Efforts for the Disposal of Unexploded Ordnance .....	8-3
Christopher O'Donnell	
Surf Zone Technology: Enabling Operational Maneuver from the Sea .....	8-13
Daniel A. Crute	
<i>Thunder Road</i> : Ballistically Delivered Distributed Explosive Nets .....	8-21
Donald Robeson, Michael Farinella, Arnis Mangolds	
Explosive Neutralization Techniques .....	8-27
Les Taylor	

Pulse Power: 21st Century Platform Defense for Mines and Torpedoes .....	8-53
RADM Charles F. Horne III, USN (Ret)	
Is the Application and Utilization of All the Required Skills Being Applied Within the Mechanical Mine Clearance Arena? .....	8-57
William N. Baker	
Alternative Approaches to Minesweeping and Mine Clearance .....	8-61
Warren Loughmiller	
Application of Seismic Vibration Concepts for Rapid Mine Clearance and Detection....	8-65
Geoffrey C. Davis, Steve Ballinger	
LCAC Autonomous Algorithms .....	8-83
Jaime Bunczek	
Rigid Polyurethane Foam Technology for Countermine (Sea) Program .....	8-91
R. L. Woodfin	
‘MODS’ - Mobile Ordnance Disrupter System .....	8-103
Owen Hofer	
In-Stride Mine and Obstacle Breaching for Amphibious Assaults .....	8-105
Rudy Wiley, Kris Irwin, Tim Hennessey, Phong Nguyen, Eric Scheid	
Man-Portable Mine Clearing Line Charge System .....	8-107
Michael Voisine, A. Jonathan Bawabe	
Mine Vulnerability .....	8-109
Joel Gaspin	
Bombs for Clearing .....	8-111
Ferrell W. Furr, Reid McKeown	
Deployment Modeling .....	8-113
Kennard Watson, Thai Nguyen	

## **CHAPTER 9: THE UNDERLYING SCIENCE OF MINE WARFARE SYSTEMS**

Introduction.....	9-1
Automated Task Division and Group Behavior in Autonomous Robots .....	9-3
Maja J. Mataric	
The Physics of Magnetic Signatures.....	9-5
Carl S. Schneider	
Sensors and Sensory Fusion for Minefield Surveillance and Reconnaissance .....	9-11
Ruzena Bajcsy, Max Mintz	
The Use of Ocean Optical Data to Predict the Performance of Mine Detecting	
Ocean Lidar Systems .....	9-49
R. Norris Keeler	
The Mechanics and Control of Biomimetic Robotic Locomotion .....	9-79
Joel Burdick, Bill Goodwine, Jim Ostrowski	

## **CHAPTER 10: SOME ANALYTICAL AND SIMULATION RESULTS**

Introduction .....	10-1
Evaluation of Intelligent Minefields .....	10-3
John A. Marin, Donald R. Barr	
Evaluation of AUV Search Tactics for Rapid Minefield Traversal Using	
Analytic Simulation and a Virtual World.....	10-21
Don Brutzman, Bryan Brauns, Paul Fleischman, Tony Lesperance, Brian Roth, Forrest Young	
Transition and R&D Recommendations Resulting from the MCM Tactical	
Environmental Data System (MTEDS) Program .....	10-35
Samuel G. Tooma, Daniel F. Lott	
Littoral Remote Sensing .....	10-45
Frank L. Herr, CAPT Dennis Ryan, USN, J.M. McDonald	



A Network-Centric Information Systems Architecture.....10-47  
Rex Buddenberg, LT Steve Graves, USN

Information Warfare and the Countermine Problem .....10-57  
Edward C. Gough, Jr., Robert L. Barrett

## **CHAPTER 11: PRESERVING THE MINE/COUNTERMINE EXPERIENCE**

Introduction .....11-1

Lessons Learned and Operational Experience in Mine Warfare at Sea .....11-3  
Frank Uhlig, Jr.

Process Challenges and Examples: A Reality Check .....11-11  
Tamara Melia Smith

NSAP and Operational Experience .....11-23  
Susan L. Bales, J. Charles Wicke

Mine Countermeasures Exercise Analysis: A Historical Review .....11-51  
George W. Pollitt

Development History of the Family of Destroyers .....11-57  
Charles A. Rowzee

MIREM Goals and Exercises: Past, Present and Future.....11-73  
LCDR Frank Daggett, USN

## **CHAPTER 12: ACQUISITION AND MARKET STRATEGY ISSUES**

Introduction .....12-1

Precis of Remarks by Mr. Ed Zdankiewicz, Deputy Assistant Secretary of the Navy  
for Undersea Warfare .....12-3  
Prof. Albert M. Bottoms

Identifying and Sizing the Mine Warfare Market: Summary Overview of Roundtable.....12-5  
Ric Trotta, with Comments by Ron Blue

<b>APPENDIX A:</b>	<b>A TUTORIAL BRIEF: The Technological Revolution in the Mine Problem, including Bibliographies on Naval Mines and Landmines.....</b>	<b>A-1</b>
	Prof. Albert M. Bottoms	
<b>APPENDIX A-1:</b>	<b>BIBLIOGRAPHY ON SEA MINES AND COUNTERMEASURES, 1970-1996.....</b>	<b>A1-1</b>
	Greta E. Marlatt, Michael Lee Huygen	
<b>APPENDIX A-2:</b>	<b>BIBLIOGRAPHY ON LAND MINES AND DEMINING, 1970-1996.....</b>	<b>A2-1</b>
	Michael Lee Huygen, Greta E. Marlatt	
<b>APPENDIX A-3:</b>	<b>BIBLIOGRAPHY ON MINE WARFARE.....</b>	<b>A3-1</b>
	Richard Hansen	
<b>APPENDIX B:</b>	<b>1996 SYMPOSIUM SPEAKERS AND ATTENDEES.....</b>	<b>B-1</b>
	(Names and contact information)	
<b>APPENDIX C:</b>	<b>MINE WARFARE ASSOCIATION INFORMATION AND MEMBERSHIP APPLICATION.....</b>	<b>C-1</b>
<b>APPENDIX D:</b>	<b>INTERNET SITES.....</b>	<b>D-1</b>
	< <a href="http://www.minwara.org">http://www.minwara.org</a> >	
	< <a href="http://www.demining.brtrc.com">http://www.demining.brtrc.com</a> >	
<b>STANDARD FORM 298.....</b>		<b>Final Page</b>



# INTRODUCTION

**Professor Albert M. Bottoms**  
Naval Postgraduate School

This volume contains the PROCEEDINGS and contributed papers of the Second Symposium on Technology and the Mine Problem, held at the Naval Postgraduate School November 18-21, 1996. The First Symposium, entitled Symposium on Autonomous Vehicles in Mine Countermeasures, was held at the School in April 1995.

This Second Symposium was dedicated to the memory of Admiral Jeremy "Mike" Boorda, USN, the former Chief of Naval Operations, who was a staunch supporter of efforts to harness technology to deal with the Mine Problem.

The Honorary Chair of this Second Symposium was Rear Admiral John D. Pearson, USN, the outgoing Commander of the U.S. Navy Mine Warfare Command.

The Organizing and General Chair of the Symposium was Albert M. Bottoms, Ellis A. Johnson Chair of Mine Warfare at the Naval Postgraduate School and President of the Mine Warfare Association.

## VISION STATEMENT

The vision for evolving mine countermeasures/countermine systems is that of a family or families of affordable, autonomous systems capable of carrying out the tasks associated with the management of risks from mines in the military contexts or clearance assurance in the humanitarian de-mining context. In practice, autonomy will likely be a matter of degree -- progressing from tethered, to remotely operated, to programmed and, finally, to rule-based autonomy. This vision includes the idea of the autonomous mine countermeasures brigade and also recognizes that components of the total system may range in size from bulldozers to automated lobsters. There will be variation in the cost of individual elements depending on size and complexity of the element.

## THE CHALLENGE

The Challenge is to solve the Mine Problem.

Apply emerging technologies to create a system or systems costing in the neighborhood of \$5,000 in production lots of 100,000. Members of this family of systems must be capable of being operated and maintained by military field units and/or by indigenous personnel in third world countries.

## **GOALS FOR THE 1996 SYMPOSIUM ON TECHNOLOGY AND THE MINE PROBLEM**

- \* Identify the technologies that can revolutionize approaches to dealing with the mine problem;
- \* Emphasize those technologies which contribute to the Navy-Marine Corps Mine Warfare Campaign Plan and its thrusts to support Operational Maneuver from the Sea and "organic" mine countermeasures;
- \* Match technologies and systems with the realities of Humanitarian De-Mining;
- \* Define the scope, magnitude, and future course of the national and international markets for mine clearance-related technologies and systems, including those based on commercial off-the-shelf (COTS) technology and products.

## **THE SYMPOSIUM SERIES ON TECHNOLOGY AND THE MINE PROBLEM**

In consonance with the objective of establishing the Naval Postgraduate School as a focal point for mine-related technology and analysis, it is the intent to hold a major technical Symposium at the Naval Postgraduate School at intervals of 18 months. The next Symposium will be the week of April 5, 1998, and will emphasize progress in the development of autonomous systems for mine countermeasures/countermine applications, C4I, including tactical decision aids and distributed modeling and simulation; and progress toward breaching -- overcoming obstacles in the surf zone, on the beach, and inland. Each of these major subject areas will be viewed from the standpoint of applications to military mine warfare on land and at sea and to humanitarian demining.

## **RECOGNITION OF SYMPOSIUM CHAIRS**

**General and Organizing Chair:** Professor Albert M. Bottoms, Ellis A. Johnson  
Chair of Mine Warfare, Naval Postgraduate School

**Honorary Chair:** RADM John D. Pearson, USN (Ret), former COMINEWARCOM

### **Session Chairs:**

- Session V:** Chair, RADM Charles F. Horne III, USN (Ret)  
Co-Chair, CDR John Peterson, USN (Ret)
- Session VI:** Chair, Dr. Don Brutzman, Naval Postgraduate School
- Session VII:** Chair, Walter E. Dence, Jr., Coastal Systems Station  
Co-Chair, Prof. Xavier Maruyama, Naval Postgraduate School
- Session VIII:** Chair, RADM John D. Pearson, USN (Ret)  
Co-Chair, CDR John Peterson, USN (Ret)
- Session X:** Chair, Prof. Fred Mokhtari, Norwich University  
Co-Chairs, Dr. Jackson E. Ramsey, James Madison University;  
and Assoc. Prof. Mitch Brown, Naval Postgraduate School

## RECOGNITION OF SYMPOSIUM CHAIRS (continued)

- Session XI:** Chair, Harry N. ("Hap") Hambric, Project Leader, Humanitarian Demining Program, U.S. Army Night Vision Electro-Optical Dir.  
Co-Chair, Assoc. Prof. Mitch Brown, Naval Postgraduate School
- Session XIII:** Chair, Prof. Anthony ("Tony") Healey, Naval Postgraduate School  
Co-Chair, Dr. Claude Brancart, C.S. Draper Laboratories
- Session XV:** Chair, Dr. David Heberlein, Program Mgr., Countermine, Fort Belvoir  
Co-Chair, COL Robert Greenwalt, USA, Director, Combat Developments, U.S. Army Engineer Center
- Session XVI:** Chair, Frank Uhlig, Naval War College  
Co-Chair, Assoc. Prof. Mitch Brown, Naval Postgraduate School
- Session XVII:** Chair, Ric Trotta, President, Trotta Associates  
Co-Chair, Dr. Kevin Owen, Naval Postgraduate School
- Session XIX:** Chair, RADM Richard D. Williams III, USN, PEO Mine Warfare  
Co-Chairs, George Pollitt, Technical Director, COMINEWARCOM, and Assoc. Prof. Don Walters, Naval Postgraduate School
- Session XX:** Chair, Lee Hunt, former Exec. Dir., Naval Studies Board, National Academy of Sciences  
Co-Chair, Asst. Prof. Knox Millsaps, Naval Postgraduate School
- Session XXI:** Chair, Dr. Ray Widmayer, Technical Director, Mine Countermeasures, Expeditionary Warfare Dir., Office of the Chief of Naval Operations  
Co-Chairs, Dennis Hiscock, Former Head, Mine Countermeasures, Royal Navy; Prof. Xavier Maruyama, Naval Postgraduate School
- Session XXII:** Chair, Prof. J.D. Nicoud, Laboratoire de Micro-Informatique  
Co-Chair, Assoc. Prof. Mitch Brown, Naval Postgraduate School
- Session XXIII:** Chair, Bill Baker, Clausen Power Blade, Inc.  
Co-Chair, Assoc. Prof. Robert Keolian, Naval Postgraduate School
- Session XXVI:** Chair, Dr. Frank L. Herr, Office of Naval Research  
Co-Chair, CAPT Wayne Hughes, USN (Ret), Naval Postgrad. School
- Session XXVII:** Chair, RADM Richard D. Williams, USN, PEO Mine Warfare  
Co-Chairs, George Pollitt, Technical Director, COMINEWARCOM; and Assoc. Prof. Don Walters, Naval Postgraduate School
- Session XXVIII:** Chair, Dr. Ray Widmayer, Technical Dir., Mine Countermeasures, Expeditionary Warfare Dir., Office of the Chief of Naval Operations  
Co-Chair, Dennis Hiscock, Former Head, Mine Countermeasures, Royal Navy; Prof. Xavier Maruyama, Naval Postgraduate School
- Session XXIX:** Chair, Prof. Anthony ("Tony") Healey, Naval Postgraduate School  
Co-Chair, Mr. Claude Brancart, C.S. Draper Laboratories
- Session XXX:** Chair, Dr. Norris Keeler, Kaman Diversified Technologies Corp., and former Director of Navy Technology, Naval Material Command  
Co-Chair, Dean and Prof. David Netzer, Naval Postgraduate School

## RECOGNITION OF TECHNICAL CONTRIBUTED PAPERS

The Mine Warfare Association established two prize categories for contributed technical papers, first presented at this 1996 Symposium on Technology and the Mine Problem. The CAPTAIN SIMON PETER FULLINWIDER Awards are for the best papers submitted by serving members of the Armed Forces. The First Prize in this category will carry an honorarium of \$500 and a Life Membership in the Mine Warfare Association. The Second and Third Prizes will, respectively, carry honoraria of \$250 and \$100. Each will also be accompanied by Life Membership in the Mine Warfare Association.

Captain Simon Peter Fullinwider (1871-1957) is deemed the Father of Mine Warfare by the U.S. Navy. Additional information about the contributions and energy of this remarkable man can be found in Dr. Greg Hartmann's book Weapons That Wait. This year the award was presented by RADM John D. Pearson, USN (Ret), Honorary Chair of the 1996 Symposium.

The Charles Rowzee Awards are for the best overall technical papers. The schedule of awards is the same as that for the Fullinwider Awards.

Charles Rowzee is the individual who applied years of experience in mine design to, in effect, enable the conversion of the large stocks of bombs into influence mines. This technical achievement led to the mining campaign against North Vietnam. That campaign, in turn, led to the return of the North Vietnamese to the negotiating table and to the subsequent release of Americans held captive by North Vietnam. The 1996 Rowzee Awards were presented by Mr. Charles Rowzee himself.

Dr. Ellis A. Johnson, Captain Simon Peter Fullinwider and Mr. Charles Rowzee are but three of the intellectual and operational giants to whom the United States owes its distinguished accomplishments in the fields of Mine Warfare. There are many others, both in and out of uniform. Perhaps a long-term project for the Mine Warfare community could be the creation of a Mine Warfare Hall of Fame.

The Award recipients for this Second Symposium on Technology and the Mine Problem are:

### **The 1996 Fullinwider Awards**

#### *First Prize*

Col. Robert Greenwalt, Jr., USA  
The Engineer Center, Ft. Leonard Wood, MO  
"Systems and Techniques for Countering Mines on Land"  
Col. Greenwalt's papers appear in Chapters 2 and 6

#### *Second Prize*

Lt. Col. Dennis Verzera, USMC  
Coastal Systems Station, Panama City, FL  
"A New Dimension in Amphibious Warfare"  
Lt. Col. Verzera's paper appears in Chapter 7

## **The 1996 Fullinwider Awards (continued)**

### *Third Prize*

Capt. Charles Young, USN

U.S. Navy Unmanned Undersea Vehicles Program Office

"Clandestine Mine Reconnaissance, Unmanned Undersea Vehicles"

Capt. Young's paper is in Chapter 5

### *Honorable Mention*

Col. Leroy Barnidge, USAF

Commander, 28th Bombardment Wing, Ellsworth AF Base

"U. S. Air Force Roles in Mine Warfare"

Col. Barnidge's paper is in Chapter 2

### *Group Awards*

Don Brutzman, Bryan Brauns, Paul Fleischman, Tony Lesperance,

Brian Roth and Forrest Young, Undersea Warfare Academic Group, NPS

"Evaluation of AUV Search Tactics for Rapid Minefield Traversal Using  
Analytic Simulation and a Virtual World"

Their paper is in Chapter 10

### *Group Awards*

Capt. Thomas R. Bernitt, USN, Commander, Explosive Ordnance Disposal  
Group One; CWO G. Mike Johnson, USN; Senior Chief Petty Officer

Chris A. Wynn, USN; and Lt. Eric Basu, USN

"Developments in the Very Shallow Water Mine Countermeasures Test  
Detachment Program"

Their paper is in Chapter 3

## **The 1996 Rowzee Awards**

### *First Prize*

Prof. Carl Schneider, Ph.D

Professor of Physics, U.S. Naval Academy

"Maxwell's Equations in Magnetic Signature Analysis"

Prof. Schneider's paper is in Chapter 9

### *Second Prize*

Major Colin King, Royal Army (Ret.)

Jane's Information Group

"Landmines and Humanitarian DeMining"

Major King's paper is in Chapter 3



## The 1996 Rowzee Awards (continued)

### *Third Prize*

Ms. Helen Greiner

ISR Robotics, Inc.

"Enabling Technologies for Swarm Coverage Approaches"

Ms. Greiner's paper is in Chapter 5

### *Honorable Mentions*

Prof. Joel Burdick, Ph.D.

Department of Mechanical Engineering

California Institute of Technology

"The Mechanics and Control of Robotic Locomotion"

Prof. Burdick's paper is in Chapter 9

Profs. Dale Lawrence, Renjeng Su, and Nouredine Kermiche

Center for Space Construction, University of Colorado

"Identification of Underwater Mines Via Acoustic Signature"

Prof. Su's paper is in Chapter 7

Mr. Dennis R. Hiscock, Royal Navy Scientific Service (Ret.)

"The Underwater Influence Fields of Target Ships and  
Systems Considerations"

Mr. Hiscock's paper is in Chapter 7

Prof. J. D. Nicoud, Ph.D.

Laboratoire de Micro-Informatique EPFL

Lausanne, Switzerland

"GPR and Metal Detector Portable Systems," "Post-conflict and Sustainable  
Humanitarian Demining," and "Cooperation in Europe for Humanitarian Demining"

Prof. Nicoud's papers are in Chapters 4 and 6

Mr. Jason Regnier

U.S. Army Night Vision and Electro-Optical Laboratory, Fort Belvoir, VA

"Tele-Operated Ordnance Disposal Systems for Humanitarian Demining"

Mr. Regnier's paper is in Chapter 4

John Richard Benedict, Jr.

The Johns Hopkins University, Applied Physics Laboratory (JHU/APL)

"Pervasive Technical Issues Related to Organic Mine Countermeasures (MCM)"

Mr. Benedict's paper is in Chapter 7

## Remarks of Mr. Charles A. Rowzee

To have an award bear my name is truly an honor and one of the highlights of my career -- especially an award in recognition of solving Mine Problems.

I have always considered myself fortunate to have contributed to solutions of mining problems. For me, this was a satisfying environment.

Before proceeding with the award presentations to the winning participants, let me say a few words about a weapon whose development is the reason why I'm here tonight. This weapon development was responsible for resolving a difficult sea problem -- the interdiction of roads and inland waterways. I am referring to the Destructor Weapon. This weapon system, consisting of an armful of components, converts the MK-80 series bomb into an underwater or land mine. Development from concept to deployment was accomplished in ten months, providing the Fleet with a safe, effective weapon at a cost of less than a pound of hamburger per pound of weapon.

If you think that this is the complete story, don't believe it. Now let me tell you the "rest of the story." Very simply, it's the Navy Laboratories, where individuals gain knowledge and experience to resolve challenging problems. This major weapon development -- concept to deployment in record time -- could have only been achieved through the years of experience I gained at the Navy Laboratory in White Oak, Maryland. So I say, "Thumbs Up" for the Navy and Defense Labs.



# WELCOMING REMARKS

**CAPT James M. Burin, USN**  
**Acting Superintendent**  
**Naval Postgraduate School**

Good morning. First of all, let me welcome you to the Naval Postgraduate School and Monterey. You have assembled an impressive group and you are meeting on a critical topic.

We have a lot of expertise and technology research here at NPS in mine warfare and related fields, so it's an ideal setting for your conference. While you're here, please feel free to talk to NPS staff and students and see what's going on here in these vital areas.

Since I have the opportunity, I would like to give you a brief on mine warfare. I have dropped some mines, both on land and at sea, and have some mine warfare experience. I have noticed that mine warfare, like nuclear weapons, used to be in war games. But no longer; no one wants to play because these weapons are a real 'show stopper.' Hopefully, you can fix that, so that mines are no longer show stoppers.

I am somewhat of a mine warfare cult figure. As Airwing Commander during Desert Storm, I went into Ash Shuwake Harbor in Kuwait three nights in a row looking for a ship called a Spasilac -- the Iraqi mine laying ship. On the first two trips, all I got was shot at a lot, but no ship. Yet persistence paid off. The third time it was not hidden well enough and I put two laser guided bombs into it. Now, *that's* a form of mine warfare!

And that leads to my final point. We need to think about mine warfare as a full spectrum problem, like we did about regimental backfire raids on Navy battle groups. Cruise missiles were another tough problem, like mines. So we tried to kill the archer, not the arrow. Then we went beyond air-to-air warfare, where we didn't just kill the arrow and the archer, but the quiver -- we used strike warfare. That should become a part of mine warfare, too. Get our strike warriors to find mines and kill them on the beach. We need to use our full spectrum warfare capabilities and technology to attack this difficult problem.

Again, welcome to the Naval Postgraduate School. I hope and trust you will have a valuable and productive conference.



# SPONSOR'S REMARKS

**RADM Paul G. Gaffney II, USN**  
Chief of Naval Research  
and  
**Dr. Fred E. Saalfeld**  
Deputy Chief of Naval Research, Technical Director



DEPARTMENT OF THE NAVY  
OFFICE OF NAVAL RESEARCH  
800 NORTH QUINCY STREET  
ARLINGTON, VA 22217-5660

IN REPLY REFER TO

5 November 1996

Dear Colleague:

The Office of Naval Research is proud to co-sponsor the 1996 Symposium on Technology and the Mine System, particularly as we celebrate 50 years of bringing science and technology to our Navy and Marine Corps and our Nation.

Welcome to what promises to be an exciting and rewarding week set in the historic and beautiful Monterey Peninsula. We have much to look forward to this week, and the tasks we hope to accomplish are ambitious:

- Identify technologies that can revolutionize approaches to dealing with the mine problem;
- Match technologies and systems with the realities of requirements for Humanitarian De-Mining;
- Define the scope, magnitude, and future course of the national and international markets for mine clearance-related technologies and systems, including those based on commercial, off-the-shelf products and technologies.

We encourage you to take an active role in the symposium -- participate, ask questions, and contribute your ideas. While you are at the symposium please visit the Office of Naval Research exhibit and pick up literature on some of our mine warfare efforts underway.

A handwritten signature in black ink, appearing to read "Paul G. Gaffney, II".

PAUL G. GAFFNEY, II  
Rear Admiral, USN  
Chief of Naval Research

A handwritten signature in black ink, appearing to read "Fred Saalfeld".

DR. FRED E. SAALFELD  
Deputy Chief of Naval Research  
Technical Director

# SPONSOR'S REMARKS

**Dr. David Skinner**  
Executive Director  
Coastal Systems Station, Dahlgren Division



DEPARTMENT OF THE NAVY  
COASTAL SYSTEMS STATION DAHLGREN DIVISION  
NAVAL SURFACE WARFARE CENTER  
6703 WEST HIGHWAY 98  
PANAMA CITY FL 32407-7001

Over the course of the past year we have made great strides in the improvement of Mine Warfare (MIW). The NSIA, ADPA, and now the Mine Warfare Association Conference have succeeded in educating and involving industry and academia to a high degree.

The Campaign Plan has provided a rallying point for the future direction of MIW and the Navy is taking notice. Readiness has been improved through the forward basing of MCM-1 ships and the development of contingency systems like RMS and Magic Lantern. Development programs have been streamlined and integration improved from 6.1 through 6.5. Management coordination and interaction have been improved throughout the MIW community through forums like the Flag Off-sites, the Acquisition Coordination Team, and MIW Technology Team.

The near-term goals have been accomplished. The mid-term is closing in and we are on track, but the MIW problem is far from solved. Our vision for the far-term must now be crystallized. The road ahead is sure to be as full of changes as the recent past. The Navy and the DOD are still evolving roles, missions, and functions. As we strive to keep pace with this evolution, several things are clear:

We must become fully integrated into the Naval consciousness;

We must continue to improve the Fleet's MIW capabilities;

We must stay ahead of our adversaries capabilities;

We must be cost effective; and

We must maintain a high level of awareness through the Navy.

How, then, do we solidify this far-term vision? We have already started down the path. We are establishing a common language for analytical discussion of MIW, and we are quantitatively baselining our near and mid-term capabilities with sophisticated modeling and simulation capabilities and Fleet exercises. We must then:

Determine our far-term needs;

Assess our expected capabilities against these needs to determine if we have shortfalls;

Develop approaches to fill these shortfalls;

Program, restructure, and adjust as required to provide the Naval MIW capabilities.

# INTRODUCTORY REMARKS

**Professor Albert M. Bottoms  
Symposium General Chair and  
President, Mine Warfare Association**

General Sheehan, General Howell, General Gill, Admiral Conley, Admiral Pearson, Admiral Gaffney, Dr. Saalfeld, distinguished guests and attendees:

It gives me great pleasure to open this second in the planned series of major technical Symposia at the Naval Postgraduate School on Technology and the Mine Problem. We plan to hold these every 18 months. The next one is scheduled for April 1998.

The seriousness and urgency of the mine problem can scarcely be overstated. Each person here has interest in and responsibility for some facet of the problem of mines -- operational, technical, programmatic, or policy. These concerns apply to sea mines, land mines, and to humanitarian demining. We note that technologies that relate to mines and mine countermeasures also apply to the efforts to remediate areas contaminated with UXOs or hazardous materials. Mine technology and countermine processes may also be applicable in counter-terrorism.

This week Monterey is the mine capital of the world. We at the Naval Postgraduate School have a vision as to how the emergent technologies about which you will hear eventually will be combined into affordable, autonomous systems that can deal effectively and in a timely manner with mines, booby traps and obstacles. This is precisely what we mean when we say that our objective is "to change the world."

The military art of mine countermeasures is supported by a "System of Systems" -- a tool box of hardware and approaches. We challenge the systems people to think about how and when the emergent technologies can be brought together into systems approaches. Systems people are a breed apart. They see combinations. They intuitively understand mission needs and operational constraints. This Symposium should provide an opportunity for the systems people and the technologists to form networks.

Systems people, along with programmatic sponsors, also think in terms of milestones and time lines. You will hear about the ACTD candidate technologies. The ACTD field exercises in FY'97 and FY '98 are the next official milestone events. But much of what you will hear falls on either side of these ACTD milestones.

Some ideas, such as bulldozers and rakes, may be described as "low tech," but, as Mr. Bill Baker points out, also "high technique." Other ideas involve computational power and



flexibility only now coming within grasp. We urge you to help us identify these post-ACTD milestones. Help us to define for the mine warfare System of Systems the initiatives that correspond to “planning wedges” and “block upgrades” for platform acquisitions.

Now, I ask that we pause in our anticipation of the program over the next four days to honor the memory of Admiral “Mike” Boorda, USN, former Chief of Naval Operations, who personally encouraged our efforts and our vision for mine countermeasures systems at NPS. He wrote that he concurred that the vision is within grasp.

I now call upon the NPS Command Chaplain, Chaplain John Wright, to give the invocation for the Symposium.

## CHAPTER 7: TECHNOLOGIES FOR COUNTERING MINES AT SEA

In this Chapter are the papers that most closely address the problem of countering mines at sea. Note that the technologies and systems discussed herein may also be applicable to the related military problem of countering mines on land, and to Humanitarian Demining.

Military scenarios for sea mine countermeasures have some differences from military land countermine scenarios. For one, in the pre-assault phase of an amphibious forcible entry, there is a premium on the capability to conduct clandestine or covert reconnaissance of the area.

Assault mine countermeasures is not the only sea mine countermeasures scenario. There is also the problem of securing sea lanes of communication by being able to guarantee port egress and ingress, and the safe transit of choke points, mineable channels, etc. As in the assault case, there is often an inexorable timeline. The adroit use of the minefield introduces delays, spoils enemy timelines, introduces psychological uncertainty, and in general introduces damaging unknowns into the overall calculus of combat.

The physical environment dominates mine countermeasures at sea. The transitions from deep water, to shallow water, to very shallow water, to the surf zone, and, finally, to the beach are present in varying degrees in almost every naval mine countermeasures operation. The technological approaches and candidate systems must respond to those environments. As with land mine countermeasures, sensors are major components of the enabling technologies.

Many cutting-edge technologies and systems are scheduled for demonstration under the ACTD program over the next two years. The 1998 Symposium on Technology and the Mine Problem will provide an opportunity for discussion of the results of those demonstrations. In the Call for Papers for the April 1998 Symposium, we will include a call for evaluation techniques based upon modeling and simulation.



# **The Underwater Influence Fields of Target Ships: Some Mine Sensor System Considerations and the Strengths and Weaknesses of Influence Mine Sweeping**

Mr. Dennis R. Hiscock

Former Head of Mine Countermeasures, Royal Navy, U.K.

The purpose of this paper is threefold:-

- (a) To review the origin and nature of target influence fields capable of being exploited by a sea mine designer.
- (b) To consider some relevant minesweeping aspects of mine sensor system design.
- (c) To address the strengths and weaknesses of influence minesweeping.

It should be stressed that the views expressed are those of the author and in no way should be associated with or attributed to any governmental or commercial organisation.

## INFLUENCE FIELDS

The main influence fields utilised by a sea mine designer in posing a threat to a target are:

- \* Magnetic
- \* Acoustic - including seismic
- \* Pressure

To a lesser extent the following are also exploited:

- \* Underwater Electric Potential (UEP)
- \* Alternating Electric (AE)
- \* Alternating Magnetic (AM)

The latter two are collectively known as the ELFE phenomenon.

### Copyright

The copyright of this paper rests with the author. Permission to copy the contents either in part or in whole should be sought from him as required.

## MAGNETIC

The magnetic influence field of a target vessel comprises two main components

- 1) An induced field due to the Earth's magnetic field interacting with the targets ferro-magnetic content.
- 2) A permanent field due to the targets remanent magnetization.

Whereas the strength and direction of the induced field varies according to the target's latitude and heading, the permanent field is acquired during construction and through life operating environment. Other influence field sources are due to eddy currents arising from target roll and pitch and stray fields generated by electrical rotating equipment. These are of particular relevance to low magnetic influence field targets such as MCMV's.

The permanent and induced fields of the target can be considered to be equivalent to a volumetric distribution of three axis magnetic dipoles and, if their strengths were known, classical techniques for field computation could be applied. However, the latter is impractical and the current approach, which has evolved over many years, is to magnetically range target vessels and apply mathematical techniques to deduce the various field elements. Field strengths in other than the range measurement environment can then be determined. It appears that, even for low influence field targets, such as GRP MCMV's in depths as shallow as nine metres, a linear distribution of magnetic dipoles suffices to characterise the induced and permanent fields. This is even more so for steel targets where vertical and horizontal fields from the ferromagnetic content predominate, and is of significance when considering influence field sweep simulation systems. Field levels from this magnetic content can range from tens of nano-tesla for a degaussed vessel to thousands of nano-tesla for an undegaussed steel vessel.

As the fields are essentially magnetic dipole in origin they fall off rapidly with range. Indeed, at extreme ranges where the ship is seen as a single dipole, inversely as the cube of the range.

## ACOUSTIC

Acoustically, power driven targets radiate significant levels of underwater energy. This emanates from propulsion machinery, hull vibrations, auxiliary machinery and propeller beat and cavitation. Other hydrodynamic flow noise sources also radiate energy. The resultant acoustic pressure fields are extremely difficult to predict and can be quite variable due to changes in the propagation environment particularly in shallow water. They are broad band typically ranging from 1 Hz to 100 KHz with superimposed line structure at low frequencies.

The very wide range of acoustic sources makes it extremely difficult to mathematically represent the ship by classical monopole, dipole or multipole distributions and resort has to be made to at sea measurements to quantify the field characteristics.

Levels of narrow band spectral lines at low frequencies are typically between about 135 and 150 dB relative to one micropascal at one metre. Spectral levels are higher being approximately constant up to about 1 KHz falling off thereafter with increasing frequency.

In deep water sound pressure levels tend to fall off inversely as the square of the range and therefore remain above background levels at ranges further than the magnetic or hydrodynamic pressure influences. They are target speed dependent.

In shallow water the nature of the propagation changes from spherical to cylindrical spreading with an even lower rate of fall off of amplitude with range.

In the shallow water the acoustic energy radiated by targets excites the sea-bed giving rise to seismic effects. The nature of these depends critically on the acoustic characteristics of the sea-bed.

### PRESSURE

The sea-bed hydrodynamic pressure field of a ship, submarine or hovercraft target is seen as a change in ambient pressure comprising two components.

- (a) a displacement field dominant at low percentages of the critical wave speed  $(g \times \text{depth})^{1/2}$  and
- (b) a wavefield comprising transverse and divergent waves below and divergent waves only above, the critical speed.

The pressure fields can be accurately calculated in zero background swell conditions by replacing the target by a linear distribution of hydrodynamic doublets whose strengths is proportional to the ships curve of underwater areas. In the case of a hovercraft its field is equivalent to a surface ship of equivalent displacement.

Target submergence affects both the displacement and wavefield components, the latter attenuating with depth of submergence whilst the former changes in character with little change in maximum amplitudes. However significant increases in rates of change, particularly near the bow and stern, occur as submerged depth increases.

The displacement component of the field is in essence collocated with the target. It is characterised by an increase in pressure as the bow approaches a point on the sea-bed followed by a decrease in pressure just aft of the bow to just forward of the stern returning to a pressure increase as the target passes. The duration of negative pressure under the bed is approximately equal to the prismatic length (prismatic coefficient x waterline length) divided by the forward speed. Amplitudes are approximately proportional to the square of the speed and decrease with increasing water depth, very approximately as (depth)<sup>1.5</sup>. They fall off more rapidly with distance beam and range in amplitude from a few millimetres to many centimetres of water head.

Background swell with interfering wavelengths of tens to hundreds of metres breaks up the calm water influence field signature. This is of far greater significance than the corresponding background magnetic and acoustic noise fields. For swell coming from directions directly ahead or astern a simple addition of the respective fields suffices to determine the resultant. However, for swell direction from the beam a more complex interaction is involved.

#### UNDERWATER ELECTRIC POTENTIAL (UEP)

UEP is an electrical influence field arising from the direct corrosion currents which flow around the hull of a target emanating from the use of dissimilar metals in an electrolytic medium. It can also be due to the Current Cathodic Protection System which may, of course, be switched off in a wartime situation. To a first approximation the target can be considered to be equivalent to an electric dipole of strength typically in the tens to hundreds of ampere-metres range. The electric dipole will have an associated magnetic effect.

#### ALTERNATING ELECTRIC (AE)

The alternating electric influence field arises from the modulation of the corrosion currents producing the UEP phenomenon, and the emissions from domestic and the numerous support systems. A wide frequency band is broadcast from the target but the important range is 0.5 Hz to 1 KHz. The effective dipole strengths again vary from tens to hundreds of ampere-metres.

### ALTERNATING MAGNETIC (AM)

The electrical fields from the UEP phenomena have an associated magnetic field effect. In addition, the electrical machinery and equipment facilities on board a target vessel, in particular the electric power distribution system, radiate magnetic fields. Frequencies are typically in the range of 0.5 Hz to 1 KHz and dipole strengths may again range from tens to hundreds of ampere-metres.

This electro magnetic influence field can be extremely important in the case of GRP or wooden, MCMV's since their hulls will not attenuate the magnetic emissions.

The UEP, AE and AM sea-bed influence fields depend on the conductivity profiles of both the sea-water and sea-bed. Given appropriate models for these then classical techniques can be used to quantify their propagation characteristics.

### SUMMARY

In summary, pressure influence fields can be calculated: magnetic influence fields need to be measured in one set of conditions of locality, depth and distance abeam but then can be modelled to calculate fields in other localities depths and distances abeam: acoustic influence fields need to be measured: underwater electric potential and alternating electric and magnetic influence fields need to be measured in known conductivity environments and then modelled to calculate fields in other conductivity environments.



## MINE SENSOR SYSTEM DESIGN ASPECTS

This section of the paper is not intended to be an in depth analysis of mine sensor system design: rather it is a limited review of some aspects of their concept and implementation which have relevance to their countermeasure. A more comprehensive analysis would inevitably lead to a higher security classification.

Ground influence mine sensor systems utilising magnetic, acoustic, pressure or UEP fields can and have been used singly. Combination mines requiring the presence of two or more influences suitably colocated increase the sweeping problem: however another reason for their use is to prevent false actuations due to background noise.

Moored influence mine sensor systems are more likely to utilise acoustic magnetic, UEP and ELFE phenomena due to motion noise affecting the pressure influence.

Seismic sensor systems, by nature of the propagation phenomena, will be limited to a target alert function only.

Magnetic mine sensor systems employ either a search coil or a magnetometer to provide the necessary input into the target detection mechanism. Search coils sense the magnetic field changes, in one direction, caused by a moving target, namely along their central axis and are therefore orientation dependent. This is of significance in the determination of sweeping widths which will vary according to the mine sensor orientation. Magnetometers however can be used in multi axis configuration and hence, if the mine designer so chooses, measure the total magnetic field disturbance thus making swept path assessment more predictable.

In either case target data input into the firing mechanism can be processed in a number of ways designed to optimise the firing point to achieve the required damage and to maximise countermeasure resistance. For example, logic could require sweep signals to be target-like and minimise false actuations due to environmental effects. The need for emulation sweeping can thus arise. Furthermore the advent of modern technology does give rise to the possibility of lateral range assessment so enabling the mine to be actuated only within the target damage contour.

Passive acoustic mine firing mechanisms have employed either vibration sensors or hydrophones to convert the applied influence fields into electrical signals for analysis and processing. To maximise countermeasures resistance, acoustic energies which either build up too slowly or develop too quickly are rejected. In general, acoustic sensor systems respond only to energies within given frequency bands and which increase in intensity at prescribed rates of change. Seismic sensor systems essentially use accelerometers.

Active acoustic mine sensor systems use upward looking echo sounders to achieve the required firing point within the targets damage contour. Combined active passive acoustic sensor systems can also be utilised.

Pressure mine sensors employ classical techniques for measuring the change in ambient pressure and mine types include:-

- (a) Simple conventional in which a preset reduction change in ambient pressure is required to be maintained for at least a given time.
- (b) Integrating in which the integral of the square root of the negative pressure is required to be exceeded for a given time, so reducing sensitivity to target speed changes.
- (c) Pseudo-integrating in which a number of simple conventional mine settings are used in a single mine - with only one set needing to be satisfied for actuation - to reduce the sensitivity to target speed.

The mine designer has to take into account the effect of background swell - more than one design is known to have had an unacceptable performance in terms of false actuations - and consideration has been given to the use of filter techniques, particularly for large targets, exploiting the considerable difference between the fundamental frequency of the target field and the period of the interfering swell.

In general, however, because of the uncertain nature of the swell background the mine designer is not likely to use the pressure influence alone; it most probably would be incorporated in a magnetic, or acoustic-magnetic unit. The primary function therein would be as an anti-sweeping device.

UEP and alternating electric systems measure potential differences between electrodes and associated alternating magnetic fields are sensed using magnetometers.

In summary, mine sensor system design capabilities lead to generic sweeping requirements reflecting the need to produce in the vicinity of the mine spatial and temporal simulations of the target vessel influence fields. The simulation should be such that the mine designer cannot exploit differences between the influence fields of the target vessel and sweep. Nevertheless, the mine has to pose an appropriate level of threat to a target if the mining policy is to be effective. This could entail utilising influence field signatures at the required lateral damage range rather than those directly under the keel. Since the fine structure of the influence fields decreases as the lateral range increases, this could ease the sweeping problem.

## THE STRENGTH AND WEAKNESSES OF INFLUENCE MINE SWEEPING

This section of the paper initially summarises types of influence mine sweeping systems before addressing perceived strengths and weaknesses both in a general and specific sense.

### MAGNETIC

Magnetic minesweeping systems aim to produce simulations of the ships magnetic field in the vicinity of the mine. The majority of in service sweeps involve the generation of a very large electrical current which is transmitted through insulated cables which are towed astern of the deploying platform. In open loop sweeps, the current passes from one cable leg via an electrode into the sea returning to the generator via an electrode on the other cable leg.. In closed loop systems the two cable legs are effectively joined to form a loop. The current through the two cables is modulated to try and simulate the shape of a ships magnetic signature.

In recent years both towing highly magnetised devices or variable moment magnets to likewise simulate ships magnetic fields have been successfully demonstrated. Electromagnetic solenoids have also been used, particularly in remote systems.

Open loop system performance is sensitive to the conductivity of the sea water and sea-bed and an associated monitoring system is desirable if tactics are to be optimised. Environmental prediction is feasible but not very reliable, particularly in shallow water.

### ACOUSTIC

There are three main generic types of acoustic minesweeping system:-

- a) noise makers including those in the form of explosive devices, hammer boxes, towed pipes (rattle bars), pneumatic jack hammers, motor driven vibrating diaphragms, spark discharges, pulsed cavitating venturi tubes.
- b) underwater loud speakers both electrodynamic and hydraulic driven by electronic oscillators and amplifiers.
- c) Magneto strictive/Piezoelectric active broad band transducers.

The last two types can be externally programmed to simulate various acoustic signature characteristics. However, to adequately simulate a target acoustic signature more than one type of generic sweep is likely to be required.

The performance of acoustic sweeps is environmentally sensitive due to changing propagation conditions in the water column and sea-bed. Monitoring of sweep performance is necessary in ship deployed systems to ensure that the risk to the deploying platform is not increased. Whilst prediction of sweep performance based on knowledge of the relevant environmental parameters is feasible, this approach is not very reliable particularly in shallow water.

Seismic sweeps are essentially very low frequency acoustic generators employing either electrodynamic or electro hydraulic noise makers - the latter including air guns.

### PRESSURE

Pressure minesweeping systems investigated have included the following:-

- a) Explosive resistant displacement sweeps
- b) Wavemaking devices
- c) Hydrofoil systems
- d) Vortex generators
- e) Pseudo - displacement devices
- f) Guinea Pig Ships

Of these the most effective, taking into account also the need to provide associated electric magnetic and acoustic fields, is the guinea pig ship. However, the displacement of this ship has to be at least commensurate with the size of the target vessel to be protected and even greater if operationally desirable swept paths are to be achieved.

### UEP/ELFE

UEP and alternating electric and magnetic minesweeping systems are relatively simple requiring the implementation of current dipoles, modulated as necessary, to simulate the required characteristics.

## STRENGTHS AND WEAKNESSES

The strengths of influence minesweeping systems in general include:-

- a) The presence of a threat is confirmed once a mine has been swept
- B0 The threat is seen to be removed
- c) Buried mines can be countered
- d) The interface with the combat systems centre is relatively simple
- e) There is potentially a high single pass rate of coverage
- f) The systems are relatively easy to maintain and operate
- g) Their availability restricts the options open to the mine designer

In contrast their weaknesses include, not in any order of priority:-

- a) Clearance rate is sensitive to ship counts
- b) Non-ship like fields can be exploited by the mine designer
- c) Associated with b) not all influences can be practically simulated.
- d) Multi influence sweeping requirements exacerbate the handling and deployment problems.
- e) Performances can be environmentally dependent
- f) Sweeps need to be explosion resistant
- g) The towing platform's manoeuvrability is restricted
- h) The deployment platform has to pass over the minefield
- i) Organic systems are limited by deployment system space, weight and power availability
- j) Knowledge of threat characteristics is highly desirable to optimise performance and tactics
- k) When the mine characteristics are unknown a policy of target protection rather than one of sweeping specific mines has to be implemented
- l) Operations are tedious and can be time consuming even with potentially high coverage rates

## Specific Weaknesses

### Magnetic

- a) Loop systems require high power and signatures are difficult to make ship-like.
- b) Open loop system performance is environmentally sensitive and field monitoring is desirable to obtain knowledge and effectively use, the influence fields created.
- c) Solenoid systems require high power and need to be used in tandem to simulate target fields effectively. However they are the only practical means of simulating the three dimensional influence field characteristics of targets.
- d) Permanent magnets are heavy and operationally inflexible.
- e) Variable moment magnets are impractically heavy if there is a requirement to simulate undegaussed fields of large targets.
- f) Tandem systems, if towed, have to be deployed well astern to maintain safety of towing platform.

### Acoustic

- a) More than one system needs to be deployed to cover the frequency band of interest.
- b) Performance prediction and monitoring especially in shallow water, is difficult and unreliable at low frequencies.
- c) The towing platform can be put at risk if acoustic sweep outputs are not appropriately monitored and controlled.
- d) They are invariably negatively buoyant so additional buoyancy devices maybe required to ensure stable depth of tow.
- e) Their explosion resistance is limited.

### Pressure

- a) The sweep displacement must be at least commensurate with target size of the target to be protected.
- b) The performance is affected by natural background swell.
- c) Explosion resistance is limited.

UEP/ELFE

- a) The performance is environmentally sensitive - and appropriate monitoring and control is necessary.

SUMMARY

In summary this paper has reviewed the origins and nature of influence fields which may be exploited by a mine designer: some aspects of mine design relevant to the problem of influence minesweeping and finally the strengths and weaknesses of systems designed as countermeasures.

It is not intended to be an in depth treatment of all these topics: nor could it be in an unclassified publication. Finally I would again stress that the views expressed herein are those of the author alone.

# Pervasive Technical Issues Related to Organic Mine Countermeasures (MCM)

John Richard Benedict, Jr.  
The Johns Hopkins University  
Applied Physics Laboratory (JHU/APL)  
Johns Hopkins Road  
Laurel, MD 20723-6099 USA

**Abstract** - JHU/APL has recently been involved in a series of operational effectiveness analysis studies related to minefield reconnaissance and/or mine detection and avoidance. As a result, various onboard and offboard system alternatives and their associated tactics have been assessed at the sensor, unit, and mission levels to establish potential contributions to organic mine countermeasure efforts. In other words, the ability of these systems/tactics to enhance the counter-mine capability of forward deployed forces (submarines or multi-purpose surface combatants) in the absence of dedicated MCM assets was evaluated. By the conduct of these studies, a unique perspective has been gained on the pervasive technical issues that will likely determine the degree of success of future organic MCM operations. Some of these issues include:

- a. The development of reliable computer aided detection algorithms for onboard search sonars to enhance the ability to discriminate clutter (and thus avoid a sea full of clutter objects).
- b. The ability of search sonars to exploit multipath in key littoral environments, i.e., the ability to maintain target echo coherence after multiple boundary interactions.
- c. The development of reliable computer aided detection/classification/identification (CAD/CAC/CAI) techniques for autonomous (untethered) offboard vehicles, both to manage the clutter and to make correct calls on actual mines.
- d. The development of safe, high density energy sources, e.g., for the employment of unmanned undersea vehicles (UUVs) on submarines.
- e. The ability to achieve high mission reliability with offboard vehicles conducting long endurance mine reconnaissance operations.
- f. The ability to reduce/control signatures on offboard vehicles to minimize their vulnerability to mines during reconnaissance missions.
- g. The development of precise navigation techniques for offboard vehicles during long endurance reconnaissance missions, i.e., consistent with overall mission accomplishment.

Each of these technical issues will be addressed in terms of the insights gained from associated operational effectiveness analyses; for example, how good is good enough in terms of these technical developments (sensor performance, energy sources, reliability, signatures, accuracies) to support various tactics and mission objectives?

## I. INTRODUCTION

In a 1995 white paper entitled "Mine Countermeasures - An Integral Part of Our Strategy and Our Forces", Chief of Naval Operations (CNO) Boorda stated the following:

"For the long term, we will focus on innovative technologies, systems, and techniques that will ensure future organic MCM capabilities

will become available...the Navy's dedicated MCM forces will augment and complement the organic capabilities resident throughout the operating forces..." [1]

This CNO perspective represents a sea change in MCM and refers to the current emphasis on upgrading the organic "capability that is carried in forward deployed forces to allow early MCM operations" [2]. There is increased focus on integrating advanced MCM systems



into submarines, surface combatants, and ship-based helicopters such as the SH-60. Dedicated MCM forces such as current airborne and surface units will still play a key role as shown in Figure 1 from the April 1996 U.S. Naval Warfare Plan, but it will not be an exclusive role [3]. In fact, the issue of how to best employ organic and dedicated MCM forces in future contingencies is currently under study. The diverse systems presently under development within each of the components of the MCM pyramid are shown in Table 1.

The required counter-mine capability categories, based on a review of relevant Mission Need Statements (MNS) and Operational Requirement Documents (ORDs), are summarized in Table 2. Of the six capability areas shown, three relate primarily to Dedicated MCM Forces - clearance of the sea mine threat, mine/obstacle clearance of the landing area, and accurate lane marking of the landing area. Three other areas identified in Table 2 are the principal perceived capabilities for Organic MCM Forces - rapid reconnaissance and assessment of the mine threat (possibly clandestine), organic mine detection and avoidance, and accurate/timely clandestine reconnaissance of mines and obstacles as part of shallow water MCM (SWMCM) operations in support of amphibious assaults. The latter includes the beach, surf zone (SZ,  $\leq 10'$  of water), very shallow water regions (VSW, 10-40'), and shallow water areas (SW, 40-200').

There is considerable functional overlap between Dedicated MCM and Organic MCM assets. Organic MCM forces may ultimately be given some limited mine clearance capabilities. Dedicated MCM forces as part of their minehunting/neutralization or minesweeping efforts will often do mine reconnaissance, where mine reconnaissance is defined as an "MCM operation that encompasses some or all of the following:

- (1) Detection - process of determining that an object is present
- (2) Classification - process of determining if the object that has been detected is mine-like or nonmine-like
- (3) Identification - process of determining if a mine-like object is actually a mine" [2].

Figure 2 presents a summary of the assets, key functions, and key MCM roles for each of the following: the Dedicated MCM force (mostly non-clandestine), the Organic MCM force (clandestine portion), and the Organic MCM force (non-clandestine portion). The Dedicated MCM assets include Air MCM (i.e., MH-53E), surface MCM (MCM-1 and MHC-51 classes), SWMCM (e.g., U.S. Marine Corps forces such as MCAC), Explosive Ordnance Disposal (EOD), Naval Special Warfare (NSW), and marine mammals. These assets are either overt (Air MCM, Surface MCM, SWMCM, EOD) or clandestine but slow in terms of minehunting/neutralization (NSW, marine mammals). Their main roles relate to SWMCM breaching operations, clearance of sea lines of communication (SLOCs) and operating areas (OPAREAs) in less contested regions, and clearance of U.S./Allied ports.

For the Organic MCM forces the distinction between clandestine and non-clandestine assets is even more essential to understanding which assets are intended for what MCM roles. Reference 2 states that "a clandestine operation conceals the intent...to prevent enemy exploitation." Organic MCM assets capable of clandestine reconnaissance include nuclear attack submarines (SSNs) employing unmanned undersea vehicles (UUVs), national systems such as Radiant Clear, and airborne systems such as the Cobra unmanned air vehicle (UAV). These clandestine systems are intended to conduct reconnaissance in support of amphibious assaults (inside the radar horizon of adversary coastal defenses), in highly contested SLOCs/OPAREAs, and for SSN missions in potentially minable waters.

Organic MCM assets capable of non-clandestine reconnaissance include surface combatants employing semi-submersibles and helicopters. These platforms and their associated sensors are intended to conduct reconnaissance in support of the amphibious objective area or AOA (but beyond the adversary surveillance horizon and coastal defenses), in less contested SLOCs/OPAREAs, and for surface combatant missions in potentially minable waters. Table 3 further contrasts the differences in clandestine versus non-clandestine mine reconnaissance operations in terms of the key platforms, offboard vehicles, and associated communications

between the offboard vehicles and their host platforms.

Table 4 presents a summary of the recent studies that have been conducted related to Organic MCM reconnaissance and/or avoidance. Most of these studies have been Cost and Operational Effectiveness Analyses (COEAs) for specific platforms (New SSN, 21st Century Surface Combatant), offboard vehicles (Submarine Offboard Mine Search Systems, Long Term Mine Reconnaissance System, Remote Minehunting System) or sensor programs (BSY-1 High Frequency Upgrade, Advanced Laser Mine Detection System). Two studies will be emphasized in the material that follows, i.e., the LMRS COEA and the Future Fleet Combatant Organic Mine Avoidance and Reconnaissance (FFCOMAR) Study. The LMRS COEA will highlight a number of technical issues associated with offboard vehicles performing clandestine mine reconnaissance missions. The FFCOMAR study had the widest scope of the studies shown and provides key insights on the advantages and disadvantages for various Organic MCM approaches, including onboard versus offboard system trade-offs.

## II. FFCOMAR STUDY INSIGHTS

The FFCOMAR study was conducted for the Program Executive Office for Undersea Warfare, PEO (USW), and included a COEA-like Oversight Board that had representatives from PEO Mine Warfare (MIW) and various OPNAV offices [4]. JHU/APL led the associated analysis effort, but received significant support from other organizations such as the Naval Surface Warfare Center/Coastal Systems Station (NSWC/CSS) and the Naval Undersea Warfare Center (NUWC).

Table 5 depicts the scope of the MCM system alternatives that were analyzed. The options included various onboard sonar systems for real-time mine detection and avoidance, offboard vehicles and helicopters for mine reconnaissance, and ship signature reduction techniques to reduce the likelihood of mine actuation.

### A. Onboard Sonars

Current SQS-53 "Kingfisher" systems are designed to detect moored mines near the

surface but not mines near or on the bottom. Future Kingfisher upgrades should focus on resolving key clutter management issues (e.g., discriminating better between actual mines and natural clutter). An Advanced Mine Detection System (AMDS) "Chin Array" equivalent capability (to that being designed for the NSSN program) on surface ships would greatly enhance mine detection capability, particularly against difficult bottom mines. However, AMDS could face similar clutter issues. Furthermore, in shallow water locales featuring significant multipath effects, a critical issue for all onboard sonar alternatives will be the extent that target echo returns will remain coherent (and exploitable). If multipath is not exploitable due to environmental conditions (e.g., sea state, bottom type), then onboard sonar detection ranges will likely be too limited to support timely ship avoidance maneuvers under many shallow water operating conditions. Nevertheless, ship onboard sonars provide two potential advantages over offboard system solutions - they offer both high availability and an ability to support modest ship speeds of advance (SOAs).

Figure 3 depicts the difficulty of conducting real-time mine detection and avoidance operations in even moderate clutter environments such as the 16 clutter objects per square nautical mile case shown. The maneuvering ship would only have a partial, evolving view of the potential mine objects and could easily find itself in a "cul-de-sac" dilemma. In a situation such as the one shown, the ship would likely do much maneuvering against clutter (e.g., non-mine bottom objects); this could actually prove counterproductive to safe transit if the onboard sonar is not particularly capable of detecting bottom mines.

### B. Ship Signature Reduction

Similar to onboard sonars, ship signature reduction efforts would offer high availability and would be compatible with modest ship speeds of advance. Unlike most minehunting systems, however, they would not be degraded by high sea states. For surface combatants, advanced degaussing systems appear more robust than advanced acoustic signature reduction systems, e.g., in terms of providing safe water depths for which a ship can operate

against bottom mines under various conditions. Advanced systems of these types would primarily be applicable to new construction ships. However, for upgrades to existing ships even modest signature reduction measures could prove cost-effective (perhaps not robust against the full threat spectrum, but still effective against specific mine threats of interest for very little investment cost). Ship signature reduction efforts should be viewed as a key element in self-protection against mines but are unlikely to prove sufficient for future surface combatants. For example, they are not applicable to highly prevalent moored contact mines, and there are practical (affordability) limits on ship quieting effectiveness against modern mines either deployed near the surface or placed on the bottom in shallow water environments.

### C. Helicopter Systems

The helicopter systems analyzed were not robust for the mine threats and environments examined. Yet, of all the MCM systems evaluated they were potentially the most compatible with modest to high ship speeds of advance. They also provided an independent opportunity from onboard systems and were not subject to the same time-criticality for effective ship maneuvers as were onboard systems. The helicopter systems were not sufficient, however, because either they covered only a portion of the water column (laser systems) or their performance was modest at best against various mine types (dipping sonar system). The helicopter sensors would also face similar clutter issues as the onboard systems. In addition, based on potential mission conflicts and flight restrictions, helicopter availability for MCM operations could prove situation specific. Both of the helicopter upgrades (dipping sonar and laser related), nevertheless, appear cost effective, despite their lack of robustness. The ALFS upgrade involves a software adaptation and appears very affordable. The airborne laser system involves more investment but, if properly designed, should prove to be a cost-effective solution against moored contact mines.

### D. Offboard Vehicles (e.g., UUVs)

Of all the MCM system categories evaluated, offboard vehicles equipped with search and/or classification sonars proved to be the most

robust in terms of covering all the mine types and water depths of interest. Offboard vehicles conducting reconnaissance well in advance of the ship were able to detect a high percentage of mines by adapting the recon track separation to match the particular sonar performance achievable in a given environment. However, recon efforts were time-consuming, particularly if employing limited range classification sonars or search sonars in adverse multipath environments, and thus were incompatible with even modest ship speeds of advance. For the foreseeable future, offboard vehicles will not be sufficient, because they are likely to be procured in relatively small numbers, i.e., not every surface combatant will have one for its own self-protection. Key issues for offboard vehicles include emphasis on search versus classification sonars (related to trade-offs between high area coverage rates and low clutter levels/densities) and the need for either advanced pattern recognition techniques or ID sensors (optical) to establish the presence of mines. In terms of vehicle trade-offs, unmanned undersea vehicles (UUVs) offer low signatures and covertness but may have limited endurance and connectivity to the ship. Semi-submersibles (e.g., similar to the Dolphin vehicle) offer potential for increased endurance and connectivity but would have less stealth/covertness than UUVs (possibly making them more vulnerable to mines or other enemy counteractions and also less compatible with operational security for some missions).

Figure 4 is an example of the detected objects during a mine reconnaissance mission conducted by a UUV employing ahead looking search sonars. It illustrates several things. First, much information is possible from search only operations (without the benefit of classification sonars) that are compatible with high area coverage rates. Three separate minefields are evident amidst the apparent clutter objects; this is possible because these are dense anti-invasion minefields similar to those laid off Kuwait during Desert Storm. The second insight is that a porous line of rocket-propelled mines in the upper right portion of the same figure is not obvious even to a studious observer. This reinforces the need for one of two solution paths. One approach would be to select one/few preliminary transit/assault lanes and to revisit those areas with a UUV employing classification sonars to "declutter" the previously detected

objects, i.e., reject the objects that no longer appear mine-like. A second approach is to develop sophisticated "discriminants" into the computer-aided detection (CAD) algorithms to evaluate and categorize the objects detected by the search sonar. If the multi-dimensional characterizations of several mines are very similar and they form an unnatural pattern (such as a line), then it would be easy to discriminate those objects from the random clutter objects in the background.

#### *E. Summary*

From the FFCOMAR study results, it was apparent that no "single silver bullet" could be found; in fact, the study results validated the need for a complementary blend of Organic MCM systems for the self-protection of future surface combatants. Otherwise, mines could prove a "show-stopper" for ships attempting to accomplish critical missions early in a conflict (prior to extensive mine clearance operations by Dedicated MCM forces). The Aegis destroyer assigned to a Theater Ballistic Missile Defense (TBMD) patrol outside a key port on the first day of a Major Regional Contingency (MRC) must rely on its own MCM capability to transit safely to and operate within its TBMD patrol area. Some combination of onboard sonars, ship signature reduction and control, offboard vehicles, and helicopter systems will be needed to mitigate the risk from mines. The predominant MCM technique will depend on the operational circumstances, availability of offboard vehicles, environmental conditions (sea state, bottom type, water depth), and mine types of concern.

### III. LMRS COEA INSIGHTS

The Long-Term Mine Reconnaissance System (LMRS) is an advanced UUV that is deployed from submarines and capable of conducting clandestine mine reconnaissance. A COEA was conducted to establish the performance and cost levels that were feasible (within the bounds of potential technologies) and desirable, i.e., both good enough to accomplish the needed missions and affordable (within perceived budget constraints). The intent of the COEA was not to select the specific technology solutions because that will be determined by industry as part of a competitive acquisition

process. The COEA was intended to clarify the types of missions/operational situations that are relevant to LMRS, to provide the basis for selecting from among various UUV alternatives (e.g., type of launch and recovery method, autonomous versus tethered operation), to establish performance thresholds and objectives, and to identify key performance/cost/risk issues for LMRS [5].

The LMRS COEA was led by JHU/APL with significant participation by NSWC/CSS, NUWC, NSWC/Carderock Division (CD), and the Applied Research Laboratory of the University of Texas (ARL/UT). The Oversight Board was co-chaired by the Deputy Assistant Secretary of the Navy for Mine and Undersea Warfare (DASN-M/UW) and two flag officers from the Submarine Warfare and Expeditionary Warfare divisions in the Office of the Chief of Naval Operations. The COEA resulted in an Alternative Decision by the Co-Chairs and formed the basis for key portions of the LMRS Program ORD and System Specifications. Contracts were subsequently awarded to three industry teams for Fiscal Year 1997.

#### *A. Operational Need for Clandestine Mine Reconnaissance*

The current MIW Plan reinforces the need for clandestine mine reconnaissance including the following statement:

"Mine reconnaissance is the Navy's highest MIW objective as well as the top UUV priority. Knowledge of the full dimension of the mine threat without exposing the reconnaissance platforms and the intentions of the tactical commander is vital to littoral warfare [3]."

Table 6 summarizes the advantages of clandestine mine reconnaissance in three types of operational circumstances - amphibious assaults, contested choke points and operating areas, and SSN operations in forward areas. Figures 5 through 7 provide examples of these operational settings and delineate the purpose and advantages of the clandestine reconnaissance. The advantages include in all cases a reduction in risk to the reconnaissance assets and maintenance of the operational security needed to ensure mission success for the amphibious force, task group, or

SSN being supported by the reconnaissance effort.

Organic clandestine mine reconnaissance represents a new paradigm compared to that associated with Dedicated MCM forces, as indicated in Table 7. Dedicated MCM forces are typically involved in relatively long duration, non-clandestine operations, i.e., sustained surface MCM use in minehunting/clearance missions and numerous Air MCM sorties for similar missions. The associated minehunting activity emphasizes simultaneous search and classify operations with area coverage rates (ACRs) generally limited by classify sonar performance and potential use of identification sensors (e.g., cameras) at short distances from classified objects. This current paradigm sacrifices ACRs (rapid reconnaissance) for improved clutter management. Conversely, the organic clandestine mine reconnaissance paradigm potentially sacrifices clutter management for improved ACRs (rapid reconnaissance) by more reliance on search sonars than on classify sonars.

### *B. Key COEA Areas of Investigation*

As indicated in Table 8, the following primary investigation areas (alternatives) were evaluated as part of the COEA. These areas directly influenced key measures of effectiveness/performance (MOEs/MOPs) as well as the associated cost analysis:

1. Sensor Options - A variety of search and classification sonars (both forward/ahead-looking and side-looking) were analyzed. These sonars included commercial-off-the-shelf (COTS) systems, military systems currently under development, existing 6.2 research and development (R&D) programs, and potential new developmental systems with R&D legacies. These sonars were evaluated in selected combinations (sensor suite alternatives) to represent various levels of operational performance, cost, and impact on vehicle design/endurance.
2. Energy System Options - More than two dozen energy source technologies were considered in the COEA as shown in Table 9. The technology categories included secondary (rechargeable) batteries, primary (non-

rechargeable) batteries, semi-cell concepts, fuel cell concepts, and advanced thermal and hybrid systems. From this extensive list of candidates, representative energy source technologies were carried forward in the COEA based on performance (e.g., achievable energy densities), development risk, safe use on SSN, affordability, and weight/volume allocations for energy systems on particular UUV designs.

### 3. Vehicle Storage/Launch and Recovery (L&R) Concepts (and Associated UUV Dimensions) -

Three generic vehicle storage/L&R concepts were evaluated in the COEA that would be appropriate for consideration on SSN-688/688I and NSSN platforms (the two types of host platforms targeted by the LMRS Program). The first concept was torpedo tube L&R; this limited UUV dimensions to 21-inch diameter and 240-inch length. The second concept was storage/L&R in a Dry Deck Shelter (DDS). Based on existing DDS dimensions and the need for at least minimal access to the DDS for maintenance, this limited the length of the UUV to 254 inches with potential vehicle diameters of 36 inches (for two UUVs per DDS) and 54 inches (for one UUV per DDS). The third concept was "wet-docking" the UUV outside the SSN hull, a technique used for Navy deep submersibles and the planned Advanced Swimmer Delivery System (ASDS). Nominal sizes for wet-dock UUVs considered in the COEA were 36 by 307 inches (for two UUV systems) and 54 by 540 inches (for single UUV systems).

4. Tethered/Untethered Options - Tethered (semiautonomous) vehicle concepts employed an expendable fiber-optic micro-cable (FOMC), similar to that used in the Near-Term Mine Reconnaissance System (NMRS) Program, to communicate raw unprocessed reconnaissance data from the UUV to the SSN. Tethered mode also allowed "supervisory control" of vehicle operations from the host SSN. In contrast, untethered (autonomous) vehicle concepts precluded real-time supervisory control and real-time access to the UUV's mine reconnaissance data. For autonomous operations, processed reconnaissance data are stored aboard the UUV for post-processing on the host SSN; the data could also be transmitted to the SSN at periodic intervals (e.g., by radio frequency [RF] and/or

acoustic means) during the conduct of the reconnaissance mission.

In addition, several secondary investigation areas (alternatives) were evaluated in the COEA. These secondary areas related to specific design issues or UUV features for which the COEA could provide insights. In general, trade-offs in these areas were analyzed both qualitatively and quantitatively, but in the latter case, not as part of the mainstream analysis (highest level MOEs). These specific design issues/features included UUV depth capabilities (maximum vehicle depth and minimum water depth that the UUV will conduct reconnaissance), maximum vehicle speed, maximum allowable signature levels (to maintain operational stealth and avoid detonating mines), navigation capabilities, and intermittent communication capabilities (needed for untethered vehicles).

In all, more than 150 UUV architecture alternatives were analyzed in the COEA. A specific UUV architecture was primarily determined by its sonar suite, energy system, tethered or untethered operation, and the particular vehicle storage/L&R method (which influenced vehicle dimensions, maintenance options, and other parameters). All of these architecture designs reflected a nominal titanium hull material (to achieve a specified vehicle maximum depth), a nominal navigation suite including Global Positioning System (GPS) antenna, a nominal vehicle acoustic signature (comparable to NMRS), and a nominal communications suite (either FOMC for tethered options or a small RF antenna for autonomous vehicles). Weight and space were also reserved to allow for a potential future identification (ID) sensor upgrade to the vehicle, although design trades for ID were not specifically analyzed in the COEA due to higher priorities. All UUV architectures were subjected to first order design evaluations to establish that they were feasible in terms of weight/volume/power allocations and with respect to maintaining a neutrally buoyant vehicle.

### *C. Key COEA Findings/Conclusions and Associated Technical Issues*

As indicated in Figure 8, the 21-inch torpedo tube launch and recovery alternative was

ultimately selected by the Oversight Board Co-Chairs based on the COEA investigations. It was the preferred alternative because it represented lower cost for "good enough" performance, provided the most flexibility in terms of host SSNs, and had less mission reliability concerns than for DDS or wet-dock options, e.g., involved less risk and associated cost due to the maintenance/replenishment advantages in a torpedo room environment. It was also determined that the 21-inch torpedo tube launched UUV must be autonomous (untethered) due to the competition for available weight/volume. FOMC tether would cut too much into the payload allocation for energy and would significantly nullify the single sortie reach otherwise achievable with advanced energy sources. Single sortie reach for the UUV of 75-120 nautical miles was key to performing the needed two-way reconnaissance probes for more stressing scenarios without having to put the SSN in shallow, potentially mined areas, i.e., providing desired stand-off distances for the host SSN. The required total area coverage (400-650 square nautical miles per mission, including all UUV sorties) and area coverage rate (35-50 square nautical miles per day) capabilities shown in Figure 8 were derived directly from the COEA and have been incorporated into the LMRS ORD.

The following detailed findings and conclusions were drawn from the COEA investigations with the corresponding technical issues or engineering challenges apparent:

1. Sensors: Advanced forward-looking search sonars featuring wide fields of view, appropriate pulse selections, and narrow receive beams, are the preferred UUV sensor to achieve high search rates ( $\geq 35$  square nautical miles per day for the conditions examined), obstacle avoidance for the vehicle, mine avoidance to enhance UUV survivability in minefields, and good ability to select mine-free lanes. In the latter case, a 0.5-0.9 probability of finding mine-free lanes based on search only operations occurred, with success varying according to the exact conditions, i.e., clutter levels, type of acoustic environment, required lane width, mine types/densities, and minefield geometries (Figure 9 indicates the variety of geometries examined). These results should be viewed as conservative since no real pattern recognition methods were employed in

the analysis beyond simple cluster/density recognition.

Using classify sonars to declutter search sonar contacts demonstrated potential payoff in each of the scenarios evaluated, i.e., resulting in a 5-60% increase in finding mine-free lanes depending on the particular conditions and time allowed for decluttering. Only selective (judicious) employment of classify sonars is desired in order to maintain high overall search rates. The combination of target "highlights" and "shadow" was generally needed for reliable classification of bottom or near-bottom mines.

From the COEA investigations, the following sensor related technical issues or engineering challenges were evident:

a. Maintaining significant search swaths even for adverse environments including high reverberation and/or multipath conditions.

b. Achieving moderate search speeds (up to 7-10 knots) without significant degradation from self/flow noise.

c. Achieving adequate search sonar resolution/computer aided detection (CAD) "discriminants" to adequately manage the clutter (without supervisory control).

d. Designing enough "intelligence" into an autonomous (untethered) vehicle to reliably and efficiently relocate previous detected objects, i.e., for the purpose of classifying those objects.

e. Developing reliable computer aided classification (CAC) algorithms for autonomous vehicles.

f. Developing advanced tactical decision aids (TDAs) to optimize the selection of transit lanes (routes) or operating areas based on mine reconnaissance information.

g. Designing low probability of exploitation (LPE) features into the UUV sonars to limit their counterdetectability at tactically significant ranges.

h. Reducing the weight/volume/power impact for the sensor suite in order not to

adversely affect UUV endurance, e.g., single sortie reach goals.

2. Energy Systems: High density energy systems ( $\geq 4$  times the energy density of zinc-silver oxide secondary batteries) are required to achieve the single sortie reach goals for a UUV launched from a torpedo tube. The ability to replenish energy sections is key to achieving total area coverage goals in the most cost-effective fashion, i.e., represents a cheaper approach than buying more than the nominal two UUVs per system. From the COEA investigations, the following energy system related technical issues or engineering challenges were evident:

a. Achieving required energy densities within the confines of a 21-inch torpedo tube launched vehicle.

b. Certifying a specific energy source technology for safe use on submarines during both L&R operations and regular storage/maintenance/energy replenishment periods.

c. Developing a method for energy replenishment without the need to significantly tear down the vehicle, e.g., by "swapping out" energy sections.

3. Vehicle Survivability in Minefields: UUV signatures (e.g., acoustic, magnetic) that are consistent with  $\leq 20$ -yard safe keep-out ranges from mines appear sufficient to enhance UUV mine avoidance and to ensure high UUV survivability after numerous mine encounters. In other words, the vehicle needs to be able to approach within 20 yards of an actual mine without detonating it. The associated technical issues or engineering challenges are:

a. Reducing the acoustic signature for the selected energy system/propulsion technologies.

b. Reducing the electromagnetic signature from the hull material and propulsion system.

c. Developing reliable mechanisms to ensure timely in-situ vehicle maneuvers with respect to detected objects, based on ahead-look

search sonar contacts and effective tactical control of the vehicle.

4. Navigation and Communications: The principal COEA finding related to navigation was that for long endurance missions (e.g., 1-2 days), occasional GPS updates are needed to not degrade below required locating accuracies consistent with efficiently relocating previously detected objects (e.g., from earlier sorties). With regard to communications, lack of real-time ("raw") data and supervisory control without FOMC tether appears acceptable for the tactical situations evaluated. However, use of intermittent RF and/or acoustic communications between the host SSN and the vehicle appears desirable for providing vehicle status reports, CAD "calls", and possibly "snippets" of CAC data. The associated technical issues or engineering challenges are:

a. Achieving reliable GPS updates even in moderate sea states.

b. Achieving reliable communications with the host SSN at significant separation distances (comparable to vehicle single sortie reach).

c. Developing LPE features into the communications suite that are consistent with the clandestine nature of the mine reconnaissance operation.

5. Vehicle Reliability: To achieve high mission reliability for long endurance autonomous operations (1-2 days), nearly an order of magnitude reduction in vehicle failure rates will be needed in comparison to other offboard vehicles such as NMRS or the MK 30 Mod 2 ASW target. For 21-inch torpedo launched vehicles, this appears to be both feasible and affordable but there are still the following issues/challenges:

a. Finding the best combination of fault tolerant/redundant/high quality components that reduces failure rates without adversely impacting vehicle payload.

b. Developing effective maintenance procedures in the torpedo room (including for energy replenishment) to allow achieving high

mission reliability over multiple sorties of the same vehicle.

c. Developing reliable techniques for UUV recovery onboard the SSN.

6. Overall Risk/Cost Drivers: Vehicle reliability, sonar suite development and design (including CAD/CAC software), and introduction of safe, high density, replenishable (onboard the SSN) energy systems are the three primary areas likely to influence overall program risk and cost. These areas warrant continued investigation for risk and cost reduction.

#### IV. SUMMARY OF PERVASIVE TECHNICAL ISSUES RELATED TO ORGANIC MCM

From a review of the studies summarized in Table 4 including the two studies that were highlighted in this paper, a number of technical issues appear to be pervasive or at least common to several programs. Table 10 provides a reminder of current organic MCM approaches that are applicable to U.S. Navy warships. For surface combatants, a primary difference between existing ships and new construction ships is that in the case of the latter, it is doubtful that a "Kingfisher" type onboard sonar would be seriously considered. It is useful as a stopgap measure for existing ships, but not sufficiently capable to justify inclusion in a new construction ship. Another difference between the two categories of ships is in the area of signature reduction and control (not explicitly shown in the table). For existing ships, only modest reductions in acoustic and/or magnetic signatures are likely to prove affordable; whereas, significant reduction efforts (e.g., advanced degaussing systems) could prove affordable if designed into a new ship class. Both existing ships (with enough service life remaining to warrant) and new construction ships could have helicopters with acoustic (modifications to the dipping sonar) and/or non-acoustic (laser systems) upgrades; and both ship categories could also be updated to handle offboard vehicles such as RMS.

For SSNs, similar constraints would be evident in terms of platform signature reduction and control with acoustics quieting likely to be



driven by other considerations related to antisubmarine warfare (not necessarily by MCM). The large sail array being developed as part of the High Frequency Sonar Program (HFSP) would be applicable to existing submarines with adequate remaining service life and to new submarines such as the NSSN class. AMDS, based on the results of various COEAs, appears to be primarily applicable to new construction SSNs. LMRS is being designed with both existing SSN-688/688I and the NSSN classes in mind (including possibly different L&R methods for the two classes). NMRS is not shown because it is a one of a kind operational prototype, i.e., largely a stopgap system prior to introduction of LMRS into the fleet.

For both surface combatants and SSNs, the number of offboard systems (RMS, LMRS) that will ultimately be procured and how many ships are likely to get onboard sonar upgrades are primarily affordability issues. The key technical issues common to various onboard sonar programs and/or offboard vehicles are as follows:

1. Development of reliable computer aided detection algorithms for search sonars to enhance clutter discrimination (to avoid a sea full of clutter objects and a potential grid-lock situation) is perhaps the most pervasive issue as is apparent by examining the Organic MCM programs shown in Table 11. Many organizations are working the CAD issue (mostly involving operator supervision); LMRS is working the same problem for an autonomous vehicle, i.e., making correct CAD calls and managing the clutter. The key will be the ability to generally discriminate "man-made" from "natural" objects that are detected using advanced signal processing techniques to reject most rock outcroppings but not to reject mine cases or anchors or even 55-gallon drums.

2. Similarly, the development of computer aided classification (CAC) and computer aided identification (CAI) algorithms will also be key to certain offboard vehicle systems that are emphasizing these functions, e.g., the RMS program. Once again, for autonomous vehicles such as LMRS without supervisory control, it is even more challenging to ensure that the vehicle makes the necessary maneuvers and gathers the right snippets of

information to optimize the probability of correct classification (determination of whether the object is mine-like or not).

3. Another pervasive issue for search sonars is their ability to exploit multipath, i.e., after how many boundary interactions is the target echo return no longer coherent? This is a potential "show-stopper" for sonars onboard surface ships in shallow water (e.g., 50-100' of water). The detection ranges that can be achieved may not be adequate to allow for timely ship avoidance maneuvers designed to prevent the ship from getting too close to influence mines. For offboard vehicles it could be more of a "show-slower" by effectively reducing area coverage rates.

4. A final set of issues relates exclusively to offboard vehicles. These include high mission reliability for long endurance reconnaissance operations, precise navigation to support follow-up classification/identification/neutralization operations, safe and high density energy sources (particularly for UUVs), and signature reduction/control to enhance vehicle survivability during mine reconnaissance missions. The signature reduction/control issue has already been discussed for UUVs operating near the bottom, but it may be even more acute for semi-submersibles, e.g., relying on diesel engines compared to battery or semi-cell/fuel cell systems on UUVs. This is particularly true if the semi-submersible is in relatively shallow water (e.g., 40-80' of water) and thus potentially vulnerable to mines throughout the water column (not just mines near the surface).

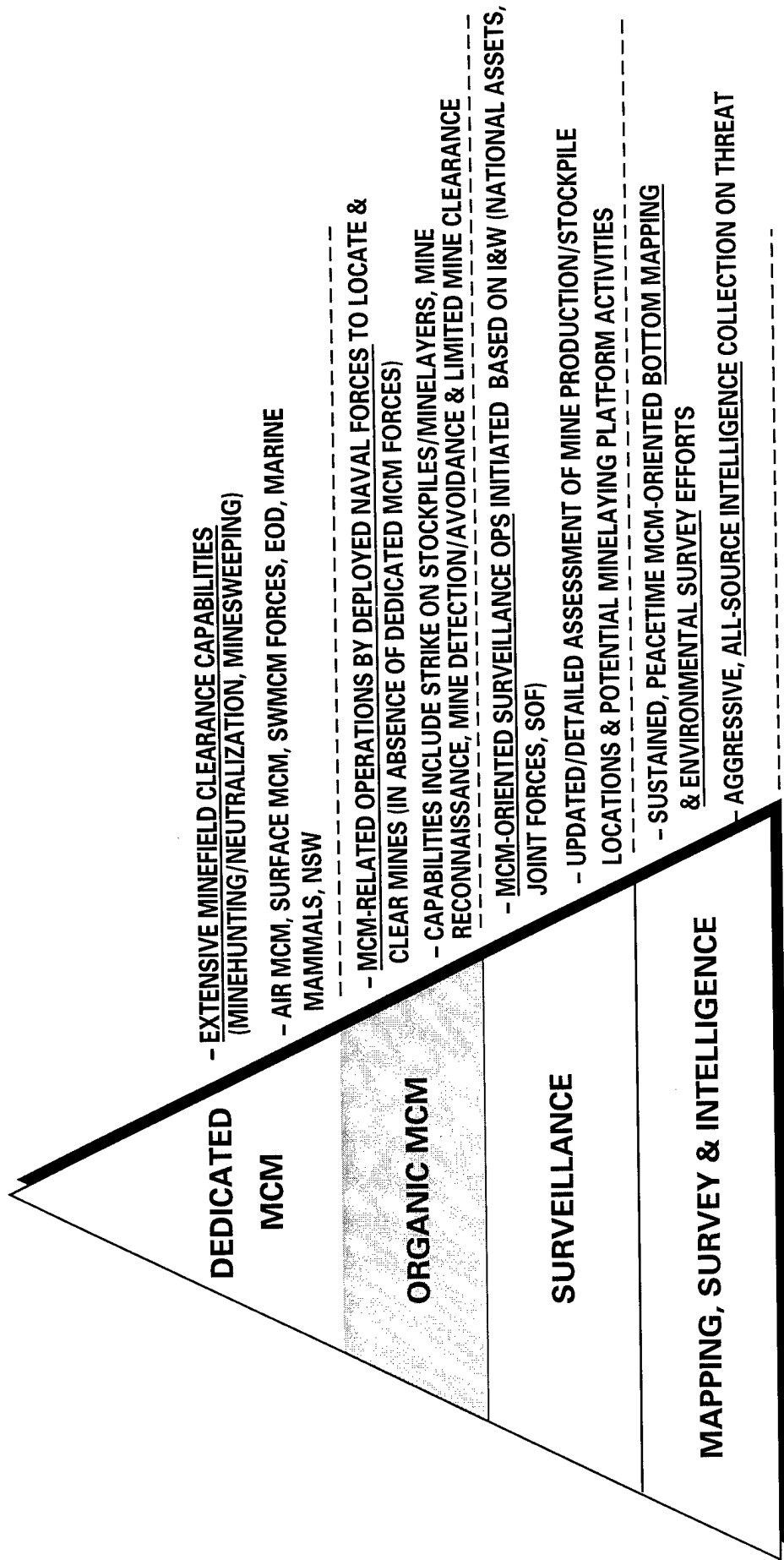
As a final note, it is interesting to speculate on where the next "leap-ahead" technologies are likely to come related to Organic MCM forces. SSN programs related to both onboard sonars (LSA, AMDS) and offboard vehicles (NMRS, LMRS) are under development and will be reaching full maturity during the next decade. Surface combatant and helicopter programs are embryonic by comparison with the notable exception of RMS which is relatively well funded. Onboard sonar upgrades beyond Kingfisher and helicopter upgrades (acoustic, laser) are mostly unfunded at this time. This may change after completion of the SC-21 COEA, which could give impetus to surface/helo MCM initiatives. Thus, surface combatants and

the helicopters deployed from them represent a largely unharvested area in Organic MCM with much room for technology advances - in terms of signature reduction (e.g., advanced degaussing systems), advanced onboard sonars with sophisticated CAD techniques, advanced sensor packages and signature reduction techniques for offboard vehicles, and various helicopter related initiatives (e.g., for the SH-60R) ranging from multi-spectral sensor suites to airborne mine neutralization devices. Organic MCM appears to be a growth industry and the extent of growth will be constrained by two primary factors: funding priorities and technology. We cannot control the former, but we need to keep working on the latter to ensure that no technology breakthroughs are overlooked when it comes to countering mines in future littoral environments.

#### REFERENCES

- [1] J. M. Boorda, "Mine Countermeasures - An Integral Part of Our Strategy and Our Forces," 1995 white paper issued by the Chief of Naval Operations (CNO).
- [2] J. M. Myatt, P. J. Coady, and D. A. Jones, "Organic Offboard Mine Reconnaissance Concept of Operations," 5 May 1995 Memorandum (Ser N852J/5U655273) issued by N85, N86, and N87 Divisions within the Office of the Chief of Naval Operations.
- [3] J. M. Boorda, and C. C. Krulak, "United States Naval Mine Warfare Plan - Third Edition, Fiscal Year 1996-1997 Programs," issued by N85 Division of the Office of The Chief of Naval Operations and endorsed by the CNO and the USMC Commandant, April 1996.
- [4] J. R. Benedict, "FFCOMAR Study Final Brief," issued by PEO(USW) in a 24 May 1995 Memorandum (Ser PMO403D2/C007).
- [5] J. R. Benedict, "The LMRS Program COEA Findings," 7 February 1996 Briefing given to industry at the Johns Hopkins University Applied Physics Laboratory (JHU/APL).

# U.S. NAVAL MINE WARFARE PLAN (APRIL 1996) - CONCEPT OF OPERATIONS (CONOPS)



# CURRENT MCM CAPABILITIES UNDER DEVELOPMENT FOR KEY CONOPS COMPONENTS

<ul style="list-style-type: none"> <li>• <u>SURVEILLANCE/INTELLIGENCE</u> <ul style="list-style-type: none"> <li>- COBRA BEACH RECON (UAV)</li> <li>- RADIANT CLEAR, COASTAL DEFENSE INTEL (NATIONAL)</li> </ul> </li> <li>• <u>MAPPING/SURVEY</u> <ul style="list-style-type: none"> <li>- HF SONAR UPGRADES FOR BOTTOM MAPPING (SUB)</li> </ul> </li> <li>• <u>DEDICATED MCM SYSTEMS</u> <ul style="list-style-type: none"> <li>- SABRE LINE CHARGE IN SURF (MCAC)</li> <li>- ALISS INFLUENCE SWEEP (MHC, MCAC, AIR)</li> <li>- VSW MCM UNIT (DIVERS, MAMMALS)</li> <li>- DISTRIBUTED EXPLOSIVE TECHNOLOGY (MCAC)</li> <li>- EXPLOSIVE NEUTRALIZATION ATD, SURF/BEACH (LCAC)</li> <li>- FACDAR TRANSPORTABLE RANGE (ACOUSTICS/MAGNETICS)</li> <li>- OBSTACLE BREACHING SYSTEM, SURF/BEACH</li> <li>- MAGNETIC CABLE IMP. TO MK 105 SLED (AMCM)</li> <li>- AN/AQS-20 MINEHUNTING SONAR (AMCM)</li> <li>- AMNS EXPENDABLE MINE NEUTRALIZATION DEVICE (AIR)</li> <li>- VARIOUS EXPLOSIVE ORDNANCE DISPOSAL (EOD)</li> </ul> </li> </ul>	<ul style="list-style-type: none"> <li>• <u>ORGANIC MCM SYSTEMS</u> <ul style="list-style-type: none"> <li>- RMS OFFBOARD MINE RECON (SHIP)</li> <li>- NMRS UUV FOR MINE RECON (SUB)</li> <li>- LMRS UUV FOR ADV. MINE RECON (SUB)</li> <li>- RAMICS R&amp;D PROGRAM: ANTI-MINE MUNITION (AIR)</li> <li>- ADVANCED DEGAUSSING AIDS (SHIP)</li> <li>- HF UPGRADES TO BQ5-15 &amp; BSY-1 (SUB)</li> <li>- AMDS, MINE-LIKE DETECTION/AVOIDANCE (SUB)</li> <li>- ALMDS MINE RECON W/LASER (AIR)</li> </ul> </li> <li>• <u>USMC SYSTEMS</u> <ul style="list-style-type: none"> <li>- JAMC REMOTE-CONTROLLED TRACTORS, LANDMINE CM</li> <li>- MACS MAGNETIC INFLUENCE, LANDMINE CM</li> <li>- SMB EXPLOSIVE NET, BREACH LANE CM (W/ARMY)</li> <li>- CBV MINE PLOW BREACHING CAPABILITY</li> <li>- APOBS LINE CHARGE TO BREACH ANTI-PERSONNEL MINEFIELDS/WIRE OBSTACLES (W/ARMY)</li> </ul> </li> </ul>
--	--

**SOURCE: APPENDIX C OF APRIL 1996 MIW PLAN**

9603676A.UW  
Table 1

# COUNTER-MINE REQUIRED CAPABILITY CATEGORIES

<p style="text-align: center;"><b>GENERAL MCM TO SUPPORT VARIOUS FORCES (SHALLOW WATER, DEEP WATER)</b></p> <ul style="list-style-type: none"> <li>↳ • <u>RAPID RECONNAISSANCE &amp; ASSESSMENT OF MINE THREAT (POSSIBLY CLANDESTINE)</u></li> <li>• <u>CLEARANCE OF SEA MINE THREAT</u> <ul style="list-style-type: none"> <li>- VIA DETECTION/NEUTRALIZATION/ SWEEPING</li> <li>- INCLUDING RAPID BREAKTHROUGH OF CHOKE POINTS</li> </ul> </li> <li>↳ • <u>ORGANIC MINE DETECTION &amp; AVOIDANCE</u> <ul style="list-style-type: none"> <li>- FOR CVBG &amp; ATF ASSETS</li> <li>- PLUS OTHER MEANS OF SELF-PROTECTION FROM MINES</li> </ul> </li> </ul>	<p style="text-align: center;"><b>SWMCM TO SUPPORT AMPHIBIOUS ASSAULTS (BEACH, SURF, VSW, SW)</b></p> <ul style="list-style-type: none"> <li>↳ • <u>ACCURATE &amp; TIMELY CLANDESTINE RECONNAISSANCE OF MINES &amp; OBSTACLES</u></li> <li>• <u>MINE/OBSTACLE CLEARANCE OF LANDING AREA</u> <ul style="list-style-type: none"> <li>- EITHER CLANDESTINE OR WITHIN TIME CONSTRAINTS FOR THE ASSAULT</li> </ul> </li> <li>• <u>ACCURATE LANE MARKING OF LANDING AREA</u> <ul style="list-style-type: none"> <li>- EITHER CLANDESTINE OR</li> <li>- CONTIGUOUS WITH CLEARANCE/ASSAULT</li> </ul> </li> </ul>
---	---

↳ PRINCIPAL PERCEIVED CAPABILITIES  
RELATED TO ORGANIC MCM

SOURCE: MNS FOR MCM;ORDs FOR SWMCM

9602722.UW  
REF 9401379A.UW  
Table 2

# RECONNAISSANCE/AVOIDANCE RELATED MCM ASSETS AND ASSOCIATED ROLES

## DEDICATED MCM (NON-CLANDESTINE)

- ASSETS: AIR MCM, SURFACE MCM, SWMCM FORCES, EOD, MARINE MAMMALS, NSW
- KEY FUNCTIONS: MINEHUNTING/NEUTRALIZATION & MINESWEEPING (INCLUDING ASSOCIATED RECONNAISSANCE)
- KEY MCM ROLES:

SWMCM BREACHING OPS  
SLOC/OPAREA CLEARANCE OPS  
PORT CLEARANCE OPS

## ORGANIC MCM (CLANDESTINE)

- ASSETS: SSNs, UUVs, NATIONAL, AIR (E.G., UAVs)
- KEY FUNCTIONS: RECONNAISSANCE & AVOIDANCE
- KEY MCM ROLES:

RECON FOR AMPHIBIOUS ASSAULTS  
RECON IN HIGHLY CONTESTED SLOCs/OPAREAs\*  
RECON/AVOIDANCE FOR SSN OPS

\* PRIOR TO ADEQUATE SUPPRESSION OF ADVERSARY COASTAL DEFENSES

## ORGANIC MCM (NON-CLANDESTINE)

- ASSETS: SURFACE COMBATANTS, SEMI-SUBMERSIBLES, HELOS
- KEY FUNCTIONS: RECONNAISSANCE & AVOIDANCE
- KEY MCM ROLES:

RECON IN AOA (BEYOND ADVERSARY HORIZON)  
RECON IN LESS CONTESTED SLOCs/OPAREAS  
RECON/AVOIDANCE FOR SURFACE COMBATANT OPS

FUNCTIONAL OVERLAP IS EVIDENT FOR VARIOUS MCM ASSETS BUT ASSOCIATED MCM ROLES ARE VERY DISTINCT

# **CLANDESTINE vs. NON-CLANDESTINE MINE RECONNAISSANCE**

<b>• TO SUPPORT CLANDESTINE MINE RECON OPERATIONS</b>	<b>• TO SUPPORT NON-CLANDESTINE MINE RECON OPERATIONS</b>
<ul style="list-style-type: none"> <li>- SSN</li> </ul>	<ul style="list-style-type: none"> <li>- SURFACE SHIP</li> </ul>
<ul style="list-style-type: none"> <li>- UUV (AUTONOMOUS OR SEMI-AUTONOMOUS)</li> </ul>	<ul style="list-style-type: none"> <li>- SEMI-SUBMERSIBLE (WITH OPERATOR SUPERVISION)</li> </ul>
<ul style="list-style-type: none"> <li>- VERY INTERMITTENT COMMS (ACOUSTIC AND/OR RF)                             <ul style="list-style-type: none"> <li>• STATUS CHECKS</li> <li>• NON-REAL TIME RECON DATA</li> </ul> </li> </ul>	<ul style="list-style-type: none"> <li>- CONTINUOUS RF COMMS                             <ul style="list-style-type: none"> <li>• SYSTEM STATUS REPORTS</li> <li>• RECON DATA IN REAL-TIME TO OPERATOR ON SURFACE SHIP</li> </ul> </li> </ul>

# RECENT STUDY EFFORTS RELATED TO ORGANIC MCM RECONNAISSANCE AND/OR AVOIDANCE

STUDY	LEAD ORGANIZATION	KEY SUPPORTING ORGANIZATIONS	OFFBOARD MINE RECONNAISSANCE	ONBOARD MINE DETECTION/AVOIDANCE
• SOMSS COEA	JHU/APL	NUWC, NSW/CSS, ARL/UT	✓	✓
• BSY-1 HF UPGRADE COEA	JHU/APL	NUWC, ARL/UT		✓
• NAS COEA	CNA	NSWC/CD		✓
• NSSN COEA	NUWC	JHU/APL, NSW/CSS/CD		✓
• LMRS COEA	JHU/APL	NUWC, NSW/CSS, ARL/UT, NSW/CSS/CD	✓	
• FFCOMAR STUDY	JHU/APL	NUWC, NSW/CSS	✓	✓
• RMS COEA	NSWC/CSS	-	✓	
• ALMDS COEA	NSWC/CSS	-	✓	
• SC-21 COEA (ON-GOING)	CNA	JHU/APL, NSW/CSS	✓	✓





# SPECIFIC SYSTEM ALTERNATIVES EVALUATED IN FFCOMAR STUDY

<ul style="list-style-type: none"> <li>• <u>ONBOARD SONAR ALTERNATIVES</u></li> <li>– SOS-53 KINGFISHER</li> <li>– KINGFISHER AUGMENTED WITH TARS**</li> <li>– AMDS ("CHIN ARRAY") EQUIVALENT</li> <li>– BOA/SWAT TOWED SYSTEM**</li> </ul>	<ul style="list-style-type: none"> <li>• <u>OFFBOARD VEHICLE ALTERNATIVES</u></li> <li>– RMOP</li> <li>– NOTIONAL RMS***</li> <li>– NMRS</li> <li>– NOTIONAL LMRS VARIANTS***</li> </ul>
<ul style="list-style-type: none"> <li>• <u>SHIP SIGNATURE REDUCTION ALTERNATIVES</u></li> <li>– ADVANCED DEGAUSSING*</li> <li>– ADVANCED ACOUSTIC SIGNATURE REDUCTION*</li> <li>– ACOUSTIC SIGNATURE REDUCTION (P3I)**</li> </ul>	<ul style="list-style-type: none"> <li>• <u>HELICOPTER SYSTEM ALTERNATIVES</u></li> <li>– ALFS VARIANT (KF ADAPTATION)</li> <li>– ATD-111**</li> <li>– ALMDS (NOTIONAL)</li> </ul>

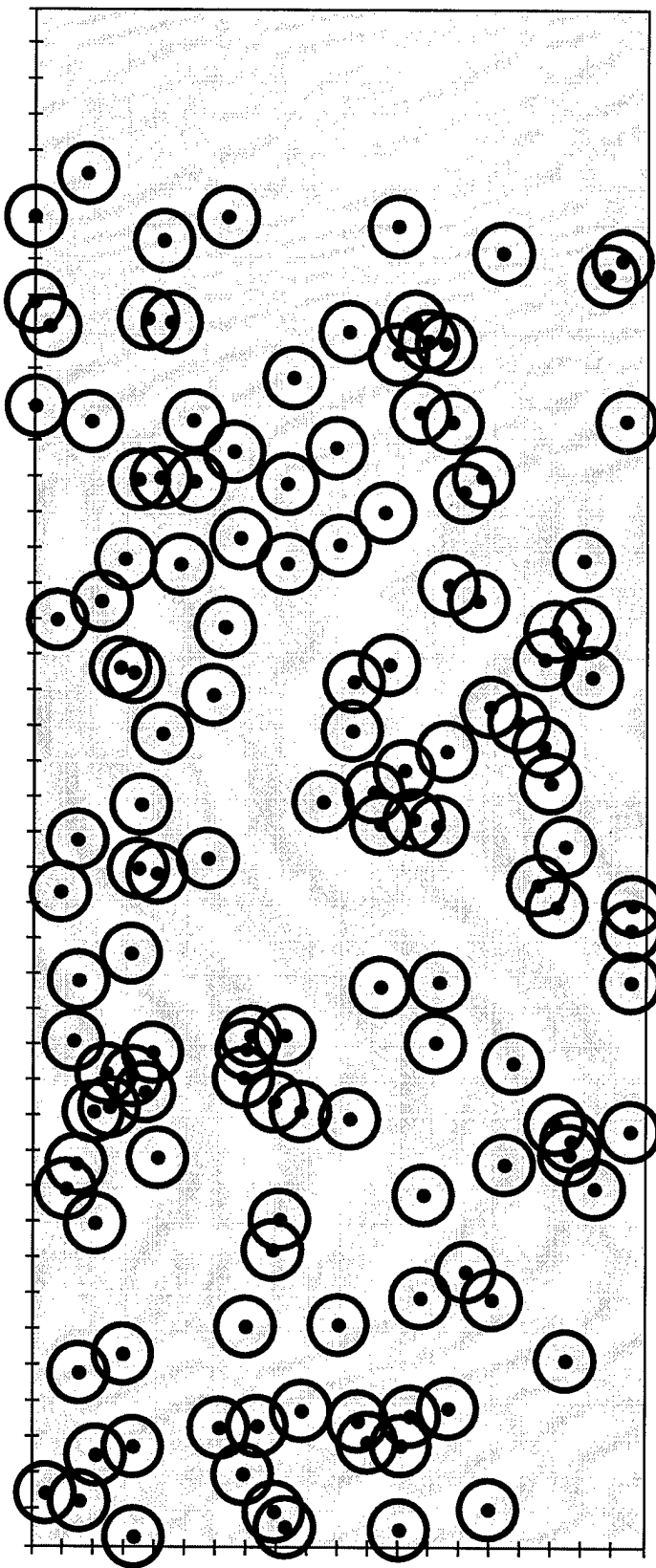
\* APPLICABLE TO NEW CONSTRUCTION SHIPS (E.G., SC-21)

\*\* FILTERED AFTER SENSOR LEVEL ANALYSIS

\*\*\* PRIOR TO COMPLETION OF RESPECTIVE COEA EFFORTS

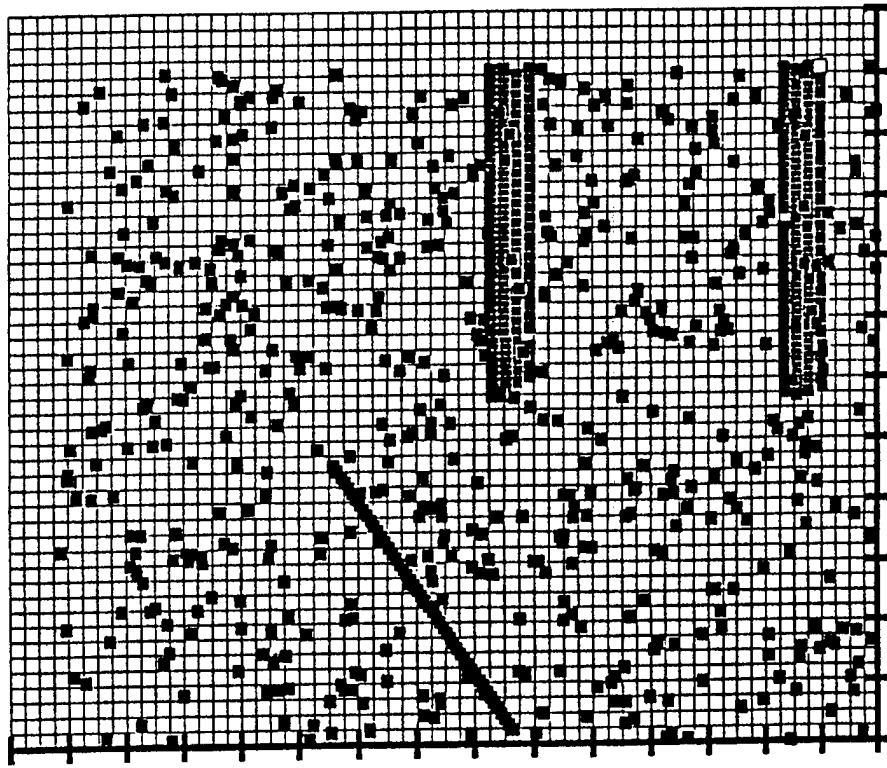
9500100B.UW  
Table 5

**SAFE TRANSIT/PATROL PROBLEM  
FOR 16 CLUTTER OBJECTS PER  
SQ. NMI & 200 YD KEEP-OUT RANGES**



**REPRESENTS MUCH POTENTIAL MANEUVERING AGAINST CLUTTER,  
E.G., NON-MINE BOTTOM OBJECTS - COUNTERPRODUCTIVE IF ONBOARD SONAR  
NOT CAPABLE AGAINST ACTUAL BOTTOM MINES**

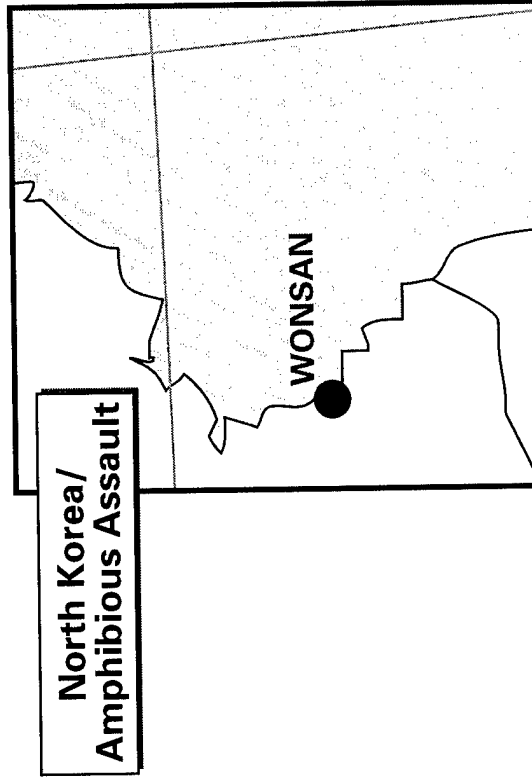
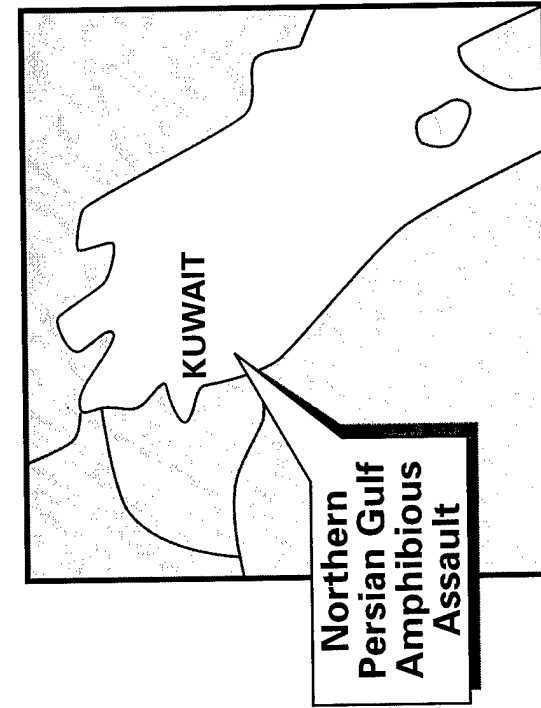
# ILLUSTRATION OF DETECTED OBJECTS DURING RECON MISSION



# ADVANTAGES OF CLANDESTINE MINEFIELD RECONNAISSANCE

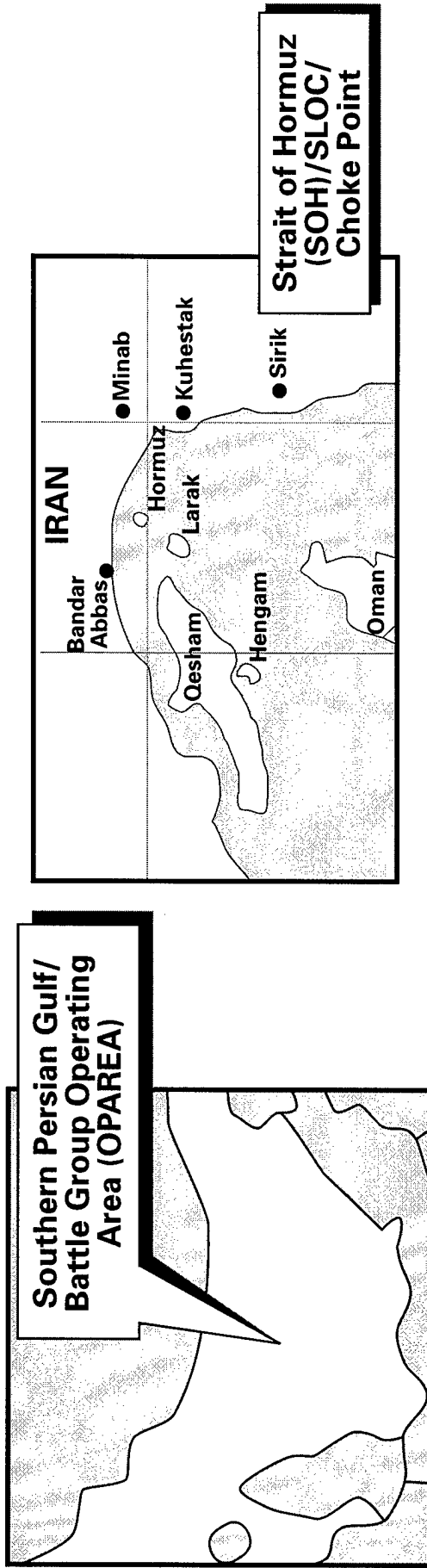
ADVANTAGE	AMPHIBIOUS ASSAULTS	CONTESTED CHOKE POINTS & OPERATING AREAS	SSN OPS IN FORWARD AREAS
<ul style="list-style-type: none"> <li>• TO MINIMIZE RISK OF LOSSES TO RECON ASSETS</li> </ul>	✓	✓	✓
<ul style="list-style-type: none"> <li>• TO MAINTAIN NEEDED OPERATIONAL SECURITY FOR MISSION SUCCESS               <ul style="list-style-type: none"> <li>- BY AVOIDING CUES TO ADVERSARY COASTAL DEFENSES (e.g., LOCATION/TIMING OF INTENDED OPS)</li> <li>- BY ACHIEVING OPERATIONAL &amp; TACTICAL SURPRISE FOR AS LONG AS POSSIBLE</li> <li>- BY AVOIDING COMPROMISE TO SUBMARINE STEALTH</li> </ul> </li> </ul>	✓	✓	✓

# **AMPHIBIOUS ASSAULT EXAMPLES BENEFITING FROM CLANDESTINE MINE RECONNAISSANCE**



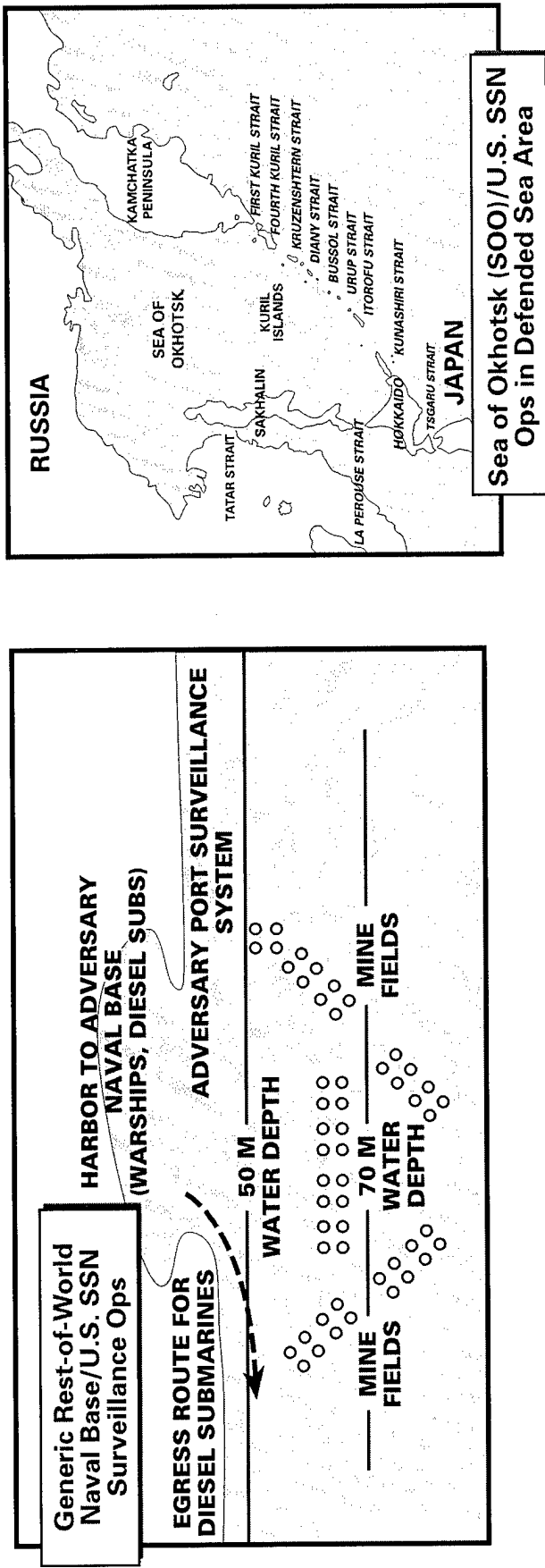
- CLANDESTINE MINE RECONNAISSANCE (DURING WEEKS PRIOR TO ASSAULT):
  - SUPPORTS SELECTION OF TRANSIT/ASSAULT LANES
  - PROVIDES FOCUS TO MCM CLEARANCE/BREACHING EFFORTS
- WITHOUT FOLLOWING DISADVANTAGES:
  - ALERTING COASTAL DEFENSES TO TIMING/LOCATION OF ASSAULT
  - EXPOSING MINE RECON ASSETS TO COUNTERATTACKS

# CONTESTED CHOKES POINT & OPERATING AREA EXAMPLES BENEFITING FROM CLANDESTINE MINE RECONNAISSANCE



- CLANDESTINE MINE RECONNAISSANCE (PRIOR TO SUPPRESSING ADVERSARY COASTAL DEFENSES AND GAINING BATTLESPACE DOMINANCE):
  - SUPPORTS SELECTION OF TRANSIT ROUTES/OPAREAS BASED ON PERCEIVED MINE DANGER AREAS
  - PROVIDES FOCUS TO MCM CLEARANCE/SWEEPING EFFORTS
- WITHOUT FOLLOWING DISADVANTAGES:
  - PROVIDING ADVERSARY WITH CUES ON TRANSIT TIMING/ROUTES OR INTENDED BG OPAREA
  - EXPOSING MINE RECON ASSETS TO ADVERSARY COASTAL DEFENSES

# SSN OPERATIONS IN FORWARD AREAS BENEFITING FROM CLANDESTINE MINE RECONNAISSANCE



- CLANDESTINE MINE RECONNAISSANCE (IN SUPPORT OF SSN MISSION):
  - SUPPORT SELECTION OF SSN TRANSIT ROUTE/OPAREA BASED ON PERCEIVED MINE DANGER AREAS
  - ALLOWS SSN TO REMAIN OUTSIDE POTENTIAL MINED AREAS DURING RECON MISSION
- WITHOUT FOLLOWING DISADVANTAGES:
  - ALERTING COASTAL DEFENSES TO SSN PRESENCE/LOCATION (WITH POTENTIAL ADVERSARY COUNTERATTACKS)
  - COMPROMISING SSN OPERATIONAL SECURITY & MISSION ACCOMPLISHMENT

# NEW PARADIGM FOR ORGANIC CLANDESTINE MINE RECONNAISSANCE

<p><b><u>Current Paradigm (NWP-27) For Dedicated MCM Forces</u></b></p> <ul style="list-style-type: none"> <li>• <b><u>Dedicated Mine Countermeasure (MCM) Forces Include:</u></b> <ul style="list-style-type: none"> <li>– Surface MCM (SMCM) Ships</li> <li>– Airborne MCM (AMCM) Helos</li> <li>– MCM Diver Teams</li> </ul> </li> <li>• <b><u>Relatively Long Duration, Non-Clandestine Ops</u></b> <ul style="list-style-type: none"> <li>– Sustained SMCM Mine Hunting/Clearance Missions</li> <li>– Numerous AMCM Sorties for Similar Missions</li> </ul> </li> <li>• <b><u>Emphasis on Simultaneous Search &amp; Classify Ops</u></b> <ul style="list-style-type: none"> <li>– Area Coverage Rates Limited by Classify Sonar Performance</li> <li>– Potential Use of ID Sensors As Well</li> </ul> </li> </ul>	<p><b><u>New Paradigm for Organic Clandestine Mine Reconnaissance Assets</u></b></p> <ul style="list-style-type: none"> <li>• <b><u>Organic Clandestine Mine Reconnaissance Assets Include:</u></b> <ul style="list-style-type: none"> <li>– Submarine (SSN) Host Platforms</li> <li>– Deploying UUVs with Advanced Sonars</li> </ul> </li> <li>• <b><u>Emphasis on Achieving High Clandestine Area Coverage</u></b> <ul style="list-style-type: none"> <li>– Constrained by Limited Numbers of Forward Deployed Clandestine Assets</li> <li>– Need to Compensate with High UUV Area Coverage Rates</li> </ul> </li> <li>• <b><u>High Area Coverage Rates Attained by Relying on:</u></b> <ul style="list-style-type: none"> <li>– Search Ops with Advanced Sonars/CAD Algorithms</li> <li>– Cued Intermittent Use of Classify Sonars</li> </ul> </li> </ul>
--	--

**"We Must Have Organic Sensors, Systems, Tactics, Training, and Planning... to Achieve Mission Objectives Within Desired Timelines."**  
CNO (ADM J.M. Boorda)\*

\* From 1995 White Paper "MCM – An Integral Part of Our Strategy and Our Forces"



# **Key Investigation Areas for Evaluating Unmanned Undersea Vehicle (UUV) Alternatives in LMRS COEA**

<ul style="list-style-type: none"> <li>■ <u>Major Investigation Areas</u> <ul style="list-style-type: none"> <li>◆ Sensor Suite Options for UUV</li> <li>◆ Energy System Options for UUV</li> <li>◆ UUV Storage/Launch and Recovery Options</li> <li>◆ UUV Diameter/Length Options</li> <li>◆ Tethered versus Autonomous UUVs</li> </ul> </li> </ul>	<ul style="list-style-type: none"> <li>■ <u>Directly Influenced Primary MOEs in COEA</u> <ul style="list-style-type: none"> <li>◆ Vehicle Single Sortie Reach (NMI)</li> <li>◆ Total Area Coverage (NMI<sup>2</sup>) Per Mission</li> <li>◆ Area Coverage Rate (NMI<sup>2</sup>/Day)</li> <li>◆ Probability of Selecting Mine-Free Lane</li> </ul> </li> </ul>
<ul style="list-style-type: none"> <li>■ <u>Secondary Investigation Areas</u> <ul style="list-style-type: none"> <li>◆ Navigation Options for UUV</li> <li>◆ Communications Options for Autonomous UUV</li> <li>◆ Allowable UUV Signature Levels</li> <li>◆ Maximum UUV Speed</li> <li>◆ Maximum and Minimum UUV Depths</li> </ul> </li> </ul>	<ul style="list-style-type: none"> <li>■ <u>Off-Line Analyses</u> <ul style="list-style-type: none"> <li>◆ Providing Quantitative/Qualitative Insights to Oversight Board Concerning These Design Trades</li> </ul> </li> </ul>

# REPRESENTATIVE ENERGY SOURCES FOR UUVS CONSIDERED IN LMRS COEA

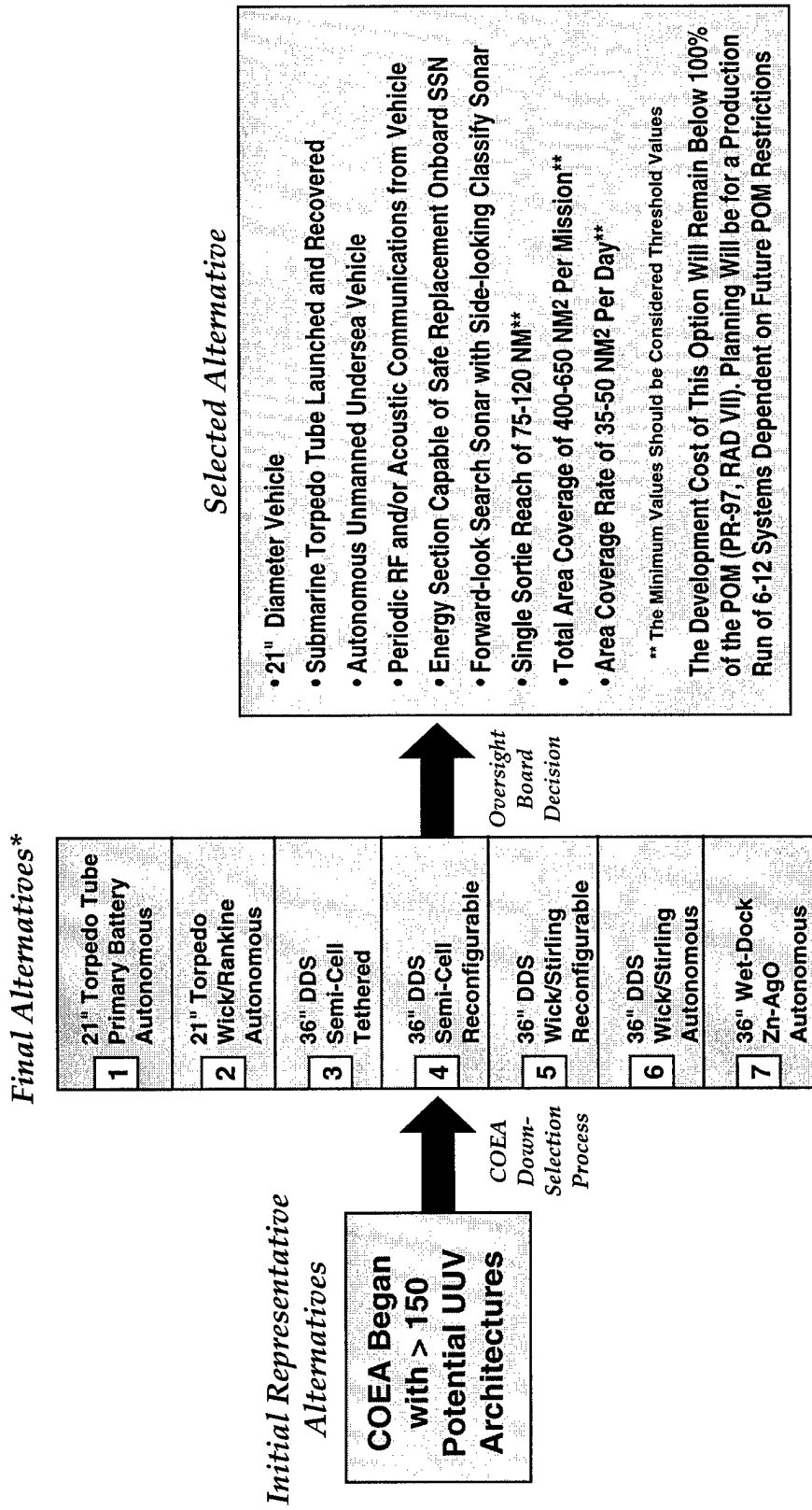
- **Semi-Cell Technology**
  - Aluminum/Oxygen (Al - O<sub>2</sub>) w/Chlorate Candles
  - Aluminum Hydrogen Peroxide (Al - H<sub>2</sub> O<sub>2</sub>)
  - Zinc Oxygen (Zn - O<sub>2</sub>) w/ Chlorate Candles
  - Seawater Oxidized (Al - H<sub>2</sub>O, Li - H<sub>2</sub>O, Mg - H<sub>2</sub>O)
  - Dissolved Oxygen Oxidized (e.g., Mg - H<sub>2</sub>O "Battery")
- **Fuel Cell Technology**
  - PEM\* w/ Rechargeable Fuel Supply (COTS Metal Hydride & Chlorate Candles)
  - PEM\* w/ Replaceable Fuel Supply (Adv. Chemical Hydride & Chlorate Candles)
    - Alkaline
    - Phosphoric Acid
    - Molton Carbonate
    - Monolithic Solid Oxide
- **Secondary (Rechargeable) Batteries**
  - Zinc Silver Oxide (Zn - Ag O)
  - Lithium Cobalt Dioxide (Li - Co O<sub>2</sub>)
  - Sodium Sulfur (Na-S)
  - Lithium Iron Disulfide (Li - Fe S<sub>2</sub>)
  - Lithium Ion (Li/6C - Mx Oy)
- **Primary (Non-Rechargeable) Batteries**
  - Lithium Thiionyl Chloride (Li - SOCl<sub>2</sub>)
  - Lithium Sulfur Dioxide (Li - SO<sub>2</sub>)
  - Lithium Polycarbon Monochloride (Li - CF)
- **Advanced Thermal & Hybrid Systems**
  - JP-5/Gaseous O<sub>2</sub> (OR 60% H<sub>2</sub>O<sub>2</sub>) Closed Rankine Cycle
  - "Wick" Lithium-Sulfur Hexafluoride (Li - SF<sub>6</sub>) Combustor with Stirling Engine
  - "Wick" Li - SF<sub>6</sub> Combustor with Closed Rankine Cycle (Steam Turbine)
  - "Wick" Li - SF<sub>6</sub> Combustor with Closed Brayton Cycle (Gas Turbine)
  - Chemical Gas Generator/Hybrid Solid Oxide Fuel Cell/Rankine Cycle System
  - "Wick"/Hydrox with Rankine Cycle System
  - JP-5/Chemical Oxygen Closed Rankine Cycle
  - Closed Cycle Diesel (CCD) - Various Concepts

**Selection of a Representative Energy Source for a Given Application Depends on Following Considerations:**

- Performance (e.g., Achievable Energy Densities)
- Development Risk
  - Affordability
  - Weight/Volume Margins
- Safe Use on SSN

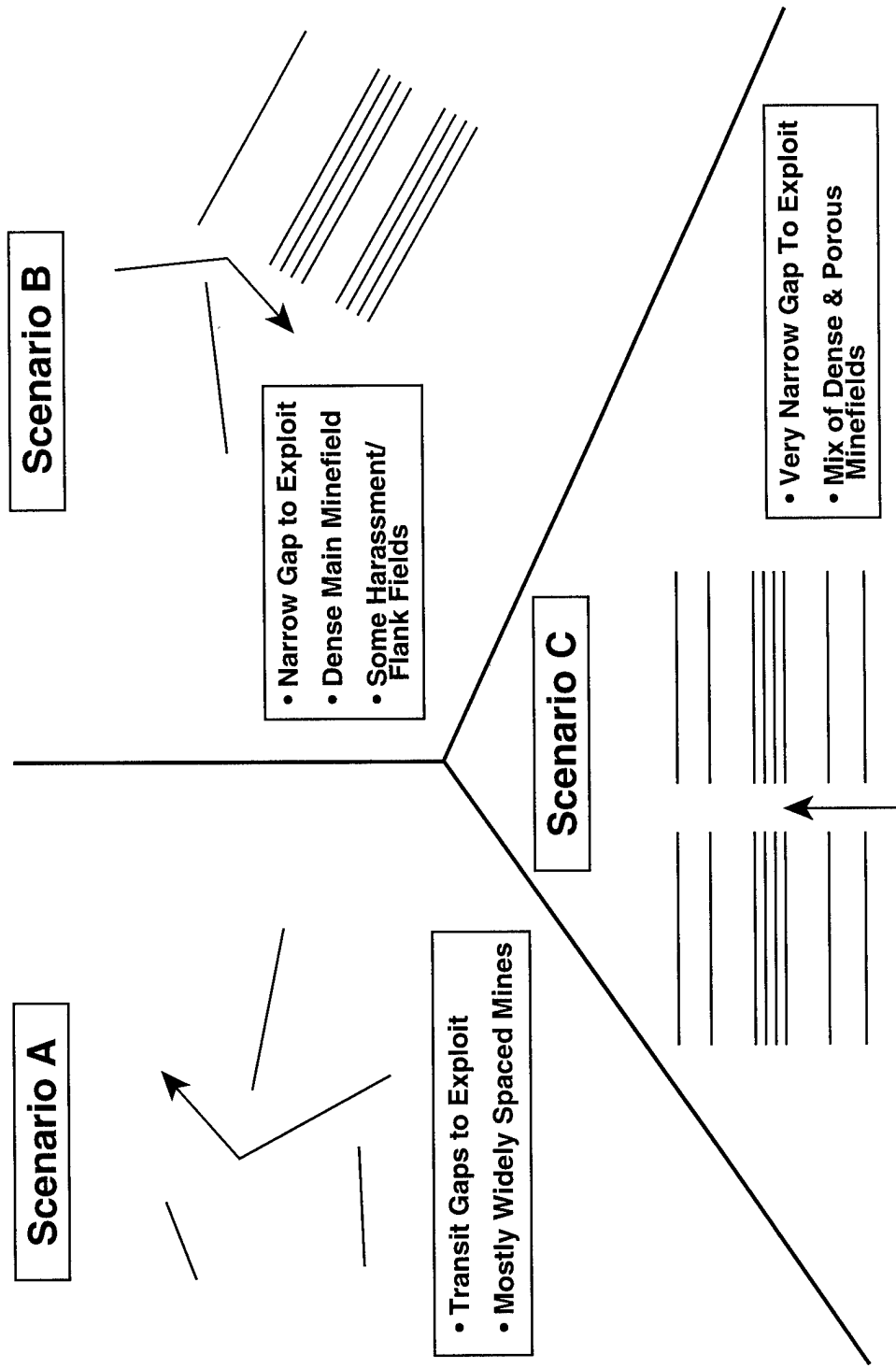
\* Proton Exchange Membrane (PEM)

# SUMMARY OF UUV ARCHITECTURES EVALUATED IN COEA (COEA DOWN-SELECTION & OVERSIGHT BOARD DECISION)



\* (2) Sonar Suites Associated with Each of These Options

# ILLUSTRATION OF VARYING MINEFIELD GEOMETRIES



# CURRENT APPLICABLE ORGANIC MCM APPROACHES FOR U.S. NAVY WARSHIPS

U.S. NAVY WARSHIP	ORGANIC MCM - MINE DETECTION & AVOIDANCE	ORGANIC MCM - OFFBOARD MINEFIELD RECONNAISSANCE
<ul style="list-style-type: none"> <li>• EXISTING SURFACE COMBATANTS</li> </ul>	KINGFISHER OR HF ONBOARD SONAR UPGRADE (AMDS EQUIVALENT)	HELO* AND/OR RMS **
<ul style="list-style-type: none"> <li>• NEW CONSTRUCTION SURFACE SHIPS (E.G., SC-21, LPD-17)</li> </ul>	HF ONBOARD SONAR UPGRADE (AMDS EQUIVALENT)	HELO* AND/OR RMS **
<ul style="list-style-type: none"> <li>• EXISTING SSNs</li> </ul>	BSY-1 HF UPGRADE (HFSP LARGE SAIL ARRAY, LSA)	LMRS **
<ul style="list-style-type: none"> <li>• NEW SSN (NSSN)</li> </ul>	AMDS & LSA	LMRS **

\* POSSIBLY WITH ALMDS AND/OR ALFS MOD (KINGFISHER EQUIVALENT)  
 \*\* IF AVAILABLE (LIMITED BUYS ANTICIPATED)

HOW MANY SHIPS GET ONBOARD SONAR UPGRADES & HOW MANY  
 OFFBOARD VEHICLE SYSTEMS ARE PROCURED REPRESENT AFFORDABILITY ISSUES

# CAD/CAC/CAI DEVELOPMENT (w/ AND w/o AN OPERATOR)

ORGANIC MCM PROGRAM/ TECHNOLOGY	COGNIZANT ORGANIZATION	APPLICABLE COMPUTER AIDED SENSING TECHNOLOGIES			
		CAD w/ OPERATOR	CAD w/o OPERATOR	CAC w/ OPERATOR	CAC w/o OPERATOR
"KINGFISHER" MOD TO SOS-53 & SOS-56	NUWC	✓			CAI w/ OPERATOR
"MAXUS" EC-17 TO BOS-15	ARL/UT	✓			CAI w/o OPERATOR
HFSP LSA UPGRADE TO BSY-1	ARL/UT	✓			
AMDS ON NSSN	NUWC	✓			
NMRS	WESTINGHOUSE	✓		✓	
LMRS	INDUSTRY?		✓	✓	
RMOP/RMS	NSWC/CSS	✓		✓	
RMS UPGRADE	NSWC/CSS	✓		✓	✓
MSS/AMMT (DARPA)	ARL/UT	✓	✓ (MSS/AMMT)	✓ (MSS)	✓ (AMMT)

• ALL HULL-MOUNTED MINE DETECTION/AVOIDANCE SONARS & OFFBOARD VEHICLE MINEHUNTING (MINE RECONNAISSANCE) SONARS RELY ON COMPUTER AIDED DETECTION (CAD) TECHNOLOGIES



# Identification of Underwater Mines via Surface Acoustic Signature

Dale A. Lawrence, Renjeng Su, and Noureddine Kermiche  
Center for Space Construction  
University of Colorado  
Boulder CO 80309-0529

## Abstract

We present in this paper some of our preliminary experimental results of a sensor concept for underwater mine identification. Our motivation is to find new kinds of sensors to complement the existing sensor capability, which is quite limited indeed, for mine identification. The idea is to use the surface acoustics of the objects as a signature to distinguish mines from other mine-like objects. A piezo-electric transmitter and receiver pair is used in our design. Through the transmitter a train of pulses is launched. The received signals give unambiguous signatures which distinguish different material objects.

## I. Introduction

Today the task of underwater mine hunting involves a process of distinguishing mines from mine-like objects. Mine identification is typically done by explosive ordinance divers (EOD) or remotely operated vehicles (ROV) at a close distance. Divers typically use hand-held sonar. Sonar is also the primary sensor for ROV s. Using sonar images to identify real mines can be very unreliable and much depends on human experience and interpretation. There are other types of sensors being explored to provide additional signals for the purpose of underwater mine identification [Ref. 4]. Notably there are laser scanners and magnetic gradiometers currently under development. It may very well be the case that future mine hunting will involve signals from a suite of sensors. And there are likely to be situations where the cost of operations do not allow the use of sophisticated sensors like laser scanning systems or gradiometers. Other low-cost sensors which are easy to operate need be further explored in order to further improve the sensing capability for mine identification. Motivated by this problem we have begun to explore the potential use of the surface acoustics signals of mine-like objects to pick out mines. This sensor concept is inspired by surface acoustic sensor work previously reported. For example, Mills, et. al. experimented with the idea of using the surface acoustics to distinguish wood species [Ref.1].

## II. Two Experimental Concepts

We experimented with two different sensor concepts in our laboratory to measure surface acoustic signals of objects. The first utilized a simple metal stylus instrumented with a force sensor. The intent here was to excite the natural bulk vibration modes of the object, and measure the surface vibration with

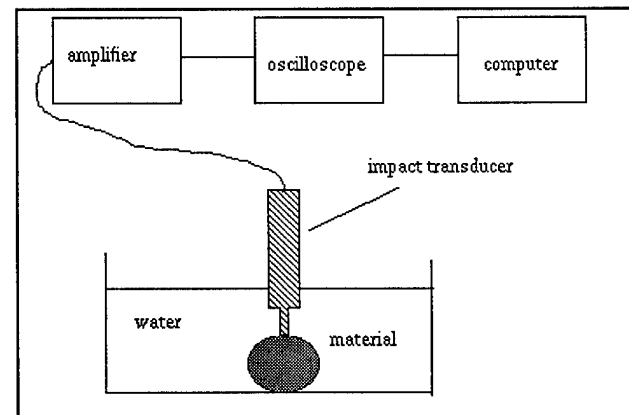


Fig. 1. Basic configuration and instrumentation for impact force measurements.

the force sensor. (See Figure 1.) The stylus was placed firmly against the surface of various small objects in a water tank. The stylus was gently "tapped" to elicit the characteristic structural vibrations. These vibrations are measured by the force sensor and these waveforms are then classified to determine the type of object. This design is similar to the one used in Ref. 1, which can identify specific types of wood species within a narrow class. A similar approach is described in Reference 2 to identify structural cracks in underwater structures of oil platforms. On the other hand, the mine identification problem seems closely related to work in Stress Wave Factors (Ref. 3), which seeks to measure bulk properties of structural members. With this inspiration we devised a second concept using an acoustic sensor as shown in Fig.2. An ultrasonic transducer launches a train of acoustic pulses into the material, and a second transducer measures the resulting reflected waves. This approach attempts to measure the bulk acoustic attenuation/ dispersion/ reflection characteristics of the objects. Characteristic surface acoustic signatures of various mines could be classified and compared with the measured signature of unknown objects of interest to differentiate man-made from natural origins with



high probability. It is also likely that specific types of mines could be identified with this surface acoustic data, possibly using neural network and/or wavelet identification schemes. The main questions to ask in this investigation are: Can these sensors provide useful signatures to distinguish different materials? How would other physical properties of the objects like size and shape alter the signatures? Are the signals useful for identifying particular mine types?

### III. Experimental Results

Surface acoustic signatures of objects may be affected by a large number of possible mechanical properties and morphological conditions. (See Ref. 3) Determining the identity of a particular material involves extraction of unique features in the measured sensor data. The feature extraction and classification can be achieved using various methods that range from classical clustering to artificial neural networks. In our experiment, we used objects of three types of materials: aluminum, plastic and concrete. The impact force and the acoustic transmission results are discussed separately below.

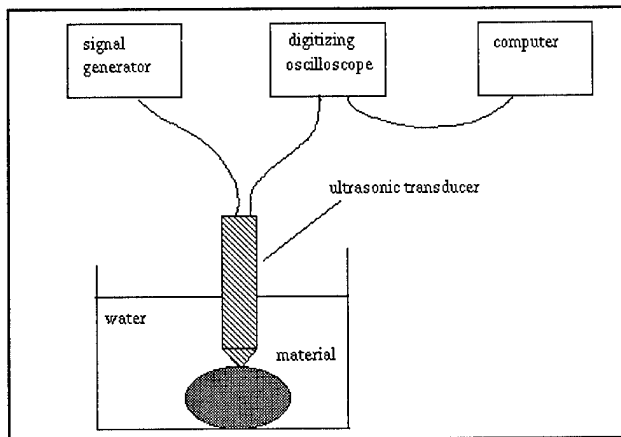


Fig.2. Basic probe configuration and instrumentation for ultrasonic material identification. A digitizing oscilloscope is used to feed time domain signals to the computer for analysis and evaluation of ultrasonic signatures.

#### III.1. Impact Force Sensing Results

Figures 3 to 8 show how the material composition of similarly sized and shaped objects can produce distinct surface force signatures. For example, note the difference in response oscillation frequency and decay time between the concrete and plastic materials (Figures 5 and 7). Figures 3 and 4 show how two similar materials (both metal) can produce quite different surface signatures which are characteristic of the size and shape of the object. On the other hand, the signatures produced by the metal samples have higher dominant frequencies than the concrete blocks. Plastic samples produced

the lowest dominant frequency.

#### III.2. Ultrasonic Sensing Results

Surface acoustic signatures obtained from the ultrasonic sensor are shown in Figures 9 to 14. The time domain data are difficult to distinguish, but differences between object species are more clearly evident in the power spectral densities. In particular, the plastic objects absorb low frequencies (Figures 11 and 12). Concrete blocks absorb well at high frequencies (Figures 13 and 14). Metal objects show strong resonance (Figures 9 and 10). With a simple Euclidean distance measure either in the time or frequency domains objects of like materials can be easily paired. For example, the spectral interdistance matrix shows that the "closest" material to the metal1 is metal2. The same conclusion can be drawn for the plastic and rock species. The time domain matrix gives similar results. It is important to notice that such pairing seems to be quite robust even though objects of like materials differ significantly in size and shape.

FFT inter-distance matrix.

	metal1	metal2	plastic1	plastic2	rock1	rock2
metal1	0	1.85	3.66	3.28	2.91	2.98
metal2		0	3.5	3.68	3.29	3.26
plastic1			0	1.43	2.19	2.08
plastic2				0	1.55	1.51
rock1					0	0.58
rock2						0

Time signal inter-distance matrix.

	metal1	metal2	plastic1	plastic2	rock1	rock2
metal1	0	0.12	0.23	0.21	0.18	0.19
metal2		0	0.22	0.23	0.21	0.21
plastic1			0	0.09	0.14	0.13
plastic2				0	0.1	0.1
rock1					0	0.04
rock2						0

### IV. Conclusion

Our initial laboratory results with the surface acoustic signature were very encouraging. This sensing approach is clearly sensitive enough to produce distinct signatures of different object materials. In the case of force transducers we observed the signature variability due to the size and shapes. These data provide a strong evidence that mine identification sensors based on surface acoustics may be quite feasible. We are currently involved in testing the ultrasonic sensors on

objects with composite materials as a step closer to real mines. We are also investigating the question of which data processing algorithms are most efficient and robust in identifying the object features. With the feasibility data we intend to seek sponsorship for developing an engineering prototype of a surface-acoustic mine sensor. It is our hope that this research will lead to a very low-cost mine identification sensor which can be used either on autonomous mine hunting platforms of the future or for complementing the current sensor capability of EOD's and ROV's.

**References**

- [1] T. P. Mills, et al, " Identification of Wood Species by Acoustic-Resonance Spectroscopy Using Multivariate Subpopulation Analysis", Applied Spectroscopy , Vol. 47, No. 11, 1993, pp. 1880--1886.
- [2] C. Hayward, et al, "An Intelligent Ultrasonic Inspection System for Flooded Member Detection in Offshore Structures", IEEE Trans. Ultrasonics, Vol. 40, No. 5, 1993, pp. 512--521.
- [3] J. C. Duke, Jr. (editor), ACOUSTO-ULTRASONICS Theory and Application, Plenum Press, 1988.
- [4] Proceedings of the Autonomous Vehicles in Mine Countermeasures Symposium, Monterey, CA., 4-7 April 1995.

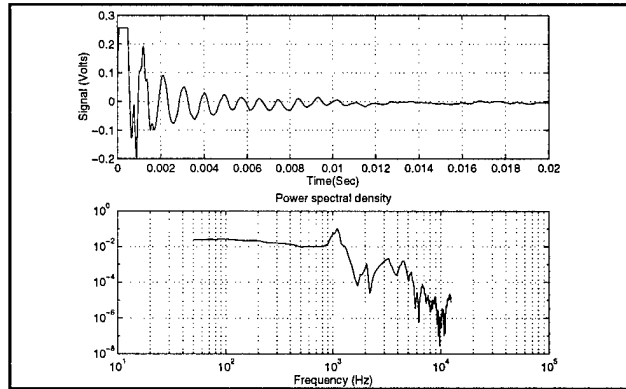


Fig. 3. Impact force response of metal1.

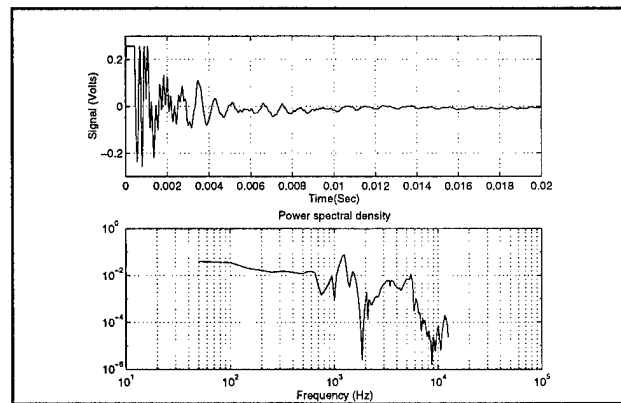


Fig. 4. Impact force response of metal2.

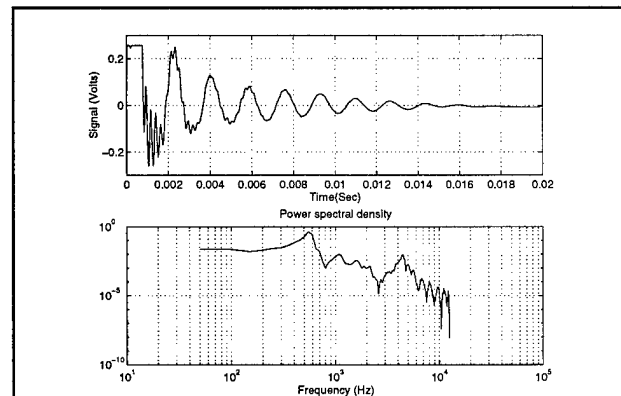


Fig. 5. Impact force response of plastic1.

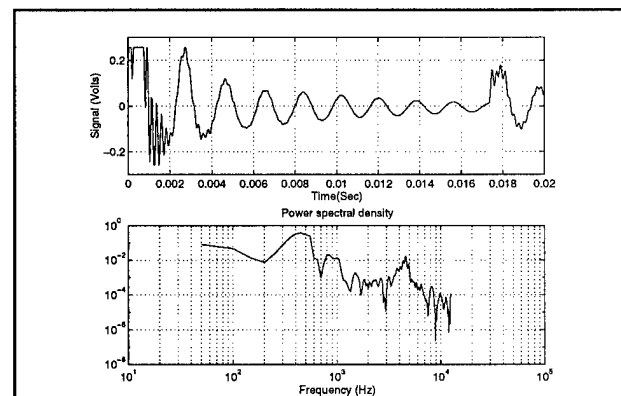


Fig. 6. Impact force response of plastic2.

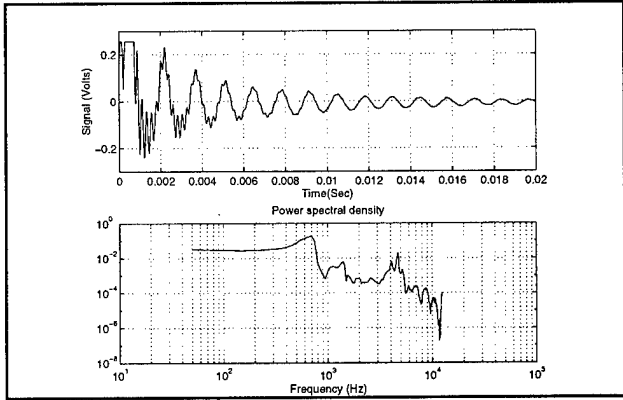


Fig. 7. Impact force response of rock1.

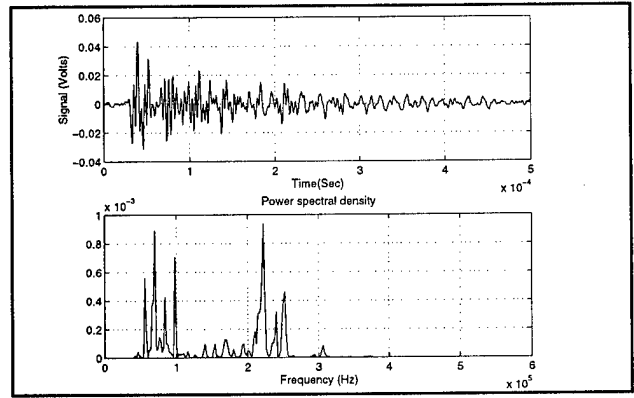


Fig. 10. Ultrasonic impulse response of metal2.

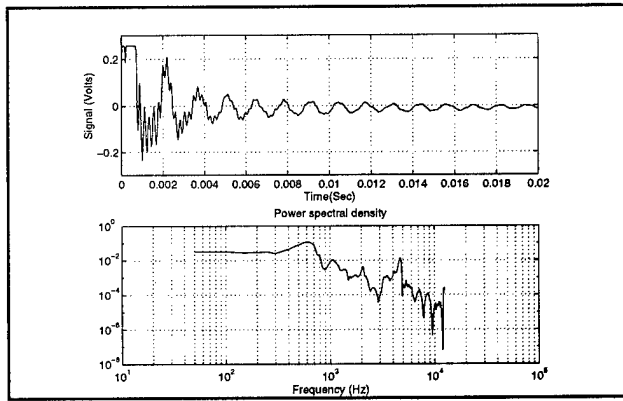


Fig. 8. Impact force response of rock2.

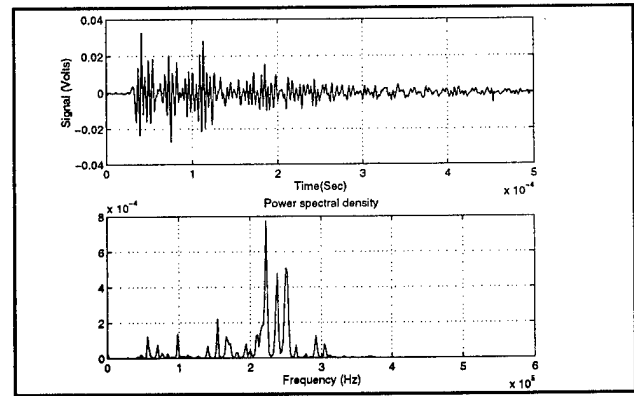


Fig. 11. Ultrasonic impulse response of plastic1.

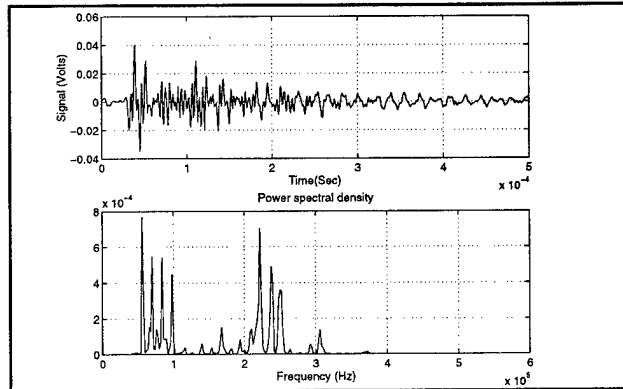


Fig. 9. Ultrasonic impulse response of metal1.

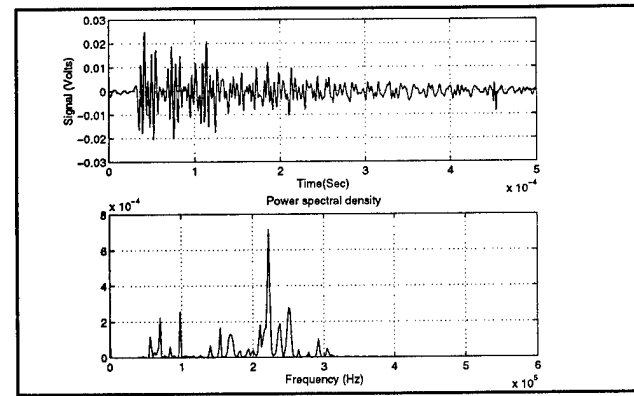


Fig. 12. Ultrasonic impulse response of plastic2.

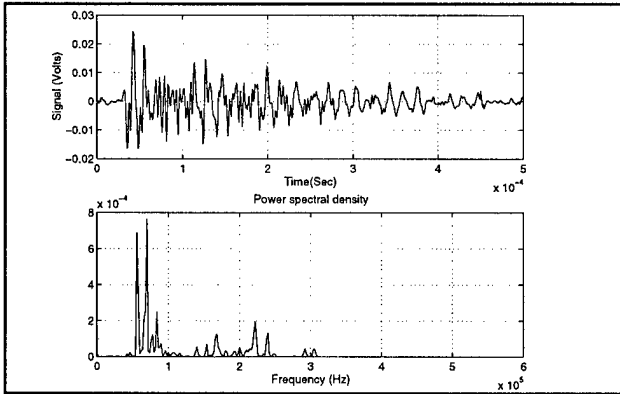


Fig. 13. Ultrasonic impulse response of rock1.

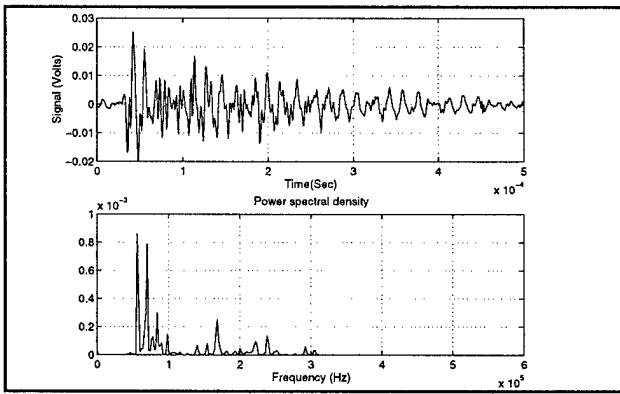


Fig. 14. Ultrasonic impulse response of rock2.



# Advances in the Magnetic Detection and Classification of Sea Mines and Unexploded Ordnance

Ted R. Clem

Coastal Systems Station, Dahlgren Division, Naval Surface Warfare Center, Panama City, FL 32407

**Abstract** – Magnetic sensors offer a complementary approach to active acoustics for shallow water mine reconnaissance and hunting. The U.S. Navy has developed an approach using a 5-channel tensor magnetic gradiometer to provide enhanced classification and localization in mobile operations beyond the capability offered by the commonly used single-channel total field magnetometer. Buried mine detection and low false alarm rates were demonstrated using such a 5-channel gradiometer in fusion with acoustic sensors. This sensor featured bulk and wire niobium low critical temperature (low  $T_c$ ) superconducting components cryocooled by liquid helium. Advances in material research and new concepts are being pursued to enhance opportunities with this 5-channel gradiometer concept: an advanced low  $T_c$  superconducting prototype incorporating all thin film niobium superconducting components to demonstrate increased detection range in the Joint Countermine Advanced Concept Technology Demonstration, a high  $T_c$  superconducting concept using liquid nitrogen refrigeration to reduce package size and cryogenic support requirements, and a room temperature fluxgate prototype for man-portable applications where shorter detection ranges are useful. Recent experimental results using this technology have been obtained to demonstrate an enhanced capability for the detection of unexploded ordnance for environmental cleanup. In this paper, these recent advances in sensor development and the new testing results will be reviewed.

## I. INTRODUCTION

Magnetic sensors have proven merit for mobile area surveys and search operations conducted from air, land or sea including application for the detection, classification, and localization of sea mines, unexploded ordnance (UXO), and chemical, biological and

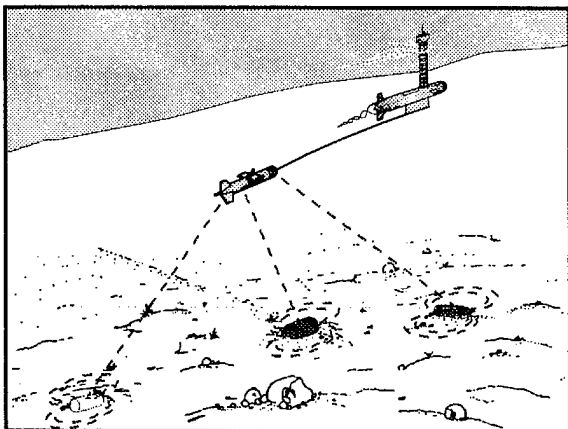
nuclear waste [1]-[4]. In fact, in an assessment conducted by the Jet Propulsion Laboratory for the Army Corps of Engineers, magnetic sensors in general were identified among the most useful sensors for UXO detection and localization, and superconducting gradiometers were specifically identified as the most useful tool in a class by themselves [5]. For applications in sea mine countermeasures, we can envision operational scenarios in which long-range detection is required for reconnaissance and hunting in preparation for an amphibious assault or shorter-range detection is required for diver mine detection and avoidance (Fig. 1).

In Sections I.A and I.B, we shall describe two types of sensors which detect magnetic anomalies: sensors which detect changes in the local magnetic field, *magnetometers*; and sensors which measure the spatial derivatives of magnetic field, (*first order*) *gradiometers*.

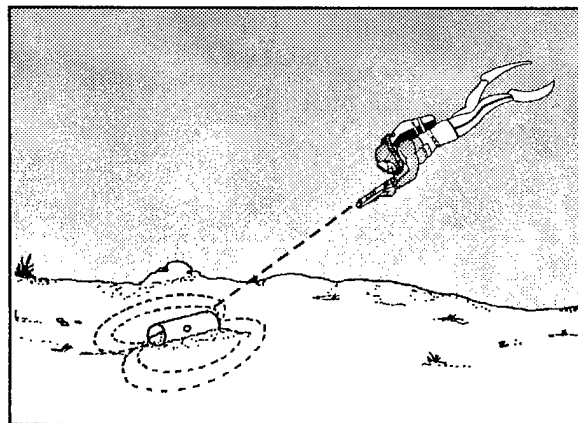
### A. Magnetometers

The performance of a magnetic sensor is measured by its detection range, which is a function of its configuration and sensitivity and the magnetic moments of the targets of interest. In the far field, a target can be well approximated as a magnetic dipole. In this approximation, relatively simple, analytic expressions can be written to relate sensitivity requirements in terms of nominal values for target magnetic moment and range.

For the special case in which a circular, connected conducting loop with area  $A$  is carrying an electrical current  $I$ , we can define the magnetic moment of the loop as the vector  $\mathbf{m} = IA\hat{\mathbf{n}}$  where  $\hat{\mathbf{n}}$  is the normal to the loop in the direction defined by the right-hand rule for positive current. The International System (SI) unit for magnetic



(a)



(b)

Figure 1. Operational scenarios for the magnetic detection and classification in sea mine countermeasures: (a) operation onboard an unmanned underwater towed vehicle towed behind a semi-submersible remotely-operated vehicle for reconnaissance and hunting and (b) diver-portable operation for diver mine detection and mine avoidance.

moment is ampere-meter-squared (A-m<sup>2</sup>). The magnetic induction for a magnetic dipole can be written as

$$\mathbf{B} = \frac{\mu_0}{4\pi} \left[ \frac{3(\mathbf{m} \cdot \mathbf{r})\mathbf{r}}{r^5} - \frac{\mathbf{m}}{r^3} \right] \quad (1)$$

The concept of magnetic moment  $\mathbf{m}$  can be generalized for an arbitrary magnetic body and the magnetic induction of the body will approach the result of (1) in the far field. In air, the magnetic induction  $\mathbf{B}$  is related to the magnetic field  $\mathbf{H}$  via  $\mathbf{B} = \mu_0 \mathbf{H}$ . Hereafter,  $\mathbf{B}$  will be used exclusively and will be referred to as the magnetic field. The following units for magnetic field will frequently be used to represent sensor sensitivities: nanotesla (1 nT = 10<sup>-9</sup> T), picotesla (1 pT = 10<sup>-12</sup> T), and femtoTesla (1 fT = 10<sup>-15</sup> T).

A number of sensors, notably fluxgate magnetometers and superconducting magnetometers, measure the individual vector components of field. A three-axis vector magnetometer, likely using fluxgate or superconducting sensors, is very useful for localization (providing three channels of information). For stationary applications in geophysics and barrier defense, such sensors are effective. However, to date, these sensor types have not proven effective for mobile applications, since means to compensate the anomalous signals arising from rotations in the Earth's magnetic field have not been devised.

Other magnetometers, notably those based on nuclear or atomic resonance processes, measure the magnitude of the total magnetic field and are known as total-field magnetometers. Let  $\mathbf{B}_0$  denote the magnetic field of the Earth, and let  $\mathbf{b}$  denote the induction generated by an anomaly. If  $|\mathbf{b}| \ll |\mathbf{B}_0|$ , then the signal observed by a total field sensor (referenced to the baseline Earth field) is

$$b_m \equiv |\mathbf{B}_0 + \mathbf{b}| - |\mathbf{B}_0| = \sqrt{B_0^2 + 2\mathbf{B}_0 \cdot \mathbf{b} + b^2} - B_0 \approx \frac{\mathbf{B}_0 \cdot \mathbf{b}}{B_0} \quad (2)$$

As a result of the right-hand approximation above, a total-field magnetometer does not simply measure the magnitude of the magnetic-field anomaly, but measures instead the projection of that anomalous signal onto the earth's field.

Total-field magnetometers have provided the generally accepted method for magnetic anomaly detection. In particular, the AN/ASQ-81 and its successor the AN/ASQ-208 are total-field magnetometers utilized by the U.S. Navy for submarine detection from airborne platforms. A major advantage of this type of sensor is its insensitivity to rotation in the Earth's background field of 50,000 nT (since total field is a rotational invariant).

Measurements by total field magnetometers are difficult to interpret because these sensors effectively measure the projection of the anomalous magnetic field vector onto the Earth's magnetic field instead of the total field. Interpretation often requires an experienced operator, and precise anomaly locations are difficult to obtain. Since total field magnetometers provide only one channel of information, they lack valuable target vector information. In particular, they provide very limited localization and little capability for anomaly classification through moment determination. Moreover, these sensors are limited in field operation to sensitivities at levels approaching 0.1 nT as a result of geomagnetic noise, i.e., temporal

variations in the Earth's field, without the use of very sophisticated compensation schemes.

## B. Gradiometers

The gradient of the magnetic field (in standard MKS units of T/m) is a second-order tensor with components given in Ref. 6 by

$$G_{ij} \equiv \frac{\partial B_i}{\partial x_j} = -\frac{3}{r^7} \frac{\mu_0}{4\pi} \{ \mathbf{m} \cdot \mathbf{r} (r_i r_j - r^2 \delta_{ij}) - r^2 (r_i m_j + r_j m_i) \} \quad (3)$$

As a result of Maxwell's equations in free space, only 5 of these 9 tensor elements are independent. For this reason, (first order) gradiometers are typically designed with 5 independent gradient channels, using the minimum number which permits characterization of the local tensor gradient field.

It is feasible to determine the bearing vector and the magnetic-moment vector direction of the dipole by inversion of the gradient equations at a single point only [6]. More recently it has been shown that the addition of gradient rate information at a single point leads to a unique solution for dipole position and moment vector [7].

The contraction of the gradient tensor defined by

$$G \equiv \sqrt{\sum_{i=1}^3 \sum_{j=1}^3 G_{ij} G_{ij}} \quad (4)$$

is a rotational invariant associated with the gradient tensor analogous to the magnitude of the field vector. This quantity may prove very useful for applications in which a gradiometer is subjected to large rotations during the period of measurement, e.g., hand-held operation (in contrast to straight runs onboard stabilized platforms) [6].

An example of one configuration to measure a single-gradient tensor component and a simple configuration to measure 5 independent gradient components are displayed in Figure 2. Each gradient tensor component is measured by a spatially separated loop pair connected in a common-mode rejection configuration. 3 vector magnetometers are included in the 5-channel gradiometer displayed in Figure 2(b) to compensate for the residual magnetometer signals in the gradiometer channels that arise as a result of manufacturing imperfections in the gradiometer loops.

Gradiometers offer the potential to remove many of the limitations associated with magnetometers because the output of a gradiometer is typically produced by twin magnetometers operating in differential mode. In particular, this configuration provides common-mode rejection of the nominal 0.1-nT temporal variations in the Earth's field and of the nominal 1000-nT field changes arising from typical 1 degree sensor rotations while in towed motion.

Gradiometers may be fabricated using many available magnetometer technologies. Available fluxgate and total-field magnetometers can perform at levels approaching 1-10 pT, while superconducting magnetometers utilizing Superconducting Quantum Interference Devices (SQUIDs) can perform at levels on the order of 1-10 fT. The extreme performance available from superconducting magnetometers provides a capability to fabricate gradiometers with high sensitivity having short baselines. The short baseline provides a compact package with extreme coherence between the magnetometers. The coherence is required to maintain

The appearance of trade names in this document does not constitute endorsement by the Department of Defense; the Navy; or the Coastal Systems Station, Dahlgren Division, Naval Surface Warfare Center.

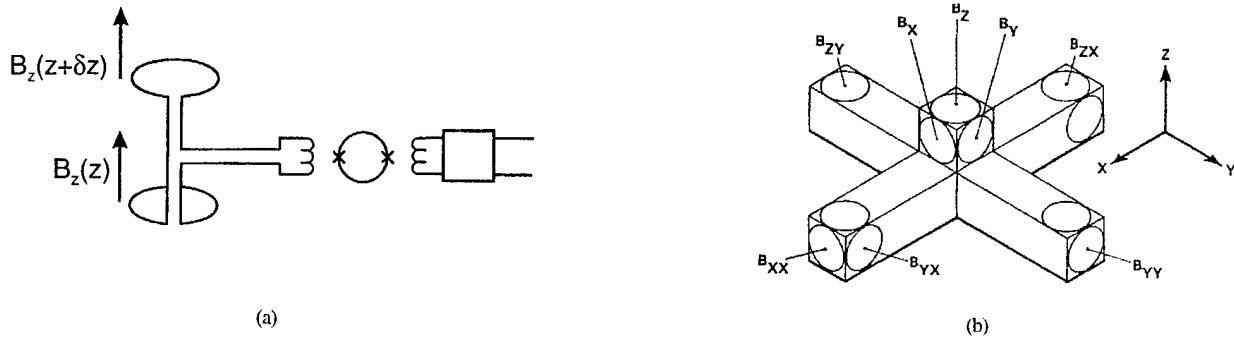


Figure 2. Gradiometer sensor concepts including (a) a single SQUID-based gradiometer channel and (b) a conceptually simple 5-channel gradiometer configuration capable of magnetic dipole localization and moment classification (with 3 orthogonal magnetometers for motion compensation).

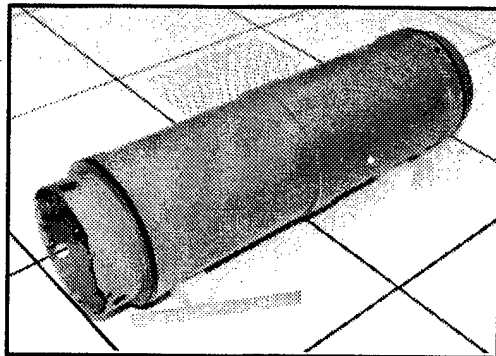
high performance when in motion, and the compact package is amenable to implementation aboard one vehicle. In addition, with the compact sizes, a large number of gradient channels can be integrated into a small package to obtain complete position and moment determination of a magnetic dipole target at a single point in space.

### C. The Superconducting Gradiometer/Magnetometer Sensor

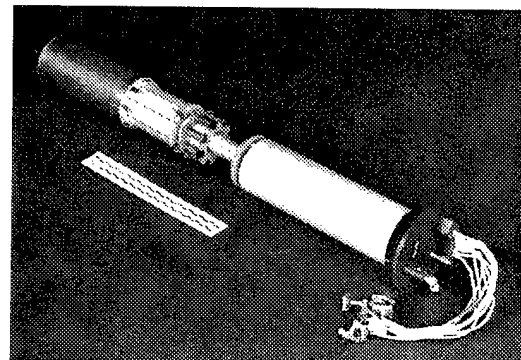
Almost all of the efforts with SQUID-sensor technology have dealt with sensors inside a very controlled laboratory environment, and to a more limited extent outside the laboratory at stationary locations, notably for geophysical measurements. During the 1980's, the Coastal Systems Station (CSS) developed the Superconducting Gradiometer/ Magnetometer Sensor (SGMS) specifically for mobile operations outside the laboratory environment (Fig. 3). The sensor employs largely niobium bulk and wire superconducting technology (with thin-film Josephson Junctions), features dc SQUIDS housed inside superconducting shields, and is convectively cooled to 4 degrees Kelvin by helium gas evaporating from a liquid helium reservoir. Under some field conditions, the SGMS has attained

sensitivities on the order of  $1\text{pT/m-Hz}^{1/2}$  at 0.1 Hz. In comparison total-field gradiometers (with a 0.3-meter baseline) specifically designed for operation onboard a moving platform have achieved sensitivities on the order of  $30\text{pT/m-Hz}^{1/2}$  at 0.1 Hz and a fluxgate gradiometer described in Section VII.A has achieved a sensitivity on the order of  $300\text{pT/m-Hz}^{1/2}$  at 0.1 Hz [1], [2].

The CSS initiated the Magnetic and Acoustic Detection of Mines (MADOM) Project starting in 1985. This project successfully demonstrated the value of magnetic and acoustic sensor fusion for mine reconnaissance and hunting. The SGMS demonstrated, for the first time, high sensitivity and rugged, robust, and reliable performance of a superconducting gradiometer operating outside the laboratory environment onboard a towed underwater vehicle with sea testing conducted for a period of 7 years. Gradiometer operation was automated (with the exception of semi-automated initial tuning) and fully-automated, real-time magnetic detection and classification signal processing was demonstrated to provide effective and accurate moment determination and localization for single and multi-target cases [1], [2].



(a)



(b)

Figure 3. Major subassemblies in the SGMS package: (a) dewar and (b) sensor probe unit.



#### D. Quantitative Comparison of Magnetometers and Gradiometers

The signal strength of a magnetic dipole decreases as the third power of the range for magnetic fields and as the fourth power of the range for magnetic gradients. The approximate ranges of magnetometers and gradiometers are displayed in Figure 4 as functions of dipole strength and sensor sensitivity. It can be shown that the sensitivity requirements for a magnetometer and a gradiometer, respectively, to have the same detection range  $r$  against a given dipole target, is given by the approximate relation  $N_g/N_m \sim 3/r$ . For example, the detection of a mortar shell with a magnetic moment of  $0.1 \text{ A}\cdot\text{m}^2$  at a range of 3 m, requires a magnetometer with sensitivity of  $0.36 \text{ nT}$  or a gradiometer with sensitivity of  $0.36 \text{ nT/m}$  (given a 10-dB signal-to-noise ratio for both cases).

It should be noted that the high rate of signal reduction with the fourth power of distance in the case of a gradiometer represents an apparent shortcoming for a gradiometer configuration. We believe that the ability to develop gradiometers with sensitivity greater than  $1 \times 10^{-3} \text{ nT/m}$  for mobile operations and the extreme difficulty in utilizing magnetometers with sensitivity greater than  $0.1 \text{ nT}$  in mobile operations significantly outweighs this shortcoming. Moreover, the fourth power reduction of detection range with moment for a gradiometer has merit for the detection of targets with relatively small moments. For example, a  $3 \text{ pT/m}$  gradiometer can detect an individual 500-pound bomb (with a moment of  $30 \text{ A}\cdot\text{m}^2$ ) at a range of 33 m and a 60-mm mortar shell (with a moment of  $0.1 \text{ A}\cdot\text{m}^2$ ) at a range of 8 m. Hence there is only a factor of approximately 4 reduction in detection range for a 60-mm mortar

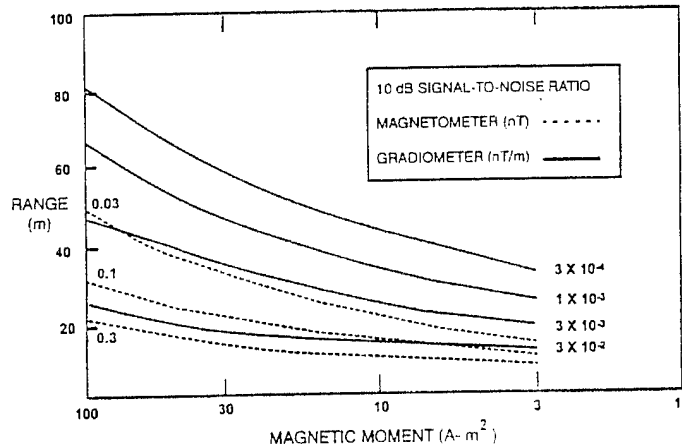


Figure 4. Approximate ranges (in meters) of magnetometers and gradiometers as a function of target strength in terms of magnetic moment (in units of  $\text{A}\cdot\text{m}^2$ ). Curves are given for different sensor sensitivities (in units of  $\text{nT}$  for magnetometers and  $\text{nT/m}$  for gradiometers assuming a 10-dB signal-to-noise ratio in both cases).

shell compared to the 500-pound bomb although there is a factor of 300 in reduction of magnetic moment.

An example of the ease of interpretation for 5-channel gradiometer data compared to single-channel total-field magnetometer data is displayed in Figure 5. Magnetic profiles have been generated for a 60-mm mortar shell buried 1 meter under

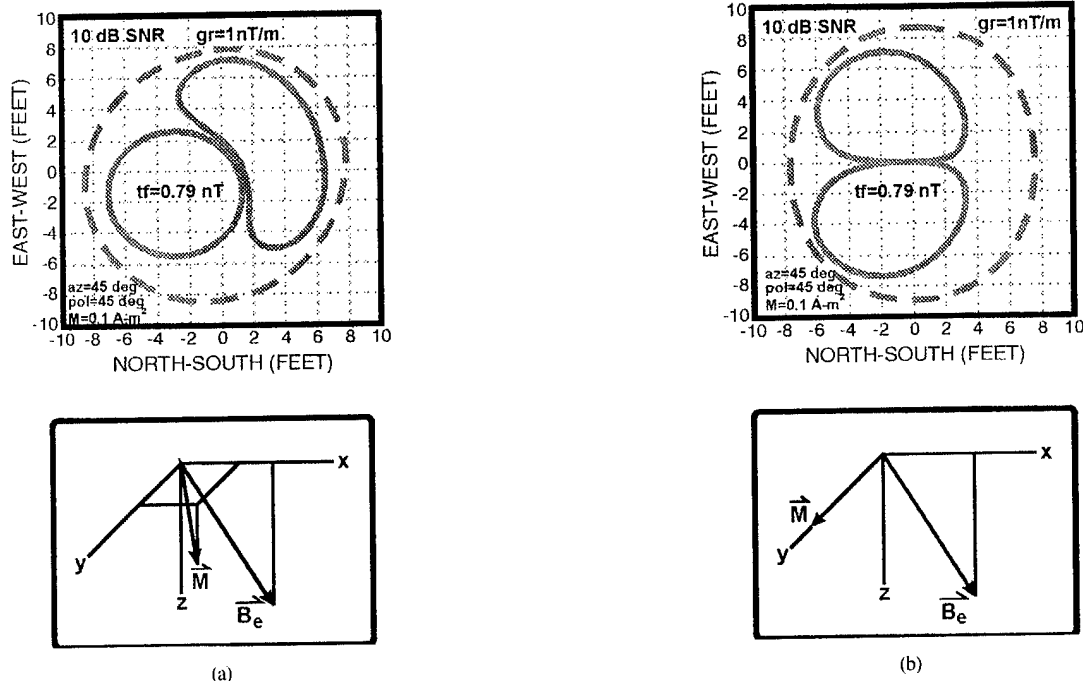


Figure 5. A comparison of magnetometer and gradiometer capabilities for target localization. The profiles measure  $tf$  = total field (Equation (2)) and  $gr$  = gradient magnitude (Equation (4)). Profiles are given for a magnetic dipole centered at origin with (a) a general orientation and (b) orientation in an east-west direction. Observe that the gradiometer profiles are approximately circularly symmetric about the dipole's location so that "gradient" searches normal to the gradient magnitude profiles are meaningful for the gradiometer. In contrast, the magnetometer profiles are not amenable to such straightforward interpretation.

ground for two different orientations with respect to the Earth's background field. In this example, the magnetometer profiles and gradiometer profiles are given by the anomalous total field, Eq. (2), and the corresponding changes in magnitude of the gradient tensor, Eq. (4), respectively. The complex total field profiles require precision data and critical interpretation to localize dipole sources. The symmetric gradiometer profile leads to straightforward interpretation convenient for gradient searches for dipole localization.

## II. SCENARIOS FOR GRADIOMETER MOBILE OPERATION

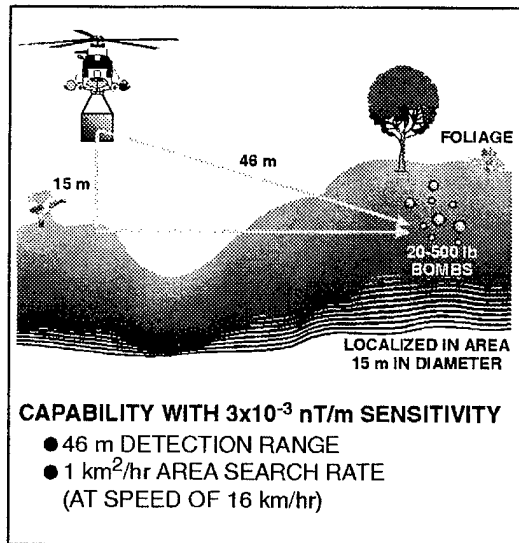
We can envision three general types of operational scenarios: relatively long-range rapid surveys for target clusters, more moderate-range searches against individual targets, and detailed close-in surveys. The selection of magnetic sensor type will largely depend on these operational requirements, determined primarily by the desired detection range, which is, in turn, a function of the magnetic moment of the targets and of sensor sensitivity. The selection also depends on such factors as financial budgets, logistical support and technical expertise of the operators. To date, magnetic sensor approaches have provided limited localization and mapping capabilities. To gain widespread acceptance, approaches must be introduced which provide accurate localization and target classification, and which lend themselves to straightforward interpretation and minimal training. Performance must not be limited by magnetic noise from the host platform and other subsystems. For land-based operations, the system must be capable of operating over rough, overgrown terrain. The sensor and associated signal processing also must deal effectively with environmental noise.

### A. General Considerations

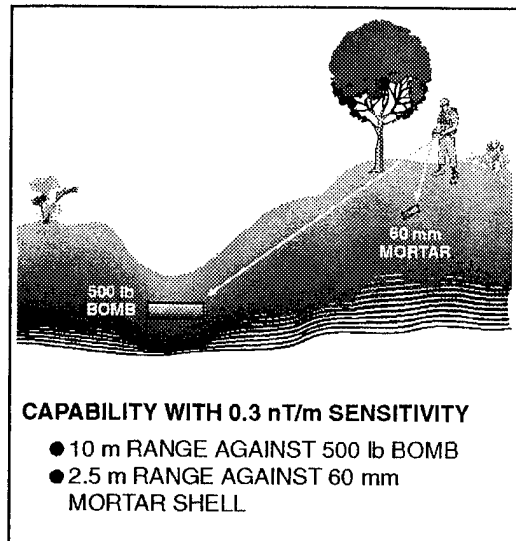
Long-range rapid surveys conducted from an aircraft have been proposed for initial surveys to locate clusters of UXO targets [4]. The mine reconnaissance/hunting demonstration of MADOM represents an example of a moderate-range search. Land-based manual surveys or diver operations for mine detection or avoidance provide examples of close-in surveys. High sensitivity will be critical for the long-range and moderate-range scenarios, but such sensitivity will likely be sacrificed for the close-in surveys at ground level. In fact, local geologic noise limits a gradiometer's noise floor to levels on the order of 0.05 up to 10 nT/m-Hz<sup>1/2</sup> which may limit the use of high-sensitivity gradiometers such as the SGMS for some land-based operations.

A perspective on the role of higher sensitivity gradiometers used for wide-area searches and lower sensitivity gradiometers for close-in surveys can be obtained from the following example (Fig. 6). A 3 pT/m gradiometer can detect a grouping of twenty 500-pound bombs (clustered in a circle several meters in diameter) at a range of 46 meters. An area search rate of 1 km<sup>2</sup>/hr can be obtained when the sensor's altitude is 15 meters moving at a forward speed of 15 km/hr. When deployed from the ground, a less sensitive 300 pT/m gradiometer would provide detection ranges of 10 meters and 3 meters for the detection of a 500-pound bomb and a 60-mm mortar shell, respectively.

Two fundamental approaches for operation of a 5-channel tensor gradiometer stand out. First it will often be convenient to conduct straight-line searches at constant velocity for airborne and underwater vehicle operation and also for some land-based surveys if the terrain admits straight-line trajectories. For other cases,



(a)



(b)

Figure 6. Two modes of operation for 5-gradient channel sensors: (a) wide-area surveys using high sensitivity sensors and (b) short-range searches for single targets using less sensitive sensors.

including many man-portable land-based and diver operations, it will be unreasonable to expect controlled operator motions along straight-line trajectories at constant velocities. In either case, we can implement signal processing using point-by-point inversion of the motion-compensated gradiometer signals. For the special case of straight-line searches, we can also utilize least-squares fit to the time series in order to improve target detection. One approach using point-by-point inversion is described in Section II.B and one approach using a least-squares fit is described in Section II.C below.

### B. Localization using Point-by-Point Signal Inversion

As mentioned above, the five independent gradient tensor components at a single point can be used to construct the bearing vector to a dipole source, and a scaled moment vector with the same direction as the dipole moment vector and a magnitude given by  $m/r^4$  [6]. The difficulty with this inversion is that there are multiple solutions: two nontrivially related solutions in a given half space, and two additional solutions obtained by reflection of the first two through an origin centered on the gradiometer. This multiplicity of solutions has limited the practical application of this algorithm. More recently, Wynn [7] has investigated the use of the rate of change of the gradient tensor components, and their role in resolving the scaling and uniqueness issues associated with the gradient tensor inversion.

For a sensor with specified translational velocity  $\mathbf{v}$ , the time rate of change of the gradient tensor components has the form

$$\dot{G}_{ij} = \frac{3\mu_0}{4\pi r^9} \{ 35(\mathbf{m} \cdot \mathbf{r})(\mathbf{v} \cdot \mathbf{r})r_i r_j - 5r^2[(\mathbf{m} \cdot \mathbf{v})r_i r_j + (\mathbf{m} \cdot \mathbf{r})(v_i r_j + v_j r_i) + (\mathbf{v} \cdot \mathbf{r})(m_i r_j + m_j r_i) + (\mathbf{m} \cdot \mathbf{r})(\mathbf{v} \cdot \mathbf{r})\delta_{ij}] + r^4[m_i v_j + m_j v_i + (\mathbf{m} \cdot \mathbf{v})\delta_{ij}] \} \quad (5)$$

These equations have been inverted to give multiple solutions for the bearing vector and a scaled moment vector in the direction of the dipole moment vector with a magnitude  $g$  given by  $m/r^5$ . The solution for bearing vector and moment vector direction common to the two inversions is unique, and the different scaling for the scaled moments in the two inversions yields the range to the dipole, resulting in a unique solution for  $\mathbf{m}$  and  $\mathbf{r}$  on a point-by-point basis. In practice, it is not necessary to specify a sensor velocity. All that is needed is knowledge of the position of the gradiometer relative to the Earth's reference frame. Work is ongoing to apply these algorithms to the practical interactive localization of buried UXO by means of a man-portable tensor gradiometer.

### C. Localization using a Time-Series Least-Squares Fit

A mathematical model for detection, classification, and localization (D/C/L) of multiple stationary magnetic dipole targets using a gradiometer (with 5 independent tensor gradiometer channels appropriately selected and 3 orthogonal magnetometer channels) moving in a straight line trajectory past the targets at a constant speed has been developed and validated in the MADOM project. The 5 output signals  $S_i(t)$  ( $i=1,2,\dots,5$ ) from the 5 independent gradiometer channels and the 3 magnetic field components  $B_l(t)$  ( $l=1,2,3$ ) are measured as a function of time as the sensor moves past the targets. The time derivatives of field  $dB_l(t)/dt$  are calculated from the  $B_l(t)$  for eddy-current compensation. The

objective of this model is to extract the dipole signals  $G_{ij}^{(k)}(t)$  ( $k=1,2,\dots,n$ ) for the unknown number  $n$  of dipole targets and then to determine the magnetic moments and the positions of the  $n$  targets.

The model describes the signals  $S_i$  in the 5 gradiometer channels by the equations

$$S_i(t) = \sum_{j=1}^5 c_{ij} \left\{ \sum_{k=1}^n G_{ij}^{(k)}(t) \right\} + \alpha_i + \sum_{l=1}^3 \beta_{il} B_l(t) + \sum_{l=1}^3 \gamma_{il} \dot{B}_l(t) + v_i(t) \quad (6)$$

where  $c$  is the pre-determined calibration matrix for the gradiometer.  $v_i(t)$  and  $\alpha_i$  are uncompensated noise (setting the noise floor of the channel compensation parameters per channel) and channel biases, respectively, and  $\beta_{il}$  and  $\gamma_{il}$  are the balance and eddy-current vectors for channel  $i$ . An iterative analysis first estimates the  $\alpha$ 's,  $\beta$ 's and  $\gamma$ 's (a total of 35 parameters) and then executes a gradient search for the location of the single target that best fits the residual signal. The  $\alpha$ 's,  $\beta$ 's and  $\gamma$ 's, and target location and moment are then optimized, and the procedure is repeated for a second target. Targets continue to be added until finally no target can be found whose signal contributes substantially to a reduction in total signal power, at which point the algorithm terminates.

Fig. 7 displays the motion-compensated signals obtained from the gradiometer and the information extracted from the algorithm in detecting a 1000-lb Mk83 bomb. The five gradiometer signals are displayed for a 45-m section of data with the bomb located 15 m to port and 5 m below the gradiometer at the closest point of approach. The measured and predicted target location, moment, and orientation are also displayed to indicate the capability of the algorithm to provide good fits to the data.

## III. MOBILE UNDERWATER DEBRIS SURVEY SYSTEM

A project has been initiated to develop and evaluate a Mobile Underwater Debris Survey System (MUDSS) capable of finding and accurately mapping the locations of UXO ranging from small shells to large bombs in water depths of from 4 to approximately 100 feet in coastal regions at formally used defense sites [3]. The effort involves a collaboration between CSS and the Jet Propulsion

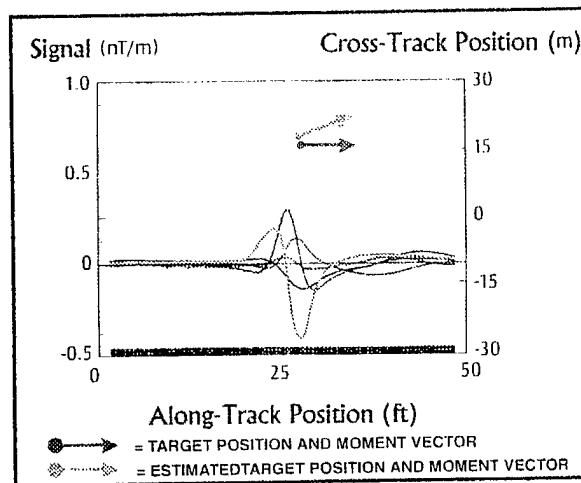
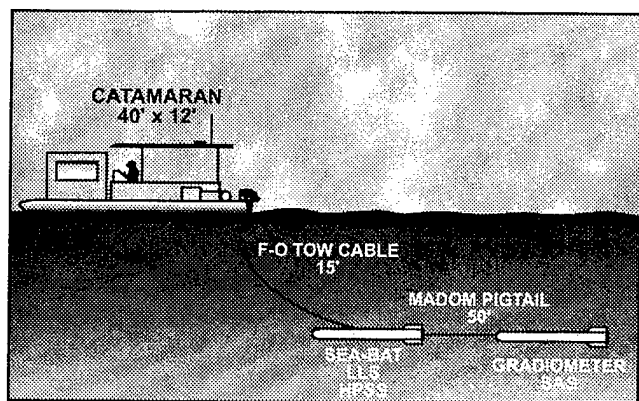
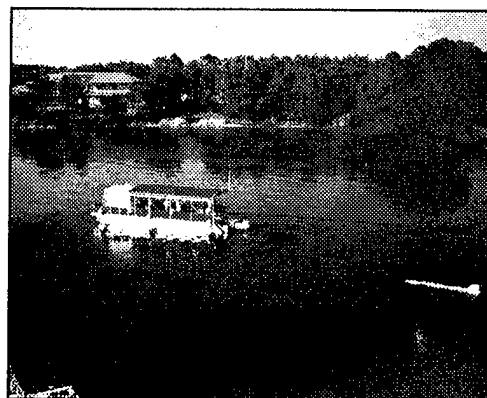


Figure 7. The five gradiometer signals in a 45-m section of data on a pass near a Mk83 1000-lb bomb.



(a)



(b)

Figure 8. The Mobile Underwater Debris Survey System: (a) artist's concept detailing key features of the system and (b) photograph of system in transit to test site with the dead-weight depressor housed out of water for speed and maneuverability.

Laboratory [8]. In addition to the application of UXO detection at coastal sites utilizing underwater towed sensor suites as described in this section, the use of a superconducting gradiometer in a system concept for rapid airborne reconnaissance and survey of UXO sites has been proposed [4].

#### A. General Project Description

The MUDSS project is divided into two phases. Phase I, which ran for one year and culminated in an at-sea feasibility demonstration of a multi-sensor MUDSS prototype against UXO in a drill target field. The feasibility demonstration was successfully executed in August and September of 1995 in St. Andrews Bay (near Panama City, FL) with the SGMS utilized for magnetic detection. Phase II will culminate in 1997 in a technology demonstration consisting of a UXO survey at a yet-to-be-determined formally used defense site.

Figure 8 depicts the first version of the MUDSS system which was fielded in 1995 for the feasibility demonstration. The surface craft is a custom designed, magnetically and acoustically quiet, shallow draft, trailerable catamaran. A dead-weight depressor is suspended off of the back of the catamaran to maintain the appropriate depth for sensor operation and to house part of the sensor suite (a RESON Seabat ahead looking sonar, a CSS-developed high frequency sidescan sonar, and a Raytheon-leased LS 4096 laser linescanning electro-optic sensor). A second neutrally buoyant tow body trailing the deadweight depressor houses a CSS-developed low frequency synthetic aperture sonar and the SGMS.

Reference 3 gives a detailed description of the feasibility demonstration test field layout, the testing procedures, and the performance of the acoustic and electro-optic sensors. Specific details relevant to the gradiometer demonstration are given here.

#### B. Gradiometer Results from the Feasibility Demonstration

A linear target field was laid out to evaluate the SGMS performance. The field consisted of a row 200 m in length of eight small and medium-sized targets (mortar and artillery shells ranging in caliber from 60 up to 203 mm) running north-south; a second, shorter row of three medium-sized targets (two oil drums and a Mk82 500-lb bomb) parallel to, and 9 m east of, the first row; and a third row of two targets (a Mk83 1000-lb bomb and a Mk84 2000-lb bomb) 9 m east of the second row. A marker and a sonar calibration panel with ferrous anchors were laid at one end of the linear field. Estimates of the magnetic moments for the targets obtained from the D/C/L algorithm described in Section II.C are tabulated in Table I. These magnetic moments ranged from 0.03 A-m<sup>2</sup> for one 60mm mortar shell up to 120 A-m<sup>2</sup> for the 2000-lb bomb.

TABLE I  
ESTIMATES OF MAGNETIC MOMENT FOR THE UXO TARGETS

Target	Moment (A-m <sup>2</sup> )	Range (m)	Relative Range
60mm shell	0.03 - 0.2	6 - 9	1-1.5
81mm shell	0.3	10	1.6
105mm shell	0.7	13	2.2
175mm shell	3	18	3
203mm shell	5	22	3.6
55 gal oil drum	10 - 25	27 - 32	4.5 - 5.3
500-lb bomb	20	30	5
1000-lb bomb	40	36	6
2000-lb bomb	120	48	8

The detection range for these targets is also tabulated in Table I. Absolute range is given for a gradiometer with sensitivity of 3

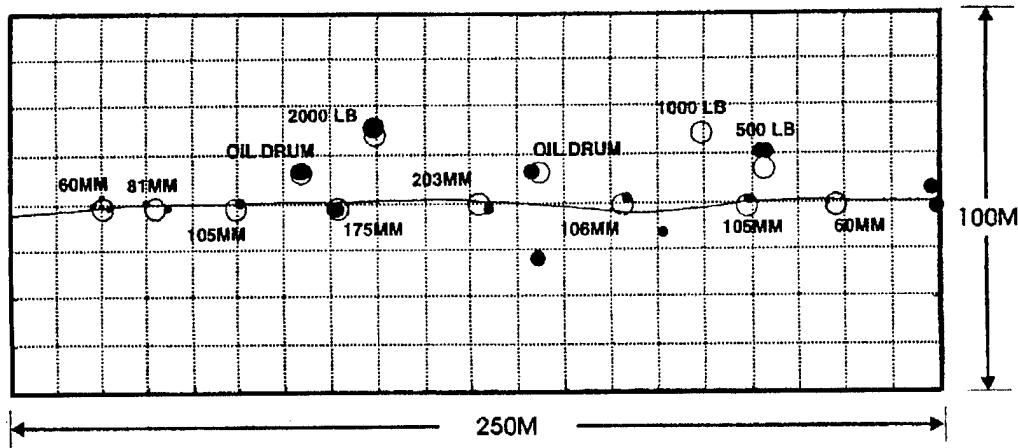


Figure 9. Gradiometer targets found in one run over the linear field with the open circles  $\circ$  indicating the actual target locations and the solid circles  $\bullet$  indicating the positions predicted by the D/C/L algorithm. The size of the solid circles  $\bullet$  indicates the predicted magnitude of the target's magnetic moment.

$\text{pT/m-Hz}^{1/2}$  at 0.1 Hz assuming a 10 dB signal-to-noise ratio and relative range is given for fixed gradient sensitivity (normalized to 1 for a 60mm shell with magnetic moment of  $0.03 \text{ A}\cdot\text{m}^2$ ). Observe that the 2000-lb bomb is detectable at 8 times the range of the 60mm mortar shell.

The predicted results from the D/C/L algorithm to estimate location and to classify the targets according to magnetic moment are displayed in Fig. 9 for one pass of the system through the target field. Open circles designate the actual location of the targets, while the solid circles indicate the predicted positions. The size of the solid circles indicate the magnitude of the targets' magnetic moment. For the feasibility demonstration, the nominal performance of the gradiometer channels was on the order of  $3 \text{ pT/m-Hz}^{1/2}$  at 0.1 Hz. The D/C/L algorithm was effective in localization and classification (by moment magnitude) all of the targets in this pass with the exception of the 1000-lb Mk83 bomb. This exception provides an example of multi-target localization in which there are 2 targets (the 500-lb bomb and the 105mm shell) in this data window in addition to the 1000-lb bomb. In this case, the algorithm successfully localized the 500-lb bomb and the 105mm shell with high signal strength, but failed to locate the more distant 1000-lb bomb with a relatively weak signal strength. The ferrous anchors for the marker and calibration panel at the right hand side of the map and two clutter objects in proximity to the 106mm shell (not a part of the target set) were also detected during this run. Double detections are displayed in Figure 9 for two targets, the 500-lb bomb and one of the two oil drums. These represent target detections by the D/C/L algorithm in two separate data segments. The high degree of overlap for the double detections is suggestive of the degree of accuracy obtained with this algorithm.

#### IV. CLUTTER REJECTION

Generally active acoustic approaches have proven to be an effective means to detect, classify and localize tethered sea mines or bottom mines proud with respect to the bottom in deeper waters. However the shallow-water bottom mine environment is an especially difficult acoustic environment in which to operate. Interfering reverberations from the air/sea and sea/bottom interfaces, bottom topographical features, general harbor debris, and mine burial present a difficult acoustic environment for bottom mine detection. In coastal regions, the density of debris clutter may lead

to a high false-alarm rate using conventional imaging sonar approaches alone.

For effective clutter rejection, it is very desirable to use distinctly different sensor approaches. The application of two or more collocated sensors operating simultaneously has the potential to reduce false alarms and provide robust detection in a wide variety of background conditions. For mine reconnaissance and hunting, the combination of magnetic sensors with sonars provides such an alternative. In the MADOM sea testing, more than 90% of the acoustically mine-like clutter was not magnetically mine-like.

Several investigations have been conducted recently using automated neural network approaches to assess the merit of magnetic and acoustic data fusion [9], [10]. The following result was obtained courtesy of L. Smedley and G. Dobeck [10]. A set, consisting of 215 sonar images containing an assortment of drill targets and clutter objects, was assembled using data collected from sea tests with the SGMS and the MADOM low frequency synthetic aperture sonar. For each sonar image, the magnetic detections were co-registered. An attractor-based k-nearest neighbor neural network was developed using the magnetic and acoustic features given in Table II.

TABLE II  
FEATURES USED TO TRAIN THE NEURAL NETWORK DEVELOPED IN [10]

Magnetic Features	Acoustic Features
Total magnetic moment	Average signal-to-noise ratio (SNR) over object's length
Y-component of moment	Average SNR over object's width
Z-component of moment	Maximum of the ratio of SNR for length to SNR for width
Depth estimate	Number of intense pixels
Confidence level for correct object classification and localization	Target length
	Target width
	Estimated clutter density

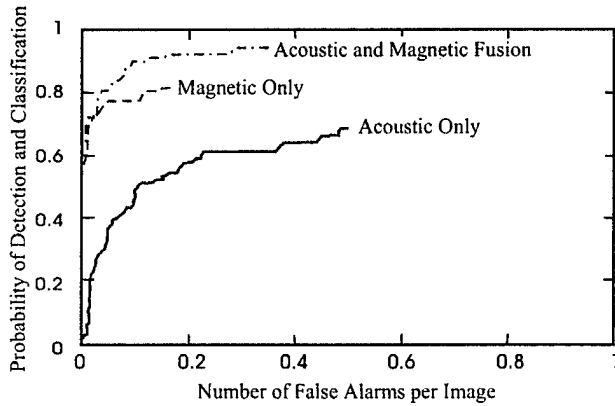


Figure 10. The probability of detection and classification for acoustic and magnetic sensors alone and for neural-network fusion data from both sensors given as a function of the number of false alarms per image in the two tracks from 10 to 27 meters on either side of the vehicle.

Receiver operating curves (ROCs) for this data were established for different detection ranges, recognizing the fact that the two sensors are effective over different ranges. The ROC for the individual sensors and for the two-sensor data fusion (obtained from this neural network) are displayed in Fig. 10 for tracks on both sides of the vehicle in a range where both sensors were effective. For these tracks, there were 93 drill targets in the 215 images.

We observe in this figure the improved detection and classification obtained using the data fusion. For an acceptable rate of 0.1 false alarms per image, the probability of detection and classification was 0.5 for the acoustic sensor alone and 0.77 for the magnetic sensor alone. The probability of detection and classification increased to 0.9 for a rate of 0.1 false alarms per image using this neural-network data fusion. Although these results were taken from a small data set of 215 images, we believe that the trend clearly demonstrates the substantial benefit of magnetic and acoustic data fusion for shallow water mine reconnaissance and UXO survey.

## V. THE THIN-FILM GRADIOMETER

We believe that the current technology, represented by the SGMS sensor, is reaching its performance limit. This technology is largely characterized by the use of bulk and wire niobium (Nb) superconducting components. Advances in Nb thin film technology to obtain increased low frequency sensitivity and the relative simplicity of the thin-film processing in contrast to labor-intensive assembly of bulk SQUID packages and the hand winding of wire loops are appealing. For mobile applications, the greater intrinsic balance, i.e., common-mode rejection of the Earth's magnetic field, obtained from thin-film lithography compared to manual winding of wire loops and the removal of bulk magnetic components, including superconducting diamagnetic components such as shield canisters, is important to reduce anomalous signals in the gradiometer sense loops arising from acceleration-induced relative motion of parts. A project to develop a high sensitivity, all thin-film gradiometer sensor for mobile deployment is being pursued by the CSS, IBM Research [11], Ball Aerospace [12], Lockheed-Martin [13], Quantum Magnetics [14], and the Naval Research Laboratory [15] for

demonstration in the Joint Countermine Advanced Concept Technology Demonstration.

### A. Cryogenic and Room-Temperature Electronics

Major advances in Nb thin-film fabrication technology has led to the development, for the first time, of high quality low frequency SQUID-based magnetic sensors utilizing Nb-AlO<sub>x</sub>-Nb tri-layer technology on a 5" scale. This work has led to the production of totally unshielded gradiometers which have been successfully demonstrated to operate in the Earth's magnetic field.

A cryogenic probe assembly for high performance in mobile operation has been manufactured with 3 tensor gradiometer circuits mounted on a single-crystal silicon rod and mounted to the dewar neck plug (Fig. 11). The gradiometer circuits consist of 2 counterwound magnetometer loops, each 3.8 cm square with a baseline of 5.3 cm, monolithically coupled to the SQUID. The precision lithography in conjunction with a configuration in which the sense loops, the SQUID washers, and their modulation and feedback coils are all patterned as gradiometers has provided extreme balance in order to maintain full sensitivity in the presence of field changes on the order of 1000 nT.

A benchtop version of high frequency flux-lock loop (FLL) feedback electronics with a modulation frequency of 16 MHz, a factor of 15 to 30 times the current frequency available with commercial electronics, has been developed in order to assure specified signal-to-noise ratios required from the all thin-film gradiometer channels (using air-core thin-film output transformers in place of wire-wound ferrous-core transformers) and to provide a high bandwidth for electromagnetic interference immunity [16].

### B. The Advanced Liquid Helium Dewar

A dewar prototype, referred to as the Advanced Liquid Helium Dewar, was developed to assure that the dewar would not limit sensor performance (Fig. 12). A flexible design approach supported by detailed thermal, mechanical and field calculations was pursued. Stringent material selection and magnetic screening standards were established. The materials typically were chosen to be as magnetically clean as possible, with residual magnetizations 10 orders of magnitude smaller than that for soft steel. The magnetic

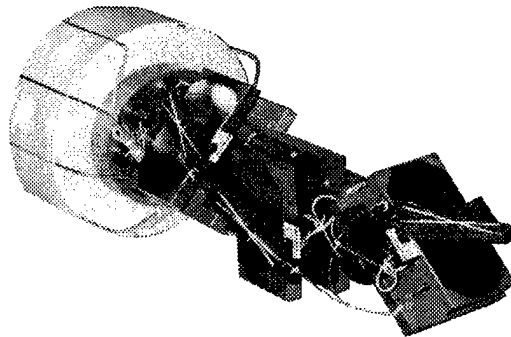


Figure 11. The TFG Cryogenic Probe Assembly.

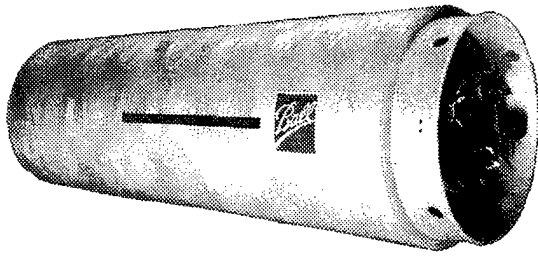


Figure 12. The Advanced Liquid Helium Dewar.

gradient stability and the eddy current stability are 100 times better than the preceding state-of-the-art established with the SGMS.

An exchange gas cooling approach was pursued in place of the convective cooling utilized in the SGMS dewar. New innovations for thermal management have been implemented - anti-slosh baffles, thermal filters to isolate sensor area from bath temperature fluctuations, aluminized-mylar blankets for radiation shielding custom etched to reduce the eddy currents, and thermal networks of 99.999% pure aluminum wire for temperature uniformity. Temperature stability in motions typical of tow operations is on the order of  $1 \mu\text{K}/\text{Hz}^{1/2}$  at 0.1 Hz, a factor three orders of magnitude better than for the SGMS dewar [17].

### C. Field Testing of the Integrated Sensor

The integrated sensor prototype has been evaluated recently under field conditions. For this testing, the benchtop room temperature FLL electronics (which have a significant magnetic signature) are operated off a 15-m cable outside the test facility (remotely positioned some 13 m away from the sensor so as not to limit the performance of the sensor in motion). Stationary measurements have been conducted in this test setup in order to establish a baseline for the motion testing; i.e., to quantify any deterioration of performance in motion. In this configuration for the sensor, white noise on the order of  $50 \text{ fT}/\text{m}\cdot\text{Hz}^{1/2}$  ( $10 \mu\Phi_0/\text{Hz}^{1/2}$ ) has been demonstrated. The knee for  $1/f$  noise occurred at approximately 1 Hz and the noise floor rose to approximately  $200 \text{ fT}/\text{m}\cdot\text{Hz}^{1/2}$  ( $40 \mu\Phi_0/\text{Hz}^{1/2}$ ) at 0.1 Hz. The nominal balance of the gradiometers is estimated at  $1 \times 10^{-4}/\text{m}$  (as measured indirectly from a comparison of compensated and uncompensated motion spectra obtained in preliminary motion testing), a factor of at least 20 greater than obtained with the wire-wound SGMS loops without the trimming procedures required for wire loops. The dynamic range of the gradiometers is  $6 \times 10^6$ .

For comparison, these electronics evaluated in a laboratory environment (integrated with a preliminary version of the gradiometer circuit currently being evaluated) operating off a 2-m cable has white noise on the order of  $4 \mu\Phi_0/\text{Hz}^{1/2}$  with about 1/3 of the noise from the preamplifier. The knee for  $1/f$  noise also occurred at approximately 1 Hz and the noise floor rose to approximately  $7 \mu\Phi_0/\text{Hz}^{1/2}$  at 0.1 Hz. The electronics demonstrated a very high closed loop bandwidth exceeding 2.5 MHz and a very

high slew rate greater than  $1 \times 10^6 \Phi_0/\text{sec}$  at frequencies up to 1 MHz [16]. In comparison, the SGMS has a bandwidth of 100 kHz and a slew rate of  $2.5 \times 10^4 \Phi_0/\text{sec}$ .

### D. Development of a Field-Deployable TFG

The existing TFG is being upgraded to a ruggedized field-deployable version. A fully-populated 5-channel cryogenic probe assembly is being developed to replace the 3-channel laboratory unit. A compact field-deployable room-temperature electronics package is being developed to replace the benchtop FLL electronics currently utilized for the laboratory version and to provide automated sensor control, signal digitization, and data linking. Miniaturization of the electronics into a single integrated unit mounted onto the sensor (as required to obtain sensitivity of the integrated sensor in motion) represents a major undertaking. The entire analog and digital electronics for 5 gradiometer and 3 magnetometer channels is being packaged into a unit 43 cm in diameter and 56 cm in length. The package must have magnetic signature consistent with the sensitivity requirements in motion, power reduced by a factor of 30 compared to the laboratory prototype, and dimensions to minimize the length of the sensor body section for underwater deployment as much as possible. Production is in progress with final assembly and testing to be completed in 1997 for integration in an underwater tow system for mine hunting, specifically for demonstration in the Joint Countermine Advanced Concept Technology Demonstration, and for UXO surveys.

## VI. HIGH $T_c$ SUPERCONDUCTING TECHNOLOGY

As a result of nitrogen cooling, the development of sensors utilizing the high- $T_c$  materials with nitrogen cooling provides an opportunity for significant size reduction, an ease of maintainability and convenience in comparison to the low- $T_c$  technology with helium cooling, factors critical to gain widespread acceptance of the superconducting technology over other magnetic sensor approaches.

### A. Perspective on Nitrogen Cooling for Naval Operations

A broad-based assessment of refrigeration technology including liquid, solid, and triple-point nitrogen dewars and active cryocoolers was conducted [1], [18]. The conclusion from this assessment is that liquid nitrogen dewars represent the best choice for near-term development of a high performance high  $T_c$  superconducting gradiometer for mobile applications. The design for an open (vented) liquid nitrogen dewar with dimensions 45 to 75 cm in length and 30 to 50 cm in diameter has been established consistent with sensitivity goals (Fig. 13). These dimensions are consistent with available space in underwater tow bodies of interest for U.S. Navy applications. A final choice for dimensions in any final dewar design would be based on a tradeoff between space and hold time. Results of the concept analysis indicate that a dewar with dimensions of 43 cm in diameter and 75 cm in length would have a hold time of approximately 33 days. This hold time is over 6 times greater than the hold time for the Advanced Liquid Helium Dewar which has the same diameter but is 150 cm long, twice the length of the nitrogen dewar.

The benefits for naval mobile applications which can be obtained from these reduced cryogen requirements include: (1) a significant reduction in down time during operations; (2) affiliated reductions or

### C. 3-Axis High $T_c$ Magnetometer for Stationary Applications

A 3-axis magnetometer prototype developed by Conductus under a SBIR contract has been evaluated (Fig. 14). This sensor is being developed for stationary operation with a focus on geophysical applications. Results obtained to date are very promising. The sensor has been operated in the field totally unshielded without any deteriorated performance compared to its performance shielded. Magnetometer performance of  $140 \text{ fT/Hz}^{1/2}$  at 1 Hz has been demonstrated under stationary field conditions. This performance is a factor over 50 times better than the performance obtained from the best commercial fluxgate magnetometers. The 3 High- $T_c$  SQUID magnetometer circuits in this unit have been working reliably for over one year without failure [25].

### VII. THE THREE-SENSOR GRADIOMETER

One advantage of the niobium-based superconducting technology, especially for mobile operation, is the ability to fabricate large scale counter-wound gradiometer sense loops using either niobium wire or multi-layer thin films with crossovers. This allows signal subtraction using very low-noise passive circuits prior to signal processing with active amplifier circuits, which greatly reduces dynamic range requirements from the active electronics. A gradiometer can be configured using two independent magnetometers with signal subtraction performed at the output of the two magnetometers. The CSS pursued this approach in the early 1970's using fluxgate technology. Good stationary performance was obtained at that time, but there was insufficient dynamic range in the processing of the differential signals to operate the sensor in motion.

In order to circumvent this dynamic-range limitation arising by differencing two individual magnetometer signals during mobile operation, a novel approach patented by IBM Research is being pursued [26], [27]. A third magnetometer is used for common mode rejection, feeding back a signal to the two primary magnetometers which nulls out the ambient background field. This concept is denoted as the three-sensor gradiometer (TSG). The concept is depicted in Fig. 15 for one case in which there are two

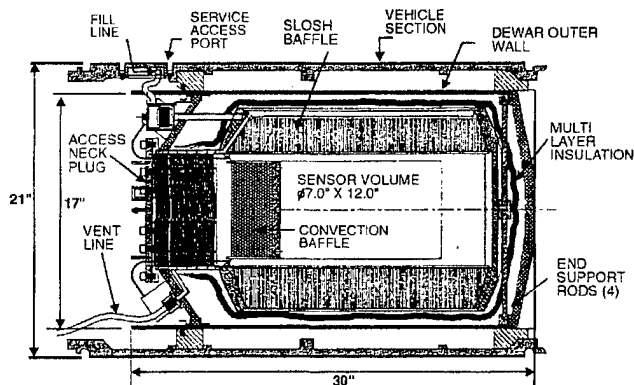


Fig. 13. Liquid nitrogen dewar concept with design versatile for multiple applications. This dewar has an outer diameter of 43 cm (17") (compatible with operation in a 53-cm (21") vehicle) and a length of 75 cm (30"). The dewar is projected to have a hold time of 33 days.

elimination in labor requirements for cryogen support during critical phases of an operation; (3) reduced failures in the cryogenic circuits or in the dewar (such failures typically occur during cryogen recycling); and (4) the elimination of an additional footprint on ship deck required for helium storage. In addition, the use of liquid nitrogen in place of liquid helium significantly reduces supply logistics as a result of the wide availability of nitrogen on the market at domestic and most foreign ports and the availability of a large number of liquifiers in the U.S. Fleet, with at least 54 units identified. Significant cost savings are expected from reduced costs for cryogen supply.

### B. Device Development under this Project

Since 1993, there have been a number of laboratory results reported on magnetometer prototypes with white noise better than  $200 \text{ fT/Hz}^{1/2}$ . A number of test samples, magnetometer circuits and gradiometer circuits have been developed in conjunction with this project. This included a report of  $26 \text{ fT/Hz}^{1/2}$  at 1 Hz for a 2x2-cm magnetometer [19]. As an element of this program, the impact of flux trapping for unshielded operation of high  $T_c$  sensors in the Earth's magnetic field has been investigated and identified to be more problematic than for the corresponding low  $T_c$  niobium thin-film sensors. Approaches are being pursued to circumvent current limitations in high  $T_c$  fabrication technology [20]-[24]. In particular, the three-sensor gradiometer approach described in Section VII.B is an example of one means to circumvent these limitations. In that approach, magnetic-field coils are utilized to null out the Earth's magnetic field at the sensing circuit. The field nulling significantly reduces noise associated with non-ideal magnetization effects in the high- $T_c$  superconducting material.

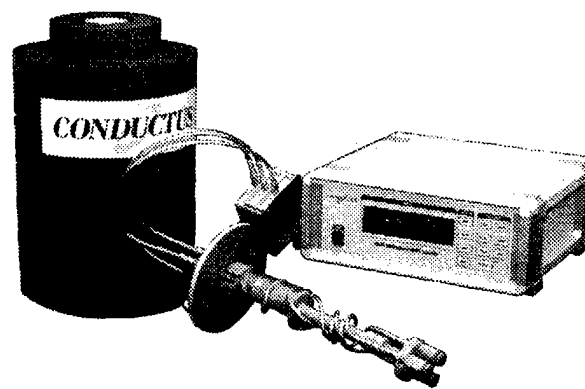


Figure 14. 3-channel high- $T_c$  magnetometer.



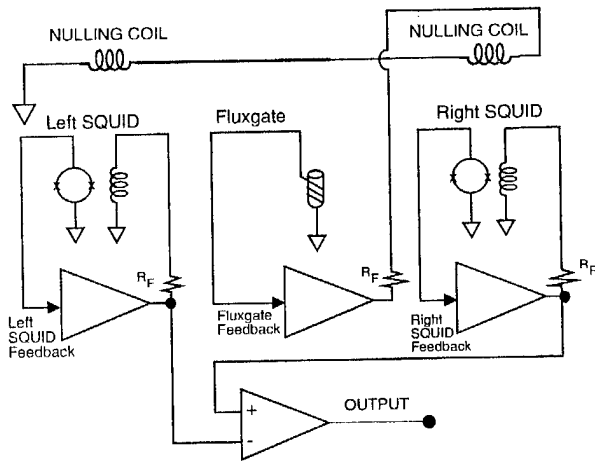


Figure 15. The three-sensor gradiometer concept for one case in which there are two primary high  $T_c$  SQUID-based magnetometers and a third fluxgate magnetometer for field nulling.

primary high  $T_c$  SQUID-based magnetometers and a third fluxgate magnetometer for field nulling.

#### A. The Fluxgate Version of the TSG

The basic TSG concept has been successfully pursued using room temperature fluxgate magnetometers (in place of the SQUID magnetometers). A laboratory prototype of the fluxgate TSG has been developed and demonstrated (Fig. 16). This sensor features four commercial 3-axis triad sets of fluxgate magnetometers in a planar square array with a one-foot diagonal baseline. One triad set

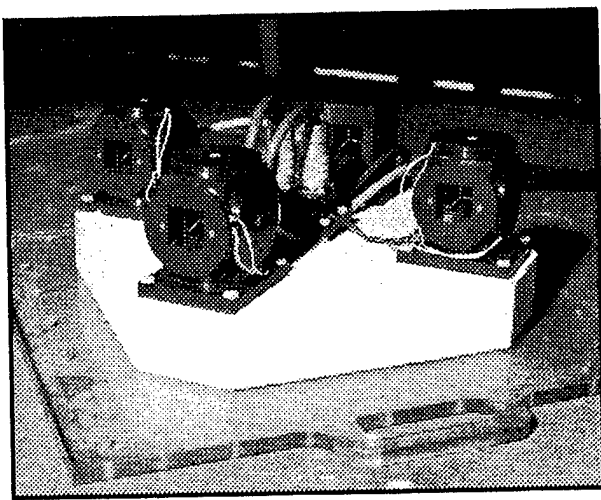


Figure 16. Laboratory prototype of a 5-channel fluxgate gradiometer utilizing the three-sensor -gradiometer concept.

of fluxgate magnetometers serves as a reference to measure the 3 mean magnetic field vector components at the array. The remaining three sensor triads are each mounted inside their own 3-axis Helmholtz coil sets which null the mean magnetic field at the sensor triad. The residual signals at the triads are processed through their commercial electronics and appropriate combinations are subtracted via differential amplifiers. In this manner, 6 tensor gradient terms can be calculated of which 5 are independent. In the laboratory prototype, analog electronics are utilized to implement the magnetic feedback currents with manual feedback adjustments determined to an accuracy of 5 decimals by a digital signal-processing routine. Sensitivity better than 0.3 nT/m at 0.1 Hz in motion has been demonstrated [28], [29].

A Phase I SBIR has recently been awarded to Quantum Magnetics to develop a ruggedized field-deployable version designed to improve the performance of the laboratory prototype. This version will be compact and light weight for man-portable operation. It will feature an integrated computer for fully automated sensor control and signal processing and a display to provide the operator easy target detection, classification, and localization.

This sensor offers the opportunity to become the mainstay for man-portable magnetic surveys, replacing the total field magnetometer by offering unambiguous detection, moment classification, and localization. Although its range will be limited by factors of 4 to 10 compared to the superconducting gradiometers described previously, this type of sensor will provide a low cost approach convenient for many applications and will avoid a need for cryogenes.

#### B. The High $T_c$ Version of the TSG

A project to develop and to demonstrate feasibility of a compact field-deployable high- $T_c$  superconducting gradiometer concept for mobile operation is being pursued by the CSS, IBM Research, Ball Aerospace, Quantum Magnetics, the Naval Research Laboratory, and Lockheed-Martin. As mentioned previously, it has been possible to fabricate high-sensitivity gradiometers in niobium technology by using monolithic wire or thin-film counterwound sense loops. Neither wire or thin-film monolithic loops can currently be manufactured using the high- $T_c$  technology to provide the higher sensitivities in motion offered by niobium technology. A high- $T_c$  gradiometer preliminary design has been established based on the TSG concept and its performance in motion has been modelled. The TSG approach circumvents the current limitations in high  $T_c$  manufacturing technology, providing long baselines by using normal metal wire to connect the two SQUID magnetometers. Further improvement in performance is expected using the high  $T_c$  SQUID magnetometers in place of fluxgate magnetometers as a result of their intrinsically greater sensitivity. A laboratory test article is being developed to evaluate this concept (Fig. 17). This test article incorporates two flux cubes with each flux cube consisting of 3 orthogonal high- $T_c$  SQUID-based magnetometers with dimensions of 1 cm<sup>3</sup>. The two cubes, separated by a baseline of approximately 30 cm, permit the synthesis of 3 tensor gradient components. For this test article, a 3-axis fluxgate triad is used to provide the 3 reference channels required in the feedback loop to null out the mean ambient background field. This high  $T_c$  gradiometer is expected to surpass significantly the motion performance of any conventional non-superconducting magnetic sensor technology and is projected to have sensitivity better than that of the low- $T_c$  SGMS.

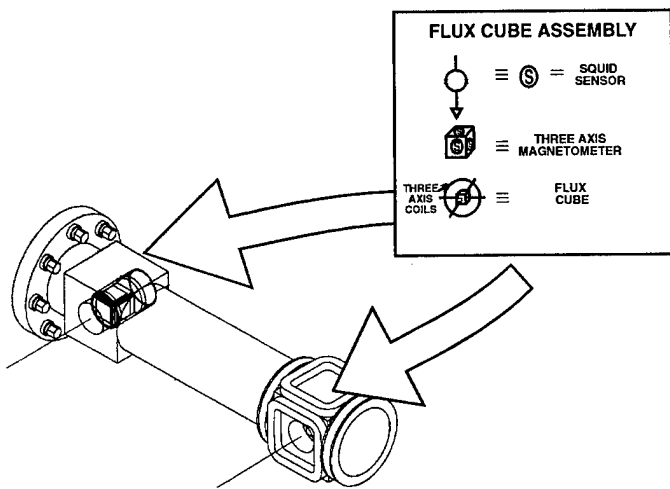


Figure 17. Concept for the laboratory prototype of a 3-channel high- $T_c$  superconducting gradiometer utilizing the three-sensor -gradiometer concept.

#### CONCLUSIONS AND SUMMARY

Magnetic sensors provide one tool valuable for mobile search operations and surveys for targets with a significant magnetic signature. Superconducting SQUID-based sensors theoretically represent the most sensitive of known magnetic sensors. SQUID-based magnetometers have been demonstrated with sensitivities on the order of  $1 \text{ fT/Hz}^{1/2}$  at frequencies down to  $0.1 \text{ Hz}$ , while fluxgate and total-field magnetometers are demonstrating sensitivities down to  $1\text{-}10 \text{ pT/Hz}^{1/2}$  at  $0.1 \text{ Hz}$ .

The U.S. Navy has developed the Superconducting Gradiometer/Magnetometer Sensor, a superconducting gradiometer which has provided long-range detection compared to conventional, non-superconducting magnetic sensors. This sensor has been utilized to demonstrate a capability for buried mine detection and clutter rejection. As a result of the multi-channel approach, the sensor provides an accurate localization capability and multi-target discrimination. The magnetic detection-and-classification signal processing developed in conjunction with the sensor has proven to be effective, providing a fully automated, real time capability. This high-tech sensor has provided reliable, rugged performance in undersea tows conducted over a period of seven years. The sensor has been operated in the same tow vehicle adjacent to a sonar without a loss in performance. This technology is available off-the-shelf to provide the greatest capability for magnetic detection and localization ever demonstrated. Work has continued recently with this sensor under the MUDSS Project to demonstrate its utility for UXO survey.

A new approach incorporating all thin-film niobium components is being pursued for greater detection range in mobile operation. A laboratory prototype is being evaluated with white noise on the order of  $50 \text{ fT/m-Hz}^{1/2}$  rising to approximately  $200 \text{ fT/m-Hz}^{1/2}$  at  $0.1 \text{ Hz}$  under stationary field conditions. A field-deployable version is

under development to be utilized in the Joint Countermine Advanced Concept Technology Demonstration in 1998.

It is only a matter of time before high- $T_c$  devices will be available with performance comparable to that which has already been demonstrated with low- $T_c$  devices. Magnetometer performance of  $140 \text{ fT/Hz}^{1/2}$  at  $1 \text{ Hz}$  has been demonstrated under stationary field conditions. This performance is a factor over 50 times better than the performance obtained from the best commercial fluxgate magnetometers. The benefits in reduced size, longer hold times, and reduced logistics and support make the high- $T_c$  approach attractive compared to its low- $T_c$  counterpart.

The localization capability afforded by 5-channel gradiometers (and not previously afforded by conventional magnetic sensors) is expected to add impetus to the acceptance of magnetics for mobile applications. The development of a 5-channel fluxgate gradiometer is currently in progress. Sensitivity better than  $0.3 \text{ nT/m}$  at  $0.1 \text{ Hz}$  in motion has been demonstrated.

As a result of a much lower cost and no special support requirements, such sensors will likely be sold in larger numbers for short-range applications. Their wider usage would then enhance the opportunity to display the utility of the greater classification and localization capability afforded by the 5-channel approach. With greater acceptance of the 5-channel approach, end users will likely want to obtain sensors with greater sensitivity. It is likely that the eventual development of high-performance, reliable high- $T_c$  gradiometers will work synergistically with an increased acceptance of the more powerful magnetic signal-processing approaches. Hopefully, the time scales for this supply and demand will be commensurate and so expedite sensor developmental efforts.

#### Acknowledgments

This work was supported by the U.S. Office of Naval Research, the U.S. Strategic Environmental Research and Development Program, and the U.S. Small Business Innovative Research Program. Among the many individuals who supported these developments at the CSS, the author acknowledges the contributions from G.I. Allen, G. Dobeck, M.C. Froelich, J.D. Lathrop, D.J. Overway, J.W. Purpura, L. Smedley, L. Vaizer, R.F. Wiegert, and W.M. Wynn. Finally the CSS would like to acknowledge the contributions from IBM Research, Ball Aerospace, Conductus, Quantum Magnetics, Lockheed Martin Federal Systems, the Naval Research Laboratory, and the Jet Propulsion laboratory including the more recent individual efforts from R.H. Koch, J. Rozen, J.H. Eraker, J.M. Schmidt, R. Cantor, P.V. Czipott, D.K. Lathrop, D. Gambrel, and R.J. Soulen, Jr.

#### REFERENCES

- [1] T. Clem, "Nitrogen Cooled Superconducting Gradiometers for Mine Reconnaissance from Small Underwater Vehicles" in the *Proceedings of the Symposium on Autonomous Vehicles in Mine Countermeasures*, pp. 6.91-6.102, April 1995.
- [2] T. Clem, "Superconducting Magnetic Sensors for Mine Detection and Classification," in *Detection Technologies for Mines and Minelike Targets*, Dubey, A.C., Cindrich, I., Ralston, M. and Rigans, K., (eds.), the International Society for Optical Engineering, pp. 374-383, April 1995.
- [3] J.D. Lathrop, J.F. McCormick, P.J. Bernstein, J.T. Bono, D.J. Overway, G.S. Sammelmann, T.H. Chao, and K.C. Scott, "Mobile Underwater Debris Survey System (MUDSS) Feasibility Demonstration report," in *UXO Forum 1996*

- Conference Proceedings, PRC Environmental Management Inc., pp. 427-436, April 1996.
- [4] D.C. Summey and G.J. KeKelis, "Fused airborne sensor technology," in *Detection and Remediation Technologies for Mines and Minelike Targets*, A. C. Dubey, R.L. Banard, C.J. Lowe, and J.E. McFee, Eds., the International Society for Optical Engineering, Proc. SPIE 2765, pp. 226-232, April 1996.
- [5] Jet Propulsion Laboratory Sensor Technology Assessment for Ordnance and Explosive Waste Detection and Location, JPL Report D-11367 Revision A, 1994.
- [6] W. M. Wynn, C. P. Frahm, P. J. Carroll, R. H. Clark, J. Wellhoner, and M. J. Wynn, "Advanced Superconducting Gradiometer/Magnetometer Arrays and a Novel Signal Processing Technique," *IEEE Trans. on Magn.*, Vol. MAG-11, pp. 701-707, March 1975.
- [7] W.M.Wynn, Magnetic Dipole Localization using the Gradient Rate Tensor Measured by a Five-Axis Gradiometer with Known Velocity, in *Detection Technologies for Mines and Minelike Targets*, Dubey, A.C., Cindrich, I., Ralston, M. and Rigans, K., (eds.), the International Society for Optical Engineering, pp. 357-367, April 1995.
- [8] The Jet Propulsion Laboratory, 4800 Oak Grove Dr., Pasadena, CA 91109.
- [9] M.G. Bello, "Hierarchical Multilayer Perceptron Network Based Fusion Algorithm for Detection/Classification of Mines using Multiple Acoustic Images and Magnetic Data," in *Detection and Remediation Technologies for Mines and Minelike Targets*, A. C. Dubey, R.L. Banard, C.J. Lowe, and J.E. McFee, Eds., the International Society for Optical Engineering, Proc. SPIE 2765, 1996, pp. 84-109, April 1996.
- [10] L. Smedley and G. J. Dobeck, "Automated sensor fusion for synthetic aperture sonar and magnetic gradiometer data," CSS TR-96/10, Coastal Systems Station, 1996.
- [11] The IBM Corp. Research Division, T. J. Watson Research Center, P.O. Box 218, Yorktown Heights, NY 10598.
- [12] Ball Aerospace Systems Division, P.O. Box 1062, Boulder, CO 80306-1062.
- [13] The Lockheed-Martin Federal Systems (formally Loral Federal Systems Company and the IBM Federal Systems Company), 9500 Godwin Drive, Manassas, VA 22110.
- [14] Quantum Magnetics, 7740 Kenamar Court, San Diego, CA 92121-2425.
- [15] Naval Research Laboratory, 4555 Overlook Ave., S.E., Washington, D.C. 20375-5000.
- [16] R.H. Koch, J.R. Rozen, P. Woltgens, T. Picunko, W.J. Goss, D. Gambrel, D. Lathrop, D. Overway and R.F. Wiegert, "High Performance SQUID Feedback Electronics," *Rev. Sci. Instrum.*, vol. 67(8), pp. 2968-2976, 1996.
- [17] J.H. Eraker, "Sensor temperature stability performance of the Advanced Liquid Helium Dewar," in *Advances in Cryogenic Engineering*, vol. 41, in press.
- [18] J. Eraker, "Cryogenic nitrogen cooling systems for a deployed high temperature superconducting magnetic gradiometer system," submitted for publication in *IEEE Trans. Appl. Sup.*, August 1996.
- [19] R. Cantor, L.P. Lee, M. Teepe, V. Vinetskiy, and J. Longo, "Low Noise, Single-Layer  $YBa_2Cu_3O_{7-x}$  DC SQUID Magnetometers at 77K," *IEEE Trans. Appl. Sup.*, vol. 5(2), pp. 2927-2930, 1995.
- [20] J.M. Schmidt, L.P. Lee, A. Mathai, A. Matlashov, M. Teepe, V. Vinetskiy, and R. Cantor, "Low-noise YBCO DC SQUID magnetometers for shielded and unshielded operation," unpublished.
- [21] J.W. Purpura, T.R. Clem, and R.F. Wiegert, "Nonlinear response in thin film magnetometer sense loops at 77K," *IEEE Trans. Appl. Sup.*, vol. 5(1), pp. 3123-3126, 1995.
- [22] J.Z. Sun, W.J. Gallagher, and R.H. Koch, "Nonlinear hysteresis in thin film magnetometers," *IEEE Trans. Appl. Sup.*, vol. 3(1), pp. 2022-2025, 1993.
- [23] J.W. Purpura and R.F. Wiegert, "Magnetic hysteresis in  $YBa_2Cu_3O_{7.5}$  magnetometer sense loops," submitted for publication in *IEEE Trans. Appl. Sup.*, August 1996.
- [24] R.H. Koch, J.Z. Sun, V. Foglietta, and W.J. Gallagher, "Flux Dam, a method to reduce extra low frequency noise when a superconducting magnetometer is exposed to a magnetic field," *Appl. Phys. Lett.*, vol. 67(5), pp. 709-711, 1995.
- [25] J.W. Purpura and J.M. Schmidt, "Evaluation of a three-channel high-temperature superconducting magnetometer system," unpublished.
- [26] R.H.Koch, "Gradiometer having a magnetometer which cancels background magnetic field from other magnetometers," U.S. Patent No. 5,122,744, 1992.
- [27] R.H. Koch, J.R. Rozen, J.Z. Sun, and W.J. Gallagher, "A three sensor gradiometer," *Appl. Phys. Lett.*, vol. 63(3), pp. 403-405, 1993.
- [28] G.I. Allen, R.H. Koch, and G. Keefe, "Unique man-portable 5 element fluxgate gradiometer system, in *Detection Technologies for Mines and Minelike Targets*, A. C. Dubey, I. Cindrich, M. Ralston, and K. Rigano, eds., the International Society for Optical Engineering, Proc. SPIE 2496, pp. 384-395, 1995.
- [29] R.H. Koch, G.A. Keefe, and G. Allen, "Room temperature three sensor magnetic field gradiometer," *Rev. Sci. Instrum.* 67(1), pp. 230-235, 1996.

# Passive Mine Detection

Charles H. Dabney

TRW

## Background

In the past the primary mission of IUSS (Integrated Undersea Surveillance System) has been the detection of submarines and surface craft in deep water. The changing political climate in the world has resulted in a redefining of threat priorities to include shallow, as well as deep water. The inclusion of shallow water operations as part of the primary mission will result in IUSS sensors in waters where mining might take place and raises the issue of what, if any, role could these sensors play in Mine Counter Measures (MCM) operations. To address this issue IUSS: (1) Studied acoustical signals related to mining; (2) Assessed the detectability of mines by passive and low frequency active sensors; and (3) Completed several Mine Exercises (MINEX) to measure the detectability of acoustic signal related to mining. At the time of this writing two MINEX test have been completed and a third is in progress. Two additional MINEX test are proposed for later this year. This paper describes work in progress, it gives the results of the analysis of measurements completed, and assess the potential of passive sensor support to MCM operations.

## Technical Issues

The goals of passive detection are two fold. First, complement other sensors. For example, attempts by the threat to minimize exposure to overhead sensors by completing the mine deployment mission in a short time or at night can increase the threat's vulnerabilities to passive detection means, exploit this vulnerability. Second, without alerting the threat, locate mine fields and: (a) provide an early warning to allied forces that hostilities, mining, have begun, (b) reduce the time for dedicated MCM forces to clear lanes and areas, and (c) identify lanes and areas that have not been mined.

To achieve these goals several technical issues have to be addressed. The MINEX test series are designed to address the following:

- (1) Identify mechanical induced acoustical events that are related to mine types and deployment methods, and assess their robustness.
- (2) Measure the radiated acoustical signal associated with identified acoustical events.
- (3) Measure the environments effects on signals identified.
- (4) Measure the radiated acoustic signature of vessel types that might be used in mine deployments.
- (5) Quantify signals that are potential sources of false alarms
- (6) Assess sensor requirements for the detection of mining.
- (7) Assess signal processing requirements.
- (8) Assess false alarms (sources and rates).

## Mechanical/Acoustical Sounds

A mine positioned for deployment has potential energy that is a function of its height above the water and weight,

$$\text{Energy} = \text{Weight} \times \text{Height}.$$

Releasing the mine to fall, converts the potential energy to kinetic energy (proportional to the mass and velocity squared),

$$\text{Energy} = 1/2 \times \text{Mass} \times \text{Velocity}^2.$$

The sounds that are produced as the mine deploys is the result of acoustical waves generated as the mine loses energy during deployment, before coming to rest on the bottom (surface impact, bubble plume that forms in the cavity as the mine submerges, cable payout for moored mines, bottom impact, etc.). This paper gives the results to date in an attempt to answer the question; Is the acoustical energy associated with mining exploitable (time sequence, energy level, bandwidth, duration and transmission losses)?

## MINEX Test Series

MINEX I and MINEX II were designed to investigate the acoustic energy radiated by mines as they are deployed. Data collected during these test has provided insight into issues (1), (2), (3), (6) and (7). MINEX III was designed to investigate detection performance against mine deployments and deployment craft. Data collected during this exercise will provide insight into issues (3), (4), (5), (6), (7), and (8). MINEX IV was designed to achieve the same objectives as MINEX III but in a different area and with a different sensor design. MINEX V is designed to investigate mine detection using low frequency active acoustics. A discussion of low frequency active is beyond the scope of this paper.

The MINEX series of test are an ambitious first step to collect data to assess the performance of IUSS type sensors in MCM operations. This paper discusses the resulting acoustic signatures that were derived from MINEX data, the mechanical sources, the range related detection performance, and the array and processing requirements. The relationship of mechanical events with acoustical events is necessary to show the potential for robustness in the mine signatures. Inclusion of IUSS type sensors in MCM operations in fleet exercises will provide further insight into the potential of passive detection of mining.

# Autonomous Detection and Classification of Bottom Objects with Multi-Aspect Sonar

Robert W. Floyd and John E. Sigurdson  
NCCOSC RDTE Division  
San Diego, CA

*Abstract* - Man-made objects, such as mines, usually have smooth surfaces from which specular reflections may be obtained when viewed at the correct aspect. The actual scattering pattern is primarily determined by the geometry of the surface of the object, and to a lesser extent by the internal structure. These patterns can be qualitatively estimated for simple objects, and these objects recognized when returns have been collected over a sufficient change in aspect. An added advantage of looking for specular returns is that they normally provide a much higher echo to noise or reverberation ratio than does scattering from oblique angles. This allows target echoes to be collected with relatively high detection rate for a constant false alarm rate (CFAR) detector, with most of the detected signals discarded later because the specular returns are absent.

Two sets of experiments were conducted at the former NRaD Hawaii Detachment. The first experiment looked at a set of targets placed on a sediment tray that could be rotated over 360 degrees. Echo data were collected from a variety of targets using a transducer that transmitted a wide band, dolphin like signal. Targets were classified as either natural objects (rocks, coral heads), or man made objects. Classification was 100 % when the targets were viewed over >180 degrees. The performance dropped to 90% with aspect changes of 60 degrees to 120 degrees, and dropped rapidly for aspect changes below 60 degrees.

The second experiment looked at objects on the bottom of Kaneohe Bay while the sonar moved. To obtain wide band signals with a multi-beam sonar (120 degree sector, 40 beams), an acoustic lens system was constructed. Data were collected simultaneously on all 40 beams as the sonar was towed. The data were initially processed with a CFAR detector. The position of the sonar was determined by calculating a position that gave a minimum error in the position of the CFAR detection's from ping to ping. Over the course of the vehicle (100 meters) the absolute navigation error was measured to be less the 25 cm. Once the position of the vehicle had been estimated for each ping, target files containing the echoes at all aspects for each point on the bottom meeting the CFAR criteria were developed. The files were processed to extract features, and the object classified as to man made or natural. All targets placed in the field were detected, along with several buried objects that were in the area, but previously unknown to the investigators. Over 90% of these objects were correctly classified as to man made or natural.

## I. INTRODUCTION

The multi-aspect classifier uses features derived from multiple pings on a target at varying aspects to make a classification of the target echo. Most man-made objects contain either flat or curved surfaces. At certain aspects, these surfaces give rise to specular returns that are significantly greater than echoes obtained from the target at oblique angles or from scattering surfaces on the bottom. By extracting a small set of features relating to these scattering phenomena, a statistical basis can be obtained for separating natural from man made objects. This is, most likely, functionally equivalent to one of the methods used by the dolphin to successfully discriminate man made objects such as mines from other natural objects with its biosonar. In certain cases, simple man-made objects can be identified as a member of a subclass of man-made objects such as mines. The process of developing files for feature extraction also aids in target detection. The detection level for any echo may be set quite low (<9 dB), with most contacts rejected because there are insufficient threshold crossings over time, or because the object exhibits no specular returns. This ability to discriminate against inconsistent returns, along with the wide bandwidth of the signal, enable the classifier to pick out objects which are barely above the reverberation level.

The target features are derived from a file containing multiple echoes of the target. It is assumed that the sonar with multiple preformed beams or scan-within-pulse (SWP) is on a vehicle in motion, so that the every target passes through

multiple beams as the vehicle flies through the target field. To obtain these files, the object must be detected, tracked, and the section of the return containing the target echo stored in memory. This in turn requires that at each ping the system must be able to predict on which beam and at what range the echo from each target will occur.

The system concept is shown in figure 1. The received echo is passed through a constant false alarm receiver (CFAR). If the signal exceeds a threshold, it is passed to the target tracker. The tracker gets the current position of the vehicle from the navigation processor, and calculates the position on ground of the new contact. If the tracker already has a contact in the vicinity, the new echo is appended to an existing file. Otherwise, a new track is established. If a target track has been established for a contact at a particular location, data from that location will be added to the file even if the echo is not strong enough to trigger the CFAR.

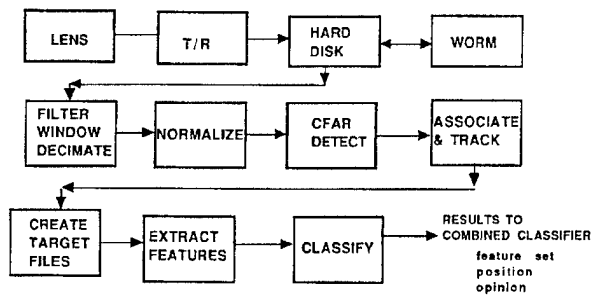


Figure 1. Multi-aspect classifier block diagram.

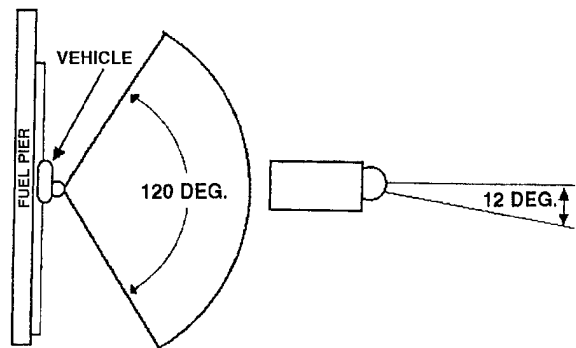


Figure 2. Schematic diagram of the coverage of the lens. During data collection, the lens looked out 90° relative to the direction of travel along a wire mounted parallel to the pier (left). The vertical coverage extended 12° down from the center of the lens. To get coverage of the near targets, the entire lens was tilted down 2-3°.

While the above description applies to a system in which data are processed on the fly, we used a different non-tracking method for target detection and data extraction to be described. Also, all data were collected and processed off line. This allowed us to process the data in several stages, which included pre-processing, establishing a vehicle track, initial detection and clustering of simple contacts into objects, and finally target-data extraction. Besides avoiding the cost of a real time processor, this method allowed greater efficiency in optimizing the low level detection and data extraction algorithms. We chose an acoustic lens developed by the Applied Physics Laboratory of the University of Washington as our multi-beam sonar for two reasons. First, the acoustic lens is a very compact, low power SWP sonar which makes it attractive for small autonomous vehicles. Second, at the time, an acoustic lens was the only sonar that provided 50 kHz bandwidth with 120° aspect coverage that could rapidly be developed.

The data collection and analysis were conducted in two stages. The first set of data were collected by ensonifying different targets on a rotating tray of sediment with a sonar in a fixed position and a second set of experiments in which a large target field was placed on the bottom and the multi-beam sonar was moved past the field (Figure 2). In the first phase the targets were selected by the investigators. In the second experiment, the targets were selected and placed by another group in two tests, one in which the investigators knew which objects were placed, and a second in which the targets and their positions were unknown. The data of the unknown targets will be presented here.

## II. SAND BOX EXPERIMENTS

Prior to the availability of the acoustic lens system, we collected data on a small number of targets. The purpose of these tests was to get a preliminary idea of which features would prove effective, and to make an estimate of the

minimum angle of aspect change over which we could reliably classify the contacts. For these experiments, the data collection system consisted of a rotating sand box in the test pool on which the targets were placed, and two wideband data collection systems using 40 kHz BW pings centered at 100 and 300 kHz. It was expected that any frequency dependency of this method would show when using such a wide range of frequencies. Data were collected by pinging on the target at one degree increments. Several pings were taken at each angle to ensure that we obtained a good echo at each aspect. In practice, this was not a problem and we created our data files taking the first ping at each angle. These data then became our target files.

We attempted to use a fairly broad range of targets. These included simple geometric targets such as spheres and cylinders, more complicated objects such as chairs, a trash can, 500 LB bomb, etc., and representative natural objects including rocks and coral heads.

#### A. Target characteristics.

As expected, the various objects showed strong scattering characteristics related to their geometry. The differences between the patterns taken at 300 kHz and 100 kHz were not obviously different for the individual targets. However, at 100 kHz the signal penetrated the 6 inches of sand in the sediment tray to reveal the structure of the tray.

Figure 3 is an example of four of the targets used in the sand box. The item on the top right was a flooded aluminum cylinder of 15 cm. diameter and 50 cm. length laying on its side. The extremely narrow lobes were from the sides, and the broader lobes from the top and bottom plates.

The target at top left was a 500 LB bomb. The two relatively broad lobes were from the curved sides, and the smaller split lobes at 60° were from the tail. From the front of the bomb, the echo level is not significantly above the reverberation, and it would probably not be detectable from that aspect alone.

The bottom left is a lava rock with irregular faces. There are a few specular reflections, but

these are not as high as those from the cylinder and bomb. However, its mean target strength is higher than either the bomb or the cylinder.

The last target illustrated was a small coral head that had numerous small branches rather than being a dense mass. It had no major specular reflections, and its mean target strength was also low.

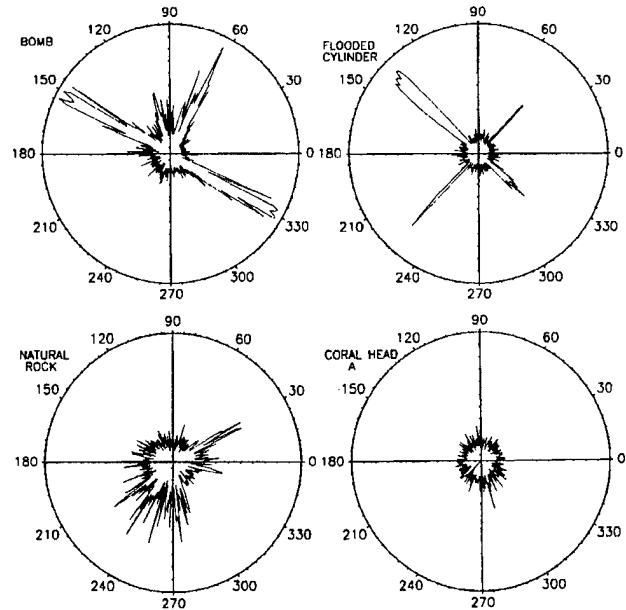


Figure 3. Examples of the scattering strength vs. aspect of four targets from the sandbox tests.

#### B. Sandbox results

Since the target position was known *a priori* and the signal to noise ratio was high, there was no special signal processing used. We had hypothesized that man-made objects could be separated from natural targets based strictly on scattering statistics. The peak amplitude of the echo at each aspect was taken. For each target, the following set of features were generated from the array of maxima:

- a. The standard deviation of the maxima
- b. The maximum to mean of the maxima
- c. The maximum to mode of the maxima

We expected man-made targets to have relatively high values for each of these because, typically, the scattering energy would be concentrated at a small number of aspects.

To make the classification, the geometrical



center in feature space of the targets was calculated. For each target being tested, the feature archetype was recalculated with the test target excluded. The classification was made based on the distance of the test target in feature space from these archetypes. When 360° of data are used to make the classification, the performance was 100%.

In any realistic system, it is unlikely that any target would be viewed over more than 140° of aspect change. Therefore, the same detection criteria were applied to target files in which limited aspects were available for viewing. This was intended to simulate what a vehicle proceeding on a straight path would see. This scenario was simulated by using limited portions of the 360° files at different starting points. For example, when testing how the system would perform when the target was seen over 90°, we would take 90° segments at every 15° and

**Table I.**

Moderate angle classification performance of the multi aspect classifier. (N-natural, A-man made)

Target	60°		90°		120°		360°	
	N	A	N	A	N	A	N	A
Coral 1	8	0	8	0	8	0	1	0
Coral 2	8	0	8	0	8	0	1	0
Rock	8	0	6	2	8	0	1	0
55gl drum	2	6	2	6	1	7	0	1
Solid Cyl	0	8	0	8	1	7	0	1
Bomb sim	2	6	2	6	1	7	0	1
Chair	0	8	1	7	0	8	0	1
Trash Can	0	8	0	8	0	8	0	1
Flood Cyl	1	7	1	7	3	5	0	1
YB	1	7			1	7	0	1
% correct	92.5		90		91.3		100	
PD	89.3		89.3		87.5		100	
PFA	0		8.33		0		0	

compute the three features. This feature was then compared to the archetype, which had been

computed using the full 360°. Table I shows the performance of the system at various portions of aspect change in terms of the probability of making a correct choice, the probability of correctly identifying a contact as man-made (PD), and the probability of identifying a natural object as man-made (PFA).

These angles represent the range in which we expect to work. Surprisingly, there was no

**Table II.**

Small angle classification performance of the multi-aspect classifier.

Target	50°		40°		30°		360°	
	N	A	N	A	N	A	N	A
Coral 1	15	0	18	0	24	0	1	0
Coral 2	15	0	18	0	24	0	1	0
Rock	13	2	13	5	16	0	1	0
55gl drum	7	8	10	8	14	10	0	1
Solid Cyl	1	14	6	12	10	14	0	1
Bomb sim	7	8	10	8	14	10	0	1
Chair	0	15	1	17	2	22	0	1
Trash Can	4	11	7	11	11	13	0	1
Flood Cyl	7	8	9	9	13	11	0	1
YB	5	10	8	10	13	11	0	1
% correct	78		68.9		64.6		100	
PD	70		59.5		54.2		100	
PFA	4.4		9.3		11.1		0	

difference in performance for these targets between 60° and 90° of aspect change. This may be a peculiarity of the combination of targets chosen and the increments at which we selected data to obtain features. On the other hand, these numbers are not too different from what was later achieved with the moving sonar.

We had expected to see a pronounced drop in performance as we approached 60°. Since this did not happen, we continued to narrow the aspect change, from 50° down to 30°. Over this range, the performance dropped rapidly. This indicates

that data collected over aspect changes of less than 60% will not be very reliable. In a sense, the results may be worse than they appeared. The performance was strongly affected by the coral heads and the chair. The coral heads always looked like natural objects, and the chair almost always looked like a man made object. In practice, this suggests that large/complex objects will probably be detected with a minimal aspect change, but that other objects may need at least 60° to be classified with any confidence

### III. FUEL PIER EXPERIMENTS

The data at the fuel pier were collected with the acoustic lens sonar (fig 2). The sonar was configured as two identical banks of electronics, each controlling 20 beams. Each receive beam was 3° horizontal by 12° vertical. The envelope of each return was band limited to 30 kHz and sampled at 70 kHz with a 12 bit analog to digital converter. These samples were serial multiplexed and sent to the recording system over a fiber optic link at 16 mbit/sec. The data was record on an Thorn/EMI recorder, and later transferred to an optical disc.

The sonar returns and sonar orientation data were used to produce a map of all contacts, their 3-D coordinates relative to the initial position of the vehicle, and a separate file of sonar data for each contact that met certain criteria. The system incorporates a complete general model for the dynamic geometry of a mobile, multiple-beam sonar and includes methods for correcting differences in sensitivity between beams *in situ* and resolving the azimuth ambiguity. The system is implemented in APL\*PLUS II.

The analysis is completely automated and proceeds in three stages, navigation, mapping and target-file extraction. In navigation, a subset of the sonar contacts and the attitude sensors are used to determine an accurate track of the sonar platform over the ocean bottom. In the mapping stage the locations of simple contacts are determined from the data of each ping. The

contact information from all pings is integrated to locate clusters of simple contacts that define objects. Although the present demonstrations use relative signal strength as the defining characteristic of a contact in both the navigation and mapping stages, those stages are independent. In other words, different processing and criteria may be used to establish contacts in the two stages. In the final stage of mapping, data specific to a detected target are isolated and extracted for subsequent classification.

With the fuel pier data, the mapping system established a 3-D space of the ocean as a common frame-of-reference for all geometrical analyses and used stochastic methods to estimate contact position.

#### A. Preliminary processing

The processing requires that the signals be normalized for differences in sensitivities between beams. The correction was taken from a one-time calibration of the sonar. Using pings of an actual sonar run, the value in each range-bin of each beam was measured across pings, the measures sorted and a value at a constant index of the sort order was selected as a typical return for each range-bin. The index chosen avoided abnormally low or high returns from our introduced targets. An array that was isomorphic with a typical array of ping data was formed with these values for use in subsequent DC correction of the raw ping data.

#### B. Navigation

The pivotal feature of the mapper is the establishment of a frame-of-reference in ocean-space relative to the start of data collection, and the determination of the ping-to-ping position and attitude of the sonar head as it moves through that space. The mapper starts with an estimated track through ocean-space and then brings that estimate closer to the true track by navigating on available bottom-features. The complex geometry of the sonar beams, the sonar head, the sonar body, the platform carrying the sonar and their relation to the 3-D space of the ocean are described by a model with a planar array for the beams and four,

3-D coordinate systems, one for each component. The complete model accounts for rotation of any axis of any coordinate system or translation of any coordinate system relative to the others on a ping-to-ping basis. Further, any additional system (e. g. a side-scan sonar) and its data can be integrated into the model thus fusing the sonar fields of both systems into a single deterministic geometry.

The point on the ocean floor beneath the sonar platform on the first ping of a run is taken as the reference coordinate (0,0,0) for the run and an estimate of the platform's track is made from its estimated course and speed. This track is subsequently corrected by comparing the distribution in ocean-space of the dozen or so strongest contacts on a given ping with the distribution of the strongest contacts detected ten pings later. An iterative series of comparisons is made between the two patterns while varying the offset in the direction of travel until the offset of maximum registration between patterns (or minimum divergence) is obtained. A correction based on the difference between the estimated and corrected position of the second ping is applied to the estimated track between the two pings and the process is repeated using the newly corrected location as the basis for the next correction etc..

The present demonstration uses a wire-guided progression of the sonar platform and requires corrections along only the direction of travel but, this method is easily extended for correction in three dimensions. The method does not depend on the "tracking" of specific contacts from ping-to-ping but, rather, relies only on the likelihood that a high proportion of objects or features that are detected as strong targets at one position will also be detected as such when the sonar has advanced only a few meters. That is, the method is designed to continuously adapt to the ever-changing population of objects moving through the sonar field and the ever-changing aspects that they present to the sonar. Also, note that although there is inherent error in estimating a given contact's position on a single ping due to beam-width, the position errors of multiple contacts between-pings are random and tend to cancel one another when a

sufficient sample size is used with a maximum registration criterion.

### C. Mapping

With the corrected track as the basis for back projection of sonar contacts into ocean-space, a file of simple-contact coordinates is generated. A graph of all the contacts detected in the demonstration appears at the top of Figure 4. The vehicle travels along the ordinate (parallel to the pier) with the center beam of the sonar oriented perpendicular to the pier. The track starts at the intersection of the ordinate and abscissa and proceeds upward along the ordinate to 44m. Objects appear as smeared concentrations of points in the graph due to the imprecision of the 3° beam width, environmental noise, side-lobes, beam-straddles, and the 3.6 to 1 vertical compression of the graph. The environmental noise is caused by high concentrations of snapping shrimp in Kaneohe Bay. The first four corrections to the contact data involve resolution of electronic noise, environmental noise, side-lobes and beam-straddles. As these forms of interference appear on the affected beams simultaneously, the collective term "time-correlated-interference" (TCI) is used to describe them as a group and a single algorithm is used for their identification and resolution. Sets of contacts identified as electronic or environmental noise are eliminated from the file while sets of points determined to be either side-lobes or beam-straddles are resolved to a single contact at the location with the largest aggregate energy in its return. The center graph of Figure 4 shows the contacts remaining after removal of the TCI.

The next stage of the analysis resolves the ambiguity of a contact's position resulting from beam width. Successive contacts on a given beam that display the characteristic pattern of motion through the beam are grouped and the average ocean-space position is taken as the location of the contact. An index of detectability called the grouping index (GI) is the ratio of actual hits in the grouping to the number of possible hits that could have occurred as that specific beam passed

over that specific point in the ocean. The resultant contact-data indices are then aggregated over all beams for all points, but the aggregations remain identifiable by their high GI. The bottom graph in Figure 4 shows the contact data after reduction of the position ambiguity caused by beam-width. Here, the number of points at the location of significant objects and their spatial dispersion are reduced while weak contacts not associated with objects remain unchanged with a low GI.

With the contact file now free of TCI and the spatial ambiguity of beam width reduced, the resulting contacts that fall within a given distance of each other are gathered into a primary cluster and the center of that cluster is determined and recorded as a single point. The number of contacts that go into the primary cluster is recorded as "N". The grouping indices of the individual contacts that go into the cluster are summed to become the grouping index of the cluster. A coverage index (CI) is computed that is the ratio of total number of pings in the sonar run to the number of pings covering a given location. It is used in the last stage as a correction for objects that were on or near the periphery of the field and were not ensonified as many times as those contacts in the center of the field.

The final steps in locating objects involve a secondary clustering of primary clusters within a minimum distance of each other and sorting those objects in descending order of their aggregation scores. A cluster count (CC) reflecting the number of primary clusters subsumed is recorded. Also, N and GI are updated to reflect the sum of those parameters for the primary clusters subsumed.

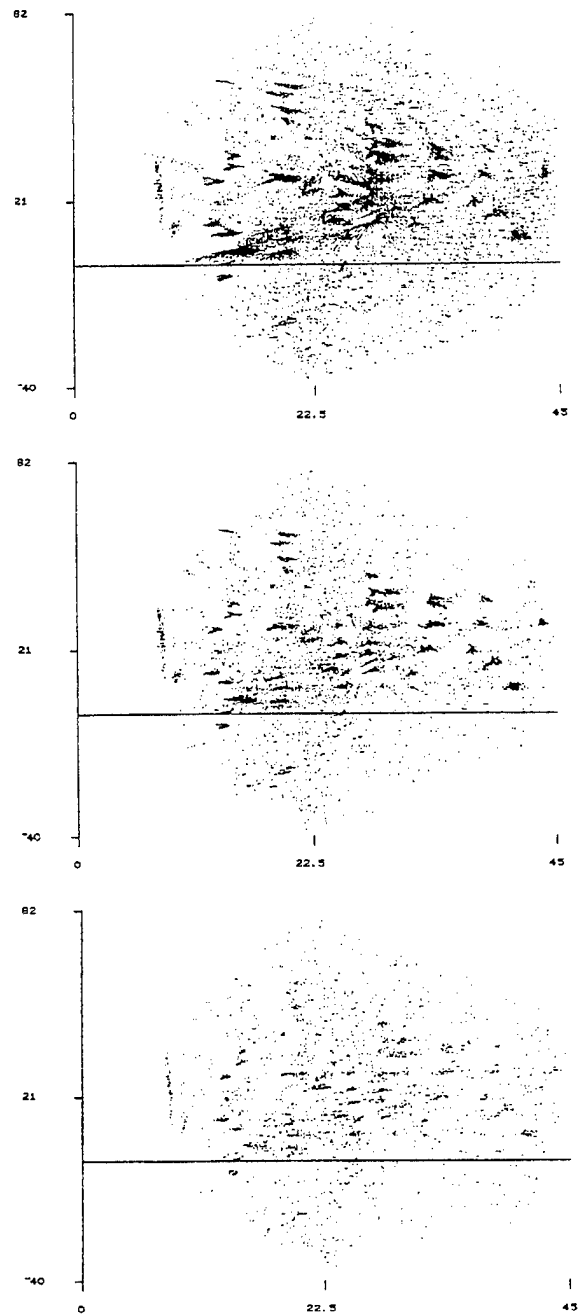


Figure 4. The stages in target detection. The top figure shows all of the initial simple contacts where each dot indicates a threshold crossing. The middle figure is the contacts remaining after time-correlated-interference such as side lobes and snapping shrimp has been removed. The bottom shows the final stage after azimuth ambiguity has been reduced. The successive reduction in overall blackness shows the elimination of noise and azimuth ambiguity.

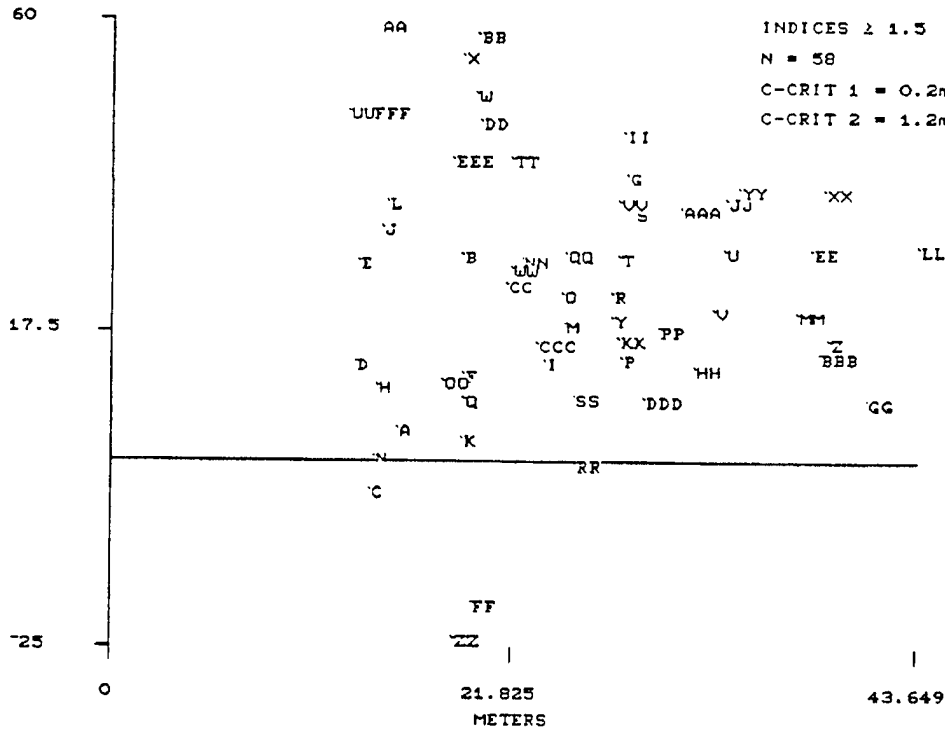


Figure 5. A plot of the demonstration contacts. The direction of travel along the pier is towards the top of the page. The contacts detected below the horizontal line were outside our target field and, therefore, not classified. There is an approximately 5:4 vertical compression of the scale.

LAB. PCAT	SCAT	X	Y	Z	H	GI	CI	HFI	CC	A	B	C	D	E	F	G	H	I	J	K	L	M	N	...
A		15.5	0.8	4.7	80	51.90	1.25	64.62	8	0.0	23.9	8.5	9.1	22.9	8.1	36.8	5.9	12.2	27.5	3.8	31.1	16.8	4.0	...
B		19.1	0.2	28.3	87	54.46	1.00	54.46	5	23.9	0.0	32.3	15.9	5.8	16.4	14.2	18.4	15.2	5.9	25.1	8.5	11.1	27.8	...
C		14.0	1.2	-3.7	39	20.20	1.81	36.53	4	8.5	32.3	0.0	17.1	31.1	16.4	45.2	14.1	19.9	35.8	8.5	39.4	24.8	4.6	...
D		13.2	1.4	13.5	44	31.30	1.13	35.31	2	9.1	15.9	17.1	0.0	14.0	6.1	29.7	3.3	10.4	18.8	11.8	22.3	12.6	12.6	...
E		13.3	1.4	27.5	44	29.29	1.14	33.33	1	22.9	5.8	31.1	14.0	0.0	16.6	18.8	17.1	17.1	4.9	25.0	8.4	14.3	26.6	...
F		19.1	0.3	11.9	39	32.28	1.00	32.28	3	8.1	16.4	16.4	6.1	16.6	0.0	28.8	4.9	4.9	20.8	8.7	24.2	8.8	12.0	...
G		27.9	-1.4	39.3	91	31.76	1.00	31.76	10	36.8	14.2	45.2	29.7	18.8	28.8	0.0	31.8	25.9	15.1	37.2	13.5	20.8	40.7	...
H		14.4	1.1	10.4	44	27.20	1.14	30.95	2	5.9	18.4	14.1	3.3	17.1	4.9	31.8	0.0	9.7	21.7	8.6	25.3	13.1	9.6	...
I		23.6	-0.6	13.8	62	29.58	1.00	29.58	6	12.2	15.2	19.9	10.4	17.1	4.9	25.9	9.7	0.0	20.5	11.6	23.6	5.1	15.9	...
J		14.7	1.1	32.2	36	24.27	1.19	28.86	2	27.5	5.9	35.8	18.8	4.9	20.8	15.1	21.7	20.5	0.0	29.3	3.6	16.7	31.3	...
K		19.0	0.3	3.1	44	26.35	1.06	27.82	5	3.8	25.1	8.5	11.8	25.0	8.7	37.2	8.6	11.6	29.3	0.0	32.8	16.6	5.2	...
L		15.0	1.1	35.7	32	20.57	1.31	26.88	2	31.1	8.5	39.4	22.3	8.4	24.2	13.5	25.3	23.6	3.6	32.8	0.0	19.6	34.8	...
M		24.6	-0.7	18.7	37	23.99	1.00	23.99	2	16.8	11.1	24.8	12.6	14.3	8.8	20.8	13.1	5.1	16.7	16.6	19.6	0.0	20.6	...
N		14.3	1.1	0.9	24	15.92	1.50	23.87	3	4.0	27.8	4.6	12.6	26.6	12.0	40.7	9.6	15.9	31.3	5.2	34.8	20.6	0.0	...
O		24.5	-0.6	23.1	31	23.30	1.00	23.30	3	20.5	7.5	28.8	14.9	12.0	12.4	16.5	16.2	9.4	13.4	20.7	15.8	4.4	24.4	...
P		27.7	-1.2	14.2	29	22.78	1.00	22.78	3	15.5	16.5	22.5	14.5	19.6	8.9	25.1	13.8	4.1	22.2	14.1	25.0	5.5	18.9	...
Q		19.1	0.3	8.5	39	22.56	1.00	22.56	3	5.2	19.8	13.2	7.7	19.9	3.4	32.1	5.1	6.9	24.1	5.3	27.6	11.6	9.0	...
R		27.2	-1.1	23.0	29	22.50	1.00	22.50	4	21.7	9.7	29.7	16.9	14.6	13.7	16.3	17.9	9.9	15.5	21.5	17.7	5.0	25.6	...
S		28.2	-1.3	34.3	32	21.01	1.00	21.01	5	32.2	11.0	40.5	25.7	16.4	24.2	5.0	27.5	21.0	13.8	32.5	13.4	16.0	36.2	...
T		27.5	-1.2	28.2	32	20.52	1.00	20.52	4	26.4	8.4	34.6	20.5	14.2	18.3	11.1	22.0	15.0	13.4	26.5	14.6	9.9	30.3	...
U		33.2	-2.2	28.9	28	19.71	1.00	19.71	4	30.0	14.2	37.8	25.3	20.0	22.1	11.7	26.3	17.9	18.8	29.4	19.5	13.3	33.8	...
V		32.6	-2.1	20.9	27	17.59	1.00	17.59	4	23.6	15.5	30.8	20.8	20.4	16.2	19.0	20.9	11.5	21.2	22.3	23.1	8.3	27.1	...
W		19.7	0.2	50.3	14	9.82	1.59	15.61	2	45.9	22.1	54.3	37.4	23.7	38.4	13.8	40.2	36.8	18.9	47.2	15.3	32.0	49.7	...
X		19.0	0.3	55.4	9	6.82	2.06	14.07	2	50.9	27.2	59.3	42.4	28.6	43.5	18.4	45.2	41.9	23.7	52.3	20.1	37.1	54.8	...
Y		27.2	-1.1	19.7	21	12.80	1.00	12.80	4	19.0	11.8	26.9	15.3	15.9	11.2	19.6	15.7	6.9	17.6	18.5	20.1	2.7	22.8	...
Z		38.8	-3.2	16.5	16	11.53	1.00	11.53	4	26.1	23.0	32.0	25.8	27.8	20.2	25.3	25.1	15.5	28.8	23.9	30.7	14.4	29.1	...
AA		14.5	1.2	59.6	3	2.21	5.08	11.24	1	55.0	31.7	63.3	46.2	32.2	48.0	24.4	49.2	46.8	27.5	56.7	23.9	42.2	58.7	...
BB		19.8	0.2	58.2	9	4.88	2.24	10.91	3	53.7	29.9	62.1	45.2	31.4	46.3	20.6	48.0	44.6	26.5	55.0	22.9	39.8	57.5	...
CC		21.4	-0.1	24.3	21	10.69	1.00	10.69	4	20.5	4.6	29.0	13.6	8.7	12.7	16.3	15.5	10.8	10.3	21.3	13.1	6.5	24.5	...
DD		20.0	0.2	46.6	15	7.73	1.36	10.52	2	42.2	18.4	50.6	33.8	20.3	34.7	10.8	36.6	33.0	15.4	43.5	12.0	28.3	46.1	...
EE		37.9	-3.0	29.0	16	9.77	1.00	9.77	3	33.1	18.9	40.5	29.2	24.7	25.4	14.3	29.9	20.9	23.5	32.0	23.9	16.8	36.7	...
FF		19.6	0.2	-18.6	6	4.29	2.28	9.76	2	23.7	46.9	16.0	32.7	46.5	30.5	58.5	29.5	32.7	51.1	21.8	54.6	37.7	20.2	...
GG		40.9	-3.5	8.2	17	8.56	1.00	8.56	2	25.7	29.7	29.5	28.3	33.7	22.1	33.7	26.6	18.2	35.6	22.5	37.8	19.4	27.7	...

Figure 6. A portion of the object table. The table lists the objects in descending order of HFI scores with their respective ocean coordinates and indices already described. The cross-tabulation beginning in column A gives each object's distance in meters to all other objects of the set.

This cumulative GI is multiplied by CI (i. e. the correction for peripheral objects) to produce a corrected GI or hit-frequency-index (HFI) for the final clustering. In the generation of the object map, cross-tabulations and object data files, all objects are sorted on the basis of their HFI scores and those above a given threshold are reported and passed for subsequent classification. Figure 5 shows a final map of the objects with HFI scores greater than 1.5 that had a minimum distance for primary clustering of .2m and a minimum distance for secondary clustering of 1.2m. Labeling proceeds from A to Z and then from AA to ZZ etc.. Figure 6 is a log of all contacts. In this and other tests with other target distributions, the mapper method routinely detected all artificial targets and intentionally placed natural objects by setting the HFI criterion to include fewer than 20% more than the number of intentionally placed targets. This demonstrates the method's ability to achieve high discriminability between small targets and background while maintaining an extremely low false alarm rate.

#### D. Target-file extraction

The process of creating target files for feature analysis consists of extracting echo data from each ping about the estimated location of a point on the leading edge of the target. A series of range-bin values is taken from each ping on each beam as long as that beam is encompassing the target (later versions of the method extract only the one ping that occurs as each beam crosses and is centered on the leading-edge point, a process that yields, at most, 40 returns for each target with a 40-beam sonar). Viewed from overhead, each such return begins before that point, crosses through the point and continues a distance beyond that is determined by an estimate of the spatial extent of the target. When successive returns are gathered into a rectangular array and graphed, as in Figure 7, there is a tendency for the leading edges of the target-returns for a point target to fall away slightly when the sonar is viewing it from either extreme aspect and to show systematic drift across the beams as a function of accumulating navigation error across

the run. Figure 7 is an example of the target file

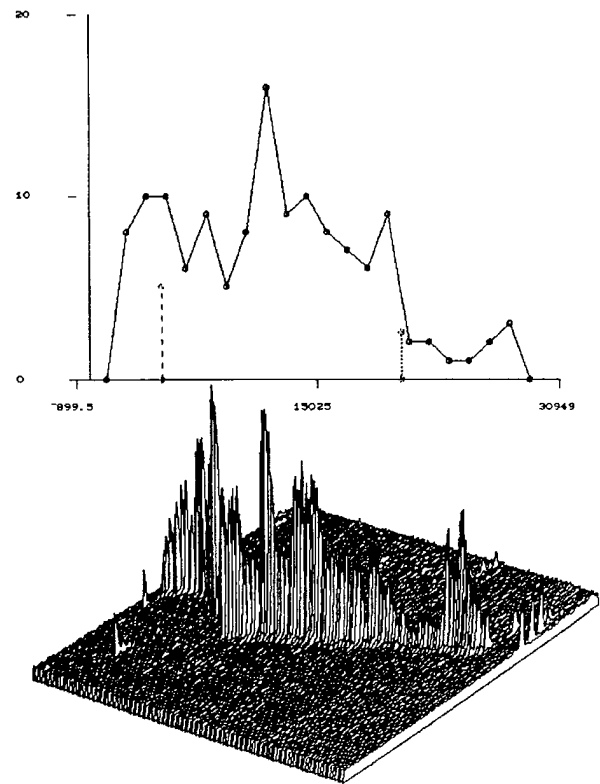


Figure 7. This is the target file from a point target (tri-plane). The echo data are plotted in the lower half. Each trace is 256 samples, or approximately 1 meter in length. The top trace is a histogram of the maxima from each trace. The target features used are derived from these maxima.

from a tri-plane, which appears to the sonar as a point target. Note that the target echo is consistently near the center of the file. This indicates that the estimated position of the leading edge point was extremely precise - within 2-5 cm. The drift across the file of about 20 cm indicates that degree of cumulative navigation error across the 40+ m run. That is, the navigation correction method employed resulted in only about 20 cm per 40 m of advance which, in a real-world application, could be corrected periodically with internal inertial reference, an external reference or prepositioned reference targets.

#### E. Features of demonstration targets

As in past experience, the man-made targets tended to be spread out in feature space.

Nevertheless, it is possible to group them in three broad categories: complex targets with multiple strong scattering surfaces; simple targets with one strong reflecting surface or point; and targets with no strong scattering surfaces. The latter were the only targets likely to be confused as a natural target.

Complex targets include those with several scattering points and also the case of two or more small targets within about a meter of each other. The multi-aspect classifier, at this stage of development, does not distinguish between two objects close together versus two objects connected by a component with a low scattering strength.

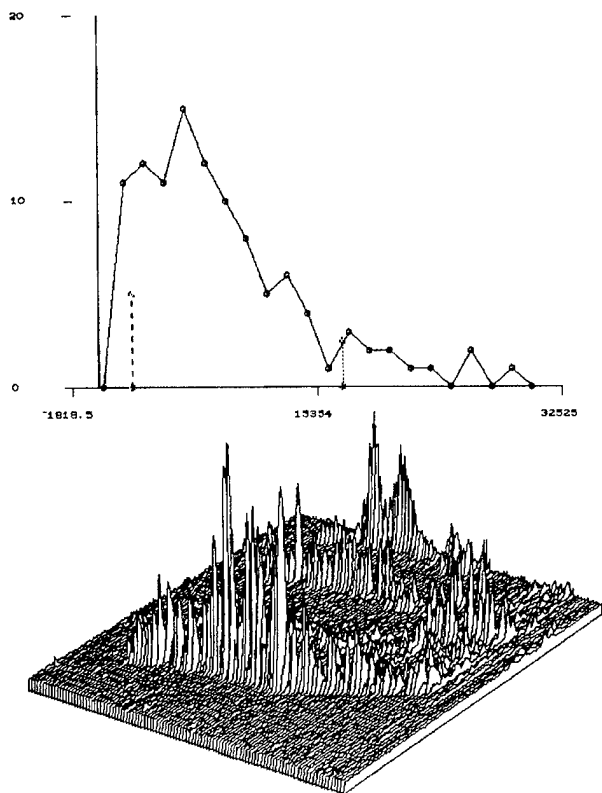


Figure 8. The scattering strength plot of a trash can. The top plot is a histogram of the maxima for all the pings. On the waterfall plot, each line represents a sample section of the echo that is approximately two meters long. In this case the target was in view for 107 pings, and 107 lines are shown. Each line is at a different aspect, but the change in aspect depended on target range, vehicle speed, etc..

Figure 8 is an example of a moderately complex target. It is a trash can, and reflects strongly from

the side, top or bottom, and at corners near the bottom. As seen in figure 8, at most aspects there were three distinct returns. After the initial reflection there is some scattering from various protuberances, such as handles, on the side. Although it is possible to imagine the scattering strength plot representing a hollow object, remember that the scattering is plotted as a function of aspect change, not linear travel.

Figure 9 is an example of two simple targets near each other, in this case two cement blocks.

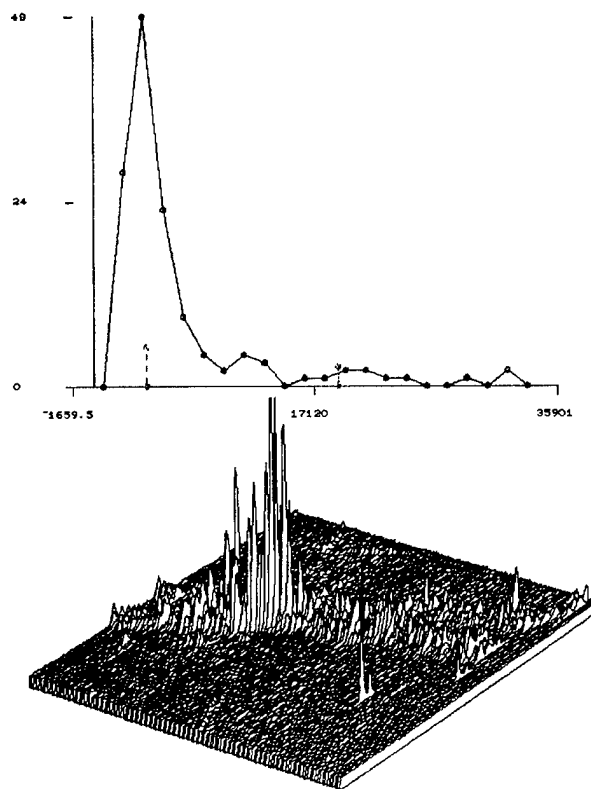


Figure 9. The scattering strength plot of a two cement blocks. The 'X' pattern caused by the change in apparent positions as the vehicle passes by the two targets.

This produces an 'X' pattern in scattering as the aspect changes. When the pair are first seen by the sonar, one block is closer to the sonar than the other. As the vehicle passes by, the separation decreases until they are the same range at beam aspect. This is also the aspect at which the target strength is the maximum, as seen by the bright

reflections. After that beam aspect the distance between the targets appears to start increasing again, with the original near target now becoming the far target.

In some cases two adjacent targets were of considerably different scattering strength. Figure 10 is the target file that contains both a tri-plane and wire mesh. The tri-plane is a very bright target, and the plot is automatically scaled to the

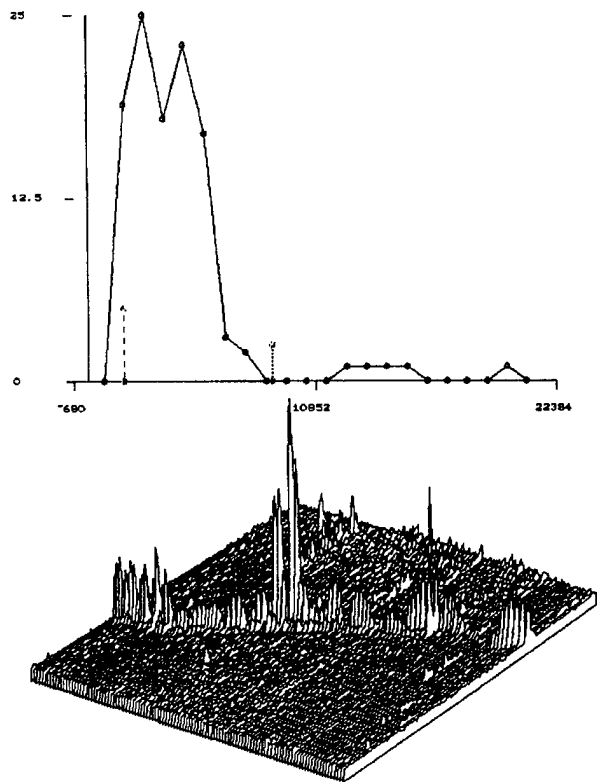


Figure 10. The scattering strength plot of a tri-plane with a wire mesh target towards the back. The tri-plane is the bright line across the plot, which is typical of a point target. The small step at the base of each simple contact is the plate that joined the two halves of the tri-plane and indicates the high range resolution of the system. The wire mesh is more diffuse and much lower in amplitude.

range of that target. In a case like this, the present system assumes that this represents a single target with two scattering clusters.

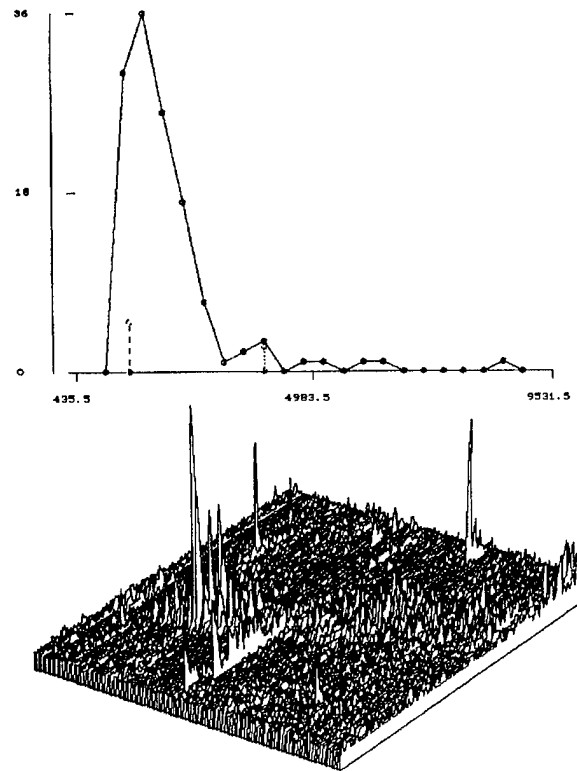


Figure 11. The scattering strength plot of an ammunition box. The echo is more diffuse low in amplitude except at a few aspects.

Some man made targets have a very low scattering strength except at an aspect normal to one of their faces. The ammunition box (Figure 11) is an example of this. Over nearly all aspects the scattering is detectable, but at the same level as many of the natural objects. However, for a few pings the sonar is normal to a side of the ammo box, which gives a very large specular return.

Point targets, such as the tri-planes (Figures 7 and 10) and cinder blocks are examples of small, intense targets that appear to be a point source. Other examples are spheres and vertical cylinders (Figure 12). These targets have rotational symmetry, so that a specular return is obtained at all aspects. These targets tend to have a high number of hits, because their echoes are well above threshold at all angles. The same phenomenon gives them a relatively high mode, and thus a low max/mode ratio.

Low level targets, such as the wire mesh, chain



clump, and metal plates, did not provide any large returns. In the case of the mesh and chain, the objects had no solid surface which could generate a specular return. The plates were laying on the bottom, so that an specular reflections was scattered away from the sonar. Only Rayleigh scattering from the plate edges was available. Thicker plates (> 1 cm.) probably would have caused much brighter reflections.

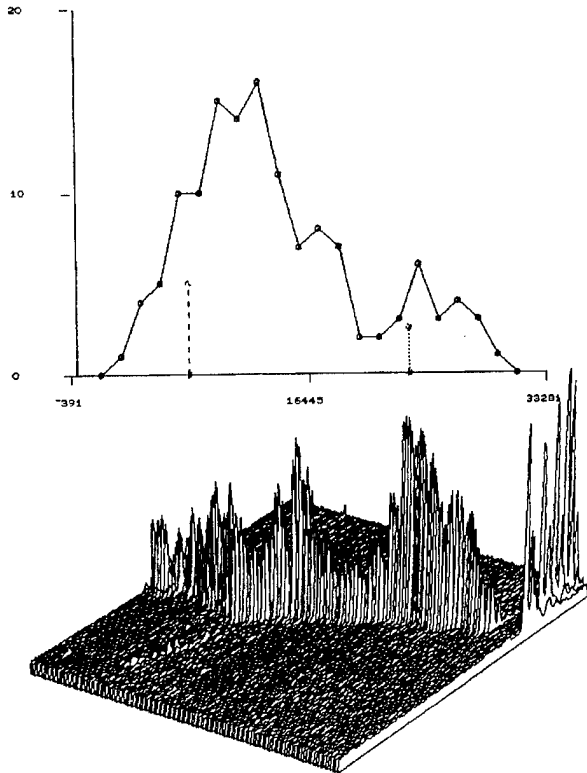


Figure 12. The scattering strength plot of a vertical PVC cylinder. The peaks at the right were noise caused by temporary loss of sync of the signal.

Figure 13 is the target file of the chain clump. It is relatively diffuse and of a low intensity compared to other man made targets. However, it still had characteristics far enough away from natural that it was classified as man made. Figure 14 is the target file of a rock. Unfortunately there were some noise spikes that resulting in a scale factor that makes the rock echo look even lower than it is. Figure 15 is the target file of an aluminum plate. There is enough of a target strength to cross the threshold a few times, but no obviously prominent target. This

was classified as a natural object.

At the beginning of this project we had considered using more sophisticated characteristics such as length, depth, degrees of rotational symmetry, etc.. It was possible in many cases to estimate these features by hand. However, because of the limited amount of data we had, there was no attempt made to do a statistical analysis of these

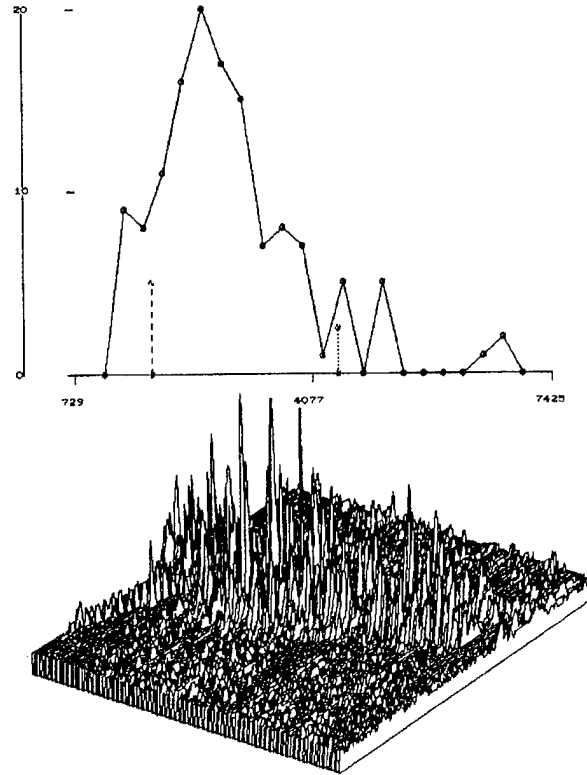


Figure 13. The scattering strength plot of a chain clump. Note that it is a diffuse target with weak highlights.

features. If one were to use this method for classifying particular objects, it should be done with a sufficient number of test targets. However, in our particular case we were trying to make a system that could be used to look for generic man made objects, with the final classification based on manual interpretation of the target files coupled with some *a priori* information about the geometry and structure of the desired target.

#### F. Data Rate Reduction

The MAC has an extremely high data rate. Assuming a 5 knot vehicle speed and 200 yard

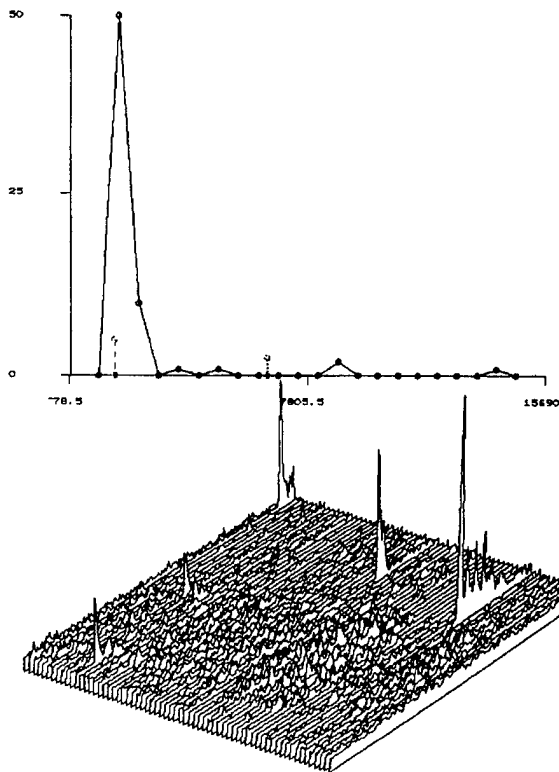


Figure 14. The scattering strength plot of a rock. It is diffuse, and there are no prominent highlights.

swath width, approximately  $2 \times 10^{10}$  digitized data are generated per square nautical mile. The data rate would be more extreme for sonars with more beams used at greater ranges. This is an inconveniently large amount to store and later review. With the present method, most data for a given area of bottom may be dropped as soon as that area passes out of the sonar's beams. Since only target files are kept, the amount of data stored drops considerably. For instance, during the demo tests we saved approximately  $1.2 \times 10^4$  samples per target file. The threshold we used gave us 12 unknown but presumed natural contacts in a 45m by 60m area, which is approximately 23K files per nautical mile. Assuming this situation obtains in a 1 sq mi search area, saving only target files would result in about 360M data points. This is well within the capacity of current disk drives.

In searching for specific targets or target types, it would also be possible to order the detected targets

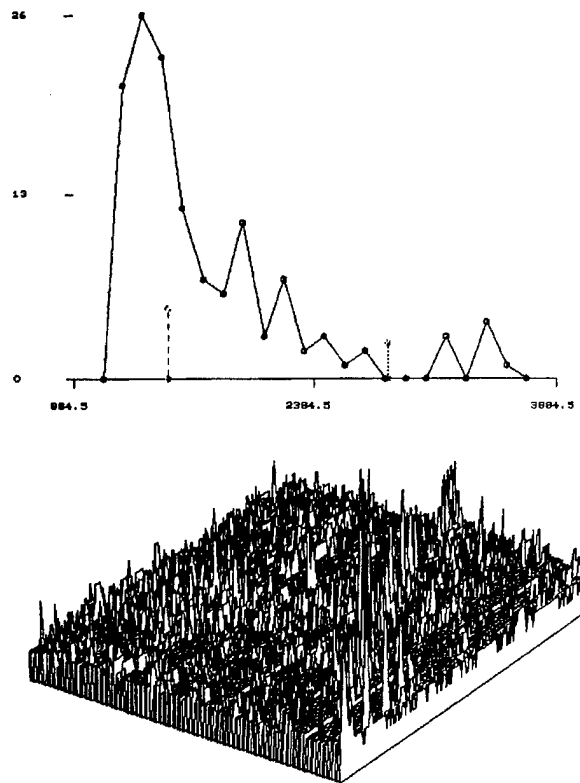


Figure 15 The scattering strength plot of an aluminum plate. This target was no brighter than most natural objects, and had no obvious highlights. It was classified as a natural object.

according to how close each contact was to the expected position of the desired object in feature space. Only the target files considered most likely to be that of the desired object could be saved. One could save only the most likely contacts for a relatively unimportant target or proportionally more for a critical object.

The most parsimonious method would be to save only the features of each contact. This would drop the storage to a trivially small amount that could be stored in RAM memory. This procedure would preserve all the information that we are currently using to identify the target, but would not preserve anything suitable for object-data visualization by the operator. Unless data storage is critical, and until much more is known about the desired contacts, we would not consider the feature-list to be a desirable method.

#### IV. SUMMARY

Sonar data were collected from targets that were rotated in the field of a fixed sonar and from multiple bottom-targets that were ensonified by a mobile, multi-beam sonar as it passed by their position. A bottom-mapping method that analyzed the output of the mutli-beam sonar was developed for detecting bottom-objects and extracting only sonar returns that were relevant to each target. The mapping method demonstrated reliable detection of all prepositioned targets, including small ones, while reducing false-alarms to a minimum. In analyzing the target data, most of the man-made targets were quite distant from the natural objects in feature space. The exceptions were the targets without clear scattering faces such as the wire mesh, chain and plates. These were all detectable, but difficult to distinguish from natural objects. If the system must detect such objects, it will have a fairly high probability of misclassifying a natural object as man made. On the other hand, the system had no problems with the other man made targets and would have detected and classified as man made any mine like objects.

The only natural target that was classified as man made was the medium-sized log. This object had a scattering pattern which appeared much like that of a horizontal cylinder. This is not too surprising, because the log was much like a cylinder. Changing the parameters so that the log was classified as natural would mean misclassifying a large number of man made objects. However, the probability of a log being on the bottom is small enough that is worth taking the risk of a possible misclassification.

#### V. CONCLUSIONS

The system used was not intended for mine hunting, but rather to develop algorithms that could be used in an autonomous system to locate and classify as man-made, arbitrary artificial targets on the bottom. At the outset, we gave some thought to the mine hunting problem, and decided that a desirable sonar for mine detection and classification should have 360° of coverage, a 10 kHz bandwidth,

and roughly 80 kHz center frequency. Since that time, the Applied Research Laboratory at the University of Texas has built the AN/WQX-2 swimmer detection sonar for the Shipboard Physical Security Program. The AN/WQX-2 has the desired coverage and bandwidth, and has a center frequency of 68 kHz. Since it was intended to be suspended on a davit from a ship and operate in high currents, it is designed to be towed at up 2.5 kts. Three of these units have been purchased by the Navy. One has been in continuous use at SUBASE Bangor as part of the Waterside Security System, but the other two are not yet committed.

The sonar could be operated from a small craft of 35' in length or greater that had AC power, an enclosed cabin, a davit/winch capable of handling 1000 lbs., and the ability to maneuver and maintain stability at 2 kts. For low speed operation as a mine hunting sonar, the AN/WQX-2 would require no modifications other than an addition of a mass memory board and an additional processor board. More extensive mechanical modifications would be required for fairing and the tow bale.

The advantages of this sonar in terms of near term development and early IOC are important. Since the hardware needed to collect data for software development already exists, software and algorithm development could begin almost immediately. Upon completion of the software development, a mine hunting system could be tested and delivered to the fleet without any further hardware development.

#### Acknowledgments:

The authors thank B. Matsuyama, T. Pastore, and M. Walder of the former NRaD Hawaii Detachment for their invaluable contributions to the development of the hardware and the collection of data described in this report.

# A Neural Network Approach to the Detection of Buried Objects in Seafloors

Raj Mitra

Applied Research Laboratory  
The Pennsylvania State University  
Communications Department  
P.O. Box 30  
State College, PA 16804

**Abstract** - In this paper, we discuss a technique for detecting conductivity anomalies in sediments, e.g., a buried object in sedimentary layers under sea water, by using the neural network approach. The electric field values are used as the inputs to the neural network and the associated conductivities are treated as the targets. The neural network is then trained to associate these conductivities and field values. We demonstrate that a trained neural network can be used to estimate the conductivity of new objects that were not employed originally to train the network.

## 1. INTRODUCTION

One approach to underwater mine detection is to image objects with anomalous conductivities, located in layers of sediments under sea water. The imaging may be carried out via an inverse scattering scheme involving the collection of low frequency electromagnetic field data on the surface of the sea floor. It is necessary to probe the sediment with low frequencies in order that the electromagnetic wave of a dipole source (electric or magnetic), which is typically placed a few meters below the sea surface, can reach the sea floor. This is because the average conductivity of sea water is 4.5 S/m and the skin depth becomes rapidly small with increasing frequency. In this paper, we simulate the nature of the low frequency electromagnetic field at the surface of the sea floor by using a technique similar to that in Wang and Hohmann [1] for conductors in earth. However, the present case presents the challenge of propagating dipole fields in sea water, which is orders of magnitude higher in conductivity in comparison to that of the earth. The electromagnetic simulation is carried out by using a general-purpose solver of Maxwell's equations in the time domain, which is based upon the application of the Finite-Difference Time-Domain (FDTD) algorithm first introduced by Yee [2] and subsequently improved over the following decades by many workers. In its conventional form, FDTD is typically employed for the solution of electromagnetic field problems at high frequencies because the number of time steps required for the time-iteration process to converge becomes prohibitively large as the frequency of interest becomes low. However, it is shown in this work that by treating the displacement term in Maxwell's equation in a special way,

the above-mentioned problem can be circumvented and the computational efficiency can be enhanced by several orders of magnitude.

We also present a technique for detecting conductivity anomalies in sediments, e.g., a buried object in sedimentary layers under sea water, by using the neural network approach. The electric field values are used as the inputs to the neural network and the associated conductivities are used as the targets. The neural network is then trained to associate these conductivities and field values. It is shown in this paper that a trained neural network can be used to estimate the conductivity of new objects that have not been employed previously to train the network.

## 2. THE FDTD NUMERICAL MODELING

We begin with a summary of the conventional computational procedure followed in FDTD numerical modeling. We point out that the conventional FDTD approach for low-frequency scattering is inaccurate because the truncation of the computational space with absorbing boundary walls does not work well when the dimensions of the computational volume are only a small fraction of the wavelengths involved. To alleviate this problem, we simulate the reflectionless walls by means of a combination of perfect electric conductor (PEC) and perfect magnetic conductor (PMC) walls, used in two separate runs, and average the two results to cancel the first-order reflections. We also point out the importance of interpolating adjacent field samples to obtain the field values at the desired spatial coordinates in the lossy computational space.

### 2.1 The Conventional FDTD

We now summarize the conventional FDTD technique as follows:

1. Fill the computational space as shown in Fig. 1 with Yee's cells [2].
2. Truncate the computational space with reflectionless walls.
3. Place structure to be analyzed in the computational volume.

4. Excite the structure with a time-domain Gaussian pulse whose width is chosen to cover the frequency bandwidth of interest.
5. Observe the transient wave form in the time-domain at a proper location.
6. Compute the field distribution at the frequency of interest by using Fourier transform.

Normally, the above procedure works well when the reflectionless walls in Step 2 are absorbing boundary condition (ABC) (MUR [3]) surfaces, and the dimensions of the computational space are several wavelengths at the minimum. For low-frequency applications, however, the ABC walls behave like PMC walls and the FDTD simulation gives the incorrect field distribution as is apparent from a comparison with the analytical results. The remedy for this difficulty is to use both of the PEC and PMC walls in the manner described in the next section.

## 2.2 The Low-Frequency Computational Procedure

In this section a computational procedure that is suitable for low-frequency scattering application in FDTD numerical modeling is described in detail.

*The mixed and reversely mixed PEC and PMC boundary walls.* Consider the computational space shown in Fig. 2. A dipole source is placed in the center of the space which is enclosed with perfect electric conductor (PEC) walls and perfect magnetic conductor (PMC) walls. The arrangement of the PEC and PMC for opposite walls has the desirable effect of canceling the primary images in these walls. The secondary images are negligible since the medium is lossy and the images are located farther out so their contributions to the field within the computational volume are attenuated completely. Obviously, for this scheme to work well, the computational space obviously must be large although the structure, e.g., buried object, may be small. For smaller computational volume, the computed field distribution appears to be asymmetric due to the different boundary conditions imposed on opposite walls. In such cases, we substitute the PEC walls for the PMC walls and the PMC walls for the PEC walls in the manner shown in Fig. 3 and repeat the computation of the field distribution in the new computational volume. The new result appears to be asymmetric too, but in a reversed manner. However, an average of the two computed results give the correct and symmetrical field distribution.

*Speeding the solution of the diffusion equation using the wave equation solver.* In FDTD the Maxwell's differential equations are solved by using the central finite differencing technique, and the time-domain version of the curl equation of the magnetic field is

$$\nabla \times \bar{H} = \sigma \bar{E} + \epsilon_r \epsilon_0 \frac{\partial \bar{E}}{\partial t} \quad (1)$$

At low frequencies, the displacement current is orders of magnitude smaller than the conduction current in (1). Therefore, the quasi-static approach is valid and (1) becomes

$$\nabla \times \bar{H} = \sigma \bar{E} \quad (2)$$

which is the Ampere's law. The direct implementation of the FDTD using (1) or (2) together with Faraday's law, i.e., the Maxwell's curl of E equation

$$\nabla \times \bar{E} = -\mu \frac{\partial \bar{H}}{\partial t} \quad (3)$$

requires a very long time to run when  $\sigma$  is nonzero. To speed up the process, the parameter  $\epsilon_r$  in (1) is increased to a value of  $4 \times 10^6$ , which is permissible because (2) is still a good approximation to (1) in the frequency range of interest. But, by doing so, the computer run time is reduced from more than 20 days down to about 15 minutes without compromising the accuracy of the results.

## 3. COMPUTATIONAL RESULTS

We consider a scenario where a constant current dipole source, operating at an extremely low frequency, such as 1 Hz, is employed to excite the sea floor, and sensors distributed along a straight line on the sea floor are used to collect data that are processed to characterize information about the buried objects, e.g., their conductivities. An investigation of the forward scattering problem shows that although certain components of the electromagnetic field configuration at the sea bottom exhibit a definite dependency on the conductivity of the objects located just below the surface of the sea floor, this dependency is quite non-linear. In this paper, we explore the possibility of estimating the conductivity of the buried object by using a non-linear mapping technique that utilizes the neural network approach. We show that by training the neural network with a set of field values and their associated conductivities, the neural network can be trained to estimate the conductivity of a new object of the same shape and located at the same depth below the surface of the sea floor.

We illustrate the application of the neural network approach [4] by considering a specific case in which the object is a prism of variable conductivity ( $\sigma$ ), which is buried in the top layer of the sedimentary layers under sea water. We want to estimate the conductivity of the buried prism by sensing the electric field just above the sedimentary layers. Let the electric dipole in sea water, oriented parallel to the x-direction as shown in Fig. 1, be excited with a 1A current at 1 Hz, and let the sensors be located along the x-direction as indicated in the same figure.

The z-component of the electric field for  $\sigma$  greater than that of the host layer is plotted in Fig. 2, which clearly shows how the electric dipole field is modified due to the presence of an object with a conductivity anomaly of higher conductivities. We observe from this figure that the field variation is localized directly above the buried object and this, in turn, allows us to detect and pinpoint the location of the object. Using this feature of the  $E_z$  variation with  $\sigma$ , a neural network is designed to estimate the conductivity of the buried prism, and it is shown in this paper how this network is trained first and used later to estimate the new conductivity contrasts with reasonable accuracies when presented with the new field values.

See Page 7-86

#### REFERENCES

- [1] T. Wang and G. W. Hohmann, "A finite difference, time-domain solution for three-dimensional electromagnetic modeling," *Geophysics*, Vol. 58, No. 6, pp. 797-809, June 1993.
- [2] K. S. Yee, "Numerical solution of initial boundary value problems involving Maxwell's equations in isotropic media," *IEEE Trans. Antennas Propagat.*, vol. AP-14, pp. 302-307, May 1996.
- [3] G. Mur, "Absorbing boundary conditions for the finite-difference approximation of the time-domain electromagnetic field equations," *IEEE Trans. Electromagn. Compat.*, vol. EMC-23, pp. 377-382, Nov. 1981.
- [4] H. Demuth, and M. Beale, *Neural Network Toolbox User's Guide for Use with MATLAB*, The Math Works Inc., Natick, Mass, Jan. 1994.

Fig. 2.  $E_z$  for  $\sigma$  greater than that of the layer.

See Page 7-86

Fig. 1. Geometry of the buried prism problem.

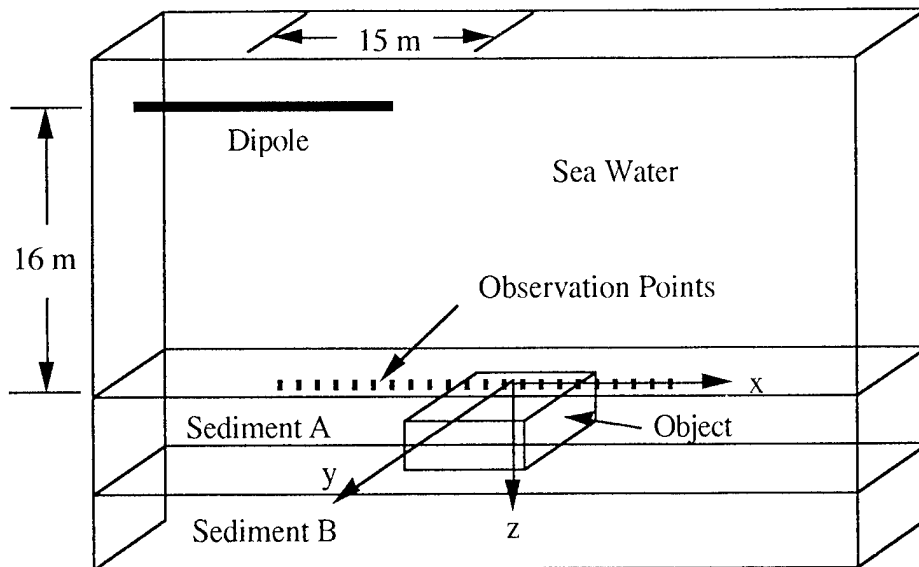


Fig. 1. Geometry of the buried prism problem.

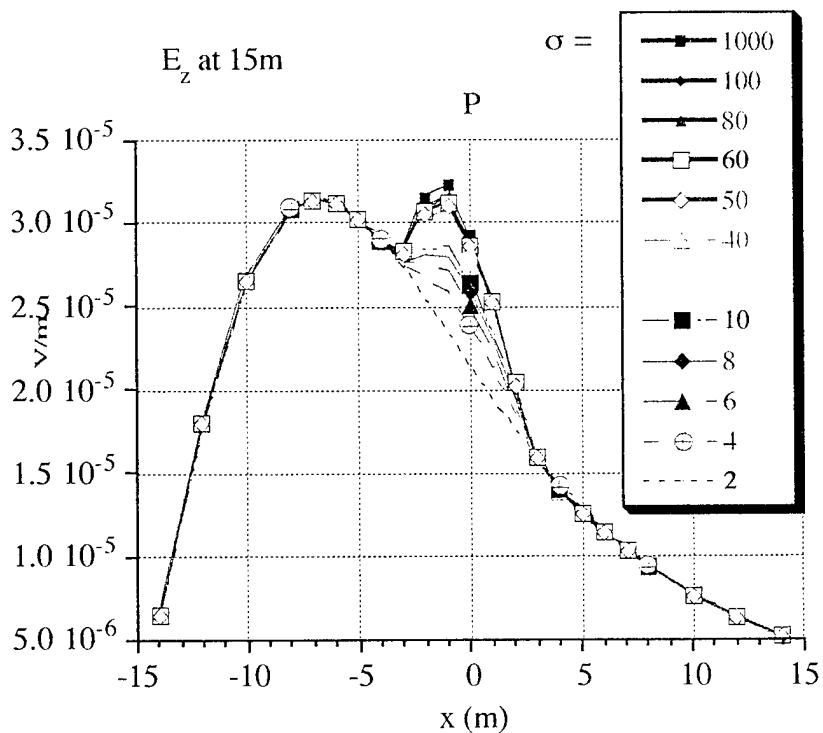


Fig. 2.  $E_z$  for  $\sigma$  greater than that of the layer.

# **Free Surface Slope Signature of Moored Mines in a Current - Experimental Results**

**P.M. Smith**

**Remote Sensing Division  
Naval Research Laboratory**

Interest in the clandestine reconnaissance of beaches, strategic passages, and estuaries, for the presence of submerged moored mines, has motivated the study of the remote sensing of submerged mines by electro-optical (E-O) and microwave means. While (E-O) sensors boast higher resolution and wider swath than microwave sensors, the latter provide a view of the sea surface through clouds, and turbidity is not a factor in microwave detection. E-O sensors, however provide a direct detection of the mine whereas microwave detection must depend on indirect effects of the mine such as a surface wake or a subtle effect on the ambient wave field. This study is directed toward determining the nature of such subtle effects and their detectability.

The free surface of the ocean is affected by the presence of the mine in two ways: directly through vortices shed by the sphere and, indirectly, through the Kelvin wake, a pattern of surface waves generated by the current flowing past the mine, that is not unlike the wake of a ship riding on a free surface. The simplest case to test in a laboratory setting is that of a moored mine in a constant current not under the influence of an ambient swell field.

We use a flume or channel for the test. However, in order to avoid artifact turbulence caused by flow against the flume walls we move the mine rather than fix the mine and move the fluid past the mine. To this end we take advantage of a towing tank facility which was designed to calibrate current meters by mounting them on a tow carriage which moves on rails above the channel. We use this tow carriage as the prime mover for the moored mine by rigging a tow line in an endless loop which spans the length of the flume and completes the loop along the bottom of the tank being attached to a trolley at the bottom as seen in figure 1. The travel distance of the trolley is 50 m. A test section, located at the mid-travel point, supports a laser slope gauge and a vertical array of three velocity turbulence probes. The laser beam passes through the free surface from below, from a Helium-Neon laser which is positioned on the tank bottom. An x-y position detector, together with an optical system, converts the laser beam deflection to free surface slope. Both the turbulence probes and the slope gauge can be repositioned at various locations across the channel. The tank is about 4m wide and 4m deep.



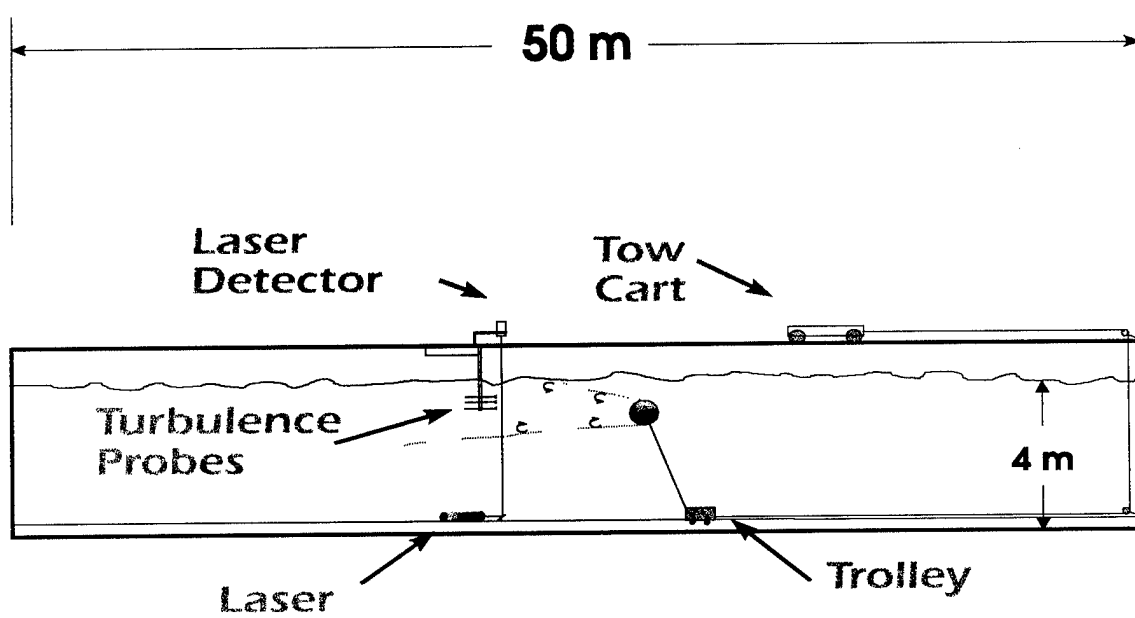


FIGURE 1  
Schematic of tow tank.

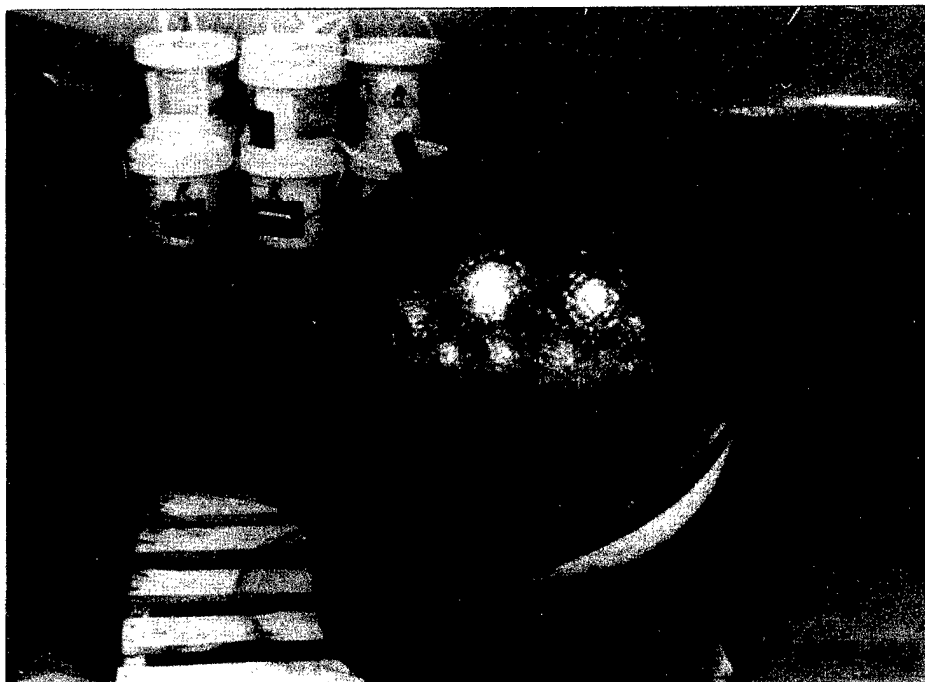


FIGURE 2  
30" mine casing.

Two mine sizes - 30" and 20", diameter - were towed at two different speeds - .75 m/s (1.5 kts) and 1.5 m/s (3 kts). Several depths were used. A photo of the 30" mine appears in figure 2

The relevant Reynolds and Froude numbers for some of the test parameters are shown in Tables I and II, respectively.

Re	Tow Velocity (m/s)	Mine Diameter (m)
$5.7 \times 10^5$	.75 (1.5 kts)	.76 (30")
$1.7 \times 10^6$	1.5 (3 kts)	.76
$3.8 \times 10^5$	.75	.51 (20")
$7.6 \times 10^5$	1.5	.51

Table I  
Reynolds numbers (Re) for the two mines, using mine diameter as the length scale.

Fr	Tow Velocity (m/s)	Depth (m)
.44	.75 (1.5 kts)	.30
.88	1.5 (3 kts)	.30
.31	.75	.60
.62	1.5	.60

Table II  
Froude number (Fr) scaling using the depth to the top of the mine as the scaling distance.

The Reynolds numbers in Table I, hover close to what is often called the critical Reynolds number - that velocity at which the boundary layer adjacent to the sphere transitions from laminar to fully turbulent flow. This number is  $5 \times 10^5$  for a sphere. If the sphere is free to move, an asymmetry may ensue whereby one side of the sphere is laminar and the other turbulent. Such an imbalance produces lateral forces on the sphere. In fact, the mines were observed to swing laterally back and forth during the tow about (1) mine diameter - perhaps in response to such a stress imbalance.

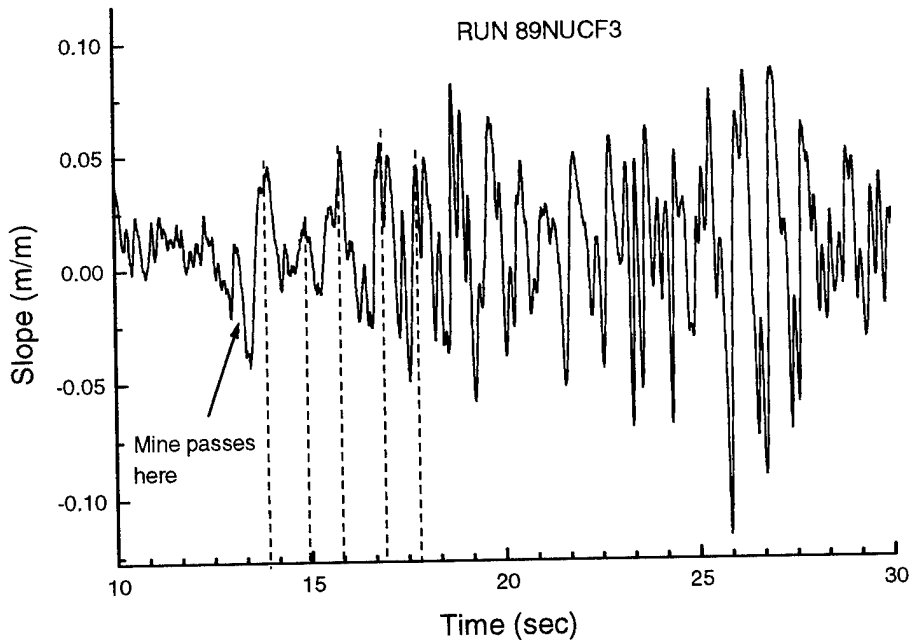


Figure 3

Time series of along-tank component of free surface slope. Conditions are: no wind, mine depth = 60 cm, 30" mine, current = 1.5 m/s.

Figure 3 is a time series of surface slope and is typical, in character, of most of the tows. In particular, a minimum in the wave envelope occurs after about 8 or 9 wave crests, followed by a pronounced maximum in slope. The waves have a period of about 1.2 seconds. If we assume that these waves are fixed in a frame-of-reference moving with the mine, their phase speed must be 1.5 m/s. The formula for the phase speed,  $c$ , of a deep water wave is:

$$c = \sqrt{\frac{g}{k}},$$

where  $g = 9.8 \text{ m/s}^2$  and  $k$  is the wave number. Solving for  $k(\lambda)$ , we get:

$$\begin{aligned} \lambda &= 2\pi c^2 / g \\ &= 1.44 \text{ m.} \end{aligned}$$

A 1.4 m wave moving at the tow velocity of 1.5 m/s would appear to have period of,

$$T = \frac{1.44}{1.5} = .96 \text{ sec}$$

This is in rough agreement with the observed period of 1.2 seconds. The mine wake, then, creates a gravity wave which, on the center line of the water, can be approximated by a deep water wave whose phase speed equals the current velocity and whose wavelength satisfies the deep water dispersion relation. This is the character of the well-known Kelvin wake. The second maximum in the wave slope signal is thought to be an artifact of wave energy reflecting back into the center of the tank from the walls of the tank. This energy would normally radiate away from the wake centerline.

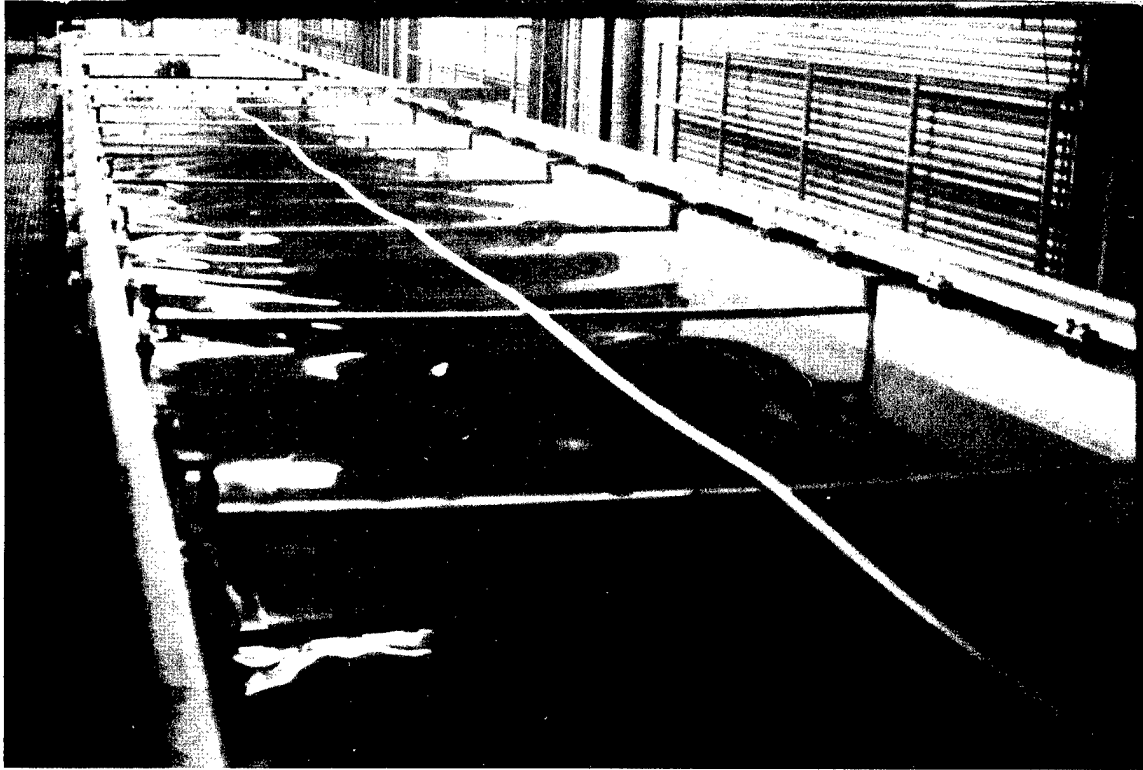


FIGURE 4

Train of Kelvin waves generated by advancing submerged mine. Note that neither the leading wave nor the wave following reaches the walls of the tank.

Figure 4 is a photograph of the train of Kelvin Waves just trailing the mine G.X. Wu (1995) provides an analytic description of the wake of an advancing, submerged sphere in a finite depth fluid. Wu (as do others) treats the solution in two parts: a) the near field solution which satisfies the boundary conditions of an inviscid fluid at the sphere boundary and at the free surface and b) the far field solution which satisfies the free surface conditions and the radiation condition. Figure 5 shows a plan view of the far field solution for the wave free surface height. The solution resembles that for an underway surface ship. The near field solution (not shown) is valid within a few mine diameters of the mine and is not wave-like, but is anti-symmetric about a vertical plane passing through the sphere center and extending across the tank. It is this solution that is characterized by the hump in advance of the mine and the trough behind the mine.

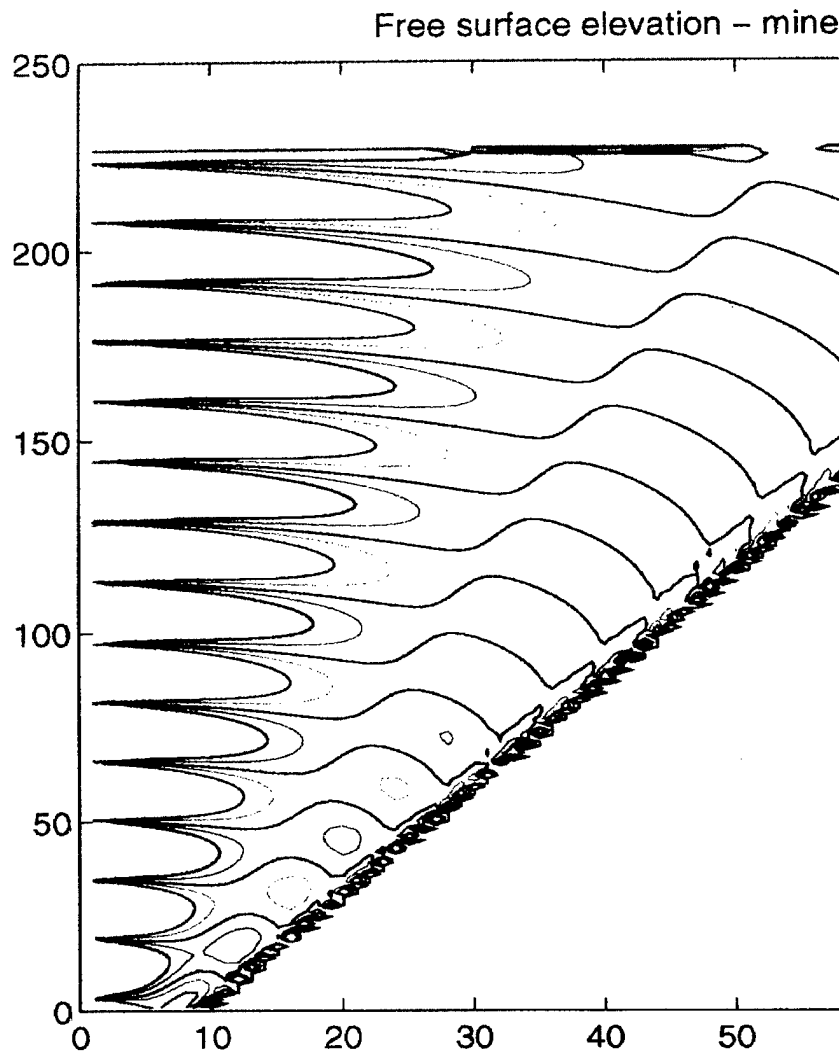


FIGURE 5

Elevation contours of the far field solution to the mine wake after G.X. Wu (1995)

Most tows produced a well-behaved wake with the exception of the shallow (depth=30 cm), high speed ( $v=1.5$  m/s) tow of the 30" mine. Under these conditions a super-critical Froude number effect ensued with the first wave crest continually spilling during the tow (See figure 5). The mine never broached the surface during this time. During a shallow, high speed tow of the 20" sphere, no such spilling occurred. The spilling wave (could also be considered a bore) is therefore not only a function of the Froude number (which is independent of the mine diameter) but may also be a function of the Reynold's number. Both mine shapes show sub-critical Froude numbers in Table II.

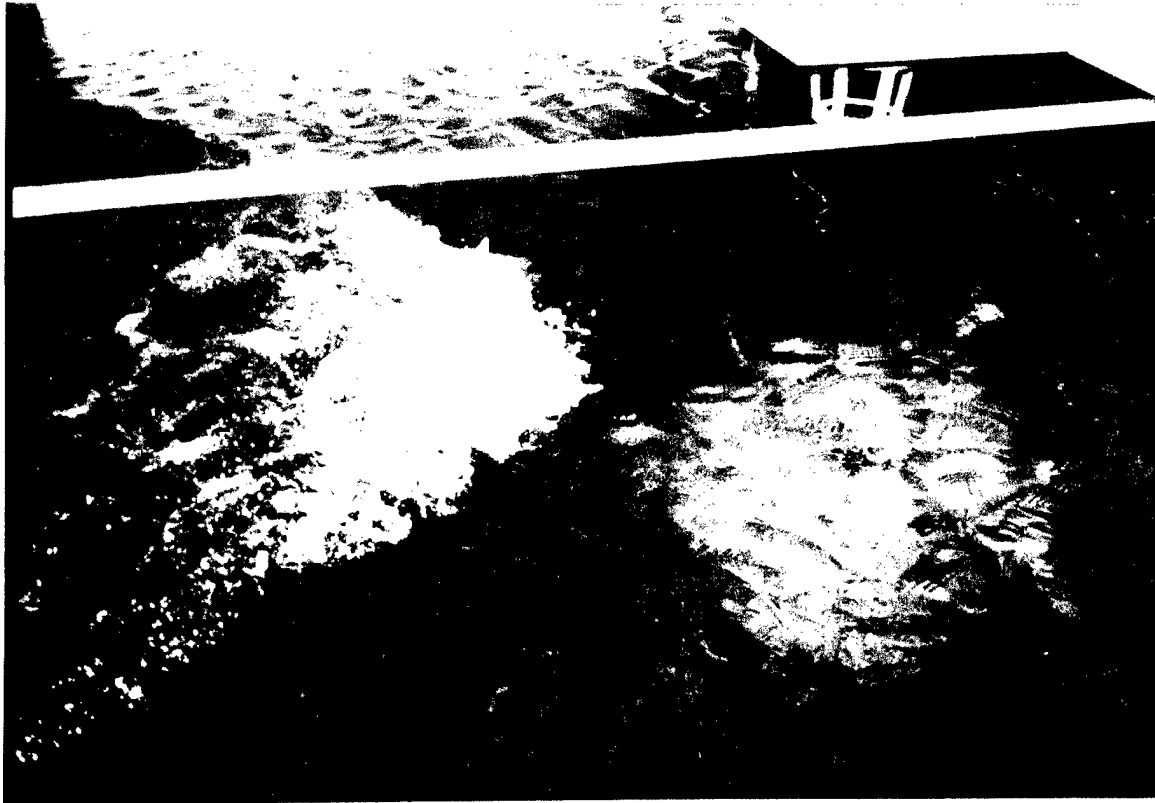


Figure 6  
Wave breaking behind 30" mine with 1.5 m/s current flowing.

During each tow, several vortices could be seen rising to the surface as evidenced by a "boil" or smooth path on the surface. One such vortex advected through the turbulence probes and can be seen in figure 6 as an anomaly in the velocity. The mine passes the instruments at about  $t=20$  seconds, wherein the orbital velocities associated with the Kelvin wave ensue. However, at about  $t = 38$  seconds a vortex appears (a boil was observed at the surface) as is evidenced by the energetic vertical velocity components as well as a strong shear in the across-tank component ( $u$ ) of velocity. The associated velocities easily exceed the wave-related velocities and represent the largest form of turbulence present. The background turbulent fluctuations appear to be of the order of only 1 to 2 cm/sec.

Figure 8 shows the damping effect of this vortex on the surface waves - especially at  $t > 41$  seconds.

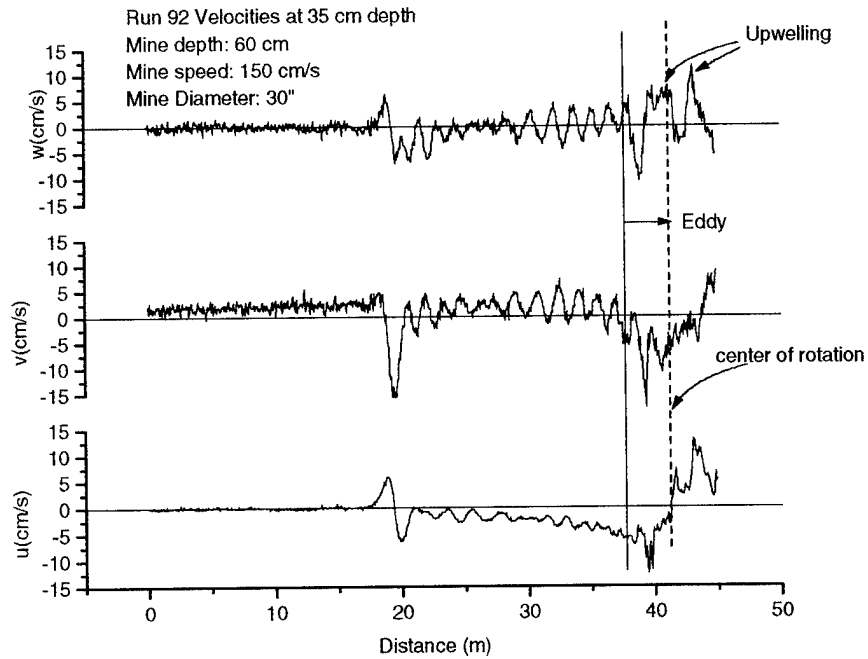


Figure 7

Three components of velocity measured above the mine showing the advection of a vortex into the probe array. Eddy velocities are large compared to wave orbital velocities.

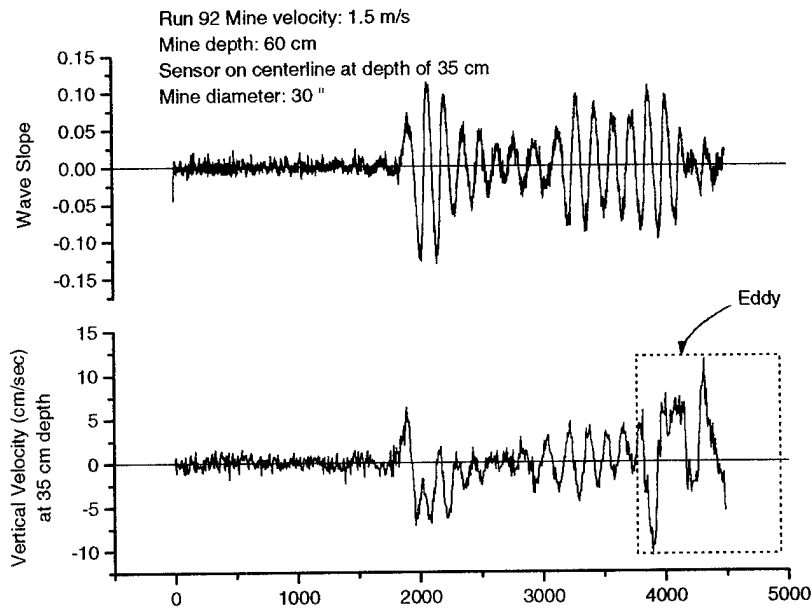


Figure 8

Wave slope signature exhibits severe damping in the presence of eddy.

## Conclusions

Two mechanisms dominated the modulation of the free surface slope by a moored mine in a current: The Kelvin wake, both by its presence and by its effect on the ambient wind wave field; and vortices rising to the surface after having been shed from the boundary layer of the mine. The Kelvin wake may be discernible by remote sensing means in the presence of an ambient wave field due to its coherent structure (see Figure 5) if the appropriate matched filters are applied to the data. The turbulent vortices, on the other hand, are intermittent and highly localized and probably would not submit to detection by automated detection schemes. If the mine is sufficiently close to the surface, large enough in diameter, and if the flow is swift enough, the Kelvin wave will break over the mine. This breaking occurs at a Froude number slightly less than 1. The fact that the occurrence of breaking is dependent on mine size implies that other non-dimensional numbers, such as the Reynolds number, may play a role in prescribing the criteria for breaking.

## References

Wu, G.X., 1995, "Radiation and diffraction by a submerged sphere advancing in water waves of finite depth", Proc. R. Soc. Lond. A, Vol 448, PP 29-54.

## Acknowledgments

This work was supported by the Marine Corps TENCAP Office, LtCol T. Cummins, contracting officer, and by the Office of Naval Research, Mr. J. DeCorpo, contracting officer.





# Seismo-Acoustic Sonar for Buried Object Detection

Thomas G. Muir, D. Eric Smith, and Preston S. Wilson

Applied Research Laboratories  
The University of Texas at Austin  
Austin, TX 78713-8029

**Abstract**--The concept of a seismic sonar for the detection of buried mines and other ordnance is demonstrated. An electromechanical transducer is used to excite Rayleigh waves that travel along the sediment interface. A mine-like target produces Rayleigh wave echoes that are received, processed and displayed. The experimental results are supported by theory developed for vector wave fields with the tensor calculus and matrix algebra. Sonar equation extrapolations are used to assess the potential of the approach. Continuing research topics are suggested.

they range up to several thousand m/sec on interfaces containing hard rock. In unconsolidated sediments, these waves are also highly dispersive with frequency, due to the compaction with depth caused by overburden loading. In general, velocities tend to increase with depth into soils and sediments. Seismic interface waves comprise true vector fields because they can have particle velocities in three dimensions. Rayleigh waves travel in elliptical particle orbits having a vertical and radial component. The vertical component is perpendicular to the propagation path and the radial component is co-linear with it.

## I. INTRODUCTION

The principle of seismic interface wave generation, propagation, and sensing is sketched in Fig. 1 for the case of a Rayleigh wave. A man made source vibrates the ground, generating this wave, which propagates outward and is concentrated at the air-ground interface. The wave exists in both media and is exponentially damped with depth into the ground, where it is predominately a shear wave. With propagation, the Rayleigh wave spreads cylindrically ( $1/\sqrt{r}$  law), and soil friction (i.e., movement between sand grains) provides attenuation, which ranges from a few tenths to several dB per wavelength, depending on bottom type. Hard, consolidated sediments (i.e., sandstone and limestone)

## II. SONAR CONCEPT

The utilization of Rayleigh waves in a sonar context is sketched in Fig. 2. This sketch deliberately shows no platform vehicle and is only intended to illustrate the

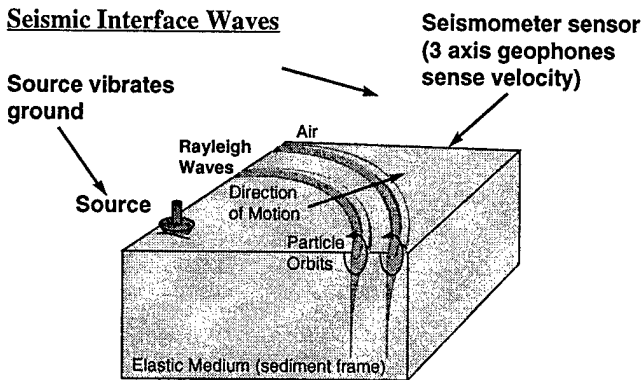


Fig. 1. Generation and propagation of seismo-acoustic interface waves.

have low attenuation while soft, unconsolidated sediments (i.e., beach sand) have higher attenuation. The velocities of interface waves are quite slow in unconsolidated soils and sediments, typically a few hundred meters a second, while

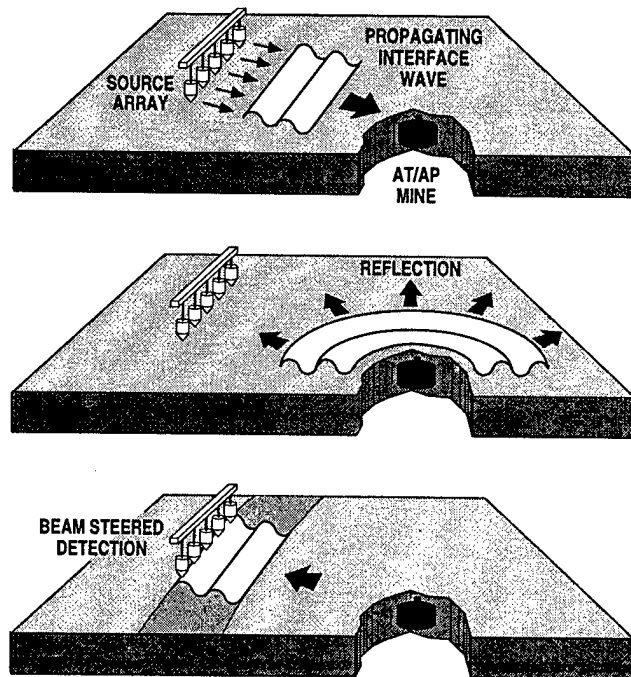


Fig. 2. Concept of the seismic interface wave sonar for mine detection.

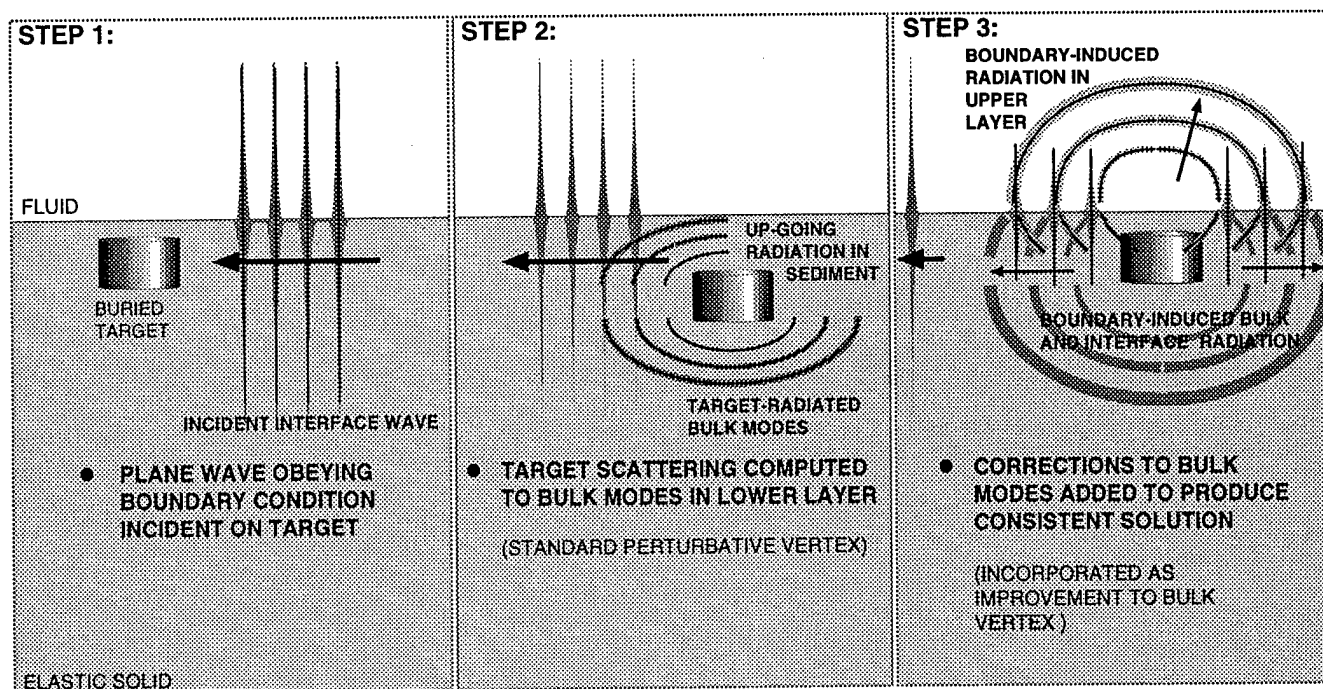


Fig. 3. Key steps in the derivation of theory for seismic interface wave sonar.

general seismic sonar concept. A source array radiates the interface waves along the surface, and an array of seismometers (three axis geophones, which are velocity sensors), is laid out for reception. A recent ARPA, ONR, and NATO demonstration, done by ARL:UT and SACLANTCEN, developed the theory and provided experimental proof of the feasibility of beamforming on seismic interface waves on the sea floor [1]. Since the interface wave velocities are quite low, narrow beams can be developed at low frequencies, (tens to hundreds of Hz) that the medium prefers for seismic propagation. This means that small arrays, a few meters in length, can develop adequate angular resolution for object detection at wavelengths on the order of a meter. Of course, medium heterogeneities can distort propagation paths, reducing the spatial coherence required for beamforming. This will probably limit seismic sonar ranges to distances measured in the tens to hundreds of meters, depending on the medium at hand. Fortunately for the amphibious warfare (AMW) problem, wet beach sand is usually a benign, homogeneous medium at seismo-acoustic sonar frequencies. Because of the exponential damping away from the interface, the Rayleigh wave (and other interface waves) are ideally concentrated in the portion of the ground where buried mines and ordnance exist. This reduces the undesirable scattering and reverberation from environmental features outside this zone.

### III. THEORETICAL MODELING

Because of the contrast of density and rigidity between the heavy, rigid, man made target and the surrounding soil or sediment, the target produces seismo-acoustic echoes that

travel in all directions, in all of the possible propagating modes allowed by the theory of elasticity. A recent theoretical study [2] has produced, from first principles, a model of the seismo-acoustic detection of buried objects returning echoes in the interface wave modes. The model utilizes perturbation methods and is valid for the long wavelength case. The key steps in the derivation are sketched in Fig. 3.

Because of the vector field nature of seismic waves, the seismic target strengths are also vector quantities, of unavoidable complexity [2]. However, it appears that the mass of the buried target is the largest contributor to its seismo-acoustic target strength. The theory shows that in the Rayleigh mode, a target occupying a metric volume of  $(1/2\pi)^3$  with a mass of 5 kg, in an unconsolidated sand with a density of  $2 \text{ g/cm}^3$ , would have a monopole target strength of -30 dB. Scaling with mass  $m$  goes as  $10 \log (m/m_0)$ . Of course, the size and shape of the mine affects the target strength and further theory needs to be developed for the case of targets that are comparable in size to a wavelength.

### IV. SEISMIC SONAR MEASUREMENTS

An experiment and technology demonstration was recently conducted by ARL:UT on the Gulf of Mexico beach of Mustang Island, near Corpus Christi, Texas [3]. A rudimentary, non-real time, seismo-acoustic sonar was constructed from laboratory hardware and software. The measurements were conducted on the foreshore, over a hard, wet, quartz sand sediment of 3-6 deg slope, as shown in Fig. 4.

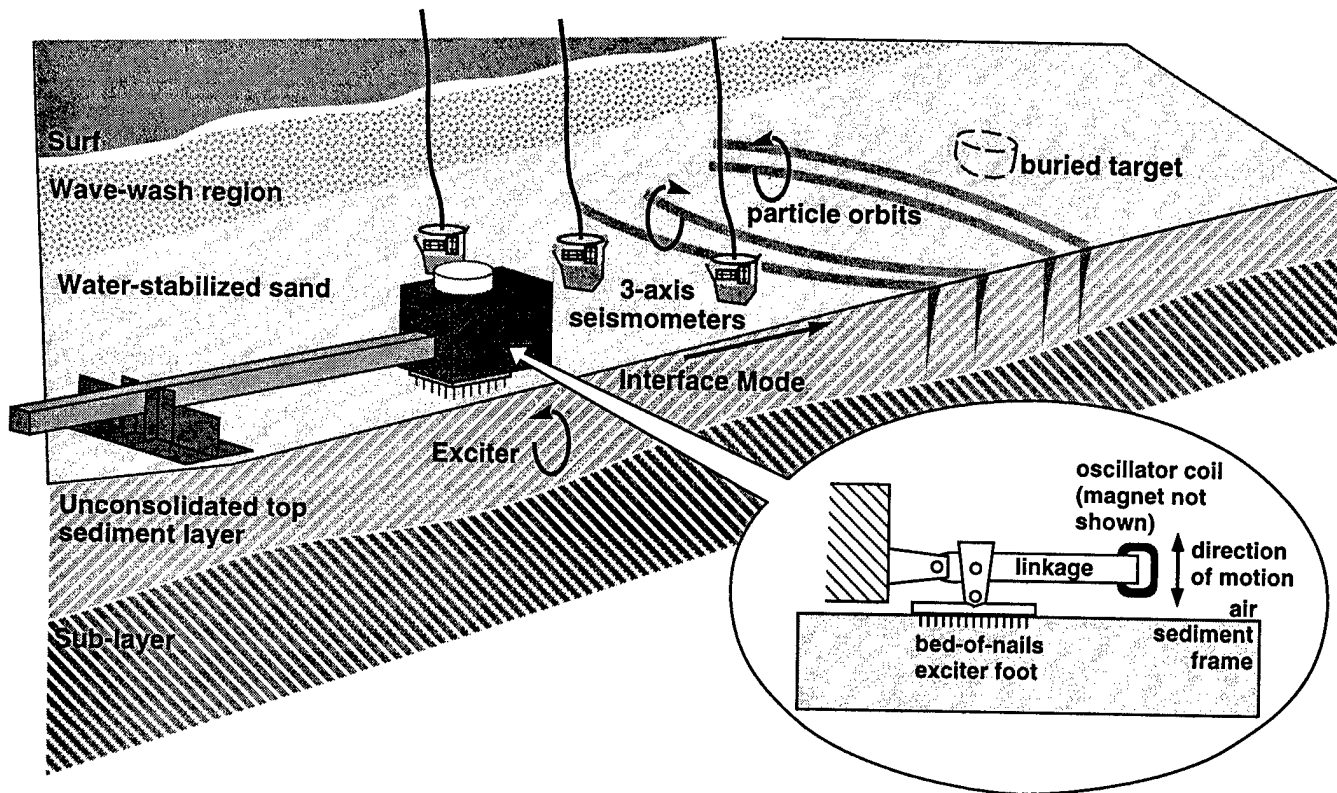


Fig. 4. Seismic sonar experiment on buried object detection.

Ground truth measurements, depicted in Fig. 5, in the form of a Gabor plot, showed the medium to be very dispersive in the 10-40 Hz range, with an optimum frequency for propagation around 22 Hz. The interface waves approached an asymptotic shear velocity of 100 m/sec at frequencies above 50 Hz.

For simplicity, we utilized a source signal consisting of a transient cosine of one cycle, centered at 100 Hz and imparted to the sediment interface as a vertical excitation. The sediment responded with signal elongation, apparent as a "ringing", sending a packet of 1m Rayleigh waves outward along the interface, attenuating at 1 dB/m. The target was a metallic cylinder, weighing 35 kg and buried just beneath the interface. A three element seismometer array was used for reception. The raw, field recorded data showed no echo at the proper range and bearing. Some sophisticated signal processing was required to extract the target echo.

### V. SIGNAL PROCESSING

The vertical source excitation used in these initial experiments unfortunately generated the whole gamut of P and S waves ("P" stands for pressure, "S" for shear). When this happens, the Rayleigh waves of interest are buried in a reverberant background of S body-waves, and to a lesser extent P waves, and it is necessary to remove this noise. This was begun by considering the vector nature of the seismic field. The vertical and radial echo components traveling in a seismo-acoustic Rayleigh wave are naturally 90 deg out of phase, while both P and S body-wave noise-fields are bulk propagating waves and are by definition, "in phase" on both vertical and radial (v and r)

sensors. For the tasks at hand, we developed a technique called vector polarization filtering. The procedure is shown

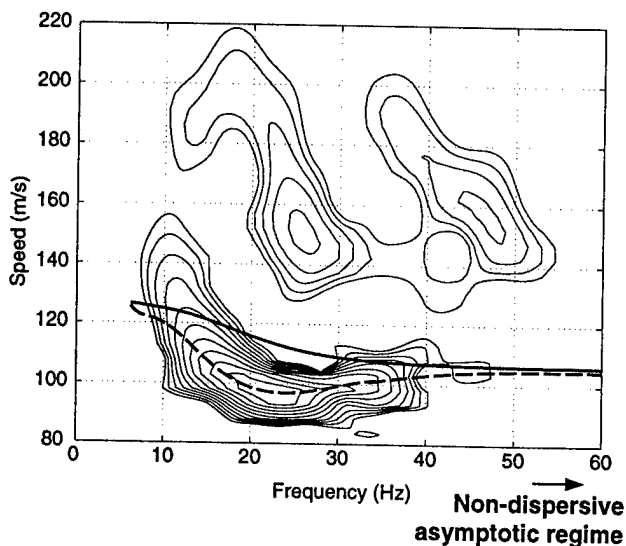


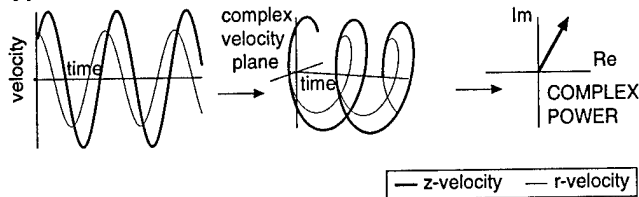
Fig. 5. Gabor plot of ground truth measurement on vertical seismic interface wave velocities in the sediment; depicting intensity contours at 3 dB intervals for a vertical impact source at 100 m range. Key: - - - group velocity, — phase velocity.

in Fig. 6 for the case of P waves, but basically it capitalizes on the phase relationship between  $V_V$  and  $V_R$  signals to compute and "imaginary power", i.e.:

$$\text{Im } P_{rv}(t, \mathbf{x}) = V_V^*(t, \mathbf{x}) \times V_R(t, \mathbf{x})$$

Here  $V(t, \mathbf{x})$  is the complex signal obtained by Hilbert transform from the received (real) geophone signal and  $V^*(t, \mathbf{x})$  is its complex conjugate, as illustrated in Fig. 6.

#### Typical Rayleigh Wave:



#### Typical P-wave noise signal:

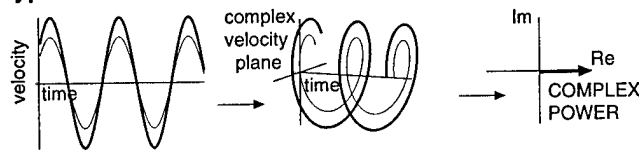


Fig. 6. Principles of vector vs. scalar wave velocity and power relations. The phase relationship between vertical and radial velocity provides the Rayleigh wave with an imaginary component in the complex power, while the P wave noise provides in-phase signals on the vertical and radial sensor, yielding only a real component in complex power processing

The phase relationship between vertical and radial velocity provides the Rayleigh wave with an imaginary component in the complex power, while the body-wave noise provides in-phase signals on the vertical and radial sensors, yielding only a real component in complex power processing.

We then computed the imaginary component of the complex power in the echo signals of each beam. This procedure helps separate the S wave signals from body-wave noise, and the processing improvement is conservatively measured in the tens of decibels, depending on the scenario. For the test at hand, vector polarization filtering reduced the P wave reverberation by 11 dB. Some sample signals for vector polarization processing of a Rayleigh wave are shown in Fig. 7. Note the phase difference between vertical and radial components, and the non-zero imaginary power component.

In this first experiment, the vertical source excitation produced such abundant quantities of P wave and other than Rayleigh wave modes, it was also necessary to employ coherent subtraction to further remove unwanted reverberation. In the test, the time series of the reverberant field was recorded before the test target was buried and then coherently subtracted from that of the echo field, subsequently acquired. Although coherent subtraction is clearly not a signal processing option for a military application, it was useful in this first experiment, and was needed to explore the potential and feasibility of the approach. For the test at hand, the coherent subtraction reduced the reverberation by 13 dB.

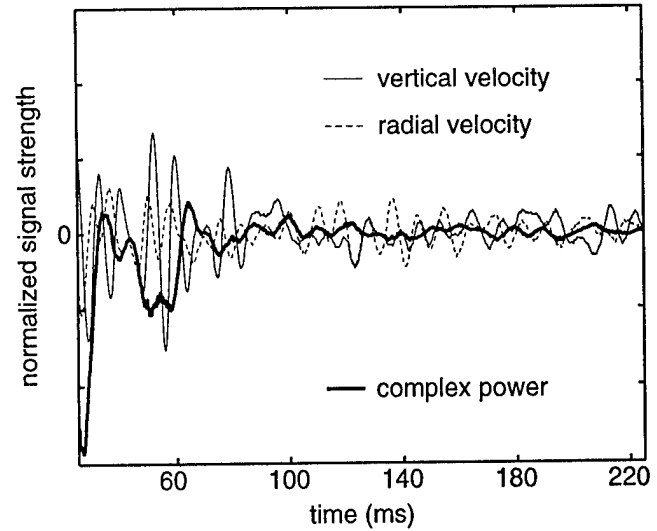


Figure 7. Example of velocity components and complex power in a Rayleigh wave echo timeseries.

## VI. SONAR RESULTS

The processed echo field results, displayed in a traditional sonar/radar Plan Position Indicator (PPI) format are shown in Fig. 8. It can be seen that the seismo-acoustic echo ranging experiment, coupled with the aforementioned signal processing efforts, clearly detected the mine-like test target at its appropriate range and bearing from the experimental sonar, specifically some 3 m in range at 22 deg bearing, all with ample signal to noise to provide a clear display of the target's existence.

Although a proper analysis of these results involves some complex tensor calculus and matrix algebra [2], it is tempting to do some scaling with the sonar equation, so as to explore the engineering potential of this new approach. We begin with the parameters of this first test: a single source with an input, peak electrical power of 315 watts, producing a source level of  $2.61 \times 10^{-4}$  m/sec in the vertical seismic velocity component, a spreading loss of 3 dB per doubling in range, an attenuation of 1 dB/m, a target strength of -21 dB, and 11 dB of vector polarization filter gain and 13 dB of coherent subtraction processing gain, all of which resulted in a sonar range of 3 m in a Corpus Christi beach sand.

The target was deliberately heavy (35 kg) in this first test, so going to a more realistic 5 kg target would reduce its reflectivity by 9 dB, to -30 dB. We also need to dispense with the 13 dB of coherent subtraction processing gain, because this technique cannot be used against live ordnance.

What are the possibilities for improving the other terms in the active sonar equation? First, the input power can certainly be increased, up to the point where the sediment becomes nonlinear and liquefies. This is dependent on the design of the transducer foot, or coupler to the sediment, but a conservative estimate is an order of magnitude in input power for each source. A source array should certainly be utilized, and its size is limited by the size of the sonar vehicle platform. For a tank sized vehicle, a source array of 5 m length is not unreasonable. At half wavelength spacing,

## VII. CONCLUSIONS AND RECOMMENDATIONS

Considering the complexity of micro seismology, the difficulty of the target physics, and the non trivial nature of the signal processing, we were actually quite surprised with this very positive theoretical and experimental development demonstration, which was conducted under conditions of avowed skepticism of all parties connected with the research. However, we are clearly aware of certain limitations which need to be overcome before this approach becomes useful in AMW and/or humanitarian de-mining operations.

Certain key issues identified in this first demonstration of seismo-acoustic sonar for mine detection need to be solved before the approach will have sufficient credibility to justify real system development. For example, the need for coherent subtraction in signal processing has to be eliminated. This and other R&D issues need to be addressed that will put the technology on a sound footing for advanced research demonstrations.

The issues include:

- Development of sources for discrete mode excitation of interface wave modes.
- Development of techniques for discrete mode reception.
- Adaptive methods for excitation and reception of optimal modes.
- Measurement, analysis and utilization of real mine target strengths.
- Incorporation of cetacean sonar protocols and signal physics.
- Re-examination of vector signal processing technology, developed to date.
- Experimental demonstrations and analyses pertinent to these efforts.

The discrete mode source will drive the sediments and soils in the unique particle velocity format required for different seismic interface modes, i.e., for Rayleigh waves, it will drive the ground in elliptical orbits. In so doing, unwanted P waves and other reverberation contributors will be eliminated at the source, enhancing target detection. A measure of discrete mode reception can be achieved by matching the sensor field to the desired mode, in a form of matched field processing. Due to natural difficulties, it will not be a 100% accomplishment, but nonetheless, will significantly reduce noise and reverberation. These mode selection procedures need to be tuned to the medium in an adaptive manner, on site, in real time, and this can be done with feedback control and control systems technology.

It is very important to measure the seismic target strength of representative mine types so that research can proceed with realistic parameter estimations. These devices, loaded with inert explosive materials, can be deployed in a "back yard" testbed for echo signature characterization.

The only sonar system in the world that is successful against buried targets belongs to the cetaceans. Ongoing ONR research at ARL:UT, Texas A&M, and NRaD, seeks to discover their secrets for buried mine detection. Measurements are being made on instrumented animals performing detection work on instrumented buried objects, and the results are being analyzed to determine their signal

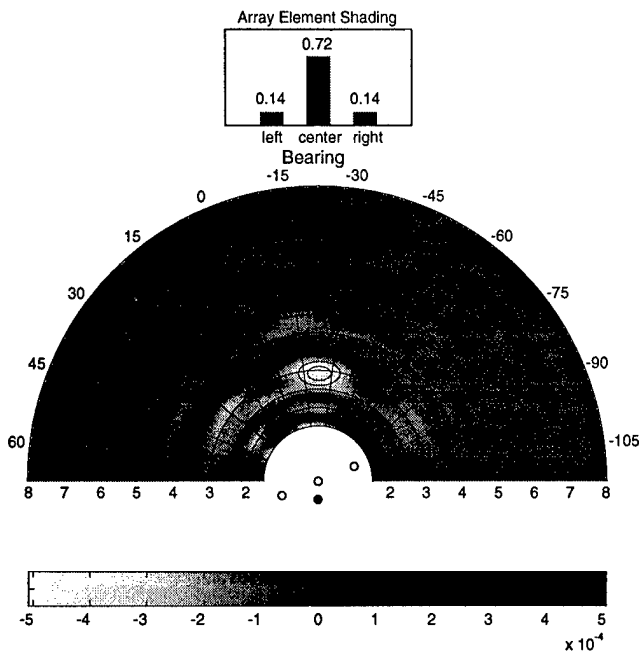


Fig. 8. Example of a sonar PPI plot produced from measurements taken with target buried at 3 m range and -22.5 deg bearing, after coherent subtraction of backgrounds measured without target. Element shadings are also shown.

a 10 element array could be realized, which combined with a tenfold power increase per element, would provide an increase in source strength of 20 dB.

Considerable reverberation suppression could be achieved by utilizing a two degree of freedom transducer, to selectively excite whatever seismic interface wave is desired. For the Rayleigh wave, a retrograde elliptical orbit would be imparted to the transducer foot at the sediment interface, for preferential excitation. Considering the partition of energy in the dozen or so of the possible seismo-acoustic modes, and relying on past experience in selective mode excitation, an improvement of 12 to 18 dB should reasonably be achieved.

With only these improvements (which would be augmented by others, discussed subsequently), and with the necessary downsizing in target strength and coherent subtractive processing gain, we would realize a net increase in figure of merit of 13 dB. For propagation in the Corpus Christi beach example, the sonar range would then be increased from 3 m to 6 m. Although this may seem like a small range for a sonar, it is considerably longer than that of other sensors capable of detecting an amphibious mine buried in beach sediments.

The ultimate range capability of the seismic sonar would be limited by the spatial coherence of interface waves propagating in natural, heterogeneous sediments. Prior, offshore measurements of this parameter have yielded coherence lengths measured in the tens to hundreds of meters. False targets will of course be a problem with seismic sonar and for any sonar operating in sediments and soils.

processing protocols. Results that will be obtained in the work outlined in the preceding paragraphs will undoubtedly affect human engineered protocols for vector signal processing, opening new avenues for its utilization. Accordingly, these procedures need to be re-examined and improved for the maximum processing gain.

Finally, continued research, coupled to demonstrations is, of course, essential to delineate the potential of seismic sonar.

### VIII. ACKNOWLEDGEMENTS

This work was supported by the Independent Research and Development Program at Applied Research Laboratories, The University of Texas at Austin; the Office of Naval Research, Ocean Acoustics Program; and the Advanced Research Projects Agency, Tactical Technology Office.

### REFERENCES

- [1] J.A. TenCate, T.G. Muir, A. Caiti, A. Kristensen, J.F. Manning, J.A. Shooter, R.A. Koch, and E. Michelozzi, "Beamforming on seismic interface waves with an array of geophones on the shallow sea floor," *IEEE J. Ocean. Engr.*, **20**, 1-11 (1995).
- [2] D.E. Smith, "Scattering of interface waves from pointlike obstacles," submitted to *J. Acoust. Soc. Am.*, October 1996.
- [3] D.E. Smith, P.S. Wilson, F. Bacon, J. Behrens, J. Manning and T.G. Muir, "Measurement and location of interface wave reflections from a buried target," submitted to *J. Acoust. Soc. Am.*, October 1996.

**PORTABLE TURNKEY UXO DETECTION SYSTEM**  
**High Quality Data Acquisition→ Accurate Navigation→ Data Analysis**

Author: Mr. Gerhard Vallon  
Co Author: Mr. Okkar Dietz  
VALLON GmbH  
Im Grund 3  
D-72800 Eningen, FR GERMANY  
Tel: 011-49-7121-98550  
Fax: 011-49-7121-83643

USA Contact: Mr. Ronald Hitchler  
Security Search Product Sales  
7 Amaranth Drive  
Littleton, Colorado 80127-2611  
Tel / Fax: 303-933 7955

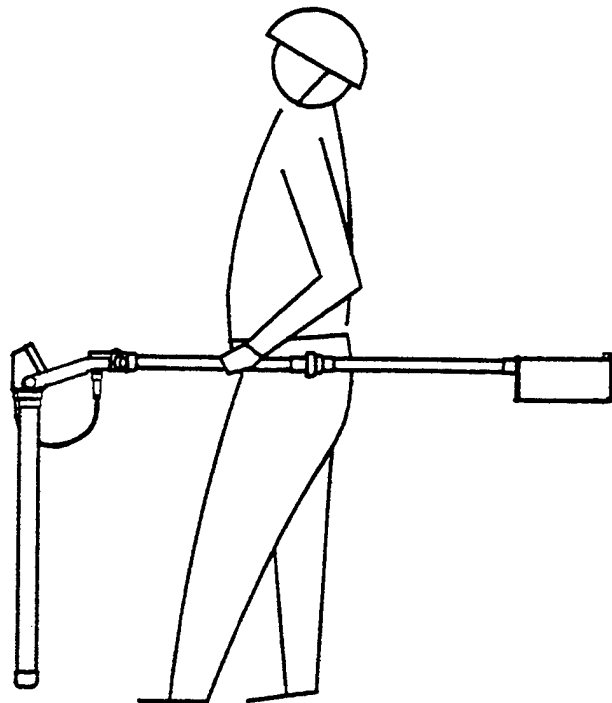
**INTRODUCTION**

After many years and several generations of product development advancements, the company Vallon GmbH has responded to the market needs of the UXO user community with a fully integrated Man-portable Ordnance Locator. Reality aspects seek user friendly equipment which are cost effective (survey time + reliable data processing), to the OEW operator and provide qualified data which meet Government standards.

Equipped with proven detection technologies along with current survey and software techniques, such a system will work effectively today and into the future. The Vallon Ordnance Locator System has been designed to accept further technical improvements as the needs and components become available.

**SYSTEM INTEGRATION**

For several decades buried UXO's have been successfully located by means of portable magnetometer instruments (i.e. Cesium and Fluxgate Magnetometers). Specialty expertise has been gained in areas such as Germany from extensive UXO detection requirements since the conclusion of WWII (many UXO's from this period are still detected to date). Fluxgate gradiometers have been proven to be highly accurate. Especially where high concentrations of UXO are found and in urban areas with ambient problematic conditions.



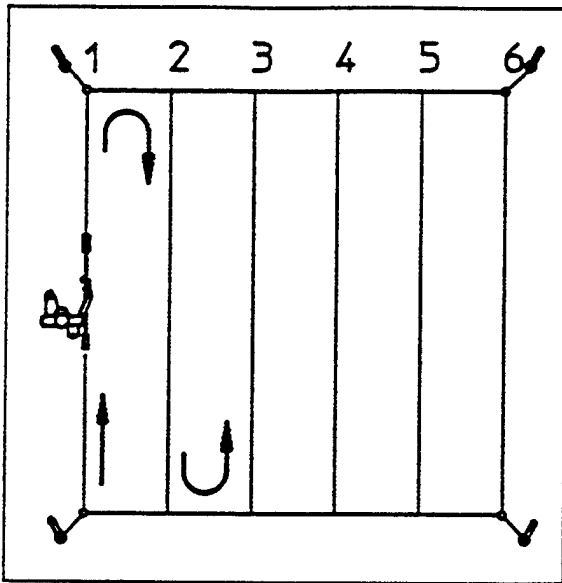


Recently, the value level of Fluxgate Gradiometers produced by Vallon were proven as an effective technology during the UXO Technology Demonstration Program at Jefferson Proving Ground 1994.

An enhanced "Turnkey" UXO detection system has been developed by Vallon based on the experiences and needs of the user community. Both military EOD and OEW companies require a system which is highly portable, versatile in use, easy to operate, and reliable for continuous use in the field.

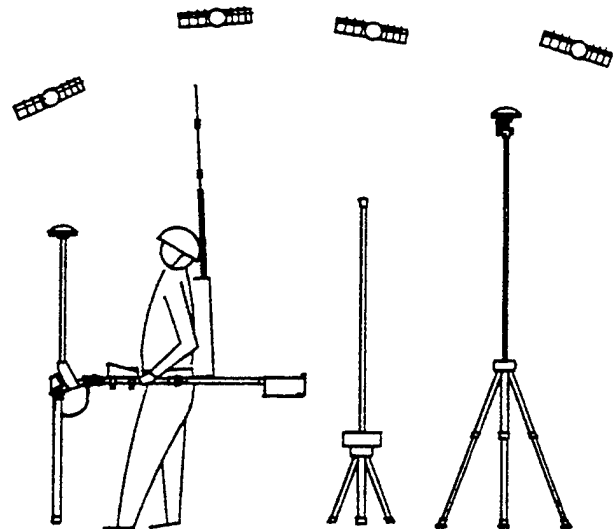
To ensure that these advantages do not get lost when enhanced with "computer-aided detection", it is absolutely necessary to have an exact navigation system for the applied detection sensors. Therefore, Vallon developed two distinct navigation aids for use by the same detection equipment:

A) SEPOS®-Sensor Positioning System (manually operated guiding lines with accuracy markers).



Application:  
Narrow roads, narrow valleys, forested areas, and bore holes.

B) DGPS-Differential Global Positioning Satellite (radio link navigation - no guiding ropes required).



Application:  
In open areas such as firing ranges where clear satellite links are available.

In both cases the magnetometer data is recorded together with the data of the navigation system. A final target list produced after evaluation comprises the combined data with a target description and target location (the GPS coordinates are easily converted to UTM).

The use of "conventional" UXO detection methods has vastly improved with the turnkey system approach increasing detection performance and detection quality assurance. Current improvements with GPS technology has increased detection location accuracy to a very high level. The results of these combined improvements include:

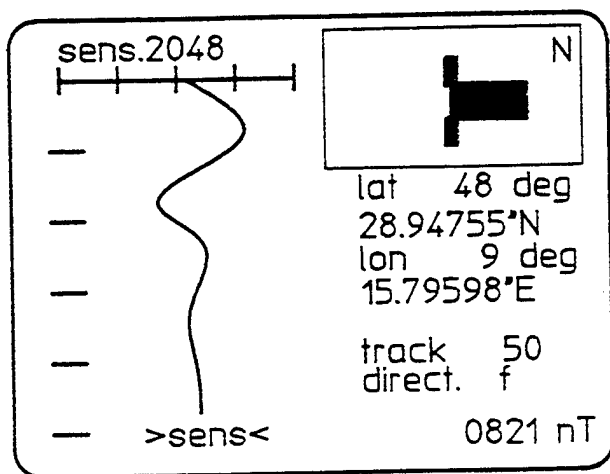
- The EOD personnel operating the system can fully concentrate on the detection survey.
- The target data collected with GPS values are a reliable reference without the need for physical reference points which could become lost from extreme weather conditions, construction changes, etc.
- Quality assurance can be performed at the data analysis level on a PC. It is not necessary to repeat an area survey.

## DATA QUALITY REQUIREMENTS

Two considerations are very important to obtain the desired results of high quality detection data:

1. Reliable data acquisition.
2. No change in the "original" measured data during the evaluation.

The reliability of the data survey for UXO's is ensured by the use of a data acquisition unit with graphically displayed information for the operator. With the use of this real time display, the survey can be "quality checked" in the field during the operation. Should an error occur, the localized area of the survey field can be immediately re-surveyed without effecting the overall collected survey data. Thus, quality and reliable data is ensured throughout the survey operation.



Vallon GmbH produces a complete detection system which includes the Micro Computer MC1 for data acquisition. The MC1 displays actual true-to-scale nT values at the present survey location of the magnetometer. At the same time, the last segment recorded survey tracks (5.4 meters), are also on display.

When the GPS option of the MC1 is in operation, the operator now has directional guidelines on the display. This accuracy points the way for each surveyed track to be recorded. MC1 programming ensures that all GPS tracks are in order for correct field coverage and tracks cannot be repeated or left out. This means that the collected values, which are later transferred to a PC for analysis, are absolutely complete and free of errors.

The nT values of buried ferrous objects can be very different depending on the size, magnetic characteristics,

position (angle), and influences of other nearby ferrous objects. Therefore, it is necessary that the nT values are recorded genuine and with absolute accuracy. On the MC1 display, an operator will recognize the characteristic features of a ferrous object (UXO).

**THE ORIGINAL DATA SHOULD NOT BE CHANGED BY ANY CALCULATION OR MANIPULATION.**

Vallon GmbH also produces the signal processing software EVA (Evaluation and Analysis), as an optimum tool for this purpose. "Original data" collected from the MC1 may be displayed on the EVA program in parallel to an "ideal graph" with true scale representation. With this means, the software operator can evaluate the quality of the data and manually influence complicated signal graphs to avoid any misinterpretation by the computer.

On the completion of a data analysis, a final report is produced which includes a target (UXO) list and a true-to-scale target map. Important information is provided on the target list including target location (latitude and longitude when GPS is used), target depth, signal size of target, inclination, etc. The target map provides an excellent visual representation on the levels and locations of contamination.

## CONCLUSION

In brief, it is now possible to obtain high quality and reliable data from a UXO field survey operation. Having stored and analyzed target data provides baseline information for the present and future survey of a given site. An integrated "turnkey" system is now field usable and can provide a higher level of quality assurance over past manual operation methods.



# Rapid Response: A Demonstration of Rapid Environmental Assessment Technologies for Mine Warfare

William Roderick  
SACLANT Undersea Research Centre  
400 San Bartolomeo  
La Spezia, Italy

**Abstract-Rapid Response** is a series of Military Oceanography (MILOC) surveys that demonstrates undersea warfare Rapid Environmental Assessment (REA) technologies in a tactically useful time frame. Examples are given here of mine hunting and seabed classification technologies that were used in Rapid Response '96 in the central Mediterranean.

## I. INTRODUCTION

Rapid Response 96 was conducted during the August to September time frame in the central Mediterranean. The aim was to demonstrate NATO's capability to provide environmental data relating to ASW, MCM, and AW to military planners and operators in a tactically usable timescale. The environmental measurements were performed prior to a NATO exercise (Dynamic Mix) and the data were provided at a pre-exercise brief to support the tactical commanders. The environmental characteristics of the operational areas in the central Mediterranean are well known to the SACLANT Undersea Research Centre, who had responsibility for the Military Oceanography (MILOC) survey. This area was chosen for the initial Rapid Response site because of the abundance of oceanographic and geoacoustic data that were available. This archival information was then supplemented by in situ measurements of all aspects of undersea environmental data including nowcasting and forecasting of the oceanographic conditions; acoustic measurements of propagation, ambient noise, and reverberation; and geoacoustic data relating to seabed properties for mine hunting, probability of mine burial, and environmental data to support amphibious landings. The data were obtained from several NATO platforms involved in the Rapid Response exercise.

## II. BACKGROUND

The concept of Rapid Environmental Assessment (REA) supports CJTF and rapid reaction forces in the preliminary stages of a crisis. The objective demonstrates the type of environmental support that could be made available in an international crisis area. REA of an unknown littoral area is important in all aspects of undersea warfare- from deployment and operational planning to on-scene tactical execution. Platform dependent methods and techniques that can be utilized to support prediction of the undersea environment in a conflict are shown in Fig. 1. As an example, if NATO forces have air superiority and sea control then the limited data available obtained through archival and covert methods can be expanded and enhanced through the use of air-deployed sensors and sensors aboard

survey and warships. Depending on the quantity and type of data being transferred, the communication of the data from the platforms to a command centre may require high data rate links. The environmental data are incorporated into systems that provide operational planning guidance and performance prediction of ASW and MCM sonars.

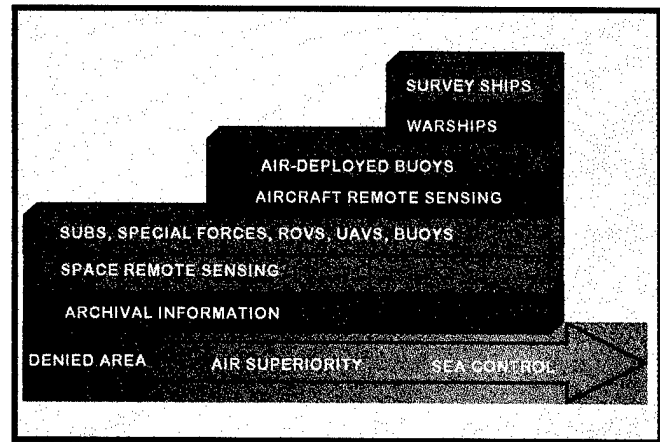


Fig. 1 Rapid Environmental Assessment methods of an unknown littoral area Vs military capabilities

## III. RAPID RESPONSE 96

Rapid Response is an initiative of the SACLANT Military Oceanography (MILOC) survey series and is being conducted by COMNAVSOUTH on behalf of CINCSOUTH [1]. The survey was artificially linked to a Central Mediterranean NATO exercise (Dynamic Mix 96) to demonstrate the type of environmental data that could be made available in a crisis situation. Participating in the measurement phases were NATO's research vessels NRV ALLIANCE (and the T/B MANNING), USA's USNS PATHFINDER, UK's HMS HERALD, and Italy's ITS MAGNAGHI. Marine Patrol Aircraft from Canada (CP-140), The Netherlands (P3-C), United Kingdom (NIMROD), and the US P3-C participated in deploying expendable sensors. The US Sixth Fleet flagship USS LASALLE performed the functions of command and control and operational data fusion centre. The SACLANT Undersea Research Centre (SACLANTCEN) coordinated the oceanographic and acoustic data collection for Rapid Response 96. The environmental data collected aboard all the platforms were communicated to the SACLANTCEN. Data were integrated into ASW, MCM, and AW briefing guides provided to the various commands that were

preparing for the NATO exercises Dynamic Mix 96 (and DAMSEL FAIR 96).

Communication of the data from the platforms involved the use of the INTERNET, cellular telephones, military messages, courier, and secure phone (see Fig. 2).

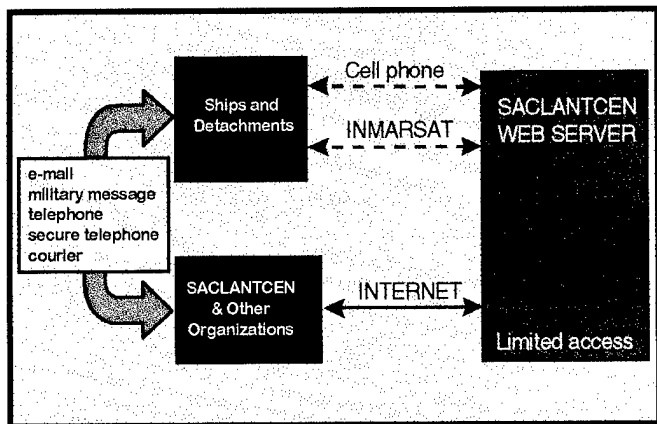


Fig 2 Transfer of environmental data from the ships and detachments involved SACLANTCEN web server with access limited to participants

A limited access homepage was installed on the Centre's web server. Ships transferred (or received) environmental data using PCs and modems. Aboard the platforms cellular phones transmitted the data to the Centre. The successful use of the cellular phones was dependent on the range of the ships from the telecommunication relay centres; given the location of the exercise, this was not a problem. However, if the exercise had been further from the mainland, alternative communication schemes would have been necessary.

Rapid Response 96 environmental data that impacted ASW, MW, and AW operations were transmitted to SACLANTCEN. The data were assembled into environmental briefing guides and presented to the commands and command ships several days prior to Dynamic Mix. In addition to the briefing guides, STOICs (Special Tactical Oceanographic Information Charts) were produced by the US Naval Oceanographic Office, which incorporated both archival data and data obtained during Rapid Response.

#### IV. MINE WARFARE ENVIRONMENTAL TECHNOLOGIES

##### A. EXPENDABLE BOTTOM PENETROMETER

In addition to detailed bathymetric charts, a rapid assessment of seafloor properties was provided by the use of expendable penetrometers. Free-falling penetrometers, developed on the basis of existing XBT technologies, were deployed in a grid to measure the geoacoustic and geotechnical properties of the seabed. The techniques were developed by the SACLANTCEN and Lamont-Doherty Earth Observatory of Columbia University [1]. The penetrometers (probes) are modified XBTs that have their

thermistors replaced by accelerometers. The penetrometers have been calibrated previously in field experiments. Measurements have been conducted in New York Harbour, the Mediterranean, and in Eckernforde Bay. It is possible to make a first-order classification of sediment type, shear strength and geoacoustic properties from the deceleration signal produced from the initial plastic penetration and damped oscillation. The information gained from the probes can be utilized in various applications-from acoustic propagation to mine burial.

In Rapid Response the probes, Expendable Bottom Penetrometers (XBP), were deployed from the NRV ALLIANCE in a mile by mile spacing in the MW and AW areas. The areas were then classified as to sediment type and parameters related to mine burial. The data were divided into three types: Type 1 (red) represented granular sediments that had high decelerations; Type 2 (green) had transitional materials that represented mixtures of sands and clays; whereas Type 3 (blue) had minimal decelerations on impact and represented soft fine-grained bottoms such as clay and silt. An example of this bottom classification is given in Fig. 3 for an undefined location. The XBPs are a valuable tool for rapid environmental assessment of areas with unknown geoacoustic properties and can provide information related to mine hunting and potential for mine burial.

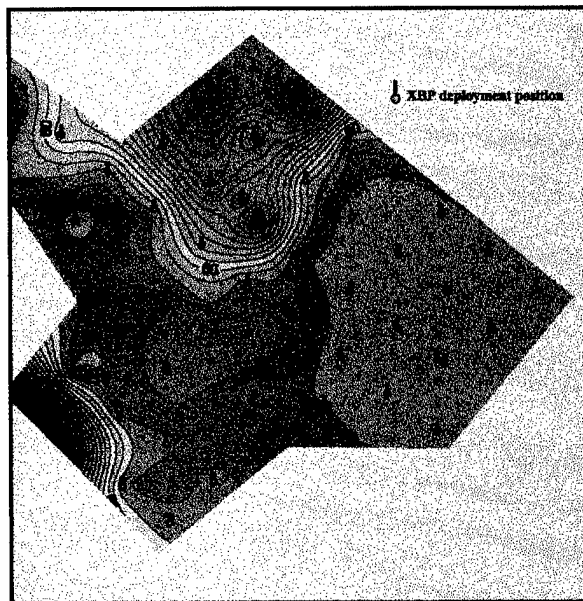


Fig. 3 Sediment classification based on results from XBPs

##### B. HIGH FREQUENCY BOTTOM REVERBERATION

Data were collected from a high frequency acoustic system deployed from the NRV Alliance. The system was tethered from the ship and bottom reverberation was measured at approximately fifteen sites to determine the bottom scattering strength as a function of grazing angle. The

scattering strength gives an estimate of the average reverberation level that can be expected for an area. Also estimated was the probability distribution function of the scattering cross sections to give an estimate of the clutter—a measure of the number of reverberation returns that exceed the average value. The clutter expresses the nonuniformity of the area and provides clues as to the degree of difficulty in detecting and classifying mines with mine hunting sonars. Data that represent three different types of scattering regimes are shown in Fig 4. The expected value of the reverberation levels can be estimated from the scattering strength values. It can be seen that the data represented by the red color has the highest reverberation levels and that represented by blue has the lowest reverberation levels. This data was supplemented by core samples and videos taken of the seafloor. The high reverberation levels shown above are associated with numerous shellfish covering the seafloor and the low reverberation is attributed to a featureless seafloor. Also, a correlation can be seen in this data between the high levels of bottom backscatter and the degree of clutter seen in the area.

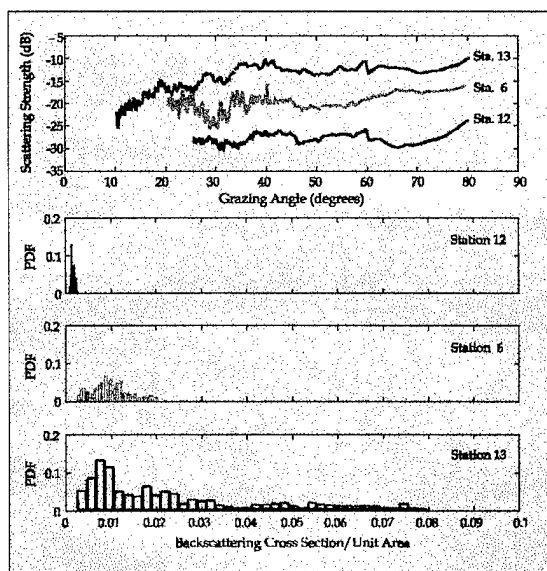


Fig. 4 Bottom backscattering strength as a function of grazing angle

### C. SEABED CLASSIFICATION

A towed parametric sonar (TOPAS) was deployed from the T/B MANNING. The array generated a narrow beam of broadband acoustic energy at normal incidence to the bottom. The acoustic signals were reflected from the bottom, sub-bottom features and multiple reflections were received from the bottom and sea surface interfaces. Referring to Fig. 5, the top of the figure shows several TOPAS returns from the seabed in a region of sand with patches of posidonia (a type of seagrass found in the Mediterranean). The sand return risetime is sharp and its time dispersion contains information on seabed roughness and geoacoustic property variations within the seabed. The effect of posidonia is to obscure the seabed and reduce the

energy in the multiple reflections. This masking effect is shown in the lower right portion of the figure. A track plot is shown, colored according to acoustic seabed classification.

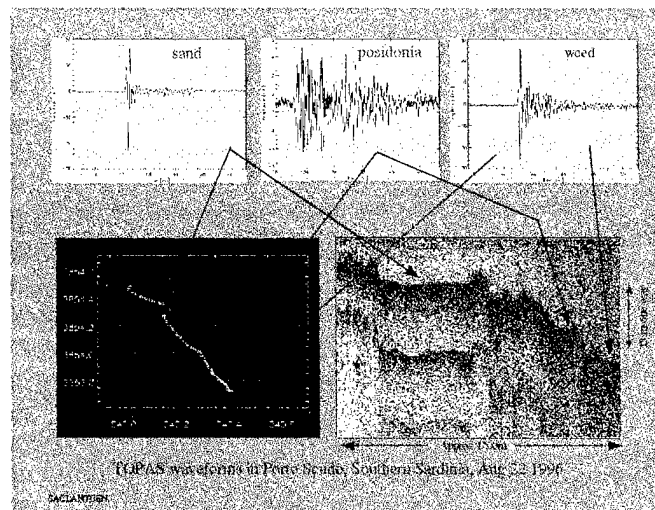


Fig. 5 Bottom characterization with a broadband parametric array

Analysis of the time dispersion of the reflection from the sea bottom and sub-bottom features provides information as to the difficulties of conducting mine hunting operations in a spatially variable shallow water environment [2].

### V. CONCLUSIONS

Rapid Response 96 was the first demonstration that rapid environmental assessment technologies could be provided to operators in a tactically useful timeframe. Lessons learned from this MILOC exercise will impact the next survey to improve and expand the communication and REA capabilities. The REA technologies shown here are examples from the mine hunting viewpoint and do not include the water column (temperature, salinity, sound velocity) measurements that are associated with all aspects of undersea warfare.

### REFERENCES

1. T. Akal and R. Stoll, "An expendable penetrometer for rapid assessment of sea floor parameters," UDT 96 pp. 117-124, 2-4 July 1996
2. O. Bergem, E. Pouliquen, A. Lyons, N. Pace, "Normal incidence seafloor classification using a parametric array," Oceans 96 pp. 1052-1057, 1996



# SLICE - A STABLE RECONFIGURABLE PLATFORM A NEW MCM OPPORTUNITY

STEVEN LOUI  
TERRY SCHMIDT

PACIFIC MARINE & SUPPLY  
LOCKHEED MARTIN

STEVEN LOUI

As president of Pacific Marine, Mr. Loui has developed and operates two SWATH Ships; the 372 lt NAVATEK I and the 94 lt NAVATEK II. In March of 1997, Mr. Loui will add a third small waterplane area ship to his fleet - the SLICE ATD vessel.

TERRY SCHMIDT

Mr. Schmidt has been involved in high performance advanced ship development including the Stealth Ship Sea Shadow for over 20 years. Currently Mr. Schmidt is Lockheed Martin's Program Manager for the ONR's Advanced Technology Demonstration of his patented high speed SLICE technology.

## INTRODUCTION

The suitability of SWATH as a mine countermeasures platform was confirmed in studies reported by the Naval Studies Board in 1981/82 and again in 1993 (MINE COUNTERMEASURES TECHNOLOGY, VOLUME IV, THE SWATH AS AN MCM PLATFORM). Lockheed Martin and Pacific Marine have developed, under an Advanced Technology Demonstration (ATD) cooperative agreement with the Office of Naval Research, an advanced high speed SWATH hullform called SLICE, Figure 1 . Arrangement, operations and performance of the SLICE vessel provide a substantial improvement over the traditional SWATH hullforms for the MCM missions. Results of a conceptual design study using SLICE technology for an air transportable Mine Search Unit (MSU) Craft are presented.

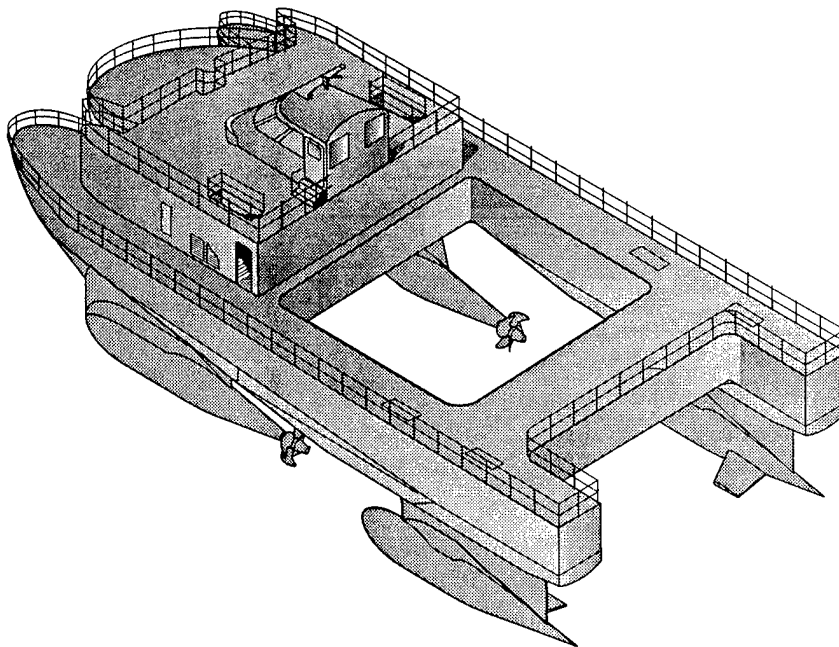


Figure 1 SLICE ATD VESSEL



This Page Intentionally Left Blank

## SLICE TECHNOLOGY

Displacement ships have been limited in speed by the wetted friction and wavemaking resistance created by their hull forms. Viscous resistance is determined by a hull's wetted area and speed. Wavemaking resistance is however related to the hulls speed to length ratio commonly referred to as Froude Number ( $F = V\sqrt{gL}$ ). A large increase in the wavemaking resistance occurs at Froude numbers between 0.4 and 0.8. At a hulls worst speed to length ratio ( $F \approx 0.5$ ) the wavemaking resistance of a hull is often larger than the viscous resistance. This speed, known as the hump speed, is seldom exceeded. Traditionally a vessel is designed to operate below the hump speed. If more speed is required the designer increases the vessel's length. Maximum ship speed vs. length is shown in Figure 2. As an example; if a ships mission requires a 20 knot speed then the ship must be at least 200 feet in length to operate efficiently and if the mission requires a 30 knot speed then a length of over 500 feet would be necessary for efficient operation. The relation between viscous and wavemaking resistance is shown in Figure 3. It is apparent that for current displacement hullform designs the limiting Froude Number for efficient operation is 0.4.

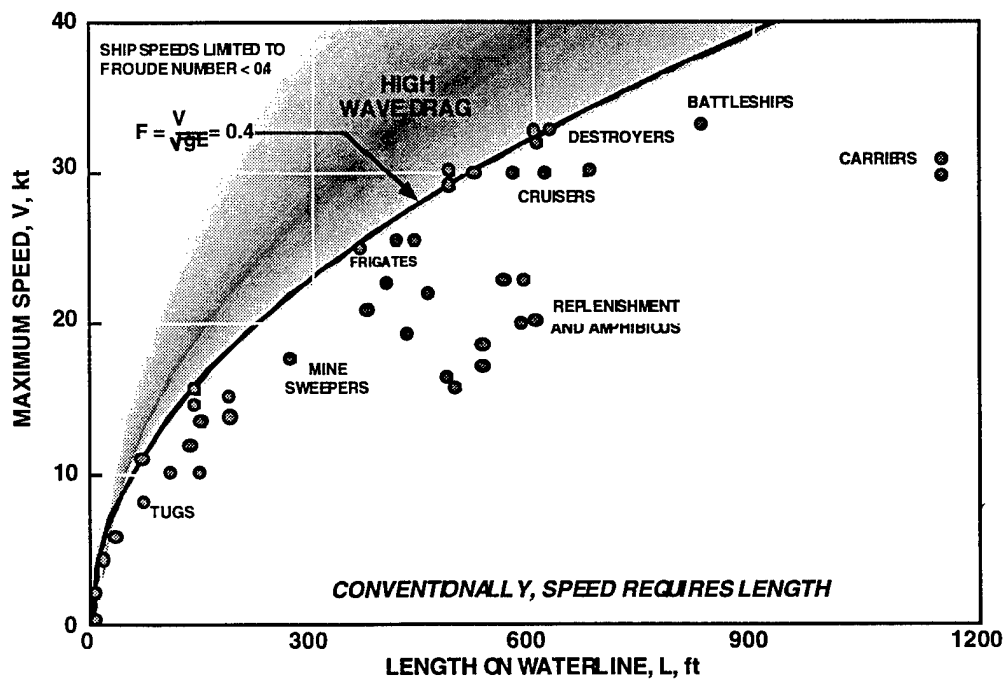


Figure 2 DISPLACEMENT HULL MAXIMUM SPEED VERSES LENGTH

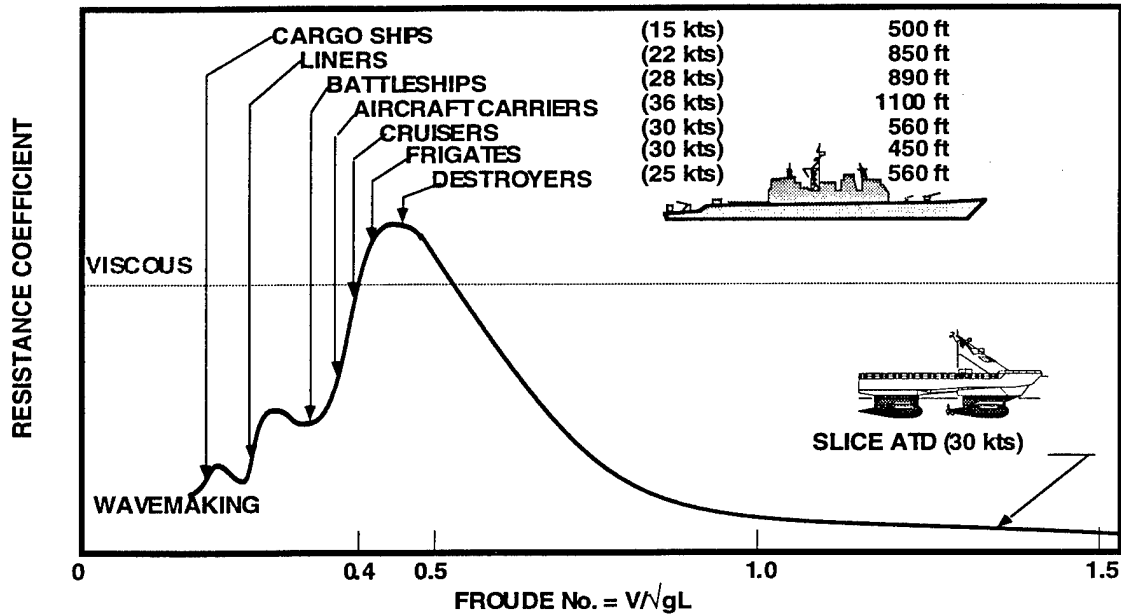


Figure 3 COMPARISON OF WAVEMAKING AND VISCIOUS RESISTANCE

A new approach to reducing the resistance and allowing smaller vessels to operate at high speed has been developed at Lockheed Martin. The fundamental principal is to configure the displacement portion of the hull into short lengths (by traditional standards) thus allowing the hull to operate at high Froude numbers, past the hump, where the wavemaking resistance is low as shown in Figure 3. Due to the short hull lengths the wavemaking hump ( $F \approx 0.5$ ) occurs at a low speed where sufficient power is available for transition through the high resistance hump region. This high Froude Number technology is being demonstrated by the SLICE ATD vessel shown in Figures 1 and 4

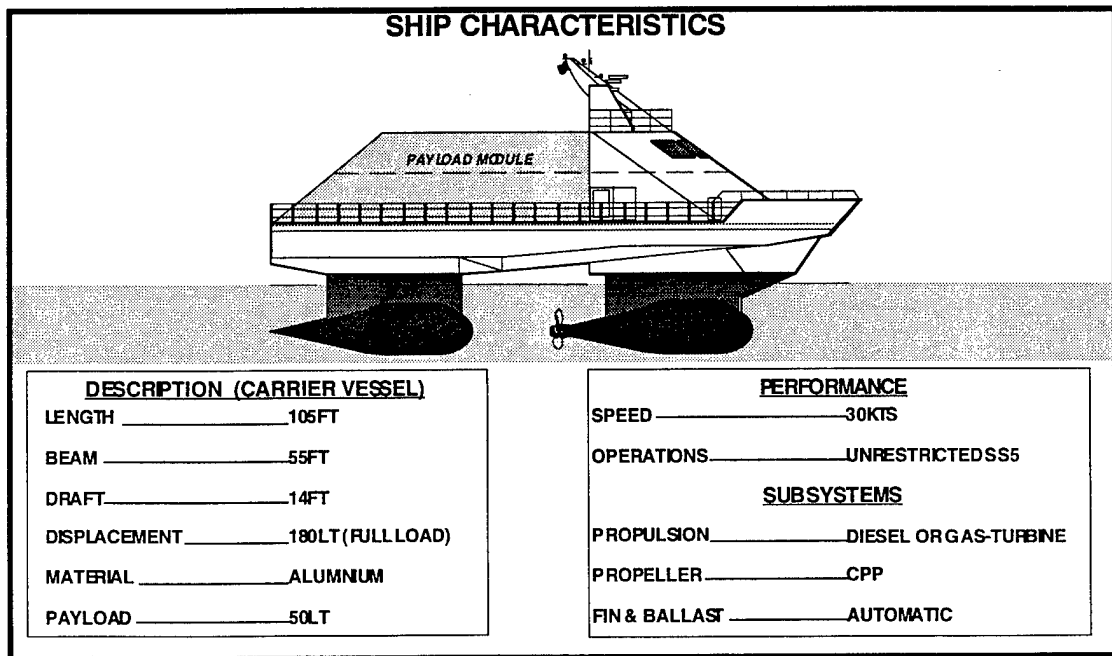


Figure 4 SLICE ATD Vessel

## SPECIFICATION SUMMARY

The MSU Vessel Concept design presented herein was developed from the Mine Search Squadron's Boat Specification for the U. S. Navy Mine Search Units. The following is a summary of that specification.

MSU CRAFT MISSIONS	<p>ACOUSTIC SEARCH &amp; REMOTE VISUAL ID DETECT AND IDENTIFY FOR:</p> <ul style="list-style-type: none"><li>- AVOIDANCE</li><li>- NEUTRALIZATION</li><li>- REMOVAL</li></ul> <p>RAPIDLY DEPLOYABLE</p> <ul style="list-style-type: none"><li>- AIR - C5 AIRCRAFT TRANSPORT</li><li>- LAND - CONVENTIONAL TRAILER</li><li>- 72 HRS - ASSEMBLE/DISASSEMBLE</li></ul> <p>6 CREW + 2 OPERATORS 12 HRS CONTINUOUS OPERATIONS HEAD, FRESH WATER, FOOD STORAGE/PREP.</p> <p>AUTOMATED BALLASTING OF TRIM &amp; DRAFT CONDUCT OPERATIONS AT 0 SPEED, 4-6 Kts, 18Kts CRUISE 15 Kts, 500 NM</p>
PERFORMANCE	<p>SEAKEEPING</p> <ul style="list-style-type: none"><li>- HIGHLY STABLE PLATFORM 3-5 KNOTS</li><li>- MOTION SICKNESS INDEX (MSI)</li><li>- MOTION INDUCED INTERRUPTIONS (MII)</li><li>- SEA STATE 4- SPEEDS 3 TO 18 KNOTS</li></ul> <p>SPEED</p> <ul style="list-style-type: none"><li>- 18 Kts MINIMUM FOR TRANSIT</li><li>- 4-6 Kts SONAR TOW</li><li>- 0 Kts ROV OPS.</li></ul> <p>MANEUVERING</p> <ul style="list-style-type: none"><li>- ZERO SPEED TURNING</li><li>- 20 Kts WIND &amp; 3 Kts CURRENT</li></ul>
ARRANGEMENT	<p>FOR TRANSPORT</p> <ul style="list-style-type: none"><li>- HEIGHT MAX 160 INCHES</li><li>- WIDTH MAX 216 INCHES</li><li>- PER MIL STD 1791</li></ul> <p>DECKHOUSE</p> <ul style="list-style-type: none"><li>- CABIN HEIGHT 6 FT. 3 IN. MIN.</li><li>- AREA PER PAYLOAD</li></ul> <p>PORTABLE DAVITS (2) WITH WINCHES</p> <ul style="list-style-type: none"><li>- BOW</li><li>- FANTAIL</li><li>- 1000 LBS CAPACITY</li></ul> <p>PAYLOAD 3.9 LT</p> <p>TWIN SCREW</p>
CONSTRUCTION	<p>SWATH COMMERCIAL PRACTICES CERTIFIED-USCG, ABS, LLOYDS OR OTHER ALUMINUM OR GRP - CORROSION PROTECTION WATERTIGHT COMPARTMENTATION DIESEL PROPULSION AND POWER GENERATION KEELS - GROUNDING, TRAILER, PIER MINIMIZE MAGNETIC MATERIAL ACOUSTIC DAMPENING - MACHINERY</p>

## MSU CRAFT CONCEPT SUMMARY

The MSU Craft Design Concept is based on 20 years of SWATH research, development, and construction at both Pacific Marine (Navatek) and Lockheed Martin. The SLICE Advanced Technology Demonstration vessel currently being constructed under a Cooperative Agreement between the Office of Naval Research (ONR), Lockheed Martin and Pacific Marine is the basis for the MSU Craft Design. The SLICE configuration was selected as the result of numerous trade studies where it showed a significant advantage over conventional SWATH designs in the following areas:

### Vessel Arrangement

Typically the conventional SWATH has Longitudinal Center of Buoyancy and Center of Gravity (LCB/LCG) problems. This results from the need to locate the propulsion system and payload aft where with the conventional SWATH hull/rudder arrangement buoyancy is a minimum.

The forward location of the SLICE Propulsion System allows for a balanced design distributing the weight longitudinally consistent with the distribution of buoyancy. Ship systems forward and payload aft.

### Vessel Operations

The MSU Mission requires significant handling operations (deployment/towing/recovery/boarding) much of which is conducted from the stern of the vessel. Even with its "Texas Tower" and propeller guard/shroud the TAGOS-19 has a history of towed array propeller entanglement and damage.

The forward propulsion of the SLICE arrangement is ideal. With its propeller amidship it is protected from virtually all hazards including docking, grounding, handling operations, vessel launching, ground and air transportation.

### Vessel Performance

Low waterplane area SWATH vessels of all types (single/twin strut etc.) have demonstrated excellent seakeeping performance. Speed however has always been an issue.

The SLICE ATD vessel was developed to operate efficiently at 30 kts. When scaled to the MSU Craft size this speed equates to 18 kts, the design requirement. Unlike the SWATH which is operating inefficiently near its wave drag peak at the 18 kt speed SLICE is operating at peak efficiency well above the wave drag hump. At towing speeds from 0 to 6 kts the SLICE configuration is operation below the wave drag hump at an efficiency equal to SWATH.

## **MSU CRAFT FEATURES**

The 25 Long ton 52 foot vessel was determined through sizing studies to be the minimum size necessary for seastate 4 operations and payload requirements.

### **GENERAL CHARACTERISTICS**

HULLFORM	SLICE High Speed SWATH Variant
DISPLACEMENT	25 LT
LENGTH OVERALL	52 feet
BEAM	
Operational	26 feet 9 in.
Transport	12 feet
HEIGHT	
Operational	17 feet 9 in. ( baseline to top of deckhouse)
Transport	12 feet 8 in.
DRAFT	6 feet

### **PERFORMANCE**

SPEED	18 kts
SEAKEEPING	Fully Operational Through SS 4 Preferred Headings SS 5 Survivable SS 6
MANEUVERING	Stabilizer Steering as used on Sea Shadow, TAGOS-19 and TAGOS-23 SWATHS (Lockheed Martin Patent) Differential propulsion hydraulic drive motors

### **ARRANGEMENT**

DECKHOUSE	10 ft. x 22 ft.
DECKAREA	1100 sq. ft. approx.
HOISTING	Hoisting Structural Attachments (4) at Deck Hinges
PAYLOAD	3.9 lt (includes crew)
BREAKDOWN	No disconnect of subsystems, electrical, propulsion is required Hinged deck bolted joint Breakdown rigging self contained
JACKING	Onboard hydraulic jacks to support breakdown for transport

### **PROPULSION**

APPROACH	Forward location ideal for payload weight distribution balance Forward propeller: minimizes tow cable interference maximum protection during tow, deployment/recovery maximizes propeller protection - tow, docking, transport
PRIME MOVERS	Two 300 hp Cummins Diesels 6CTA8.3M1
TRANSMISSION	Rexroth AA4v250 Hydraulic Pumps
MOTOR	Rexroth AA2FM500
GEARS	3.1:1 Reduction
PROPELLERS	Fixed Pitch 3 ft. 6 in. diameter

### **CONTROL**

CONFIGURATION	TASC Control System, Proven Marine Applications, Navatek II & SLICE
HARDWARE	Reconfigurable, Adaptive (self defining, self tuning, graceful degradation)
SOFTWARE	PC Based COTS System Motion Control - Integrated fin (high speed) and ballast (low speed/trim) Subsystem Control, Monitor and Alarm Steering, Propulsion, GPS Sensor Based-Way Point Navigation

# MSU CRAFT PERFORMANCE

## RESISTANCE AND PROPULSION

Resistance and powering predictions shown in figure 5 are based upon the results of a 1/4 scale model tests conducted at the NSWC, Carderock Md. towing basin. The 18 Kt maximum speed of the MSU vessel can be achieved in calm water with 415 BHP.

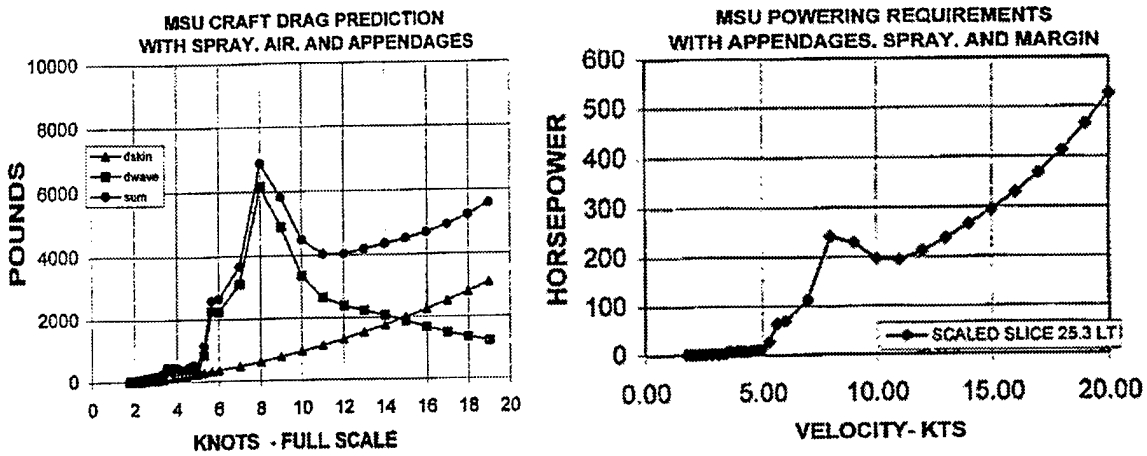


Figure 5 MSU Resistance and Powering

## SEAKEEPING

Motions data shown in Figures 6 through 8 were obtained in a 1/4 scale model seakeeping and loads test conducted at the NSWC, Carderock Md. towing basin. Results presented are for zero speed.

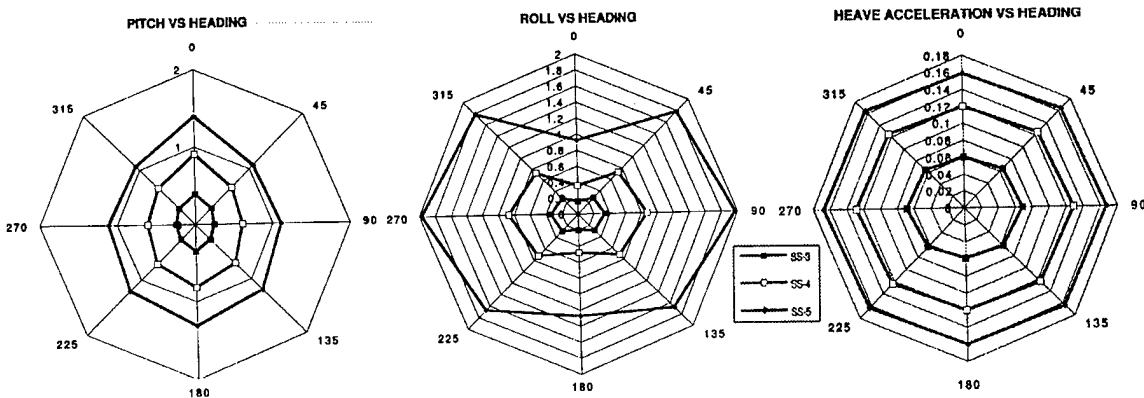
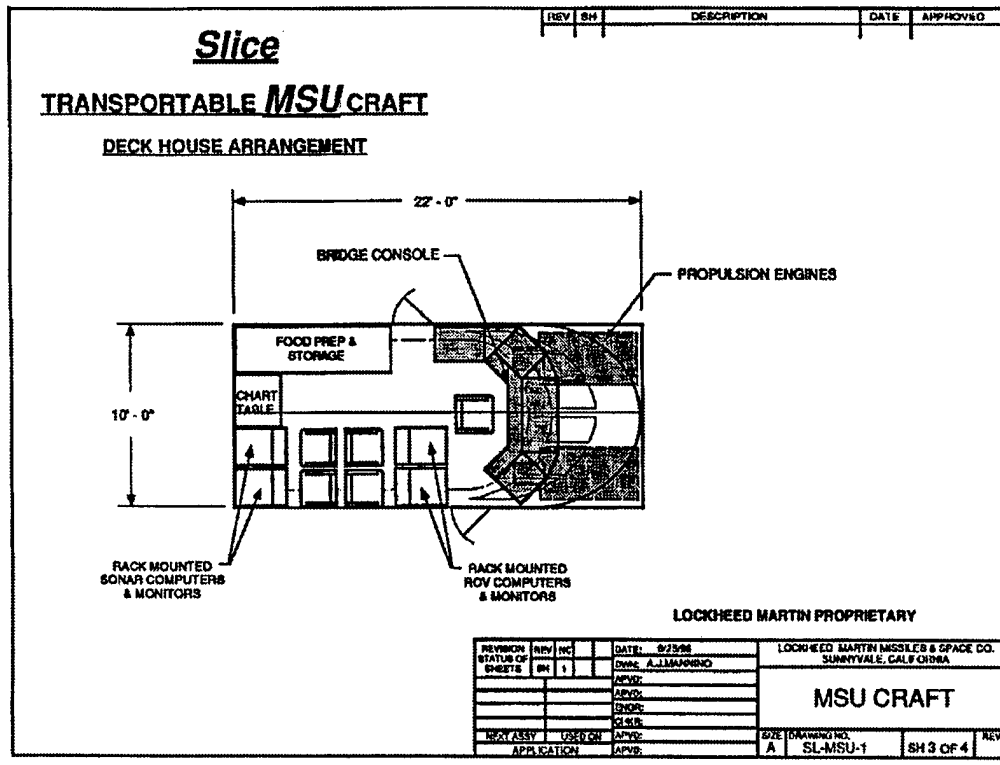
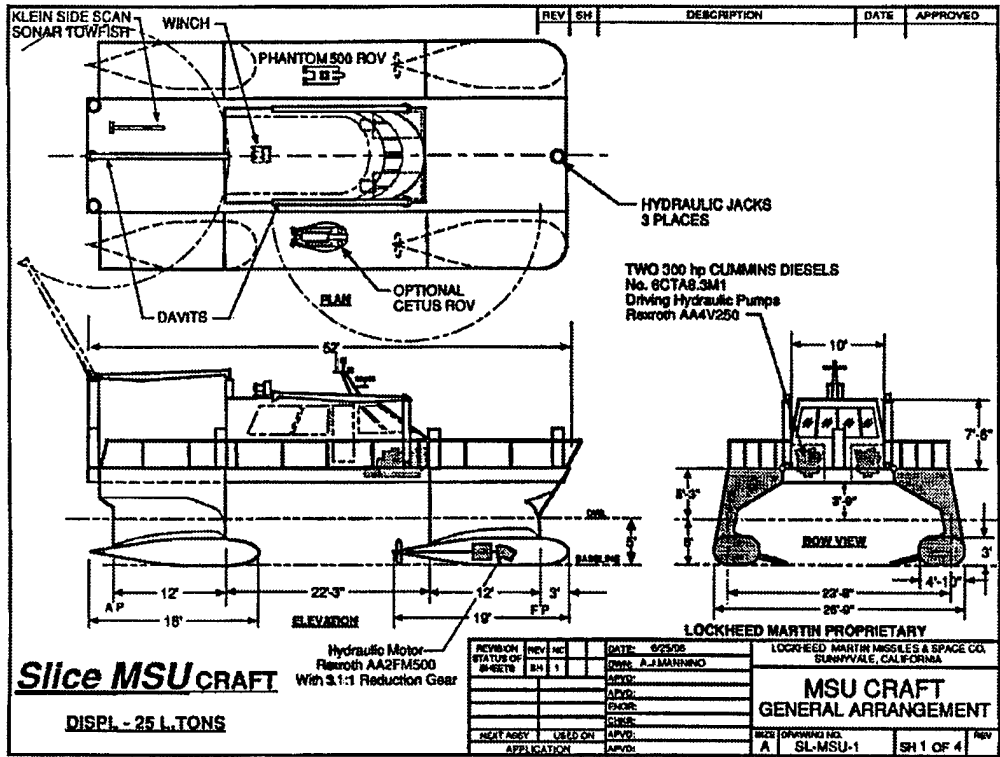


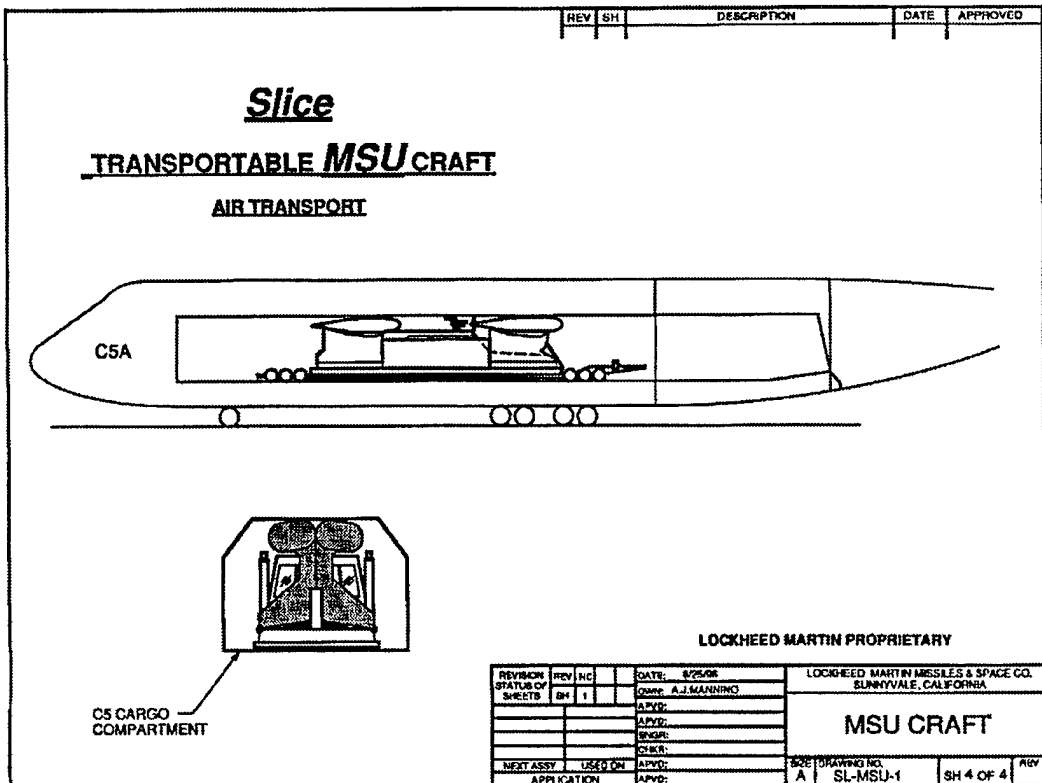
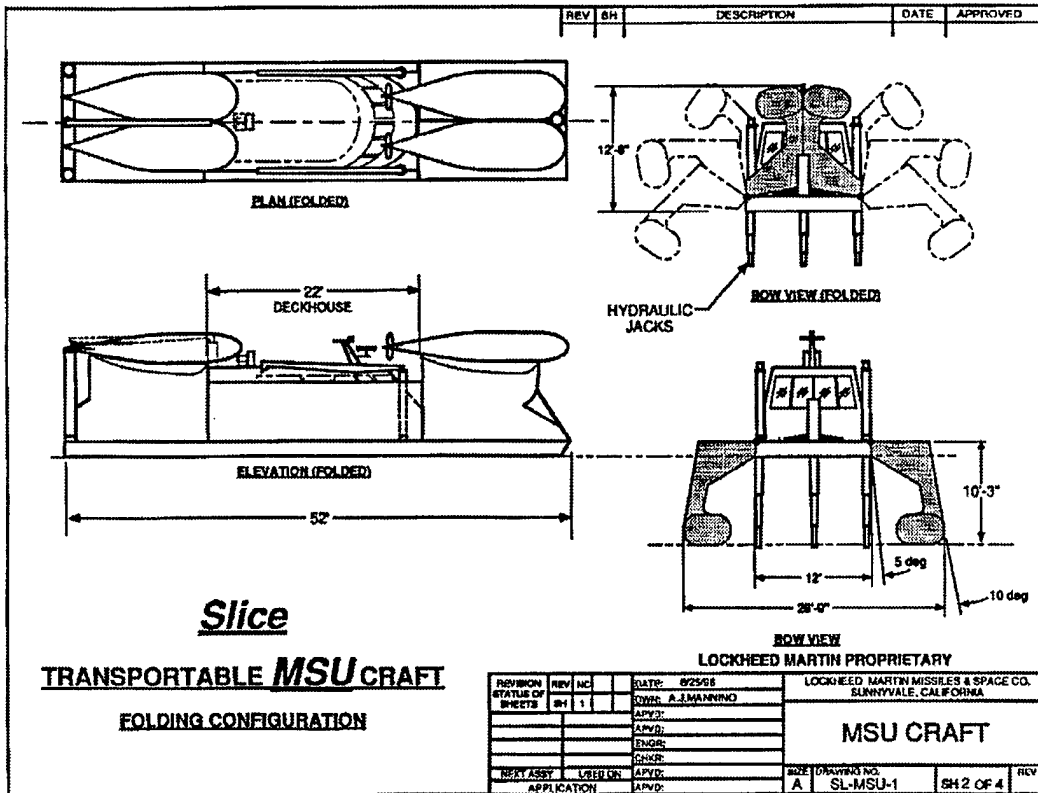
Figure 6 MSU Zero Speed Motions

# MSU CRAFT DESCRIPTION

The following drawings Present the MSU Craft concept General Arrangement, Erection/Transportation and Estimated Weights. Transportation and deployment of the vessel can be conducted without disconnecting electrical, hydraulic or mechanical systems.







MSU ESTIMATED WEIGHTS STATEMENT

<u>WBS</u>	<u>DESCRIPTION</u>	<u>WEIGHT (L. TONS)</u>
100	STRUCTURE	11.50
200	PROPULSION	2.10
300	ELECTRICAL POWER	1.00
400	COMMAND & CONTROL	0.40
500	AUXILIARY SYSTEMS	1.40
<u>600</u>	<u>OUTFIT &amp; FURNISHINGS</u>	<u>0.45</u>
	LIGHTSHIP SUBTOTAL	16.85
	<u>MARGIN (10%)</u>	<u>1.69</u>
	LIGHTSHIP WITH MARGIN	18.54
F40	FUEL	2.30
F50	WATER & PROVISIONS	0.23
<u>F60</u>	<u>OPERATIONAL PAYLOAD</u>	<u>3.93</u>
	FULL LOAD CONDITION	25.00

CONCLUSIONS

Application of SLICE technology to the MCM MSU craft has several advantages over the conventional SWATH hullform. The low resistance, high speed hullform allows a fuel efficient high speed transit at reduced power for small vessels. With the primary machinery spaces located forward, a well balanced weight arrangement exists providing for a significant aft payload capability for MCM mission equipment. Location of the propellers amidship minimizes the potential for grounding or entanglement during mission operations. An MSU craft system using a low waterplane area SLICE hullform will provide a highly effective MCM mission capability.



# Rapid Response Minesweeping

by Carl Fisher, EDO Corporation

EDO Corporation, designer and developer of the MK 105 Airborne Magnetic Influence Minesweep System, is embarking on a new generation of mine countermeasures systems. These systems incorporate available technologies for rapid introduction and application to a myriad of potential host platforms. The application of this technology has made low-cost, modular, minesweeping systems available throughout the world—a world facing a significant naval mine threat.

## THE GLOBAL MINE THREAT

Mines are a cheap force multiplier that give any nation in the world the ability to stop commercial or military shipping by any other sea-going nation. The destructive force of these mines has been effectively demonstrated numerous times over the past 50 years. There are 20 nations that have the capability to manufacture mines, many more that have the capability to buy and deploy these mines, and approximately 1 million mines in the world's inventory. Of the 18 U.S. Navy ships that suffered some sort of battle damage over this 50-year period, 78% of them were as a result of mines. The mine threat has successfully halted the execution of amphibious assault operations and has severely impacted the free transit of commercial shipping. Interruption of trade has resulted in a significant impact on the economies of affected nations. Mines have the capability of neutralizing military superiority as well as creating economic havoc. It is critical, therefore, that nations develop or maintain the ability to respond quickly to this threat in order to minimize the impact of their deployment.

## THE THREAT RESPONSE

The keys to successfully countering this mine threat are speed and effectiveness of response. Not only must a nation be able to respond quickly, but the response must also be of sufficient strength to clear the threat effectively. The response must be able to meet this threat at any place of national interest and should be cost-effective considering the nature and frequency of the threat.

Utilization of current mine countermeasure technology provides a low-risk response for all nations and all operational environments. This incorporates both open-loop sweep technology for maximum system effectiveness and a dipole magnet approach for maximum flexibility of deployment. These technologies do not represent the results of investment in research and development for

new technological approaches, but instead reflect a new application of existing technologies. While it is not new, this technology represents a capability for a quick and effective response to this global threat. The systems that represent this approach are the Modular Open-Loop Sweep system and the Shallow Water Influence Minesweep system.

## RAPID RESPONSE MINESWEEPING CONCEPT

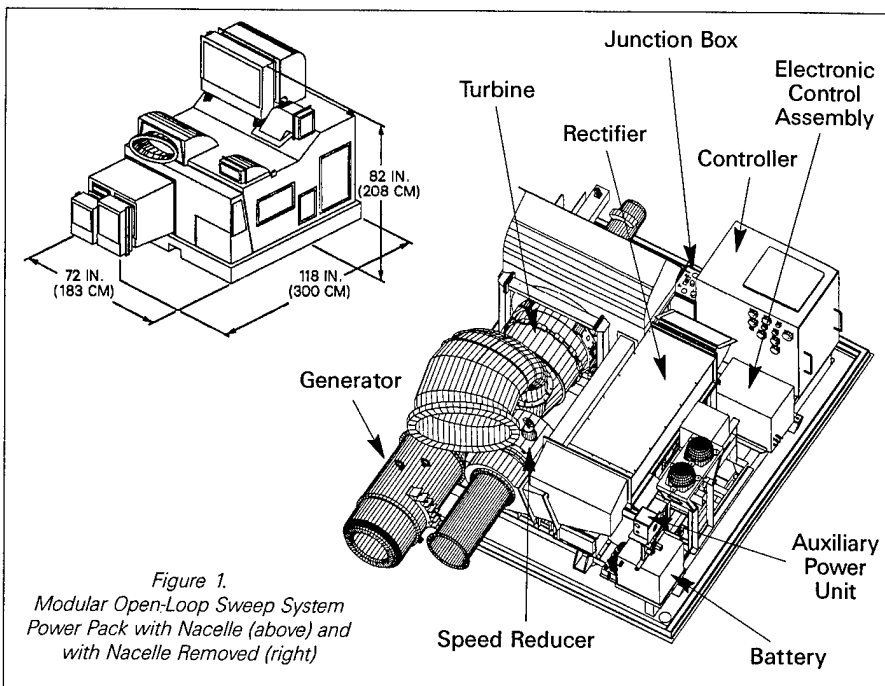
The concept of Rapid Response Minesweeping is based on the principle of modularity and flexibility. Having the capability to quickly and effectively negate a mine threat allows for a national self-sufficiency. Pre-disposition of the rapid response minesweeping components or packaging for quick transit from a central storage location, and designing them for use on surface ship or helicopter platforms, maximizes the response capability and reduces the required response time. This response time is one of the critical elements of this concept. Both the Modular Open-Loop Sweep, designed primarily for surface ships, and the Shallow Water Influence Minesweep System, designed for use on small surface ships and helicopters, meet these critical time requirements.

## MODULAR OPEN-LOOP SWEEP SYSTEM

The Modular Open-Loop Sweep (MOLS)

system is based on a power pack technology that has been proven in service for over 25 years and is currently in production for the U.S. Navy on the MK 105 Mod 4 Airborne Magnetic Minesweeping system. The power pack includes a gas turbine generating set using a Pratt & Whitney PT-6 turbine derivative as the primary power source. When coupled with a generator and rectifier, it provides the capability to generate an output current of 3,500 A and an output power of 3.5 KVA. The specifics of the power pack technology as envisioned for this application are shown in figure 1. Since it generates its own output power, no external power sources are used for this application and only an external fuel connection is required. Therefore, a MOLS system can be installed in a modular configuration on almost any platform that can accommodate a 5,000 lb. (2,275 kgm.) payload. The system has the capability to waveshape and pulse its output current. This provides additional minesweeping effectiveness against most threats. The configuration and capability of this system permit operation in deep water and achieve large swept-path performance. The speed range of the system is dictated only by the operational limits of the surface tow platform.

Along with this power pack, a modular winch assembly and sweep cables are provided. The power pack is packaged to meet the shipboard requirements for noise, EMI, magnetic signature and salt water inges-



tion. It is palletized for ease of installation and removal.

One of the features of this system is its adaptability to surface craft other than those dedicated to mine countermeasures. This includes non-magnetic commercial shipping having the deck capacity for this hardware and the capability to stream sweep cables aft of the ship. Since there is no towed body, there is very little tow capability required by the tow platform. This increases the number of potential platforms that can be fitted with this system and further enhances the its modularity. The power pack portion of this system currently in production for the U.S. Navy only requires modifications involving repackaging for surface ship applications and modification of the winch assembly as part of the modular configuration.

### SHALLOW WATER INFLUENCE MINESWEEP SYSTEM

The Shallow Water Influence Minesweep System (SWIMS), shown in figure 2, was

power source. It can be towed at speeds in excess of 30 knots and can operate in water depths less than 20 feet. The body contains a soft magnetic core wrapped with a coil that is continuously charged to maintain high magnetic levels at all times during the minesweep operation. The electronics required to support this system include five control boxes. With the addition of a laptop computer, the SWIMS can provide a ship emulation capability. This allows the system to conduct all types of minesweeping operations, be it sweeping generically against a specific threat or sweeping to support the safe passage of specific platforms.

The small size and modular configuration of the SWIMS not only make it possible for this system to be deployed on board a significant number of platforms, but also provide many nations the capability to adapt the system to their current helicopter fleet. This provides an Airborne Mine Countermeasure (AMCM) capability that, prior to development of the SWIMS, was possible only with the purchase of the MH-53E heli-

copter. It can be towed at speeds in excess of 30 knots and can operate in water depths less than 20 feet. The body contains a soft magnetic core wrapped with a coil that is continuously charged to maintain high magnetic levels at all times during the minesweep operation. The electronics required to support this system include five control boxes. With the addition of a laptop computer, the SWIMS can provide a ship emulation capability. This allows the system to conduct all types of minesweeping operations, be it sweeping generically against a specific threat or sweeping to support the safe passage of specific platforms. The small size and modular configuration of the SWIMS not only make it possible for this system to be deployed on board a significant number of platforms, but also provide many nations the capability to adapt the system to their current helicopter fleet. This provides an Airborne Mine Countermeasure (AMCM) capability that, prior to development of the SWIMS, was possible only with the purchase of the MH-53E heli-

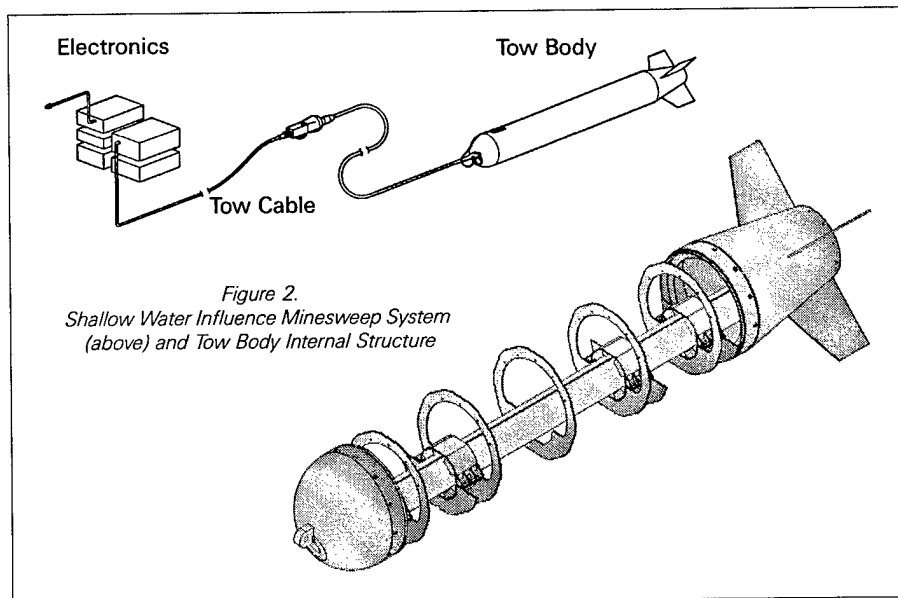
tured to provide high reliability and maintainability, and can be stored effectively with only minimum maintenance required. Within the Rapid Response Minesweeping concept, these advantages allow the MOLS and the SWIMS systems either to be stored at potential threat sites or to be packaged for quick transfer to a threat site from a central storage location. The ease of deployment and operation is critical to the success of this particular mission and timed responses should be in days, not in weeks. The modularity of these systems provides that timed response flexibility and enhances a national threat response posture that may help minimize the potential threat risk. These systems can be rolled on/off the designated surface platforms on a pallet, bolted to the deck, connected to the appropriate fuel or power source, depending upon the selected system and configuration, and then taken to sea. If towing from a helicopter, the configuration can be adapted for ease of installation and towed body launch and recovery.

### THE ECONOMICS OF RAPID RESPONSE MINESWEEPING

The presence of rapidly deployable mine sweeping systems in a national inventory is not just a military asset; it is a national economic asset as well. Most nations rely on the ability to transit safely across the world's sea lanes of communications and their economies are dependent upon that free trade. Closure of a major port of trade can have drastic results if allowed to continue for any length of time. It is imperative to small nation economies that the mine threat, whether real or merely threatened, be neutralized as quickly as possible. The presence of mine clearance assets that can immediately respond to these threats provides a greater security and minimizes the potential loss of shipping as well as the resultant economic impact. Costs associated with operations such as the escorting of tankers in the Arabian Gulf in the late 1980's are an example of the economic impact of a real and perceived mine threat, and highlight the need for organic national mine countermeasure systems.

### CONCLUSION

The deployment of naval mines will continue as a low-cost offensive weapon throughout the world. In the absence of total elimination of these weapons, one of the most effective methods for their neutralization is the rapid sweeping of the mine field. The ability to minimize the operational and economic impact of this threat can potentially deter the deployment and utilization of mines and is a positive step toward negating their use. Quick and effective response to this ever-growing threat can save lives and prevent damage and loss of shipping. EDO is proud to make available systems that help to reduce the naval mine threat and ensure free and open sea lanes of communication.



developed in response to recent difficulties in sweeping mines in the shallow water environment. The technical basis of this programmable, magnetic-influence sweep capability is the application of a dipole magnet, which is suitable for brackish and riverine environments, in a high-speed towed body. The design drivers for the SWIMS were the space and weight allowable for total containment within the cabin/ramp of the MH-53E helicopter during transit to and from the operating area. An additional benefit of this design is that it can be towed from helicopters significantly smaller and less expensive than the MH-53E, and also from small surface ships and very small, remote-controlled surface platforms.

The Shallow Water Influence Minesweep System towed body is 10 feet (3.05 meters) long with a diameter of 20 inches (50.8 cm), weighs approximately 1000 lbs. (455 kgm.) and uses an external 6 KVA

copter.

The benefits of AMCM have been demonstrated in every U.S. mine countermeasures operation since the clearance of Haiphong Harbor in 1973. This system, which is scheduled for operational testing under a U.S. Navy contract, can be available for production as early as FY98.

### RAPID RESPONSE MINESWEEPING OPERATIONS

The systems that make up the Rapid Response Minesweeping concept provide only half of the concept viability. The second portion of this concept is the operational deployment and positioning of the assets to maximize the system flexibility and minimize the required response time to a mine threat.

The Modular Open-Loop Sweep system and the Shallow Water Influence Minesweep system are designed and manufac-

# Implications of Single-Point, Mobile-Charge, and Distributed Wide-Area Architectures for Mine Warfare

Walter E. Dence, Jr.  
Naval Surface Warfare Center, Dahlgren Division  
Coastal Systems Station, Code A61  
6703 West Highway 98  
Panama City, FL 32407-7001 USA

**Abstract**—This paper examines the potentials of emergent mining sensor and sensor fusion technologies (1960-1996) for use in littoral water depths (50-200-m range). Offensive mining is developed in close cooperation with the mine countermeasures (MCM) community. This benefits both communities. It improves offensive mines, as well as MCM equipment and techniques. The focus of this paper is the impact of wide area mining to MCM in the far term. Today's MCM systems will be mature and will have been in the Fleet for many years when today's emergent mine technology is used. The scope of this paper is limited to offering a mine developer's viewpoint to the MCM community. Results are summarized from the most recent 35 years of mining and MCM development projects, demonstration tests, and war games. Applications include the Littoral Sea Mine (LSM), mine sweeping, mine hunting, ship self-protection, and distributed autonomous surveillance programs. Conclusions are that mining technology has the potential for effectiveness in littoral waters and that MCM efforts focused to a specific mine type will be the most effective.

## I. INTRODUCTION

Mining and mine countermeasures (MCM) are being revolutionized by recent technology developments sponsored by the Office of Naval Research (ONR). Mining is evolving from explode-in-place bottom and moored mines, to mobile-charge and wide-area mining. This begins to incorporate friendly minefields into the rapidly connecting environment of today's smart battlefield. These developments have far-reaching implications for MCM. Hull-borne vessels (including MCM vessels) caught inside smart wide-area minefields are at substantial risk.

MCM options include ship self protection, mine sweeping, hunting, and neutralization. Advanced degaussing, acoustic masking, mine avoidance sonar systems, and fleet readiness procedures are ongoing programs in ship self protection. Simulated ships versus large-range sweep equipment are competing approaches in mine sweeping. Finally, options for neutralization must consider auto-sterilization, remote command and control (RECO), identify friend or foe (IFF), passivation, sterilization by explosion, and dragging for distributed sensor links.

The mine designer begins with fleet requirements for minefields and targeted platforms. He selects candidate influences, measures and models the targets and the environment. Next, he develops

and models the sensors and the sensor fusing algorithms. The effectiveness of organic versus standalone MCM hunting needs to consider tradeoffs depending on the expected location of intermediate-depth mines (bottom, volume, or near-surface). The designer runs analyses with respect to many parameters. They are location, influences, sensor and mine layout, active emissions, range, delivery response time, MCM resistance, degradations due to storms (both wind-driven and geomagnetic), effectiveness against specific targets, cost, and the expectation of an encounter. Finally, the designer evaluates overall minefield effectiveness at the tactical and campaign levels. These analyses can show the "force multiplier" effectiveness of offensive mines.

Contents of this paper apply to the Littoral Sea Mine (LSM), mine sweeping, mine hunting, ship self-protection, and distributed autonomous surveillance programs. Conclusions are that mining technology has the potential for effectiveness in littoral waters and that MCM efforts focused to a specific mine type will be most effective.

## II. DEFINITIONS

Naval mines can be categorized as explode-in-place (EIP), mobile charge, and, more recently, wide area. This reflects the evolution of mines (the Civil War era) into torpedoes (WWII), with much of the post-WWII mine development effort devoted to mobile-charge mines (using encapsulated torpedoes.) More recently, research opportunities in underwater communications have refocused mining R&D efforts toward wide-area mining. This begins to bring mining into the network of the smart battlefield.

The EIP mine, Fig. 1, is cheap, very hard to find completely (for bottom mines due to burial, etc.), and has proven effectiveness [1]. It is commonly used in both bottom and moored forms. No human is needed to provide 24-hour operation, a force multiplier. However, the detection and damage ranges are limited ( $\sim\pm 50$  m), forcing the miner to produce, stockpile, maintain, and deploy many mines. This also limits the area that can be mined, forcing careful planning to ensure that the mines are planted where the high-value targets are going to sail.

In deeper waters (>50 m), EIP mines are often moored. In

## Explode In Place

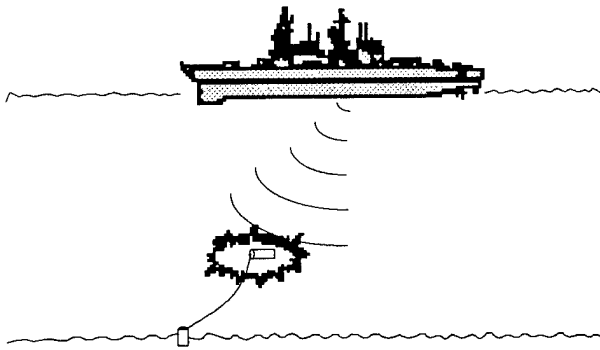


Fig. 1. Explode-in-Place Mine, Both Bottom and Moored.

in addition, in these deeper waters, required minefield widths are greater. For instance, in WWI, the North Sea Barrage planted more than 70,000 moored mines in 1918 [2]. This experience and the requirement drove the development of the mobile-charge mine, Fig. 2. This mine releases an encapsulated torpedo. It covers a larger range (up to a mile) than the range of an EIP mine (~50 m). This vastly reduces the number of mines required to be deployed to cover wide, deep minefields. This type of mine also has proven its effectiveness (in nonlittoral waters only), and like the EIP mine, requires no human intervention to provide 24-hour operation. In order to extend a mobile-charge capability to littoral waters, substantial R&D has been performed on the Littoral Sea Mine (LSM), and on the Improved Submarine-Layed Mobile Mine (ISLMM).

The limitations of the EIP mine to cover large littoral areas efficiently and affordably, and the lack of proven torpedoes and sensors for mobile-charge mines in shallow waters (50-200-m deep), is now driving technology development for mobile-charge and wide-area mines. Wide-area mines, Fig. 3, employ many networked sensors. They build on recent research results in the

## Mobile Charge

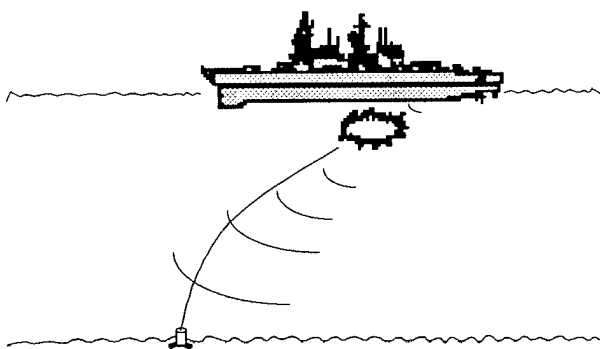


Fig. 2. Mobile Charge Mine, Both Bottom and Moored—Bouyant Rising, Encapsulated Torpedo, Rocket Propelled, etc.

## WIDE AREA MINE

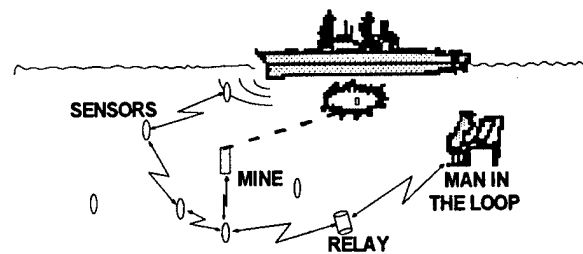


Fig. 3. Wide Area Mine, Deployable Autonomous Distributed Surveillance combined with a Long-Range Weapon

underwater communications, networking, and smart battlefield areas. Targets are detected, tracked, and targeted by using surveillance-based capabilities. Humans can monitor the minefield, and issue commands to arm or disarm it, based on actual wartime evolutions, not predicted ones.

The extremely wide, continuous sensor coverage allows the torpedo to attack over its full propulsion range (up to several 10's of nautical miles). Sensors may be in place at no cost to the miner, due to nonmining requirements from the surveillance community. For these reasons, only a handful of torpedoes may be needed to provide the required threat.

Because the wide-area minefield can be so large (hundreds of nautical miles), minefield avoidance may not be a practical option for the enemy. In addition, any hull-borne vessels (including MCM vessels) that get caught well inside the minefield are at great risk from attack from stealthy electric torpedoes. These can come from great distance, may be undetectable in shallow water, and can burst into high-speed attack when very close to the target.

Since wide-area mine sensors provide nearly continuous coverage, breakthroughs of the minefield by the enemy are unlikely. Finally, the wide-area minefield provides a dual-use capability to our forces, supporting both surveillance and mining requirements.

The benefits of mining from the miners point of view, for the various mine types, as indicated in the Section II, are summarized in Table I.

### III. IMPLICATIONS FOR MCM

Naval MCM involves various options in operations, platforms, and equipments. MCM operations can be categorized as intelligence gathering, reconnaissance, hunting, (detection, localization, classification, and neutralization), and sweeping. Platform options range from dedicated MCM assets to organic

TABLE I  
BENEFITS OF EXPLODE-IN-PLACE, MOBILE-CHARGE, AND WIDE-AREA MINES TO THE MINER

Explode in Place	Mobile Charge	Wide Area
Cheap, hidden.	Fewer required than EIP. (More than 70,000 moored EIP mines were planted during the North Sea Barrage in 1918.)	Only handfuls required. (The extremely wide, continuous sensor coverage allows the torpedo to attack over its full propulsion range. Sensors may be in place at no cost to the miner, due to surveillance requirements.)
Proven effectiveness.	Proven effectiveness in nonlittoral waters.	Active R&D.
No human needed for 24-hour operation.	No human needed for 24-hour operation.	Human in-the-loop required. (Part of the C <sup>4</sup> I smart battlefield.)  The enemy cannot avoid the minefield, even if found, because it may be too large to pass around. Any hull-borne assets (including MCM vessels), caught inside the minefield are at very high risk. Breakthroughs by the enemy are unlikely. Dual use (mining and surveillance.)

ship self-protection capabilities. Both manned and unmanned platforms are considered, due to the substantial dangers of operations in live naval minefields. Equipments are available to find and cut the cables of moored mines, to sweep and spoof influence-fired mines (using magnetic, acoustic/seismic, and pressure influences), and to find and neutralize other remaining mines, including some buried mines.

The selection of appropriate MCM options is strongly affected by the types of mines encountered, EIP, Mobile Charge, or Wide Area.

Since many EIP mines are needed to cover very large areas, it can be expected that such mines will be planted into definite minefield segments. Intelligence gathering and reconnaissance, therefore, are appropriate operations, since a lower-risk path through or around the minefield may exist. Alternatively, MCM operations can be focused to desired channels for the near-term, highest-priority needs, to provide cleared channels of adequately low risk.

Mobile charge mines combine detection, localization, and targeting sensors with a torpedo, etc., at a single location. The attempt to do these functions reliably from a single location (at the mine), can often result in the mine's use of an active confirmation (sonar). Organic MCM should therefore attempt to listen for such sonars, to capture the pings, and to try to avoid the mines and the minefield. Since mobile-charge mines are expensive per copy (not necessarily per minefield), it can be expected that there might not be many of them. It is therefore also worth considering to find or create gaps in the sparse line of mines. Then attempt breakthroughs in the low-risk lanes.

The essential technology that enables consideration of development of wide-area mining, is communication among sensors, master nodes, operational (OPS) centers, and weapons.

These communication links are required to be covert, jam-resistant, low-power, and reliable networks. Nevertheless, MCM options should attempt to detect inter-sensor communications. Use of unmanned or non-hull-borne platforms (helicopters, autonomous underwater vehicles, etc.) will reduce risk to humans.

Alternately, attempts may be made to jam the communication links. However, jam resistance is a design requirement of these networks, so this also may not be effective.

Another approach is to recognize that the number of weapons deployed into a Wide Area Minefield should be very small, even much less than the reduced number required for the Mobile-Charge minefield, (relative to an EIP field). MCM forces might consider hunting for the weapons, finding and neutralizing them. As before, use of unmanned or non-hull-borne platforms will reduce the risk to humans. If hull-borne platforms are used, MCM forces should listen to detect quiet attacking torpedoes. They should be prepared to employ anti-torpedo countermeasures if attacked.

Finally, MCM forces should consider that a Wide Area Minefield is very likely to include a man-in-the-loop OPS center. If this is the case, then finding and destroying this OPS center should be considered.

The implications for MCM from the miners' point of view, for the various mine types, as indicated in the Section III, are summarized in Table II.

#### IV. DISCUSSION

The options for naval MCM are varied—from manned hull-borne dedicated MCM ships, to unmanned, autonomous vehicles; from intelligence gathering to sweeping, hunting, and



TABLE II  
 IMPLICATIONS OF EXPLODE-IN-PLACE, MOBILE-CHARGE, AND WIDE-AREA MINES TO MCM

Explode in Place	Mobile Charge	Wide Area
Too many mines are required for extremely wide area mining. Relatively small and dense minefields.	Organic MCM—Try to capture pings and avoid the mines.	Try to detect inter-sensor communications with non-hull-borne platforms (helicopters, autonomous underwater vehicles, etc.) Jam communications.
Find the minefield segments, and avoid or counter mines in those areas.	Try to find/create gaps; then attempt breakthroughs in low-risk lanes.	Try to find and neutralize the small number of weapons (torpedoes). Listen to detect attacking torpedoes; prepare anti-torpedo countermeasures for use if attacked.  Find and destroy surveillance OPS Site.

neutralization; from cutting cables of moored mines, to hull-quieting to avoid actuations of influence mines. Study and knowledge of the various types of minefields affects MCM planning, and the options selected for MCM operations.

For EIP fields, the traditional, well-developed disciplines of intelligence gathering, hunting, and sweeping, are most appropriate. Yet for Wide Area minefields, these methods have serious deficiencies. In particular, the time required to find and identify the mines, and the extreme danger of hull-borne vessels that find themselves well within a Wide Area Minefield, substantially increase the consideration that should be given to unmanned, remote hunting and neutralization options.

#### V. CONCLUSIONS

EIP mines have relatively small (~50 m) sensor and damage ranges.

Mobile charge mines have a larger sensor range (<1 nmi), but this severely limits the potential propulsion range of an attacking encapsulated torpedo (~10's of nmi).

Wide area mines provide sensor ranges (~100's of nmi) that make the most efficient use of the potential propulsion ranges of torpedoes.

Hull-borne vessels (such as MCM ships, DD's, etc.) that find themselves well within the boundaries of wide area minefields, are at substantial risk from the attack of stealthy electric torpedoes. These can come from great distance, may be undetectable in shallow water, and can burst into high-speed attack when very close to the target.

Wide area minefields will contain far fewer weapons than EIP or mobile-charge minefields of comparable dimensions.

Wide area minefields depend heavily on communications technologies, and will include a man-in-the-loop.

#### VI. RECOMMENDATIONS

MCM forces should carefully monitor potential enemy capabilities for signs of wide-area mining.

MCM platforms deployed against wide-area minefields should emphasize air, or unmanned-remote vehicles, due to the substantial risk of attack from stealthy electric torpedoes.

MCM against wide-area minefields should consider interception and/or jamming of the minefield's communication links.

Since the number of weapons is predicted to be small, hunting and neutralization of the weapons should be considered.

Location and destruction of the surveillance OPS center may also be an effective tactic in reducing the threat from wide area minefields.

#### REFERENCES

- [1] *NAVSEA Mine Familiarizer*, Naval Mine Warfare Engineering Activity, Yorktown, VA, April 1985.
- [2] T. M. Melia, "*Damn the Torpedoes*" *A Short History of U.S. Naval Mine Countermeasures, 1777-1991*, Washington, DC: Naval Historical Center, 1991.

# HISTORY AND EVOLUTION OF MINEHUNTING TECHNOLOGY

Celeste Z. Hansel  
Coastal Systems Station  
Dahlgren Division  
Panama City Bch., FL 32407

**ABSTRACT** - This paper gives a brief history of minehunting by the U. S. Navy. Beginning with the development of sensors for mine detection, it traces the evolution of acoustic, magnetic and optic detection sensors. As minehunting experience expanded into more varied and critical environments, the need of more accurate sensors led to classification and identification sensors. Neutralization equipment and procedures have also evolved in recent years with the use of remotely operated vehicles (ROVs). The process of integrating these sensors and equipment into contemporary complex minehunting systems is described. Much of this paper focuses on the current minehunting capabilities and the history which preceded its development. Near term and future minehunting technologies are also briefly discussed.

## INTRODUCTION

Minehunting technology has evolved in response to the most recent conflict and evolving threats. The process we think of as modern minehunting began in World War II. The Germans developed bottom mines with magnetic, pressure and acoustic influence mechanisms. Mines had to be swept multiple times with different influence sweeps. This was a very dangerous and time consuming process which led to the need to find the mines so that they could be identified for sweeping, individually neutralized, or avoided. Various acoustic, magnetic, and optic sensors have been developed since World War II to aid in the minehunting problem. Many of these systems were one-of-a-kind concept demonstrations which were never produced in great numbers. Navigation technology has also played an important role in accurately locating mine positions during minehunting.

The objective of minehunting is to detect, classify, identify, and localize mines for neutralization or avoidance. Detection is determining if an object is present, either in the ocean volume or on the bottom. Classification determines if it is sufficiently minelike for further investigation. Classification decides if the object has the size and shape of expected mines. Identification resolves that it definitely is or is not a mine. Identification is generally done visually at very short ranges with a diver or underwater camera. Localization accurately determines the object's position and relies on the navigation

system. Each of these functions is an important part in minehunting. Today's minehunting systems have integrated detection, classification, identification and neutralization capabilities.

The dedicated minehunting platforms which are currently in the fleet are the MCM 1 and MHC 51 ships and the MH-53E helicopter. MCM 2 through MCM 9 possess the AN/SQQ-30 sonar for detection and classification and the AN/SLQ-48 Mine Neutralization System for identification and neutralization. The remainder of the MCM 1 ships and all MHC 51 ships have the AN/SQQ-32 sonar for detection and classification and the SLQ-48 MNS for identification and neutralization. This combination of sonar systems and Mine Neutralization System integrate detection, classification, identification and localization capabilities.

Airborne MCM is performed with the MH-53E helicopter towing the AN/AQS-14 side scan sonar which combines detection and classification into one sonar. Identification and neutralization are then performed by Explosive Ordnance Disposal personnel or MCM ships with Mine Neutralization Systems.

#### CURRENT MINEHUNTING CAPABILITY

The MCM 1 oceangoing minehunter, known as the "Avenger" class is built with a wooden hull covered by a thin coating of fiberglass. To date 14 have been commissioned. They are 224 feet long and were planned to address the blue water as well as coastal mine threat. They use the AN/SSN-2(V) Precise Integrated Navigation System (PINS) for navigation. Accurate shipboard navigation permits accurate localization of the mine for avoidance or neutralization.

The MHC 51 "Osprey" class minehunter coastal is built using GRP (Glass-Reinforced Plastic) construction. It is 188 feet long and with a slower speed, and shorter range was developed for coastal minehunting. The class is designed with modularized and interchangeable mine countermeasures equipment which permit the ship to perform one mission at a time. It uses an AN/SYQ-13 navigation command system.

The older AN/SQQ-30 minehunting sonar uses separate detection and high resolution classification sonars on different frequencies with separate displays and operators. It is a variable depth sonar with a hydrodynamic towed body which is stored in a well in the forward part of the vessel. The newer, AN/SQQ-32 advanced minehunting improves on the detection and classification capabilities of the AN/SQQ-30. The system displays search and classification information simultaneously and independently, using separate transducers in a stable, variable-depth body. The AN/SQQ-32 can operate at greater depths than the AN/SQQ-30 and at higher speeds.

Mine identification and neutralization are performed using the AN/SLQ-48 Mine Neutralization System. It is a remotely operated, unmanned vehicle with a forward looking sonar and a low-light TV. Once a mine like contact is detected and classified, the MCM or MHC can remain a safe distance away and send in the Mine Neutralization Vehicle for identification. Information from the vehicle's sensors is sent back to the ship via the vehicle tether. The forward look sonar is used to vector the MNV to the moored or bottom target and the television camera is used for identification at very close range. The MNV carries a cable cutter to cut mooring cables and allow the mine to float to the surface where it is neutralized or recovered. It also carries a bomblet which it can drop on a bottom mine. The bomblet is acoustically activated after the MNV has safely returned to the ship.

Use of the MNS improves the safety of minehunting, by allowing the MCM to identify, and neutralize at a safe distance, however there is still the danger of drifting into an undetected mine.

An MH-53E Sea Dragon helicopter towing the AN/AQS-14 minehunting sonar can also be used for detecting and classifying mines at a relatively safe distance. The AN/AQS-14 airborne sonar consists of three components; an active stabilized underwater towed vehicle, an electromechanical tow cable, and airborne electronics console. The multibeam side-looking sonar employs electronic beam-forming technology to provide focusing over the sonar range coverage. The adaptive processor allows hand-off operation through varying bottom reverberation environments. Two operators man the control-monitor console onboard the helicopter. The unit includes a television moving-window sonar display, underwater vehicle controls and status displays, system status indicators, magnetic tape recording for sonar and other mission data, tape playback and controls, and the built-in test equipment controls and displays. A duplicate console is used shoreside for additional post mission analysis. System functions cover all tasks needed to locate, classify, mark, permanently record and review records of mines, mine-like objects and underwater terrain features.

## MINEHUNTING HISTORY TIMELINE

The first true modern minehunting effort evolved during World War II. The Germans developed mines which rested on the bottom and could not be spotted from a bow watch or the air. They also developed magnetic, acoustic and pressure influence mines. A minefield containing some of each of these influence mines would have to be swept multiple times with different types of influence sweeps. There was great danger in sweeping a minefield with only one type of sweep at a time. If you were sweeping with a

magnetic sweep, you were vulnerable to pressure and acoustic mines. Also in the time it would take to sweep and resweep, you could not clear an area in a timely manner. This led to the need to find the mines (detection), locate their exact positions (location), and if possible identify what type of mine they were (identification).

Active hunting of minefields required integration of emerging sensor and navigation technology. The most promising mine detection sensors were sonars and magnetic detectors. One FM sonar designated QLA was developed at the Navy Electronics Laboratory in San Diego California. It was originally developed and installed on submarines for AntiSubmarine Warfare (ASW) and was used successfully to detect and avoid floating mines. The Harvard Underwater Sound Laboratory developed several versions of a short-pulse electronically scanned sonar. They were called the Underwater Object Locator (UOL) Mk I through IV but were not successful enough to be deployed during the war. These early models used a variety of techniques including: pulse, cw multifrequencies, A-scan (amplitude vs. range), B-scan (range vs. bearing with intensity modulation), C-scan (elevation vs. bearing with intensity modulation), sector scan and stereo operation. The Mk IV was a pulse sonar and is considered the beginning of the approach presently used by current minehunting sonars.

During the Korean war the UOL Mk IV was replaced by the AN/UQS-1 minehunting sonar which was installed on all the MSOs and MSCs. The AN/UQS-1 was a hull-mounted sonar and more than 120 units were produced.

In the 1950's, sonar technology significantly evolved. Detection sonars were improved and new sonars were developed to address the problems of classifying mines. Because the AN/UQS-1 was hull mounted, mine detection problems often occurred when adverse sound velocity gradients were encountered. To overcome this problem, the AN/UQS-1 soundhead was mounted on an articulated strut and redesignated the AN/SQS-15, the first variable depth minehunting sonar. It was during this time that it was recognized that higher frequency sonars provided better resolution of targets. The U.S. contracted with General Electric to develop the CXRP high-frequency classification sonar. This sonar was evaluated in 1957 and 1958 and found to be effective as a classification sonar. It was used with the lower frequency detection sonar which had a much longer range. Since this time, U.S. minehunting ships use lower frequency detection sonars for initial detection and separate higher frequency classification sonars to classify at shorter ranges.

In 1960, the AN/SQS-15 and CXRP evolved into the AN/SQQ-14 sonar that combined the detection and classification sonars in a single variable depth system. The AN/SQQ-14 was the primary shipboard minehunting sonar for the next 25 years. Identification and neutralization at this time were mainly performed by EOD divers. In the

late 1960's the moored and bottom mines typically used during World War II, evolved into a deep ocean mine threat. The AN/SQQ-14 was modified to operated at deeper depths and evolved into the AN/SQQ-30 which began production in 1984. With more improvements and updated electronics it has evolved the AN/SQQ-32.

Going back to the 1950's and following another evolutionary trail, the C-Mk-1 Shadowgraph sonar was developed. It was a very high-frequency, high-resolution, short range sidelooking sonar in which detection and classification would be done with the same information. The C Mk-1 used a line transducer with a radius of curvature equal to the height above the bottom so that the transmit and receive beams were in focus at all ranges in a line along the bottom. It produced very high resolution displays of the bottom and was used for channel mapping by the Navy Oceanographic Office. The C Mk-1 was the first sidelooking sonar and eventually led to the development of the AN/AQS-14 for use with helicopters. The AN/AQS-14 was evaluated in 1971, has undergone several modifications, and is in use today.

During the clearing of Wonsan harbor, aircraft and helicopters were used to spot mines from the air. Helicopters were also used for marking minefields with buoys. Throughout the 1960's and 1970's helicopters were increasingly relied upon for minehunting and minesweeping capability. Airborne MCM assets are well suited for rapid response and contingency operations and play a major role in today's minehunting resources.

Navigation technology has always been an important factor in minehunting effectiveness. Since World War II, bouys have been used to mark minefields and cleared areas. Range measuring systems, differential range measuring systems and azimuth or radial systems have all been developed and evaluated over the years for minehunting navigation. These systems all required a fixed accurately known position and suffered to varying degrees when it was lacking. Today's minehunting platforms use integrated command and control systems, the AN/SSN-2(V) PINS on the MCM 1 class and the AN/SYQ-13 on the MHC 51 class ships. PINS uses the TRANSIT SATNAV system to provide navigation fixes, interfaced via PINS with the ship's Doppler sonar operating in either ground speed or water speed modes. Other interfaced systems include LORAN C and Hyperfix.

## MINE COUNTERMEASURES SHIFT IN FOCUS

The current MCM emphasis is to develop a capability to rapidly respond to critical littoral situations. This is being done by building an organic minehunting and neutralization capability in carrier battle groups and amphibious ready groups that enable

them to conduct mine countermeasures operations enroute to an objective area. Organic MCM will consist of smaller unmanned autonomous and semi-autonomous platforms for minehunting and reconnaissance. These small platforms can be quickly transported where they are needed throughout the world and may be supported from a number of non-MCM platforms.

Several systems presently available in limited numbers as deployment contingencies are the Remote Minehunting System and Magic Lantern mine detection system. In addition, the next evolution of the AN/AQS-14 airborne minehunting sonar, the AN/AQS-20, is currently being developed.

These systems attempt to solve some of the next generation of technical problems. These problems include integration of multiple sensors and data fusion, realtime processing and storage of large amounts of data, computer aided detection, classification, and identification, autonomous vehicle control, and high data rate, secure communications.

One organic system currently being developed is the Remote Minehunting System. It is to provide battle groups and individual surface combatants with an organic means of detecting and avoiding mines. The remotely operated system, using computer aided detection and precise navigation systems will detect and classify mines and their locations for avoidance or subsequent removal. The system is designed to be air transportable to forces anywhere in the world.

The RMS is a high-endurance, offboard, low-observable system launched, operated, recovered, and maintained from a host ship. It uses acoustic sensors housed in a variable depth underwater body for detection, classification, and localization of mine-like objects. All equipment needed to perform data processing, display, recording, and mission analysis functions are transported with the RMS and installed on the host platform. RMS (V)1 completed a concept demonstration in October of 1994 and participated successfully in Kernel Blitz '95 as a reconnaissance asset aboard the USS *John Young*, DD-973.

Magic Lantern mine detection system has been tested in the Gulf of Mexico. It is a light detection and ranging system located on the MH-53E helicopter. It emits short blue-green laser pulses into the water. Direct reflections or shadows are received by six electronically gated image-intensified cameras, each focused on a different depth. The system can detect, classify and localize mines in surf and landing craft/ beach zones. Due to the large amount of received data, Magic Lantern utilizes real time Automatic Target Recognition (ATR), providing the operator with processed detection/ classification information rather than displays of sensor data.

The AN/AQS-20 is the next evolution of the AN/AQS-14 airborne minehunting sonar. This system will be towed by an MH-53 helicopter for detection, classification, and marking of tethered and bottom mine-like objects. The AN/AQS-20 integrates multiple sonars, a side scan sonar for bottom mines and forward look sonar and volume search sonar for tethered mines. The addition of gap filler sonar increases the area coverage rate over the AN/AQS-14. Computer Aided Detection (CAD)/ Computer Aided Classification (CAC) assist the onboard operators. An existing onboard navigation system will be integrated for precise location of sonar contacts. A real-time data link will transmit and receive data between the helicopter and a remote command control center.

## FUTURE MINEHUNTING TECHNOLOGIES

There are several acoustic, magnetic and electro-optic technologies being advanced at CSS. Two of interest are the Synthetic Aperture Sonar and Laser Line Scan Sensor technology

An acoustic system which shows promise is the high-frequency/low-frequency synthetic aperture sonar is being developed to detect, classify, and identify mine-like targets in shallow water and very shallow water regimes. The low frequency SAS is expected to be able to detect and classify volume, proud, and buried mines with its 3" x 3" resolution. The high frequency SAS with its 1" x 1" resolution is expected to have an identification capability approaching that of some optical systems. The high-frequency/low-frequency SAS was designed to be small, light weight, for use on unmanned underwater vehicles (UUV).

The side scan Synthetic Aperture Sonar concept exploits vehicle motion to produce a long virtual line array in space. A small single transducer transmitting at a certain rate along track will build a coherent history of past reflections in a digital memory. When a sufficient number of samples have been recorded at each range cell, they can be coherently combined to produce a synthetic aperture beam perpendicular to the direction of travel. The beamforming process is very similar to that required for a conventional multistave line array. Early proof of concept demonstrations of synthetic aperture sonars were conducted in December of 1992 and in September 1995 at the Mobile Underwater Survey System Feasibility Demonstration.

Current underwater imaging systems, consisting of a video camera and floodlights, are generally limited to ranges of several meters in coastal water. Imaging systems used today, for example the MNS, rely on an operator in the loop to correctly identify mines which excludes their use on fully autonomous vehicles.



Primary limitations in the range and resolution of underwater imaging sensors are scattering and attenuation. Scattering leads to loss of image resolution and contrast and attenuation reduces the signal strength at the receiver.

A Laser Visual Identification Sensor approach (LVIS) being advanced at CSS is the laser line scan (LLS). The LLS system employs a CAW blue/green argon ion laser. A rotating, four-faceted mirror and output optics assembly scans the laser beam over a 70-degree section of the sea bottom while a synchronously rotating four-faceted mirror and input optics assembly focused the reflected light onto a photomultiplier tube receiver. Simultaneously, the scanned lines are processed as acquired and presented in a gray-scale waterfall display on the operator console.

# MCM APPLICATIONS OF A VIRTUAL ENVIRONMENT BASED TRAINING SYSTEM FOR ROV PILOTS

Barbara Fletcher

Imetrix, Inc.  
1235 Route 28A P.O. Box 152  
Cataumet, MA 02534-0152 USA

## ABSTRACT

In order to be effective, mine countermeasure (MCM) operations using remotely operated vehicles (ROVs) require highly trained and experienced pilots. Due to the expense and logistics involved with operating actual systems such as the Mine Neutralization System (MNS) and other ROVs of opportunity, training and practice is often difficult to obtain in other than an "on the job" fashion. Under the Department of Defense Focused Research Initiative "Training for Remote Sensing and Manipulation (TRANSoM)", an ROV pilot training and mission rehearsal system is being developed incorporating Intelligent Tutoring System (ITS) techniques within a Virtual Environment (VE).

Mission analysis yielded a set of general skills to be taught including maneuvering, situational awareness, sensor data integration, and mission operations. Unlike the current MNS trainer developed by NCSS Panama City, the TRANSoM system addresses general skills required for ROV piloting, rather than the specific procedures required for the MNS. Use of VE technology permits simulation of a wide range of environments, vehicle configurations, learning aids and mission scenarios.

The prototype training system is a VE-based Intelligent Tutor which implements various training aids and interventions to promote the development of both the sensorimotor and cognitive skills related to basic maneuvering tasks and situational awareness. Scenarios related to MCM tasks are being incorporated in the overall training curriculum. Once implemented, the training effectiveness will be evaluated by analyzing pilot performance on an actual ROV under various control conditions.

## OVERVIEW

### Navy Needs

The Navy is currently using or investigating the use of ROVs in a wide variety of applications including search and salvage, hull husbandry and mine countermeasures (MCM). An area of particular concern is that of shallow water MCM. Events over the past decade, particularly those in the Persian

Gulf, have highlighted the need for effective shallow water MCM techniques: the ability to locate, identify, and neutralize mines in 30-1000 feet of water. In this highly challenging environment, detection ranges of conventional sensor systems are severely compromised. ROVs are capable of bringing to bear capable, albeit short-range, sensor systems for detection and classification. In addition, these systems also provide a ready platform for tagging or neutralization devices. To increase area coverage, multiple vehicle systems are being considered, presenting a complex and challenging task for the operators. For effective utilization of these systems, tools are required to both train operators and provide for mission rehearsal and planning. The TRANSoM system provides a variety of these tools in a system designed for ready use in dynamic applications.

## The Program

Imetrix, Inc. is the prime contractor for the 5-year Department of Defense Focused Research Initiative program "Training for Remote Sensing and Manipulation (TRANSoM)". This program will design, develop, and evaluate a prototype remote platform pilot training and mission rehearsal system incorporating Intelligent Tutoring System (ITS) techniques within a Virtual Environment (VE). Efforts are concentrated in five main areas, all of which are critical to the overall development of the training system: task analysis, virtual environment and human-machine interface development, intelligent tutoring system development, training and system verification, and technology development and transition. This system will be demonstrated for the operation of remotely operated vehicles (ROVs) in a shallow water mine countermeasures (MCM) mission. The variety of skills required for successful ROV operation, including both sensorimotor and cognitive tasks, provides a unique opportunity for combining the strengths of ITS and VE techniques and technologies.

## TRAINING APPROACHES

During the Task Analysis, current vehicle systems and training techniques for mine countermeasures were examined in addition to determination of the overall mission requirements and training needs for general ROV piloting.

### **Current Mine Neutralization System (MNS) Training**

A critical part of the task analysis was the participation in a 3 day MNS Training Course, conducted at the Naval Coastal Systems Station in Panama City, FL, coordinated through Ms. Patty Mausert, and taught by Chief Bob Cashman, USN. The training involved use of the MNS simulator, part of the Combat Systems Integrated Training Equipment (CSITE), which includes other MNS related stations including the shipboard sonar and navigation stations. The MNS station includes positions for two operators: the vehicle pilot and the sonar operator.

While an effective tool for training MNS-specific characteristics and procedures, the CSITE system suffers from attributes typical to embedded trainers and simulators: it uses actual ships systems, requires a human instructor, and is not readily configurable to alternate mission or vehicle scenarios. The need for using the actual shipboard components severely limits the access available to trainees, as well as adding to the maintenance requirements of the systems. Since a human instructor is required for performance feedback, independent use of the system is limited further. Finally, the system is "hard-wired" for the MNS system and mission, limiting its expansion to other potential missions or environments.

Overall, the CSITE training provided important information about both general ROV piloting operations and features specific to the MCM mission. Through this experience, the team gained information on: a) environmental constraints and demands on performance, b) Navy requirements on skills and performance levels, c) techniques and methods used by an experienced Naval MNS instructor, and d) data on trainee performance and evaluation. While the MNS simulator is specific to the both the hardware and mission procedures, it did provide valuable insights on both the overall training and MCM specific tasks. Use of the TRANSoM system could supplement this trainer by providing off-line practice of more generalized skills without tying up ships' systems or human instructors.

### **TRANSoM Training Approach**

Rather than train a specific system and set of procedures, the TRANSoM system looks to train the general skills required by an ROV pilot in a generic, transferable fashion. These skills have both sensorimotor and cognitive attributes which must be addressed in the system. The most critical skills identified are in the following areas:

Maneuvering is the ability to drive the vehicle to a desired location and orientation. In order to maneuver the vehicle effectively, the operator must incorporate an understanding of the vehicle configuration, momentum, drag, effects of the controls, as well as basic hand-eye coordination.

Situation Awareness is the overall knowledge of what the status of the vehicle is, the location of the vehicle and tether within the environment, and the status of the mission progression. With a tethered system, understanding and having a mental model of where you've been, where you are and where you're going is the most vital skill for successful operation.

Sensor Integration is the ability to interpret the available sensor information and to piece together the whole picture. While many different sensors are used in conjunction with ROV missions, instruction and practice is required in order to effectively use the available information. Sensor related skills range from the intuitive use of video to the more cognitive skills of interpreting sonar and navigation data.

Mission Operations skills include the knowledge of the variety of systems often used in conjunction with ROV operations. Key to the success of any mission are the abilities to plan trajectories, manage multiple tasks, communicate with other operators, and develop effective team coordination.

### **TRANSoM SYSTEM DESCRIPTION**

The TRANSoM system is intended as a generic, configurable trainer for a variety of ROV configurations and mission scenarios. It consists of three main parts as shown in Fig. 1: the ROV system including the on-board sensors and controls, the Intelligent Tutoring System (ITS), and the Virtual Environment (VE) implementation.

#### **ROV System**

There are many common ROV system components used across the range of missions examined. The most common have similar control configurations (i.e.: joystick driven, switch activation of sensors) and general operational characteristics. Sensor suites vary from mission to mission, but video is universal with both tracking and sonar systems widely used. This general commonality of system components, combined with the versatility of the VE technologies and techniques, makes it possible to devise a training system that can be used for a wide range of system configurations. For the TRANSoM system, a representative physical ROV system has been built and modeled for use in system verification and training transfer tests (fig. 2).

Vehicle modeling includes both a realistic graphical depiction of the vehicle and a complete dynamic simulation. Both the dynamics of the vehicle and the tether are incorporated, so as to closely approximate the actual behavior of the system. Use of the VE allows a full range of vehicles to be simulated, not tying the training system to any single ROV.

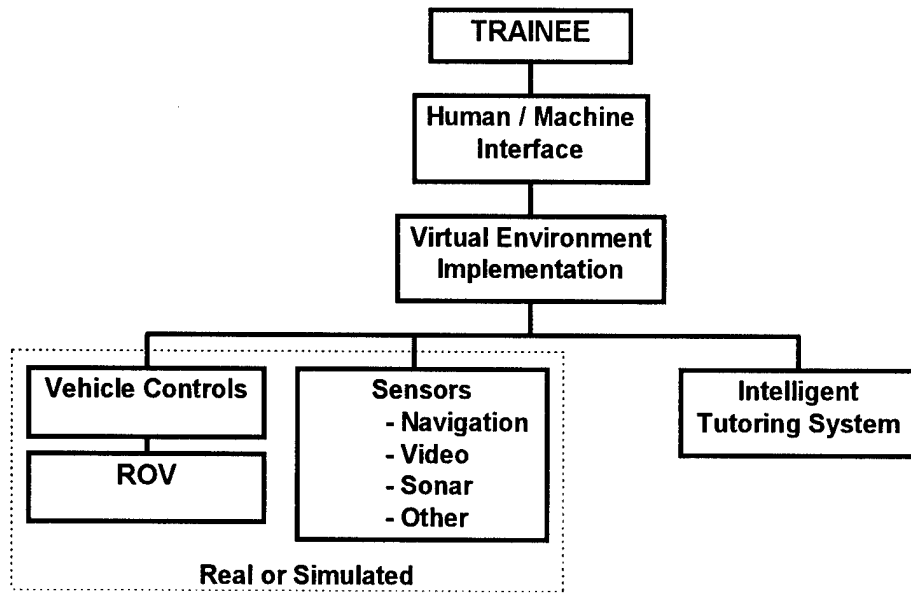
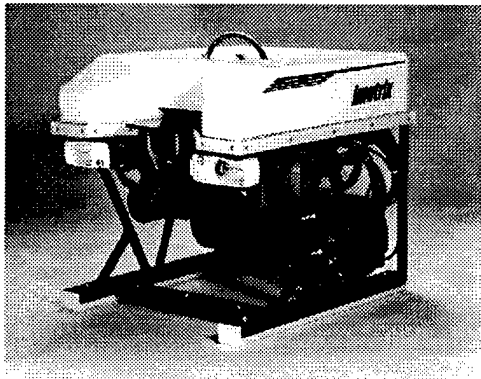


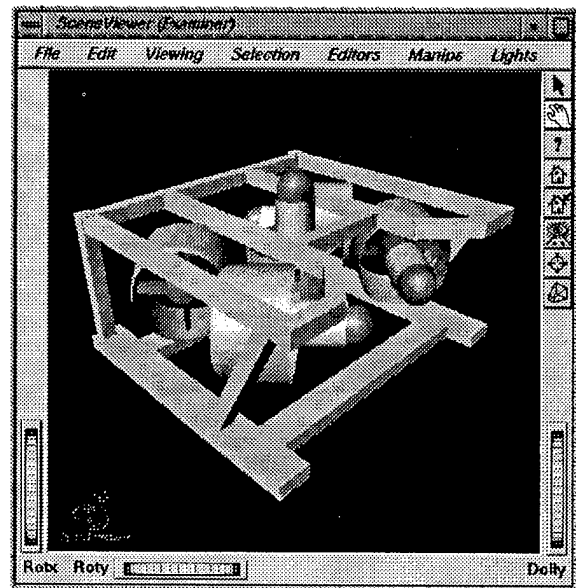
Fig. 1: Training System Components

$$(1) \quad Mv + C(v)v + D(v)v + g(\eta) = \tau$$

**Dynamic Model**

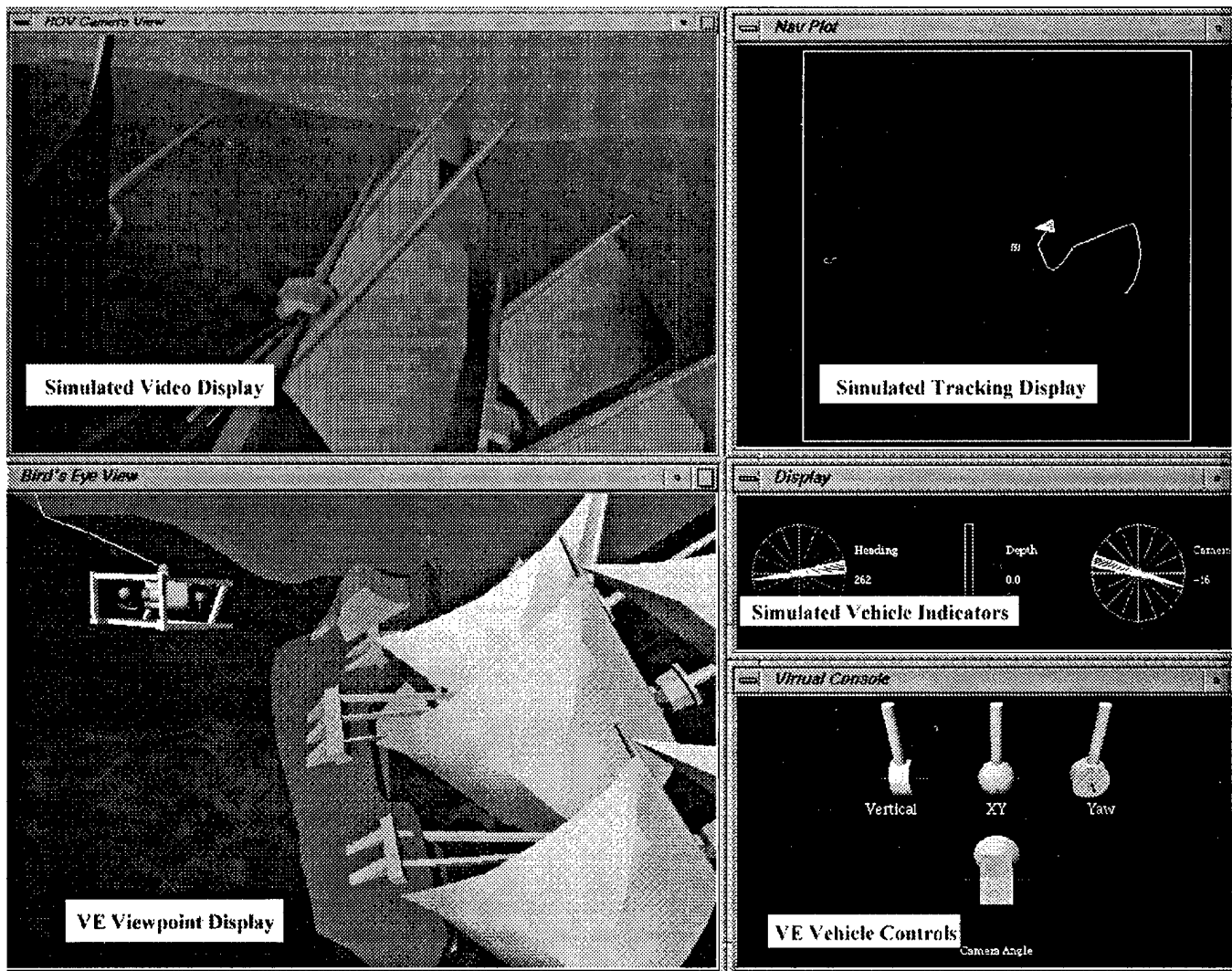


**Imetrix Talon ROV**



**Graphic Model**

Fig. 2: Physical and Simulated ROV Model



**Fig. 3: Typical Training Screen Layout**

Sensor modeling includes the simulation of sensor displays and their controls. As with the vehicle, a wide variety of sensors can be modeled and presented in simulation. The current training system includes a basic tracking display and vehicle video. The video simulates many characteristics found in actual systems including tilt, zoom, lighting, and the effects of poor water visibility. Future sensor additions will include a basic scanning sonar model to permit the training of multi-sensor systems.

Displays: The VE not only provides the models for the training environment, it also provides the means to display those models to the user. Currently, the training system described uses a flat panel display simulating typical vehicle sensor displays with the addition of VE models to serve as training aids. Figure 3 shows a general screen layout of the

display components. Alternate techniques including head mounted displays, see-through head mounted displays, and wide screen displays are being investigated for use in the system as instructional aids to promote skill learning.

### **Virtual Environment (VE)**

The VE techniques and technologies provide the medium for operation of the training system. Its flexibility allows for both the simulation of actual system components and the addition of aids not otherwise available. It provides the models to create the simulated world and also provides the medium for the implementation of the training system, providing the cues and guidance required by the student. It also provides the overall human / machine interface, the

displays and the means for the user to see and interact with both the simulated world and the training system.

**Models:** A number of models must be built to create a realistic training scenario. These include the environment, the vehicle, the sensors, and the specific training aids required. A wide variety of desired operating environments can be created, ranging from a simple training configuration to a complex mission rehearsal scenario. Existing models and data files such as AutoCAD models can be used to build realistic representations of actual operational areas.

**Training Aids and Interventions** use some unique capabilities of the VE to implement the training interventions described below. The ability to show varying viewpoints of the ROV's position within the environment is a powerful tool for guiding the student in proper operation. The VE itself can be used as an aid; for example, additional models may be created to serve as examples, displays may be highlighted, messages posted, verbal instructions given, all within the training scenario.

**Additional Modalities:** In addition to the traditional visual displays, VE technology offers additional modalities with the capability of providing a fully immersive environment. In

this system, both auditory and tactile modalities are being investigated for their effectiveness in training and performance. Verbal coaching is used, permitting the trainee to receive instruction without causing distraction from the existing visual displays. Use of spatialized audio cues indicating the direction of thrust is being investigated as an aid to understanding the system response to input commands. Experiments are exploring the use of haptic (force feedback) cues for learning system response and position.

### Intelligent Tutoring System (ITS)

There are three main components to the design of the training system: developing the curriculum of what is to be taught, determining how it will be taught, and developing the tools to aid in the teaching process. The training element is a form of computer aided instruction known as an Intelligent Tutoring System (ITS). This system uses a variety of training aids and interventions to coach the student and guide his progress. Figure 4 shows the basic system configuration.

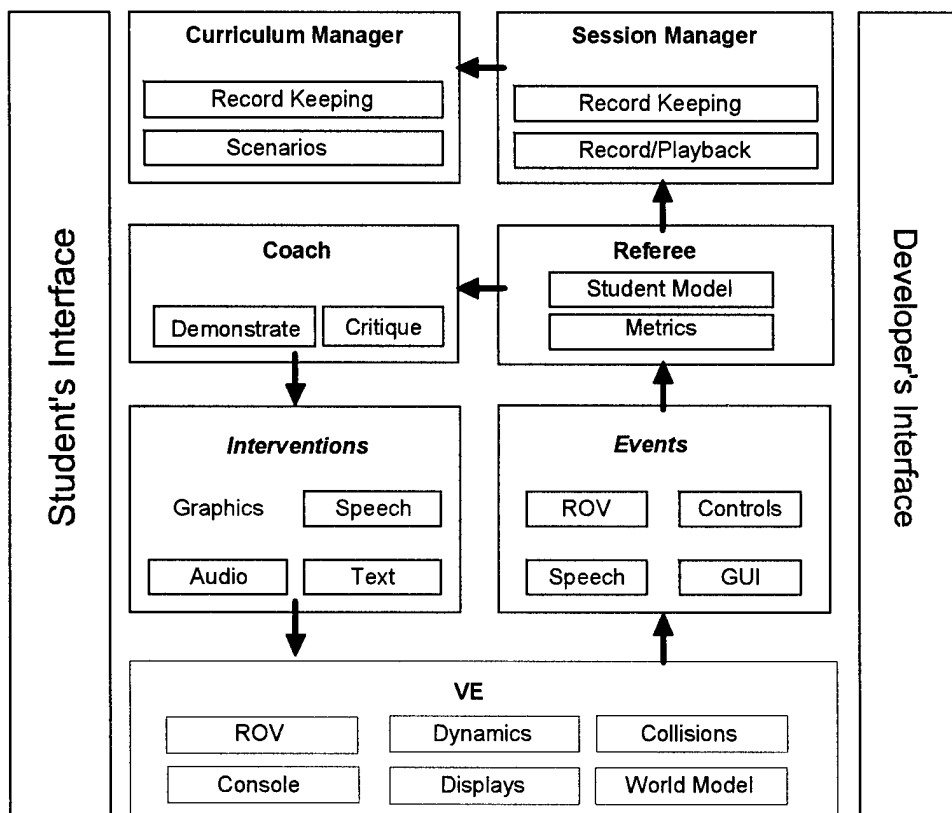


Fig. 4: Intelligent Training System Structure

**Curriculum:** Based on the Task Analysis, a series of curriculums are being developed to teach the essential piloting skill. These provide guided trials through a defined series of skills, until the operator is deemed proficient. The curriculum, used with the ITS, permits the difficulty level presented to be adjusted for the competence level of the student. The ITS is built on a knowledge of expert performance, against which the trainee is judged. A variety of performance measures are used to quantify the trainee's progress, and to adjust the curriculum accordingly.

**Training Scenarios:** A typical training session will entail the trainee sitting at the console and operating the vehicle simulation in the VE. Fig. 3 shows the typical screen configuration used by the student, incorporating the simulated sensor displays, vehicle controls, and VE training aids. The operational sequence followed by the trainee would proceed as follows:

1. *Introduction* is where the task is named and explained, using visual aids and sample displays as necessary. For example: "Transit from point A to point B"
2. *Demonstrations* are pre-programmed task segments shown to the trainee, using the simulation capabilities of the VE. Pertinent skills and performance parameters are highlighted by the Tutor, alerting the trainee to the focus of the exercise.
3. *Practice* allows the student to perform the task, with interventions by the Tutor as required. As the student gains proficiency, these aids are faded out, permitting the student to operate independently. For example the 3D view is an artificial aid to operation which is faded out as the trainee becomes proficient in using the standard ROV displays.
4. *Playback and Critique* allows all or part of the session to be replayed, with accompanying notation as to errors made. During the playback, the student may re-enter the simulation, in an effort to correct individual mistakes at the time that they were made.
5. *Repetition* of the Practice and Playback steps are performed until the student demonstrates the desired level of performance. At that time, the task may be modified to make it more difficult or to include additional tasks.

**Aids and Interventions:** Chosen from traditional classroom techniques, computer aided training and from VE-unique capabilities, a variety of training aids and interventions are being incorporated in the training system. These include the following:

1. *Demonstrations* are programmed mission segments which illustrate particular skills to be learned. The system offers a variety of ways to demonstrate to the trainee the desired behavior. For example, flying the

ROV model along a planned path and indicating proper control inputs is a way of demonstrating use of the joystick.

2. *Visualization Aids* are visual cues that are provided to draw attention to particular items and to provide additional information to the operator. The 3-D VE views offer a unique ability to provide the operator with a variety of viewpoints including a bird's-eye view, over-the-shoulder, and side-on views. Other aids include marking of the actual and desired path, enhanced visibility, and added environmental cues, such as current flow indicators.
3. *Feedback* is a key part of any instructional system, providing information to the trainee as to the progress being made in learning the desired skills. This can be provided by verbal coaching and querying, verbal or visual warnings, and providing an on-going performance metric to the operator. Other types of feedback being investigated include self status aural indications such as the sound of thrusters or collisions.
4. *Replay* of a session or sequence permits the trainee to observe his actions. The computer based system not only allows a training scenario to be replayed, but also restarted at critical points for training of proper operation. Replaying the session also provides an opportunity to present additional information relating to the performance of specific tasks.

### **Training and System Verification**

The true test of any system is how it works in the real-world under actual operating conditions. For this system, a variety of tests are planned ranging from verification of the simulation performance to measuring the effectiveness of the training system.

**System Verification:** The first step in testing is the verification of the simulator relative to an actual ROV system. For this purpose, the Imetrix TALON ROV will be used. Characteristics of this vehicle have been incorporated in the simulation, and the simulated behavior will be compared with actual vehicle dynamic behavior under a series of controlled operations.

**Formative Evaluations:** As various training interventions are implemented, they are continuously being evaluated through a series of small scale tests. Formative evaluations use small groups of test subjects to study the effect of certain training interventions. Examples to date have included the design and use of the varying 3-D viewpoints and the analysis of verbal coaching strategies.

**Training Transfer:** In order to verify the effectiveness of the training system, continuing experiments are planned to determine how the skills taught in simulation transfer to the operation of an ROV under actual operating conditions. This will be done with the Imetrix TALON. Trainees will be

given the opportunity to demonstrate their proficiency on both real and simulated operations to test the effectiveness of the training. Their performance will be compared to various control groups including both expert and novice ROV pilots.

## **MCM APPLICATIONS**

The TRANSOM system also provides critical capabilities for remote operations beyond the initial ROV and MCM training functions.

### **Near-term MCM Systems**

In recent years, the Navy has funded the COOP (Craft of Opportunity) and MMUROV (Multi-Mission Remotely Operated Vehicle) programs, utilizing the smaller (200-400 lb), less expensive (\$150,000 to \$300,000) vehicles which are now commercially available. This type of system is intended to be deployed on a widespread basis, using both vessels and crews of opportunity (Reserves, Merchant Marines, etc.). To be used effectively, this requires training techniques that are equally flexible and widespread. The TRANSOM system addresses these needs on several fronts: it is configurable for a variety of vehicles and mission scenarios, it trains a full range of skills from basic maneuvering through complex mission procedures, it does not require dedicated equipment or instructors, and it is based on a stand-alone low-end computational platform.

### **Mission Planning**

The simulation capabilities inherent in the TRANSOM system provide a strong basis for mission planning and rehearsal. Use of the VE-based system allows development of a wide variety of scenarios for determination of system deployment techniques, optimal path planning, and overall mission rehearsal. In this way, various approaches may be tried without risk to personnel or high value assets. In addition to the MCM applications discussed here, systems such as the Advanced Hull Maintenance Vehicle under development by the Naval Surface Warfare Center also have need of these capabilities.

### **Multi-vehicle Systems**

Many of the future MCM applications envision use of multiple vehicle systems working in concert. The command and control strategies for such multi-vehicle systems are currently in very early, conceptual stages. The TRANSOM system provides an easily configurable operational test-bed for developing and evaluating control schemes and strategies

without the need to field expensive developmental hardware. Once such systems are fielded, the TRANSOM system will provide an integrated means of operation and control.

### **Autonomous Systems**

Many of the multi-vehicle systems envisioned will exhibit varying degrees of autonomy from direct human control. In addition to the mission planning and control capabilities described above, the TRANSOM system can also provide a means of visualization during actual operations. By integrating what sensor data is available with the planned mission scenario, TRANSOM can provide the operations personnel with an overall view of the mission progression.

## **SUMMARY**

A training system is currently being developed for the training of ROV pilots incorporating virtual environment technologies. Use of the VE permits great flexibility in terms of the mission scenarios, vehicle configurations, and training aids. The technologies and systems developed within this program will be transitioned into other military and commercial arenas such as surveillance, hull inspection, structure inspection, and telepresence training systems. Further information may be found on the Web at:

<http://man-ray.mit.edu/www/Vetrec/TRANSOM/project.html>  
and <http://www.imetrix.com>

## **ACKNOWLEDGMENTS**

The work described in this paper is funded by the Office of Naval Research. The authors would like to thank Dr. Terry Allard and Dr. Harold Hawkins for their continued support. This work is being done as a collaboration of four organizations, each of which contributes a unique component to the effort: *Imetrix Inc.* is the prime contractor, overseeing the effort, providing the ROV system and control expertise, and the main conduit for product transition, *Massachusetts Institute of Technology* is providing the lead in human/machine interaction research and virtual environment technology, *McDonnell Douglas Training Systems* is providing expertise in ITS design and leading the training transfer studies, and *BBN Inc.* is developing the ITS and providing training research and evaluation support, with *Learning Research and Development Center* providing training expertise under subcontract.





## **Clandestine Reconnaissance in Very Shallow Water with a Mine Reconnaissance Underwater Vehicle**

CAPT Dan Hendrickson, USN (Ret)

The Mine Reconnaissance Underwater Vehicle (MRUV) Project was initiated in response to an Oct. 92 request from Commander Naval Special Warfare Command for a small, low cost reconnaissance UUV which can be remotely operated from SEAL Delivery Vehicles (SDV) and small craft.

The remotely operated MRUV would have sufficient endurance to survey a 500 yard wide x 2,000 yard long amphibious assault lane in less than 2 hours. It would be equipped with depth, altitude, sonar and optical sensors to conduct a hydrographic and mine reconnaissance in the 10 to 40 foot deep Very Shallow Water (VSW) environment. Information collected by the MRUV would allow safer and more efficient utilization of SEAL/EOD divers in follow-on reconnaissance and clearance operations.

Phase I demonstrated enabling technologies in vehicle control, sonar and lidar sensors and is completing a concept design for modifying the EMATT into a small, low cost, clandestine MRUV. The Phase I effort was jointly funded by the Director of Expeditionary Warfare (N85) (\$ 245 K in FY 93) and the EOD/LIC Program Office (\$ 850 K in FY 94/95). ThermoTrex is the Phase I prime contractor with Sippican and Sonatech as principle subcontractors for the vehicle and sonar subsystems.

The proposed 5 inch diameter x 60 inch long MRUV has a dry weight of ~38 lbs. It is smaller, lower cost but has less endurance than larger submarine launched UUVs such as the Near Term Mine Reconnaissance System (NTMRS). However, its ability to operate in 8 ft. water depths would allow it to augment the NTMRS reconnaissance capability which is limited to water depths no shallower than 20 to 25 feet.

The MRUV is derived from the MK 39 Expendible Mobile ASW Training Target (EMATT), a 36 inch long x 5 inch diameter, air, surface or submarine delivered vehicle which can run at 8 knots for three hours. The EMATT has been in production for 4 years at 1,500+ units per year and a unit cost of about \$ 7 K.

A MRUV system design objective is to meet reconnaissance mission requirements while maximizing the use of EMATT subsystems to reduce development and production costs. To accomplish this the MRUV uses EMATT guidance, control, propulsion and hull subsystems. A 44 inch long nose and midbody containing an 8 lb. sonar soundhead, 5 lb. range-gated lidar, the EMATT G&C electronics, 3 lb. of sensor signal conditioning, recording and communication electronics, 8 lb. of rechargeable Li-Ion batteries and a 5 nautical mile fiberoptic cable are added to a 16" long EMATT motor and tail sections.

The MRUV control console uses a sonar processor and display identical to that employed for the MK 8 SDV Obstacle Avoidance Sonar.

The MRUV is launched at a 40 foot depth and proceeds to the beach on a programmed course. During this initial part of the reconnaissance mission, water depth, wave height, bottom roughness, density of mine-like sonar targets and visibility are measured and transmitted to a control console on a SDV over a fiberoptic data link.

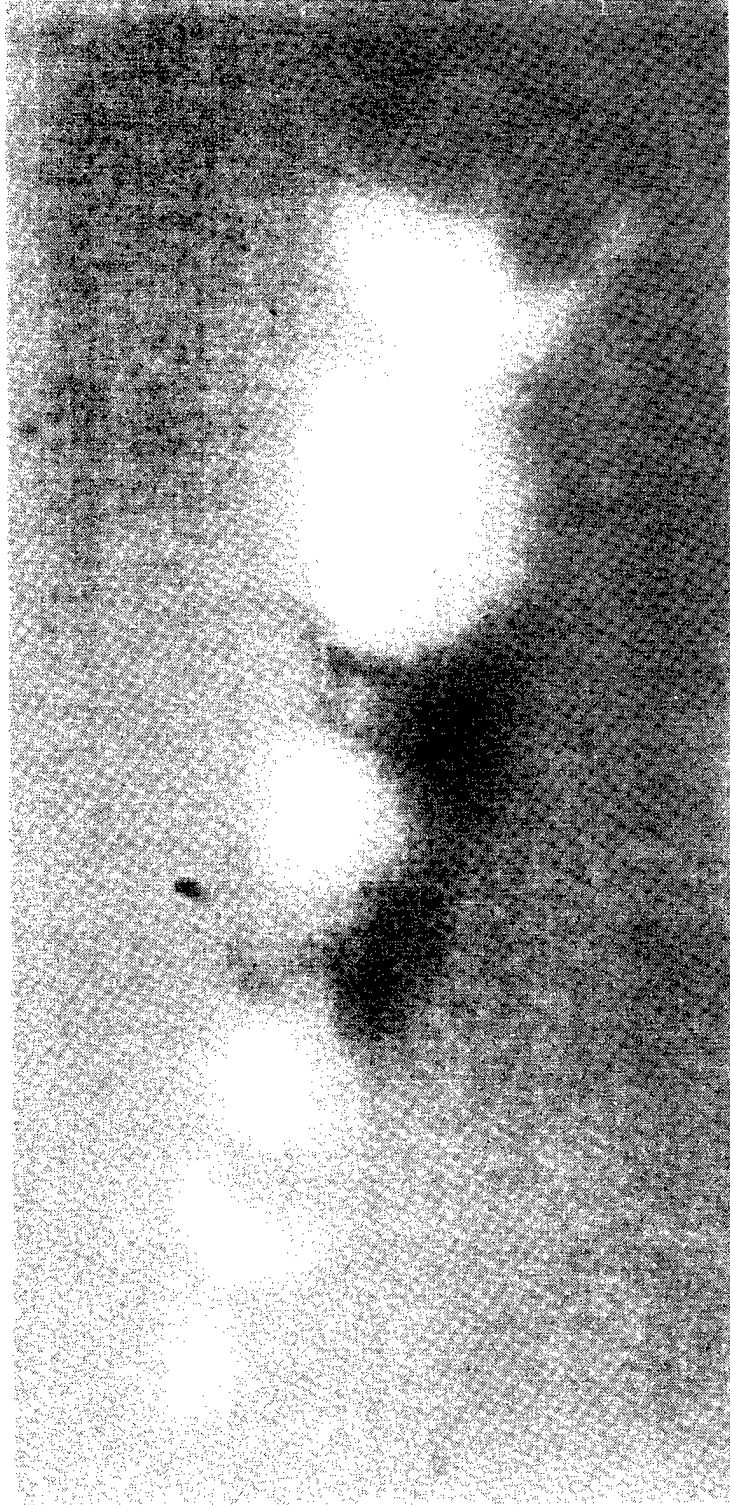
The remote operator analyzes data on the MRUV console and turns the vehicle parallel to the beach at the 10 foot curve. Lane spacing is optimized based upon sonar target density, bottom roughness, sonar target density and water column depth measured during the transit from the launch point to 10 foot depth. When operating over a smooth sand bottom, sonar detection range is about 100 yards allowing a lane spacing of 80 yards to be used to achieve 100% sonar overlap between lanes. The operator controls the MRUV to approach mine-like sonar targets and classify them with a range-gated lidar.

The MRUV Phase I effort has demonstrated that a small vehicle can effectively control itself and serve as a platform for small, low cost sonar and lidar mine detection and classification sensors - reducing development risk for an MRUV prototype.

# **Viewgraphs for Hendrickson Paper**



# Mine Reconnaissance Underwater Vehicle (MRUV) Preliminary Sea Test Results and Sonar Transducer Prototype



00461-95

## Office of Special Technology

Presented by:  
**ThermoTrex Corporation** – San Diego, CA  
**Sippican Inc.** – Marion, MA  
**SonaTech** – Santa Barbara, CA

<b>Team Member</b>	<b>Responsibility</b>
Office of Special Technology	Program Manager/Technical Oversight
ThermoTrex Corporation (TTC)	Prime Contractor System Engineering Data Recording and Analysis Position Sensing, Lidar and Image Processing
Sippican	Vehicle Development, Guidance & Control System, Communication Data Link
Sonatech	Minehunting and Obstacle Avoidance Sonar (MOAS) and Sonar Altimeter
Hendrickson & Associates	System Engineering & Mission Analysis

**MRUV SOLUTION TO ASSAULT LANE RECONNAISSANCE  
MINE RECONNAISSANCE UNDERWATER VEHICLE (MRUV)**

**OFFICE OF SPECIAL  
TECHNOLOGY**

- Small, remotely operated, clandestine reconnaissance platform to augment SEAL/EOD diver and MK 8 SDV reconnaissance capability
- Conduct mine reconnaissance within the 40' to 10' depth region more rapidly, with higher probability of mine detection (and classification) and less risk
- Free up SEAL/EOD personnel and delivery vehicles for other missions
- Collateral Mission - Measure environmental parameters needed for optimizing performance of airborne, submersible, and surface ship minehunting sonars; airborne and submersible LIDAR; and influence mine sweeping systems
- MRUV area search rate (100% sonar overlap)  $\approx$  0.18 sq. nm/hour for 1.5 hours
  - a 500 yard wide x 2,000 yard long amphibious assault lane
  - 8 x the area search rate of a pair of SEAL or EOD divers
  - MRUV searches shallowest part of the VSW part of the amphibious assault lanes while SDV searches the deeper areas (> 25" depth)

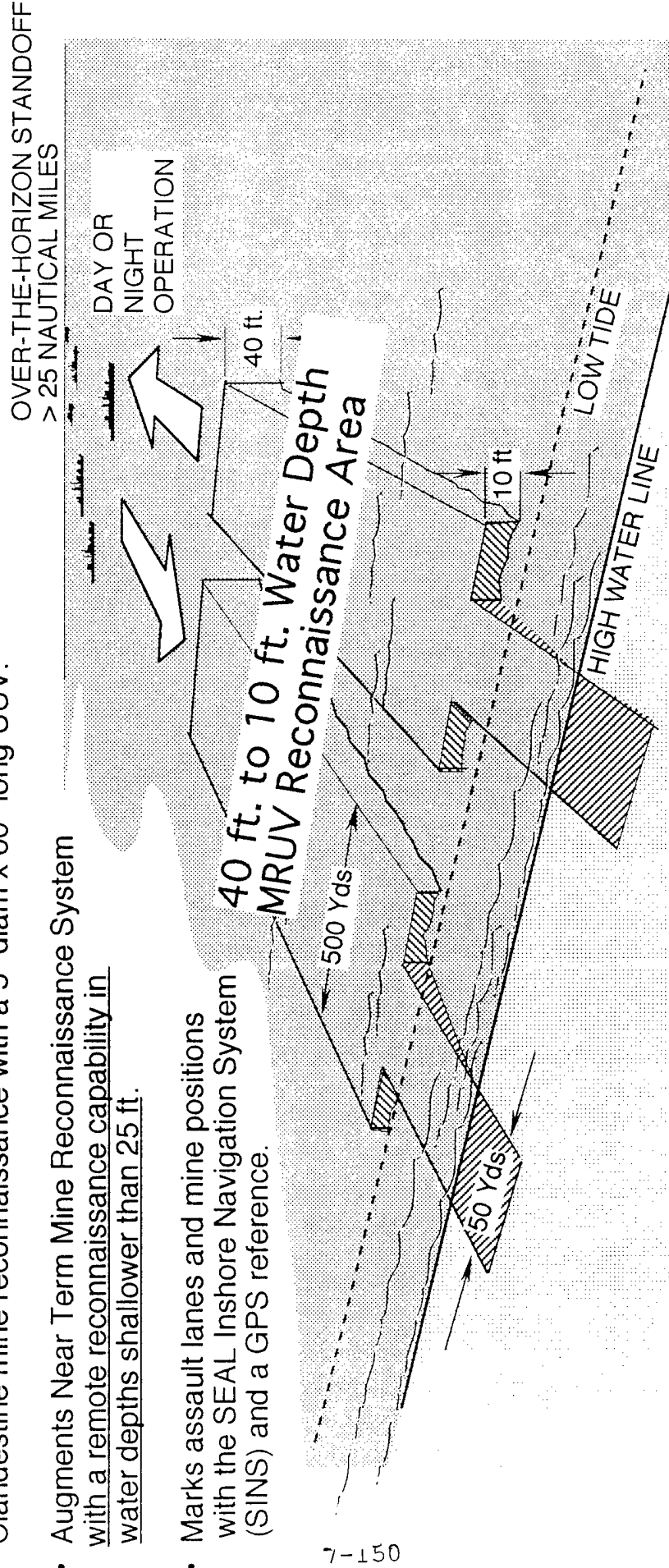
# CLANDESTINE MINE RECONNAISSANCE VEHICLE IN VERY SHALLOW WATER (40 ft. to 10 ft.)

ThermoTrex  
Sippican  
SonaTech

OFFICE OF SPECIAL  
TECHNOLOGY

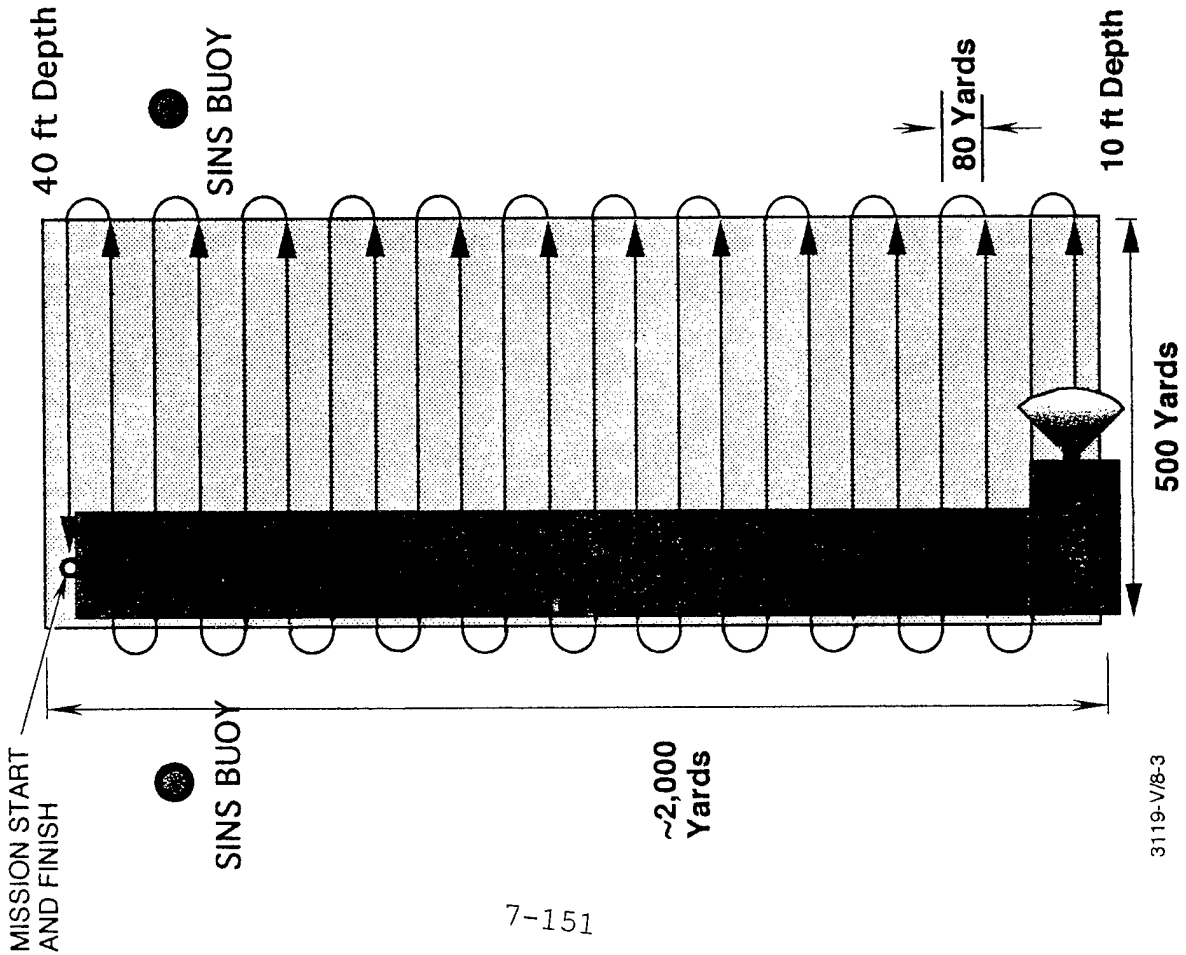
## Mine Reconnaissance Underwater Vehicle (MRUV) in Amphibious Advanced Force Operations

- Clandestine mine reconnaissance with a 5" diam x 60" long UUV.
- Augments Near Term Mine Reconnaissance System with a remote reconnaissance capability in water depths shallower than 25 ft.
- Marks assault lanes and mine positions with the SEAL Inshore Navigation System (SINS) and a GPS reference.



TTC/SIPPICAN/S ONA TECH PROPRIETARY /  
Use or disclosure of data contained on this sheet  
is subject to the restriction on page ii.

# MRUV ASSAULT LANE RECONNAISSANCE



## RECONNAISSANCE MISSION PROFILE

Survey 2,000 yard long x 500 yard wide amphibious assault lane in 90 minutes.

MRUV controlled by remote operator in SDV or surface craft via fiberoptic cable.

MRUV speed - 5 knots.

1st search lane perpendicular to beach to measure water depth and density of mine-like sonar targets.

24 search lanes parallel to beach. Lane spacing - 80 yards.

MRUV automatically follows search pattern. Remote operator intervention used only to:

- Change search pattern
- Avoid Obstacles
- Approach mine-like targets.

Sonar range 125 yards. Single ping detection range against 1 foot diameter (-20 dB) mine target on bottom.

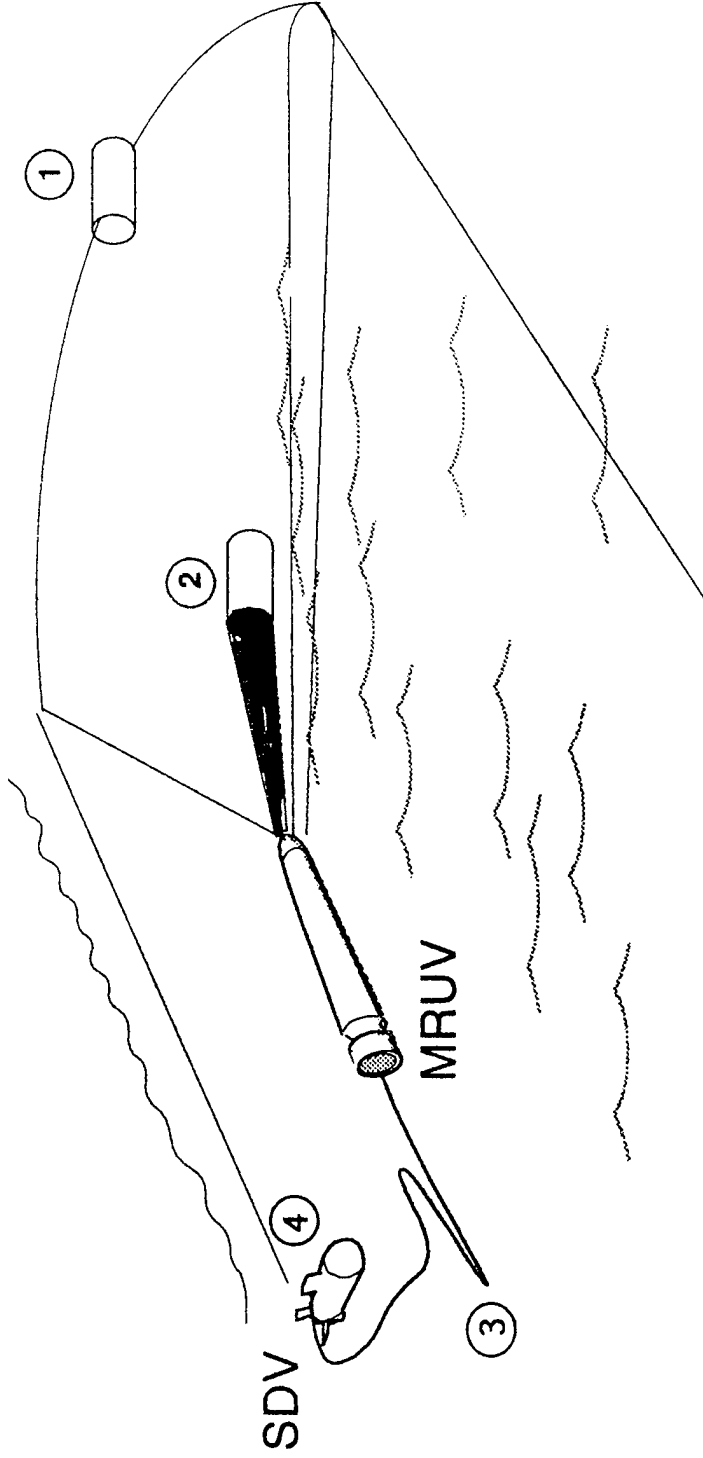
Sonar search swath ~175 yards. More than 100% overlap between adjacent lanes.

Range gated lidar used for identification of sonar targets at ranges of ~ 10 yards.



# MRUV - TARGET ENCOUNTER

---

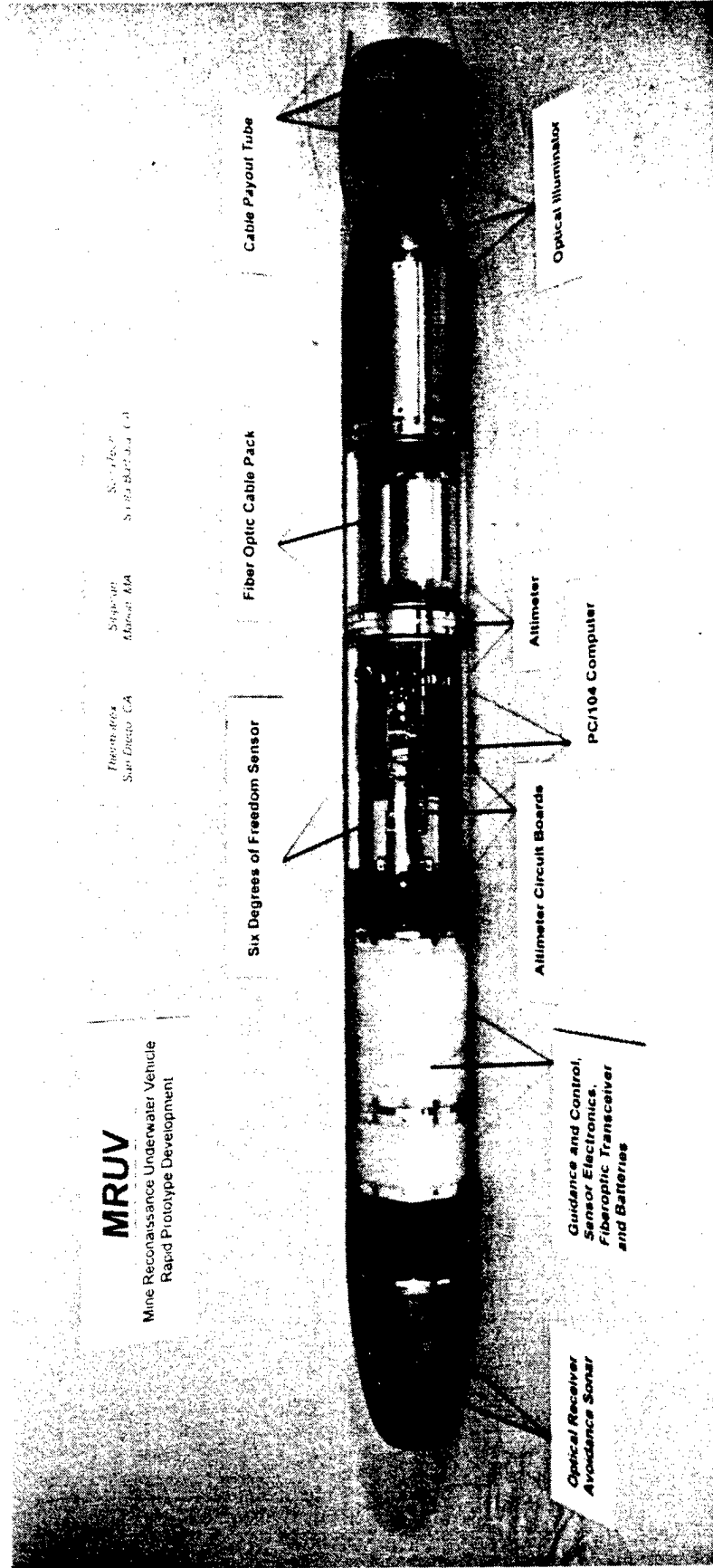


- (1) Detect and track mine target with SONAR (100 to 125 yards).
- (2) Classify mine with range gated LIDAR (10 to 20 yards).
- (3) Uplink SONAR/LIDAR data over fiberoptic cable
- (4) Process, Display & Record SONAR and LIDAR images on SDV

## **ADVANTAGES OF MRUV APPROACH**

- Rapid detection and classification of mine like objects
- Target search and acquisition performed with SONAR,
  - Long range but low resolution
- Mine-like SONAR targets imaged with LIDAR
  - High resolution imaging
  - Low LIDAR duty cycle lowers power consumption and data rates
  - Intermittent LIDAR operation provides low probability of intercept
- Search, track, image, and classify can be automated if desired

# MINE RECONNAISSANCE UNDERWATER VEHICLE



- 57 in. length
- 35 lb. displacement
- Payload 22 lb.
- 4 7/8 in. diameter
- Speed: 4-5 kts
- Range: 6 nautical miles
- Battery = 5.5 lb. rechargeable

**MRUV COMPONENT FUNCTIONS**

Vehicle - Provide stable platform for SONAR and LIDAR  
semi-autonomous operation

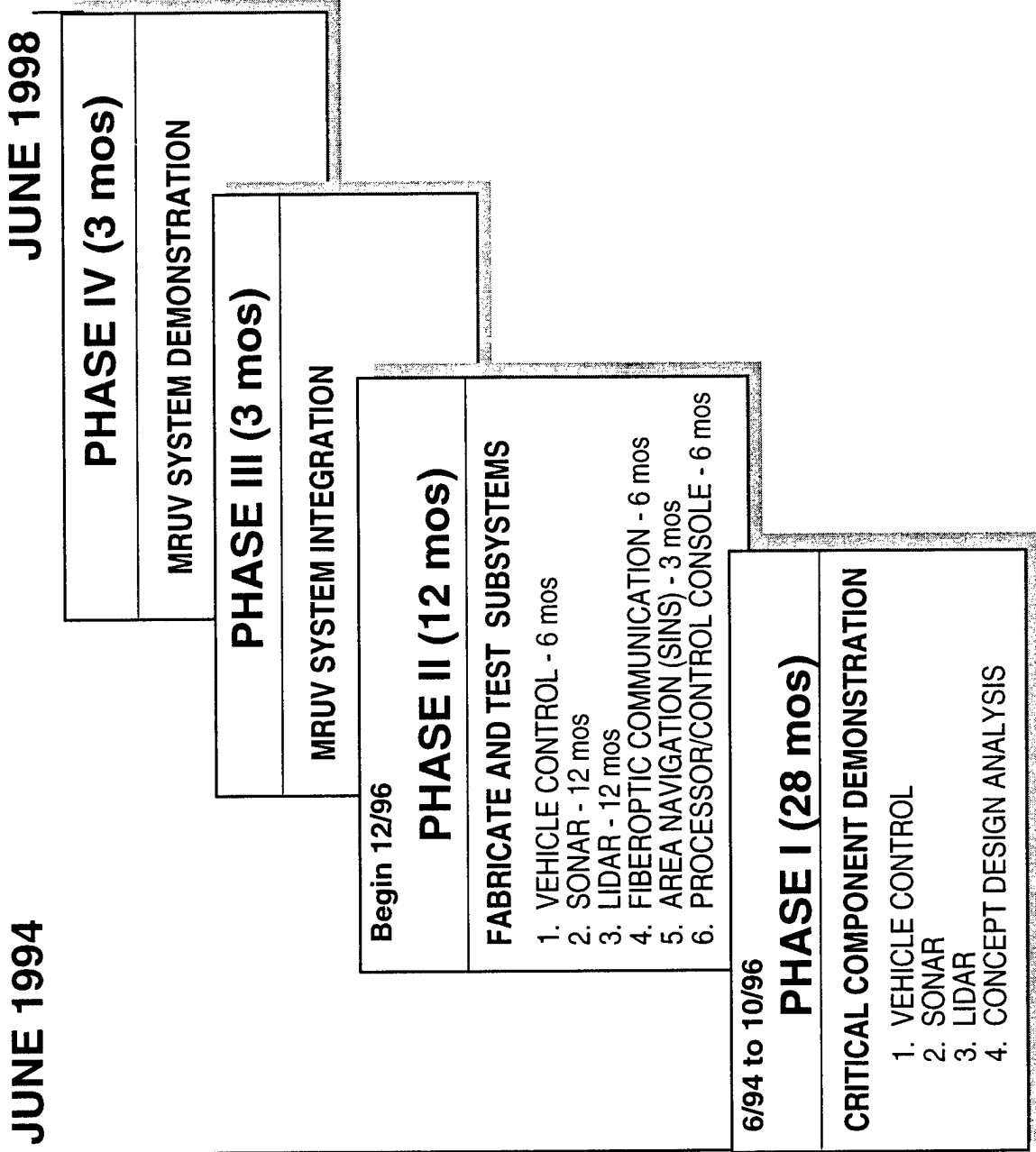
SONAR - Detect mine-like objects

LIDAR - Image mine-like objects to classify

Data Link - Pass SONAR & LIDAR information to command and  
control vehicle

Processor - Integrate SONAR & LIDAR data and provide user  
interface and control (as required)

# MRUV TECHNOLOGY ROADMAP



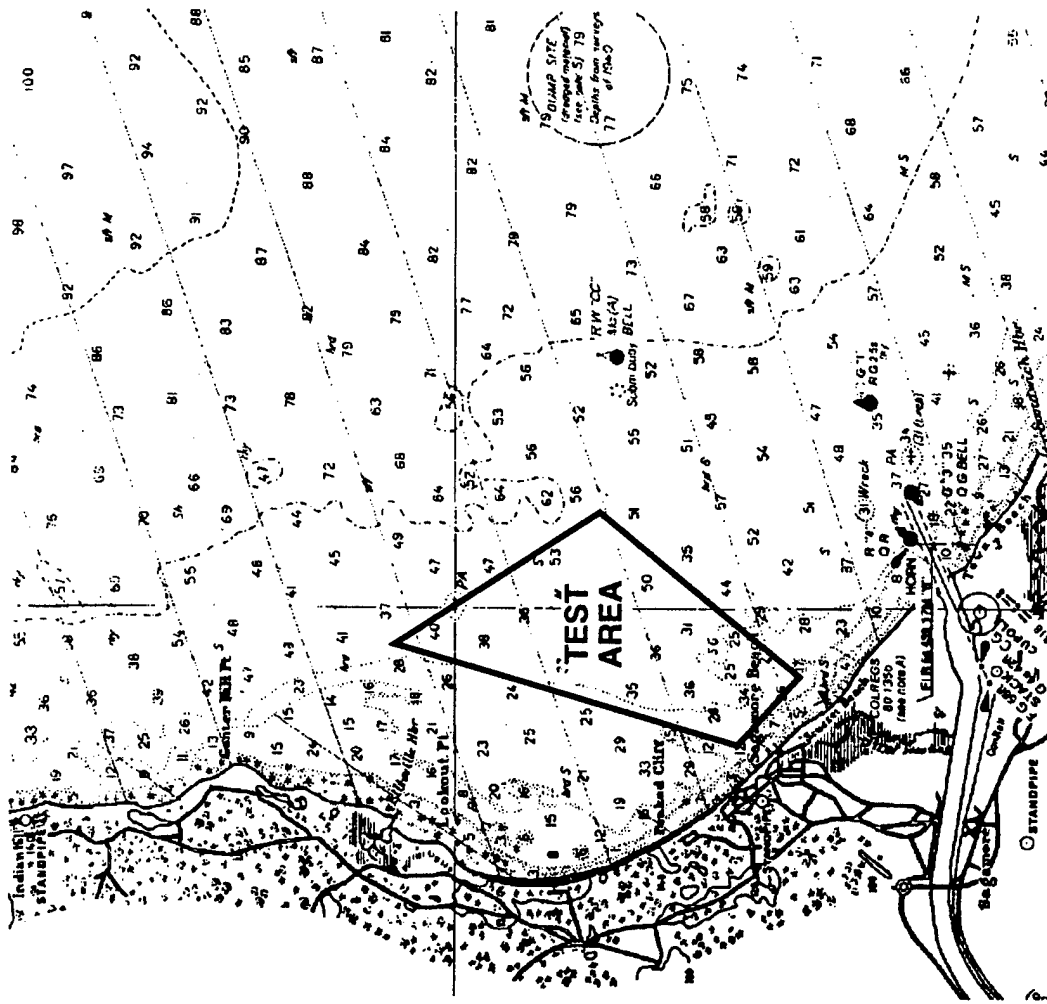
## **MRUV VEHICLE STABILITY AND CONTROL GOALS**

- Driven by requirement for stable performance in VSW environment (10'-40' depth) for SONAR/LIDAR
- Depth control to  $\pm 2'$
- Pitch angles less than  $5^\circ$
- Roll angles less than  $5^\circ$
- 5 knt speed
- Blunt nose to maximize SONAR/LIDAR apertures

**MRUV Sea Test Results**

# MRUV SEA TRIALS IN CAPE COD BAY

OFFICE OF SPECIAL  
TECHNOLOGY



- Cape Cod Bay VSW test site near Sippican
- Speeds 3, 4 and 5 kts
- Water depths 40 ft., 20 ft., 10 ft.
- Sea states 0-1



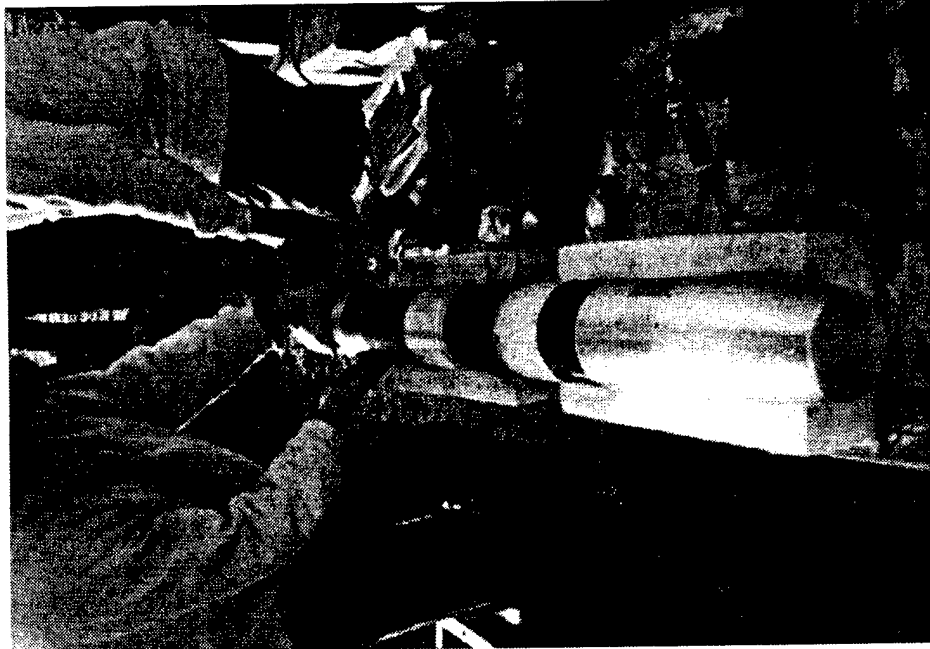
## MRUV AFTER SUCCESSFUL TEST RUN

OFFICE OF SPECIAL  
TECHNOLOGY

**Cape Cod Bay**  
**February 1995**  
38 Test Runs  
Depth control  $\pm 2$  ft.  
10 ft. - 40 ft. water depths

**June 1996**  
11 Test Runs  
Improved depth control  $\pm 1$  ft.

**August 1996**  
16 Test Runs  
Bottom following with altimeter - 3 ft.  
Mid-water depth control  $\pm 1$  ft.



95-19399a

# MRUV CONTROL IN VERY SHALLOW WATER

---

MRUV should be sufficiently stable at a speed of 5 Knots for effective use of sonar and lidar sensors in Sea State 1.5 to 2.

	REQUIREMENT	SEA TEST RESULTS
Depth Control	± 2 ft	± 1 ft
Altitude above Bottom (Bottom following mode)	± 2 ft	± 0.5 ft at 3 ft Altitude
Pitch	± 5°	± 3°
Heading	± 3°	± 3°
Turn Rate	5°/second	8°/second

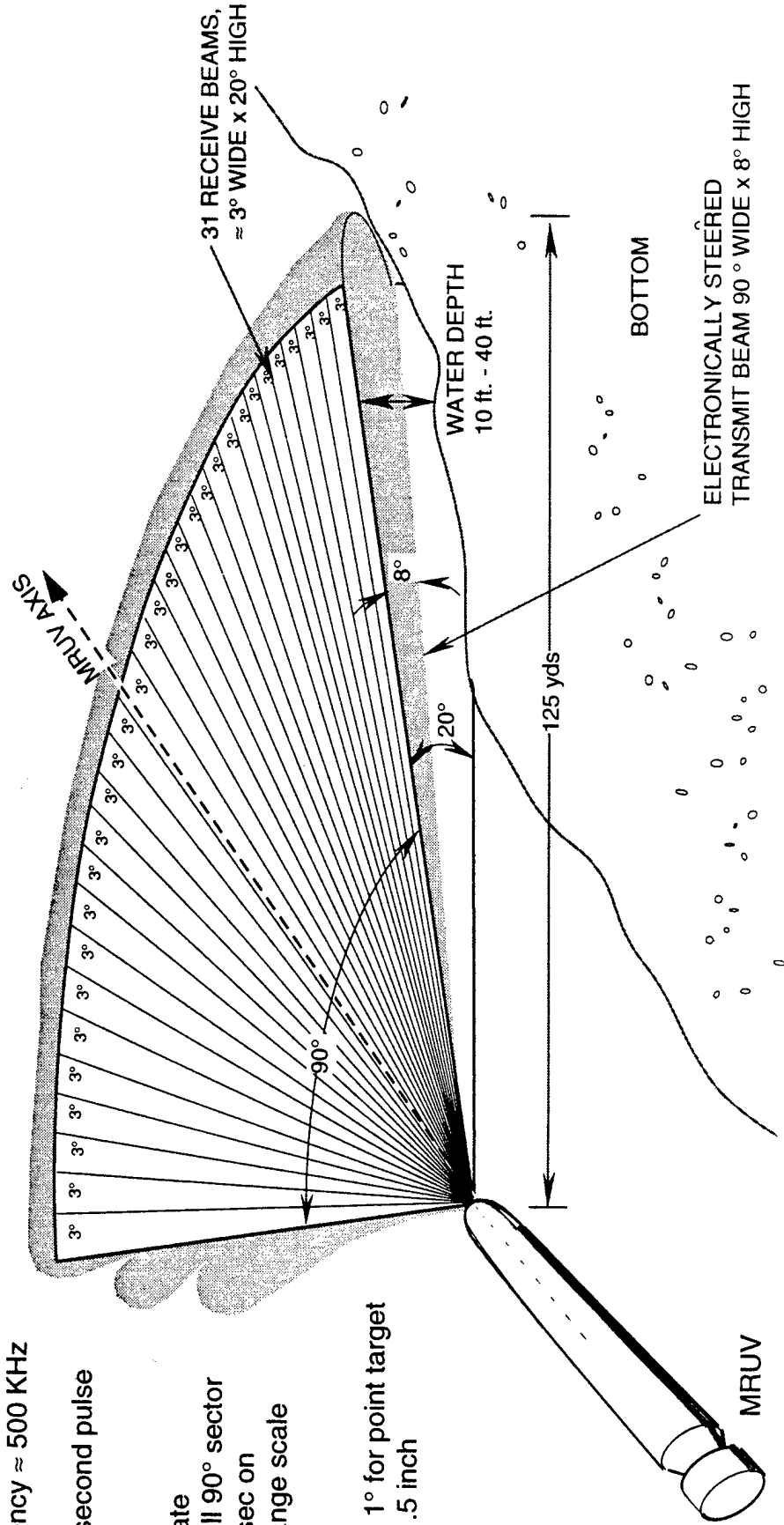
# **MRUV Sonar Transducer Prototype Results**

# ELECTRONICALLY SCANNED MINE-HUNTING AND OBSTACLE AVOIDANCE SONAR (MOAS)

ThermoTrex  
Sippican  
SonaTech

## OFFICE OF SPECIAL TECHNOLOGY

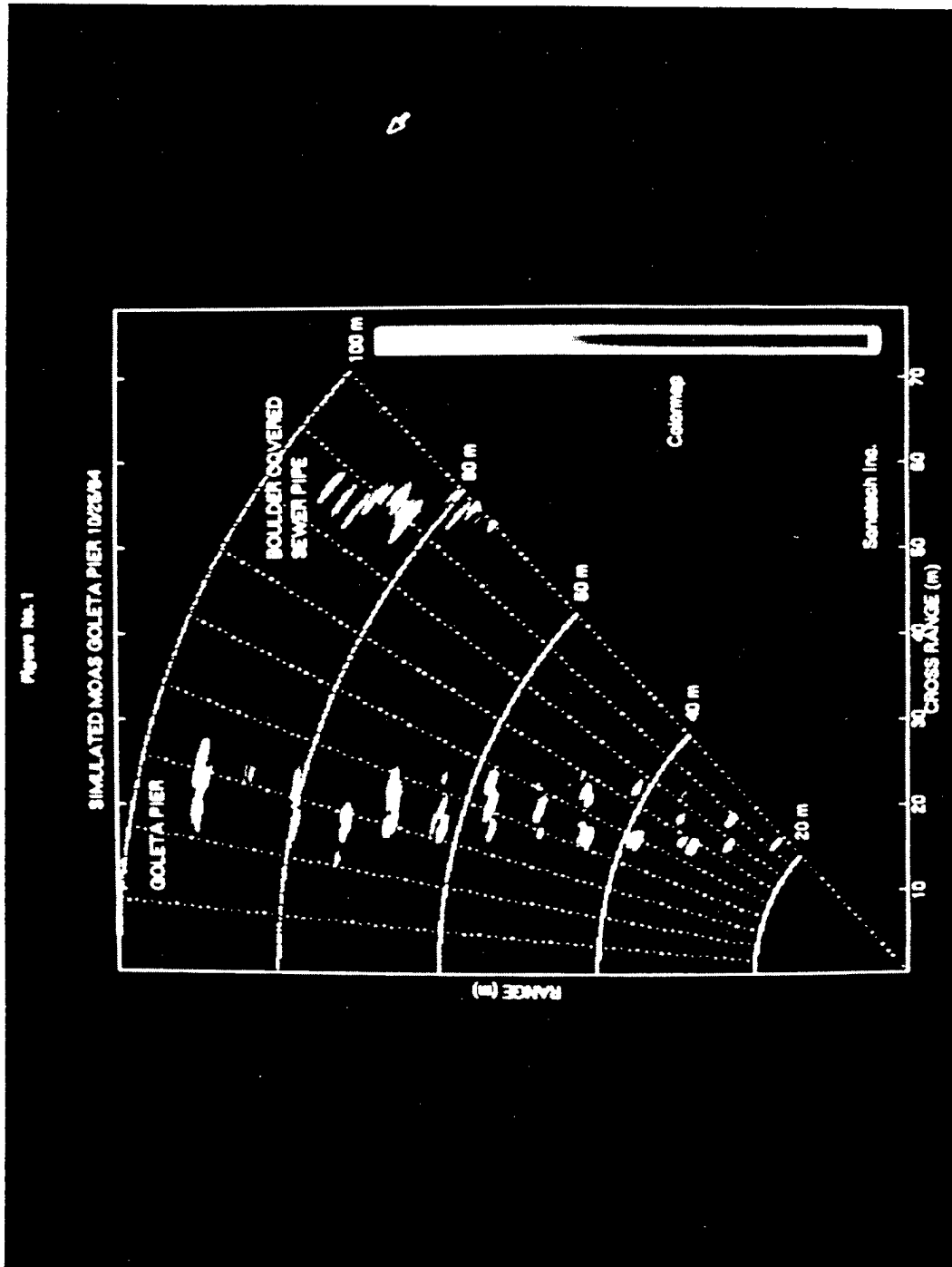
- Short range  $\approx$  75 yds - 150 yds
- High frequency  $\approx$  500 KHz
- 100 microsecond pulse length
- High data rate
  - Scans full 90° sector 6 times/sec on 125 m range scale
- Resolution
  - Azimuth  $\approx$  1° for point target
  - Range  $\approx$  1.5 inch



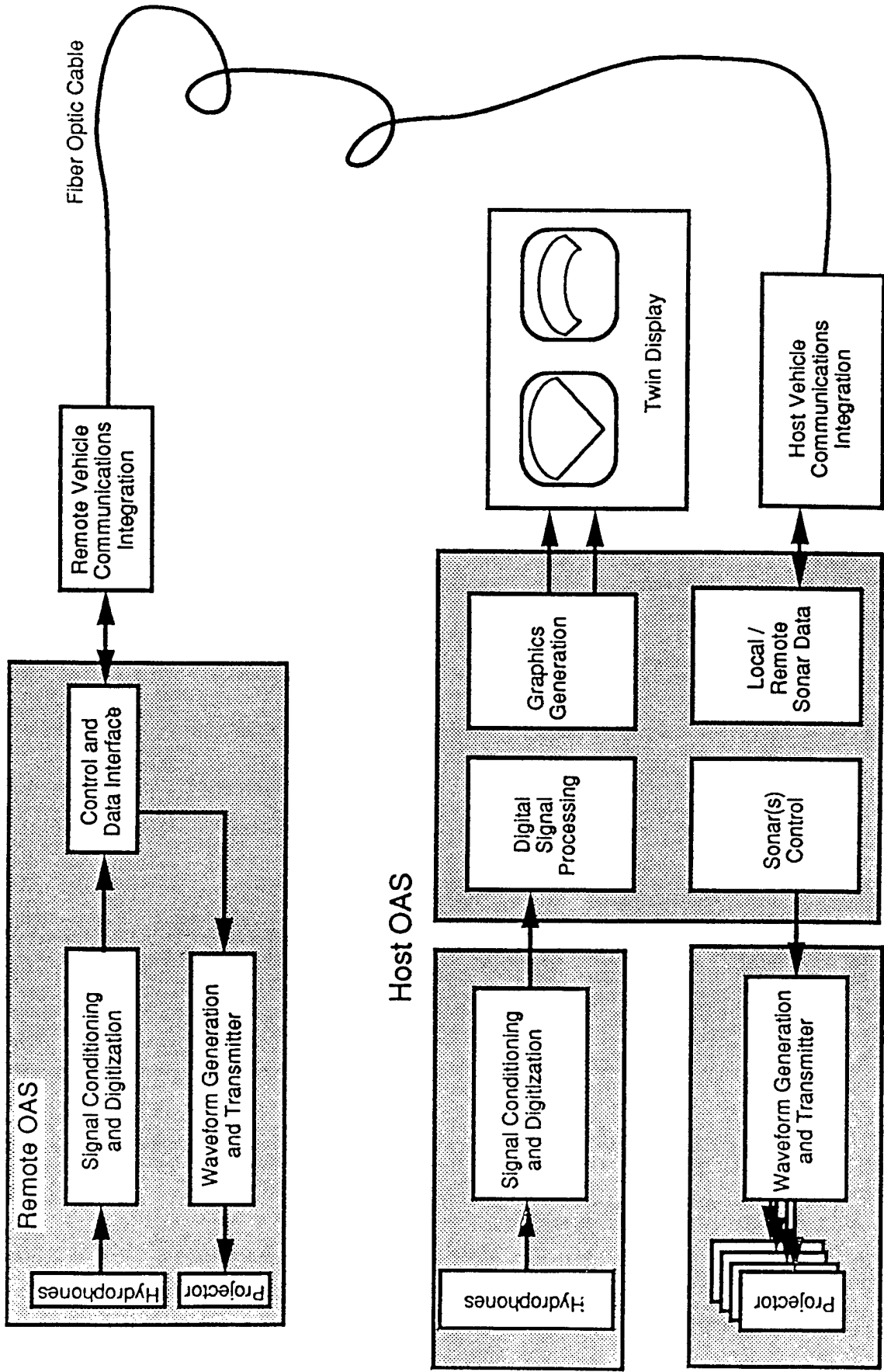
## MRUV SONAR GOALS

- Driven by detection range in VSW environment
  - for -20 dB target on Type 2 (sand) bottom in 10' of water
- Max range = 75 yds (expect to get 125 yds)
- Range resolution = 3"
- Field of view (Horiz)  $\pm 45^\circ$
- Vertical Beamwidth projector =  $8^\circ$   
receiver =  $20^\circ$
- Horizontal Beamwidth projector =  $90^\circ$   
receiver =  $3^\circ$

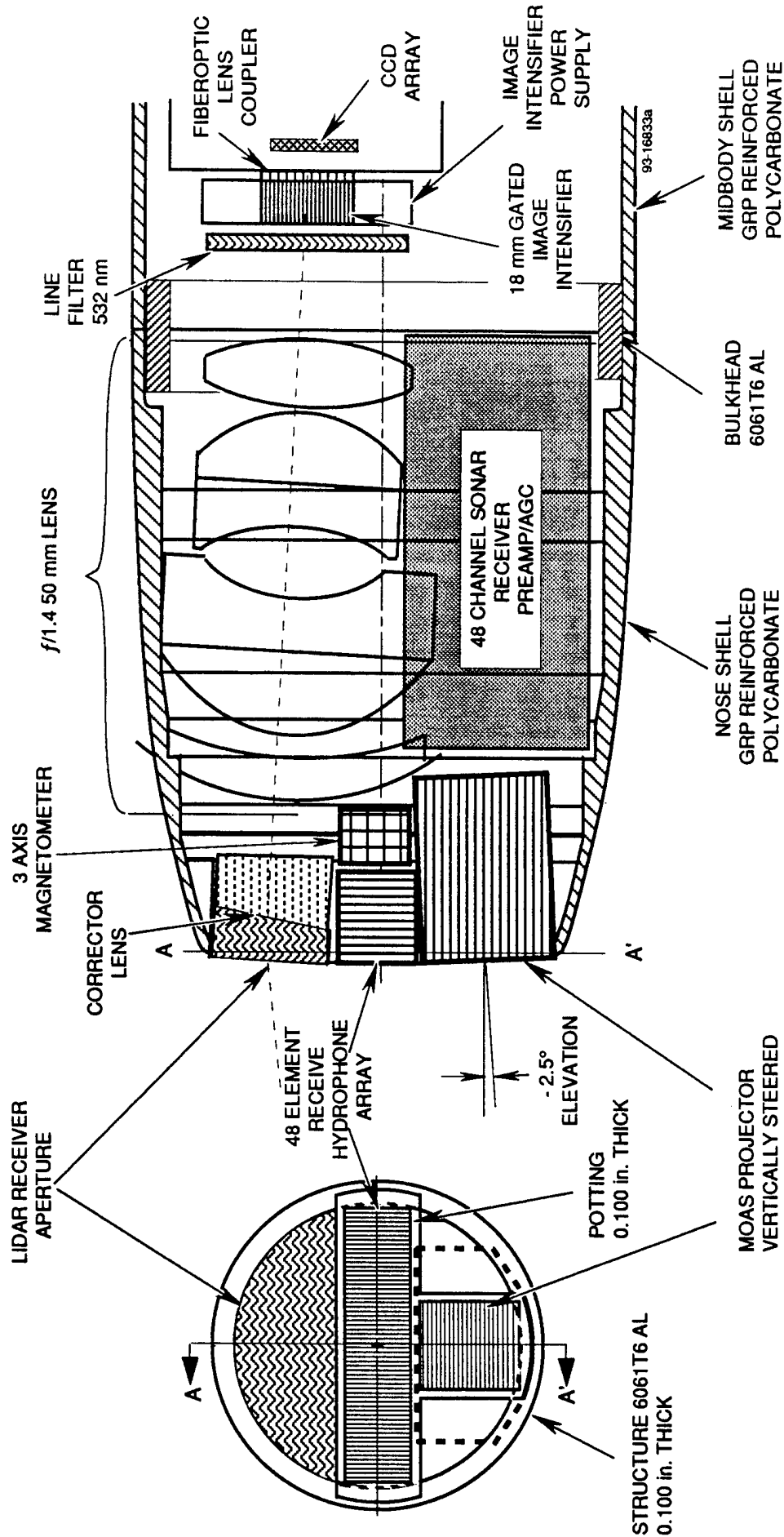
# SIMULATED PERFORMANCE OF MINEHUNTING AND OBSTACLE AVOIDANCE SONAR



# FINAL MOAS CONFIGURATION

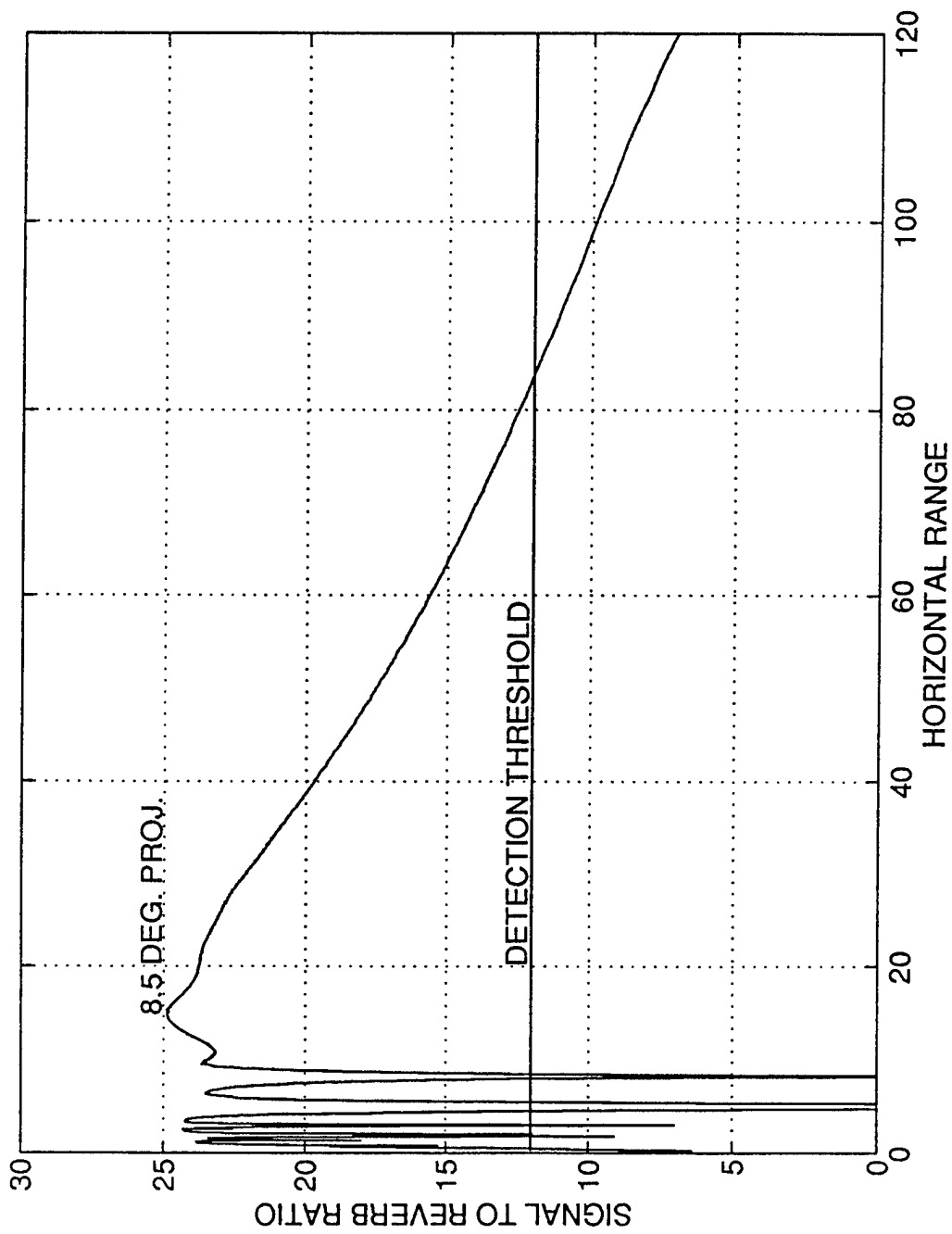


# MRUV NOSE WITH 3-AXIS MAGNETOMETER, MINEHUNTING SONAR AND LIDAR RECEIVER INSTALLED

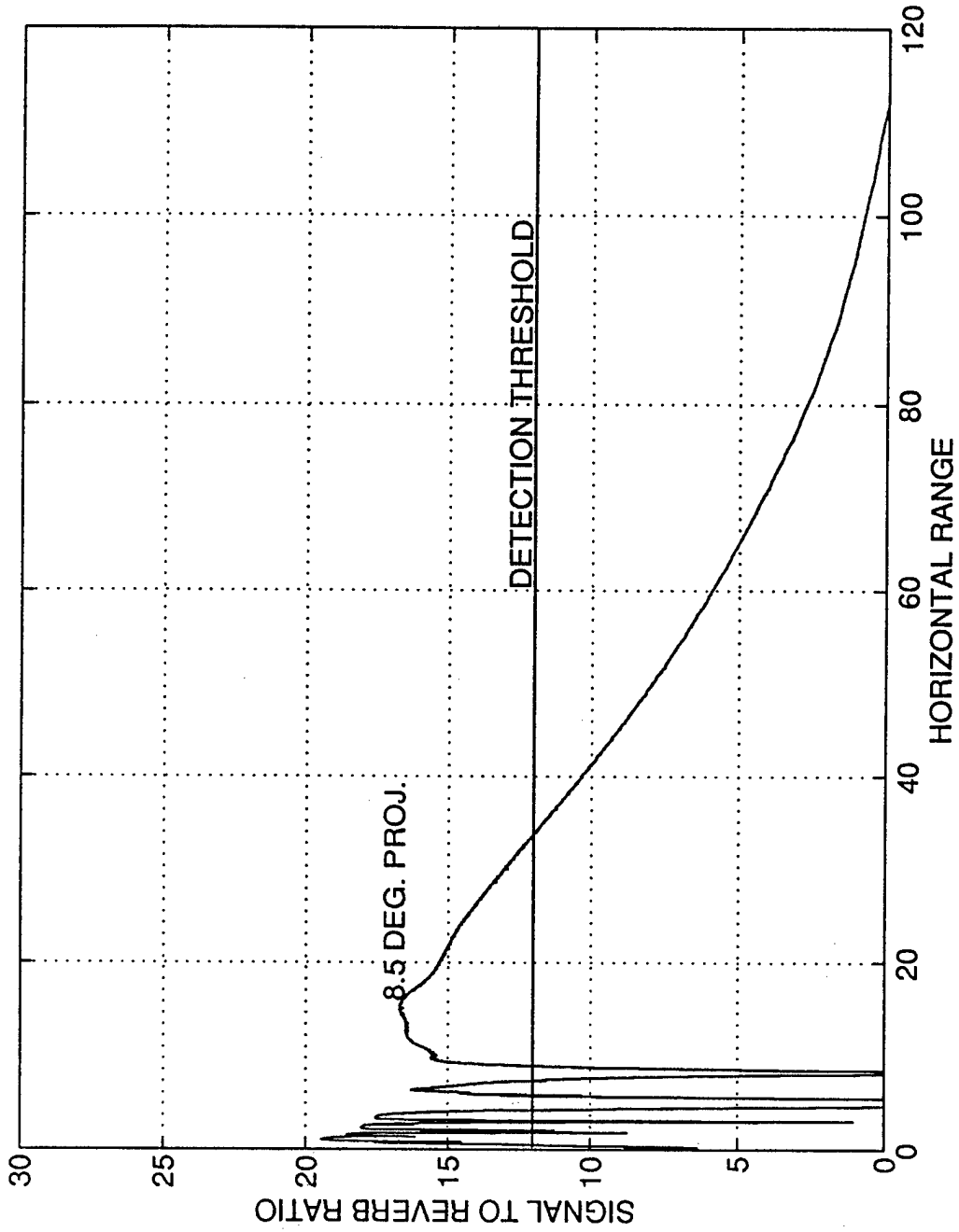




# MOAS PERFORMANCE SAND BOTTOM



# MOAS PERFORMANCE GRAVEL BOTTOM



# PHASE I SONAR RESULTS

---

Developed and tested projector and part of hydrophone array.

Projector - 1.75" diameter x 1.25 " high.

Hydrohone Array - 48 elements, 3.5" wide x 1.0 " high

Test Results - 20 dB mine target, sand bottom  
water depth - 10 feet 100 feet  
predicted range - 91 yds 115 yds

Soundhead Weight - 8.5 lb.

Soundhead Power - < 70 watts

# PROGRAM PLAN PHASE II

---



BUILD A PROTOTYPE MOAS, FORM AND FIT COMPLIANT,  
WHICH MEETS ALL PERFORMANCE PARAMETERS EXCEPT  
IMAGE UPDATE RATE.

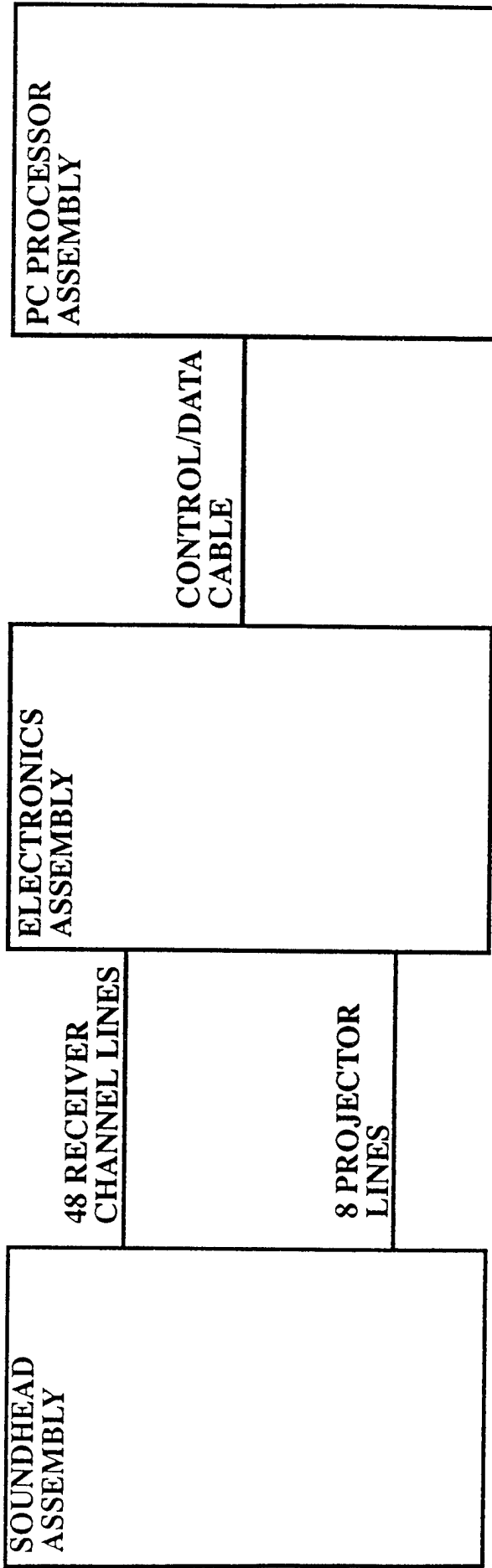
## REQUIREMENTS

90° HORIZONTAL FOV  
2.7° - 3.7° HORIZ BEAM WIDTH  
15° VERTICAL FOV  
8° VERTICAL BEAM WIDTH  
75M + OPERATING RANGE  
IMAGE UPDATE RATE 8 HZ  
24 KM FIBER OPTIC TETHER

## PHASE II DELIVERABLE ITEM

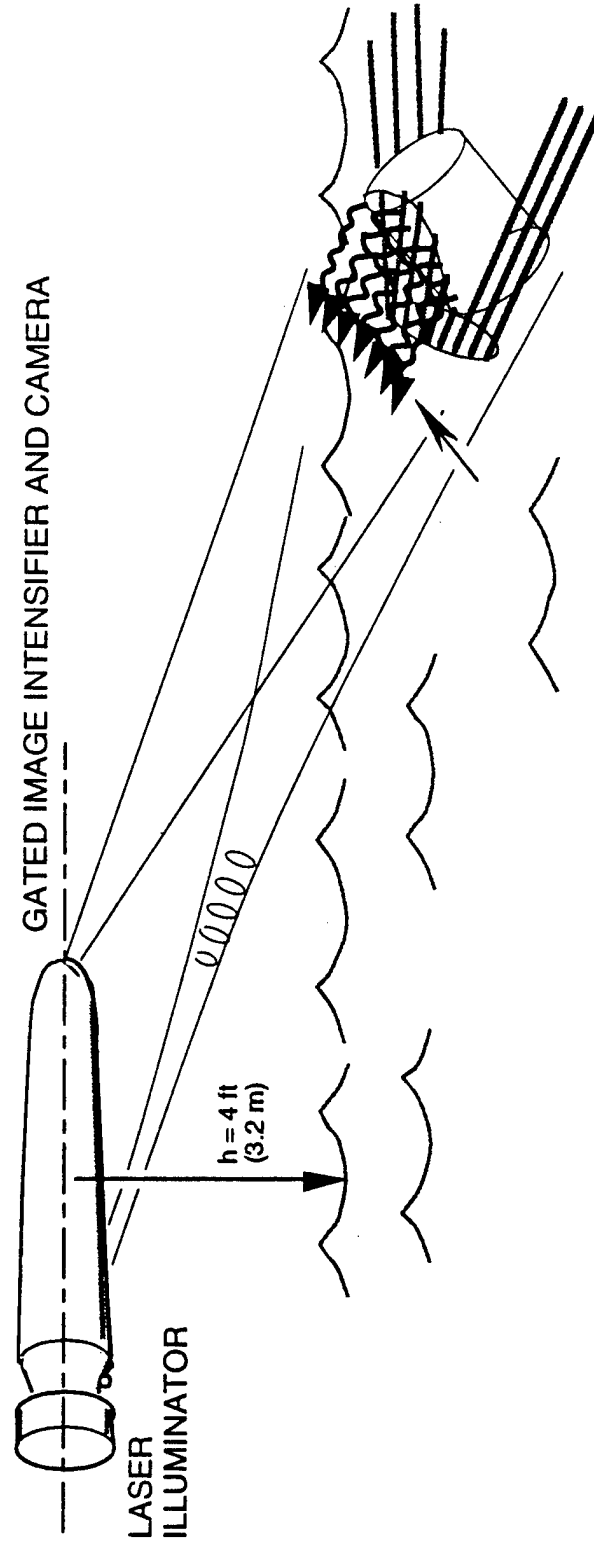
90° HORIZONTAL FOV  
2.7° - 3.7° HORIZ BEAM WIDTH  
15° VERTICAL FOV  
8° VERTICAL BEAM WIDTH  
75M + OPERATING RANGE  
IMAGE UPDATE RATE 1/60 HZ  
100' MULTIPLE CONDUCTOR TETHER

# MOAS CONFIGURATION PHASE II



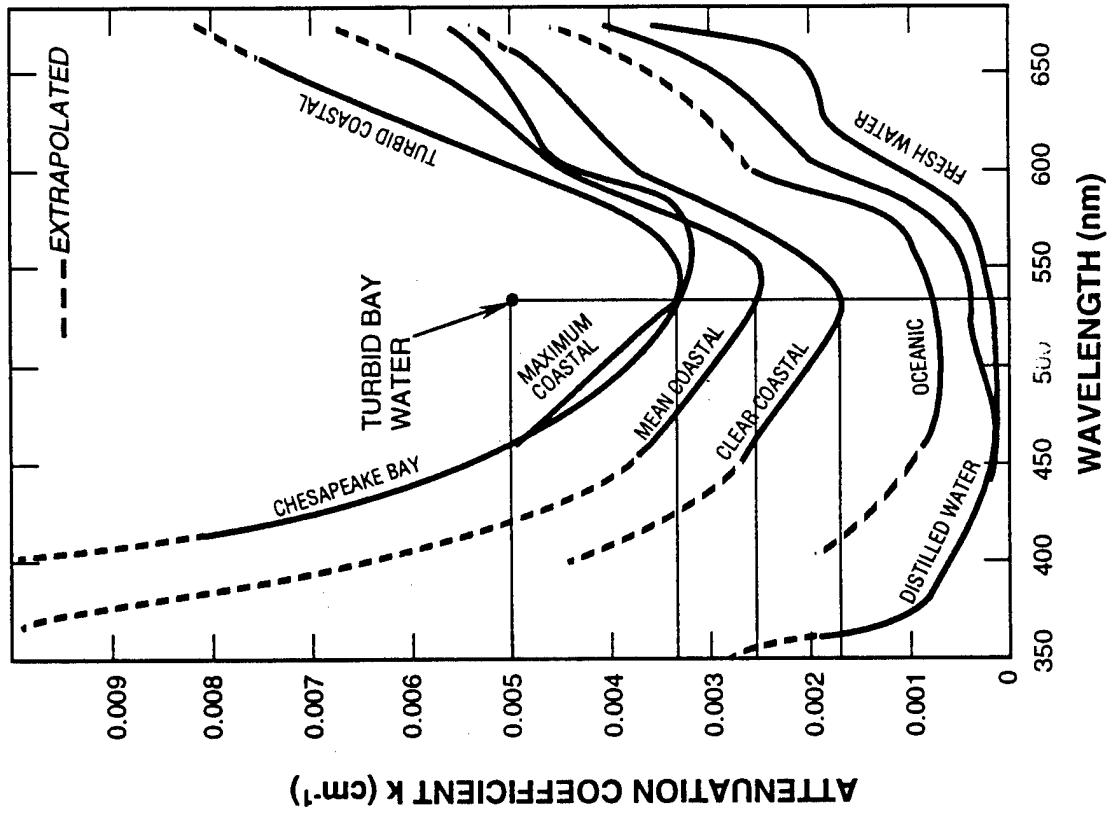
**RANGE-GATED LIDAR**

# RANGE GATED LIDAR



# ATTENUATION COEFFICIENT VS. WAVELENGTH FOR VARIOUS WATER CONDITIONS

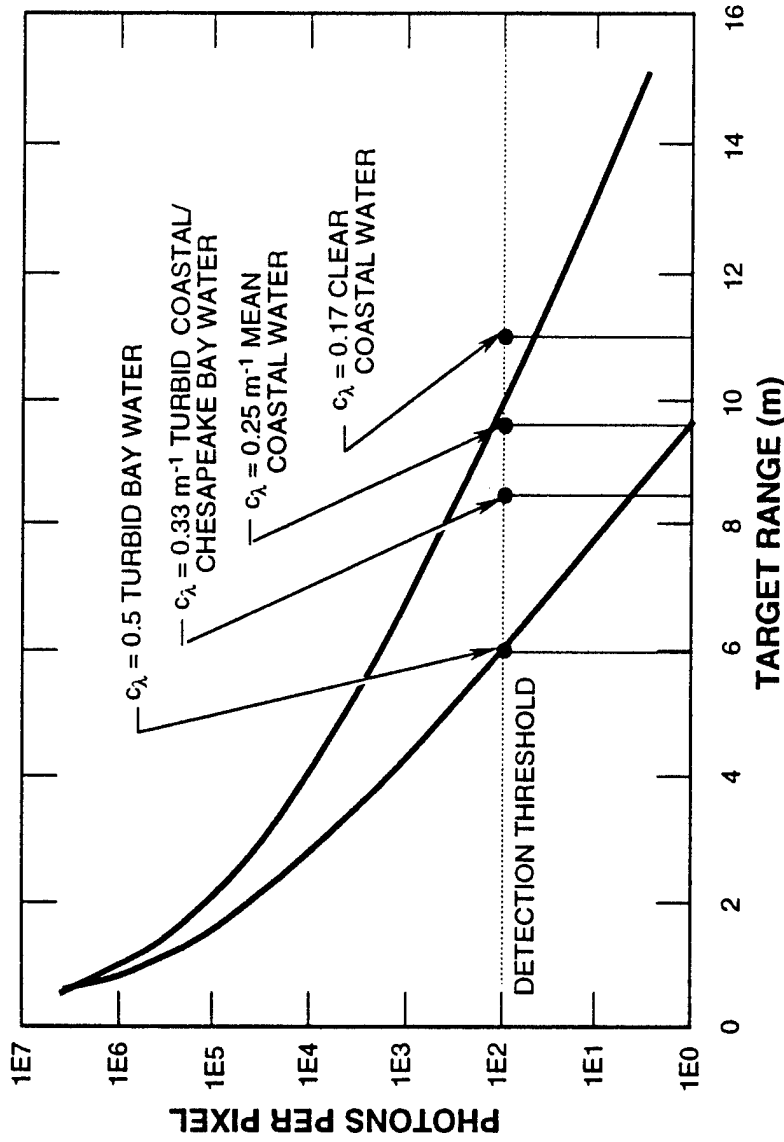
OFFICE OF SPECIAL  
TECHNOLOGY



TTC/SIPPICAN/SONATECH PROPRIETARY INFORMATION  
Use or disclosure of data contained on this sheet  
is subject to the restriction on page ii.



**OFFICE OF SPECIAL TECHNOLOGY** **SINGLE PULSE FLUENCE PROVIDES SUFFICIENT RETURN TO DETECT SMALL FEATURES ON A TARGET AT ~ 10 m** *ThermoTrex Sippican SonaTech*



- Gated image intensifier with ~10% quantum efficiency requires > 100 photons/pixel as a detection threshold
- Small features (~ 1.5 inch) on targets within ~ 10 m should be detectable in 0.25 m<sup>-1</sup> mean coastal water

TTC/SIPPICAN/SONATECH PROPRIETARY INFORMATION  
Use or disclosure of data contained on this sheet is subject to the restriction on page ii.

## LIDAR SUBSYSTEM RECOMMENDATIONS

---

Smooth, low contrast mine targets may be difficult to image but still provide reasonable edge definition if illuminated from a horizontal angle. Mines with discriminating shapes such as MANTA and tilt rod types may be successfully classified in this manner.

Use of a very short (~1 ns) laser pulse and receiver range-gate is best for small targets in turbid water. A longer 4ns pulse and range-gate interval may be suitable in less turbid water, particularly if edge detection is the classifying technique used.

- Los Alamos National Lab demonstrated such a system with Gen II Image Intensifier w/ MCP and a in house designed 2,200 V gating pulser with stripline to shorten pulse and match MCP impedance.
- Upgrade system using a high quantum efficiency Gen III extended blue image intensifier with MCP or PIXELVISION Gen IV Imager using Electron Bombarded Backlit CCD(EBCCD).
- Both configurations can use the same LANL pulser (also used in Hendrickson & Associates Diver Sonar-Lidar/Navigator SBIR).

Other Use of this technology:

- Range-gated Gen III MCP and EBCCD using different doping on photocathode can be operated at a 1560 nm eye safe wavelength for use in a wide variety of terrestrial operations

**MRUV CONCEPT DESIGN**

# MRUV CONCEPT DESIGN

---

## THREE MRUV CONFIGURATIONS ARE BEING INVESTIGATED:

### SHORT TERM (1-2 Yrs) - 36 in. long x 5 in. diam. UNTETHERED UUV -

Records water depth, wave height, conductivity, visibility & GPS position  
Air, surface or subsurface deliverable.  
Acoustic or RF data link  
Expendible  
~ 240 minute endurance at 5 knots

### NEAR TERM (3 Yrs) - 60 in. long x 5 in. diameter TETHERED UUV -

MOAS (Developmental sonar, 3° resolution, 70 watts)  
Range-gated LIDAR classification sensor  
12 km F/O data link  
90 minute endurance at 5 knots - Searches 0.25 square mile  
Life Cycle Cost/Mission - \$ 9.5 K

### MID TERM (3-4 Yrs) - 60 in. long x 5 in. diameter UNTETHERED UUV -

MOAS with autonomous obstacle avoidance & target tracking  
Range-gated LIDAR  
6-10 km acoustic data link  
> 150 minute endurance at 5 knots - Searches 0.4 square mile  
Life Cycle Cost/Mission - \$ 5-6 K

# MRUV CONCEPT DESIGN

Use EMATT Afterbody, Propulsion & Control Surfaces

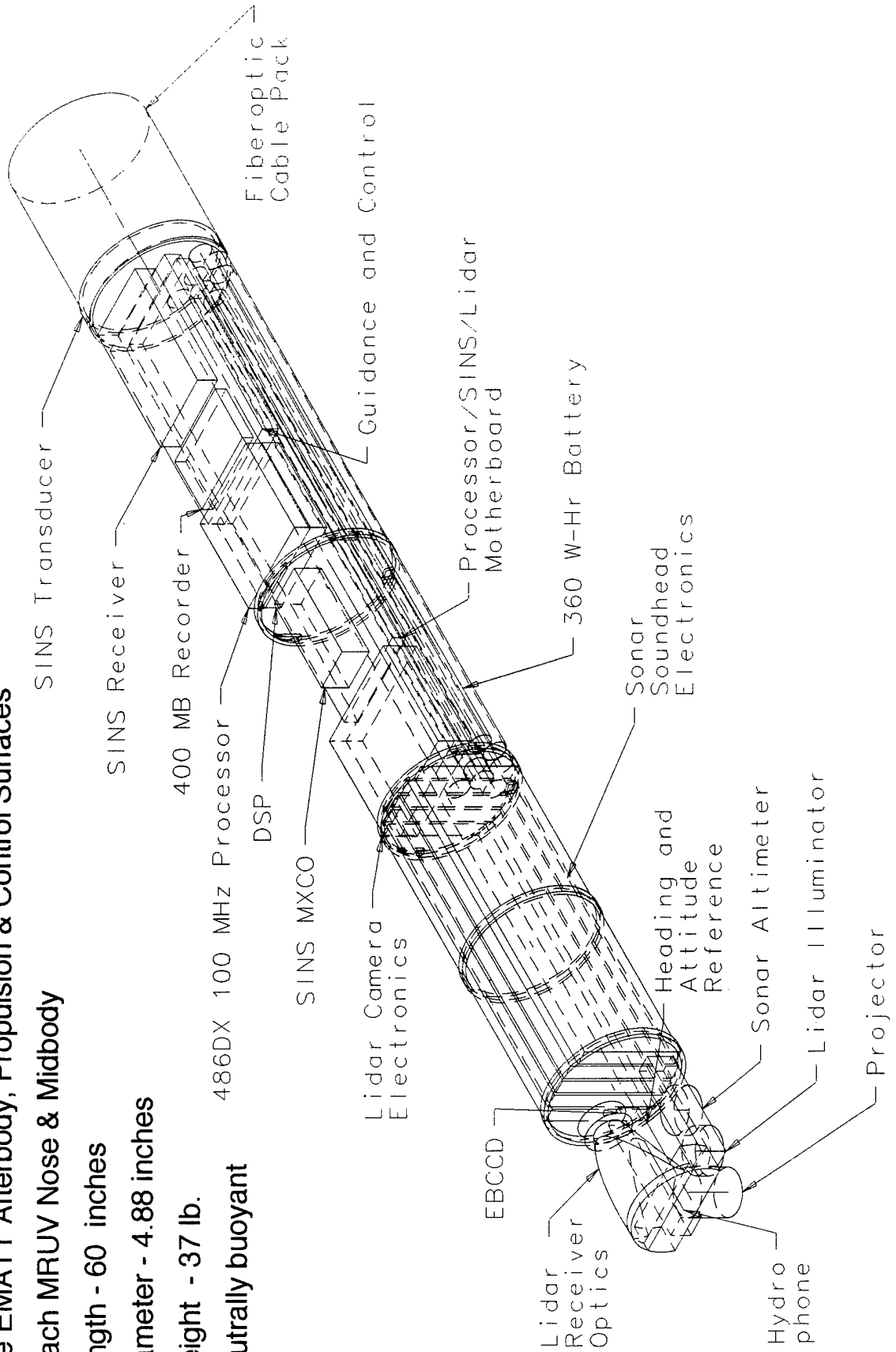
Attach MRUV Nose & Midbody

Length - 60 inches

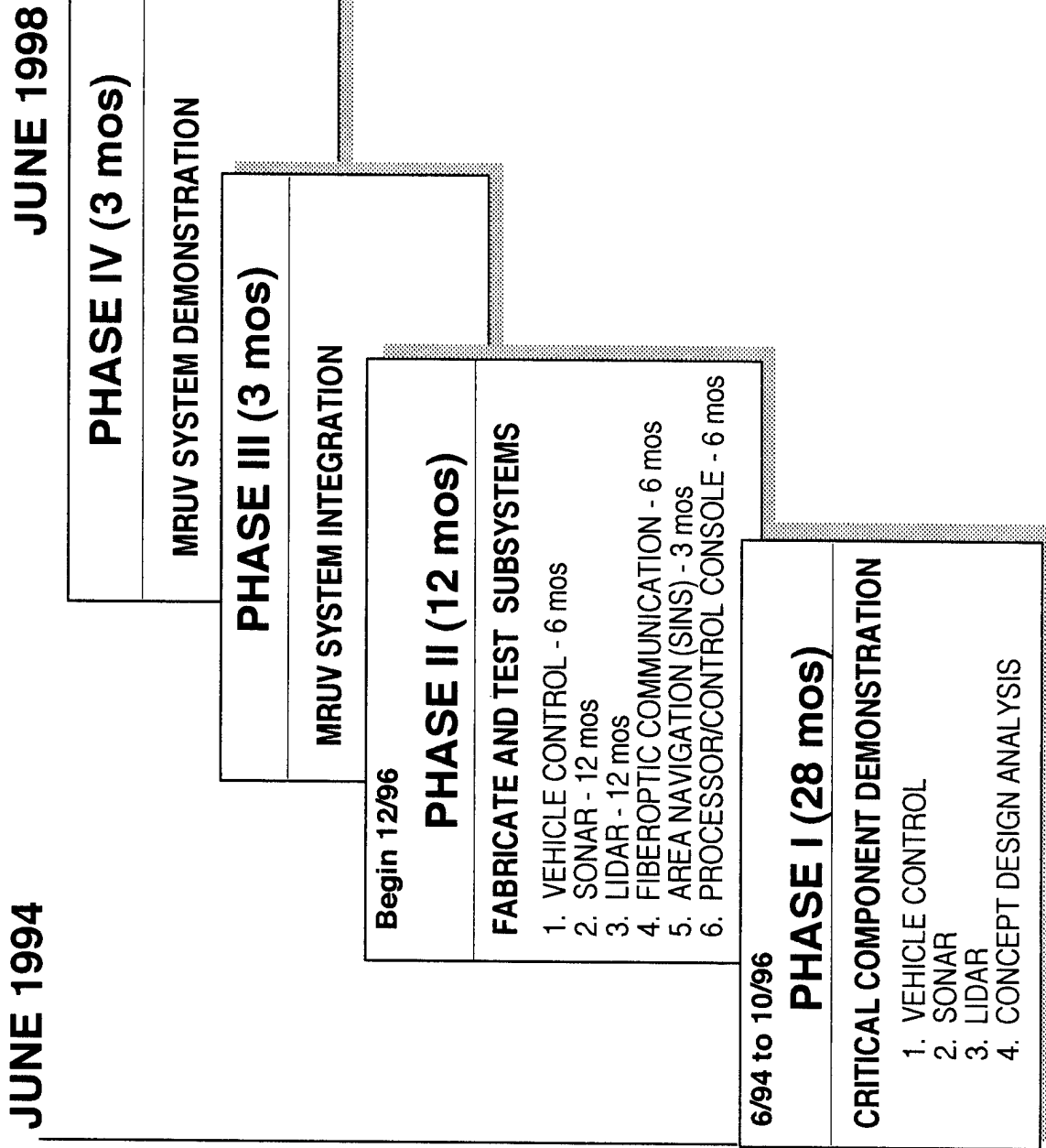
Diameter - 4.88 inches

Weight - 37 lb.

Neutrally buoyant



# MRUV TECHNOLOGY ROADMAP



# CONCLUSIONS

---

MRUV Phase I demonstrated:

A small UUV, depth and altitude sensors which could be integrated into a modular offboard bathymetric and optical sensor platform for reconnaissance of Very Shallow Water in the near term (1 to 2 years).

UUV stability and control and sonar technology which could be integrated into a small, affordable mine reconnaissance UUV for VSW in the near term.

This MRUV could be produced in meaningful quantities (50-100 units) in the near-term (2 to 3 years) at a production unit cost of ~ \$ 150 K (FY 96 \$).

Over the mid-term (3-4 years), a more autonomous version of the MRUV which would use an acoustic link rather than an expendible fiberoptic tether would afford a more cost effective and flexible capability which could be deployed by surface, subsurface and air delivery

# The First Mine Countermeasure Devices with Superconducting Magnets

Vladimir Karasik

Babcock & Wilcox, Product Development Department, P. O. Box 785, Lynchburg, VA 24505, USA

Gennady Agapov, George Kurlijandtsev, Vladimir Tsikhon, Vladimir Malginov,  
Anatoly Rusinov, Valentine Matokhin and Michael Sidorov

P. N. Lebedev Physical Institute, Leninskiy Prospect 53, Moscow 117333, Russia

Alex Konjukhov and Vitaly Vysotsky

Russian Research Center "Kurchatov Institute", Kurchatov Square, Moscow 123182, Russia

**Abstract**—Compact superconducting magnets, capable of operating with high current densities in a persistent mode, provide a possibility to create organic, high speed, very effective and explosion stable Mine Countermeasures (MCM). The first MCM devices with superconducting magnets (SM) were developed in USSR during the period between 1976-1988. A joint team with contributors from the USSR Academy of Sciences, Industry and Navy executed the program. Self-propelled, towed by helicopter and mounted on armored troop carrier MSM with SM were created and successfully tested on the Black Sea Fleet, Baltic Sea Fleet and Land Army fire grounds.

## I. INTRODUCTION

In 1974 during mine-sweeping operations in the Middle East the US Navy demonstrated the first airborne MCM in history: MK-105 hydrofoil sled towed by helicopter. In comparison with existing at the seventieth low-speed sea-borne cumbersome magnetic sweeps it was challenge.

The new high speed MCM was much more effective and safe for the screws, than towing by ship long cables-tails, or huge electromagnets.

The International MCM community operating on the Red Sea and in the Canal of Suez at that time, including the USSR team, was very impressed. It happened during the Cold War, when the Arms Race was taking place. The impact of MK-105 on mine-sweeping was discussed at the USSR Navy Head Quarters, and it was decided to attract the USSR Academy of Sciences for creating modern MCMs, based on the latest achievements of Sciences and Engineering. In the middle of July 1976 three stars Admiral-Engineer P. Kotov, Deputy of USSR Navy Commander-in-Chief, visited famous P. N. Lebedev Physical Institute, where included in the members of staff were five Nobel Prize Laureates. The Admiral was familiarized with R & D of superconducting magnets at the Prof. B. Vul Laboratory. After short discussion, a preliminary decision was made to design and test SM's for

mine-sweeping. To provide P. N. Lebedev Institute with funding, Admiral P. Kotov ordered his assistants to prepare Draft of USSR Government Decree. The Decree covering R & D for a MCM with superconducting magnet on board was approved in Kremlin in October 1976. As a result, 45 new jobs were created at the P. N. Lebedev Institute Applied Superconductivity Group. The funding was provided for purchasing in USA Helium Refrigerator, SQUID Magnetometer and the most powerful during that time the SM for the superconducting materials testing, generated a magnetic field of 16.5 T. On the Black Sea in Sevastopol, the Main Base of Black Sea Fleet a temporary joint team to provide sea trials was settled on. The P.N. Lebedev Institute was the Primer Contractor. The Subcontractors were: the USSR MCM R & D Company; producers of hydrofoil vehicles, cryogenic equipment, superconducting wire, and Russian Navy Warfare Center. At that time phase of SM R&D there didn't exist any experience in operating on board and able to withstand a naval mine explosion SM. It was necessary to solve the following scientific, engineering and logistic problems:

- develop a SM capable of operating on board in the persistent current mode without quench in severe conditions of vibration and shocks;
- solve the problem of stress and strain distribution in SM's winding after manufacturing, cooling and during operation;
- evaluate the strain impact on SM stability;
- develop and design a superconducting switch (SS);
- develop and design a 100% reliable SM protection system against over-heating and transient voltage during quench;
- develop and design current leads with very low heat flow from the environment to the helium bath;
- develop splices and joints with low transition resistance;
- develop a SM and SS manufacturing process;
- develop, design and manufacture equipment necessary to provide research and routine test of SM and SS in P.



N. Lebedev Institute, including cryostats with removable cover, helium refrigeration and recovery system, instrumentation, acquisition system, data recording and analyzing system, and related software;

- develop and design a cryostat with low cryogen losses for on board operation by a shock overload of 30 g;
- design a cryostat cradle, able to absorb shock by mine explosions;
- develop and design an automatic, on board operating "two buttons" power supply (PS) to charge and discharge the SM during MCM mission;
- develop and design in cooperation with industry containers for liquid helium transportation on board the mother ship;
- develop in cooperation with Navy Tactics a new MCM with SM application to mine-sweeping, including the problem of ship magnetic signature emulation;
- provide Industry and Navy personnel with training.

Our schedule was aggressive: it was necessary during a period of two years to design, manufacture and test on the Black Sea an acting prototype of the MCM with a SM on board towed by helicopter.

Members of our team were young and enthusiastic. They understood the importance of our deal and worked hard and were very productive. Scientific research, SM, SS and PS development were made in parallel.

Most of the researchers were graduates from a new college for gifted students in Moscow Suburb and from Moscow University. The team also included top level engineers from Industry and experts from the Navy enriched by experience of local wars in Vietnam and in the Middle East. The USSR Government Military Department, the Navy, the President of USSR Academy of Sciences and many top rank officers paid attention to our activity.

## II. PLACE OF TEST, PLATFORM AND TACTICS

### 1. Place of Sea Trial

The main base of the Black Sea Fleet, Sevastopol was founded at the 1784. This city-fortress built from white limestone survived two sieges and two invasions: the first at the middle of the last century, and the second during the World War II. Two times it was ruined and recovered. In the National Cemetery close to Black Sea coast are buried sailors from Great Britain, France and Russia, killed during the Crimean War. On the hills overlooking Sevastopol from the South are Memorials of World War II and multiple graves of Russian soldiers and sailors. In downtown are monuments of Submerged Ships, and Eternal Fire near the Unknown Sailor Grave. Sevastopol is

a beautiful City located on slopes of picturesque hills surrounding the Main and South Bay. It is Navy Base with more uniformed people than civilian. Sevastopol is a Russian National Memorial, City of Russian Naval Glory.

In 1939-1941 a group of scientists and engineers led by future President of USSR Academy of Sciences Professor Anatoly Alexandrov and future father of Russian nuclear bomb Professor Igor Kurchatov carried out here the degaussing of ships out. On June 22, 1941 German pilots parachuted naval magnetic mines in Main Sevastopol Bay. Ten years later one of these mines detonated at a distance of 30 feet from the anchored battleship "Novorossiysk". The ship capsized and sunk in a few minutes. More than one thousand sailors were killed by this disaster.

All Black Sea Fleet MCM ships, helicopters and Air Cushion Vehicles were based on Sevastopol and on its vicinity. The MCM Engineering Department and Workshop were also located in Sevastopol.

Sevastopol was the right place for the first MCM with SM sea trials.

### 2. Platform

A carrier for MCM with SM should be high speed and explosion-stable. Two types of high speed vessels can survive a naval mine explosion: hydrofoil boat (HB) and air cushion vehicle (ACV). The main destructive force by underwater explosion is a shock wave. In the HB motion only the hydrofoil is submerged, but the boat hull is above the sea surface. The density of metallic hydrofoil is more than water. Additionally the hydrofoil is relatively thin and therefore transparent for shock waves. Traveling through hydrofoil the shock wave experiences only refraction without essential absorption. Air has density much less than water, and therefore shock wave experiences reflection from sea surface and travels back without HB hull damage. Only a water mushroom, raised by a naval mine detonation can damage the HB, but the probability of collision is equal to the ratio of the mushroom-effective area to the mine-sweeping zone area.

The HB was invented in the small Russian town of Sormovo, suburb of old city Nizhny Novgorod on the Volga river. The HB is very popular in Russia as transportation on sea, the Volga basin and in Siberian. Russian sea board guard is also equipped by high speed HB.

Sormovo HB Shipyard was responsible for the design and production of the HB-SM carrier for our project.

Two HB Project Leaders from Sormovo took part in our activity in Sevastopol : Yu. Garanov and V. Konjakhin.

ACVs are also explosive stable as they "fly" above the sea surface. We used Russian ACV AIST as our system carrier and high speed tug boat of HB with SM on board. The AIST division was based on Donuslav, a distance fifty

miles from Sevastopol. Later events, happened during sea testing, including a naval mine explosion, demonstrated that the HB and ACV were good choices for our task.

### 3. Tactics

A High Speed MCM with SM on board was intended to sweep magnetic and magneto-acoustic naval influence mines in shallow water (200'-60'), very shallow water (60'-12') and surf zone. It should be *Organic MCM*, operated from the mother ship deck. Typical mission parameters: 2 hours between missions, 0.5-2 hours round trip transit, 4-8 hours on station, including SM charge and discharge. Mission time depends from a tug type: an ACV can provide much longer mission duration than a helicopter. SM should operate 3-5 days continuously without cryostat refilling by liquid helium.

The problem of ship magnetic signature emulation during mine-sweeping can be solved in three different ways depending on the level of mine sophistication:

#### 1. Sweeping by one point magnetic dipole.

Magnetic signature of one forward moving point magnetic dipole is described by formulas:

$$B_R(t) = 2mVt/[a^2 + (Vt)^2]^2 \quad (\text{radial component}) \quad (1)$$

$$B_T(t) = m a/[a^2 + (Vt)^2]^2 \quad (\text{transversal component}) \quad (2)$$

$$B_M(t) = m\{4(Vt)^2 + a^2\}^{1/2}/\{a^2 + (Vt)^2\}^2 \quad (\text{magnitude}) \quad (3)$$

where B - magnetic field in gauss

V - platform speed in cm/s

a - minimum distance between mine and magnet in cm

m - dipole magnetic moment in gauss cm<sup>3</sup>

t - time in second is variable:  $-\infty < t < \infty$ ,

V, a, m are parameters.

$dB_R/dt$ ,  $dB_T/dt$  and  $dB_M/dt$  are time derivatives of right side of equations (1), (2), and (3).

The main parameters of magnetic signature:

- transit time by fixed mine sensitivity,
- number of extremes,
- amplitudes of extremes,
- time separation between neighbor extremes.

From (1), (2), and (3) it follows, that magnetic field decreases with distance as  $a^3$  and magnetic field derivative decreases with distance as  $a^4$ .

The most influence mines are analyzed  $dB/dt$  signal. Therefore width of sweeping zone of one moving forward

MD by fixed mine sensitivity increases very slowly (as  $m^{1/4}$ ) by dipole magnetic moment increasing.

The second disadvantage of one FMMD is small amount of extremes on its magnetic signature (one or two). If the influence mine has a ship counter, it is necessary to pass the same corridor not less than 20 times.

The third disadvantage of one FMMD is the fixed shape of MS, which makes the possibility of different ship MS emulation difficult.

#### 2. Sweeping by one forward moving and rotating MD

Magnetic signature of forward moving and rotating with constant speed MD is described by formula: (a MD's longitudinal axis is parallel to the sea surface, MD rotates around the vertical axis),

$$B_M^{\text{rot}}(t) = m \left[ \frac{\{4(Vt)^2 + a^2\}^{1/2} \cos(\omega t + \phi)}{\{a^2 + (Vt)^2\}} \right] \quad (4)$$

where  $\omega$  - rotation speed,  $\phi$  - phase shift

Forward moving and rotating MD has the following advantages:

- starting from some distance  $dB/dt$  decreases not as  $a^4$ , but as  $a^3$ , and the sweeping zone width is more;
- number of extremes is unlimited, and depends on mine sensitivity and speed of rotation, therefore the necessity for mine-sweeping number of tacks is less;
- increased possibilities for the accurate ship MS emulation exist.

#### 3. Two ( or more ) point magnetic dipoles, following each other in keel water

Magnetic signature of system from two moving by speed V on distance 2L in keel water point MD with DMM = m each, can be described by formula (3) by replacing time variable  $t \rightarrow (t \pm L/V)$ :

$$B_{2M} = B_M(t - L/V) + B_M(t + L/V) \quad (3^*)$$

With the help of two or more, moving in keel water MD, it is possible to accurately emulate most of ships MS. In this case MD operation should be controlled by computer, solving the reciprocal problem of Magnetostatic: a reproduction of known ship MS by system of forward moving magnetic dipoles and selecting the appropriate solution. Free parameters are: magnitude of every MD, dipoles magnetic axis orientation in space, and distance between MD.

We successfully tested during the sea trials in 1967-1988 two approaches to mine-sweeping: one forward moving MD and one forward moving and rotating MD.

The problem of mine-sweeping by two or more MD's moving in keel water was only a preliminary estimated: the possibility to solving the above mentioned reciprocal problem of Magnetostatic was discussed with experts on Applied Mathematics in Moscow University and M. V. Keldysh Institute of USSR Academy of Sciences. In parallel on Sormovo ship yard a possibility of towing by helicopter two HB's in keel water was studied.

Twenty years passed, and this study was continued: now under development in France a programmable low speed magnetic sweep "STERN" with six resistive magnets, moving in keel water. "STERN" can exactly reproduce the MS of any ship. This system should be towed by tug boat equipped by power supply at a speed 6-8 knots, but it has no ability to sweep in very shallow water.

### III. SUPERCONDUCTING MAGNETS FOR OPERATION ON BOARD IN SEVERE CONDITIONS OF VIBRATION, SHOCK, AND EXPLOSION

SM operates only a few degree below critical temperature  $T_C$ . Below  $T_C$  exists superconductivity, SM has zero resistance, and can operate in persistent current mode, when the circuit is closed by the SS. In persistent mode time of current decay in SM  $\tau$  depends on transition resistance  $R$  in joints and magnet inductance  $L$ :  $\tau = L/R$ . In our SM  $\tau = 10^9$  sec. or more than 30 years.

Above  $T_C$  magnet loses superconductivity and becomes resistive with resistance equal to resistance of copper matrix of conductor in which Nb-Ti filaments are imbedded. Typically this resistance is 10-50 Ohms by very low temperature, and current in magnet should disappear within a few seconds, generating heat.

Unfortunately enthalpy of all materials by SM operating temperature 4.2 K is very small  $\sim 10^{-4}$  J/g. As SM with high current density (it is our case) is surface cooled, and winding does not have enough good heat conductivity, the negligible amount of heat, generated for different reasons in any location inside the winding, will cause transition to the resistive state or quench. In magnets with high current density the quench is an irreversible process.

During quench all liquid helium, stored in the helium vessel dumps, and sweep should be delivered to the mothship for refilling and control testing.

Quench is a complicate process. Starting in some place as a result of thermal disturbance, resistive zone in winding propagates with velocity, depending on current density in copper matrix, its resistivity, heat capacity, heat

conductivity, and thermal resistance of insulation between turns and between layers. If the process is not accelerated artificially, all stored magnetic energy will be converted to heat in a small part of winding. Additionally as a result of misbalance between resistive and inductive voltage, high voltage will be generated in the quenched area, and unprotected from overheating and high voltage the magnet will fail resulting in possible conductor damage and insulation electrical breakdown.

It is clear, that for SM normal operation, it is necessary to minimize the probability of thermal disturbances, and protect magnet from quench. The thermal disturbances have different origins, but the main origin is any movement accompanied by friction. To control all displacements, it is necessary to know the stress and strain distribution in winding during SM operation, and provide appropriate magnet design.

It is necessary also to protect the magnet by quench from overheating and transient voltage.

#### 1. SM Design and Manufacturing

Basic element of our SM was one modulus. The number of module, assembled together, can change, starting from one up to fifteen. Every SM was assembled from the identical module, but in different mine-sweeping systems dimensions and/or number of module being different.

Winding of every modulus was wound with tension on stainless steel coil form. Tension was close to yield point of Cu-Nb-Ti conductor. A standard machine was accommodated for this process, used by transformer producer, adding programmable system, which controlled the conductor tension. During winding the strain in the coil form was measured by a strain gauge and compared with a pre-calculated value.

The coil form was insulated from winding by G10 sheets. Every layer was coated by epoxy, filled by quartz sand. As a spacer between layers we used a glass fabric, impregnated by epoxy. The winding was additionally prestressed by a band, wound over the last conductor layer. The band was manufactured from stainless steel wire under high tension. After manufacturing and removing from the mandrel the winding was compressed between two powerful "springs": the compressed coil form and the stretched band. Compression was kept also after cooling up to 4.2 K and during SM operation.

To know what is going with a prestressed SM, his elastic-plastic behavior was simulated analytically and by computer. As a result, a stress and strain distribution in our layered structure on all stages of manufacturing and operation was calculated [1], [2]. Our task was to prevent any motion in winding during the SM charge and operation. But to prevent the local crack of epoxy by low temperature is very complicate. In properly designed SM

this process, accompanied by local heat generation and by SM quenches, has to be irreversibly completed after a few charges ( "SM training"). After that the SM is operational. The number of quenches by "training" certifies the quality of the SM: than less quenches, than better SM; the best magnets operate without training.

After manufacturing every magnet modulus was tested and certified. Assembled SM module were packed between end plates and fixed by tie-rods. In some cases the neighbor coil frames were joined by welding to prevent their displacement (alignment) in high magnetic fields, accompanied by quench. Conductor splices were joined by soldering and fixed over the module bands on the G10 sheet covered by copper foil.

It was solid SM design, able to survive in severe environmental conditions. Dimensions, stored energy and parameters of our SM are described in [2].

## 2. SM protection by quench

If the whole winding quenches instantly, the stored in magnetic field energy converted into the heat uniformly around the winding volume. If we will neglect by heat exchange between the winding and liquid helium bath, the winding temperature  $T$  after quench can be calculated from the energy balance:

$$\frac{1}{2}\mu_0 \int_0^\infty B^2 dV = V_0 \int_{4.2}^T C_V dT \quad (5)$$

where  $B$  is magnetic induction, in  $T$

$C_V$  is the winding average heat capacity, in  $J/^\circ K m^3$ ,

$V_0$  is the winding volume, in  $m^3$ ,

$\mu_0$  is magnetic permeability of vacuum.

From calculations and experimental data it is known [2] that for middle-size SM, typical for mine counter-measures application,  $T \leq 200 K$ , much less than ambient temperature (  $290 K - 300 K$  ). Therefore an instant quench is safe: the winding is protected against the over-heating and high transient voltage.

Instant quench is possible, if velocity of quench propagation  $V \rightarrow \infty$ . But in a real SM  $V$  is limited .

Velocity of quench propagation along conductor, if the heat exchange with the helium bath is negligible, can be described by formula:

$$V = J \{ \rho \lambda / C^2 (T_C - T_0) \}^{1/2} \quad (6)$$

where  $J$  is current density in  $A/m^2$ ,

$\rho$  is resistivity in  $\Omega m$ ,

$\lambda$  is conductor heat conductivity in  $W/m^\circ K$ ,

$C$  is heat capacity in  $J/^\circ K m^3$ ,

$T_C$  is superconductor critical temperature in  $^\circ K$ ,

$T_0$  is superconductor temperature before quench in  $^\circ K$ .

Velocity of quench propagation through conductor insulation ( from turn to turn, or from layer to layer ), can be described by formula:

$$V_\perp = V \{ \lambda_\perp / \lambda \}^{1/2} \quad (7)$$

where  $\lambda_\perp$  is insulation heat conductivity, typically 1000 times less than by copper.

It is possible to estimate by formulas (6) and (7), that quench propagation velocity along the conductor by typical current density in copper matrix  $200 - 500 A/mm^2$  and  $\Delta T \approx 2-3K$  is a few tens meters per second. Velocity of quench propagation through insulation between turns and layers is tens times less. Now we can describe a quench dynamics: a thermal disturbance (in many cases it is enough  $10^{-3} J$ ) generates a quench embryo. Quench starts to propagate through winding in all directions. As the propagation velocity is different in different direction, and winding has an annular shape, the quenched volume has the shape of a curved hot dog. Heating inside of the hot dog is going quickly and resistivity increases. In middle-size SM impregnated by epoxy all stored energy dumps inside of the hot dog in a period of a few seconds. Now, to calculate the average temperature  $T_{hot}$  inside of the hot dog, we must apply formula (5) not to  $V_0$ , but to the hot dog volume  $V_{hot}$ . As the  $V_{hot}$  is much less than  $V_0$ ,  $T_{hot} \gg T = 200K$ . The result is very bad: damage to insulation, electric breakdown, and conductor melting. It becomes clear the only way to protect autonomous SM, operating in the persistent current mode, is to provide *quench of whole winding in a very short period of time*.

There are two possible solutions of this problem:

1. A heater, co-wound with basic conductor, and quench detection system, switching the heater on instantly after the quench start.
2. SM winding subdivision with shunts.

Our motivation to provide a SM with protection was an accident, which happened in our laboratory in 1978, when R & D of the SM with high current density was on the initial stage. We manufactured and tested a big for that period of time SM for mine-sweeping, and our team was prepared to move to the Sevastopol for a sea trial.

It was decided to do a magnet's final indoor test, to be sure that our system operates properly. While performing the test, the magnet was damaged during quench. The magnet was dismantled, and in one modulus of the 15 a cave was discovered: conductor was melted and partly evaporated inside of a sphere of the radius one cm .

After this case we started a fundamental study of quench propagation in SM with high current density. During testing every modulus was supplied by multiple thermocouples, small heaters and voltage taps, located in different parts of the winding. We started quench in an appointed place to measure a quench propagation velocity in different directions. We also performed quench computer simulations, and compared the theoretical and experimental results [2]. On the base of long term quench studies, we decided to choose SM protection by subdivision with shunts. Quench in a subdivided magnet moves with high rates of speed and acceleration, like a snow avalanche: winding sections are inductively coupled, the magnetic flux, which disappeared in one section is supported by neighboring sections. Current in this sections increases above some critical value, generating quench in the whole of their volumes momentarily. After that quench moves to the next section. It was shown in our laboratory, that approximately all energy stored by some winding section is converted to heat inside this particular section. The thermal energy distribution in winding is much more uniform than in SM without subdivision: if the volume of every section is chosen correctly, the conductor temperature after quench is never more than 200K and the SM will never fail by quench. We created and published the methodology of quench protection system calculation, design, manufacturing and testing.

### 3. Superconducting Switch

The superconducting switch (SS) controls the SM mode of operation: to charge or discharge the magnet, it is necessary to open the switch. In the persistent current mode the SS is closed. To provide high resistance in non-superconductive state, SS manufacturing should use a conductor with high matrix resistivity, for example Cu-Ni-Nb-Ti alloy. During SS is superconducting, current flows through Nb-Ti filaments, imbedded in the matrix. When SS is resistive, the main part of the current flows through the matrix. SS transition to resistive mode is activated by a heater and controlled by attaching to the SS winding thermocouple. SS was wrapped by glass fiber blanket, impregnated by epoxy, and its cooling was provided by blanket heat conductivity. The SS design was optimized to provide the minimum liquid helium losses. More detail information about SS, used in our SM is found in [3].

### 4. Explosive and Vibration Stable Cryostat for SM

By the cryostat design we tried to provide the very low liquid helium losses and ability to withstand pulse overload and vibrations. We used the experience of space cryogenic engineering: a stainless steel helium vessel was suspended by neck inside the vacuum vessel,

manufactured from Al alloy and fixed by six G10 strip with the tensile strength approximately 80 kN each. The suspension can withstand 30g impulse load and vibration typical by sea trial. Losses of liquid helium during operation in severe sea condition were 10% per day (24 hours). Cryostat was supplied by current leads with force cooling during the magnet charge and discharge. During the operation in persistent mode a heat flow through current leads into the helium vessel was negligible. The helium vessel was protected against radiation by two shields and by MLI. The vacuum vessel was suspended by shock absorbers on the cryostat cradle.

### 4. Power Supply and Control System (PSCS)

Power supply and control system were integrated together, and operated as an autonomous "two buttons" device. Two of our MCM PSCS were controlled by cable, four others per radio. PSCS automatically provided full cycle of magnet charge and discharge:

1. SS transition from superconducting to resistive state.
2. SM charge, raising currents up to appointed value.
3. Current stabilization.
4. Transition to persistent current mode.
5. Magnet discharge on a load, placed outside cryostat.

Feedback was provided by four sensors:

1. Thermocouple attached to the SS.
2. Level of liquid helium gauge.
3. Magnetic sensor.
4. Acoustic sensor.

The primary supply in two PSCSs was an AC generator, and in four other PSCSs was a battery.

Additional information about our PSCS can be found in [3].

## IV. THE FIRST MINE COUNTERMEASURE DEVICES WITH SUPERCONDUCTING MAGNET ON BOARD

### 1. MCM Prototype, Towed by Helicopter

The first MCM Prototype was tested in the fall of 1977 in the Sevastopol area. The SM has dipole magnetic moment (DMM)  $0.85 \cdot 10^5 \text{ Am}^2$  and was installed together with PSCS on hydrofoil sled. Sea testing included the following:

1. SM operation on moored hydrofoil sled.
2. Towing MCM by ship at different speed, sea conditions, and at different angles between sea waves and sled heading.
3. Recording MCM magnetic signature on the Black Sea Fleet Magnetic Control Station by magnetic sensors, placed on sea bed.

#### 4. Towing hydrofoil sled by helicopter.

Points 1-3 of the test program were successfully realized. After that a "traffic accident" occurred: During trials on October 17, 1977, an inexperienced helicopter pilot doubled the tow speed and lifted sled above the sea surface. Within a few seconds, the sled struck the water surface at a speed 70 knots and was heavily damaged. The estimated overload was 30 g. But the SM survived and continued to operate in the persistent current mode in a head-over heels position. This accident demonstrated our SMs striking vitality.

#### 2. Testing of Self-Propelled MCM Prototype and the First Mine-Sweeping with SM

The SM with the DMM =  $0.6 \cdot 10^5 \text{ Am}^2$  and radio-controlled PSCS was mounted on a hydrofoil sled supplied with a 100 HP engine. Planted on sea bed was a training magneto-acoustic influence mine, connected by cable with an on shore operating signal processing and recording station. The hydrofoil sled with the SM on board moved along a straight line, at different distance from the influence mine. Noise, necessary to activate the mine acoustic sensor, was generated by the screw propeller. Twelve passes were performed with distances on the beam of the sled from 5 to 45 m at a speed of 21 ks. The width of the sweep zone was 70m. A mine was "detonated" every time, when dB/dt at the mine location was  $\geq 15 \text{ } \gamma / \text{s}$ .

#### 3. Testing of MCM Prototype with a Rotating SM

Rotating SM with DMM =  $0.94 \cdot 10^5 \text{ Am}^2$  and PSCS was mounted on a self-propelled sled. Cryostat with SM was rotated by an electric drive. Also developed was a new power supply unit with a superconducting filter, which was connected in series with the magnet and used to eliminate the ripple of the half wave rectifier, which was mounted on the head of the dewar. The magnetic signature of moving forward and rotating SM was recorded on May 12, 1981 at the Navy Control Magnetic Station in the Main Sevastopol Bay. All ninety nine MS were in good agreement with MS calculated by formula (4).

#### 4. Prototype of MCM Device for Anti-Tank and Anti-Landing Mines

In 1984 a rotating SM with DMM =  $1.15 \cdot 10^5 \text{ Am}^2$  together with PSCS were mounted on board an amphibious armored troop-carrier. The interactions of the rotating SM with troop-carrier ferromagnetic hull and magnetic field screening were pre-calculated and measured during testing. During December 5-18, 1984, mine-sweeping of anti-tank magnetic mines was carried out at the Land Army's Fire Ground not far from

Moscow. A hard frost, heavy snowfall, and the jolting of the carrier did not have negative influence on SM operation. During the testing on December 18th, training anti-tank mines were successfully "detonated". Mines were laid at different traverse distances from troop-carrier track and along the direction of its forward motion. Mine magnetic sensor sensitivity was 0.1 gauss or 0.1 gauss / s. At a forward speed 10km / hr and a magnet rotating frequency of 0.5 hertz, the sweep zone had an elliptical shape with a major axis of 9 m and a minor axis of 8 m.

#### 5. Sea Trials and Commissioning of MCM Device Towed by Helicopter.

All components of this device were manufactured by Soviet Industry as a result of technology transfer. SM had DMM =  $0.6 \cdot 10^6 \text{ Am}^2$ . The primary power supply was a 400 hertz AC generator, installed on the mother ship or onboard the helicopter. SM was charged through the tow-cable. SM and PSCS were installed on hydrofoil sled inside water-proofed compartments. The SM carrier had the following basic parameters: a length of 8.65m, a height of 2.5m, a beam of 2.5m, and a gross weight of 2,300 kg.

The operating speed was 22-27 knots, the tow-line tension at a speed of 22 knots was 1,600 kg. The tow-line length was 250 m. Testing of the system was conducted on the Black Sea during 1982 - 1984.

The program of preliminary testing included 40 towing tests, in all more than 200 hours of towing by ship and helicopter in open sea, under good and bad weather conditions. The MCM was delivered to the station on the upper deck of the mother ship, a 266 M class ocean mine-sweeper.

After preliminary testing the following program of final testing and certification was performed:

1. Mooring test.
2. 13 towing by ship and 17 by helicopter Mu-14BT.
3. SM cooling and charging cycle parameters control.
4. PSCS cycling test.
5. MCM magnetic and acoustic signature recording.
6. The most interesting was explosion stability test.

An influence naval mine, charged by 435 kg of TNT was laid on the depth of 19.5 m. The mine was detonated at a distance 25 m from the hydrofoil sled, towed by helicopter with operational SM and acoustic emitter. After explosion the sea surface had the protuberant shape and the sled crossed at the center of protuberance. A few second later the protuberance exploded in a water mushroom 50 m in height behind the sled. It was verified by remote control that SM survived and continued to operate in persistent current mode.

7. Minefield sweeping. A defined area of water was secretly mined with influence naval bottom mines. The

mine-sweeping was carried out by equidistant parallel sweeping tacks. All mines were successful detonated.

8. The sled with SM on board was transported by air from a heliport to the open sea and placed on sea surface for mine-sweeping: it was demonstrated that mine-sweeping in littoral zone possible without the need for mother ship.

After successful completing final testing, the first MCM device with on board superconducting magnet was certified and added to USSR Navy Armory by Order of the Commander in Chief of the Navy.

#### 6. Remote Controlled Self-Propelled MCM on Air Cavity with Rotating Superconducting Magnet

USSR Navy baseline in Mine Warfare was MCM diversification: helicopter is vulnerable to anti-helicopter mines and to weather conditions. Additionally helicopter is very expensive and controlled by screw vehicle.

Therefore the Navy Head Quarters in Moscow prepared a Draft of Government Decree for R & D of unmanned high speed self-propelled MCM with SM on board. Decree was approved in Kremlin in 1987.

To cut period of R & D, it was decided to use as a basic approach the project of the fifteen tons displacement high speed border guard vehicle, using to pursue fishermen-smugglers on the Russian Far East. The vehicle travels on air cave under keel, and she had improved explosion stability.

The following equipment was mounted on board:

- a 1,000 HP diesel engine,
- the main and auxiliary electric generators,
- steering and engine operations remote control system,
- radio receiver and radio transmitter,
- radar emission reflector,
- rotating SM with  $DMM = 1.27 \cdot 10^6 \text{ Am}^2$ ,
- remote controlled PSCS,
- remote controlled a cryostat rotation equipment,
- a fire extinguishing and other auxiliary equipment,
- a wheel-house for manned operation.

The maximum speed was 50 knots, operational sea conditions was up to wind force 6.

The vehicle was built, equipped, and commissioned by an old and deserved Russian ship-yard, created in San-Petersburg at the beginning of our century.

MCM sea trials started in the Gulf of Finland in 1988.

The vehicle was an outstanding example of superior anti-mine warfare operational in severe weather conditions, able to emulate ship magnetic signature, high speed, explosion stable, unmanned, remote controlled, with wide sweeping zone. Additionally the vehicle heading can be pre-programmed.

But the high potential of the new MCM was not realized in former Soviet Union: Michael Gorbachev turned the

rudder of Russian History, Perestroyka started, and funding of all military programs was drastically cut. Along with other programs this very interesting project, the MCM of the twenty first century was killed.

#### 7. Air Cushion Vehicle AIST as a MCM Platform

With landing operation it is very desirable to have an organic MCM, included in the battle group. Therefore it was decided to use Russian ACV AIST as a transportation platform and tug-boat. AIST is a high speed landing craft, able to accommodate the armored troop-carriers or tanks, therefore on her deck was enough free place for the hydrofoil sled with SM along with containers with liquid He and  $N_2$ . AIST had ability to lower the sled on the sea surface, take sled in tow during MCM missions, and lift back on board. Successful mine-sweeping by the MCM, described above in point 5 and towed by AIST was realized during 1982-1984 on the Black Sea Fleet fire-ground.

## V. CONCLUSION

In 1976-1988 in former USSR the MCM devices with explosion and vibration stable superconducting magnets with high current density, operating in the persistent current mode were designed, manufactured and tested. A new generation MCM devices allows defeat of the modern sea ground, anti-tank and anti-landing mines in shallow water and in surf zone.

## ACKNOWLEDGMENT

The authors would like to acknowledge many enterprises, research institutes, naval units, war ships, and helicopter crews that contributed their efforts to the successful completion of the MCM with SM program.

## REFERENCES

- [1] V. R. Karasik, A. A. Konjukhov, G. I. Agapov, A. I. Rusinov, G. S. Kurljandtsev, V. S. Vysotsky, V. N. Tsikhon, V. A. Malginov, V. V. Matokhin, and M. V. Sidorov, "The First Mine Countermeasure Devices with Superconducting Magnets," *Advances in Cryogenic Engineering*, Vol. 41, pp. 1057-1068, 1996.
- [2] V. S. Vysotsky, A. A. Konjukhov, A. I. Rusinov, and V. R. Karasik, "Design and Coil Protection of the High Current Density Autonomous Superconducting Magnets for Mine Sweeping", *Advances in Cryogenic Engineering*, Vol. 41, pp. 1069-1076, 1996.
- [3] V. S. Vysotsky, A. A. Konjukhov, V. N. Tsikhon, and V. R. Karasik, "Persistent Mode Switches and Automatic Power Supplies for Autonomous Superconducting Magnets", *Advances in Cryogenic Engineering*, Vol. 41, pp. 1077-1086, 1996.

# Acoustic Time Series Simulator (ATSS) Synthetic Environment Applied To Mine Warfare

J. W. Kesner

Alliant Techsystems, Inc.

1911 North Fort Myer Drive, Suite 601

Arlington, VA 22209

**ABSTRACT** - Over the last several years, the Office of the Oceanographer of the Navy (N096) has sponsored the development of a coherent high fidelity synthetic environment for stimulating sonar systems. In January 1996 this stimulation capability was demonstrated using an emulation of the signal processor and display for the detection sonar of the AN/SQQ-32 Advanced Minehunting Sonar. The demonstration featured free-play vignettes in which ship and sonar operating parameters were interactively selected in response to real time displays. This paper describes the Acoustic Time Series Simulator (ATSS) and presents several examples illustrating the influence of the ocean environment on the operation of the AN/SQQ-32 detection sonar.

## INTRODUCTION AND ATSS CONCEPT

The Acoustic Time Series Simulator (ATSS) represents a simulation technology for high fidelity synthetic signal generation. ATSS is designed to provide the U. S. Navy with the ability to accurately represent the influence of the ocean environment on the performance of naval system sensors. The objective is to create a synthetic environment for sensor-based systems which is indistinguishable in all significant respects from the real environment. This allows a performance evaluator to conduct a first order assessment of notional systems without the time and cost burden of at-sea experiments. Using state-of-the-art underwater acoustic propagation models and environmental databases, ATSS creates virtual signals for stimulating the signal processing suite of any existing or notional sensor system. Within the limits of the physics included in the models and the accuracy of the databases, these virtual signals are statistically indistinguishable from real signals. ATSS generates high-fidelity time series representations of both signal and masking acoustic fields in real time from unscripted scenarios using massively parallel computers. Both impulsive and phase-modulated source waveforms are modeled. For active systems, time series of echo, reverberation, and noise are computed.

The development of ATSS has been accomplished in the context of the Synthetic Environment (SE) concept. The environment in this context comprises both the physical

environment model in which it is desired to immerse the system, and a real-time evolving acoustic scene in which emitters and targets can be placed in a desired way. The function of the SE process is to synthesize acoustic signals which present the evolving scene to the processor in an entirely realistic manner. In order to accomplish this realism at the highest achievable level of fidelity, both the environment and the elements of the scene are modeled at the basic physics level, using the highest fidelity databases and models available. The basic concept is shown in Fig. 1.

The emphasis in the inclusion of a real sensor-based system and its operator is on real-time interaction in which both external inputs, such as those derived from an ongoing war-game activity, and the actions of the operator, influence the subsequent evolution of the scene. An operator in this environment thus perceives the synthetic environment as a 'virtual reality' in which he acts in a fully realistic manner in response to what is presented as a set of entirely realistic conditions.

The computational kernel of the synthetic environment is ATSS. Within ATSS, synthetic sensor signals are generated by direct convolution of modeled source waveforms with the coherent impulse response of the ocean medium between each acoustic source and the sensor array. In order to create realistic signals at the sensor, it is essential that all propagation paths between source and sensor be modeled, and also that the impulse response be updated as source and sensor move through the medium. ATSS computes the contribution of target paths, reverberation paths, and ambient noise to the composite sensor signal. Each path is characterized by an individual impulse response derived from a range-dependent propagation model. Both the target model and the scattering kernel used in reverberation include all possible combinations of incident paths and scattered paths.

ATSS has the capability to model an elastic semi-infinite sediment layer in forward scatter, while the bottom scattering function for reverberation computations depends on a complete description of a layered visco-elastic bottom with a directional surficial roughness spectrum.



The basic organization of ATSS is to use a propagation engine for separate echo, noise, and reverberation modules. For a given source waveform, the time series produced by each module are then combined to form a simulated time series of received complex acoustic pressure at a receiver. The simulation is done on an element level basis, so for a complex sensor consisting of many individual receivers, beamforming can be done in a post-processing step.

Sponsored by the Office of the Oceanographer of the Navy and managed by the Office of Naval Research, the Navy's Advanced Environmental Acoustic Support (AEAS) program has developed the high frequency ATSS simulation capability, primarily directed to tactical frequencies (nominally about 1 kHz to 100 kHz). While the high frequency version of ATSS has been primarily designed for the frequency regime of a few tens of kHz, it is also possible, within the limitations of the system and judicious choice of parameters, to extend its range into the lower frequencies.

### ATSS SYSTEM ARCHITECTURE AND MODELING

The system architecture for ATSS has been designed to be flexible, scalable, and modular. This architecture allows ATSS to be applied to a wide variety of sonars, scenarios, and applications, such as operator training, sonar testing, mission rehearsal, area assessment, simulation based design, processing algorithm design and evaluation, and computational acoustics evaluations. Depending on the hardware available and the requirements set by the intended use of the signals generated by ATSS, the system architecture can adjust to the size of the problem and the required speed of execution.

ATSS is prepared to receive updates to each platform's course, speed and location from an outside resource. This enables ATSS to couple with any independent, sophisticated motion model (e.g., through Distributed Interactive Simulations). At present, these updates come from a high fidelity track model.

The current version of ATSS has been designed to run on Intel's series of massively parallel computing machines, namely the Hypercube and the Paragon. The different physical contributors to the final acoustic time series have been separated computationally into separate modules within the architecture. Each ATSS module generates a particular aspect of the acoustic time series (noise, bottom reverberation, target echo, etc.). ATSS is designed in a hierarchical and modular way, enabling the operator to turn on or off each ATSS module.

Fig. 2 illustrates the overall ATSS system concept for active cases. The following sections describe each of the major modeling components which make up the system. A more complete description of ATSS is given in [1].

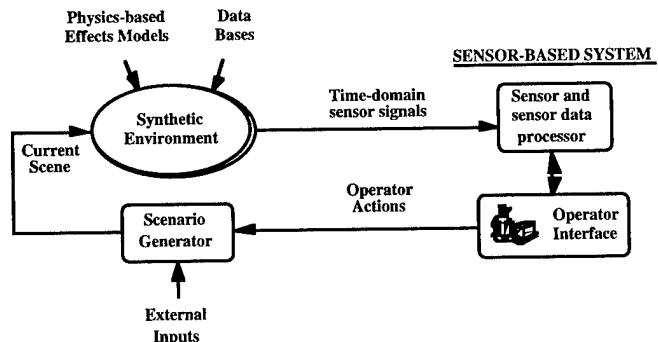


Fig. 1. Synthetic Environment Concept

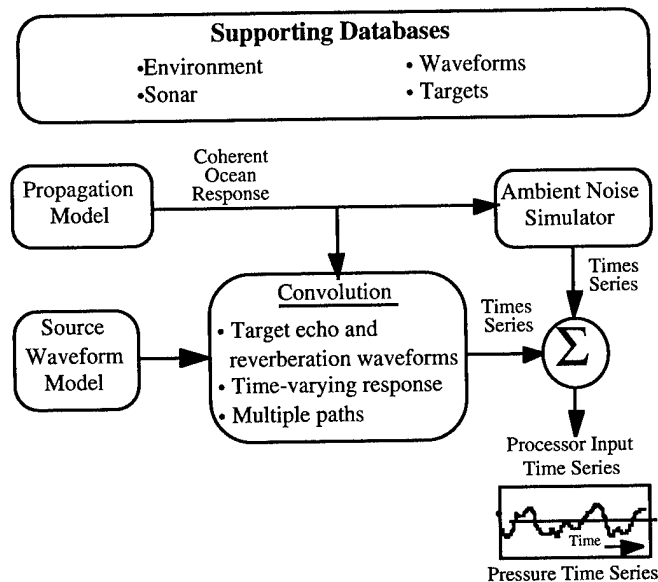


Fig. 2. Active Acoustic Time Series Simulator Concept

### A. Supporting Databases

#### Environment

The environment for ATSS may be range, azimuth, and depth dependent. Navy standard databases are used to supply bathymetry, bottom composition, and sound speed profile (SSP). For interactive free-play exercises the appropriate environmental data for the current locations of interest are used in ATSS. Separate databases are provided for SSP, bathymetric data, bottom characteristics (compressional and shear velocities and attenuations and density), and bottom roughness. Each database includes data specified at a number of different geographic locations in order to provide for range and azimuth dependence. For high frequency cases where the resolution of the databases may not be high enough to adequately represent bottom spatial features, the bottom databases are augmented with statistically generated data to represent realistic features.

## *Sonar*

The source and receiver descriptions are inputs to ATSS so that it may accommodate a variety of sonars. Information about individual element locations, orientations, sizes, shadings, and utilization for transmit and receive beams is included in the sonar database. The number of receive beams and their locations are also specified. If beam level rather than element level time series are desired, then beam patterns can be precomputed and stored as additional databases for the sonar.

## *Waveforms*

A library of wavetrains and wavetrain sections is available for the source array to use. Each wavetrain is made up of a set of wavetrain "sections". Individual pulses are each a separate "section" of a wavetrain, each with its own relative start time. The wavetrain information includes number of wavetrains, number of wavetrain sections, and for each section the pulse type, pulse length, center frequency, bandwidth, and windowing type. Additional information provided within the ATSS system includes timing information about when to transmit a given wavetrain and sampling rate information. Signal strength and transmit beampattern effects are also applied.

## *Targets*

Target types, sizes, locations, and echo characteristics are included in the target database. In order to accommodate a variety of targets, a T-matrix representation of each target is utilized. Frequency dependence and aspect dependence are included. Externally supplied target data can be accepted.

## *B. Propagation Model*

The high frequency version of ATSS uses the DELTA [2] ray model. A parallel version of DELTA has been developed for use on Intel Hypercubes and Paragons. In the future, other propagation models can be integrated into ATSS in a straightforward manner, if desired.

## *C. Source Waveform Model*

The source waveform time series is created using the specified pulse and wavetrain information. For frequency domain convolutions the source waveform time series is converted into the frequency domain using a fast Fourier transform.

## *D. Ambient Noise Simulator*

The ambient noise time series for each element of the sonar array is generated from a Cholesky decomposition of the Cross-Sensor Covariance Matrix (CSCM). The CSCM at the receiver is created from the noise directional spectrum, which is computed using the environmental data, the directional radiation characteristics for the noise sources, and the propagation model.

## *E. Convolution*

The source waveform is convolved with the target echo and reverberation responses to produce the time series due to an active source. The following paragraphs describe the computation of target echo and reverberation responses.

### *Target Echo*

The high frequency target scattering model incorporates multipath effects and allows for scattering between any two ray paths incident upon the target. The DELTA ray-tracing code is used to model the propagation, directly yielding the receiver field decomposed into plane wave components. The scattered field is also expressed as plane waves for coupling with the propagation model. ATSS is configured to accept a matrix of target scattering kernels. This matrix may be produced with any suitable scattering kernel. The incoming field and outgoing field can be connected by a precomputed T-matrix describing scattering between each incoming and outgoing plane wave.

### *Reverberation*

At each frequency of interest the monostatic reverberant pressure in a single beam due to a source is found by integration over the bottom. The region of integration is limited by attenuation of the return, either by the beampattern, or by the range between the source and receiver. For each point on the bottom the integrand is the sum of the product of pressures along all combinations of two paths, one from the source out to a point on the bottom, and one from the point on the bottom to the receiver, multiplied by a complex scattering kernel. The scattering kernel, which includes the effects of small scale roughness (texture) and large scale roughness (bathymetry), gives the ratio of incident to scattered pressures for a plane wave. A perturbation theory model is used.

## ATSS APPLICATION TO AN/SQQ-32 MINEHUNTING SONAR

The AN/SQQ-32 minehunting detection sonar was chosen as a representative system to demonstrate the utility and features of ATSS for tactical frequencies and for an actual Navy sonar system. A minehunting scenario in shallow water is of great interest and provides a challenging environment in which to produce synthetic signals. In a January 1996 demonstration ATSS produced time series data for the AN/SQQ-32 detection sonar in real time in an unscripted free-play exercise for a minehunting scenario in the Persian Gulf. In this paper, however, only single ping snapshots will be presented which address the comparison of simulated data with real data and the effects of the environment on the sonar data. Additional information about the AN/SQQ-32 can be found in [3].

### *A. Comparison Of Simulated Data With Real Data*

Recorded data from Narragansett Bay were used for comparison with ATSS simulated data. The Narragansett

Bay data were taken on a calm day and in a region that was relatively flat. The SSP was estimated to be isothermal. An environmental assessment of this area was performed by Paul Bucca of the Naval Research Laboratory, Stennis Space Center, in order to estimate the geophysical parameters of the bottom, the bathymetry, and the sound speed structure. Fig. 3 shows a direct comparison between ATSS simulated data and AN/SQQ-32 data for one ping out of the recorded data set. The horizontal axis corresponds to bearing and the vertical axis corresponds to range or time. Since there was no ground truth data available on the spatial variability of the bottom, we created this variability for the simulation. The comparison illustrates that we can create realistic bottom features which have range and azimuthal variability, and that ATSS can handle this variability. Fig. 4 compares real and simulated data as a function of time for a single beam with no time varied gain (TVG). The real data overlay the simulated data. Note that the roll-off with range (time) and the signal statistical variability are in good agreement with the real data. Since there was a spherical (1 meter diameter) mid-water column target in this beam in the real data which shows up at about 1.16 seconds, a simulated target of the same size was also inserted into the simulated data at approximately the same range. The simulated target echo level and duration match quite well with the real data. The strong echo in the real data which shows up at about 0.2 seconds was not simulated. Fig. 5 is an expanded look at the target region in range and bearing comparing real data with simulated data. Note that the simulated target echo structure looks very much like the real data, including multipath effects and sonar beam pattern overlap effects. The fact that the simulated target was placed at a different bearing is irrelevant.

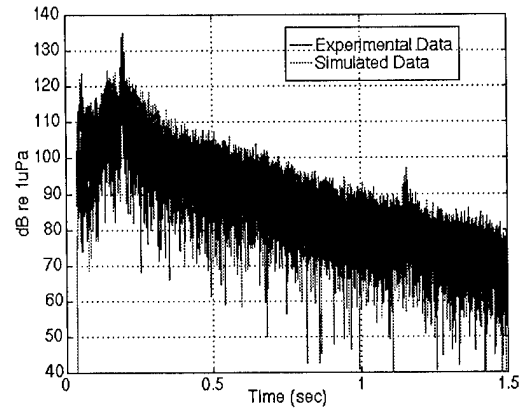


Fig. 4. Comparison of Simulated and Real Data for a Single Beam

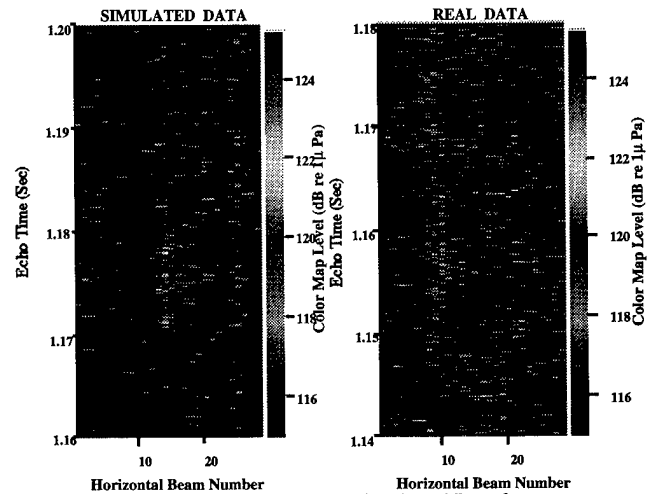


Fig. 5. Comparison of Simulated and Real Data from a Mid-Water Column Spherical Target

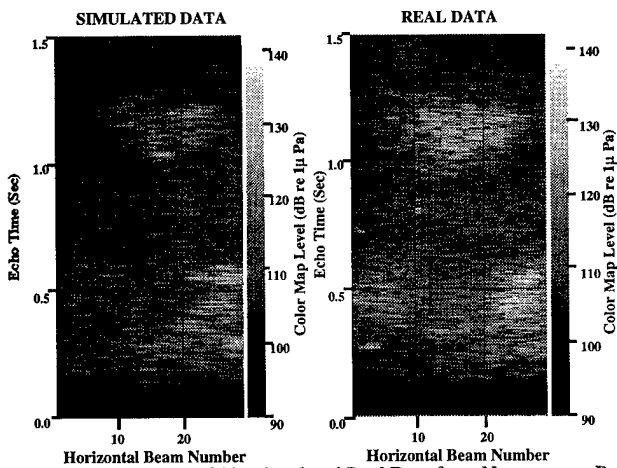


Fig. 3. Comparison of Simulated and Real Data from Narragansett Bay

### B. Environmental Effects Upon AN/SQQ-32 Data

ATSS has been exercised with a number of different environments for the AN/SQQ-32 detection sonar. Examples from some of these environments will be shown. Since the spatial resolution of present environmental databases is not fine enough to provide the detail needed for minehunting sonar displays, we create realizations of the bottom which overlay the bathymetric data. For higher resolution minehunting systems we can also simulate the fine structure which would be needed. As an example, Fig. 6 shows a small patch of correlated ripples.

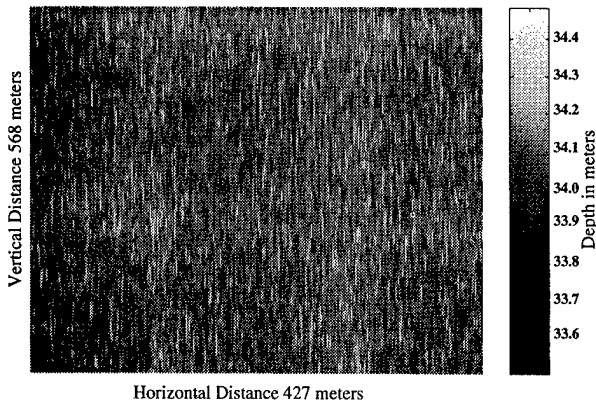


Fig. 6. Simulated Realization of Bottom Ripples

As an aid in illustrating the influence of the ocean environment upon AN/SQQ-32 data, a "test pattern" of nine targets was placed in the field of view of the sonar with deep, shallow, and mid-water target depths. The three targets closest to the sonar are arranged in depth deep (port), mid-water (middle), and shallow (starboard). The next row is arranged shallow (port), deep (middle), and mid-water (starboard). The row farthest from the sonar is arranged mid-water (port), shallow (middle), and deep (starboard). Fig. 7 shows the test pattern arrangement in a Persian Gulf environment. The background in the figure represents bottom roughness variability. Fig. 8 shows the hull mounted sonar images with TVG for depression/elevation (D/E) angles of 4° down and 12° down for this same region. The right hand side of the figure shows the echo return for one of the center beams for each D/E angle. Note that the relatively low roughness and high roughness areas are visible in the images. Note also that deep targets are more detectable at shorter ranges and shallow targets are more detectable at longer ranges.

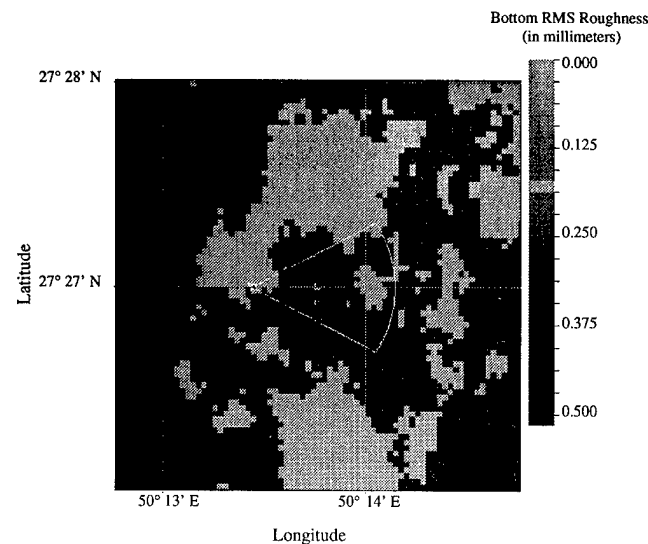


Fig. 7. Test Pattern of Targets

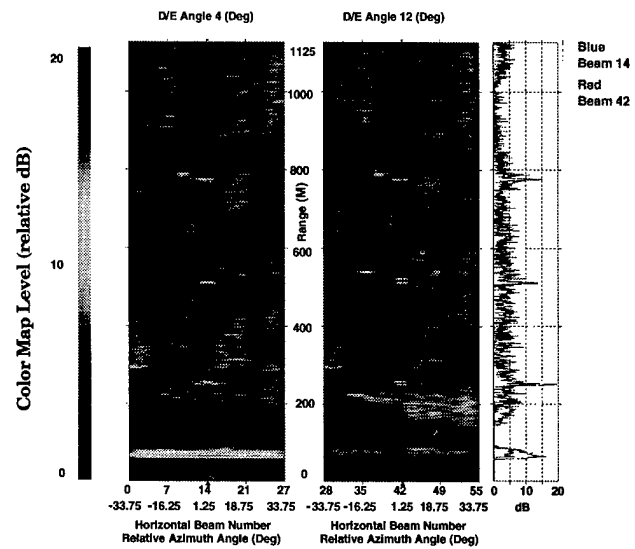


Fig. 8. Images of Target Test Pattern for Hull Mounted Sonar Using TVG in Downward Refracting Environment

Fig. 9 shows the same data except without TVG so that the reverberation background can be seen directly. As expected, the short range reverberation is stronger for the 12° down D/E angle than for the 4° down D/E angle. The summer SSP for this region is strongly downward refracting and the water depth is approximately 55 meters.

The environment for Fig. 10 is strongly upward refracting due to a layer of fresh water over salt water with a water depth of 30 meters. The sonar is again hull mounted. Comparing the 4° down D/E angles of Figs. 9 and 10 we see that the reverberation is weaker in the upward refracting case of Fig. 10 even though the bottom is closer. Note that shallow targets are also seen better in the upward refracting case.

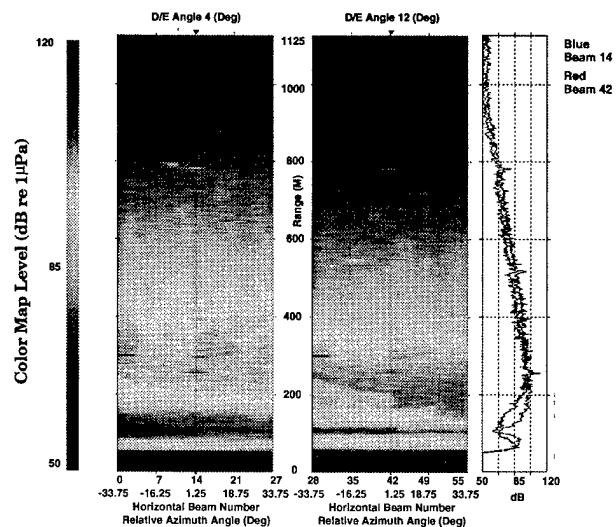


Fig. 9. Images of Target Test Pattern for Hull Mounted Sonar in Downward Refracting Environment

The water depth for Fig. 11 is also 30 meters and the sonar is hull mounted, but this environment has constant salinity. Comparing Figs. 10 and 11 we see that the upward refracting SSP which results from the fresh water intrusion reduces the bottom reverberation compared to the constant salinity case. There is also a significant difference between the two D/E angle results for the fresh water intrusion case due to the upward refracting SSP. Target detectability is adversely affected by the upward refracting SSP, especially for the deep and mid-water targets as seen with the 4° down D/E angle. Multipath effects are especially noticeable in the mid-range deep target echo. The environment for Fig. 12 is also constant salinity isothermal water but 100 meters deep and the sonar is hull mounted. As expected, short range reverberation is weaker in the deeper water of Fig. 12 than in the shallower water of Fig. 11. The target echo structure is also more compact in the deeper water case.

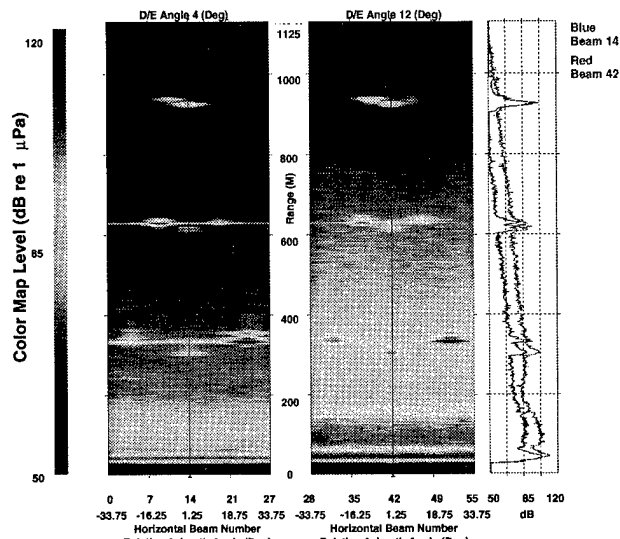


Fig. 10. Images of Target Test Pattern for Hull Mounted Sonar in 30 Meter Water with Fresh Water Intrusion

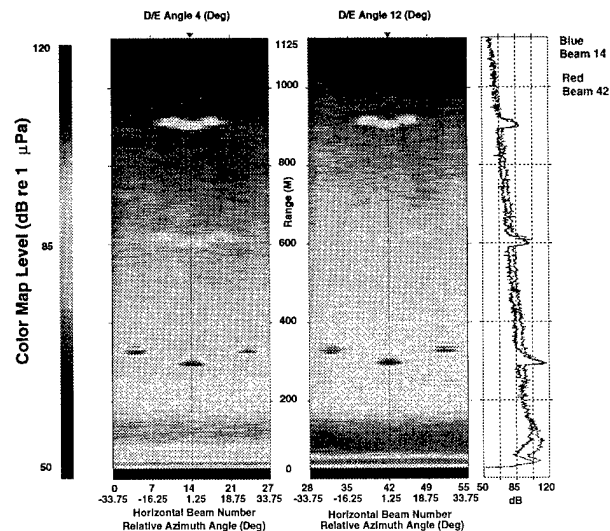


Fig. 11. Images of Target Test Pattern for Hull Mounted Sonar in 30 Meter Water with Constant Salinity

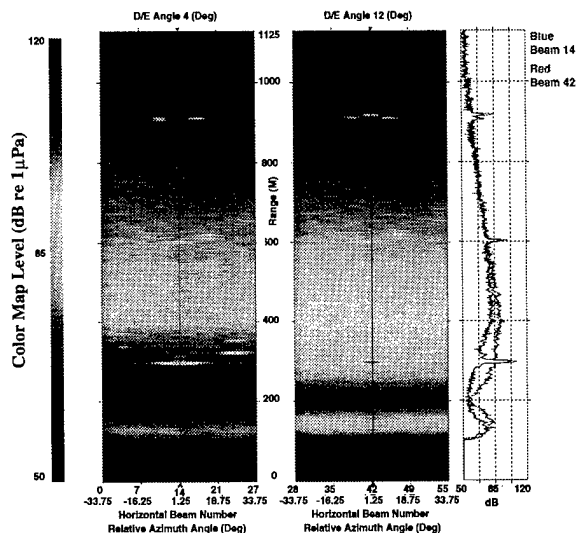


Fig. 12. Images of Target Test Pattern for Hull Mounted Sonar in 100 Meter Water

A comparison between operating with the sonar in hull mounted mode and with the sonar towed 20 meters off the bottom is shown in Figs. 12 and 13 for isothermal water 100 meters deep. Note the differences in the reverberation shape versus time (range) for the two cases. In the deep tow case the reverberation drops off rapidly and then stays relatively constant due to multipath dominance and very little change in grazing angle. The mid-range deep target shows more multipath spreading in the "deep" tow case than in the hull mounted case. Comparing the 12° down D/E angle images we see that at short and medium ranges the deep target is seen better with the sonar hull mounted and the shallow target is seen better with the sonar towed near the bottom. At short range the choice of D/E angle makes a big difference with the sonar hull mounted. The short range deep target is not seen with the 4° down D/E angle and the short range shallow target is not seen with the 12° down D/E angle.

Some environments make mine detection very difficult. A rough rocky bottom has been simulated in Fig. 14 and the targets in the test pattern are very difficult to see. Even with TVG to average out the background, as shown in Fig. 15, the targets are still hard to find.

## SUMMARY AND CONCLUSIONS

I have described an acoustic time series simulator, ATSS, which embodies state-of-the-art ocean acoustics, ocean environmental databases, and parallel computer architecture to generate acoustic time series in real time. These time series are useful for stimulating actual and proposed naval system sensors, in order to aid in system design and performance studies, and for a wide variety of additional applications, such as operator training, area assessment, computational acoustics studies, and the design and evaluation of signal processing algorithms. As an example, I have described the stimulation of an AN/SQQ-32

minehunting sonar using ATSS to produce realistic displays of reverberation, targets, and bottom features under a variety of environmental conditions. I have illustrated the strong influence of the ocean environment on the operation of the AN/SQQ-32 detection sonar.

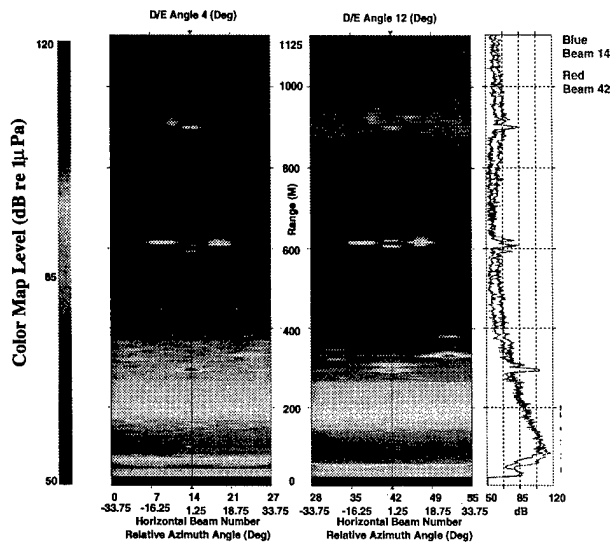


Fig. 13. Images of Target Test Pattern for Sonar 20 Meters Above the Bottom in 100 Meter Water

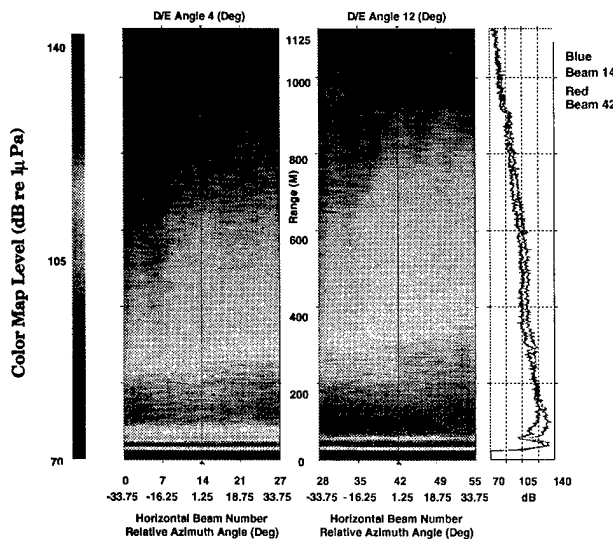


Fig. 14. Images of Target Test Pattern for Hull Mounted Sonar over Rough Bottom

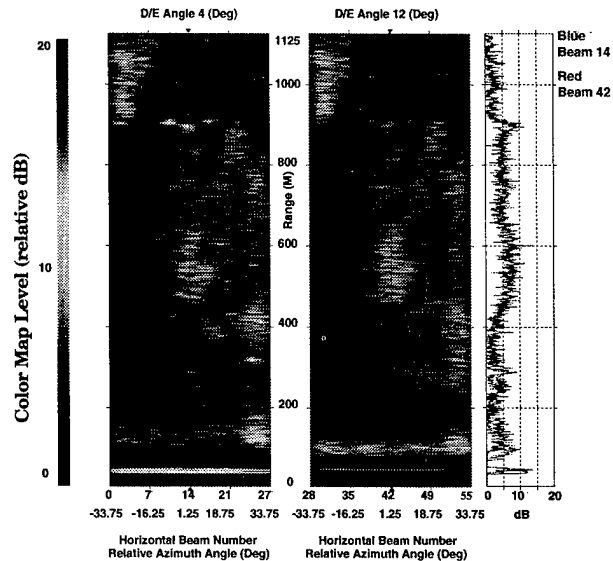


Fig. 15. Images of Target Test Pattern for Hull Mounted Sonar Using TVG over Rough Bottom

#### ACKNOWLEDGMENT

Grateful appreciation is expressed to Dr. Ed Whitman, N096B, Office of the Oceanographer of the Navy, U. S. Naval Observatory, Washington, DC, for his sponsorship of the high frequency development of ATSS under contract number N00014-92-C-6009 as part of the AEAS program, with contributions and guidance by Barry Blumenthal, AEAS Program Manager, and Jack McDermid of NRL (Naval Research Laboratory), Stennis Space Center, Mississippi. Many thanks are due Pat Pitt of ARL/UT for providing recorded data of the AN/SQQ-32 detection sonar and to Aubrey Holston of NSWC/CSS for providing details of the detection array geometry and operation.

#### REFERENCES

- [1] John Davies, Lewis Dozier, Bill Kesner, Pierre Lallement, Xavier Zabal, "ATSS: Acoustic Time Series Simulator (U)," (Confidential), JUA(USN) 46, No. 4, (1996) (Secret), in press.
- [2] Dozier, L. and Lallement, P., "Parallel Implementation of a 3-D Range Dependent Ray Model for Replica Field Generation", in *Full Field Inversion Methods in Ocean and Seismo-Acoustics*, pp. 45-50, Diachok et al. (eds), 1995 Kluwer Academic Publishers.
- [3] S. Patrick Pitt, H. Sam Richardson, "Development And Testing Of The AN/SQQ-32 Minehunting Sonar System: A Systems Engineering Perspective (U)," (Confidential), JUA(USN) 43, No. 3, 1207-1238, (1993) (Secret)



# Automated Mine Identification using Wavelet Analyzing Functions

Mark E. Lehr  
and  
Keh-Shin Lii

UCR, Department of Statistics  
Riverside, California 92521

Wavelets have become a popular tool in many areas of research. They produce a linear orthogonal decomposition of a time signal or image which simplifies statistical quantification. Analysis of time signals in the areas of radar and acoustics can be done in the wavelet domain directly. Whereas, multiscale processing involved in imaging utilizes high pass filter stages for segmentation purposes. Algorithms and procedures can be developed to automate the process of classification and identification using the inherent properties associated with the wavelet decomposition process.

Keywords: wavelet, multiresolution analysis, classification, identification, segmentation, peak signal to noise ratio.

## I. INTRODUCTION

Wavelets have certain advantages as an analysis tool because of their scale properties [Rosenfeld, 1990], noise reduction capabilities [Donoho et al. 1995], image segmentation potential [Mallat, 1996 and Canny, 1986], and computational efficiency [Press et al. 1992]. They are also easily quantifiable in a statistical sense since they are implemented as FIR filters which are orthonormal transforms. [Akansu and Haddad, 1992]

A signal in the time domain can be decomposed as linear combinations of functions such as

$$X(t) = \sum_k s_{j,k} \phi_{j,k}(t) + \sum_{j=1}^J \sum_k d_{j,k} \psi_{j,k}(t). \quad (1)$$

Only very special pairs or families of functions result in an orthogonal series approximation. These special pairs must satisfy exacting mathematical conditions [Mallat, 1989 and Daubechie, 1992] which have scale and shift properties

$$\begin{aligned} \phi_{j,k}(t) &= 2^{-j/2} \phi(2^{-j/2}t - k), \\ \psi_{j,k}(t) &= 2^{-j/2} \psi(2^{-j/2}t - k). \end{aligned} \quad (2)$$

The father wavelet  $\phi$  and mother wavelet  $\psi$  are by construction

$$\begin{aligned} \int \phi_{j,k}(t) \phi_{j,k} dt &= \delta_{k-k'}, \\ \int \psi_{j,k}(t) \psi_{j',k'} dt &= \delta_{j-j'} \delta_{k-k'}, \\ \int \phi_{j,k}(t) \psi_{j,k}(t) dt &= 0. \end{aligned} \quad (3)$$

An analogous decomposition can be obtained in higher dimensions for utilization in image processing. The multidimensional wavelet is created in the same way that 2 dimensional Fourier transforms are developed. As in equation (1) we have

$$\begin{aligned} I(x,y) &= \sum_{m,n} s_{j,m,n} \Phi_{j,m,n}(x,y) \\ &+ \sum_{o} \sum_{j=1}^J \sum_{m,n} d_{j,m,n} \Psi_{j,m,n}^o(x,y) \end{aligned} \quad (4)$$

and similarly for the scale and shifts of equation (2)

$$\begin{aligned} \Phi_{j,m,n}(t) &= 2^{-j} \Phi(2^{-j/2}x - m, 2^{-j/2}y - n), \\ \Psi_{j,m,n}^o(t) &= 2^{-j} \Psi^o(2^{-j/2}x - m, 2^{-j/2}y - n). \end{aligned} \quad (5)$$

The approach to implement this decomposition involves a multiresolution dyadic filter bank [Vetterli and Kovacevic, 1995]. Successive stages of high and low pass filters form the basis for this orthogonal decomposition.

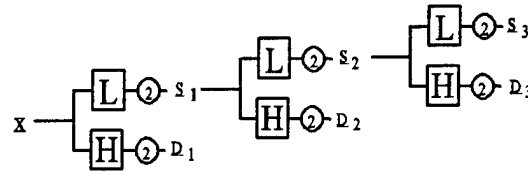


Figure 1 Multiresolution Dyadic Filter Bank

These filters are down sampled by 2 such that at stage 1 they give

$$s_{1,n} = \sum_k l_{2n-k} x_k, \quad d_{1,n} = \sum_k h_{2n-k} x_k \quad (6)$$

This forms a transformed vector at each stage arranged as

$$Y_1 = \begin{bmatrix} s_1 \\ d_1 \end{bmatrix}, \quad Y_2 = \begin{bmatrix} s_2 \\ d_2 \end{bmatrix}, \quad \dots, \quad Y_m = \begin{bmatrix} s_m \\ d_m \\ \vdots \\ d_1 \end{bmatrix} \quad (7)$$

## II. AUTOMATION

### A. Time Signal Decomposition

The probability density function of certain types of complex radar and acoustic targets, and many kinds of



environmental effects can be represented by chi-squared distributions. [Skolnik, 1980] This implies that the distribution of a signal with additive noise characterized by a chi-squared distribution is

$$\underline{X} = \underline{X}_s + \underline{X}_n \quad (8)$$

with

$$x_{n_i}/A_n \xrightarrow{d} \chi_2^2, \quad x_{s_i}/A_s \xrightarrow{d} \chi_2^2 \quad (9)$$

The transformed signal of the noise in the wavelet domain is simply the sum of scaled independent chi-square variables  $k$  with  $c$  filter coefficients per stage

$$\frac{s_j}{A} \xrightarrow{d} \sum_{i=1}^{c^j} k_i^{l^j},$$

$$\frac{d_j}{A} \xrightarrow{d} \sum_{i=1}^{c^j} k_i^{hl^{j-1}}. \quad (10)$$

To distinguish a signal from noise we can set a threshold or envelope value for various filter coefficients. The probability of detection and false alarm are easily calculated using this distributional assumptions and the threshold levels. Refer to the Appendix for other distributional characteristics.

Figure 2 shows simulated targets with noise. The first panel indicates an ideal representation without noise or cross-sectional fluctuations. The second panel is a realization of the signal in a noisy environment under the conditions of Swerling type II. If the signal is continuously transformed using a bank of high and low pass filters in a dyadic bank (i.e. wavelets) then at specific times the output of the low pass filter would be obtained in the lower left panel. The statistical characterization of the signal is itself a chi-squared random variable. A threshold can be set dependent upon the noise level estimated from a first stage filter. Once this is done then the last panel indicates the reconstructed signal of the inverse transform. Because of the threshold placement and this realization, the signals have been properly identified.

The next Figure shows a similar time signal but composed of ramp and step functions. The ramp function can be analyzed in a like manner which obtains the same result. In this particular case, the wavelets used

are matched filters. Threshold levels can be set in exactly the same manner since the distributional characteristics can be estimated. However, we can distinguish patterns of signals by taking into account combinations of components in the wavelet domain. The decomposition indicates how this might be accomplished.

## B. Image Decomposition

Wavelets can also be utilized in an imaging environment. However, at this point they are modestly used for segmenting the image by detecting edges [Mallat, 1996]. Given an image that has been decomposed into its wavelet matrix

$$W = \begin{bmatrix} d_1^h & d_1^d \\ s_1 & d_1^v \end{bmatrix} = \begin{bmatrix} d_1^h & & d_1^d \\ d_2^h & d_2^d & \\ s_2 & d_2^v & d_1^v \end{bmatrix}, \quad (11)$$

then

edges can be found or determined by finding the magnitude and phase of the high pass filter components such as

$$Mag_{j,m,n} = \sqrt{(d_{j,m,n}^h)^2 + (d_{j,m,n}^d)^2 + (d_{j,m,n}^v)^2},$$

$$Phase_{j,m,n} = \text{atan} \frac{d_{j,m,n}^v + d_{j,m,n}^d \cos(\pi/4)}{d_{j,m,n}^h + d_{j,m,n}^d \sin(\pi/4)}. \quad (12)$$

By chaining the maximums of the magnitudes there are edges which correspond to the vectors that are perpendicular to the phase.

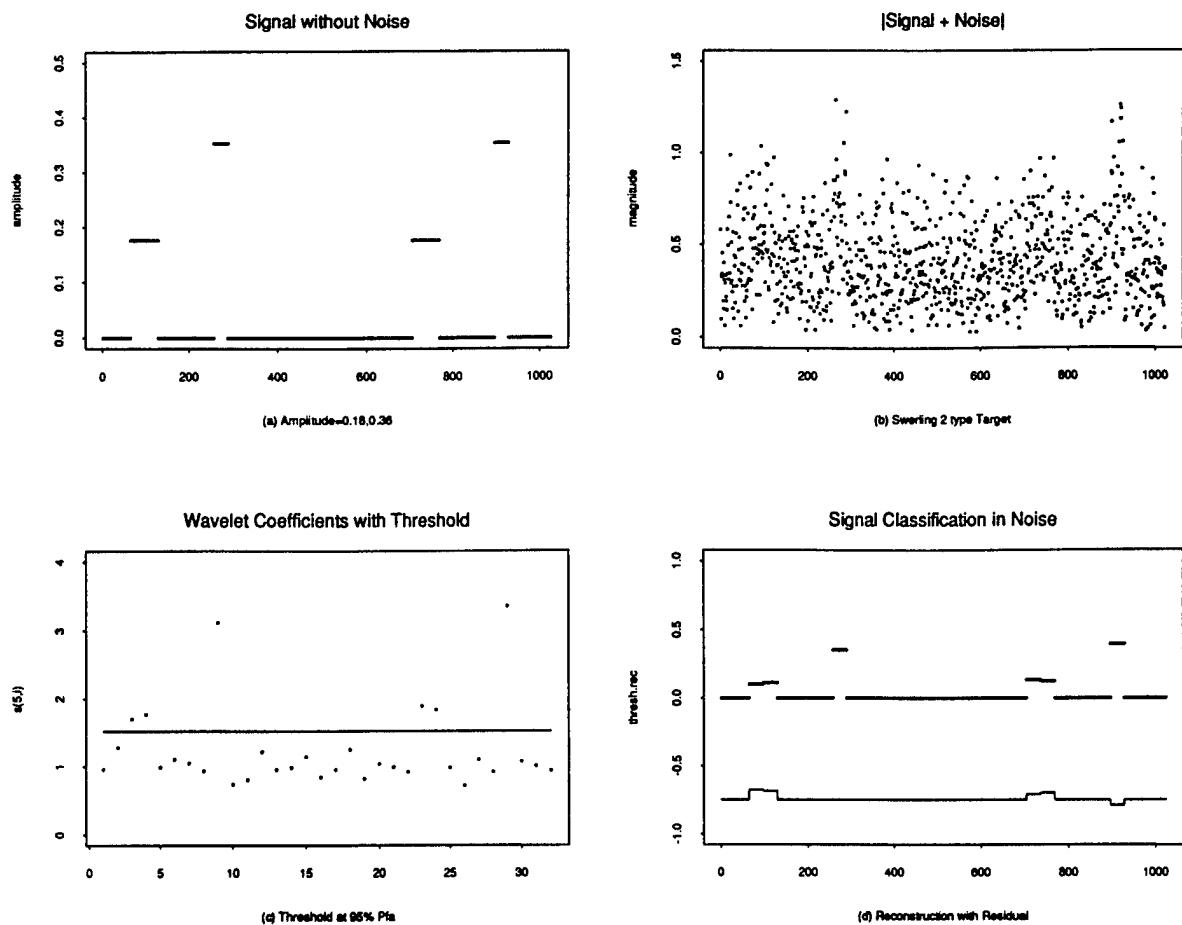
$$Mag_{j,m,n}^{\max} \xrightarrow{\infty} Mag_{j,m+\eta,n+\tau}^{\max} \Rightarrow$$

$$Mag_{j,m,n}^{\max} \rightarrow Mag_{j,m+\eta,n+\tau}^{\max} \perp Phase_{j,m,n} \quad (13)$$

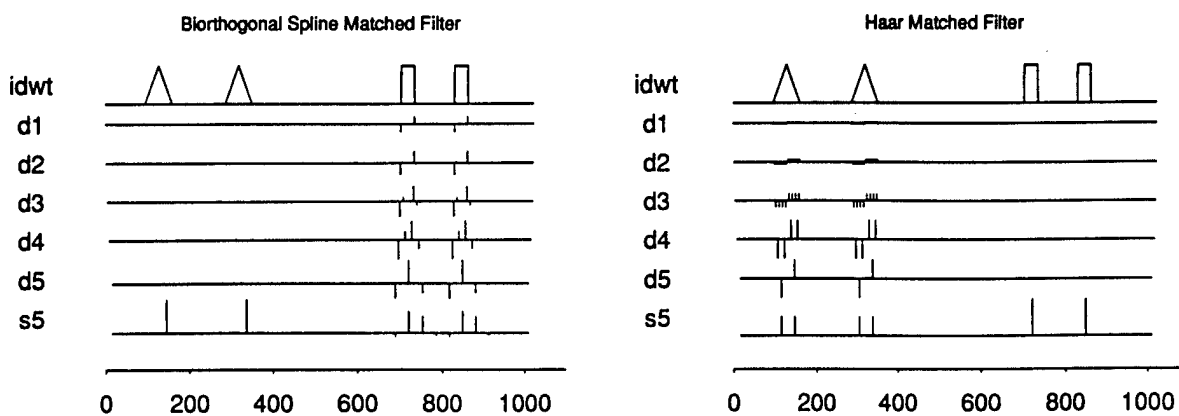
A minefield will be analyzed and is depicted in Figure 4. A wavelet decomposition and segmentation is shown of an individual mine in Figure 5. The edges are readily apparent. To determine if a match exists with some probability we need a statistic to conclude whether the characteristics of the template (i.e. the individual mine) and segments of the image correspond. A probability measure is developed by first defining distributions of the template and objects in the image with

$$P_T(i,j) = \frac{T(i,j)}{\sum_{i,j} T(i,j)},$$

$$P_O(i,j) = \frac{O(i,j)}{\sum_{i,j} O(i,j)}. \quad (14)$$



**Figure 2** Signal Recovery from noise using threshold values determined in the wavelet domain. The signal is then reconstructed into the time domain.



**Figure 3** Wavelet transform of a combination signal of ramp and step functions using matched wavelet analysing functions

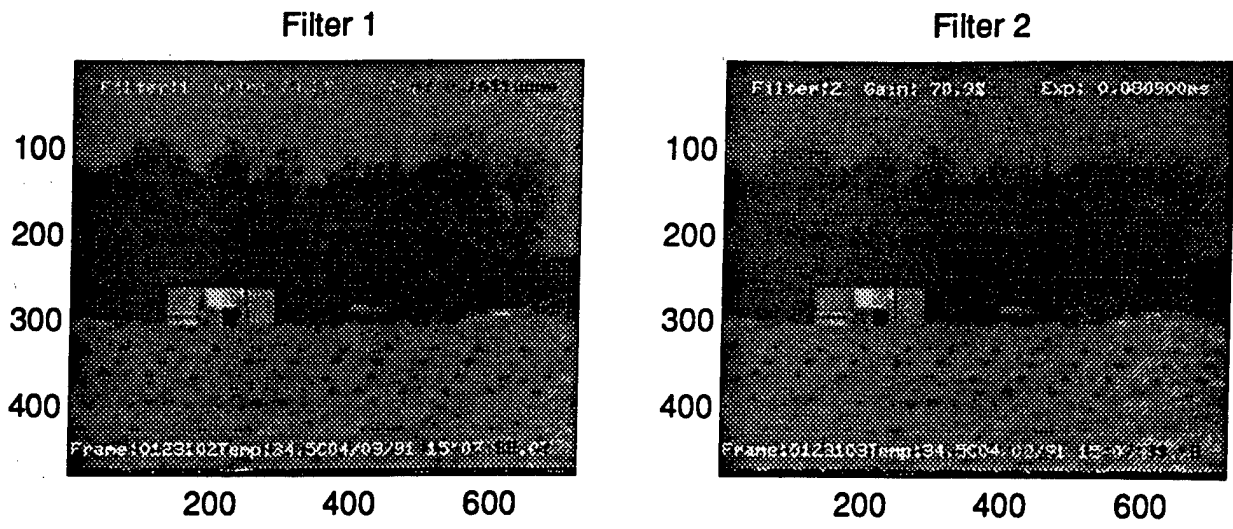


Figure 4 Minefield imaged off the coast of Florida using two different IR filters.

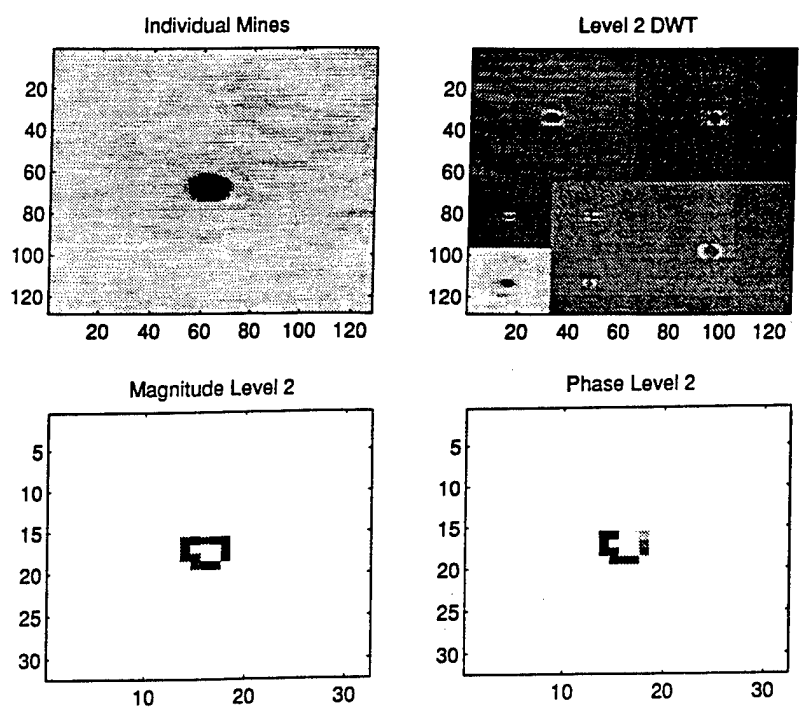


Figure 5 Mine edges for an individual mine identified using a wavelet decomposition at level 2

These are the probability densities for the object and the template. It is assumed that the object or template has been transformed and scaled into the appropriate coordinated system for comparison. Simple interpolations have been applied for points not on this equally spaced grid. The hypothesis test to determine if there is a correspondence of the distributions is

$$H_0: P_T(i,j) = P_O(i,j) \quad \forall i,j \quad (15)$$

which leads to a maximum likelihood estimator of

$$P(i,j) = \frac{O(i,j) + T(i,j)}{\sum_{i,j} (O(i,j) + T(i,j))} \quad (16)$$

Then the chi-squared statistic for this assumption becomes

$$\sum_{i,j} \frac{(O(i,j) - P(i,j) \sum_{i,j} O(i,j))^2}{P(i,j) \sum_{i,j} O(i,j)} + \sum_{i,j} \frac{(T(i,j) - P(i,j) \sum_{i,j} T(i,j))^2}{P(i,j) \sum_{i,j} T(i,j)} \quad (17)$$

which is distributed as

$$\lim_{\sum_{i,j} \rightarrow \infty} \xrightarrow{d} \chi^2_{\sum_{i,j} - 1} \quad (18)$$

where the  $\sum_{i,j}$  are the number of pixels in the distribution.

Now that we have the probability measure we can take the minefield previously depicted and determine where the mines are located. Figure 6 shows that there are significant areas where mines are located. Taking this same section of the minefield and adding noise determines how robust this measure would be to locating areas if the image were degraded.

Figure 7 gives the results of this degradation. As more noise is added the probability of locating the mines decreases. An empirical distribution was created as the Peak Signal to Noise Ratio (PSNR) was decreased. Since there were 256 pixels in the image, we can see that degradation occurs at around 20db PSNR. Naturally we can compensate for this increase in noise but our ability to distinguish edges will start to be diminished as well.

### III CONCLUSION

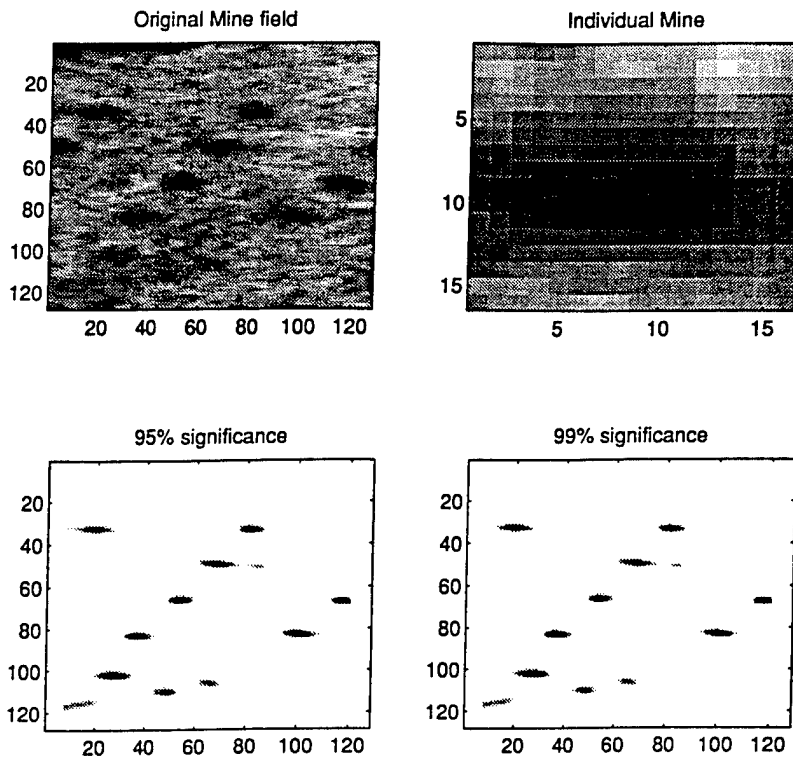
Wavelets are a convenient way to analyze signals of the time domain. Continuously sampled signals can be envelope detected in the wavelet domain and transformed

back to the time domain. The probabilities of false alarm and detection are easily calculable. By utilizing the appropriate wavelets, and or its components, it is also possible to identify the type of signal being detected.

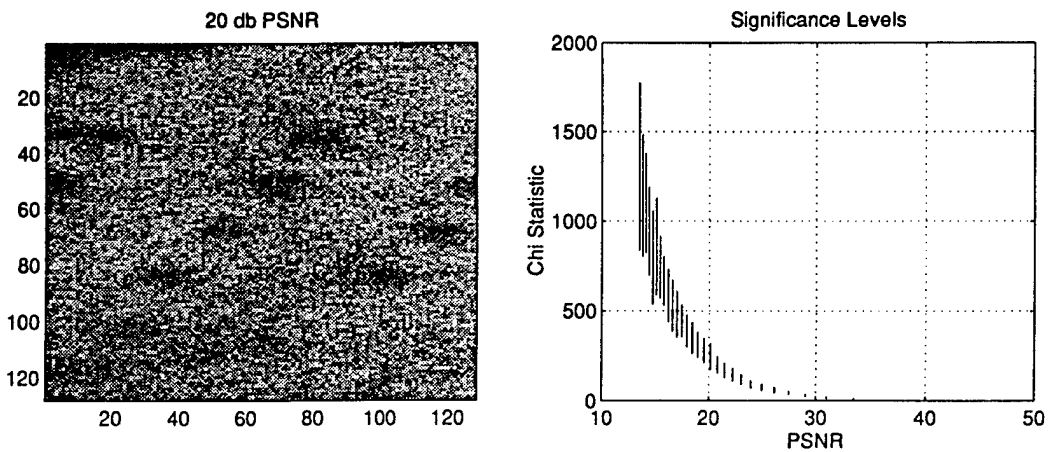
The usefulness of wavelets for image analysis lies in their ability to determine the boundaries or edges of objects. Due to the multiresolution analysis aspects, edges can be determined at sparse levels in the wavelet matrix requiring less computational loading to determine a correspondance between the template and image.

### ACKNOWLEDGMENTS

This research was supported by ONR N00014-92-J-1086 and N000014-93-1-0892.



**Figure 6** Probable areas where mines are located in this segment of the minefield image.



**Figure 7** Degradation of the image leads to a reduction in the Probability of Detection

## REFERENCES

- Anderson, T. W., *An Introduction to Multivariate Statistical Analysis*, John Wiley and Sons, Inc., New York, 1958.
- Akansu, Ali N. and Richard A. Haddad. *Multiresolution Signal Decomposition: Transforms, Subbands, and Wavelets*, Academic Press, pp 101-110, 1992
- Brockwell, Peter J. and Richard A. Davis. *Time Series: Theory and Methods*, Springer-Verlag, second edition, pp 78, 83, 123, 1991
- Bruce, Andrew and Hong-Ye Gao, *S+Wavelets: User's Manual*, Mathsoft Inc., pp 33-34, 1994.
- Canny, J., A computational approach to edge detection, *IEEE Trans. Patt. Anal. And Mach. Intell.*, vol. 36, pp. 961-1005, Sept. 1986.
- Curtis, J.H., *A Note on the Theory of Moment Generating Functions*, *Ann Math. Stat.*, pages 430-433, 1942.
- Daubechie, Ingrid., Ten lectures on wavelets, *Society for industrial and applied mathematics*, Philadelphia, PA, 1992.
- Donoho, David L. and Iain M. Johnstone, and Gerard Kerkyacharian and Dominique K. Picard, Wavelet Shrinkage: Asymptopia, *JRSS B*, 57, 2, 1995
- Hayes, Monson H., *Statistical Digital Signal Processing and Modeling*, John Wiley and Sons, page 12, 1996.
- Hoel, Paul G. and Sidney C. Port and Charles J. Stone, *Introduction to Probability Theory*, Houghton Mifflin Company, pages 200, 205, 1971
- Hogg, Robert V. and Allen T. Craig. *Introduction to Mathematical Statistics*, Macmillan Publishing Co., Inc, pp 405-419, fourth edition, 1978
- Lehr, Mark E. and Keh-Shin Lii, Template Basis Techniques to Pattern Recognition, *SPIE Proceedings*, vol 2825, pp 972-981, Aug 1996.
- Mallat, Stephane., A theory for multiresolution signal decomposition: the wavelet representation., *IEEE Transactions on Pattern Analysis and Machine Intelligence*, 11(7):674-693, 1989.
- Mallat, Stephane, Wavelets for a Vision. *Proceedings of the IEEE*, vol. 84, no. 4, April 1996.
- Press, William H., and Saul A. Teukolsky and William T. Vetterling and Brian P. Flannery, *Numerical Recipes in C*, second edition, Cambridge University Press, Cambridge, 1992.
- Rohatgi, V. K., *An Introduction to Probability Theory and Mathematical Statistics*, John Wiley and Sons, pages 95-96, 1976.
- Skolnik, Merrill., *Introduction to Radar System Analysis*, McGraw Hill, second edition, 1980.
- Vetterli, Martin and Jelena Kovacevic, *Wavelets and Subband Coding*, Prentice Hall, page 127, 1995.
- Wider, D. V., *Advanced Calculus*, second edition, page 460, 1961.

APPENDIX

Distributional Aspects of Various Transformed Signals

**Definition A.1** The characteristic function of a random variable  $X$  is defined as

$$\phi_X(t) = E(e^{itX}).$$

Where the operator  $E(*)$  is the expectation of  $X$  defined by

$$E(e^{itx}) = \int e^{itx} f(x) dx$$

and  $f(x)$  represents the probability density function of the random variable. (Hoel et al., 1971)

**Theorem A.1** The characteristic function of a random variable (r.v.)  $X$  exists for every distribution. Moreover, it uniquely determines the distribution of the random variable. Refer to (Rohatgi, 1976) for the statement and (Widder, 1961), and (Curtis, 1942) for the proof.

**Proposition A.1** The characteristic function of a random variable  $X$  that is normally distributed with mean  $\mu$  and variance  $\sigma^2$  is

$$\phi_X(t) = e^{it\mu - (\sigma^2 t^2)/2}.$$

The proof is the direct application of the definition of the characteristic function. (Hoel et al., 1971)

**Proposition A.2** The characteristic function of a scaled random variable  $Y = aX$  is

$$\phi_Y(t) = \phi_X(at).$$

The proof is a direct application of the definition of the characteristic function.

**Proposition A.3** The characteristic function of a random variable  $Y = X_1 + X_2 + \dots + X_n$  is

$$\phi_Y(t) = \prod_{i=1}^n \phi_{X_i}(t)$$

provided the  $X_i$  are random independent variables. The proof again is a direct application of the characteristic function definition and the product rule.

**Definition A.2** A Finite length Impulse Response (FIR) filter is an important class of linear shift invariant operations having the following form

$$\underline{Y} = H(z^{-1})\underline{X}$$

where  $\underline{X}$  represents the input vector,  $H(z^{-1})$  is the filter coefficient polynomial, and  $\underline{Y}$  is the output vector. The filter coefficient polynomial has the form

$$H(z^{-1}) = h_0 + h_1 z^{-1} + h_2 z^{-2} + \dots + h_q z^{-q}$$

and  $B = z^{-1}$  is the back shift operator defined by (Brockwell and Davis, 1991) as

$$B^j X_t = z^{-j} X_t = X_{t-j}$$

In component form the FIR filter satisfies the following linear equation

$$y_n = \sum_{k=0}^q h_k X_{n-k}$$

(Hayes, 1996).

**Lemma A.1** A sequence of independent random variables  $X_0, X_1, \dots, X_q$  are filtered using an FIR filter. The output  $Y$  of the filter has the following characteristic function

$$\phi_Y(t) = \prod_{k=0}^q \phi_{X_{q-k}}(h_{kt}).$$

The proof is an application of the above propositions.

**Definition A.3** Quadrature Mirror Filters (QMF) -- Let  $L(z^{-1})$  be some FIR low-pass filter with real coefficients. The high pass mirror filter  $H(z^{-1})$  is defined as  $h_k = (-1)^k h_k$  or equivalently in the transform domain as  $L(z^{-1}) = H(-z^{-1})$ . Hence, the appellation, QMF since the pole-zero patterns are reflected about the imaginary axis of the  $z$ -plane. (Akansu and Haddad, 1995)

**Definition A.4** Perfect Reconstruction (PR) -- The analysis filters for the QMF have corresponding synthesis filters which permit the reconstruction of the original signal exactly.

**Definition A.5** Multiresolution Signal Analysis -- Multiresolution refers to the filter stages applied to the input sequence. Compactly supported Wavelet bases can be constructed from a multiresolution signal analysis. Mallat and Meyer developed orthonormal wavelets of compact support which are FIR PR-QMF. (Akansu and Haddad, 1995)

**Theorem A.2** Let  $X_1, X_2, \dots, X_n$  be independently distribution gaussian random variables having different means and variances. The resultant vector  $\underline{Y}$  of a multiresolution analysis involving compactly supported

Proof  
Given

$$\underline{X} \stackrel{d}{\Rightarrow} N(\underline{\mu}, \underline{\sigma}'I\underline{\sigma})$$

Recall that the first stage of a wavelet multiresolution analysis involves high and low passed filters whose characteristic functions are

$$\phi_{d_{1,n}}(t) = \prod_{k=0}^q \phi_{X_t}(h_{2n-k}t),$$

and

$$\phi_{s_{1,n}}(t) = \prod_{k=0}^q \phi_{X_t}(l_{2n-k}t),$$

by the above Lemma. Using the definition of a characteristic function of a gaussian distribution from the above Propositions gives

$$\phi_{d_{1,n}}(t) = e^{it \sum h_k \mu_k} e^{-t^2/2 \sum (h_k \sigma_k)^2},$$

and

$$\phi_{s_{1,n}}(t) = e^{it \sum l_k \mu_k} e^{-t^2/2 \sum (l_k \sigma_k)^2}$$

which is itself gaussian. At the mth stage the characteristic functions are

$$\phi_{d_{m,n}}(t) = \prod_{k=0}^q \phi_{s_{m-1,k}}(h_{2n-k}t),$$

and

$$\phi_{s_{m,n}}(t) = \prod_{k=0}^q \phi_{s_{m-1,k}}(l_{2n-k}t).$$

This is again gaussian. Since the resultant vector is composed of successive gaussian random variables at each stage then

$$\underline{Y}_1 = \begin{bmatrix} s_1 \\ d_1 \end{bmatrix}, \quad \underline{Y}_2 = \begin{bmatrix} s_2 \\ d_2 \end{bmatrix}, \quad \dots, \quad \underline{Y}_m = \begin{bmatrix} s_m \\ d_m \\ \vdots \\ d_1 \end{bmatrix}$$

Y at any stage is itself gaussian. Q.E.D.

A multiresolution analysis is composed of compactly

supported wavelet filters, i.e. FIR PR-QMF's. This type of filter is a linear operator. In addition, the construction is such that they are orthonormal if their synthesis and analysis filters are equivalent. Therefore, we can augment our previous results by generalizing with orthonormal matrices.

**Theorem A.3**  $\underline{Y}$  is multivariate normal under an orthonormal wavelet transform  $\underline{W}$  if and only if the input vector  $\underline{X}$  is multivariate normal.

$$\underline{X} \stackrel{d}{\Rightarrow} N(\underline{\mu}, \underline{\Sigma}) \quad \wedge \quad \underline{Y} = \underline{W}\underline{X}$$

$$\Leftrightarrow \underline{Y} \stackrel{d}{\Rightarrow} N(\underline{W}\underline{\mu}, \underline{W}'\underline{\Sigma}\underline{W})$$

Orthonormality implies the transpose of  $\underline{W}$  is equivalent to the inverse. For the proof, refer to (Hogg and Craig, 1978) or (Anderson, ) which uses the concepts of characteristic functions as previously defined with matrix operations.

#### ARMA Sequence under the Wavelet Transform

Assume that an ARMA(p,q) process (Brockwell and Davis, 1991) given by

$$\phi_p(B)X_t = \theta_q(B)Z_t$$

can be rearranged into an infinite series which is convergent (i.e. an exponentially decaying process) such as

$$X_t = \phi_q^{-1}(B)\theta_q(B)Z_t, \\ X_t = \psi(B)Z_t.$$

Then the first stage output of the wavelet filter in the z domain is

$$s_1(z) = \frac{1}{2}[L(z^{1/2})X(z^{1/2}) + L(-z^{1/2})X(-z^{1/2})],$$

$$d_1(z) = \frac{1}{2}[H(z^{1/2})X(z^{1/2}) + H(-z^{1/2})X(-z^{1/2})].$$

And, the nth stage output of the filter is



$$s_n(z) = \frac{1}{2} [L(z^{1/2})s_{n-1}(z^{1/2}) + L(-z^{1/2})s_{n-1}(-z^{1/2})],$$

$$d_n(z) = \frac{1}{2} [H(z^{1/2})s_{n-1}(z^{1/2}) + H(-z^{1/2})s_{n-1}(-z^{1/2})].$$

An approximation to this can be developed with the assumption of no aliasing up to the nth stage giving

$$s_n(z) = Z(z^{2^{-n}})\psi(z^{2^{-n}})\prod_{i=1}^n L(z^{2^{-i}}),$$

$$d_n(z) = Z(z^{2^{-n}})\psi(z^{2^{-n}})H(z^{2^{-1}})\prod_{i=1}^{n-1} L(z^{2^{-i}}).$$

The spectral density of this process can be estimated assuming a white noise input sequence. This gives the following spectral density function

$$f_{s_n}(\lambda) = \frac{\sigma^2}{2\pi} |\psi(e^{-i\lambda 2^{-n}})|^2 \prod_{k=1}^n |L(e^{-i\lambda 2^{-k}})|^2,$$

$$f_{d_n}(\lambda) = \frac{\sigma^2}{2\pi} |\psi(e^{-i\lambda 2^{-n}})|^2 |H(e^{-i\lambda 2^{-1}})|^2 \prod_{k=1}^{n-1} |L(e^{-i\lambda 2^{-k}})|^2.$$

If the output process is a white noise sequence then the coefficients will be white noise as well by theorem A.2.

# Acoustic Characterization of Seagrasses and their Effects on Mine-Hunting Sonars

Elena McCarthy  
Naval Undersea Warfare Center  
Newport, RI 02841 USA

**Abstract-** The acoustic characteristics of submerged aquatic vegetation (SAV) were investigated in order to enhance the performance of mine-hunting and weapon sonars in littoral regions. The species of seagrass initially studied was *Zostera marina*. Laboratory measurements of target strength and backscatter were made in controlled conditions in an acoustic tank. Beam patterns were also generated. Experimental target strength measurements compared well to the theoretical target strength. No frequency dependence was found from 200-750 kHz. *In-situ* measurements were carried out in the shallow water eelgrass beds of Narragansett Bay with both side-scan and single beam sonars. These experiments clearly illustrated the backscatter effects of submerged aquatic vegetation in the 100-400 kHz frequency range.

## I. INTRODUCTION

The US Navy's emphasis on shallow water research dictates the need for improved range dependent sonar models and a better understanding of bottom interactions. This project was initiated after naval operations in littoral regions indicated that acoustics were often ineffective in finding mines in part due to extensive seagrass [1]. Seagrass is known to adversely affect the Navy's ability to detect mines, thus compromising shallow water mine countermeasures. In addition to physically creating problems with mine burial during mine placement, backscatter from seaweeds and seagrasses creates interference with sonars and could mask the presence of a mine during mine-hunting. Some foreign mines are designed specifically to exploit this backscatter effect.

In Tarut Bay, in the Arabian Sea, a survey of fifty locations yielded an estimate of 66% grass cover for the entire bay; i.e. 175 sq. km of seagrass coverage [2]. In the Gulf of Oman, *Sargassum aquifolium*, a seaweed, may grow to a length of about 1.50 meters and produce dense masses of plants. The leaves contain hundreds of tiny air sacs (radii from 0.02 to 0.17 cm.) and act as effective sound scatterers; their air sacs are

resonant at frequencies of 5 to 20 kHz at pressures of 2 to 5 atmospheres [3]. This may have a significant effect on many mine-hunting systems. Additionally, algal fouling can create problems for mines which have been deployed for some time (weeks to months) as they plug and interfere with the acoustic detonator. This can damp out the signals and make the mines ineffective against targets [4].

### A. Previous Work

There is no published literature on the physics of wave scattering by submersed vegetation. Overwhelmingly the literature consists of papers which investigate acoustics of marine mammals, plankton or fishes. An informal study was carried out by the Army Corps of Engineers which used acoustics to determine the presence of "nuisance species" in estuaries [5]. More recently a Russian effort attempted to develop physical models for estimation of scattering [6].

### B. Approach

The Naval Undersea Warfare Center Division, Newport, RI (NAVUNSEAWARCENDIV NEWPORT) received funding in Fiscal Year 1996 from the Deputy Assistant Secretary of the Navy (Environment and Safety) to initiate a preliminary investigation of the acoustic characteristics of submerged aquatic vegetation for environmental monitoring applications. The vegetation initially investigated was *Zostera marina*, a well-documented seagrass which was chosen because it is widely studied and abundant in the local waters of Narragansett Bay. Commonly called eelgrass, it is widely distributed in both the northern Pacific and Atlantic Oceans. It extends from the intertidal zone to the subtidal, often in extensive meadows. In clear waters it can be found in water depths as great as 15 m. [7].

The shallow water eelgrass beds of Narragansett Bay created an ideal testbed to gather experimental data. This allowed for the development of a methodology which can then be applied to other areas of strategic importance such as the Persian Gulf and the Adriatic Sea. The experience gained from studying eelgrass can be carried over to other types of submerged aquatic vegetation such as kelp and *Sargassum* which will likely have more pronounced acoustic signatures.

### C. Physiology of *Zostera marina*

Gas pockets or tubes called lacunae run the length of the plant. These lacunae are shown in Fig. 1. Any backscatter created by the plant is primarily a volume-scattering phenomena likely caused by these gas-filled lacunae.

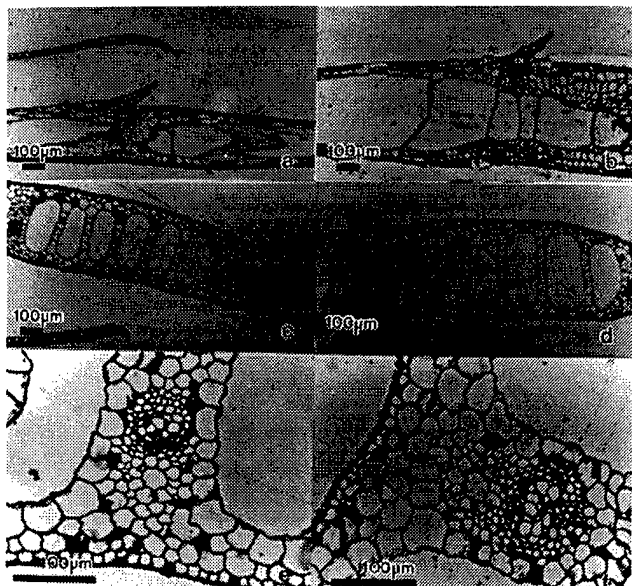


Fig. 1. Lateral cross-section of *Zostera* lacunae. The lacunae run the entire length of each blade.

## II. EXPERIMENTAL APPROACH

It was proposed to carry out acoustic measurements in controlled conditions in the laboratory to determine the fundamental acoustic characteristics of eelgrass. These experiments were carried out on a single specimen of grass in order to investigate frequency response and determine resonance. Aggregate testing was then carried out in large tanks of eelgrass (mesocosms) which provided testing of the grass as it is found in-situ but still under controlled conditions. The final component of experimentation involved field testing in Narragansett Bay using various sonars in existing eelgrass beds and ground-truth referencing by a dive team.

### A. Tank Testing

Monostatic target strength measurements were made in controlled conditions in the acoustic tank at the Naval Undersea Warfare Center in Newport. An individual blade of healthy *Zostera* approximately 30 cm in length was suspended in the acoustic tank which measures 20 meters long by 13 meters wide by 12 meters deep. The location of the grass within the tank was accurately measured. Due to the grass size and the high frequencies being used, the majority of the experiments were carried out in the near field. The reflected sound from the grass was measured and recorded at a range of frequencies from 300-750 kHz. The grass was then removed and a calibrated sphere was then positioned in the tank in the same location and

its backscatter was measured. The target strength of the eelgrass could then be determined. This was carried out at a range of frequencies in an attempt to determine frequency dependence. There is little frequency dependence found in the range of 300-750 kHz. The average target strength over this range was found to be -21 dB. This figure compares well with fish of similar size; the size of the eelgrass lacunae can be compared with the similarly-sized swim bladders of these fish. Fig. 2 shows the target strength of the eelgrass as a function of frequency.

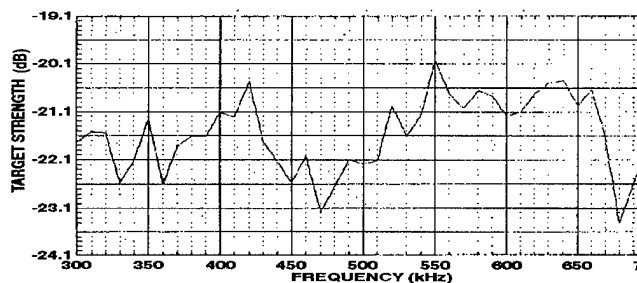


Fig. 2. Target strength of eelgrass blade as a function of frequency. These values are calculated from a 2 cycle sample FFT for rms value.

Beam pattern at a fixed frequency was also plotted during these tank tests to investigate the backscatter intensity from various angles of incidence. The blade of grass was rotated in 0.5 degree increments over a 12 hour period to cover 200 degrees. There was a strong return when the blade is insonified on its main axis (broadside) and a sharp drop-off beyond this angle. When modeled as a flat plate, the target strength values agree well with the experimental values. The results are shown in Fig. 3

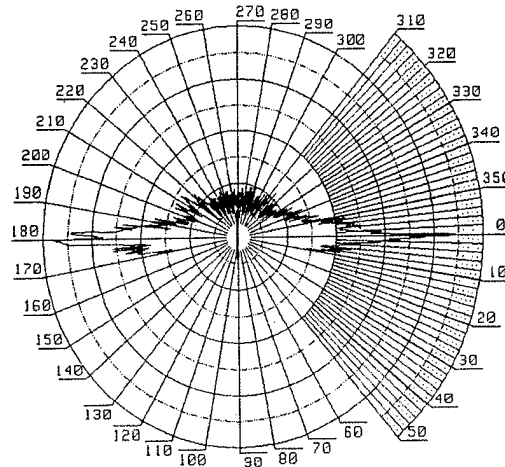


Fig. 3. Beam pattern of eelgrass blade at 400 kHz. Each division on the polar plot represents 5 dB.

### B. Mesocosm Testing

Mesocosm testing allowed for examination of grass behavior in beds as it is found *in-situ*. The experiments were carried out in the University of Rhode Island mesocosm tanks which are designed to grow communities of eelgrass for biological and ecological experiments. These tanks measure approximately 1.5m square by 1.2 meters deep and contain approximately 15 cm of sediment. The bottom of each tank is densely covered in *Zostera*. Monostatic measurements were made in increments of 50 kHz from 200-750 kHz. The backscatter measured was significant. Interestingly, the return from the actual blades of grass was could be distinguished from the the return from the bottom and a separate return that may likely originated from the rhizomes. As demonstrated earlier in the acoustic tank tests, backscatter was again pronounced throughout the frequency range but no clear frequency dependence was found.

### C. In-situ Testing

1) Single beam sonar: A single beam 420 kHz, 6 degree beam width sonar (Biosonics, Inc., Seattle, Washington) was integrated with a differential GPS to yield a digitized file of amplitudes as a function of latitude and longitude. Figure 4 illustrates the return from the eelgrass in a bed at a depth of approximately four meters. The eelgrass can be clearly seen growing up from the steep slope in the 2-4 meter water depth.

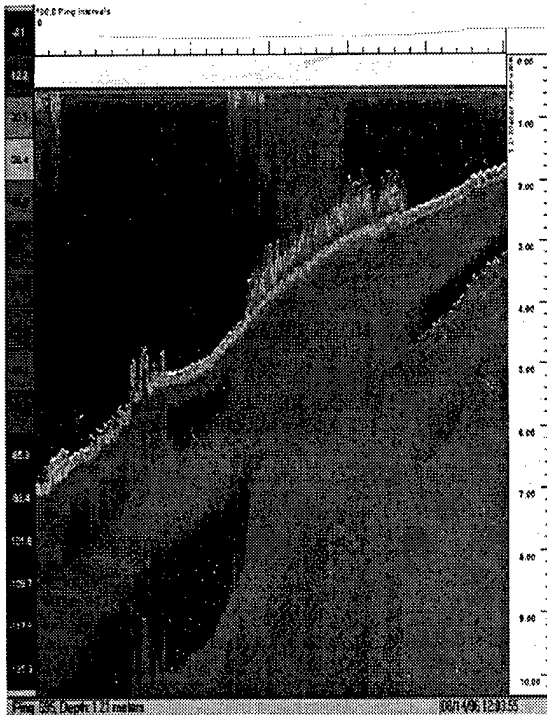


Fig. 4. Bottom return and eelgrass bed off Rose Island, Narragansett Bay, Rhode Island. Note the surface ringing and the second bottom return.

2) Side-scan sonar: An EG&G 272TD dual frequency side scan sonar was used to map known eelgrass beds in Narragansett Bay. The tow fish was deployed from a small shallow draft coastal vessel and operated at 100 kHz. Figure 5 illustrates an image from the starboard channel of the sonar. The bottom appears quite hard and well defined in the deeper water. Rocks and distinct features can be seen here. The grass bed begins to show in the 4 meter water depth. At this point, the sonar image is quite fuzzy and the grass can be seen growing up from the bottom. If a mine were located in this area, it would be acoustically masked and perhaps not detected by sonar. A dive team sampled this area and took samples from four 0.25 square meter quadrates. Sediment samples showed a sand bottom composed primarily of fine sand (54.3 %) in this area. In addition to diver observations, underwater video confirmed the presence and boundary of the eelgrass bed just as shown in this sonar image.

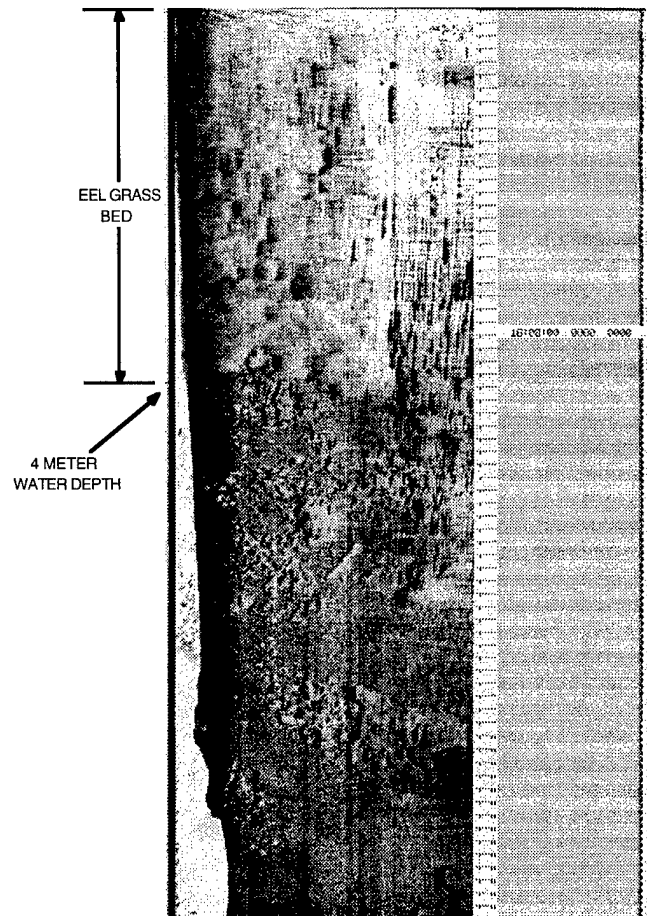


Fig. 5. The starboard trace from a side-scan sonar showing the boundary of an eelgrass bed and the backscatter it creates.

### III. MODEL DEVELOPMENT

Presently no model exists which explains the acoustic behavior of submerged aquatic vegetation. This is the first effort to gather experimental data in support of model development.

Based on the data from these experimental measurements and the fundamental physical acoustics, a model is under development for a single blade of *Zostera marina*. The model will be parameterized by frequency, depth, blade size, and orientation. An aggregate model may be required for the large beds of *Zostera* found at sea.

### IV. FUTURE WORK

Additional research would support the model development and allow for field testing with mine-like objects. Additional efforts are also required to measure target strength and backscatter from seagrasses at lower frequencies (20 - 200 kHz). In-situ experiments should be carried out with operational mine-hunting sonars to further quantify the effect of the seagrass on actual fleet hardware.

### V. DUAL USE APPLICATIONS

Eelgrass meadows are critical to the health of their ecosystem; they provide sanctuaries for many fish, reduce shoreline erosion by slowing currents, clean the water by filtering nutrients and particles, and provide food for crabs, ducks, and other marine life. Eelgrass beds are six times more productive than any other bottom cover. Other applications of this research include tracking seagrasses acoustically to monitor pollution and help biologists carry out distribution and density studies. Discussions with the Environmental Protection Agency (EPA), National Oceanic and Atmospheric Administration (NOAA), National Marine Fisheries (NMFS), and Army Corps of Engineers (among others) indicate that a reliable, cost-effective method for monitoring and locating eelgrass beds in regions of turbid water (i.e. Boston Harbor) is required. Conventional methods involving aerial photography can be difficult and expensive if water clarity is not sufficient. Physical techniques for detection and characterization are labor and cost intensive and provide little insight into spatial distribution.

This eelgrass acoustics study has been identified as a Coastal America Program which integrates the capabilities of existing resources with those of federal, state and local agencies and non-governmental concerns. It is expected that the same technology that the Navy develops to eliminate the "noise" from seagrass during mine-hunting operations will be used to locate and track seagrass for environmental projects such as the National Estuary Project.

### VI. CONCLUSIONS

Results from initial laboratory and *in-situ* testing have indicated that seagrass may adversely affect the Navy's ability to detect mines by creating backscatter or acoustic interference with mine-hunting sonars. A more thorough understanding of the acoustic properties of seaweeds and seagrasses is therefore essential for optimal performance of mine-hunting sonars in littoral regions.

Research to date has provided for experiments with side-scan sonar and conventional single beam sonars which have clearly shown the backscatter effects of submerged aquatic vegetation in the 100 - 700 kHz frequency range. No frequency dependence was found from 200-700 kHz although backscatter is significant in this region. The target strength measured approximately -21 dB. The acoustic response of a single specimen of grass was found to be largely dependent on orientation.

It is hoped that these measurements will aid in the development of methods to enhance the performance of mine-hunting and weapon sonars. The data should also supply important environmental input to range-dependent sonar models and enhance tactical and environmental databases.

### ACKNOWLEDGMENT

The author would like to thank Robert Tompkins, Dr. Bruce Sandman, Jason Gomez and Walt Boober from the Naval Undersea Warfare Center in Newport, Rhode Island. She would also like to thank Steve Granger, Sue Sherwood Dr. James Miller and Blaine Kopp from the University of Rhode Island, Ken Rocha from the Environmental Protection Agency in Narragansett, RI and Bruce Sabol from the Army Corps of Engineers, Waterways Experimental Station, Vicksburg, MS.

### REFERENCES

1. R. Alberte, Office of Naval Research, e-mail from R. Alberte to E. McCarthy, 6 June 1995.
2. Basson et al, Biotopes of the Western Arabian Gulf., Aramco Dept. of Loss Prevention and Environmental Affairs, Dhahran, Saudi Arabia, 1977.
3. Naval Research Laboratory, Report NRL/AE/7170-93-0001, May 1994.

4. R. Alberte, Office of Naval Research, e-mail from R. Alberte to E. McCarthy, 11 Oct. 1995

5. Sabol, B. and Melton, R.E. (1995). "Development of an automated system for detection and mapping of submersed aquatic vegetation with hydroacoustic and global positioning system technologies, Report I: The submersed aquatic vegetation early warning system (SAVEWS)-System description and user's guide (Version 1.0)," Joint Agency Guntersville Project Aquatic Plant Management.

6. Shenderov, E., Research and Development Institute, "Morfizpribor", St. Petersburg, Russia, unpublished.

7. Phillips, R. and Menez, E. (1988). Seagrasses, Smithsonian Institution Press, Washington, D.C.



# New Technologies for the Military: Mine Warfare as a Test Case

Joseph J. Molitoris

The Mine Warfare Association/ GRC International

6802 Silver Ann Drive

Lorton, VA 22079

PH: 703 550 8276, FX: 703 550 8276, EM: xlqm71a@prodigy.com

**Abstract**—Several new technologies are poised to rapidly affect military operations and DoD. These include: the Internet, modeling and simulation, Global Broadcast Service, personal communications services, unmanned vehicles, fully or partially remotely operated ships or planes, and smart platforms with reduced manning. I focus on a few of these technologies in detail. Some of the questions addressed include the following. What is the technology now? How does the system(s) differ from what is used in the commercial world? What technological limitations must be overcome for it to be operationally effective in the near term? What will the technology be tomorrow? What cultural and doctrinal changes are needed for it to be an effective DoD system in the long term? These are just some of the important questions about emerging technologies which the analytical, acquisition, and operational communities are considering.

## I. BOTTOM LINE

Advanced modeling and simulation is of growing utility for the military. Potential uses are for mission support, situational awareness displays, rehearsal and replay, analysis, assessment, doctrine, tactics, and training. UUVs, AUVs, and other new technology platforms (e.g. Arsenal Ship, CVX, SC-21, Smart Ship) can be assessed using appropriate levels of simulation. New sensors (sonars, lasers, gradiometers) and systems (mechanical sweeps, influence sweeps, distributed explosive technology) can be evaluated. The battle or simulation manager (SM) is the flexible piece of software that commands, controls, and displays the simulation of a group of objects. It is an environment or toolkit for analysis, assessment, training, and wargaming. Current doctrine and tactics can be tested and missions or campaigns planned with this kind of software. The military platforms (objects) propagate and interact in space over the course of time. Some of the difficulties with the current generation of software can be fixed with a better product that makes use of object oriented technology: design, programming, databases, and parallel processing. It is possible that such a product will be soon available since several next generation codes are being built by the government, laboratories, academics, and companies.

Advanced modeling and simulation is but one part of a potential object oriented infrastructure that could be available to DoD in the long term. The Internet and various

high data rate transfer methods such as DBS are enablers for this user-centric infrastructure.

Direct broadcast satellite (DBS: the consumer market small 18" dish and set-top box) has evolved to a possible joint DoD system for cheap (\$200 per COTS system) high data rate (23 Mbps) military bits (voice, video, data, imagery, etc.) transmission. GBS differs from DBS in several ways because of military specific requirements. The envisioned military operational use of the system nevertheless provides a potential factor of over 1000 improvement in tactical data rate capability (10 kbps to 23 Mbps) with respect to current systems. The impact of GBS technology combined with Asynchronous Transfer Mode (high capacity) or Internet Protocol networking and new encryption devices is thus a topic of great interest.

In its simplest form, the GBS system transmits military video to any desired component of command: buildings, ships, the foxhole. More sophisticated GBS systems involve the transmission of data files (ATOs, imagery, messages, etc.) up to hundreds of MegaBytes in size. Commercial market factors, JWID 95 (Joint Warrior Interoperability Demonstration), JWID 96, and other exercises/operations enable considerable insight into what the GBS system might become. There have been defined measures of effectiveness and extracted a number of lessons learned about how the current testbed GBS systems operate. These lessons relate directly to what will be possible for a near term GBS system (GBS in Bosnia and GBS on UFO 8, 9, and 10) and shed light on potential requirements for longer term systems.

The views expressed herein are solely those of the author and should not be attributed to any company, association, government, or military agency.

## II. DBS

The DBS system [1] consists of:

- Set-top box
- 18 inch satellite receive dish
- Remote control unit.

Several vendors offer variants of the system, uplink site, and satellite downlink but the system demarcation criterion is cheap (\$200 for the COTS version) high data rate (23 Mbps or millions of bits per second) communications.



DBS is a mass market system with strong sales [2]. Fig. 1 gives example sales figures for January through August of 1995. Sales for this period averaged 54,000 units per month with a standard deviation of 16,000 units. In the first year of sales, 650,000 units were sold, making this the fastest selling new electronic product ever introduced [2] – faster than the VCR which sold about 250,000 units in its first year. The DBS market is still quite explosive. Recently, AT&T joined the Hughes DBS venture on the distribution side for 138 M\$ [3] and MCI bought the last license for DBS at 682 M\$ [4].

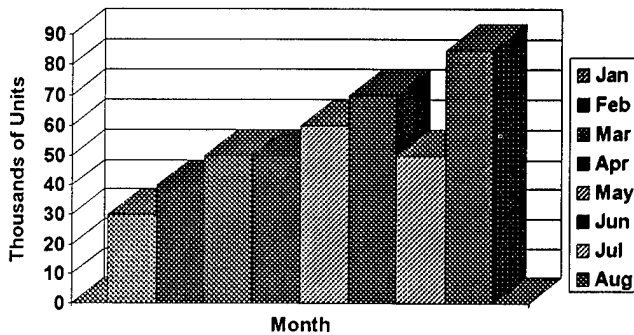


Fig. 1. Sample DBS sales in 1995.

The price of the DBS system has fallen dramatically over the past year, from the \$700-1000 price range to \$200-400, depending on the supplier. This is part of the benefit of using an emerging mass market device: the cost is not only affordable, but can even go down.

### III. COMMERCIAL MARKET

The earth station market [5,6] has been fairly stable since 1990 as seen in Fig. 2. There is about 400 M\$ of sales annually.

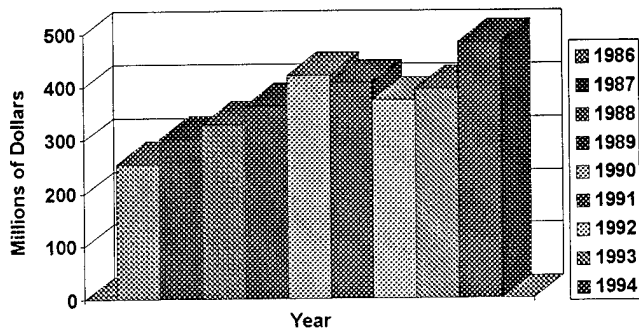


Fig. 2. Earth station sales.

The number of direct to home TV users (see Fig. 3) has been rising rapidly and thus there is a competition with the more mature cable market for the 62 million available users [6]. There are currently about 4.6 million direct to home TV users [7]. The cable market only grows with a 2.5% CAGR, whereas the newer direct to home TV market is growing at a 43% rate. As a reference point, note that annual population growth for the U.S. tends to be about 1.0%.

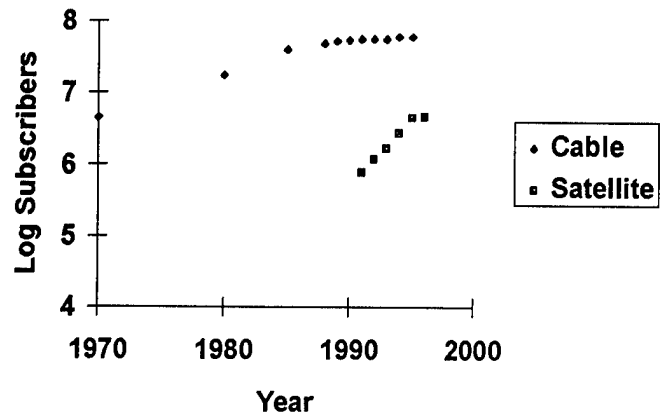


Fig. 3. Cable and direct to home satellite TV users.

Data transmission is not new. Video transmission is not new. What is new and exciting about DBS (and other technologies like VSAT) is cheap high data rate transmission for the individual user.

### IV. GBS TODAY

Early high level support has helped to make the GBS system a potential success in acquisition reform and technology insertion. VADM Jerry Tuttle has said: "It's the wave of the future [8]." VADM Walter Davis has commented: "We have tried that out and it works like a charm [9]."

Navy TENCAP has been a prime mover in making GBS a reality through demonstrations, exercises, and operational support [10,11].

The current GBS system uses a larger 1 meter dish (at \$300 cost) in order to access leased transponders from satellites such as the Telstar 401 and Orion 1. A Sun workstation with some peripheral hardware is used to process the data (\$20,000 cost). Special encryption equipment is also required depending on the desired level of classification. Other costs include the leased satellite time (\$600-1000 per hour) and special installation (mounting and stabilization) for mobile platforms (in excess of \$30,000 according to [12]).

Here is seen one of the potential dangers to a GBS program: costs can quickly escalate (on a per site basis) with the addition of ATM switches (\$50,000-100,000) and special servers (\$200,000-300,000). One needs to keep it cheap and keep it simple for the system to be deployed widely.

The best baseline picture of the GBS system today comes from its documented use in JWID 95 and other demonstrations and exercises [13-17]. Fig. 4 shows the conceptual architecture for GBS use. So long as the cost of a GBS installation is kept cheap, it can go to *all* platforms.

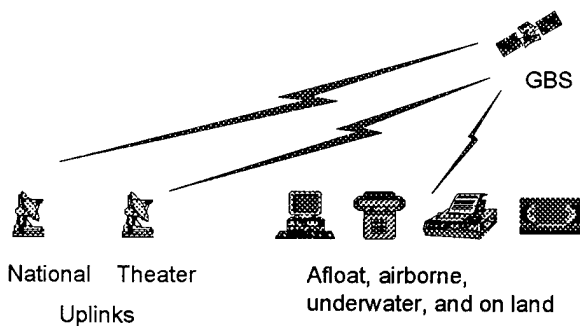


Fig. 4. Conceptual GBS information flow.

The GBS system transmits one or more video channels, a stream data channel, an Internet Protocol data channel, and an ATM data channel to several remote sites.

### V. GBS MOPS

In this paper, we mention two simple measures of performance (MOP) that have been used to baseline the performance of the GBS system [16]:

- Number of files transferred
- Number of MB transferred.

Many other issues related to the performance of the GBS system have been discussed in detail elsewhere [16].

### VI. GBS IN JWID 95,96 and Bosnia

The details of how the GBS system performed in JWID 95 and JWID 96 can be found elsewhere. Here, we mainly note that only a small percent of the data transmission capability was used. GBS provides a large pipe for the military to begin to fill with useful information for the warfighter.

GBS has been deployed in Operation Joint Endeavor in Bosnia [18,19] using the Orion satellite [20]. Based on lessons learned in JWID 95 [13-17], the system is here being used as a demonstration or prototype to support the peacekeeping operation.

### VII. GBS ON UFO

UFO stands for the UHF follow-on satellites. The UFO series is part of the current military satellite communications strategy to bring greater bandwidth to the warfighter [21,22].

One vision of the GBS on UFO system provides (per satellite):

- Four transponders
- Three spot beams
- One broad beam.

The system will not provide full earth coverage, but provides an interim GBS capability for DoD operational use.

Since GBS will go on UFO 8,9, and 10 in the 1997-98 time frame, total DoD satellite communication capacity could increase by 276 Mbps beyond the current baseline of 400 Mbps.

### VIII. DBS AND GBS FUTURE SYSTEMS

What will DBS be tomorrow? What will GBS be tomorrow? How many users will these systems have at home, at work, and in the military? Along with the video or TV market, the home/business/military data market will determine the future of the system [23]. The recently announced \$1000 and 25 lb GBS laptop unit holds great promise for land mobile units [24] as does phased array technology [25] with its projected cost of only \$65,000 per platform without the need for gyro-stabilization.

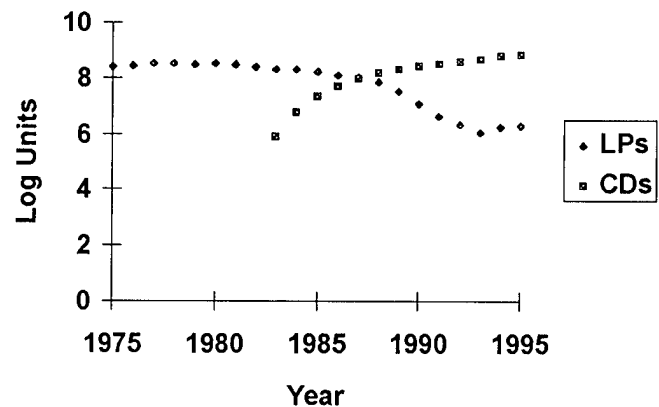


Fig. 5. CD and LP competition.

Several competing technologies are of historical interest, for example the CD and LP competition of the 1980's [6,26] shown in Fig. 5.

Other new technology competitions are occurring right before our eyes: AOL versus Prodigy, digital vs. film based cameras, Netscape vs. the MS Network Explorer, Relational vs. Object Oriented Database Management Systems, etc.

Will the DBS technology outpace that of cable in the 1990's as the CD outpaced the LP in the 1980's? What about emerging alternative technologies for land bases such as ADSL? Will GBS become the routine way of getting information (audio, imagery, messages, video, etc.) to our troops? There is no way to know for sure.

The GBS objective system still requires considerable definition. One vision sees this system as providing (per satellite):

- Twelve transponders
- Seven spot beams
- One broad beam
- Full earth coverage.

If funded, this system would provide 276 Mbps capacity per satellite!

### IX. MODELING AND SIMULATION

The DBS/GBS/JBS system was designed for video and has been adapted for data transfer use by commercial vendors and the government. Another emerging technology which may work well with the GBS system is advanced modeling and simulation.

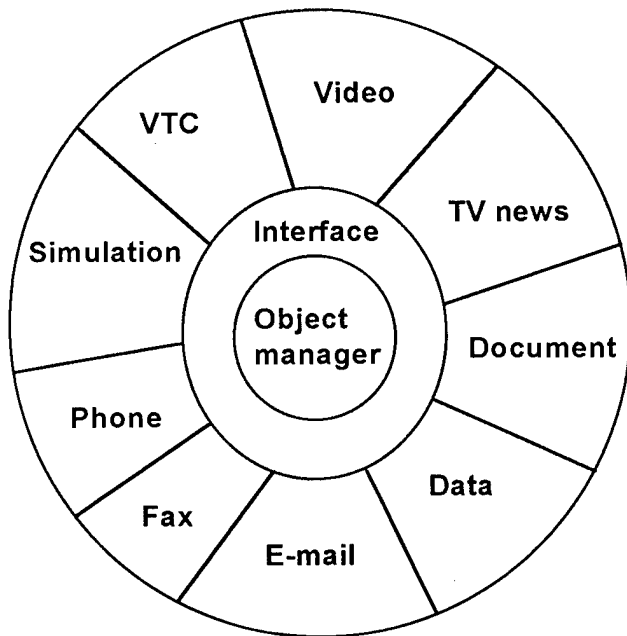


Fig. 6. Object Oriented Infrastructure.

Advanced modeling and simulation has several parts:

- Visualization and multimedia
- Object oriented technology
- Variable fidelity standard databases and models
- Distributed and parallel computing
- Knowledge based systems (AI).

Not all of these are present in any particular model or simulation, but together these parts are helping advance modeling and simulation for analytic, acquisition, and operational use [27].

The GBS system is a natural way to provide visualization, multimedia products, models, databases, and software to remote sites. This evolving synergy between C4I and modeling and simulation can be very useful to the warrior, perhaps helping to bring him the object oriented infrastructure (Fig. 6) that is sorely needed. Easy to use and familiar interfaces such as the WWW browsers can enable rapid interaction for the user with both legacy and new systems.

### X. SOFTWARE AND HARDWARE

We live in an age of rapid software development and rapid hardware evolution. Moore's law and Joy's law have tracked the growth of computer chip memory capacity and computer processor speed for decades. The computer is now a throw-away device. Once you buy it, the machine is obsolete. After two or three years, you need to buy a new one. The network end device promises to bring the cost of a computer down to the few hundred dollar range. Internet and WWW growth continue unabated.

One topic that deserves special mention is that of the Java programming language [28]. Java was developed by Sun initially for use in common appliances like toasters. Since that market was not yet mature, Java was turned into a PC, Intranet, and Internet enabler.

Java gives us the following tools we don't already have:

- C/C++ compiler with graphics
- Network capability
- Ease of software use
- Cross platform capability.

Further, Java is currently cheap: less than \$100 to get Java plus an application development environment such as Symantec Café.

Yes, Java is not perfect and some bugs and security flaws have been uncovered. However, PCs and even the venerable UNIX box have flaws too. Surely, you have seen an advanced modeling and simulation computer program crash on some UNIX machine (Sun, SGI, whatever). In time, the low cost and high capability of the Java Virtual Machine may produce huge software savings for DoD and other users.

## XI. CONCLUSION

GBS is an excellent example of an emerging technology that DoD is trying to leverage for military use [29]. It is a step on the road to our high bandwidth digital future [30] where Gbps (giga or billions of bits per second) are normal data transfer rates (Fig. 7). Advanced modeling and simulation and Java are other good examples.

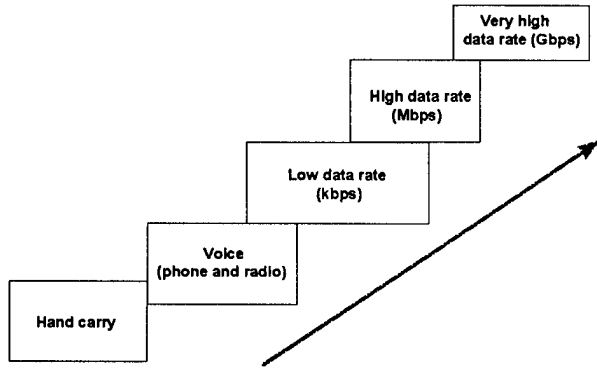


Fig. 7. Information Transfer Evolution.

## REFERENCES

- [1] "DBS: The Changing Face of TV," *Popular Electronics*, Jan. 1996, page 9.
- [2] P. Farhi, "Satellite TV Firms Shift Price," *Washington Post*, 6 Sep. 1995, page G1.
- [3] "AT&T's New Direction," *Washington Technology*, 8 Feb. 1996, page 22.
- [4] "MCI Becomes a Broadcaster," *Washington Post*, 26 Jan. 1996, page A1.
- [5] Electronic Market Data Book, Arlington(VA): Electronic Industries Association, 1995.
- [6] Statistical Abstract of the U.S., Washington(D.C.): U.S. Bureau of the Census, 1995.
- [7] Satellite Broadcasting and Communications Association, 1996.
- [8] "DBS May Boost Navy Data Relay," *Defense News*, 6 Feb. 1995, page 4.
- [9] "Navy Considers DBS," *Space News*, 6 Feb. 1995, page 10.
- [10] CDR D. Baciocco, "Direct Broadcast Satellites," *Signal*, Alexandria(VA): AFCEA, 1995, page 30.
- [11] CDR D. Baciocco, "DirecTV at Sea," *Space Tracks*, Summer 1995, page 10.
- [12] "DBS System Cost Summary," *Navy SATCOM Newsletter*, vol. 2, no. 4, Virginia Beach(VA): IST Inc., 1995, page 2.
- [13] CDR D. Baciocco, G. Braun, M. Robinson, and M. Wojcik, *Global Broadcast Service for JWID 1995 Concept of Operations*, McLean(VA): MITRE, 1995.
- [14] J. Morris, *Pre-BADD ACTD Final Report*, McLean(VA): Booz-Allen&Hamilton, 1995.
- [15] LT COL Pat Wills and Kirk Johnson, *JWID 95 Demonstration Report*, Ft. Huachuca(AZ): DISA JITC, 1995, page CN-14.
- [16] J. Molitoris, H. Nguyen, and D. Blake, *JWID 95 Global Broadcast Service Demonstration Assessment*, CRM 215, Alexandria(VA): CNA, Jan. 1996.
- [17] J. Molitoris, H. Nguyen, and D. Blake, *Global Broadcast Service JWID 1995 Test Plan*, CIM 430, Alexandria(VA): CNA, Sep. 1995.
- [18] "Bosnia Support Nets to get Upgrade," *Federal Computer Week*, Feb. 5, 1996, pages 20 and 22.
- [19] "Taste of Direct Broadcast Satellite Capabilities," *C4I News*, vol. 4, no. 7, Potomac(MD): Phillips Business Information, 1996, page 4.
- [20] *Orion Atlantic L.P., The 1995 World Satellite Almanac*, Potomac(MD): Phillips Business Information, 1995.
- [21] "Time is Money in Navy's GBS Effort," *C4I News*, vol. 3, no. 25, Potomac(MD): Phillips Business Information, 1995, page 5.
- [22] "UHF Follow-On GBS," *Hughes Space and Communications*, 1995.
- [23] "Microsoft, DirecTV Plan Satellite Networks for PCs," *Infoworld*, Mar. 25, 1996, page 50.
- [24] "Portable Earth Station," *C4I News*, vol. 4, no. 10, Potomac(MD): Phillips Business Information, 1996, page 6.
- [25] "Communication for the Mobile User," Boeing Defense and Space Group, Seattle(WA): Boeing, 1996.
- [26] Recording Industry Association of America, 1995.
- [27] J. Molitoris, H. Pham, and T. Taylor, *Battle Managers and Advanced Military Simulation*, CRM 90, Alexandria(VA): CNA, Sep. 1995.
- [28] A. van Hoff, S. Shaio, and O. Starbuck, *Hooked on Java*, NY: Addison-Wesley, 1996.
- [29] "Pentagon to Move Fast on DBS," *C4I News*, vol. 3, no. 19, Potomac(MD): Phillips Business Information, 1995, page 1.
- [30] N. Negroponte, *Being Digital*, NY: Knopf, 1995.

## A NEW DIMENSION IN AMPHIBIOUS WARFARE

By Dennis M. Verzera, LtCol, USMC

Throughout history, there have been advances in technology that have literally redefined the conduct of war. Imagine the impact on the battlefield of the first metal sword clashing upon stone and wood or mounted calvary and chariot flanking the infantry of a less sophisticated opponent. Major technological breakthroughs of such magnitude are rare. For the most part, technology is an evolutionary process which allows us to go higher, faster, farther, deeper; or see and fire upon the enemy at greater distances. Our tendency is to apply new technologies in the context of existing tactics. Our capability is enhanced, but the manner in which it is applied remains the same.

Occasionally, when we do apply new technologies "differently", the results can be equally as spectacular as a major technological breakthrough. At the onset of World War (WW) II, German systems were not significantly superior to the French or British. While the Allies used their systems in the context of WW I defensive tactics, the German Blitzkrieg literally ran around and through them. No single technological advancement was responsible for this success. The "application" of assets resulted in greater mobility, firepower, and tactical surprise. Landing Craft, Air Cushion (LCAC) offers a similar potential seaward of the high watermark.

Often, time is needed to "digest" technological innovation before we realize how to maximize the tactical application. When the LCAC was designed as a rapid waterborne hauler of equipment, we only developed a fraction of its tactical potential. LCAC provides the capability to rapidly come from over the horizon and land on a broader cross section of beaches; but, between well deck departure and the beach, the precepts of maneuver warfare are put on hold. Once we commit to a beach, our "waterborne" amphibious tactics are only marginally different from those employed during WW II.

**By actively employing our combat systems "onboard" LCAC during the initial assault, we can significantly enhance the assault force's firepower, mobility, and maneuverability.** The art of maneuver warfare can now be applied seamlessly across the entire battlefield, from deep water "through" the beach. Applications include: direct/indirect fire, logistical support, and special operations. The potential is available in the near term with minimal cost and without a significant increase in footprint.

Two basic approaches to the concept have merit.

APPROVED FOR PUBLIC RELEASE;  
DISTRIBUTION IS UNLIMITED

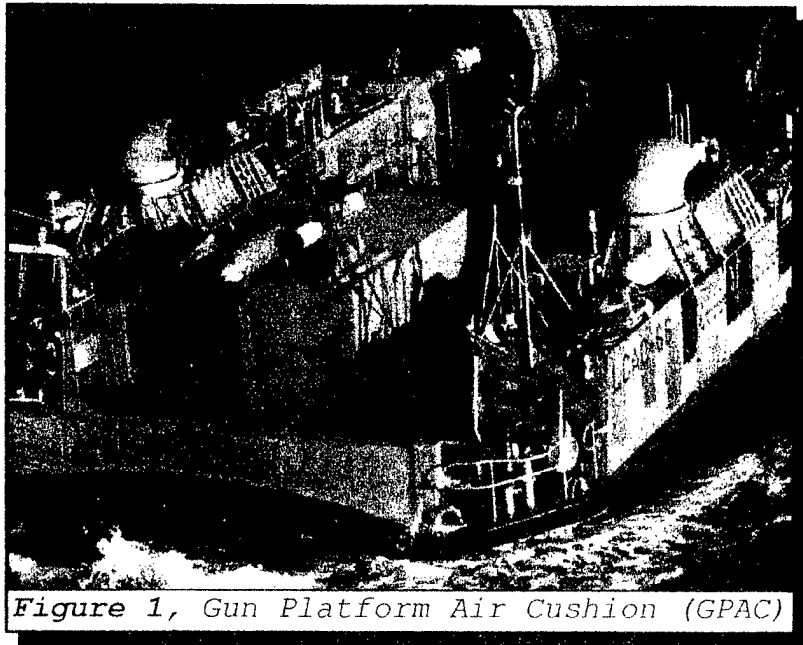
7-220

*The appearance of trade names in this document does not constitute endorsement by the Department of Defense; the Navy; or the Coastal Systems Station Dahlgren Division, Naval Surface Warfare Center.*

- Develop LCAC pack out kits which would be prestaged and flown into the theater as required. Packouts would be composed of existing LCAC compatible systems configured for a variety of requirements; such as, direct fire, indirect fire, or logistical support.

- Directly employ the Amphibious Task Force (ATF) organic systems "onboard" the LCAC during the initial assault or in follow-on missions as required.

Both approaches take into consideration the limited space aboard amphibious shipping. Each would also allow for rapid reconfiguration of the craft based upon the mission and, by using existing systems, would require minimal development time and cost.

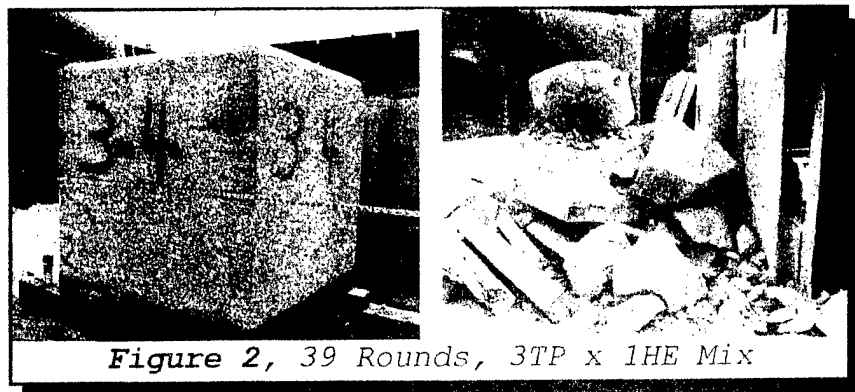


*Figure 1, Gun Platform Air Cushion (GPAC)*

#### GUN PACKOUT PROTOTYPE

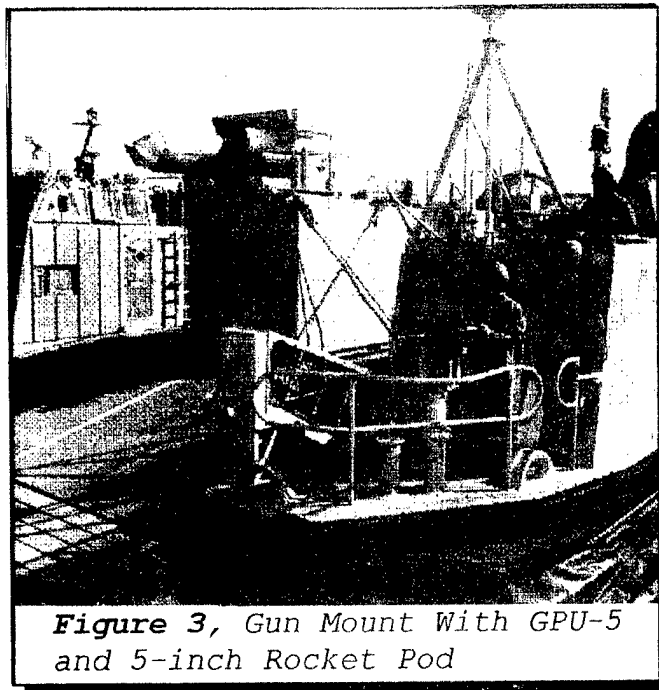
The prototype in figure 1 depicts an example of the first approach; a "fly in" direct fire weapon packout kit. The weapon is an Air Force 30mm gatling gun, the GAU 13, self-contained in the GPU 5 pod. The gun was originally designed to mount under fixed wing aircraft and be employed in antitank and close air support missions. The package (weapon system, ammunition, fire control, and rack) is housed in a standard 8- by 8- by 20-foot conex box. Following an air lift to the theater of operations, the package would be rapidly assembled and strapped directly on the LCAC or mounted on a vehicle for roll-on, roll-off capability.

The prototype was built to evaluate the GAU-13's 30mm round effectiveness against hardened beach obstacles. Preliminary results were positive. Four-foot concrete cubes, jersey barriers, and hedgehogs were destroyed in a matter of seconds. However, it was readily apparent that there was a far greater potential in employing the weapon for direct fire support during an amphibious operation. The speed and mobility of the LCAC, coupled with the firepower of the GAU 13, are potent combinations. As a platform, the LCAC offers some significant advantages to aircraft: greater payload, time on station, and an instride reload capability.



*Figure 2, 39 Rounds, 3TP x 1HE Mix*

The LCAC could support two packout kits mounted forward for a total of four 30mm guns. An additional kit could be mounted pointing to the stern for protection during egress. The weapon racks used were MAU-12, standard aircraft wing mounts, which theoretically implies that any weapon system which can be mounted on an aircraft could potentially be employed off an LCAC. The system in figure 3 is configured with a five inch rocket pod, MK19, and M2HB 50 cal machine gun. The



*Figure 3, Gun Mount With GPU-5 and 5-inch Rocket Pod*

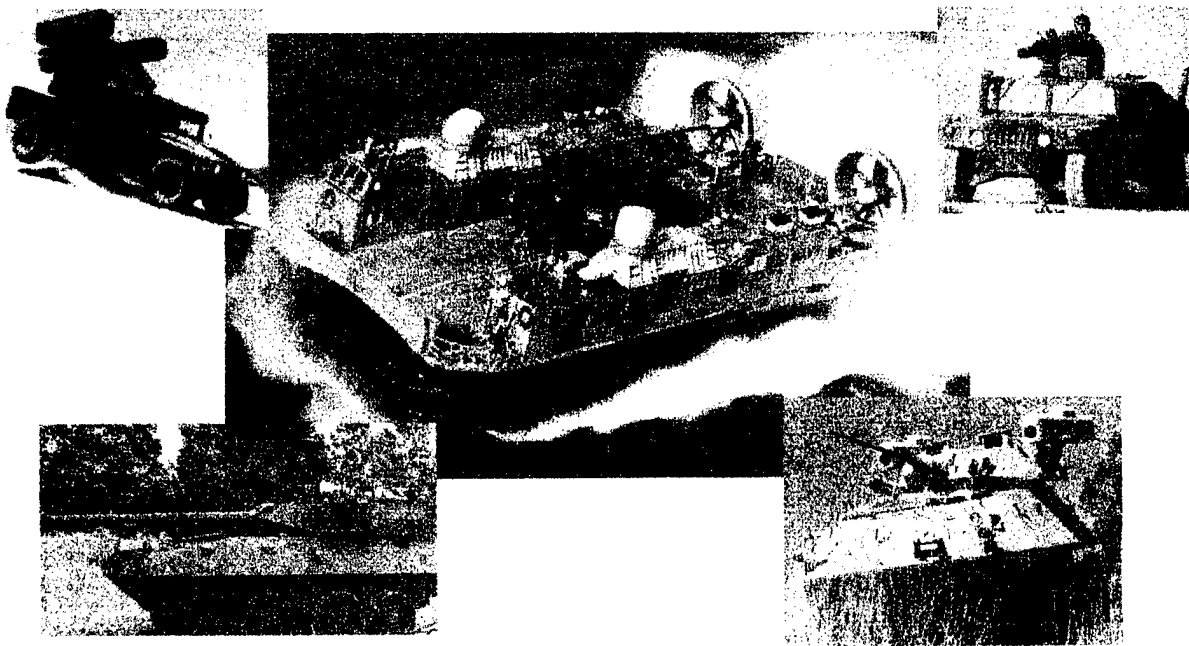
C130 gunship's 105 and low recoil 155 under development are two additional aircraft systems which merit evaluation for potential employment aboard LCAC.

Although additional testing is required, the potential is obvious. Of more importance is the concept, there are "existing" **weapon systems** which can be employed onboard LCAC that will **enhance combat capability**, and aircraft systems seem particularly

adaptable.

Although the aircraft systems show significant potential, they must be either flown in or occupy critical space onboard ship. The second approach mitigates the problem by using systems already organic to the ATF. A number of systems have potential application in a variety of roles. Ideally, the weapons selected would be organic to the ATF, have a day/night fire control system, and roll on/roll off capability. They would be employed as a waterborne maneuver element during the initial phases of the assault and immediately proceed ashore to continue support of the land battle "through" the beach.

#### DIRECT FIRE



*Figure 4, Direct Fire*

Figure 4 depicts a variety of direct fire weapon systems which could potentially be employed onboard LCAC. Intuitively, the most unsettling and controversial of the options would be firing a tank off an LCAC. The first impression is that fire overpressure at the muzzle would literally blow the doors and everything else off the LCAC. However, at a distance of 11 feet, the location of the superstructure, the PSI drops down to within two times the superstructure design criteria. A technological solution appears feasible.

The "initial" question is not whether it is technologically feasible but whether it has tactical merit. Does having a tank's firepower, seaward of the high water mark in direct support of an amphibious operation, enhance capability? If it does, then we



should evaluate this weapon system and other potential weapon systems for the viability of employing them on LCAC. The data bases regarding overpressures and impact loads are readily available. The impact of saltwater spray, foreign object damage, deck impact loads, and craft motion on the fire control system would require evaluation. A feasibility study is warranted.

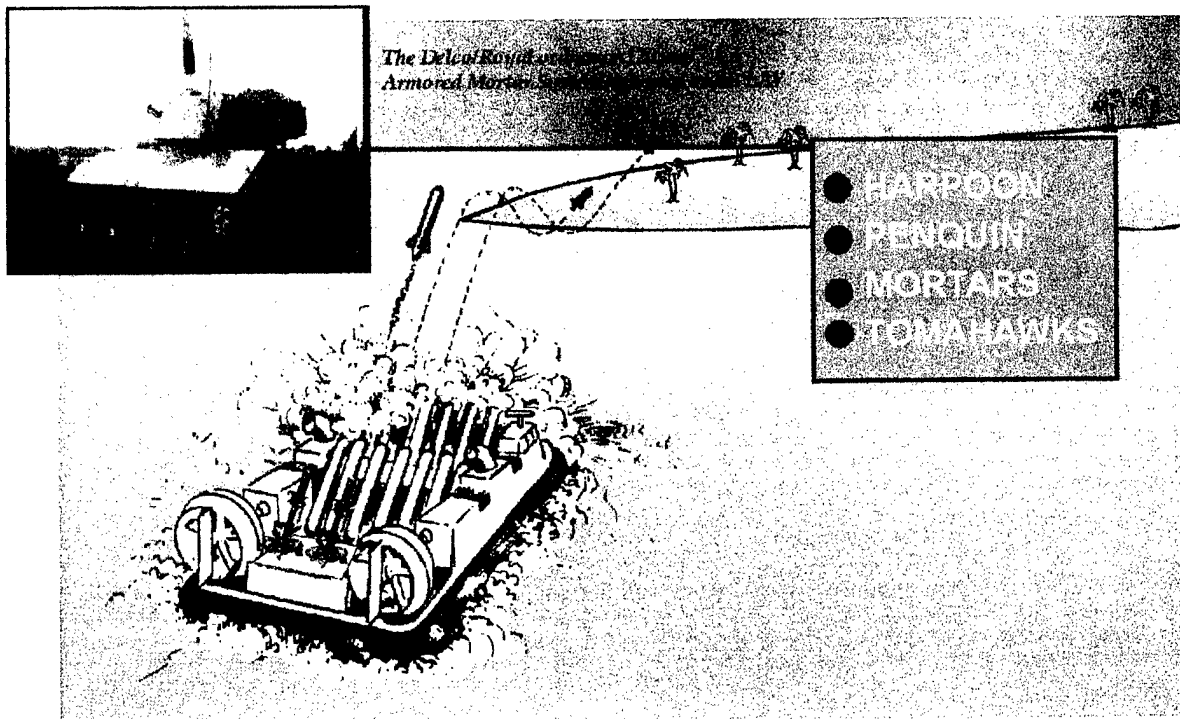


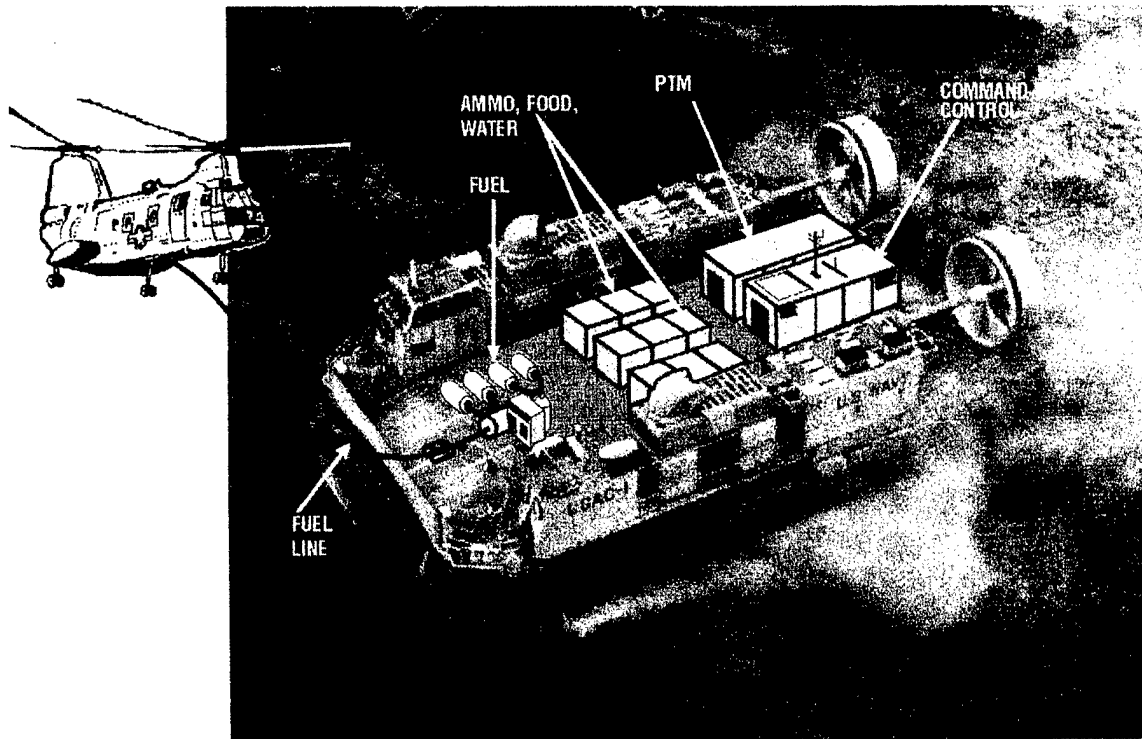
Figure 5, Indirect Fire Mobile Launch Platform

The LCAC also offers significant potential as a platform for indirect fire support. Figure 5 depicts various potential applications. The fire control solutions being adapted for Shallow Water Assault Breaching (SABRE) and Distributive Explosive Technology (DET) (shallow water mine breaching systems under development) have potential applications to mortars. Global Positioning System guided mortar rounds also offer capacity to put rounds on target from a moving platform. Indirect fire capability, on call, and transversing the coastline gives a whole new meaning to the "shoot and scoot" concept.

#### LOGISTICAL SUPPORT

The U.S. Marine Corps Battle Laboratory is currently investigating the possibility of employing numerous teams throughout a wide theater of operations with the intended mission of "shaping" the battlefield. Getting the teams into initial positions with a basic load is feasible. Providing responsive

follow-on logistical support will pose a significant challenge. A seabased Mobile Forward Arming and Refueling Point (MFARP), working in conjunction with helicopters, offers the opportunity to cover wide areas along a coastline.



*Figure 6, Mobile Forward Arming & Refueling Point (MFARP)*

#### SURVIVABILITY

There is a natural resistance by Marines to "giving up" their LCAC assets to other missions. Many of the arguments are justifiable. Using LCAC in multimission roles will detract in capability from LCAC's current mission. As the saying goes, there is no free lunch. We need to realistically project losses in time and equipment and evaluate the overall operational impact. Our current modeling and simulation capabilities are ideally suited to conduct the required tradeoff analysis and can provide a framework for optimizing the craft's utilization. The extent of degradation can be minimized by designing in rapid reconfiguration; optimizing when and how the craft is used; and most important, enhancing the craft's survivability.

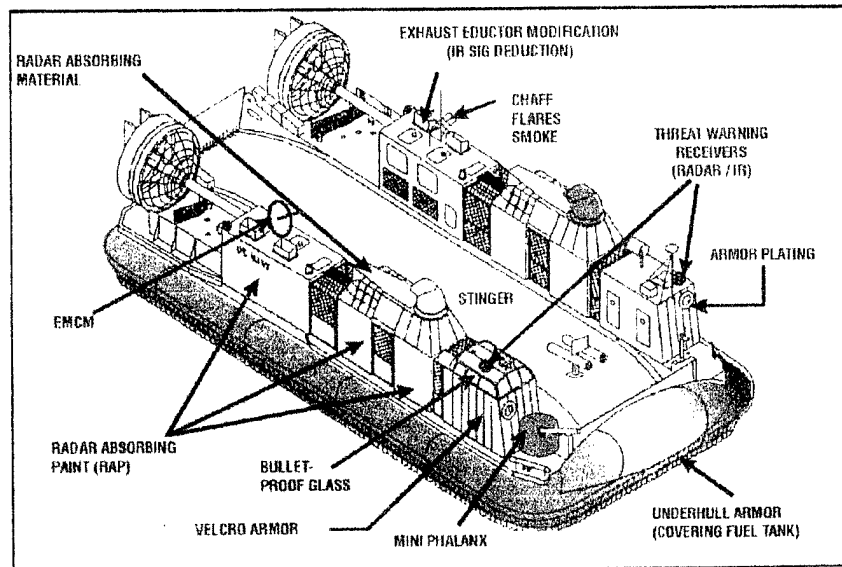
When the Navy elected to use LCAC for shallow water mine and obstacle breaching, we opened the door to placing the craft in

harms way. The LCAC produces signatures susceptible to infrared and radar guided threats and has extremely limited capability to take on fire. If we intend to expand the mission of the craft, special consideration must be given to analyzing the total threat environment, above and below the water, and developing a package to enhance survivability.

Considerable research has been completed regarding the craft threat signature. Existing technology can significantly reduce those signatures, as well as harden critical points. Threat reduction would be a combination of active and passive systems, as well as tactics.

Again, many systems designed to enhance aircraft survivability have application. In addition, those systems would not be restricted by the aerodynamic and weight limitations associated with airframes.

Although we can enhance survivability, employing the craft in a threat environment necessitates we realistically project losses and evaluate their impact on the overall mission.



*Figure 7, Total Threat....Total Survivability Pack*

#### TACTICS

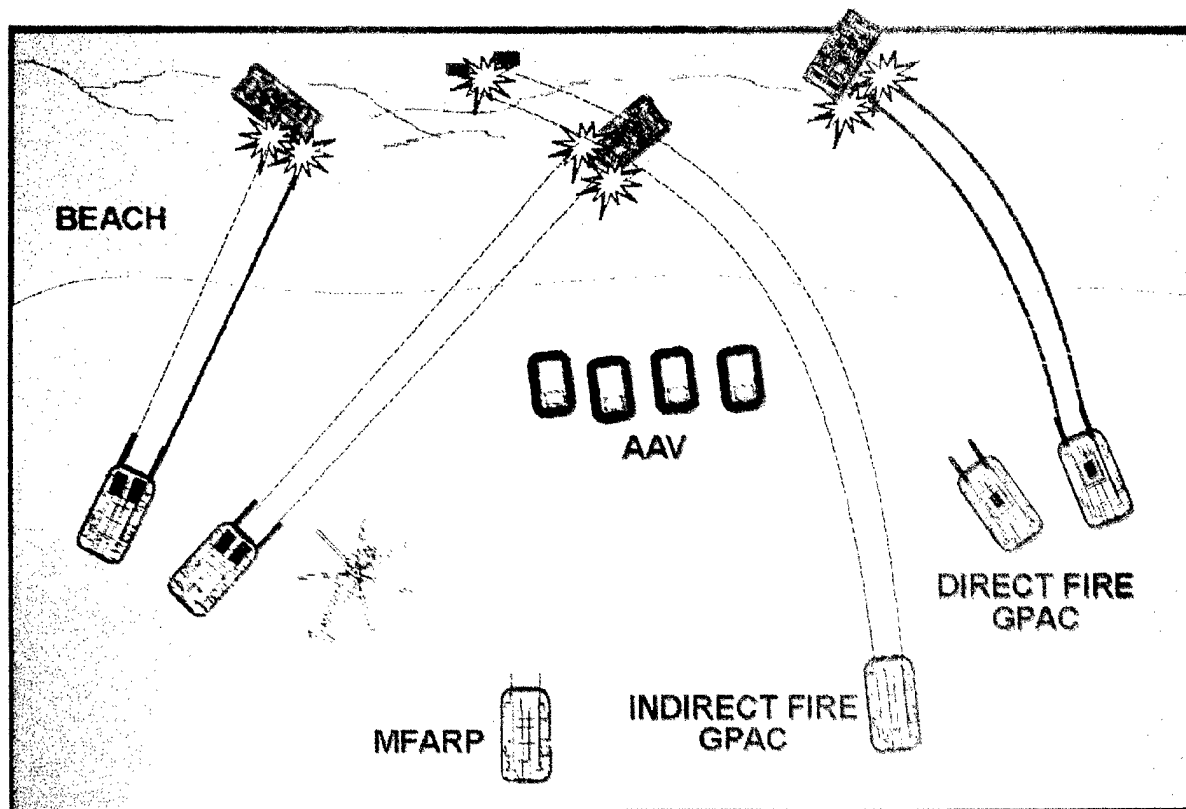


Figure 8, Amphibious OPS

Fire and maneuver from the sea takes on a new dimension as the precepts of "land" maneuver warfare can now be extended seaward of the high water mark. The following artist's renditions depict various tactical application of the previous concepts. A significant increase in firepower can be brought to bear during the most vulnerable time frames of an amphibious assault, the initial landing. Roll on/roll off capability of the direct and indirect fire systems affords us the capability to provide continuous fire support throughout the landing, from the shallow water through the beach, alleviating some of our current fire support shortfalls. LCAC based fire support could follow the initial assault inland or maneuver the coastline and provide supporting fires at other landing points or blocking positions. MFARPs provide greater latitude in responsive logistical support. The Commander now has a **seabased-fire/logistical-maneuver element** at his disposal. A whole new litany of tactical options become available.

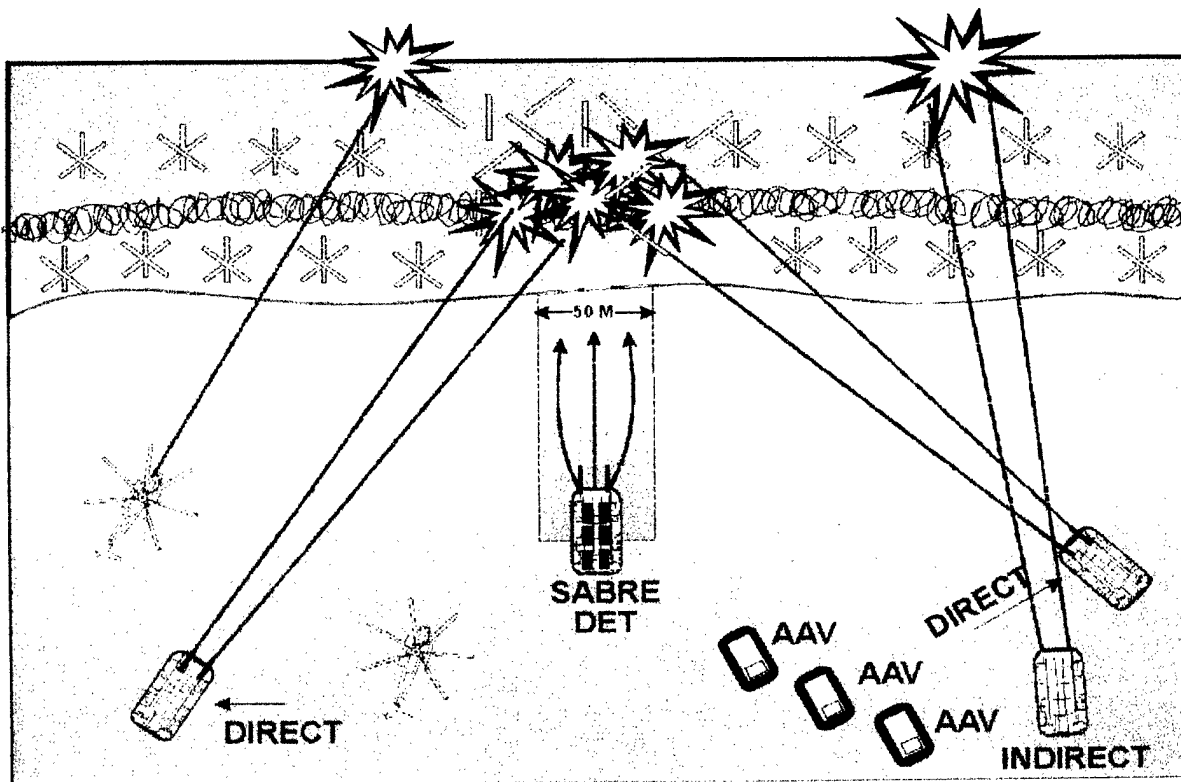


Figure 9, Amphibious OPS in a Mine/Obstacle Environment

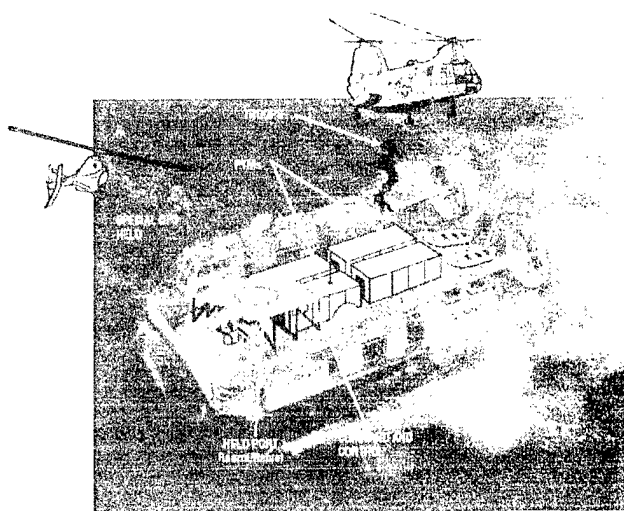


Figure 10, Special Operations

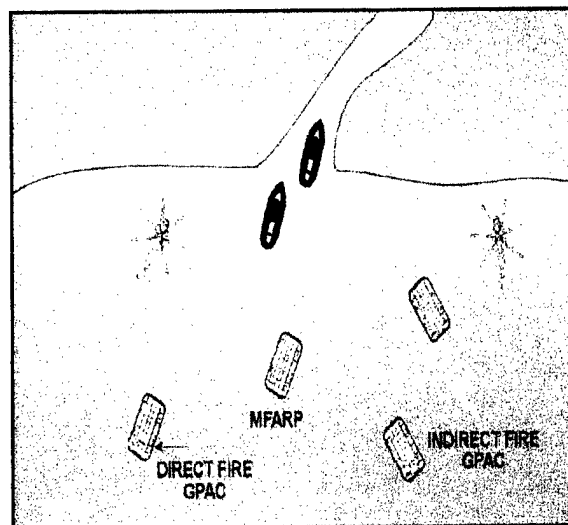


Figure 11, River OPS/Sea Dragon

## THE MID TERM

The "repackaging of existing assets" with the intent of operationally employing them off LCAC offers an immediate near term capability which will carry us into the next century. Tactically, the primary limiting factor is the in-water speed of the assault amphibious vehicle (AAV). When the advanced assault amphibious vehicle (AAAV) comes on line, the tactical concept really begins to take form. LCAC gunships teamed with AAAVs provides for a powerful and rapid shallow water maneuver force. MFARPs in trace could provide the first logistical resupply on land or while still at sea. Couple the speed and range of the V22 into the scenario and our capacity to project power into the littorals of the world will expand exponentially. The new systems not only fit the concept but significantly enhance the overall speed, flexibility, and range of the "seabased maneuver element."

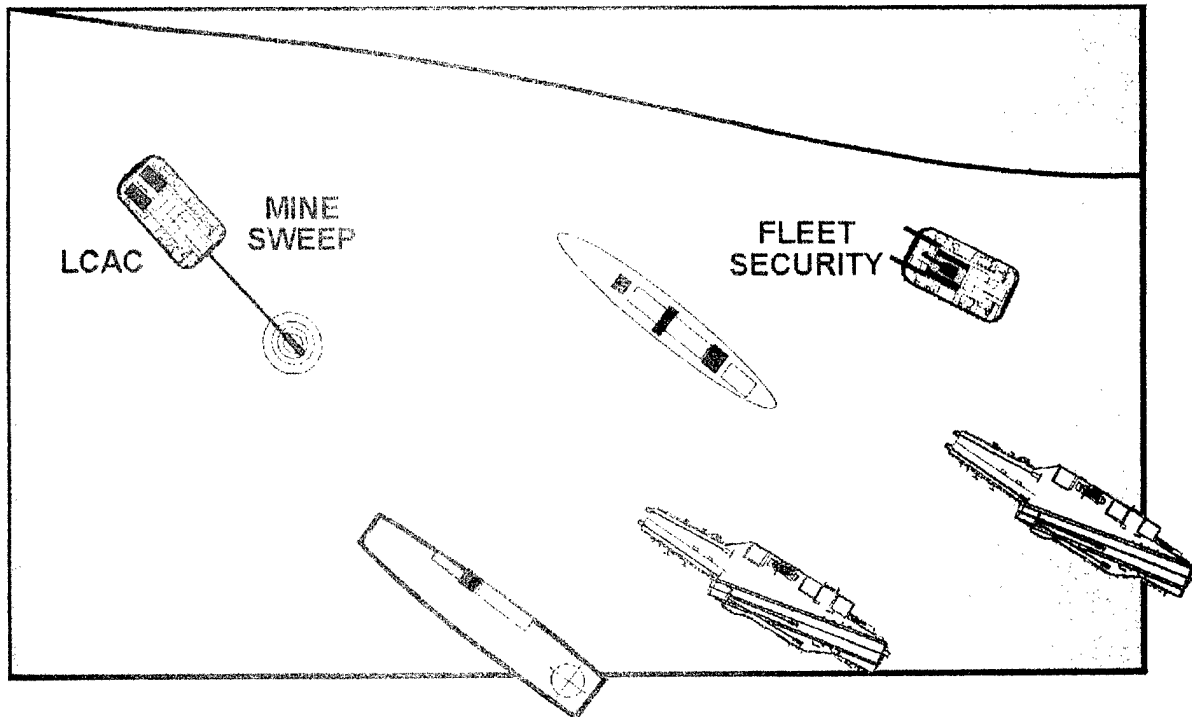
### "TRANSFORMERS" - A CONCEPT FOR THE FUTURE

In the near and mid term, we can package existing systems to meet a tactical concept. In the future, systems would be designed specifically "for" the concept. Oddly enough, we may be able to take a lesson from the toy industry. A few years back toy companies came out with a series of "transformer toys." They were quite an ingenious "war" toy that could be reconfigured into a variety of "capabilities" to meet a young child's imaginary "tactical" requirements. What started out as an aircraft could with a couple of twists be transformed into a rocket firing ship which could separate into a tracked futuristic tank which could... It was an amazing little toy but far more interesting is the implied concept.

- Weapon systems could be operated as integral part of a generic platform or could disengage and operate independently.
- The the same weapon systems were designed to be effective in multiple physical environments -- land, air, and sea.
- Minimal time and effort were required to "transform" the systems to the required mission and the environment.

The concept has potential application to our future combat systems and, in particular, LCAC. Future generations of LCAC could be specifically designed as a multimissions platform. Survivability from land, air, and sea threats would be built into the craft. While our current ground systems are simply weight and cube until they come ashore, future systems could be designed to be equally effective employed at sea off LCAC or on land. The integration of the seabased platform and the ground weapon system would be an integral part of the design of both systems.

During transit, the LCAC mounted system could be employed on the flanks of the Fleet and provide ASW, anti-air, or security against highspeed boats. Minehunting and sweeping would proceed the Fleet.



*Figure 10, Alternate Mission*

During amphibious operations, they would provide indirect and direct fire support which could "immediately" transition ashore to continue the land battle. MFARP, Special Operations, and Riverine Operations would be ancillary missions. The craft could be rapidly configured to meet the multiple missions.

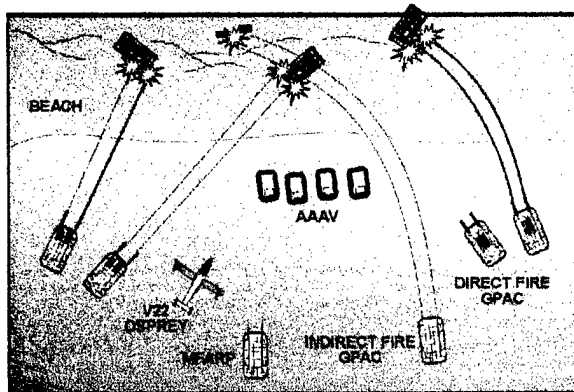


Figure 11, Amphibious OPS  
Initial Assault

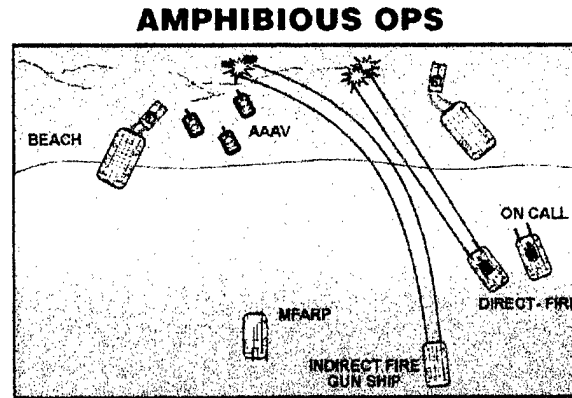


Figure 12, Amphibious OPS  
Landing

Designing ground based systems to operate "at sea" would significantly leverage our Naval as well as Marine Corps capability and expand both services tactical options.

#### CONCLUSION

The development of LCAC represents a major step forward in amphibious capability. However, we have barely begun to capitalize on its potential. By "packaging" existing systems and "employing" them onboard LCAC, we can significantly enhance our combat capabilities and broaden our tactical options, in the near term and without significant capital outlay. The potential applications include direct and indirect fire, logistical support, and special operations. Integrating the capabilities provides the Commander a seabased fire and maneuver element and the capacity to apply the precepts of maneuver warfare throughout the battlefield, from deep water seamlessly through the beach. The concept has application today, as well as in our future development efforts.

#### ACKNOWLEDGMENT

A special acknowledgment goes to Mr. George C. Betz, Jr., Amphibious Craft Branch, Coastal Systems Station, Dahlgren Division, Naval Surface Warfare Center, Panama City, Florida. He is singularly responsible for initiating much of the research and making the gatling gun prototype a reality. In an era when it takes 7-10 years and millions of dollars to build a system, this prototype was built and tested in less than 60 workdays at a cost of \$60,000.

Special mention also goes to Mr. Charles McClenahan, Wright Laboratories (MNAV), Eglin Air Force Base, Florida, and the crew at the Ballistics Experimentation Facility. Through their sweat, knowledge of Air Force systems, and innovation, actions were



expedited. Their current efforts include adapting the seeker section from an AGM-65A/B or AGM-130 for fire control/targeting of the GAU-13/GPU-5 system.

Further efforts are not currently funded. Planning and concept development continue on a limited basis.

## **D8 TRACTOR / ISRAELI MINE PLOW (IMP) MINE AND OBSTACLE CLEARANCE TESTING**

John P. Wetzel <sup>1</sup>

### **ABSTRACT**

The Israeli Mine Plow (IMP) is a piece of mine countermeasure (MCM) equipment developed by the Israeli government for the clearance of mines and obstacles. The IMP was attached to a D8 tractor and tested against mines (M20 and VS-1.6) and hardened obstacles (jersey barriers, tetrahedrons, hedgehogs, concrete cubes, concertina wire). Testing was conducted in sand at Tyndall AFB and in hard pack soil at Ft Rucker. Four assault lanes consisting of mines/obstacles, each 100 feet long, were set up. Four wide area sections consisting of mines/obstacles, each 100 feet by 100 feet, were also set up. Each of these four assault lanes and four wide area sections were tested in sand and hard pack soil. The IMP performed well in these MCM clearance tests. A summary of results of the IMP testing is presented in this paper.

### **IMP SYSTEM DESCRIPTION**

The IMP consists of a 19 foot wide "V"-shaped plow with a set of 15 inch long tines extending down from the bottom of the plow. As originally configured, the plow was attached to a "C-frame". The C-frame was attached to the D8 (or D9) tractor in

place of the 8S blade and push arms. The C-frame was also attached to the tractor's cylinders, through which plow depth was controlled. Pilot lights connected to tracker arms on the front provided the operator with an indication of plowing depth.

This configuration, however, did not allow for the operator to control tilt of the IMP. To circumvent this, the attachment was modified to incorporate a direct mount to the 8S blade of the D8 tractor in place of the C-frame. This modification provided the operator with full tilt and lift control of the IMP through the standard blade hydraulic controls. The tracker arms and skid shoes were removed to facilitate sidecasting of obstacles. In addition, an 18 inch high steel mesh fence was fabricated and attached to the top of the IMP to provide additional height during mine clearing operations. Figure 1 shows the IMP mounted to the D8 tractor.

With the 12,000 pound IMP mounted on the front of the blade, the center of gravity (CG) of the tractor was moved forward, which adversely affected the tractive performance of the D8 and control of IMP depth. To offset the CG problem, 8,000 pounds of ballast was mounted to the ripper assembly on the rear of the tractor.

---

<sup>1</sup> IMP Project Chief Engineer, WL/FIVCF, Tyndall AFB, FL 32403

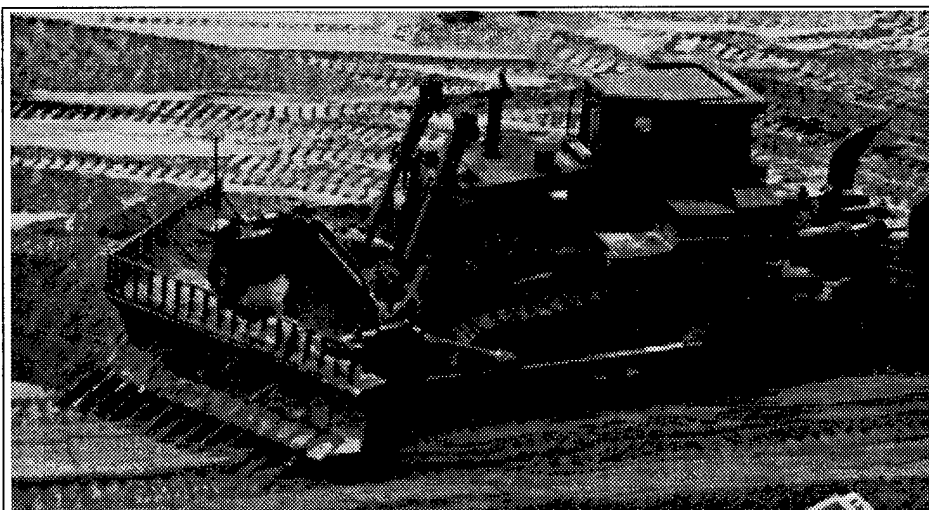


Figure 1. IMP Mounted to D8 Tractor

### IMP TEST OBJECTIVE

The purpose of this test was to evaluate the performance of the IMP attached to the blade of a Caterpillar D8N tractor. Performance measurements include the ability of the IMP to clear an assault lane (25 ft x 100 ft) of mines and obstacles, the ability of the IMP to clear a wide area (100 ft x 100 ft) of mines and obstacles, plow depth achieved, and the time required to clear specified areas. Performance was measured over flat terrain in sand and hard pack soil conditions.

### IMP TEST SETUP

#### Test Fields

Two types of test fields were prepared for the IMP test program. The first type was the assault lane test field. Tests in these fields required that the IMP be able to clear a path through the lane in a single pass wide enough for a follow-on column of combat support vehicles. The second type of test field was the wide area clearance field. Tests in these fields required that the IMP clear a wide area (100 ft x 100 ft), including entry and exit areas, for larger ground

support operations and transport vehicles such as Landing Craft Air Cushions (LCACs).

Four assault lanes were prepared for sand (CBR 12) and hard pack (CBR 22) soil. Two lanes incorporated "Mines Only", with one lane containing 33 M20 practice mines, and the other lane containing 33 VS-1.6

practice mines. One lane incorporated "Obstacles Only", with 3 Jersey Barriers, 5 Tetrahedrons, 8 Hedgehogs, and 6 Concrete Cubes. The final lane incorporated "Obstacles and Mines", containing the obstacles and 24 M20 practice mines. A layout of the "Obstacles and Mines" assault lane is shown in Figure 2.

Four wide area test fields were prepared for sand and hard pack soil. Two wide areas incorporated "Mines Only": one containing 116 M20 practice mines; and the other containing 40 VS-1.6 practice mines and 76 wooden simulants. The other two wide areas incorporated "Obstacles and Mines": containing 9 Jersey Barriers, 3 sections of concertina wire fence, 20 Tetrahedrons, 20 Hedgehogs, 14 Concrete Cubes, and 36 M20 practice mines. A layout of the "Obstacles and Mines" wide area test field is shown in Figure 3.

#### Mine Types

The M20 practice mines and the VS-1.6 inert mines were the two types of mines used to evaluate the IMP's mine clearing performance. Both mine types utilize pressure initiation fuze mechanisms. Each mine is initiated by different kinds of pressure mechanisms and each have

different thresholds for pressure initiation. M604 fuzes were installed into the M20 fuze wells prior to each test to be able to determine if the M20 mine would have detonated. The VS-1.6 mines contain a resettable mechanical firing pin that was used to visually indicate whether or not the mine detonated.

All mines were uniquely labeled to determine the initiation and casting performance. Due to the limited quantity of VS-1.6 mines available for this test program, wooden simulators were used as a third mine type in place of some of the VS-1.6 mines for wide area testing.

For each test field, one quarter of each mine type used was surface-laid. The remaining three quarters were buried with three inches of soil overburden. The distribution of the VS-1.6 mines and wooden simulators



Figure 2. "Obstacles and Mines" Assault Lane

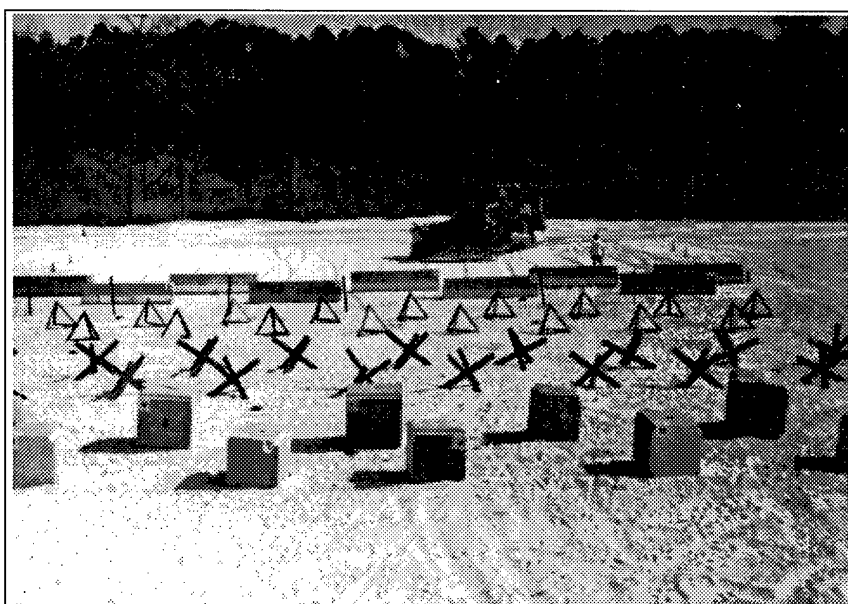


Figure 3. "Obstacles and Mines" Wide Area Test Field

were selected so as to maintain a uniform density of each mine type throughout the test area. In addition, the distribution of the surface and buried mines were also selected to maintain uniform densities over the test area.

#### Obstacles

Five types of hardened obstacles were used to test the IMP's clearing performance. Concertina wire was also placed onto the wide area as an obstacle for these tests. Table 1 lists the types of

obstacles used in this test and their physical properties. All obstacles were uniquely identified so that their initial and final positions could be measured to determine the casting/clearing performance of the IMP.

Table 1. IMP Test Obstacles

Obstacle Type	Size	Weight
Concrete Cube 1	4 ft cube	9000 lbs
Concrete Cube 2	3.5 ft cube	6000 lbs
Iron Hedgehog	5.5 ft star	525 lbs
Steel Tetrahedron	4 ft edge	300 lbs
Jersey Barrier	12 ft long	4800 lbs
Concertina Wire & Engr Stakes	12 ft long	N/A

**IMP TEST RESULTS**

Data for the sand and hard pack soil conditions was collected for each of the tests outlined above. A summary of this data is presented in the following sections. A complete detailed Test Report of the results from the IMP testing is maintained on file at WL/FIVC.

Assault Lane Testing

No mines were found in any of the IMP's cleared path for the "Mines Only" tests. One M20 fuze was detonated during the clearing process. The IMP cleared an average path 14 feet 9 inches wide, in an average of 52 seconds. Figure 4 shows an example of the IMP casting performance for the M20 practice mines.

All the obstacles in the lane were removed from the IMP cleared path for the "Obstacles Only" tests. The IMP cleared an average path 15 feet 2 inches wide, in an average of 70 seconds. Figure 5 shows an

example of the IMP casting performance for obstacles.

The IMP removed all of the obstacles and mines from the IMP cleared path for the "Obstacles and Mines" tests. The IMP cleared an average path 14 feet 10 inches wide, in an average of 121 seconds. Table 2 shows a summary of the test data for all of the assault lane tests.

Table 2. IMP Assault Lane Test Data Summary

ASSAULT LANE	Mines-Only	Obstacles-Only	Obstacles & Mines
Clearing Time	52 sec	70 sec	121 sec
Tine Depth	18 in	15 in	18 in
Cleared Width	14' 9"	15' 2"	14' 10"
Mines Cleared	100% (70 of 70)	N/A	100% (24 of 24)
Fuzes Detonated	1% (1 of 70)	N/A	4% (1 of 24)
Obstacles Cleared	N/A	100%	100%

Wide Area Clearance Testing

Analysis of the four wide area "Mines Only" test fields demonstrated that 7 of the total 464 mines (2% of the M20, VS-1.6, and wooden simulants) were not removed from the test field area (100 ft x 100 ft), including the entry and exit areas. Eight percent of the fuzes were found to be detonated upon recovery. The location at which the mines detonated was not quantified during testing. Therefore, it is unknown how many of these detonations would have been in the proximity of the IMP. Average clearing time for these tests was 52 minutes. Figure 6 shows the IMP being used to clear a wide area test field of M20 practice mines.

HARD PACK @ FT. RUCKER

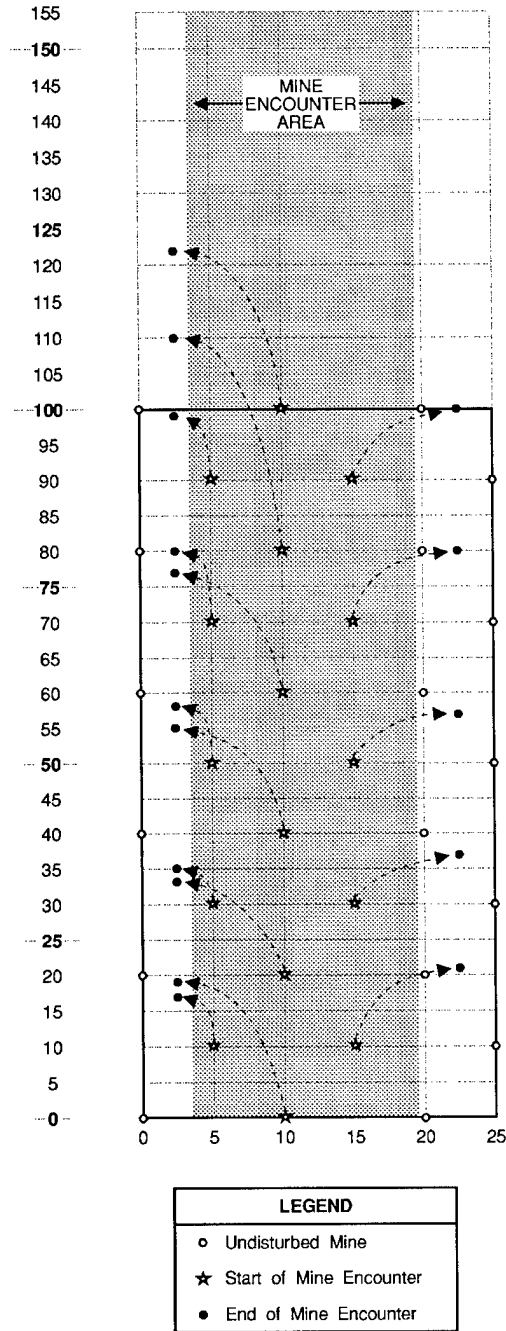


Figure 4. IMP Assault Lane M20 Mine Casting Performance

SAND @ TYNDALL

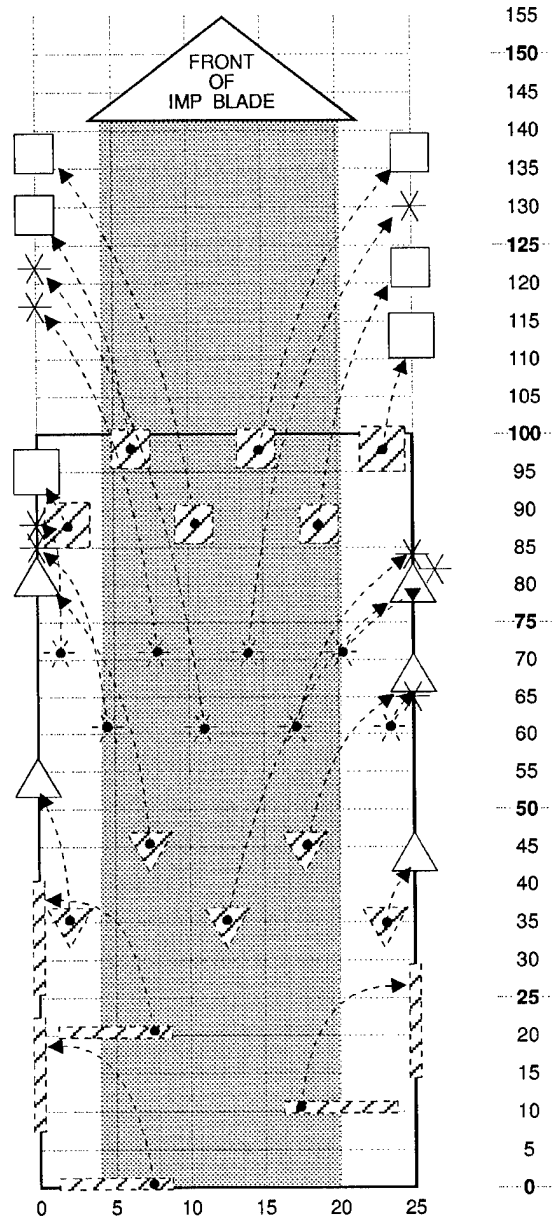


Figure 5. IMP Assault Lane Obstacle Casting Performance



Figure 6. IMP “Mines Only” Wide Area Test Field Clearance

Results from the wide area “Obstacles and Mines” test field indicated that 1 of the total 144 mines (1% of M20’s) were not removed from the test field area (100 ft x 100 ft), including the entry and exit areas. Twenty-one percent of the fuzes were found to be detonated upon recovery. As in the previous wide area tests, the location at which the mines detonated was not quantified during testing. Average clearing time for these tests was 54 minutes. Figure 7 shows the IMP being used to clear a wide area test field of obstacles and M20 practice mines. Table 3 shows a summary of the test data for all of the wide area test fields.

Table 3. IMP Wide Area Clearance Test Data Summary

<b>WIDE AREA</b>	<b>Mines-Only</b>	<b>Obstacles &amp; Mines</b>
Clearing Time	52 min	54 min
Tine Depth	19 in	19 in
Cleared Width	>100 ft	>100 ft
Mines Cleared	98% (453 of 464)	99% (142 of 144)
Fuzes Detonated	8% (25 of 312)	21% (30 of 144)
Obstacles Cleared	N/A	100%

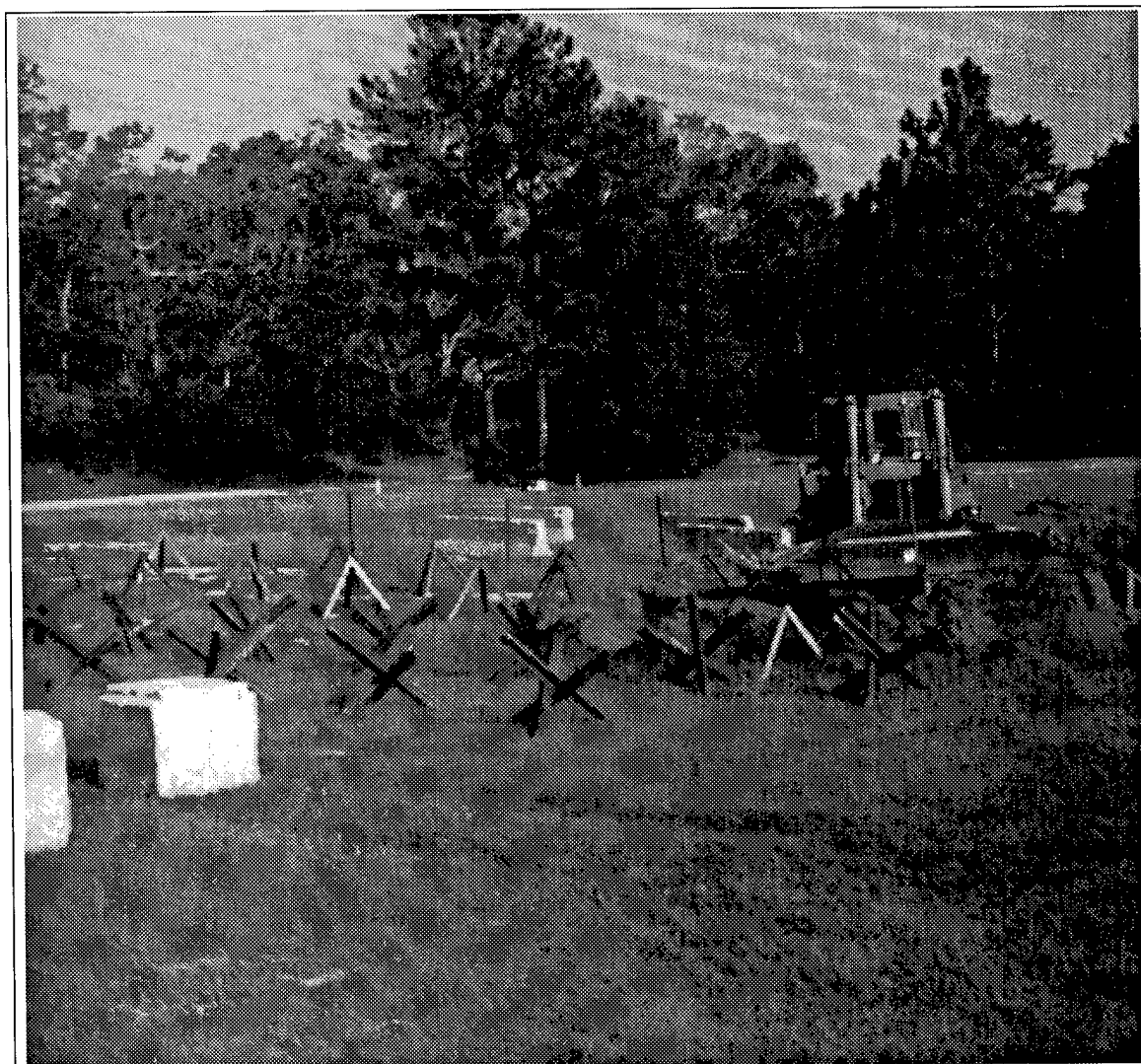


Figure 7. IMP "Obstacles and Mines" Wide Area Test Field Clearance

#### ACKNOWLEDGMENTS

This work is being sponsored by the Marine Corps Systems Command (MARCORSYSCOM) Program Manager Engineer Systems (PM-SSE). The authors would like to acknowledge the dedicated effort of the IMP test team and the support troops from Camp LeJeune.





**Reduced Wavenumber Synthetic  
Aperture  
for MCM Applications**

Ira Ekhaus  
Synap Corporation  
100 Wildwood Ave  
Arlington, MA  
02174  
ekhaus@synapcorp.com

**ABSTRACT**

Performance of existing Mine countermeasures (MCM) underwater acoustic remote sensing systems are limited by the sonar front end. Designers of next generation systems must choose between the relatively poor performance of traditional real beam side scan systems (multibeam included) and unproven synthetic aperture sonar (SAS) designs. While the potential of high resolution SAS to provide unprecedented detection and discrimination performance is clear, the real world issues of residual platform motion and temporal/spatial variations in sound speed (SSP) have prevented operational deployment of existing designs. These problems have provided much incentive for research in autofocusing and motion compensation techniques as they apply to the sonar environment.

Synap Corporation has developed a unique Reduced Wavenumber Aperture Synthetic Aperture (REWSA) technology that is inherently robust to the effects of the sonar environment. This paper presents a theoretical discussion of synthetic aperture's inherent vulnerability to the effects of the sonar environment as due to the relatively high wavenumber of underwater sound waves, and demonstrates how the REWSA algorithm mitigates the problems of motion compensation and temporal/spatial SSP variations by effectively reducing the wavenumber as seen by the system.

This work sponsored by NOAA under Contract  
50-DKNA-5-00206

## 1 Sonar in Mine Countermeasure (MCM) applications

The challenge in designing high performance acoustic imaging systems (especially in mine hunting applications) is to achieve the best tradeoff among the mutually exclusive quantities of resolution and coverage rate. For Mine Countermeasures (MCM) applications, the system specification must be broadened to include the detection or post-processing stage (often image based) and special attention must be paid to the cost of a missed detection.

Consider a generic imaging/detection system (Figure 1) whose front end takes signals from a plurality of sensors and forms an image, and whose back end involves an image based approach to detect and discriminate targets from clutter. For radar remote sensing applications, synthetic aperture (SAR) techniques have evolved to where a majority of the physics is considered in the system's front end (synthetic aperture), and the tasks of detection, estimation and discrimination are addressed in the image processing stages. In these systems, operator workload is drastically reduced by the fact that the SAR processing has, through increased resolution, distilled out a majority of the physics based target interaction that would otherwise confound the image processing with signal artifacts.

Figure 3 shows the the real component of the baseband returns vs time and track for a set of 3 closely spaced targets; this is the *input* to the SAR system. The constructive and destructive interference, beam pattern modulation and phase delay corresponding to the varying geometry are all clearly visible. If, after SAR processing, any residual structure in the underlying phase of an image (such as would be generated by a moving target [Sou92]) remains, then it should be *systematically* exploited by a modified SAR front-end. The subtle nature of the data, as demonstrated in this complex image, is a primary reason that the final image (and the feature space for detection and discrimination)

COMPLEX  
VECTOR  
DATA

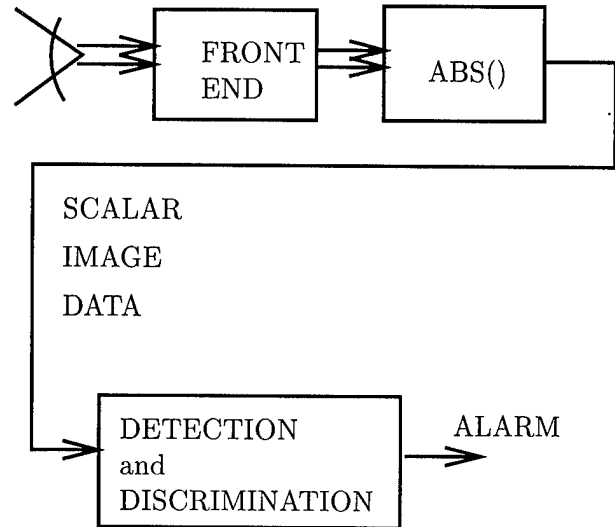


Figure 1: generic imaging/detection system

is often constrained to be only *magnitude* data.

For the MCM application in the underwater environment this discussion has left out the all important fact that a robust, operational Synthetic Aperture Sonar (SAS) system has heretofore been infeasible. Consider figures 7 and 10 where the image of a 3pt target is simulated for both SAS and REWSA under 3mm and 30mm of RMS motion respectively. Subsequent discussion of *why* SAS has difficulties in the sonar environment (Section 2), should not detract from the fact that without a robust synthetic aperture front end, image quality (and clutter discrimination and classification performance) are severely downgraded.

### 1.0.1 The need for Synthetic Aperture in MCM applications

Existing MCM detection systems must employ a real beam system (as opposed to SAS)

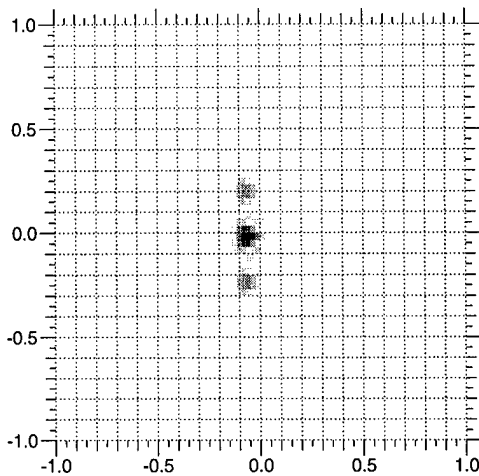


Figure 2: 3 pt target field

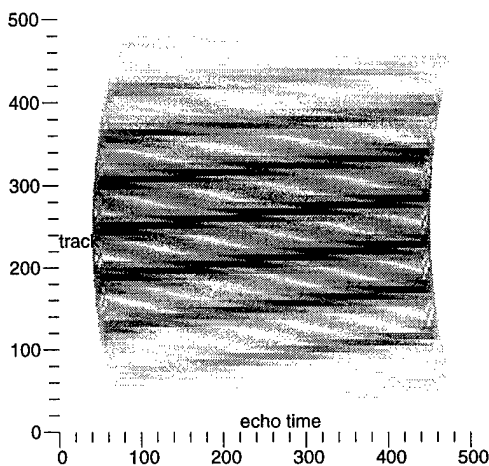


Figure 3: baseband response vs time and track for 3 pt target

whose lower horizontal resolution passes along a prohibitive amount of physics-based signal artifacts such as the interference terms of the various scatterer centers of a mine (i.e. Figure 3). Without some form of SAS processing, information that could have gone to increasing system resolution becomes an additional source of modeling error instead of a valuable source of discriminant.

The factors that prevent the operational deployment of present SAS designs are extreme sensitivity to unmodeled motion of the sensor platform along with variations of the sound speed

across the track that forms the synthesized aperture. Heretofore, motion-compensation and auto-focusing are the two primary ways that the sonar community has tried to mitigate these effects [BFWW87, ISMF85, Joh94, B. 93]. In (Section 2) we demonstrate that the SAS “problem” can be summarized as a requirement that position be known to a small fraction of a wavelength. An alternative technology, the Reduced Wavenumber Synthetic Aperture algorithm (REWSA) sidesteps this issue and will be discussed shortly.

## 1.1 Summary

The problem of remote sensing in the context of MCM, is to define techniques and methodologies that can extract the *absolute maximum information* from acoustic signals as it applies to the detection and discrimination of bottom clutter and false targets from either natural or man-made objects on or near the seafloor bottom (floating or buried). We believe that essential design features of a next generation MCM detection and discrimination system must include:

1. High resolution synthetic aperture designs that can operate robustly in the underwater environment.
2. Robust, accurate modeling of phenomenology unique to the sonar environment such as multipath returns and relatively high wavenumber target returns.
3. Tight integration of the synthetic aperture processing and model-based detection stages.
4. Consistent, well-defined techniques for image generation and detection that can exploit advances in other technology areas.

## 2 Synthetic Aperture

### 2.1 Introduction

Herein we discuss the *inherent* weaknesses in existing SAS designs, and show a technol-

ogy (REWSA) that circumvents long standing problems. The operating principle of REWSA is best introduced by the starting with wavenumber synthetic aperture [Sou92], a formal SAR technique that decomposes a spherical wave return to a sum of plane waves and as a result does not require an approximation to the quadratic phase vs track position.

### 2.2 “Traditional” Synthetic Aperture signal model

Consider a two-dimensional imaging system comprised of a transceiver (transmit and receive elements) 4 traversing a track 10 at position  $u_i, 0 \leq i \leq M$ . The system operates in a monostatic measurement scenario (figure 4), with reflectivity function of the target field  $\alpha(x, y)$  a function of Cartesian grid  $(x, y)$  (Without loss of generality, the mapping between the 3D slant range plane and the 2D image plane is deferred). For the mono-static case (Figure 4), the acoustic paths [transmitter/object] 16 and [object/receiver] 18 are drawn as essentially the same.

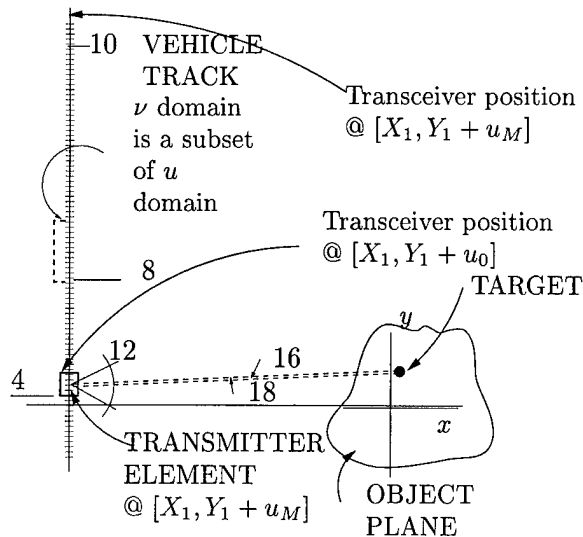


Figure 4: Monostatic SAR (SAS) measurement scenario

The 2D spatial spectra is defined as position in the target plane with spatial wavenumbers  $k_x, k_y$  and whose spatial transform, denoted by

$\Psi(k_x, k_y)$  is defined as

$$\Psi(k_x, k_y) = \int_x \int_y \alpha(x, y) e^{-jk_x x} e^{-jk_y y} dx dy. \quad (1)$$

The target or object area is illuminated by the transmitted signal and lays within a disk of radius  $X_o$  centered at the origin in the spatial domain  $(x, y)$ . The wavenumber of a wave with temporal frequency  $\omega$  traveling in this medium is defined as  $k = \omega/c$ . The transmitted signal is multi-frequency such as a FM chirp or short duration pulse with beam pattern 12. that determines the subset of  $u_i$  wherein the target within the object plane is illuminated (ensonified).

Received signals are obtained as echoes from the objects within the target plane, by appropriate signal conditioning and sampling procedures on the receive elements. Assuming that the additional REWSA data dimension of  $\nu$  can be viewed as a hidden parameter (this will be explained in section 2.3), then a REWSA processor *operates on the same raw data as traditional SA system designs*. The received signal (sample plot in figure 3), a sum of all echoes from objects within the target region as a function of along track position  $u$  and echo delay (“fast time”)  $t$  is defined as:

$$s(t, u) = \int \int \alpha(x, y) p \left[ t - \frac{2 | [X_1 - x, Y_1 + u - y] |}{C} \right] dx dy \quad (2)$$

where  $[0, 0]$  is the center of the target image plane (Figure 4), and the differential area  $dx dy$  contribute reflected energy proportional to  $\alpha(x, y)$  the target reflectivity function at target point  $[x, y]$ , delayed by twice acoustic path between the transceiver at  $[X_1, Y_1]$  and target point. The transmission signal  $p(t)$  and received signals  $s(u, t)$  are complex baseband signals.

#### 2.2.1 Wavenumber Characterization of Linear SA

The temporal Fourier transform (FT)  $t \rightarrow \omega$  is computed with the conventions defined in the standard literature as

$$s(\omega, u) = P(\omega) \int \int \alpha(x, y) \underbrace{e^{-j2k\sqrt{(X_1-x)^2+(Y_1+u-y)^2}}}_{\Phi_{pf}} dx dy. S(\omega, k_u) = P(\omega) e^{jk_x X_1 + jk_u Y_1} \Psi(k_x(\omega, k_u), k_u), \tag{7}$$

where the wavenumber  $k$  and spatial variables  $x, y, X_1, Y_1, u$  have been previously defined.

The complex exponential  $\Phi_{pf}$  is interpreted as the spherical wave due to the reflection from a point scatterer position at  $[x, y]$  illuminated (enslaved) by a transmitter at  $[X_1, Y_1]$  and can be restated as a sum of plane waves

$$\Phi_{pf} = \int_{-2k}^{2k} \frac{1}{\sqrt{4k^2 - k_u^2}} e^{-jk_x(X_1-x) + jk_u(Y_1+u-y)} dk_u \tag{4}$$

where the relation between the measurement wavenumbers and the target plane wavenumbers is

$$k_x = \sqrt{4k^2 - k_u^2}, \quad k_y = k_u \tag{5}$$

and in order to simplify the following presentation, we focus on the phase functions and suppress the amplitude function  $\frac{1}{\sqrt{4k^2 - k_u^2}}$ . Incorporating equation 4 into equation 3 yields

$$s(\omega, u) = P(\omega) \int_{-2k}^{2k} e^{-j2k_x X_1 + jk_u Y_1} e^{jk_u u} * \int \int \underbrace{\alpha(x, y) e^{-j(k_x x + k_u y)} dx dy}_{\text{2D Fourier integral}} dk_u = P(\omega) \int_{-2k}^{2k} e^{-j(k_x X_1 + k_u Y_1)} \Psi(k_x, k_u) e^{jk_u u} dk_u \tag{6}$$

The measurement spectra is now related to the target plane spectra *linearly*. Computing the spatial Fourier Transform  $u \rightarrow k_u$  of  $s(\omega, u)$  yields the *algebraic* relation between the measurement spectrum  $S(k_u, \omega)$  and target reflectivity spectrum  $\Psi(\cdot)$  as

where variables  $u/k_u$  are the along track offset / wavenumber pair,  $k_w$  is the propagating wavelength at frequency  $w$ ,  $x/k_x$  is the across track range/wavenumber pair ( $k_x$  satisfying equation 5),  $X_1$  is the nominal across track range to target, and  $Y_1$  is the along track offset of the target. Equation 7 is then inverted to provide an estimate of  $\Psi(k_x, k_u)$  as

$$\hat{\Psi}(k_x(\omega, k_u), k_u) = P^{-1}(\omega) \underbrace{e^{-jk_x X_1 - jk_u Y_1}}_{\text{phase function}} S(\omega, k_u). \tag{8}$$

A 2D inverse spatial FT can be applied to  $\hat{\Psi}(k_x(\omega, k_u), k_u)$  to yield an estimate of the target plane image as

$$\hat{\alpha}(x, y) = | FT^{-1}[\Psi(k_x, k_y)] | \tag{9}$$

where the notation  $| |$  is the absolute value operator. This is the last step in a traditional synthetic aperture system.

### 2.2.2 Operational feasibility of Existing SA Designs

In actuality, the transceiver position  $[X_1, Y_1]$  undergoes perturbations during measurement and is more accurately describe by  $[X_1 + X_1(u), Y_1]$ . In this case  $s(\omega, u)$ , as defined by equation 3, depends on a phase function

$$e^{-j2k\sqrt{(X_1+X_1(u)-x)^2+(Y_1+u-y)^2}} \tag{10}$$

that explicitly varies with  $u$ , and the correction for this factor must be introduced before the spatial Fourier Transform  $u \rightarrow k_u$  of  $s(\omega, u)$ . Although a full statistical analysis of a system's output is past the scope of the current paper, the inherent vulnerability of existing SA techniques is clearly seen by applying the phase correction term (with  $\hat{X}_1$  the track estimate)

$$e^{-jk_x \hat{X}_1 - jk_u Y_1} \tag{11}$$

to equation 8. This yields a simple relation between residual motion error

$$\Delta_{X_1} = X - \hat{X} \quad (12)$$

and the residual phase error term  $e^{jk_x \Delta_{X_1}}$ . If we define a requirement for phase coherence as limiting the RMS of the argument to this complex exponential to less than  $\frac{\pi}{4}$ , then this requires

$$\Delta_{X_1} < \frac{\pi}{4 k_x} \quad (13)$$

For a sonar system operating at 100 KHz, with wavenumber  $k \sim 400$ , this translates to a limit of

$$RMS(\Delta_{X_1}) < \frac{\pi}{4 * 2 * 400} \sim 1mm. \quad (14)$$

The severity of this tight operational specification is demonstrated in figures 5, 6 and 7 for the example case of a 100Khz sonar where the resultant image smearing is displayed for a transceiver system undergoing 3mm (RMS) of across track motion.

To mitigate these phase randomizing effects, motion compensation techniques strive to measure the absolute position of the transceiver to accuracies well within a wavelength such that  $RMS(k_x \Delta_{X_1}) \ll 1$ , while autofocusing techniques assume a structure to the received signal to back out what the motions must have been [SC92]. For sonar applications, both approaches are exacerbated by the following:

1. Relatively high wavenumber of high frequency sonar.
2. Extremely high ratio of random kinematic forces to inertial forces that impart uniquely high motions .
3. Even if the transceiver is bolted to an underground rail there will be significant phase noise imposed by the environmental variability in the SSP of the underwater environment .

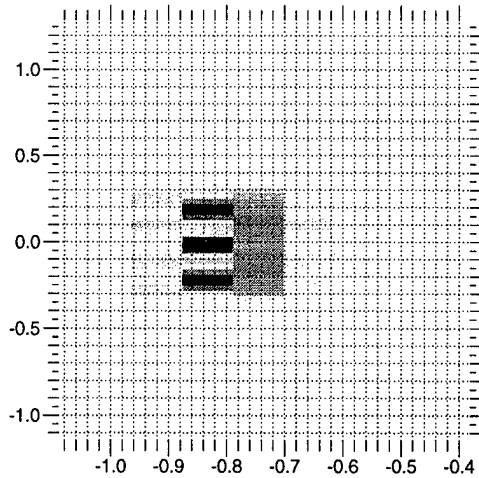


Figure 5: Synthetic Aperture image formed under RMS motion  $\sigma_x = 0.0mm$

A primary feature of the present discussion is that the residual phase error embodied within the REWSA equivalent to equation 8 can be substantially attenuated by “reducing” the equivalent wavenumber of the inversion, hence the name “REduced Wavenumber Synthetic Aperture” or REWSA.

### 2.3 REWSA Algorithm

In order to reduce the characteristic horizontal wavenumber of the system of the present invention, we form the conjugate (interferometric) product of the spectral and motion compensated signal  $s_{m\omega}(t, u)$  defined as

$$\begin{aligned} S_{m\omega}(\omega, k'_u) &= \Psi(k_x, k_y) e^{jk'_x(X_b - \hat{X}_b)} e^{j(k'_u Y_1)} \\ &= \Psi(k_x, k'_u) e^{jk'_x \Delta_{X_1}} e^{j(k'_u Y_1)} \quad (15) \end{aligned}$$

to yield the 4D REWSA database as

$$\Gamma(t, \tau, u, \nu) = s_{m\omega}(t + \tau, u + \nu) s_{m\omega}^*(t - \tau, u - \nu) \quad (16)$$

where  $s_{m\omega}(t, u)$  is the inverse F'T of  $S_{m\omega}(\omega, k_u)$  evaluated at offsets,  $\tau$ , a temporal lag variable, and  $\nu$ , a spatial lag variable. Hence, a new four

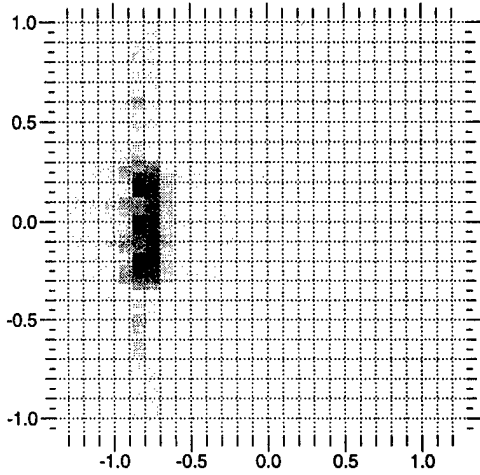


Figure 6: Synthetic Aperture image formed under RMS motion  $\sigma_x = 1mm$

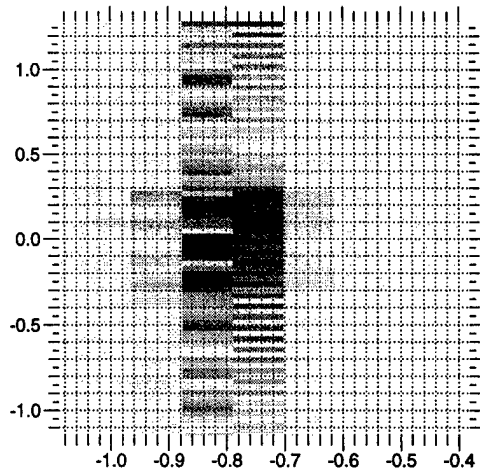


Figure 7: Synthetic Aperture image formed under RMS motion  $\sigma_x = 3mm$

dimensional data set  $\Gamma(t, \tau, u, \nu)$  is formed from the two dimensional data set of equation 2 (or more accurately its spectral and motion error compensated counterpart, equation 15). The temporal lag variable  $\tau$  is readily formed by selecting time offsets from a function of time  $t$ . Likewise, the spatial lag variable  $\nu$  can be formed through selection of a subset of the along track data (item 8 in figure 4) over spatial variable  $u_i$  with offset  $\nu_j, 0 \leq j \leq N$ , but can also be developed by the simultaneous reception of echoes across a real, physical aperture whose elements are placed at offsets of  $\nu_j$ . Bistatic mode (figure 8) is actually the preferred implementation, but herein we will only summarize the “monostatic” REWSA due to limited space and a simpler derivation.

Performing an inverse FT on both dimensions of  $S_{m\omega}(\omega, k_u)$  (equation 15) yields

$$s_{m\omega}(t, u) =$$

$$\int \int d\omega_1 d\alpha_u \Psi(\alpha_x, \alpha_u) e^{j(\alpha_x \Delta X_1 + \alpha_u Y_1)} e^{j(\alpha_u u + \omega_1 t)} \quad (17)$$

with residual position error  $\Delta X_1 = X_1(u) - \hat{X}_1(u)$ .

$$\Gamma(t, \tau, u, \nu) = \quad (18)$$

$$s_{m\omega}(t + \tau, u + \nu) s_{m\omega}^*(t - \tau, u - \nu) \int d\omega_1 \int d\omega_2 \int d\alpha_u e^{j(\alpha_x \Delta X_1 + \alpha_u Y_1)} \Psi(\alpha_x, \alpha_u) e^{j(\alpha_u (u + \nu) + \omega_1 (t + \tau))} \int d\beta_u e^{-j(\beta_x \Delta X_1 + \beta_u Y_1)} \Psi^*(\beta_x, \beta_u) e^{-j(\beta_u (u - \nu) + \omega_2 (t - \tau))}$$

where temporal frequencies  $\omega_1$  and  $\omega_2$  are base-band quantities, and the two horizontal wavenumbers  $\alpha_x$  and  $\beta_x$  maintain a realistic dependence<sup>1</sup> on the carrier frequency  $\omega_c$  through

$$\alpha_x = \sqrt{\left(\frac{2(\omega_c + \omega_1)}{C}\right)^2 - \alpha_u^2}, \quad (19)$$

<sup>1</sup>The Reduced Wavenumber characteristic will be shown as due to the processing, not the notation.



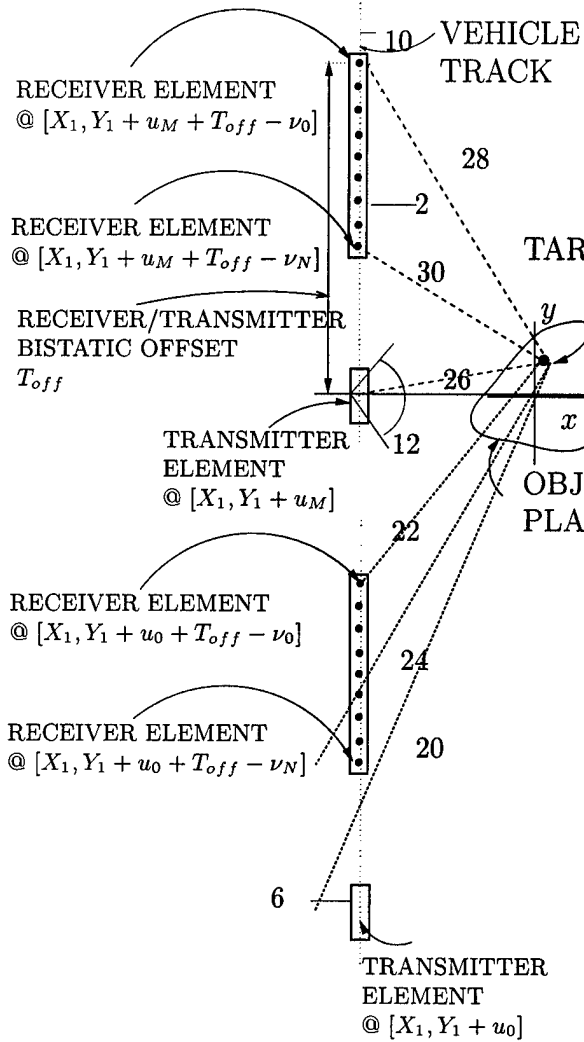


Figure 8: Bistatic REWSA measurement Scenario

$$\beta_x = \sqrt{\left(\frac{2(\omega_c + \omega_2)}{C}\right)^2 - \beta_u^2} \quad (20)$$

The results of the 4D Fourier Transform of  $\Gamma(t, \tau, u, \nu)$

$$FT(\Gamma(w_o, \tau, u, \nu)) \rightarrow \Gamma(w_o, \Theta, k_u, k_\nu) \quad (21)$$

is presented *without development* [Ekh95] as

$$\Gamma(w_o, \Theta, k_u, k_\nu) = e^{jY_1(k_u)} e^{j\Delta X_1(\alpha_x'' - \beta_x'')} * \Psi\left(\alpha_x'', \frac{k_\nu + k_u}{2}\right) \Psi^*\left(\beta_x'', \frac{k_u - k_\nu}{2}\right) \quad (22)$$

TARGET where

$$\alpha_x'' = \sqrt{\left(\frac{(\omega_c + \Theta + \omega_o)}{C}\right)^2 - \left(\frac{k_u + k_\nu}{2}\right)^2} \quad (23)$$

and

$$\beta_x'' = \sqrt{\left(\frac{(\omega_c + \Theta - \omega_o)}{C}\right)^2 - \left(\frac{k_\nu - k_u}{2}\right)^2} \quad (24)$$

where  $w_o, \Theta$  are baseband frequency variables, and  $k_\nu, k_u$  are the transform variables for  $\nu, u$ .

Defining new variables

$$\gamma_x = \frac{\alpha_x'' + \beta_x''}{2} \quad (25)$$

$$\delta_x = \frac{\alpha_x'' - \beta_x''}{2} \quad (26)$$

equation 22 can be recast in the form

$$\gamma(w_o, \Theta, k_u, k_\nu) = e^{jY_1(k_u)} e^{j\Delta X_1(\alpha_x'' - \beta_x'')} * \Psi\left(\frac{\gamma_x + \delta_x}{2}, \frac{k_\nu + k_u}{2}\right) \Psi^*\left(\frac{\gamma_x - \delta_x}{2}, \frac{k_u - k_\nu}{2}\right) \quad (27)$$

With some additional wavenumbers defined as  $k_o = \frac{\omega_o}{C}$  and  $k_\Theta = \frac{\Theta}{C}$ , the Taylor series approximation for  $\gamma_x$  and  $\delta_x$  is

$$\gamma_x \sim 4k_C + 4k_\Theta - \frac{k_u^2 + k_\nu^2}{8k_C} + \dots \quad (28)$$

$$\delta_x \sim 4k_o - \frac{k_\nu k_u}{4k_C} + \dots \quad (29)$$

**2.3.1 Motion Compensation Performance**

The residual phase error that drives the motion compensation problem of equation 27,  $e^{j\Delta x_1(\alpha_x - \beta_x)}$  is now reposed as

$$e^{j2\Delta x_1 \delta_x}, \tag{30}$$

and can be seen to be primarily dependent on  $k_o = \frac{\omega_o}{C}$  and *not*  $k_c = \frac{\omega_c}{C}$ . With  $\omega_o$  the base-band frequency offset, (*max*( $\omega_o$ )) defined as the half bandwidth of the system (*BW*), and  $\omega_c$  the carrier frequency, the REWSA process has reduced the overall system sensitivity to residual position error by a factor of  $\frac{\omega_c}{2BW}$  or the *Q* of the system. Moreover,  $\delta_x$  only reaches its maximum value (and hence the system's motion sensitivity) at the fringes of ( $k_o, k_\nu, k_u$ ) domain. Contrast this with the horizontal wavenumber for SAS In equation 5

$$k_x = \sqrt{4k^2 - k_u^2} \tag{31}$$

Since

$$k = \frac{\omega}{C} = \frac{\omega_c + \omega_o}{C} \tag{32}$$

$k_x$  is primarily dependent on  $k_c$ . This reduced wavenumber characteristic is a significant improvement in the sensitivity of the inversion process to unmodeled vehicle motion and medium induced phase noise.

**2.3.2 Time/Frequency Inversion Procedure**

Correcting for the squint angle phase factor  $e^{jY_1(k_u)}$  and dropping the residual motion error  $e^{j\Delta x_1(\alpha_x'' - \beta_x'')}$  from the notation, we are left with the final wavenumber database

$$\begin{aligned} &\Gamma'(w_o, \Theta, k_u, k_\nu) \\ &= \Psi\left(\frac{\gamma_x + \delta_x}{2}, \frac{k_\nu + k_u}{2}\right) \Psi^*\left(\frac{\gamma_x - \delta_x}{2}, \frac{k_u - k_\nu}{2}\right) \end{aligned} \tag{33}$$

which takes the form of a two frequency (spatial) correlation function in *both* the *x* and *y* dimensions (4 total dimensions). In time/frequency

signal theory a Fourier Transform "diamond" can be formed from the Wigner, Ambiguity, two time correlation and two frequency correlation representations of a signal [Tre71]; Depending on the support of the data taken, any one form can be calculated from any other. In the present application, the target reflectivity function  $\alpha(x, y)$  is obtained by derived the two (time/space) correlation for each dimension *x* and *y* by back-transforming  $\Gamma'(w_o, \Theta, k_u, k_\nu)$  and evaluated along a diagonal (actually a plane in 4D space) that yields a functional equivalent to  $\alpha(x, y)$ . The results of this REWSA inversion are displayed in Figures 9, 10 and 11. for the cases of 0,30 and 99 mm respectively. Some points to emphasize:

- The REWSA algorithm maintains a significantly higher robustness against across track motion than SAS; The case of figure 10 (REWSA) has *ten times* the RMS motion of figure 7 (SAS). Even in the case of figure 11 (REWSA) which has *three hundred times* the RMS motion of figure 7 (SAS), there is still some coherence.
- The broader across track resolution was due to a limited frequency domain support. The increased dimensions of the REWSA database and inversion placed a premium on computer memory that we will solve with increase RAM and some programming efficiencies.

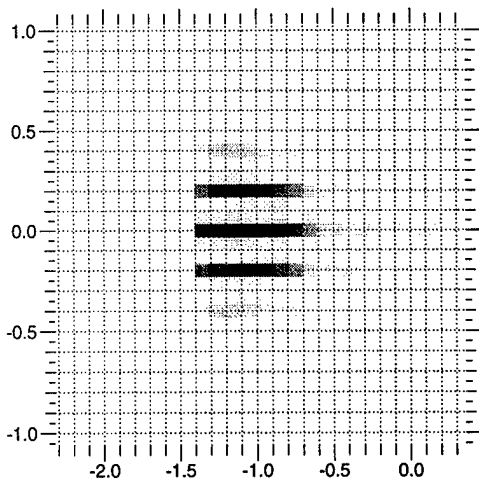


Figure 9: REWSA 3pt Target Estimate @ 0.00 m (RMS) motion

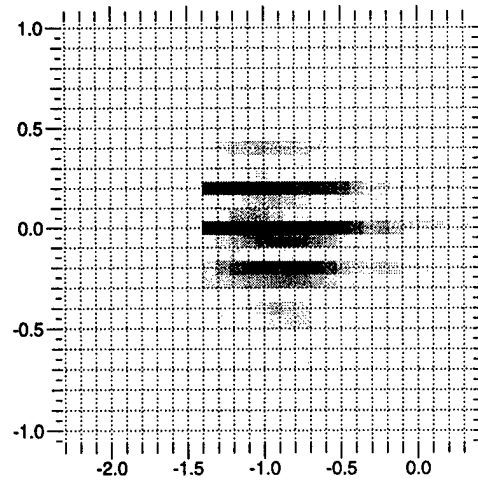


Figure 11: REWSA 3pt Target Estimate @ 0.99m (RMS) motion

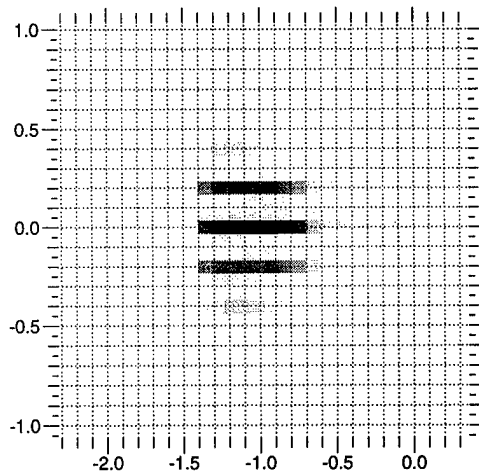


Figure 10: REWSA 3pt Target Estimate @ 0.03m (RMS) motion

temporal/spatial variations in sound speed profile (SSP) manifest themselves as multiplicative phase noise that has prevented operational deployment of existing designs.

The theoretical basis for SAS is presented and it is shown that a key difficulty with existing SAS designs relates to the horizontal wavenumber characteristic to high frequency systems. A unique algorithm for SAS, the Reduced Wavenumber Aperture Synthetic Aperture (REWSA) algorithm is defined as an interferometric means to reduce this wavenumber. The theory behind REWSA is summarized and contrasted with SAS, and it is shown how an inherent robust to the effects of the sonar environment and vehicle motion can, through processing means, be achieved by reducing the effective horizontal wavenumber of the system.

### 3 Summary

In this paper we have discussed the requirement for higher performance in future MCM system designs. While Synthetic aperture sonar (SAS) techniques can theoretically provide unprecedented detection and discrimination performance through very high spatial resolution, the real world issues of residual platform motion and

### References

[B. 93] B. D. Huxtable and E.M. Geyer. Motion compensation feasibility for high resolution synthetic aperture sonar . *OCEANS '93 (Proceedings, 1, 1993.*

- [BFWW87] D. Blacknell, A. Freeman, R. White, and J. Wood. The Prediction Of Geometric Distortions In Airborne Synthetic Aperture Radar Imagery From Autofocus Measurements. *IEEE Transactions on Geoscience and Remote Sensing*, 25(11):775, Nov 1987.
- [Bru92] Michael P. Bruce. A processing requirement and resolution capability comparison of side-scan and synthetic-aperture sonars. *IEEE Journal of Oceanic Engineering*, 17(1):106-117, Jan 1992.
- [Chr90] James Christoff. Synthetic Aperture Sonar for the MADOM project (U), (Confidential). *Journal of Underwater Acoustics*, 40(confidential)(1):651-666, 1990.
- [Dan95] Dan J Ramsdale and J stephen Stanic and Edgar T Kennedy and Roger W. Meredith. High-Frequency Environmental Acoustics Research for Mine Countermeasures. Technical report, Naval Research Laboratory (NRL-SSC), 1995.
- [Ekh95] Ira Ekhaus. Reduced WaveNumber Synthetic Aperture . Technical report, Synap Corporation, June 1995.
- [HG92] Michael P. Hayes and Peter T. Gough. Broadband synthetic aperture sonar. *IEEE Journal of Oceanic Engineering*, 17(1):80-94, Jan 1992.
- [IS79] Osama Ikeda and Takuso Sato. Synthetic Aperture Sonar In Turbulent Media. *Journal of the Acoustical Society of America*, 66(1):209-218, 1979.
- [IS80] Osama Ikeda and Takuso Sato. Further Examination of Synthetic Aperture Sonar in Turbulent Media. *Journal of the Acoustical Society of America*, 68(2):516-522, 1980.
- [ISMF85] Osama Ikeda, Takuso Sato, Yasuo Minamide, and Akira Fukushima. Image Reconstruction From Disturbed Synthetic Aperture Sonar Data Using Aperture Division. *Journal of the Acoustical Society of America*, 78(1):112-119, 1985.
- [Joh94] John M. Silkaitis and Brett L. Douglas and Hua Lee. A Cascade Algorithm For Estimating And Compensating Motion Error For Synthetic Aperture Sonar Imaging. *Proceedings ICIP (international conference on Imaging Processing)*, 139(1):905-909, 1994.
- [SC92] Mehrdad Soumekh and J. Choi. Phase and Amplitude-Phase Restoration in Synthetic Aperture Radar Imaging. *IEEE Transactions on Image Processing*, 1(4), April 1992.
- [Sou92] Mehrdad Soumekh. A System Model And Inversion For Synthetic Aperture Radar Imaging. *IEEE Transactions on Image Processing*, 1(1), Jan 1992.
- [Tre71] H. L. Van Trees. *Detection, Estimation and Modulation Theory, Part III*. John Wiley and Sons, New York, 1971.



# Mine Burial Experiments in Carbonate Sediments

*Daniel F. Lott  
Naval Research Laboratory*

*Kevin L. Williams and Darrell R. Jackson  
Applied Physics Laboratory: University of Washington*

Abstract -- A multi-national and multi-experiment field test was recently conducted that allowed concurrent mine burial testing in carbonate sediments, west of Key West, FL. These sediments are significant in that these sediments are similar to those found in areas of recent naval operations (i.e., Persian Gulf) and represent the only mainland source of such sediments. The mine burial test explored the feasibility of using acoustic systems, with decorrelation processing, to monitor subtle changes in sediment scour around bottom targets. Additionally, experiments in mine impact burial were conducted. Good correlation between impact burial predictions and field results were obtained for certain target shapes but atypical shapes were not well modeled. Acoustic experiments indicated that the decorrelation monitoring of scour burial has good potential for subsequent mine burial experiments. However, there is a great need for better quantification of scour measurements.

## Introduction

The "From the Sea" naval strategy of 1992 has been revised to reflect current thinking. The so-called "Forward . . . From the Sea" revision stresses littoral warfare but not at a cost to presence and power projection roles (i.e., a forward presence for crisis response).<sup>1</sup> In all these roles, naval forces will be operating in an environment that re-emphasizes an environmental parameter not typically a consideration in the previous blue-water naval orientation. That parameter, the seafloor, seriously complicates naval planning due to its highly variable nature. The seafloor is subject to changes in roughness, composition, and structure -- all varying with time and space. Despite these many disadvantages, the seafloor does confer advantages since it provides a stable location for installing both sensor systems as well as weapons both on or within itself and tends to mask those systems from detection.

With a emphasis in shallow water, mines and Mine Countermeasures (MCM) have

been re-emphasized. Mines have often been an operational component of opposing forces and those mines might be within the water column, on or within the seafloor, or proud of the bottom. Proud mines are those that are less than 25% buried. Beyond 25%, mines are considered buried.<sup>2</sup> Mines on the bottom can be difficult to detect, while buried mines pose a special problem to mine countermeasures forces.

This accepted definition of buried versus a proud mine does not have an acoustic basis and there is a real need to correlate degree of burial with acoustic measurements for a wide variety of environmental conditions and in a controlled experiment. Such information is essential for modeling probability of mine burial as well as estimates of sonar performance.

In February 1995, the Key West Campaign was conducted in waters westward of Key West, Florida. This multinational, multi-experimental trial offered the opportunity to conduct two types of mine burial experiments (impact and scour burial) for which there was an extensive environmental measurements program. The scope of the Key West Campaign has been defined elsewhere.<sup>3</sup> The importance of sediments off Key West lie in their composition. Such sediments are the only source in contiguous U.S. waters that can serve as an analogue for shallow water, tropical, carbonate sediments. These sediments are common in areas of recent naval operations (e.g., the Persian Gulf).

## Experimental Objectives

The objectives of the Key West mine burial experiment resulted from a study of environmental requirements supporting mine warfare<sup>4</sup> as influenced by a more operationally-based effort<sup>5</sup> and were, specifically, to

- (1) assess reverberation correlation statistics against scour burial depth,
- (2) investigate acoustic detectability of sediment changes as scour develops,
- (3) perform impact burial predictions and to compare to experimental results for a variety of mine shapes, sizes, and weights, and
- (4) define the methodologies that will be used in subsequent mine burial experiments.

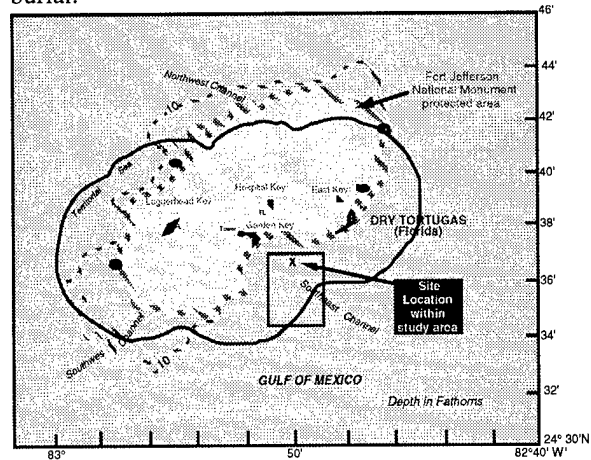
#### Site Description

Mine burial testing was conducted in waters west of Key West, Florida in an area known as the Dry Tortugas test site. It comprised a three by three mile area located in the southeast channel of the Fort Jefferson National Monument protected area. The mine burial tests were conducted at the Dry Tortugas test site centered around position  $24^{\circ} 36.7'N$  and  $82^{\circ} 50.7' W$  (Figure 1). This site was the location of the Applied Physics Laboratory: University of Washington (APL:UW) Benthic Acoustic Measurement System (BAMS) tower.

Because the BAMS site was the primary test area for the Key West Campaign, an extensive sampling program was instituted. Diver sediment cores were taken for photography, x-raying, fine scale electrical resistivity, and various sediment parameters (shear strength, porosity, density, grain size analysis, etc.). Additionally, a number of measurement systems employing in-situ probes were used for measurements of attenuation, shear and compressional wave velocities, and shear modulus. Finally, box cores were taken for studies of biogeochemical processes in the soft, carbonate sediments. Box cores were subsampled for microelectrode studies (resistivity, pH, Eh, and oxygen), pore water fluxes for trace metals and nutrients, organic carbon and nitrogen content, sulfate and sulfide concentrations, microfossils, mineralogy, sediment microfabric, oxygen and carbon dioxide fluxes. These measurements supported studies on sediment structure, efforts independent of the mine burial study.

The test location was selected following a quantitative 100 kHz side scan sonar survey of the Dry Tortugas test site. The BAMS tower

site was located in an area of "apparent" low heterogeneity, composed of a soft, carbonate sediment 2 to 3 m in thickness. For mine burial studies, water depth (25.6 m/84 ft) was beyond that likely to produce water current-induced scour burial.



**Figure 1. Map showing the approximate APL:UW tower location where mine burial experiments were conducted**

The sediment surface at the BAMS tower site showed many features without significant relief (i.e., height differences). The bed roughness was biogenic in origin resulting primarily from shrimp burrows and mounds.<sup>6&7</sup> The sediments's surface was coated by a thin diatom layer easily removed by currents and/or diver activity and the actual interface was water-like within the upper 5 cm. Typical mounds were 6 to 9 cm in diameter and about 3 to 5 cm in height. Occasionally, several mounds coalesced into a larger structure while the sediment itself consisted of a carbonate mud containing various amounts of shell detritus, all of which showed great lateral variability.

Stereo photographs were taken and used for measurements of sediment roughness. Results have been reported in Jackson, et al.<sup>8</sup> However, scattering strengths at 40 kHz were of a medium level and thus consistent with an acoustically soft bottom. Moreover, strengths were patchy with Lambert images showing both acoustically "cold" and "hot" spots within the 50 m scan radius of the tower. The site produced an intermediate rate of decorrelation between successive scans showing a correlation of 0.87 after a 2 day period (a 1.0 is perfect correlation).

The carbonate sediment was extensively characterized. Sediment parameters of interest to mine burial studies are noted in Table 1. A more extensive characterization can be found in Briggs, et al.<sup>9</sup>

For these mine burial studies, a parameter of particular interest was bottom water currents. Bottom currents within the test area were measured with a Marsh-McBirney electromagnetic current meter at a site near the BAMS tower. Measurements were averaged for the period 5 through 25 February 1995 and the analysis by Wright, et al<sup>6</sup>, indicates that currents are dominated by tides which accounts for about 66% of the total variance. Tides have both diurnal and semi-diurnal components in this area showing a predilection for currents to align 27° east of true north. Maximum velocities were usually less than 20 cm/sec (about 0.4 kts) except during an early storm at the test site which drove velocities up to 35 cm/sec. These current velocities are clearly low and insufficient to be a major contributor to mine burial through current induced scour.

**Table 1. Sediment Parameters for the Mine Burial site.**

SedimentParameter	Measurement
Sediment shear strength (psi)	0.82
Density (gm/cm <sup>2</sup> )	1.66
Wet Bulk Density	1.90
Water Content (%)	39.34
Porosity (%)	51.61
Void Ratio	1.07
Sand Content (%)	47.16
Silt Content (%)	42.93
Clay Content (%)	9.91
Sound Velocity (m/sec)	1570.51

**Test Targets**

Five types of test targets were used for the experiment. These represented a variety of typical mine shapes (cylindrical, projectile, & truncated cone), weights, and sizes (Table 2). The MK-36 DST (Destructor) is a MK-80 series aerial bomb modified into a bottom naval mine. For our experiments, the DST did not have retarding fins installed.

**Table 2. Target Specifications and types as used in the mine burial experiment**

Designation	Length (m)	Diameter (m)	Weight (kg)	Orientation (deg)
MK-36 DST	1.60	400	240	300
MK-36	1.70	480	500	180
MK-52	2.25	844	542	ND
It Manta	0.49	980	220	NA
GE Registration	1.70	470	500	270

**Impact Burial Tests**

**General approach:** The general experimental approach was to launch a variety of mine targets allowing them to free-fall through the water column and impact the bottom. Mines were examined by divers for degree of burial after impact as well as orientation. These results are compared to predictions of burial depth made with the Coastal System Station/Defense Scientific Establishment Impact Burial Prediction Model, Program Version: IMPACT25.<sup>10</sup>

Targets were released from about 1.5 m above the water's surface with a horizontal velocity of zero, fell through the water column for the 25.6 m water depth, and impacted the sediment. Immediately following launch, the target was acquired by divers and buoyed to the water's surface. Buoying was deemed essential since the SCUBA divers had limited bottom time and visibility was generally poor. Buoys were attached to targets by a rope harness to a surface float.

Diver observations were made in the following manner every two days from the period 13 through 24 February: Generally, divers did not approach targets closer than 1 to 2 meters. All targets were approached by the diver becoming neutrally buoyant at the bottom and then gently drifting closer to targets using his fingertips as motive power. The diver's flippers were not used in the proximity of targets. Targets were examined for the presence of scour and impact burial. Depending on water visibility, photography was also attempted from both sides and ends of the targets. Additionally, target orientation, attitude, and burial depth/scour pit depth were recorded.



A number of shortcomings with diver measurements were evident, all resulting from an inability to approach the targets. Accuracy in estimates of mine burial suffered because these measurements were made using a hand-held divers compass while suspended about 3 m above the target. Orientation is therefore approximate with an estimated error of +/- 5 degrees. Estimates of scour also suffered since the diver had to use the target dimensions as the "ruler" to estimate scour length, width, and depth. Similar problems resulted during estimates of target inclination.

**Impact Burial Predictions:** Mine impact burial predictions were made using the environmental inputs of Table 3 coupled with the mine specifications of Table 1. The Impact Burial Prediction Model cycled through the air, water, and sediment phases providing a time history of the impact process and yielding estimates of burial depth (m), height protruding (m), area exposed (%), and volume exposed(%).<sup>11</sup> For this study, the concern is solely burial depth and volume exposed.

**Table 3. Environmental inputs used for impact burial predictions**

Water depth: 25.6 m		
Sediment Inputs		
Depth (cm)	Bearing Strength (pa)	Density (gm/m <sup>3</sup> )
1	16000	1530
3	32000	1540
5	47000	1610
7	57000	1640
9	59000	1660
11	60000	1670
14	58000	1670
20	56000	1700
26	57000	1700
31	72000	1700
34	86000	1700
40	112000	1700

Results:

**Diver Observations of Impact Burial with Model Predictions**

Diver observations of impact burial are found in Table 4 along with predictions made using the Impact Burial Prediction Model. From the table, it is seen that the model tends to predict deeper mine burial than that observed. Note that for these predictions, the model assumed that the target impacts the bottom such that its long axis is parallel to the bottom, thus there is great area offering resistance to penetration. Often, this is not the case with mine orientation being highly variable on

contacting the sediment. Thus, there is a potentially a great deal of variability in burial depth. This was found to be true for the Manta, German registration, MK-36 and MK-36(DST) mines. Another reason for the difference between observed and predicted results is the failure of our inputs to match the real world. For example, using a single measured value of some parameter to represent a sediment depth interval, across which there is a change.

**Table 4. Predictions of impact burial combined with diver observations.**

Mine Type	Impact Observations	Assessment	Burial Prediction	
			Depth (cm)	Volume Exposed (%)
Mk - 36 (DST)	nose fully buried, tail resting on surface, flocculant sediment covers nose of mine	<30% burial	14.0	49.0
Mk - 36*	lying inclined about 15' to sediment surface, down into sediment about 3 to 5 cm at tail, nose in water column, flocculant sediment surrounds mine	minimal	15.7	71.0
Mk - 52	mine lies flat in an impact pit of about 10 cm depth	<>20% burial	8.1	95.0
Manta	landed on its side about 1/4 of it buried, turned it right side up and it appeared very light on bottom	minimal	15.7 7.5	64.0 90.0
Registration	target lying flat on bottom, appears to have landed on nose then fell over	none	16.0	70.0

\* This mine was improperly labeled as a MK-42 mine.

Note that two values (15.7 and 7.5 cm) are recorded for burial depth using the Manta mine. The first value (15.7 cm) results from a model prediction using the full operational weight of the mine. This depth of burial was not observed. Support divers indicated that the target weight in water was substantially less than that reported. Thus, the model inputs for target weight was adjusted to one-half of the reported operational weight and the second value of mine burial was predicted that more closely approached that observed. Note that the Manta landed on the seafloor on its side which was totally unexpected due to it's weight, balance, and shape. Because the Manta mine free floods its case on water impact, inconsistent flooding is the more likely explanation for the observed impact orientation. However, further, more rigorously controlled, experiments are necessary with the atypically shaped Manta mine.

In general, the model performed well for cylindrical and projectile-shaped targets within the constraints of a mandated target orientation at the bottom. It did much less well with atypical shapes. The extremes of a vertical or horizontal impact at the bottom is a deficiency that needs to be addressed, perhaps with a Monte Carlo

simulation providing a better, more realistic estimate of mine burial when mine orientation at the bottom is not known.

### Scour Burial Tests

**General Approach:** Following the impact burial experiments, targets were acoustically scanned at twelve hour intervals using the APL:UW Benthic Acoustic Measurement Systems (BAMS). These scans were used (1) to produce images showing the level of correlation of 40 kHz scattering between successive scans and (2) to graph peak scattering levels found for specific targets.

**Acoustic Measurements:** The BAMS tower is an autonomous, bottom-mounted tripod extending 5.3 m above the seafloor and normally operates autonomously. However, for a portion of this deployment, BAMS was cabled to the waters surface. The scan geometry and tower detail are shown in Figure 2. Although the system was operated at both 40 and 300 kHz during this time period, only the 40 kHz data will be considered here. The 40 kHz sonar used a linear FM sweep of 2 ms length and 2 kHz sweep width. Acoustic scans were made twice hourly from the period 10 through 24 February. Angular resolution at 40 kHz was about 5 degrees.

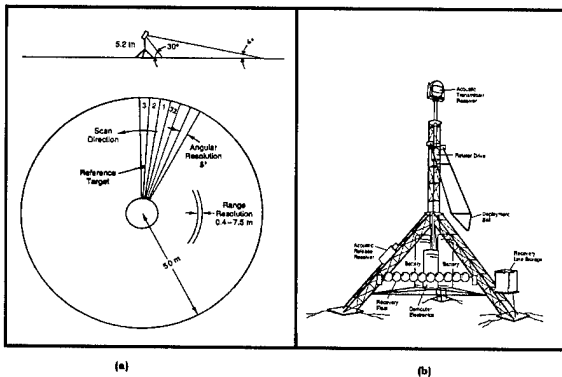


Figure 2. Detail of the BAMS tower and array with (a) scan geometry including resolutions and (b) tower detail

### The Geometry Within the Test Area

The Lambert scattering parameter image for 300 kHz is shown in Figure 3, with true north vertically upward (12 o'clock position). This provides the general geometry within the scanned area. The figure is a single 360 degree

scan of 360 pings, 10 pings per angular step, so that the locations of all visible targets can be shown. Note that the high scattering located central in the image is due to sidelobe scattering near normal incidence from the ocean air and water interface. From the image, about one-half of the available scan area was consumed by the mine targets and bottom experiments while the remainder was used for bottom reverberation measurements. In this composite, the MK-36 (DST) is labeled as MK-82 (MK-82 aerial bomb). The proximity of the MK-36 (DST) to the MK-52 mine caused them to appear as a single target on the majority of scans even when those scans were subjected to match filtering for increase resolution.

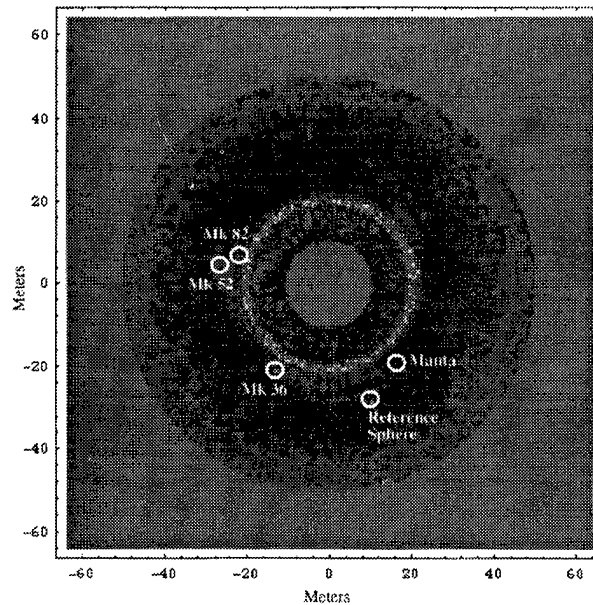


Figure 3. Lambert image at 300 kHz showing the target field geometry

### Results:

#### Diver Observations of Scour

Targets were observed for scour and their observations are found in Table 5.

**Table 5. Diver observations of scour**

Mine Type	Scour Observations			
	Initial	2d observation	3d observation	4th observation
Mk - 36 (DST)	mine fully buried, tail resting on surface in an impact pit. flocculent sediment covers nose of mine and surrounds mine. no observed scour	slight scouring at end of mine extending out about 10 cm and 5 cm deep, nose still covered by loose, white sediment. significant scour at harness location	major scour due to harness significant pit on both sides of mine extending out 50-60 cm and 45-45 cm wide at mine, about 5-8 cm deep	buoy rope trapped under mine, scour due to harness slightly deeper and significant. No change at nose of mine, still covered by flocculent sediment
Mk - 42	buoy inclined about 15-16 sediment surface, down into sediment about 3 to 5 cm at tail, nose in water column, flocculent sediment surrounds mine, no scour observed	scouring at harness location 45-55 cm wide extending out about 20 inches and 15 cm deep at mine, small scour pits forming on all four corners	significant scour due to harness, rope trapped under mine, crab has burrowed under mine creating a cavity 30-35 cm long and 20-25 cm deep	
Mk - 52	no evidence of scour, mines lies flat in impact pit surrounded by a flocculent sediment	small scour pit at both ends and both sides, scour primarily due to harness and buoy rope. its about 45 cm in width extending out about 45 cm and 6-8 cm in depth	little change, majority of scour result from buoy rope and harness, some scour in region of mine plate has removed sediment and a slight pit is developing	
Manta	atypical standing, righted mine and no scour from mine position. Seems very light and movable once friction broken between mine and sediment	buoy has dug into sediment on one side and caused sediment to push up on the opposite side, crabs and burrowing fish have started developing a cavity, not yet significant	no change in appearance, mine is now coated with a thin sediment film, burrowing animals no longer apparent	
Registration	target lying flat on bottom appears to have landed on mine then fell over, scour at nose about 10 cm deep extending out about 45 cm, slight scour at tail on both sides, pit is probably an impact pit rather than scour	pronounced rope marks on aft end of mine with harness caught under mine, scour under aft end limited to just under mine and small, fore end (beveled) has pronounced scour pit that has lengthened and deepened to about 20-25 cm and 15 cm, respectively	scour pit with rope marks on aft end has virtually disappeared, replaced with cavities from crab activity on both sides, some scour due to the buoy harness about 30 cm in width, extending out 45 cm but only 4-6 cm deep on one side only, fore end still has a relatively unchanged pit	relatively unchanged from last observations, harness derived scour is somewhat deeper but not changed in width or extent, crab burrows slightly smaller but have not collapsed

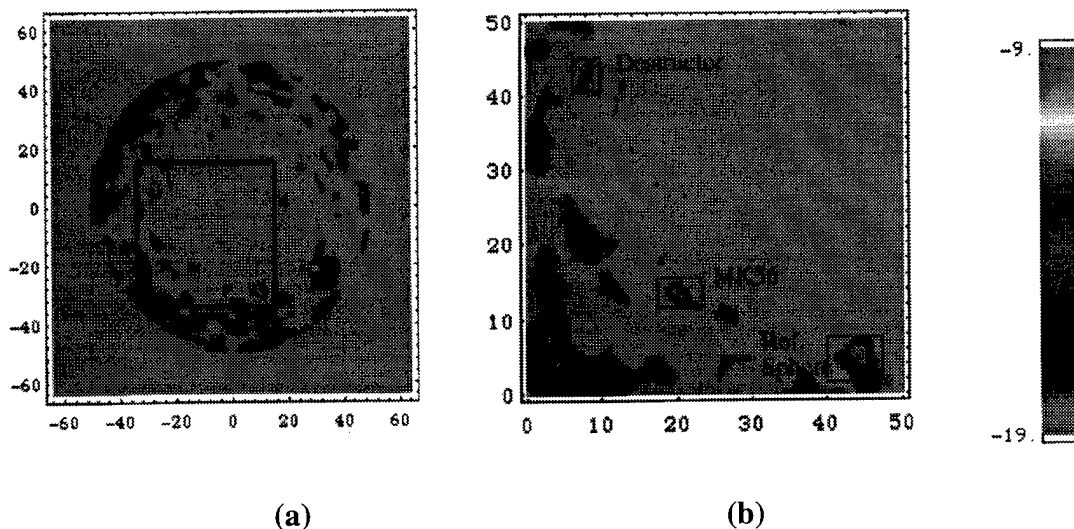
**Acoustic Observations on Scour Burial**

Three types of acoustic data are available. The first (Figure 4) consists of raw acoustic scans and shows scattering in the region of the BAMS tower.

Figure 4(a) is a gray scale image, rendered from the color original, whose signal level has been processed to remove spherical spreading and to remove dependence on incidence angle using a Lambert's law assumption. This

figure shows the entire field of view of the APL tower. The region surrounded by a square is that where the mine targets can be located. A series of eleven images were produced, one per day, that cover the period when targets were in the water. Figure 4(b) shows detail within the area bounded by the square. For this image, the MK-36 (DST) is shown as is the MK-36 sea mine and the reference sphere. At this time, the MK-52 had not been installed. Attached to these images is a color bar whose extremes are represented by -19 to -9 dB range in scattering strength.

Viewing a sequence of eleven images, which are not provided herein, the following notable comments can be made. First, the sphere scattering level changes more than the mines from scan to scan presumably because it was tethered above the bottom about 2 meters and so moves with the current. Second, the MK-36 scattering level has a general rise in scattering strength as a function of time. Finally, the MK-36 (DST)/MK-52 combination yields a fairly consistent scattering level throughout the in-water period. This is true even when regions in the vicinity of targets are expanded so that they can be examined in detail and subject to match field processing to increase resolution.



**Figure 4. Gray Scale Image of Scattering in the region of the BAMS tower with square (a) showing the region containing mine targets and (b) detail of the mine containing region.**

The second type of data are the decorrelation scans between successive Lambert

images. Again, a sequence of images were produced between scans twelve hours apart such

that the second scan in one correlation becomes the first scan for the next correlation. Twenty color images were produced which are not included here. Color images have been rendered in gray scale (Fig 5) representing correlation changes from 1.0 to 0.5 and four images are provided to graphically illustrate the type of information available.

In Figure 5(a), the first scan, clearly seen are the MK-52, Manta, and reference sphere. In Figures 5(b), there is little change in the MK-52 scattering strength; therefore the target does not show up on the figure. The Manta shows but only as a rather indistinct streak which probably represents the Manta moving across the bottom in response to its low in-water weight subject to movement from its surface buoy. The reference sphere shows well, a result of its being deployed above the bottom and subject to water currents.

The sensitivity of the decorrelation studies is shown in Figure 5(c). In this image, divers have constructed a mound and dug a pit on the seafloor and each is discernable as a change between successive scans. Note that the MK-52 mine still does not show and the Manta remains weakly displayed. The reference sphere, in contrast, demonstrates a relatively strong scattering strength and is easily seen

The next and final image shown, Figure 5(d), shows only the reference sphere and a weak indication for the Manta mine. Neither the diver constructed sphere, pit, or MK-52 is visible. Early in the experiment, divers investigated an acoustically "hot" and "cold" spot in order to characterize the scanned area. The acoustically "hot" area was found to be a hole of biological origin populated by finger sponges and was about 2.5 feet in diameter and 1.3 feet in depth at its deepest point. The acoustically cold spot proved to be a layer of softer sediments about 16 inches in depth with low shear strength.

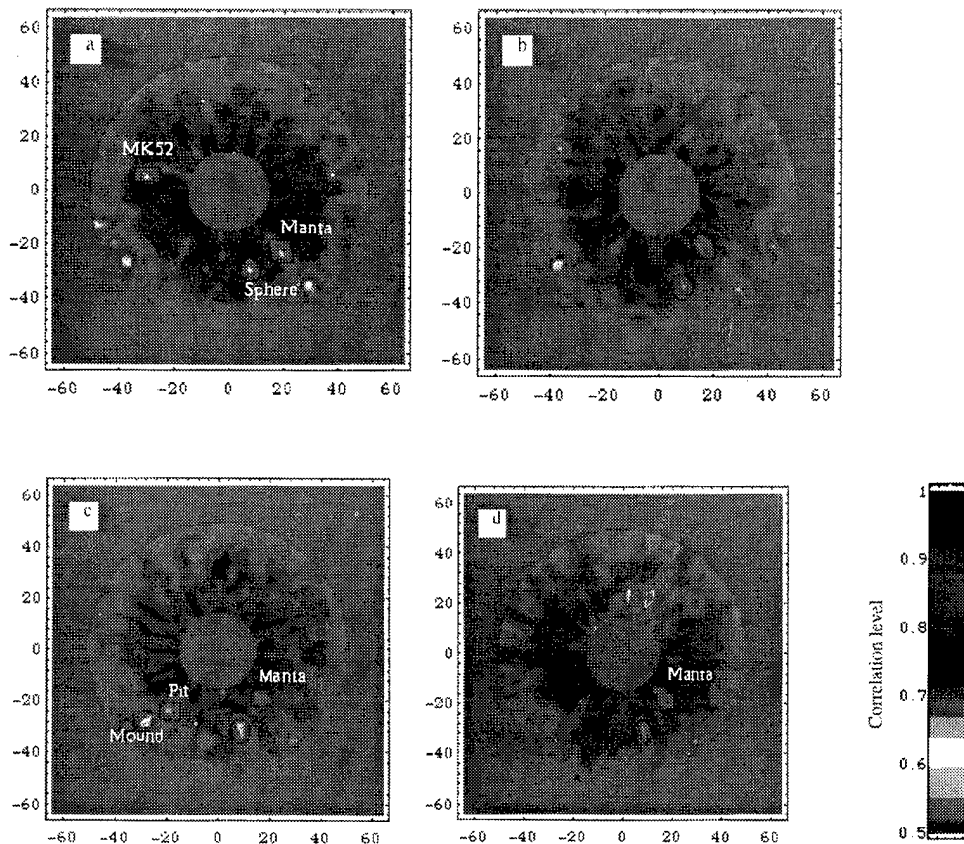
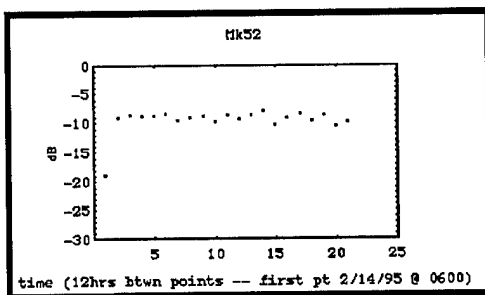


Figure 5. Gray Scale Decorrelation Images

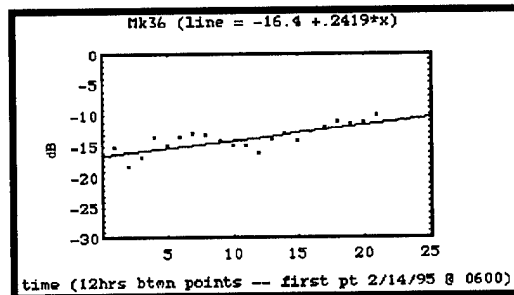
The third data type consists of peak scattering level graphed against time. The scattering levels squoted here were derived by first forming a scattering picture of the entire region around the tower (50 m radius). Remember that the scattering pictures are made by processing the backscattered returns to take out spherical spreading and an assumed Lambert's law dependence on grazing angle. The region in the vicinity of each target was then further examined to determine the peak scattering strength found in the picute for that mine. Note that this process assumes a surface scattering process and the resulting levels for the mines are therefore **not to be interpreted** as their target strength. Note that Figure 6(a) is that for the MK-52

mine, Figure 6(b) is the MK-36 sea mine, and Figure 6(c), the MK-36 (DST). From the figures, it is clear that the MK-52 and MK-36 (DST) show a relatively consistent scattering level throughout the study period while the MK-36 sea mine shows a slow increase throughout. This difference will be discussed somewhat later in this article against the context of diver observations.

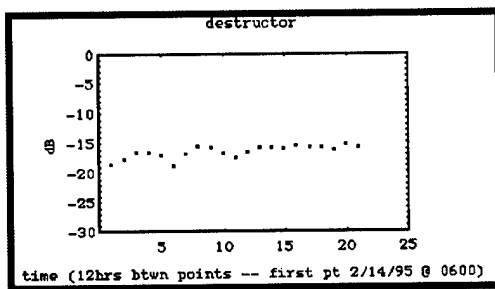
Comparative data for the Manta mine are not available since reverberation values were at or near those shown by the seafloor. Additionally, values for the German registration mine are not available since this target was outside the BAMS scan range.



(a)



(b)



(c)

Figure 6. Peak Scattering Level as extracted from the Lambert Images for (a) MK52, (b) MK36-42, and MK-36 (DST) mines.

Additional Mechanisms of Scour Burial

Diver-derived mine burial results have been presented in Tables 4 and 5. What has not been mentioned is the type(s) of scour produced at the Dry Tortugas site. The normal mechanism of water current-induced scour leading to mine burial was not encountered due to the deep test waters. At this depth, there was insufficient energy to produce scour at the bottom. However, two mechanisms

of scour were observed. The first involved a mechanical scour derived from the harness attached at the mine and cabled to the surface float. This buoying system produced scour in two ways. The first resulted from the harness itself moving primarily in tidal currents but subject to surface wind waves. Typically, a "U" shaped pit would be gouged out to significant depth on both sides near the center of the mine. All these extraneous forces caused the harness to move back and forth creating a pit at mid-center

of the targets. Depth and width of the pit depended on how the mine was laying on the bottom as well as the surface winds and was highly variable.

A second element producing mechanical scour involved the support cable between the harness and surface float. As the tide shifts there is a time of zero net flow then the tide reverses direction and current increases. For this area, tide is oscillatory and thus the cable can be wrapped around and under the targets ends. In some cases, rope strands could be seen incised into the underlying sediment. Note that surface winds play a part in the scour causing a tension in the cable and a bouncing surface float that transmits heave to the mine at the bottom. Because the tide was both oscillatory and rotary, this type of scour could take place at either or both ends.

A second mechanism of scour was biological in origin. Opportunistic sea life (small fish and crabs), taking advantage of the pits initiated by mechanical scour, added additional depth and breath to scour by burrowing extensively below targets. Divers noted significant removal of sand/sediment over a single diver observation period due to a single individual (crab). It is believed that burrowing followed by collapse could be a significant means of promoting scour burial. This contributing mechanism of scour burial was also observed during a second experiment conducted off Panama City, FL about one month after this experiment.

As a final comment, in studies of scour burial, there is a need to isolate targets from mechanical means of scouring when observing for burial by water currents. For our purposes, it was not critical how scour developed, only that it produced change detectable by acoustic methods.

#### Conclusions

Clearly, the information obtained during this experiment is inadequate to fully satisfy the first experimental objective. This objective, of assessing reverberation correlation statistics against scour burial depth, was partially satisfied in that successive acoustic scans could detect changes in reverberation (e.g., movement of the Manta mine). In many environmental situations, such as this environment, scour and mine burial do not necessarily equate. Thus, a more sensitive method of monitoring scour is required that focuses on either volume of material removed, area of disturbance, or perhaps some combination of the two. This experimental objective will not be fully satisfied until additional testing is performed using a more quantitative method of assessing scour and mine burial simultaneously.

Investigating changes in acoustic reverberation as scour develops, the second objective, resulted in some rather interesting results. First, apparent movement of the Manta mine was detected using the decorrelation methods. Possibly what was detected was changes in sediment scattering strength following Manta mine movement which flattened the sediment within its path. Figures 6(a) and 6(c) show a rather constant value of scattering strength for the Mk-52 and MK-36 (DST) mines. These targets did not appear to any great extent within the decorrelation images; that is, there was very little change between successive scans. This is borne out by diver observations. Scour that did develop near these targets developed quickly, usually within a tidal cycle, and remained fairly constant (by visual observation) throughout the in-water period. The same cannot be said for the MK-36 sea mine. Figure 6(b) shows an increasing reverberation which complements diver observations. It is this mine that showed the greatest variation in scour, regardless of how it occurred, during the test period. Further conclusions will require a better method of quantifying scour.

The third objective, that of performing impact burial predictions and comparing to experimental results, was well satisfied for this sediment. The model provides a good estimate of burial depth for cylindrical and projectile-shaped mines. Atypically shaped mines are handled less well. Remember that the better burial prediction in Table 4 above for the Manta mine is an adjusted value that "tricks" the model into assuming the mine is significantly lighter than the weight actually tested. The model essentially treated the mine as a small cylinder with a large diameter. When the full operational weight of the Manta mine is used for predictions, burial depth is estimated to be twice that observed with slightly more than half of the target exposed to detection. This is clearly not the case from diver observations.

The objective for defining the methodologies that will be used in subsequent mine burial experiments was exceeded. Specifically, the experiment indicated that there is a real need for (1) a better method to estimate burial depth and degree of scour rather than diver observations and (2) greater accuracy when determining geometry and/or environmental variables within the test system (i.e., a need for a self-measuring registration mine). It is obvious that mine burial and sonar performance research is handicapped in that the environmental and/or acoustic conditions at the mine location are not known with any degree of accuracy. Obviously, attempts to model mine burial processes have great inherent errors when such parameters are not known. Diver measurements, themselves only a snapshot within a continual mine burial process, are often unreliable and highly inaccurate (since

the diver can not approach the mine without disturbing the burial condition and/or environment). Additional attempts to model conditions important to burial too often rely on environmental measurements taken remote from the actual mine case or from sensors that significantly affect the burial conditions themselves. These are problems which have been verified by this experiment.

Finally, some closing comments can be made including:

- while the test area was selected for its apparent homogeneity, in reality the carbonate sediments were highly variable. Therefore, should the opportunity occur, further experiments in this type of sediment at shallower water depths impacted by strong currents should be done.

- the in-water time for the targets was short considering the low energy situation at the seafloor.

- experiments done in conjunction with an existing field effort means that objectives are structured in terms of "what data can be obtained that is meaningful" rather than "what data is needed". Mine burial testing can be done in joint testing, however, there remains a requirement for specific mine burial testing.

- this effort has shown that there is certainly potential for acoustically detecting and monitoring scour burial; however, follow-on efforts are required.

#### References

1. **George, James L.**, 1995. "Finally, a 'Forward' Naval Strategy". Naval Forces Vol XVI, No III. Pg 6.
2. personal communication, Minutes of the Mine Burial Specialist Team
3. **Tooma, S. and M. Richardson.** "The Key West Campaign". Sea Technology, Jun 1995.
4. **Richardson, M.D. and S.G. Tooma.** "Environmental Requirements to Support Mine Countermeasure Operations in Shallow Water". U.S. Navy Journal of Underwater Acoustics. Vol 43, No. 3. pgs 977 - 991, Jul 1993.
5. **Lott, D.F.** "Recommendations for Improving Performance of MCM-1 Class Ships Though the Use of Environmental Information." NOARL Technical Note 70, dtd Sep 1990.
6. **Wright, L.D.; C.T. Friedrichs; R.A. Gammisch; and D.A. Hepworth,** 1995. Progress and Cruise Report to Naval Research Laboratory Coastal Benthic Boundary Layer SRP". Informal letter report from Virginia Institue of Marine Science undated.
7. **Briggs, Kevin B. and Michael D. Richardson,** 1996. "Small Scale Fluctuations in Acoustic and Physical Properties in Surficial Carbonate Sediments and their Relationship to beoturbation". Submitted to Geomarine Letters.
8. **Jackson, Darrell R.; Kevin B. Briggs; Kevin L. Williams; and Michael D. Richardson,** 1996. "Tests of Models for High Frequency Sea-Floor Backscatter". submitted to IEEE.
9. **Briggs, Kevin B.; Dawn L. Lavoie; Kevin P. Stephens, Michael D. Richardson, and Yoko Furukawa,** 1996. "Physical and Geoacoustic Properties of Sediment Collected for the Key West Campaign". Naval Research Laboratory Memorandum Report 7431-96-8002.
10. **Satkowiak, L.J.** "Modified NCSC Impact Burial Prediction Model with Comparisons to Mine Drop Tests. NCSC TM 486-88. Naval Coastal Systems Center, Panama City, FL. 1991.
11. **Arnone, R.A. and Bowen, L.E.** "Prediction of the Time History Penetration of a Cylinder through the Air-Water-Sediment Phases" NCSC letter Report T34, Naval Coastal Systems Center, Panama City, FL. 1980.

# Buried Target Image Quality

Nicholas P. Chotiros  
Applied Research Laboratories, The University of Texas at Austin  
P.O. Box 8029, Austin, TX 78713-8029  
email: chotiros@arl.utexas.edu

**Abstract- Objects buried in the ocean sediment may be imaged acoustically. Image degradation is caused by propagation and scattering processes. The image quality is expected to be a function of burial depth and grazing angle.**

## I. INTRODUCTION

Buried mines are detectable acoustically, because, in the vast majority of cases, mines are not deeply buried. In sands, they often bury by scouring to a point where the sand just covers the mine. In soft sediments, they bury by impact to a depth determined by the density gradient of the sediment. In either case, the mine is detectable acoustically by sonars operating within the normal range of mine hunting frequencies, although at a reduced range. Experimental observations over the past several decades indicate that acoustic energy penetrates into the ocean sediment. Previous attempts to approximate the ocean sediment as a liquid, or as a viscoelastic solid have been misleading. Sediment acoustic interactions are best understood in the light of Biot's theory<sup>[1]</sup> of acoustic propagation in an elastic porous medium, in which the sediment is treated as a water-saturated porous solid. Therefore, detection is not an insurmountable problem.

The problem is in classification. A mine tethered in the water, or laying on the seabed, may be classified visually or acoustically. Visual classification is often preferred because of the higher quality images. For a buried mine, visual classification is impossible because the sediment is opaque. Acoustic classification through a high resolution sonar remains the most viable avenue. Since sound penetrates the sediment, acoustic classification of a buried mine is possible in principle.

There are two main approaches to acoustic classification. One approach is based on recognition of resonance signatures. The approach considered here is based on imaging. The question that this paper seeks to address is the quality of the image of a buried mine. It is reasonably assumed that the

intervening sediment will have a detrimental effect on the image quality.

The extent to which the intervening sediment will degrade the acoustic image of a buried mine is unknown at present. A large number of physical mechanisms should be considered. Dispersion and signal decorrelation are two mechanisms that may cause blurring, but, due to an almost total lack of experimental information, neither will be considered here. Three mechanisms are considered here. (1) Ghosting: In transmission from water into sediment, more than one type of wave may be generated. Each wave type travels at a different speed and is capable of producing an image. The superposition of images from more than one wave type may cause ghosting. (2) Warping: The water-sediment interface is often rippled, and the sediment itself is often inhomogeneous, causing the acoustic raypaths to be distorted. Their effect is to warp the image. (3) Fogging: Granular sediments, such as sand, have high volume scattering strength. Muddy sediments may have high volume scattering strength due to inclusions, such as gas bubbles. The resulting diffuse scattering generates a background reverberation, analogous to fog in visual images. The result is a degradation of image quality as a function of burial depth and grazing angle. The objective is to develop a capability to quantify these environmental effects on acoustic imaging.

## II. GHOSTING

Ghosting may happen as a result of multipath propagation, or when two or more types of waves, traveling at different speeds, interact with the target. Multipath effects are well understood and may be avoided in most cases. The problem of multiple wave types is less well known. The ocean sediment consists of solid material soaked in sea water. In accordance with Biot's theory, an acoustic wave impinging on the water-sediment interface generates up to three waves in the sediment, two compressional waves and a shear wave; the compressional waves are usually referred to as the



"fast" and "slow" waves. The three waves travel at different speeds.

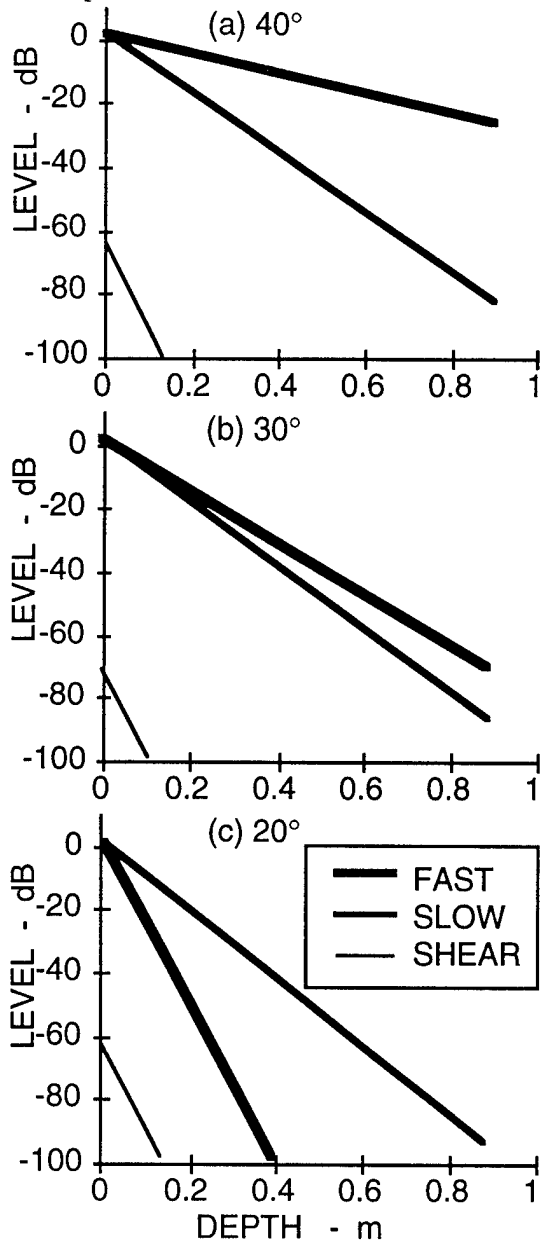


Fig. 1. Acoustic pressure and shear stress levels as a function of depth, at 20 kHz in sand, in response to a 0dB incident acoustic plane wave at grazing angles (a) 40°, (b) 30° and (c) 20°.

In soft muddy sediments, one compressional wave is dominant, and the medium may be approximated as a liquid; a sound wave passing through a water-mud interface is simply refracted.

Ghosting is more likely to occur in a sandy sediment, because it can support all three wave types. Referring to a model of sandy sediments by

Chotiros[2], the relative amplitudes of sediment penetrating fast, slow and shear waves are computed as a function of depth, at selected grazing angles, at a frequency of 20 kHz, as shown in Fig. 1, to illustrate the problem. The model input parameters are from the first column of Table III in reference 2; they represent a sandy sediment found off Panama City, Florida. Referring to Fig. 1(a), the dominant sediment penetrating wave, at a grazing angle of 40°, is the fast wave. The shear wave is at least 60 dB lower than the compressional waves and it may be safely ignored. At depths less than about 0.15 m, there is a possibility of ghosting because the slow wave is only a few decibels less than the fast wave. An image produced by the fast wave may be accompanied by a weaker slow wave image. The fast wave image would arrive earlier than that of the slow wave, producing a trailing ghost image. Referring to Fig. 1(b), at a grazing angle of 30°, the fast and slow wave amplitudes are almost equal, and ghosting is likely at all depths. At 20°, as shown in Fig. 1(c), the slow wave is expected to be stronger than the fast wave, giving a leading ghost image.

There is a further complication because the refraction angles of the fast and slow waves are very different; the two types of waves would strike the target at different angles of attack and are unlikely to be scattered from the same target features. The fast and slow wave images would appear rotated but by different angles, due to the differences in refraction angles. An illustration is shown in Fig. 2, of a rather irregularly shaped target, rather like a wing with a hump running along its center line.

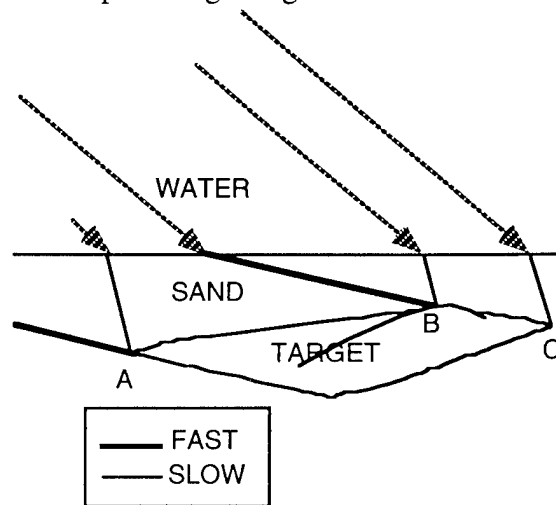


Fig. 2. Illustration of ray paths of fast and slow waves to scattering points of a buried target

In this illustration, the corner C is only visible in the slow wave image; the fast wave raypath to C is blocked by the hump.

### III. WARPING

The water-sediment interface is often rippled due to the action of water currents near the bottom. The apparent refraction angle of sediment penetrating sound rays would be dependent on the local slope at each point on the water-sediment interface, as illustrated in Figs. 3 and 4, in the down- and cross-range planes, respectively. The resulting image would appear warped. The severity of the problem depends on the magnitude of the large scale roughness of the interface. The roughness wave-number spectrum of water-sediment interfaces has been measured at a number of sites by Briggs<sup>[3]</sup>; two sites were chosen, a sandy site referred to as Mission Bay II, and a muddy site, Arafura Sea. Measurements from these sites are used to estimate image warping as an illustration. Let us consider the same target as in the previous illustration, imaged at a grazing angle of  $20^\circ$ .

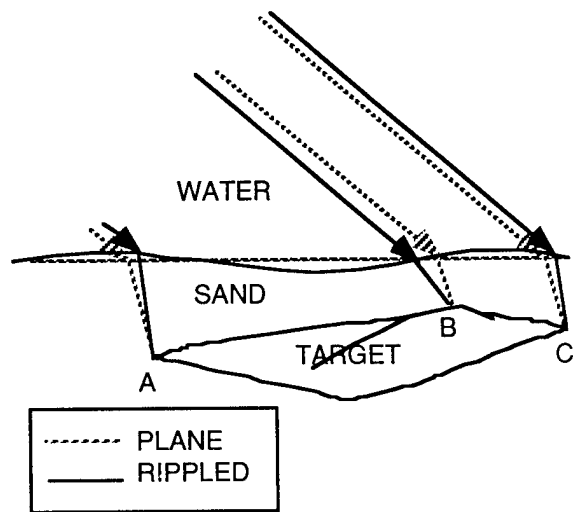


Fig. 3. Illustration of warping in the down-range direction by deflection of raypaths due to ripples in the water-sediment interface

To be realistic, it is also necessary to postulate a sonar that, under ideal conditions, would give images of acceptable resolution at a useful range; let us assume, 10 cm and 500 m, respectively, for resolution and range. For the sake of argument, let us consider a sonar operating at a frequency of 100 kHz, with a bandwidth of 50 kHz, and a horizontal aperture of 20 m. The large aperture is necessary to

achieve the desired resolution at the stated range. How such a large aperture is achieved is outside the scope of this paper. Finally, it is assumed that the sound rays reaching the buried target enter the sediment at a grazing angle of  $20^\circ$ .

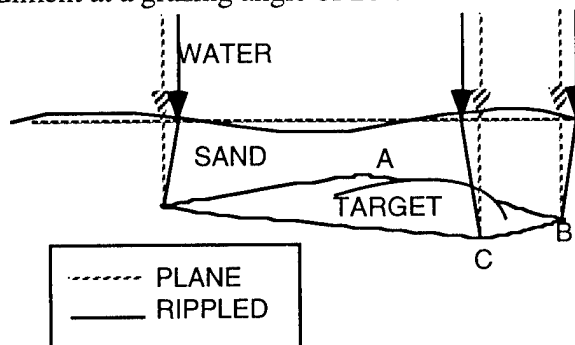


Fig. 4. Illustration of warping in the cross-range direction by deflection of raypaths due to ripples in the water-sediment interface

Using measured wave-number roughness spectrum as input, the surface tilt statistics were computed using methods developed previously for numerical computations of reflection loss from a rough water sediment interface [4]. The roughness may be divided into 2 components, a small scale component which causes a blurring of the image that further degrades the resolution of the sonar, and a large scale component which causes the warping. The predicted warp statistics, in terms of the root-mean-square deviation of the image from its undisturbed condition, are shown in Figs. 5 and 6, as a function of grazing angle, for targets 3 m and 30 cm deep, in the mud and sand sediments, respectively. These burial depths were chosen to give a two-way signal attenuation of about 50 dB at a grazing angle of  $20^\circ$ , which is likely to be the limit for buried target detection and imaging. In the muddy sediment, with a wave speed of 1400 m/s, it is evident that the cross range warp is the larger one, and it is predicted to peak near  $30^\circ$ . In Fig. 6, the results for both the fast and slow waves in sand are shown. The fast and slow wave images are predicted to be dominant above and below the critical grazing angle, respectively; the critical grazing angle is in the region of  $30^\circ$ . For the fast wave (1700 m/s), the down-range warp is predicted to increase rapidly as the critical angle is approached. The slow wave (1100 m/s), which is dominant below the critical angle, is predicted to produce a relatively undistorted image.

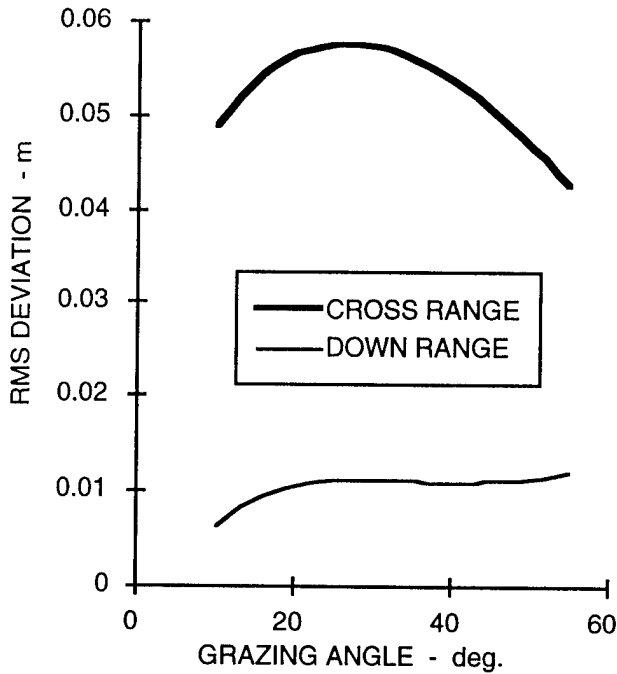


Fig. 5. Estimated image warping statistics of 3 m deep target in a muddy sediment as a function of grazing angle.

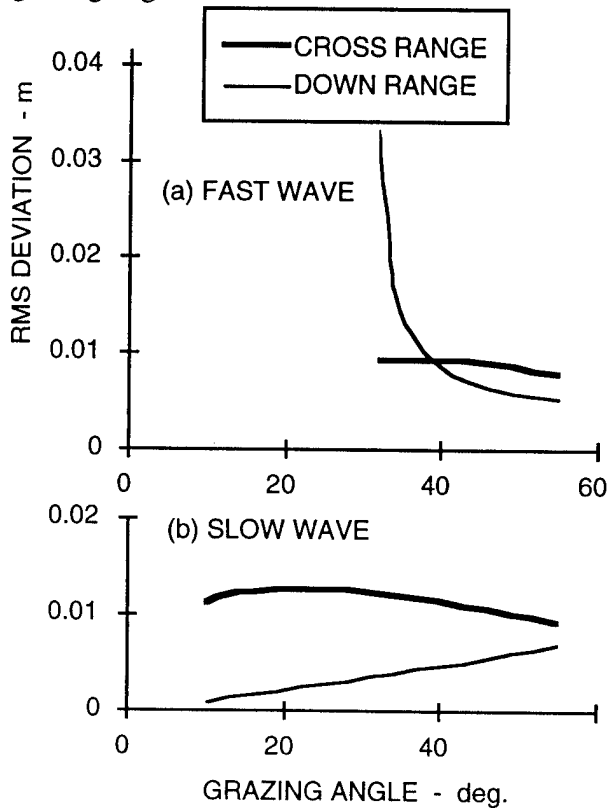


Fig. 6. Estimated image warping statistics of 30 cm deep target in a sandy sediment as a function of grazing angle, for (a) fast and (b) slow wave images.

To illustrate the significance of warping, the statistics were used to realize a warped image of a target buried 3 m deep in the muddy sediment, as shown in Fig. 7. The warped image is shown superimposed on the perfect image. In addition, the resolvable image, due to sonar resolution and the blurring effect of small scale roughness, is shown in the background. It is evident that the warp is small compared to the resolution limits. Only the effects due to surface roughness have been considered. Volume inhomogeneities have not been considered because of a lack of sufficient data.

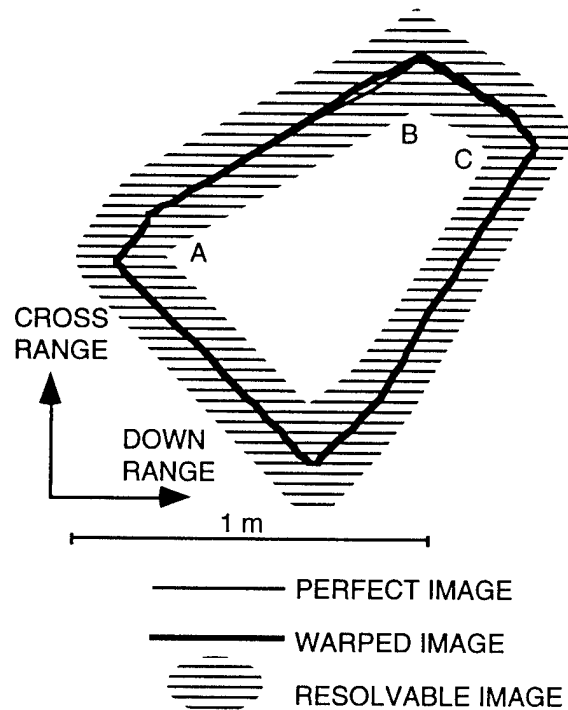


Fig. 7. Illustration of image warping of a target 3m deep in a muddy sediment

#### IV. FOGGING

Image fogging is caused by diffuse volume scattering from the sediment. The mechanism is not well understood. There is some uncertainty regarding the correct scattering theory, i.e. single or multiple scattering. It is likely that in soft muddy sediments, a single-scattering approximation is appropriate because scattering is not intrinsic to the mud, but mainly caused by discrete inclusions. In sandy sediments, multiple scattering may be appropriate because the scattering is intrinsic to the sand grains. The effect is akin to that of fog in optical imagery.

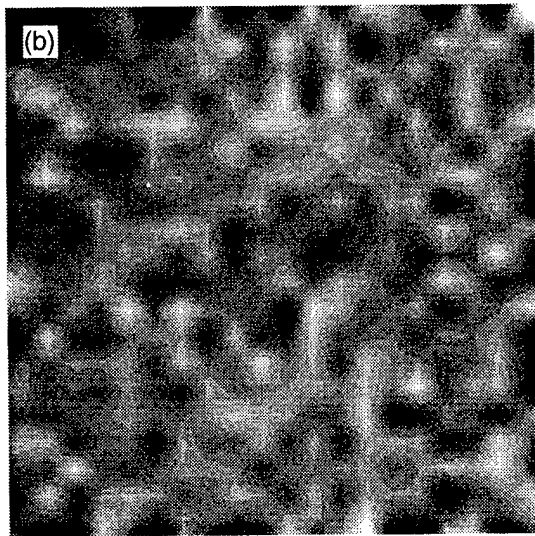
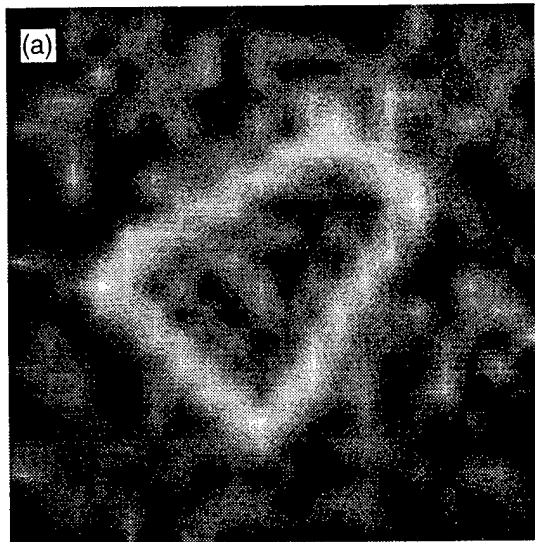


Fig. 8. Image degradation due to fogging in a sandy sediment at depths (a) 3 cm and (b) 15 cm.

An estimate of the fogging problem for a sandy sediment is demonstrated as follows. The net effect of sediment backscattering is expressible in terms of the bottom backscattering strength. A typical value for backscattering strength at  $20^\circ$  may be estimated from the extant database<sup>[5]</sup> of measured values at  $10^\circ$ , ( $BS_{10} = -33$  dB), giving  $BS_{20} = -27$  dB at  $20^\circ$  assuming Lambert's rule. The expected signal-to-backscatter ratio is given by

$$SNR = TS_A - 2TL - 10\log(A) - BS_{20}$$

where  $TS_A$  is the target strength of prominent elements of the target within a sonar resolution cell

of area  $A$ ;  $TL$  is the transmission loss. For this illustration, a reasonable assumption is  $TS_A = -20$  dB along the edge of the target; from Fig. 1(c)  $2TL$  increases with depth at a rate of 170 dB/m.  $A$  is the resolution area of the sonar, assumed to be 10 cm by 10 cm. Using these values, it is computed that a depth of 3 cm gives a SNR value of 23 dB; at 15 cm, the SNR drops to only 3 dB. Assuming a log-normal standard deviation of 5.7 dB in the backscattering<sup>[6]</sup>, a simulation of the fogging effect at these values of SNR is shown in Fig. 8. Somewhere between 3 and 15 cm, the ability to image is lost.

## V. CONCLUSIONS

Of the physical mechanisms that can potentially degrade buried target imaging, three were investigated: ghosting, warping and fogging. From the example calculations in this paper, it is evident that warping is expected to be insignificant. Ghosting is not applicable to soft muddy sediments, but may be a problem in sandy sediments, depending on grazing angle. Fogging, due to backscattering from the sediment, is expected to be the limiting factor. Laboratory experiments are in progress to test these conclusions.

## ACKNOWLEDGMENTS

Thanks are due to Steve Stanic and Dan Ramsdale for encouragement and support.

## REFERENCES

- <sup>1</sup> M. A. Biot, General solutions of the equations of elasticity and consolidation for a porous material. *J. Appl. Mech.* 91-96, March, 1956
- <sup>2</sup> N. P. Chotiros, Biot model of sound propagation in water-saturated sand. *J. Acoust. Soc. Am.* 97(1), 199-214, January 1995
- <sup>3</sup> K. B. Briggs, Microtopographical Roughness of Shallow-Water Continental Shelves. *IEEE J. Oceanic Eng.*, 14(4), 360-367, October 1989
- <sup>4</sup> N. P. Chotiros, Reflection and Reverberation in Normal Incidence Echo-Sounding. *J. Acoust. Soc. Am.* 96(5), 2921-9, November 1994
- <sup>5</sup> N. P. Chotiros and F. A. Boyle, A new high-frequency ocean bottom backscattering model. *J. Acoust. Soc. Am.* Vol. 96, No. 5, Pt. 2, 3264, November 1994
- <sup>6</sup> H. Boehme, et al., Acoustic backscattering from the ocean bottom. Technical Report No. (TR-84-8), Applied Research Laboratories, The University of Texas at Austin, 13 March 1984



**Clutter Sensitivity Test  
Under Controlled Field Conditions**

**Larry Stolarczyk, Sc.D.**  
President, Raton Technology Research  
**Joseph M. Mack**  
Los Alamos National Laboratories

***Resonant Microstrip Patch Antenna  
(RMPA) Sensor Technology***

**Subcontract 0214U0015-3C**

***Prepared for:***

***Department of Defense  
Office of Munitions***

## TABLE OF CONTENTS

EXECUTIVE SUMMARY .....	i
I INTRODUCTION .....	1
II CLUTTER TEST SITE .....	3
2.1 DESCRIPTION OF CLUTTER TEST SITE .....	3
2.2 INTERPRETATION OF MEASURED DATA .....	5
III DESCRIPTION OF CLUTTER TEST RESULTS .....	12
3.1 MEASURED RMPA CONDUCTANCE VERSUS STAND-OFF HEIGHT .....	12
3.2 MEASURED RMPA CONDUCTANCE VERSUS ANTIPERSONNEL LAND MINE BURIAL DEPTH .....	13
3.3 MEASURED RMPA RESPONSE OVER BURIED CLUTTER OBJECTS .....	14
3.4 MEASUREMENT OF RESONANT CONDUCTANCE OVER AP LAND MINES BURIED AT VARIOUS DEPTHS .....	19
3.5 CLUTTER TEST DATA .....	21
3.6 MEASUREMENT OF RESONANT CONDUCTANCE OF THE RMPA SENSOR WHEN SWEPT OVER ANTIPERSONNEL MINE .....	27
3.7 CLUMP OF GRASS .....	31
3.8 AP LAND MINE TILTED AT 45 DEGREES .....	33
3.9 RIVER ROCK .....	34
3.10 MEASUREMENT OF SOIL WATER SATURATION EFFECTS ON MEASURED CONDUCTIVITY .....	35
3.11 ANTIPERSONNEL LAND MINE RESPONSE AT 1700 MHZ .....	37
3.12 MEASURED RMPA RESPONSE OVER RIVER ROCK .....	37
IV CONCLUSION .....	39
5.1 SUMMARY AND RECOMMENDATIONS .....	39

## EXECUTIVE SUMMARY

Theoretical research, controlled laboratory tests, and these field test results show that nonmetallic (and metallic) shallowly buried objects can be detected and imaged with the Resonant Microstrip Patch Antenna (RMPA) sensor. The sensor can be modeled as a high Q cavity which capitalizes on its resonant condition sensitivity to scattered waves from buried objects. When the RMPA sensor is swept over a shallowly buried object, the RMPA fed-point impedance (resistance), measured with a Maxwell bridge, changes by tens of percent. The significant change in unprocessed impedance data can be presented in two-dimensional and three-dimensional graphical displays over the survey area. This forms silhouette images of the objects without the application of computationally intensive data processing algorithms.

Because RMPA employed electromagnetic waves to illuminate the shallowly buried object, a number of questions and issues arise in the decision to fund or deny funding of the reconfiguration of the RMPA technology into a nonmetallic (metallic) land mine detector. Some of the questions are:

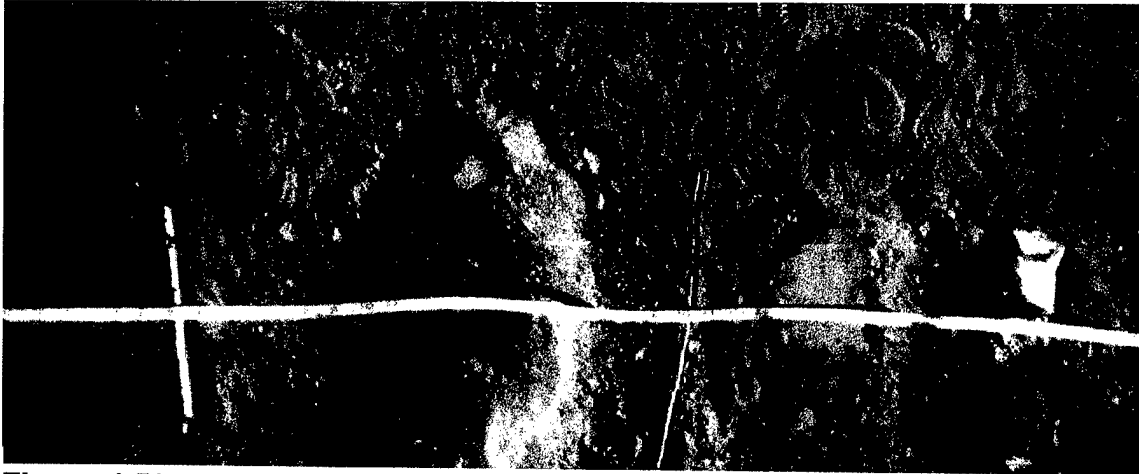
- Can RMPA images distinguish antipersonnel land mines from clutter?
  - How does RMPA detection sensitivity change with the orientation of a buried antipersonnel land mine?
  - How does soil type (clay and magnetite bearing) change the detection sensitivity?
  - What are RMPA's limitations?
  - What are the Probability of Detection (P.D.) and False Positive Rates (F.P.R.) along established lanes?
  - What land mine detection problem does RMPA address?
- and
- Can RMPA technology be reconfigured for humanitarian and battle field environments?

To address these questions and issues, a series of clutter field tests was conducted over lanes of buried objects. The objects included nonmetallic antipersonnel and antivehicular land mines, cultural debris, vegetation, various types of soil, and river rocks.

The questions and issues were addressed by burying clutter objects along with land



mines and measuring the RMPA response. The objects are shown in Figure 1.

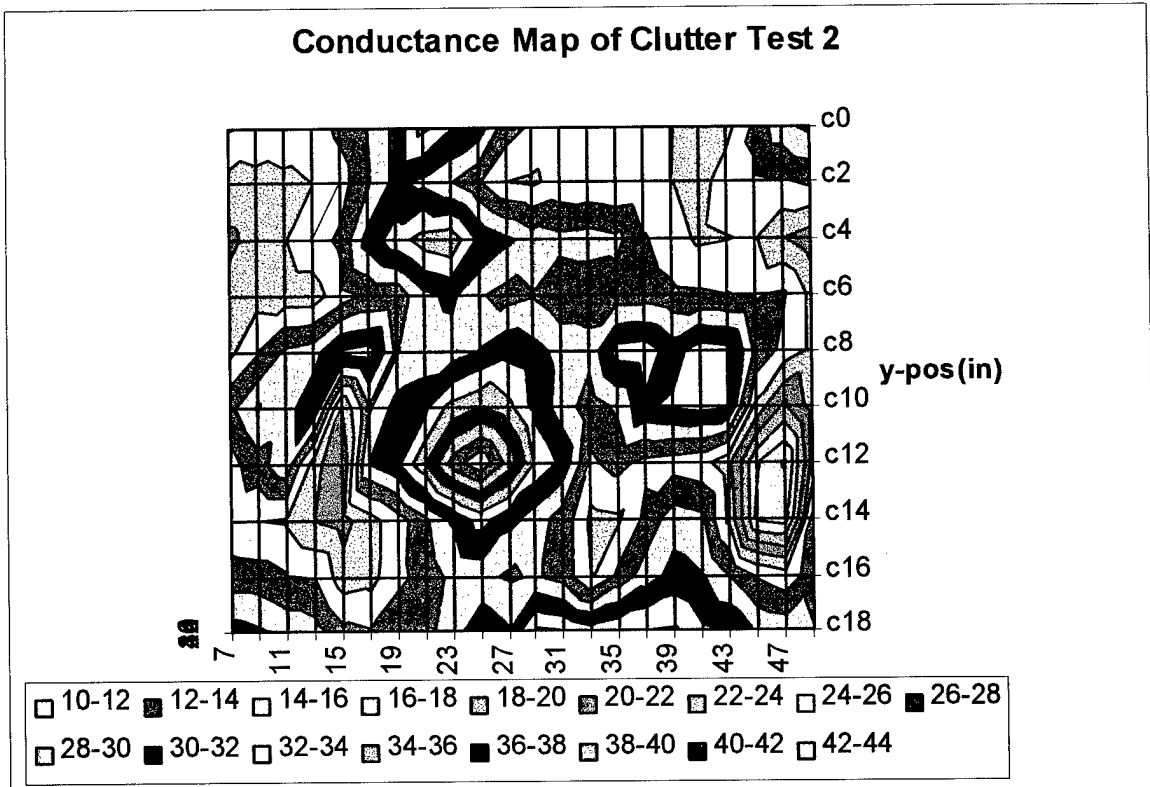


**Figure 1** Photograph of clutter objects, antipersonnel, and antivehicular land mines prior to burial.

Starting at the left side of the photograph and proceeding to the right, the objects are:

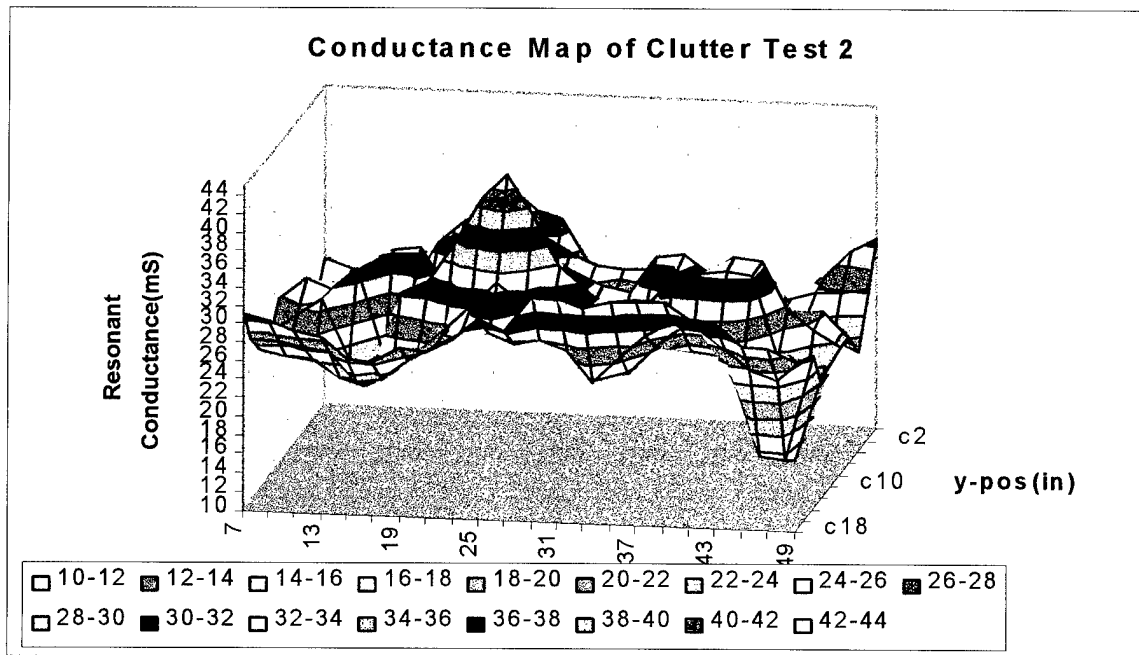
- 3/4 x 8 inch piece of electrical conduit pipe
- constellation of antipersonnel / antivehicular land mines / river rock
- electrical wire
- 2 x 4 inch pine board
- an aluminum beverage can.

The measured conductance (inverse resistance at resonance) values measured over the image plane are illustrated in Figure 2.



**Figure 2** Plan view of measured conductance values over survey area.

The silhouettes of the conduit pipe appear to be eight inches long and the diameter of the antivehicular land mine is near six inches. The diameter of the silhouette of the antipersonnel mine is near three inches. The silhouette of the aluminum beverage can suggests that the object is oblong with a width of two inches and length of three to four inches. All of the silhouettes are reasonably close to the actual size of each of the objects. The river rock and pine board are not evident in the image. A three-dimensional presentation of the measured data is illustrated in Figure 3.



**Figure 3** Survey area map of measured conductance in milisiemens acquired over buried object.

The significant feature in the three-dimensional presentation is that the conductance values decrease over metal objects and increase over nonmetallic objects. This difference may be used in identifying metal and nonmetal objects.

The objects were covered with clay bearing soil. When water was released over the antipersonnel land mine, the detection sensitivity increased. This occurred because the electrical contrast between the soil and the antipersonnel land mine increased.

We find that the detection sensitivity of the antipersonnel land mine changed from 32% to 22% when buried with a 45 degree tilt. This change in sensitivity occurred because the object scatters rather than reflects EM waves. Adding magnetite to the soil did not change the detection sensitivity.

A series of tests was conducted to determine antipersonnel mine detection sensitivity versus burial depth. We found that when antipersonnel mines are buried at the surface, the RMPA impedance decreases (conductance increases) as RMPA approaches and departs from the antipersonnel mine. It reaches a minimum value over the mine. At burial depths of one and two inches, the impedance decreases when RMPA is swept over the antipersonnel mine. The standing wave above the air-soil interface depends on the scattered wave generated by the object. The standing wave also depends on the operating frequency of the RMPA.

Several river rock tests were conducted in clay soil. One inch diameter rocks overlying the land mines increased the detection sensitivity. Tests conducted over river rocks ( $\approx$  two inch diameter) buried at depths of 0, 1, and 2 inches caused the conductance to decrease slightly. Tests over disturbed soil simulating burial at 1 and 2 inches changed the conductance value by a small amount.

### **Limitations:**

The RMPA downward traveling primary wave is phase coherent with the air-soil reflected wave and the scattered wave from the buried object. The vector sum of the waves forms a standing wave above the air-soil interface. The RMPA feed-point impedance appears to be dependent on the standing wave.

We found that the detection sensitivity reaches a maximum value when RMPA is near the air-soil interface and periodically at one-half wavelength intervals above the interface. Minimum detection sensitivity occurs at a quarter wavelength above the air-soil interface. RMPA will be most effective as a close-in man-pack instrument; however, it can also be used with less detection sensitivity in stand-off applications. The stand-off height needs to be controlled or measured in the instrumentation. Designing RMPA with a multifrequency capability would allow the detection sensitivity to be switched from minimum to maximum at any given stand-off height. A multifrequency design would increase the detection sensitivity of the RMPA instrument.

## I INTRODUCTION

Preliminary theoretical studies and controlled laboratory/field tests provided direct evidence that the Resonant Microstrip Patch Antenna (RMPA) could detect and image shallow buried nonmetallic and antipersonnel (AP) land mines. Los Alamos National Laboratories and the NASA Johnson Space Flight Center (electromagnetics branch) participated in the verification and validation. The work focused on antipersonnel land mines because they are more difficult to detect with the current state-of-the-art technologies. NASA used theoretical modeling of electromagnetic (EM) wave propagation at the air-soil interface and experimental measurements to investigate the antipersonnel land mine detection sensitivity. Los Alamos National Laboratories (LANL) used theoretical methods to investigate the physics underlying the RMPA detection process. LANL participated in controlled field experiments to answer specific questions concerning the detection and imaging capability of RMPA. By way of background, the physics of the Resonant Microstrip Patch Antenna (RMPA) sensor is similar to downward-looking radar. RMPA technology capitalizes on its high Q resonant cavity detection process. Both the resonant frequency and impedance (resistance in ohms or conductance in milisiemens) of the high Q resonant cavity significantly change when the RMPA sensor is swept over a buried antipersonnel mine. The resonant parameters are measured at the feed-point of the RMPA sensor with a Maxwell bridge and associated microcomputer-controlled electronics. While the resonant frequency changes by approximately 1%, the resonant impedance changes by tens of percent. The exact change depends upon the operating frequency, burial depth of the object, and the electrical parameters (conductivity [ $\sigma$ ], dielectric constant [ $\epsilon$ ], and permeability [ $\mu$ ]) of the soil and the buried object. The difference in electrical parameters is called contrast. The significant change in resonant impedance when the RMPA sensor is swept over an antipersonnel land mine allows images to be formed directly from unprocessed data. This is important when considering the computational requirements in the identification problem.

Although RMPA technologies reached a mature development status in the real time measurement of uncut coal, its reconfiguration and application in nonmetallic land mine detection needed critical review and consideration. Since RMPA is based upon Electromagnetic wave Detection and Imaging Technologies (EDIT), a number of technical issues must be addressed in the detection and identification of nonmetallic land mines. The probability of detection (P.D.) and False Positive Rate (F.P.R.) are critical performance evaluation factors in humanitarian demining and the battle field environment. Clutter in the form of vegetation, cultural debris, and spent battle field objects have a significant impact on P.D. and F.P.R.. Ideally, the detection system would discriminate against buried clutter objects and detect only land mines. Realistically, it is far better policy to detect every buried object and form images for use in identification. Since image forming is a critical factor in the P.D. and F.P.R. problems, high resolution images must be achieved without computational intensive data processing. The detection system must have a straightforward user interface and be capable of operating beyond the lethal kill distance

limit from a land mine.

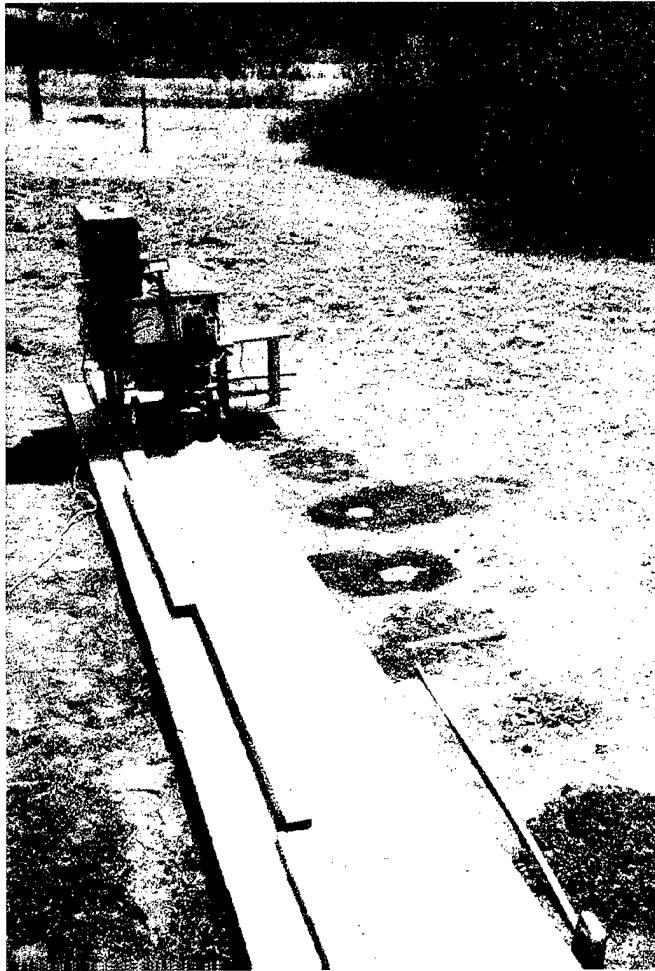
This project addressed the issues and concerns described above by setting up lanes of clutter objects and nonmetallic land mines buried in clay soil. The clutter field tests were designed to enhance our understanding of the detection physics and investigate the limitations of RMPA. Since the RMPA sensor technology is based upon the detection of scattered (not reflected) electromagnetic waves from buried objects, the first series of questions that naturally arises relates to how the scattered wave depends on orientation (scattering cross section) of the land mine, the type of soil (bearing clay or magnetite), moisture, sensor stand-off height above the soil and object burial depth. The next series of tests were concerned with the Probability of Detection (P.D.) and False Alarm Rate (F.A.R.). Can antipersonnel land mines be detected in soil featuring a wide variety of clutter objects? If clutter objects were detected, could they be identified in an image forming process? If image forming is required in the identification process, what is the resolution and computational complexity? What kinds of clutter objects were not detected? Finally, can detection limitations be resolved in the design of the instrumentation and imaging process?

The first series of tests addressed the issue of detection sensitivity versus stand-off height, burial depth and orientation. A mathematical model of the RMPA detection process was developed and found to be in agreement with measured data. This model is useful in qualitatively understanding the relationship of detection sensitivity to stand-off height, burial depth and orientation of the antipersonnel land mine. Our analysis suggests that RMPA resonant frequency and impedance are related to the time average energy density of the standing wave as a function of height above the air-soil interface. The standing wave is caused by the primary EM fields being phase-coherent with the reflected fields from the air-soil interface and the scattered wave from the buried object. The standing wave is periodic in  $\frac{1}{2}$  wave length distance intervals above the soil interface. At 850 MHz, detection sensitivity achieves maximum value when the stand-off height is close to zero and periodically at 6.8 inches (17 cm) intervals. At 850 MHz, the loss tangent of the soil is very small. When the soil is illuminated by the RMPA primary fields, dielectric displacement currents predominate in the soil. Dielectric constant plays a major role while soil conductivity plays only a minor role in determining the intensity of the reflected wave at the air-soil interface at 850 MHz. About 30 percent of the primary field is reflected at the interface. The moisture in the soil causes the dielectric constant to increase. Since the wavelength is 13 inches, it is long compared to the diameter (3 inches) of the antipersonnel land mine; scattering predominates in the detection problem. Scattering causes the orientation of the land mine to be a minimal factor in the detection problem. Orientation would be a significant problem if reflections predominated the EM wave propagation problem in the vicinity of the antipersonnel land mine.

## II CLUTTER TEST SITE

### 2.1 DESCRIPTION OF CLUTTER TEST SITE:

The clutter test site is located on ranch land in the foothills of the Sangre de Cristo Mountains in northern New Mexico. The test site is shown in the photograph shown in Figure 4.



**Figure 4** Instrumentation and survey lane of buried objects.

Nonmetallic land mines and clutter objects were buried along the survey lane. The instrumentation included an HP4191A RF Impedance Analyzer and the resonant Microstrip Patch Antenna (RMPA) sensor. The RMPA was mounted on an extendable wooden boom assembly which could be extended to cause the RMPA sensor to follow a specific Y survey line.

The RF Impedance Analyzer was calibrated at the RMPA feed-point, causing the measurement load plane to be located at the feed-point. This allows the impedance measurements to be made at the RMPA sensor feed-point.

The instrumentation was moved along the travel-way, stopping and measuring at two inch intervals.

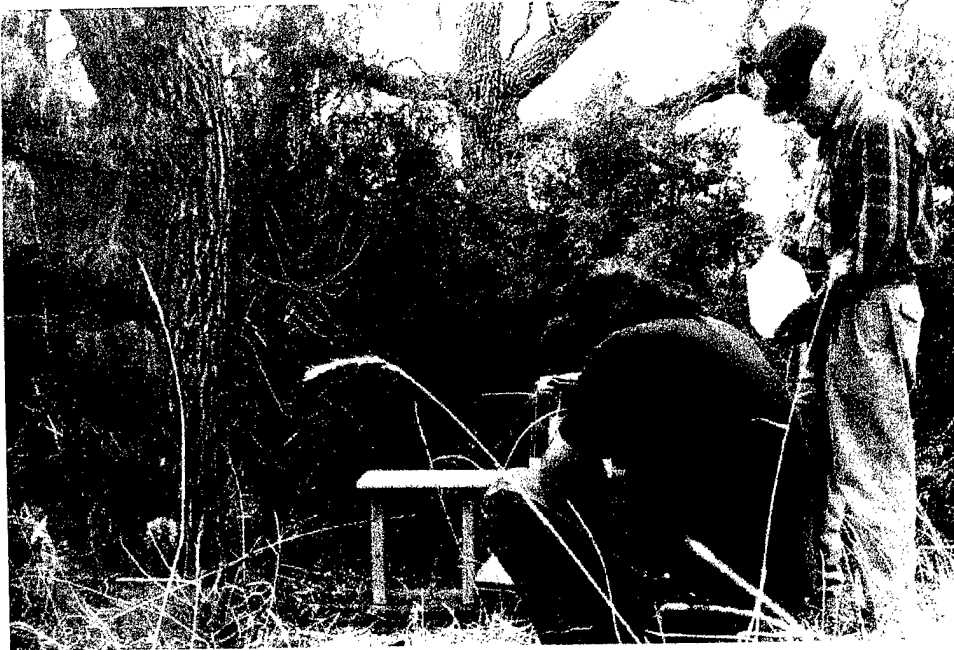
The following buried objects, from back ground to foreground, are shown in the photograph in Figure 4:

- 4" x 4" aluminum plate with a two-inch bracket
- antipersonnel land mine
- 5-inch diameter Lucite cylinder
- antivehicular land mine
- air filled maple syrup bottle
- 3/4 inch diameter plastic pipe
- shell casings
- river rocks.

Clay soil was used to cover the objects in Figure 4. The clay soil was originally the floor of the Cretaceous period sea that covered most of the central part of the United States.

The vegetation tests were conducted next to an oak brush tree illustrated in Figure 5.





**Figure 5** Photograph of the oak brush tree vegetation test.

The tree roots and clumps of grass were in the foreground.

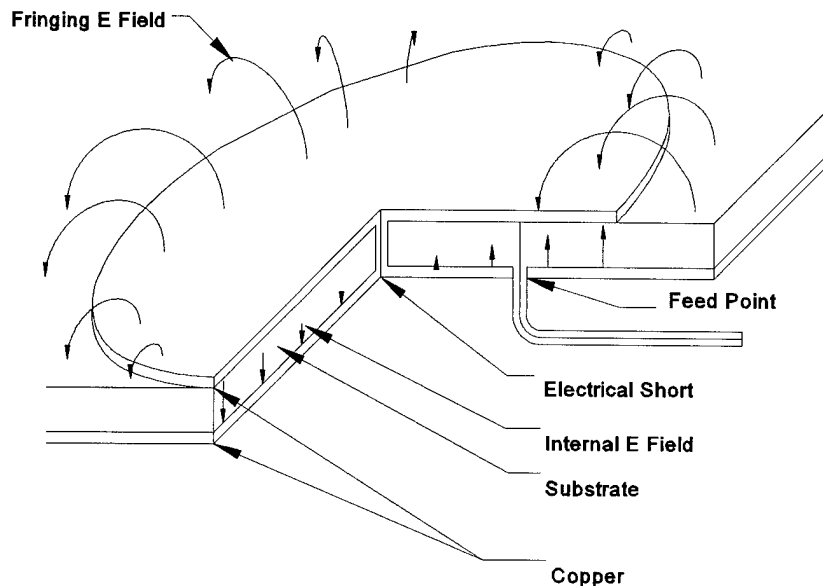
## **2.2 INTERPRETATION OF MEASURED DATA**

Interpretation of electromagnetic wave detection and imaging data is both an art and a science. The science part of the interpretation problem utilizes physics and mathematical formulations to understand how the measured values depend on the electrical parameters of the objects and the surrounding soil. The difference in electrical parameters is called contrast. Modeling will describe how the resonant impedance changes for a wide range of soil parameters and burial depths. The art depends on the skill and training of the countermines personnel.

The RMPA concept was originally formulated by David Chang in his doctoral dissertation at Harvard University under R.W.P. King. Later, Chang and Wait developed the theory which described the admittance variation of a single loop of wire over a layered half space. Their research indicated that a resonant loop of wire could be used in sensing changes in the physical parameters (depth of each layer from the wire loop) and electrical parameters (conductivity  $\{\sigma\}$ , permittivity  $\{\epsilon\}$ , and permeability  $\{\mu\}$ ) of the layers. Chang and Wait also developed analytical expressions for the changes in resonant frequency and input impedance of the wire loop due to changes in the physical and electrical parameter changes of the layers.

Laboratory investigations by Raton Technology Research, Inc. (RTR, Inc.) and

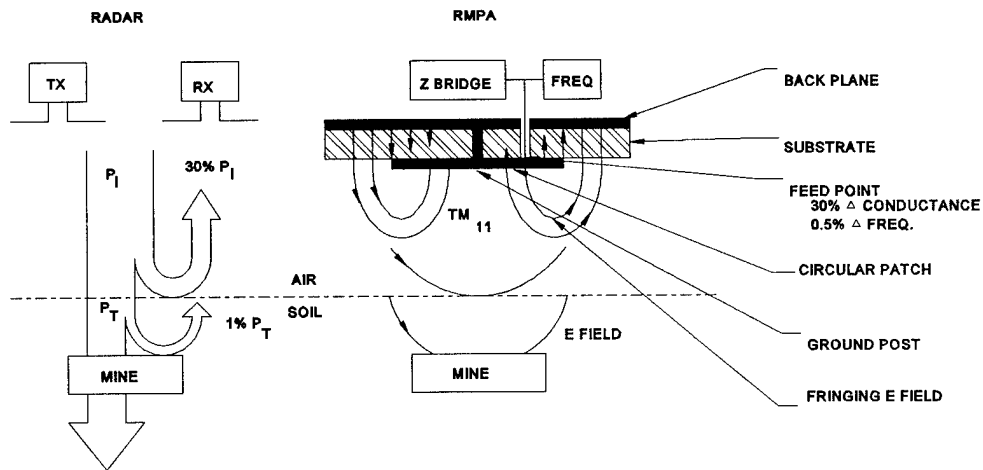
NASA Johnson Space Center, showed that a RMPA exhibited similar resonant frequency and admittance changes as that of the wire loop in the Chang-Wait analysis. The vertical cross section of the RMPA sensor is shown in Figure 6.



**Figure 6** Vertical cross section of the RMPA sensor including the electric field lines.

The RMPA sensor can be modeled as a high Q cavity which capitalizes on its resonant sensitivity, such that a distinct advantage is obtained over a nonresonant EM wave sensor. The high Q cavity is formed by the circular copper patch and the ground plane. The E-field within the cavity is excited/sensed by a vertical “probe” at the feed point. The  $TM_{1,1}$  mode E-field within the cavity and the fringing E-fields are illustrated in Figure 6 above. The magnetic (H) fields are not shown; however, they are orthogonal to the E-fields. The fringing E-fields (and H-fields) play an important part in the RMPA. The fringing EM fields are the coupling mechanisms between the internal cavity fields and external fields. The EM fields between the antenna and the target cannot be characterized solely by near field, induction zone, or far field representations. All three contribute to the RMPA response.

Figure 7 illustrates the physics of the RMPA sensor.



**Figure 7** A cross section of a buried land mine detection problem. For comparison purposes, a GPR system is illustrated on the left and RMPA is illustrated on the right.

In a continuous wave (CW) GPR or RMPA system, the primary field energy propagates downward from the antenna. Approximately 30% of the incident energy is reflected at the soil-air interface.

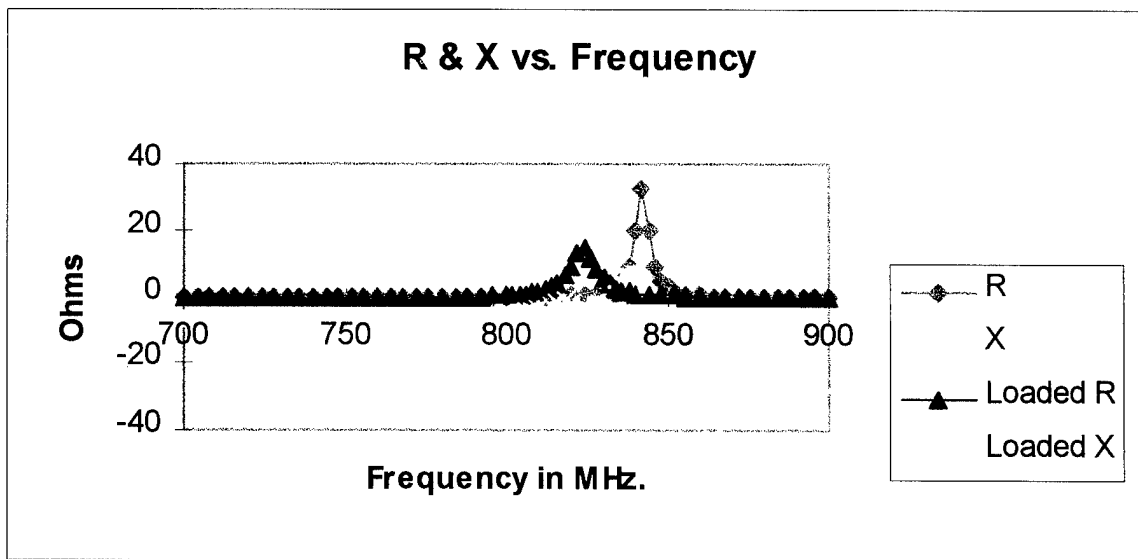
The single high Q RMPA transmits primary EM fields and senses the reflected and scattered fields through its altered resonant condition. A continuous wave is emitted from RMPA that is partly reflected and partly transmitted at the air-soil interface. The transmitted portion of the wave is scattered (not reflected) from the mine due to the discontinuity in conductivity and dielectric constant. The scattered wave is again partly reflected and transmitted at the soil-air interface. Since the primary continuous wave is coherent with the secondary waves, a standing wave occurs in the air space of the soil-air interface.

The return signal to the RMPA serves as an inductive and capacitive mutual coupling between the buried object and the RMPA.

The return signal is coupled through the fringing field and alters the E-field at the feed-point. The RMPA microprocessor-controlled electronics changes the frequency until the measured impedance is real. The resonant impedance measured at the feed point can change by a significant amount when the RMPA is in the presence of a land mine.

GPR relies on a low Q antenna(s) to measure the voltage changes which are proportional to the reflected and scattered fields. Resonant conductance changes at the high Q cavity feed point appear substantially larger than corresponding GPR voltage changes. Therefore, RMPA has a significant increase in sensitivity to scattered fields.

The real (R) and imaginary (X) values of the RMPA feed-point impedance were measured over a range of frequencies with an HP 4191A RF Impedance analyzer. The measured data is presented in Figure 8.



**Figure 8** Measured 850 MHz RMPA sensor feed-point impedance vs. frequency.

The impedance was measured with the RMPA sensor radiating into free space and into soil. The real (R) component (resistance) of the feed-point impedance versus frequency curve illustrates the resonant characteristics of the high Q cavity. The resistance rapidly changes on each side of the resonant frequency. The imaginary component (x) rapidly changes in the neighborhood of resonance.

When the RMPA sensor radiates downward into soil, the resonant frequency and

real/imaginary components of the feed-point impedance change.

The feed-point impedance at resonance depends upon the feed-point radial distance from the center grounding post. The real part of the resonant impedance increases with radial distance from the center.

The feed point resonant frequency and impedance dependence on the electrical parameters have been determined with a commercial software program (Sonnet). A Green's function analysis of the circular patch antenna with multiple layers was also used in modeling. The analytical software programs determined that the resonant frequency and impedance exhibited a damped sinusoidal variation as the sensor stand-off height or burial depth was varied. Studies suggested that the time average energy density of the standing wave closely followed both the modeling and measured data.

The energy density formulation is analytic and provides an insight into the dependence of RMPA measured values on the physical and electrical parameters of the land mine detection problem. The time average energy density is given by:

$$\mu = \frac{Re[E \cdot E^*]}{2} = 1 + R^2 - 2R \cos 2kZ + \frac{2A(1-R)}{\sqrt{\epsilon d + Z}} \cos(2kZ - \sqrt{\epsilon}kd + \Delta) + \frac{2(1-R)A}{\sqrt{\epsilon d + Z}} \cos(\Delta - \sqrt{\epsilon}kd) + \left[ \frac{(1-R)A}{\sqrt{\epsilon d + Z}} \right]^2$$

where  $\epsilon$  = the relative dielectric constant of the soil

$R$  = the soil-air interface reflection coefficient

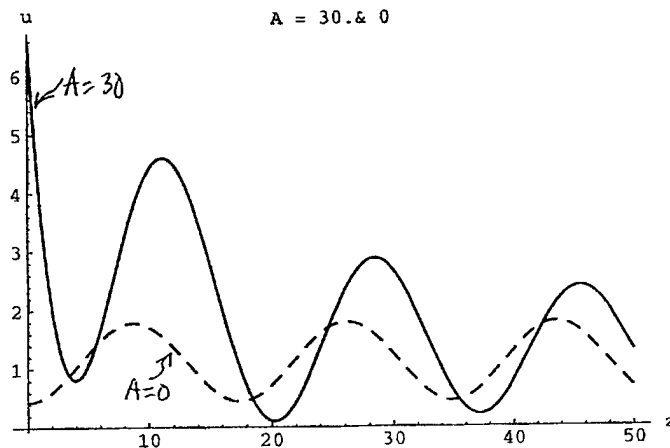
$d$  = the burial depth

$A$  = the scattering amplitude

$k$  = the wave number

and,  $\Delta$  = the scattering phase shift

The energy density versus height above the soil is illustrated in Figure 9.

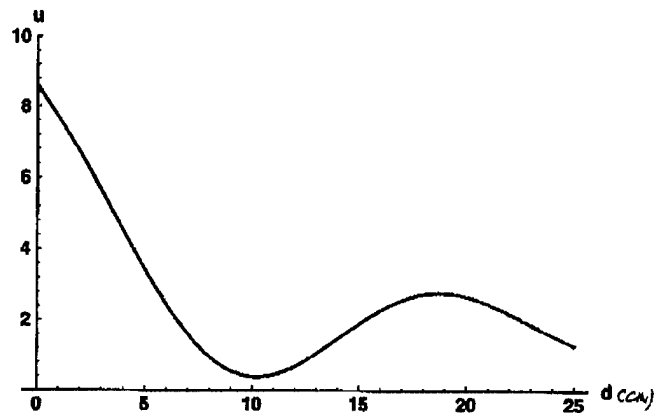


**Figure 9** Energy density versus sensor height above the soil air interface (after Bob Kelly, LANL).

The dashed curve illustrates the energy density without a buried target. ( $A = 0$ ). It illustrates the interference of the incident and soil-air reflected waves. The solid curve is the energy density (system response) as a function of RMPA sensor height above the soil-air interface. The land mine is buried at a depth of 4 cm. The solid curves suggest that the maximum sensitivity occurs when RMPA is in close proximity to the soil-air interface. When the elevation reaches 4 cm, the detection sensitivity would be near zero. The detection sensitivity reaches another maximum near 11 cm.

The energy density also depends upon the burial depth. The period is approximately the wavelength in free space divided by  $\sqrt{\epsilon}$ .

The energy density has been calculated for RMPA sensor heights of 4 cm (1.57 inches) and 11 cm (4.33 inches) above the air-soil interface. The change in energy as a function of burial depth is illustrated in Figure 10 for an antenna height of 4 cm.



**Figure 10** Energy density versus burial depth for an antenna height of 4 cm at a frequency of 850 MHz. The soil relative dielectric constant is assumed to be 4.

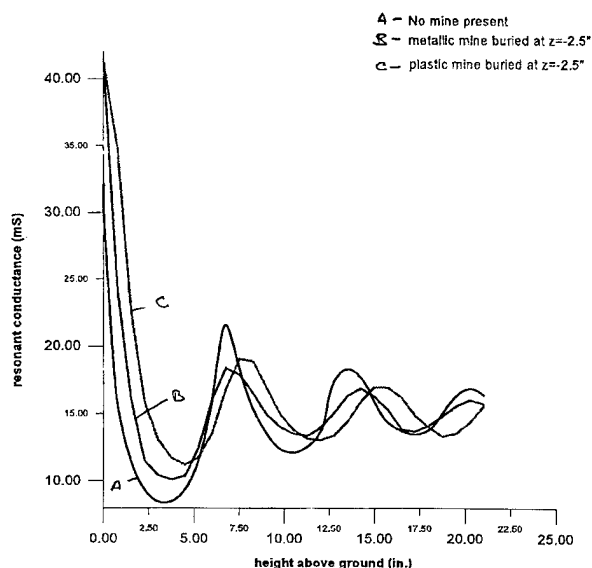
The energy density reaches a minimum value at a burial depth of 10 cm. (3.94 inches). At this depth the resonant impedance reaches a maximum value. As the burial depth increases to 18 cm (7.08 inches) the energy density reaches a maximum value and the impedance reaches a minimum value.

The analytic expression defining RMPA response suggests that a multi frequency system is required. The multi-frequency system would enable the standing wave pattern to change by one fourth wavelength, shifting any minimum response to a maximum response. The phase shift ( $\Delta$ ) used in the analytical expression will be different for nonmetallic and metallic objects. The measured resonant conductance shows that under certain test conditions, the conductance change over nonmetallic land mines is greater than the change over metallic land mines. A system built with multiple-frequencies could capitalize on the change to identify the difference between metallic and nonmetallic objects.

### III DESCRIPTION OF CLUTTER TEST RESULTS

#### 3.1 MEASURED RMPA CONDUCTANCE VERSUS STAND-OFF HEIGHT

The detection sensitivity versus stand-off height is illustrated in Figure 11.



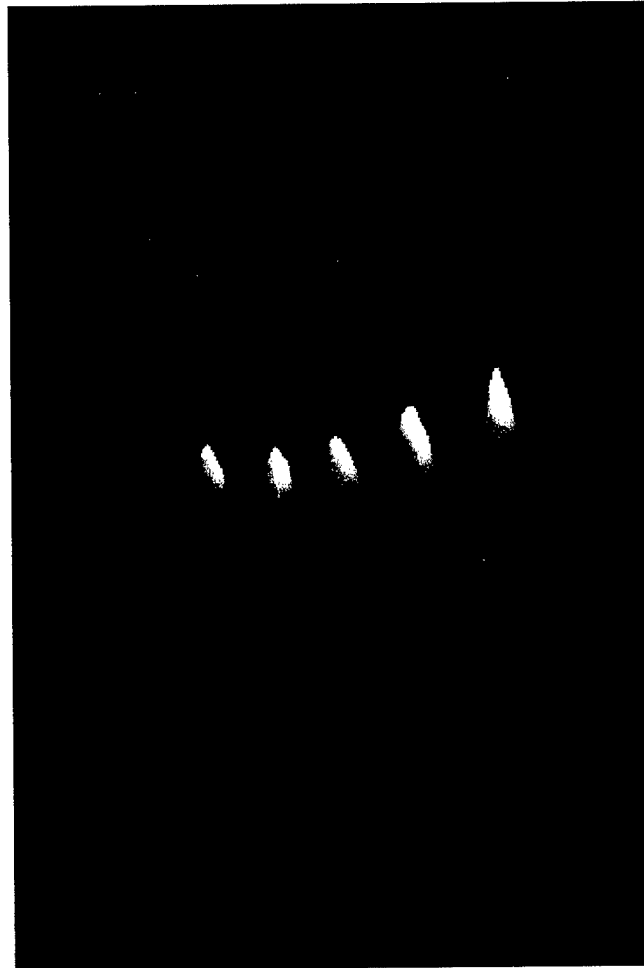
**Figure 11** Resonant conductance in milisiemens versus stand-off height in inches measured over nonmetallic antipersonnel land mine and metal land mine.

These graphs compare the measured resonant conductance data acquired over undisturbed soil with RMPA sensor conductance values measured over nonmetallic and metallic land mines. The sensitivity reaches maximum value when the RMPA sensor is near the soil interface and at half wavelength intervals. At a stand-off height of one inch, the resonant conductance changes from 15 ms to 35 ms, a change of 133%. Because the detection sensitivity reaches a minimum value near a stand-off height of one-quarter wave length, a multi frequency system would ensure that the maximum response is achieved at each measurement location.



### 3.2 MEASURED RMPA CONDUCTANCE VERSUS ANTIPERSONNEL LAND MINE BURIAL DEPTH

The sensitivity of detection versus burial depth was determined by burying antipersonnel mines at depths of 0, 1, 2, 3, and 4 inches. Resonant conductance was measured as the RMPA sensor was swept along survey lines over the survey area.



**Figure 12** Three dimensional image of antipersonnel land mines buried at 0, 1, 2, 3, and 4 inches (left to right).

Conductance data was acquired by sweeping the RMPA along parallel survey lines spaced two inches apart over the survey area. Resonant conductance was measured at two inch intervals along each survey line. The image was formed by taking the absolute value of the difference between measured resonant conductance value and the average

measured conductance value. Silhouettes of the antipersonnel land mines appear in the image.

### 3.3 MEASURED RMPA RESPONSE OVER BURIED CLUTTER OBJECTS

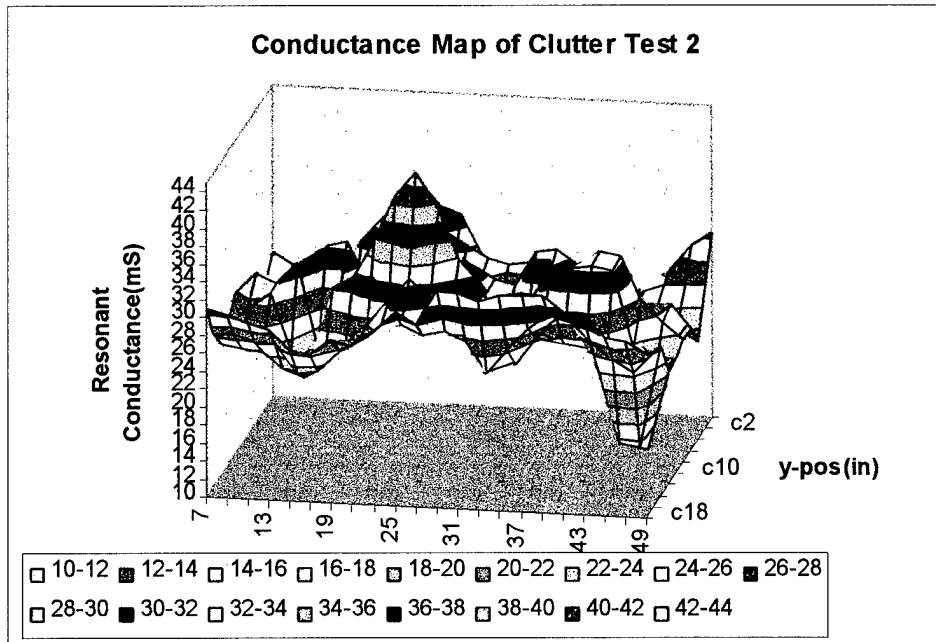
The next series of tests was conducted in a clay soil covering a variety of clutter objects.



**Figure 13** Photograph of clutter objects, antipersonnel, and antivehicular land mines prior to burial.

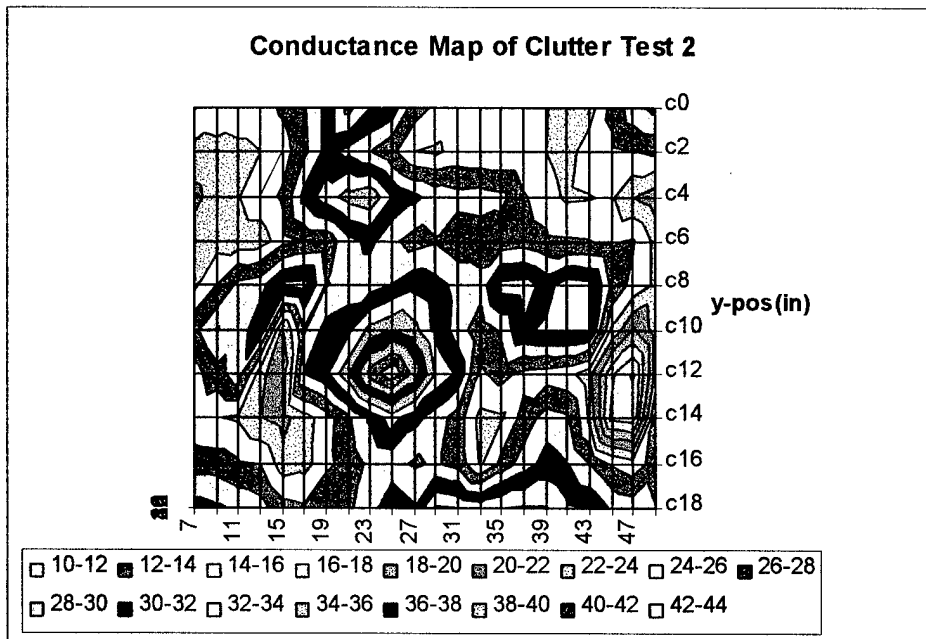
Starting on the left side of the photograph and proceeding to the right, a 3/4 x 8 inch electrical conduit pipe, nonmetallic antivehicular and antipersonnel land mines, river rock, 16 gauge electrical wire, a 2 x 4 x 6 inch pine board, and a 2-inch diameter by 6-inch long aluminum beverage can are shown in the photograph.

Images of the buried objects were formed directly from the measured conductance values.



**Figure 14** Sweep area map of conductance over the buried objects. Measured RMPA conductance values are in milisiemens.

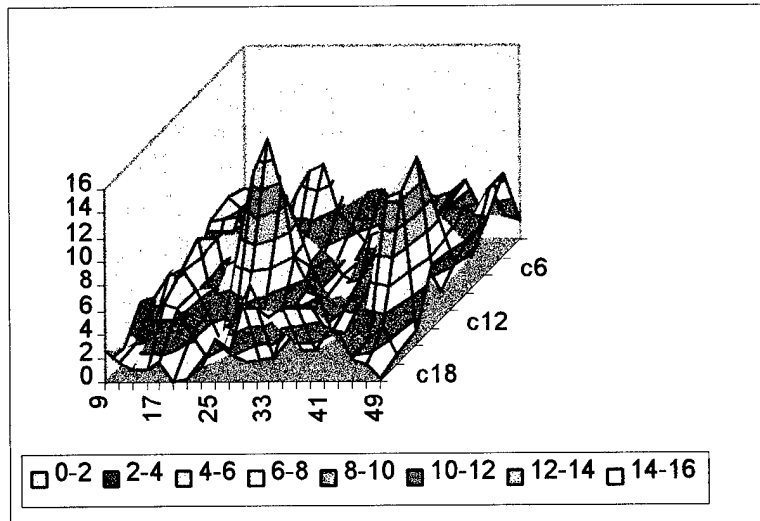
The significant feature in the measured conductance data is that over the metal pipe and beverage can, the conductance values reached minimum values. The conductance values reach maximum over nonmetallic antipersonnel and antivehicular land mines. If significant, this difference may be useful in identifying metal and nonmetal objects. The electrical wire, river rock and 2 x 4 inch board are difficult or impossible to detect in the image. A plan view of the measured data is illustrated in Figure 15.



**Figure 15** Plan view of measured conductance over the sweep area.

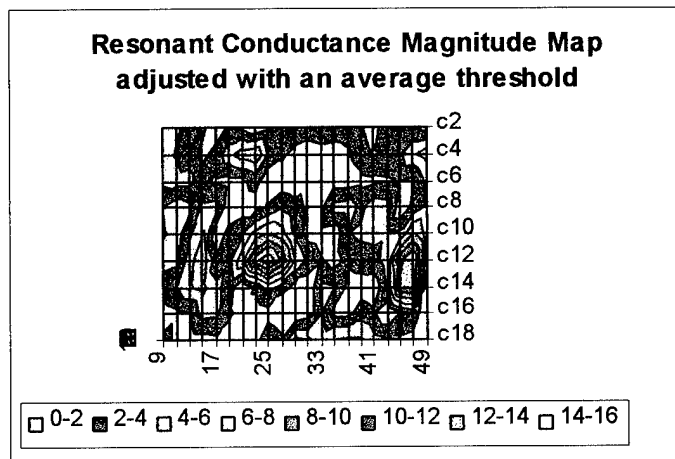
The silhouette of the conduit pipe appears to be near 8 inches long. The diameter of the antivehicular mine is near 6 inches. The antipersonnel mine is near 2 inches (it should be 3 inches). The silhouette of the metal can is rectangular with a diameter of 2 inches.

The measured conductance values shown in Figure 15 were processed by taking the absolute value of the difference between the measured data and the average value of conductance value in the image plane. The image is illustrated in Figure 16.



**Figure 16** Three-dimensional representation of the absolute value of the difference between the measured and average conductance values acquired over the sweep area.

The image of the metal pipe, antipersonnel land mine, and, metal beverage can appear in the formed image. In this image the absolute value processing causes all of the silhouettes to increase in value. Figure 17 shows the plan view of the absolute value of the data.



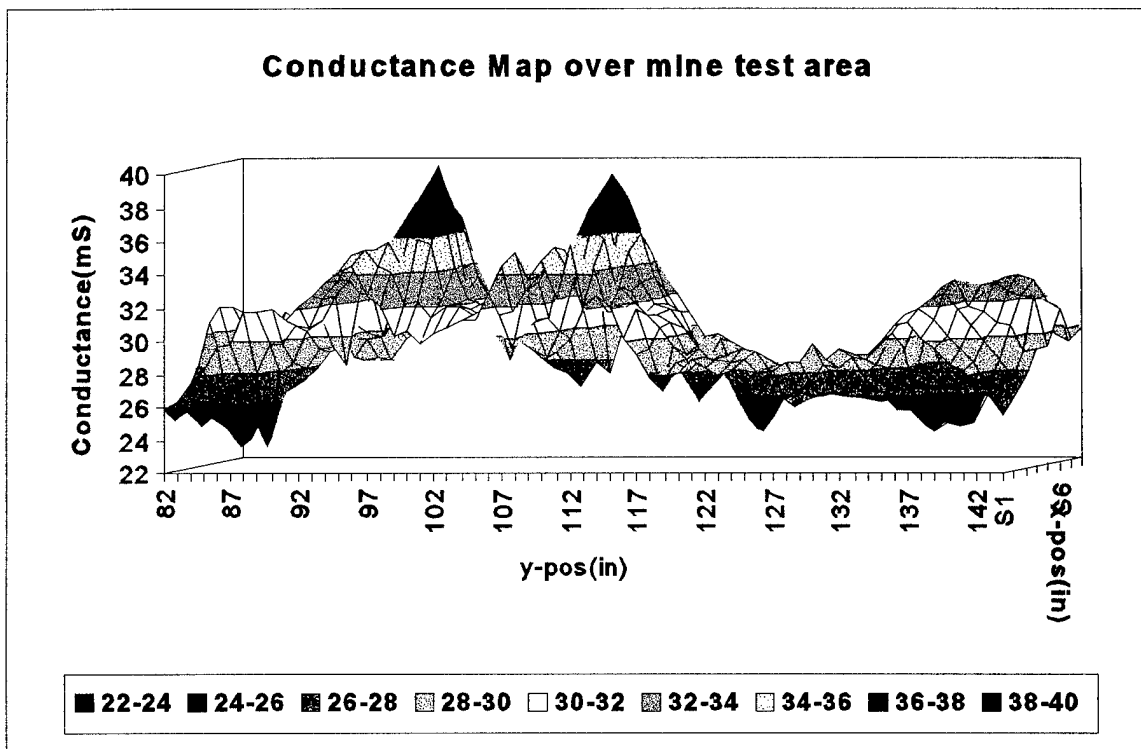
**Figure 17** Plan view of the absolute value data.

A potential false positive detection is seen near the upper right corner of the image,

near C4. The data illustrated in Figure 4 show that a minimum conductance value occurs at this location, which indicates that the false positive is not a nonmetallic antivehicular or antipersonnel mine. Our investigation of the false positive indicated that a soil surface depression occurred at this location. The data presented in Figure 1 confirms the possibility that a sensor stand-off height increase would decrease the measured conductance. This finding suggests that the RMPA instrument design must include a means of measuring sensor stand-off height.

### 3.4 MEASUREMENT OF RESONANT CONDUCTANCE OVER AP LAND MINES BURIED AT VARIOUS DEPTHS.

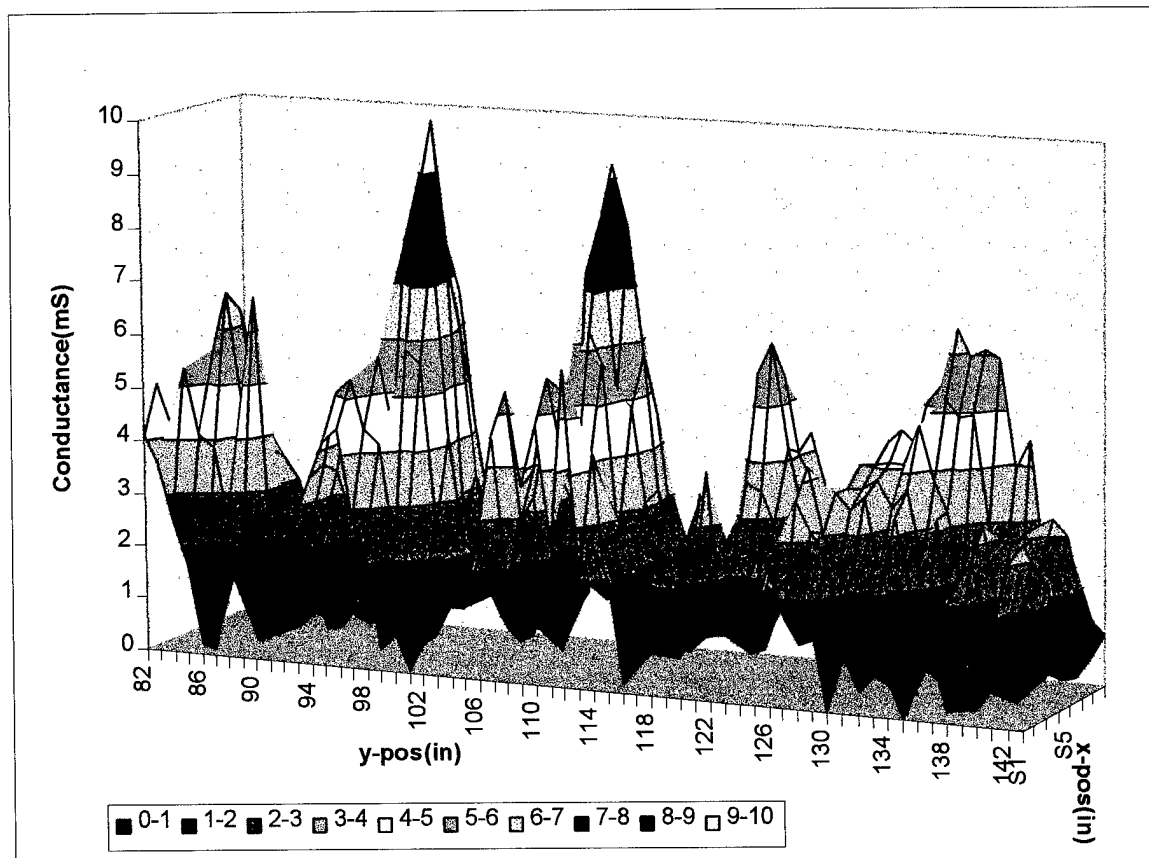
Nonmetallic antipersonnel land mines were buried at depths of 0, 1, 2, 3 and 4 inches. The map of conductance swept over nonmetallic land mines buried at various depths is illustrated in Figure 18.



**Figure 18** Conductance measured over nonmetallic land mines buried at 0, 1, 2, 3, and 4 inches in clay soil.

The first antipersonnel mine is buried at the 86-inch X direction location (burial depth of 0 inches). The conductance value reaches a minimum value at this burial depth and exhibits a double peak. The antipersonnel mine at the 99-inch (burial depth of 1 inch) and the 111-inch locations (burial depth of two inches) exhibit peak measured conductance values of 39 mS. This is a change of approximately 36% over the average value. The AP mine produces a minimum conductance value at a burial depth of three inches. This mine is located at an X location of 122 inches. The AP mine at a burial depth of 4 inches exhibits a maximum value at the X location of 134 inches.

The measured data shown in Figure 18 was processed by subtracting the average measured conductance value (28 mS) from each measured conductance value. The absolute value of the difference is shown in Figure 19.



**Figure 19** Absolute value of the difference in measured conductance and average conductance over the survey area.

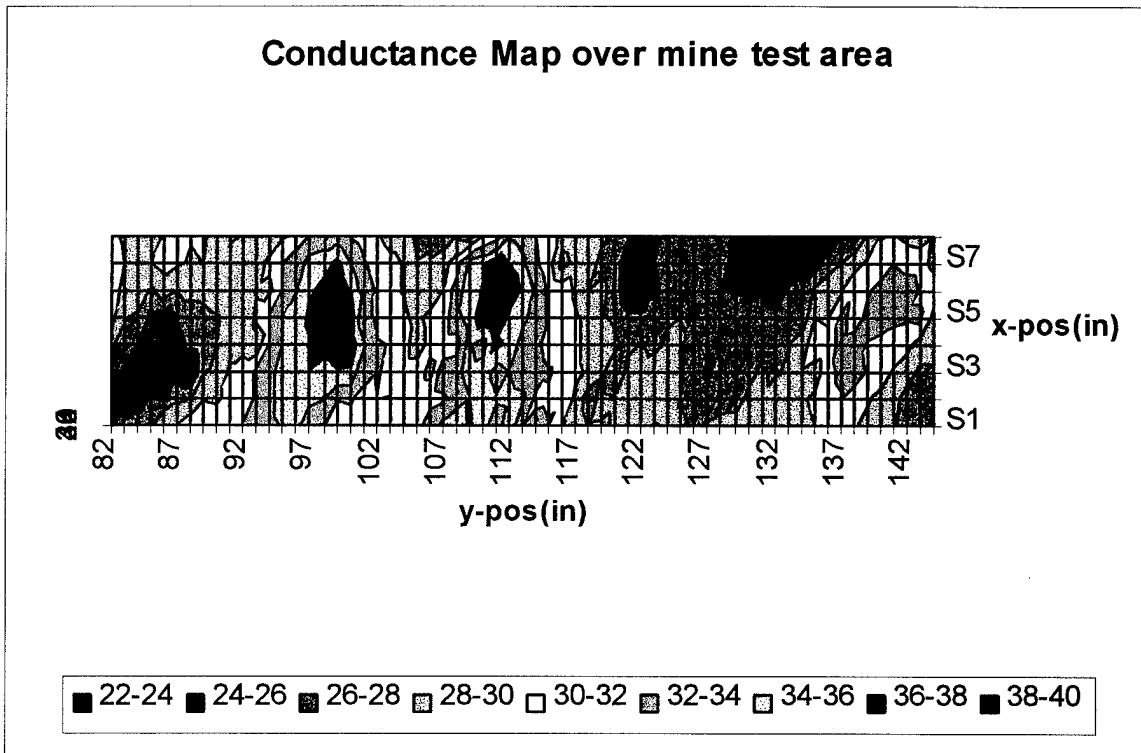
The first antipersonnel mine buried at the ½ inch depth exhibits a double peak. Peak values occur at burial depths of one and 2 inches. Conductance peaks also occur for three and 4 inch burial depths.

The figure 20 illustrates the measured conductance values on the plan view of the image plane.



The AP land mine buried at a depth of ½ inch at the 86-inch X-direction location exhibits a double peak.

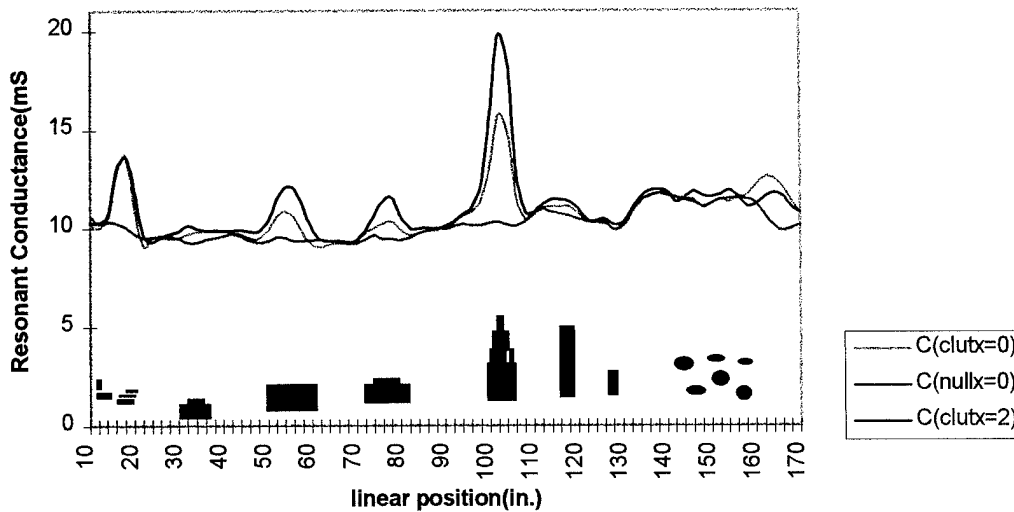
### 3.5 CLUTTER TEST DATA



**Figure 20** Plan view of the absolute value of the difference in measured and average value.

The resonant conductance was measured along the survey lines over the buried objects shown in Figures 1 and 13.

## Resonant Conductance vs position for Clutter Test

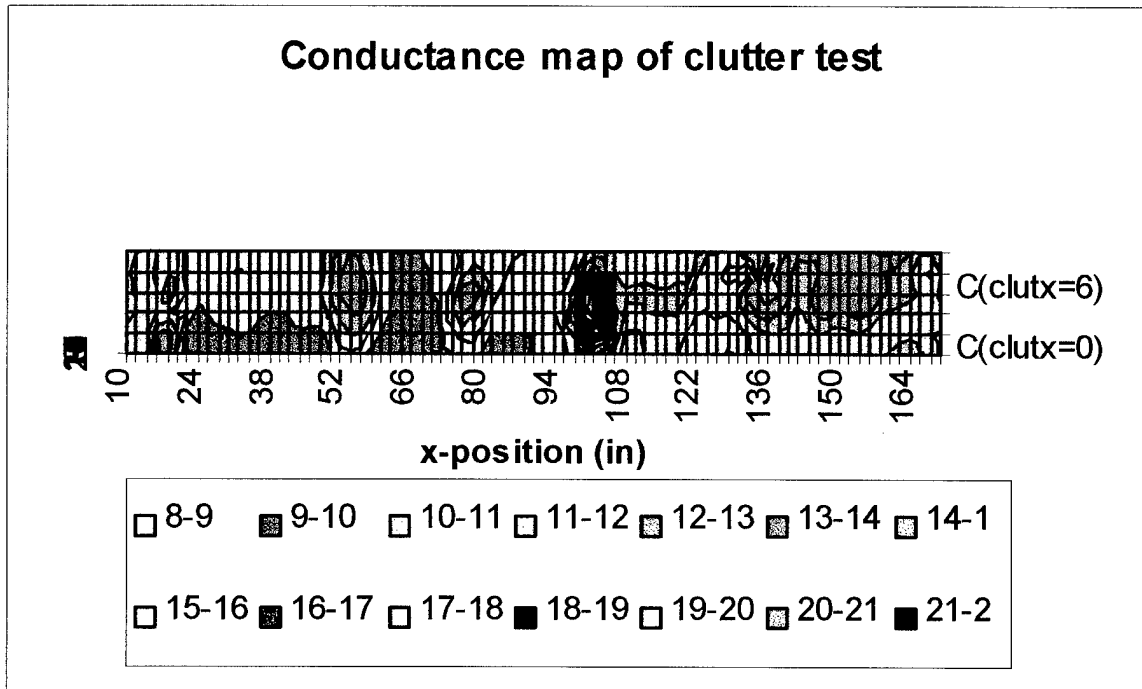


**Figure 21** Measured conductance along the X = 0 and X = 2 survey lines.

The RMPA sensor feed-point conductance was measured prior to burial of the clutter objects and land mines (null X = 0 curve). The buried clutter and land mine data measured along the same survey line is illustrated on the CLUT X = 0 curve. The clutter data measured along the two-inch off set survey line is illustrated on curve CLUT x = 2.

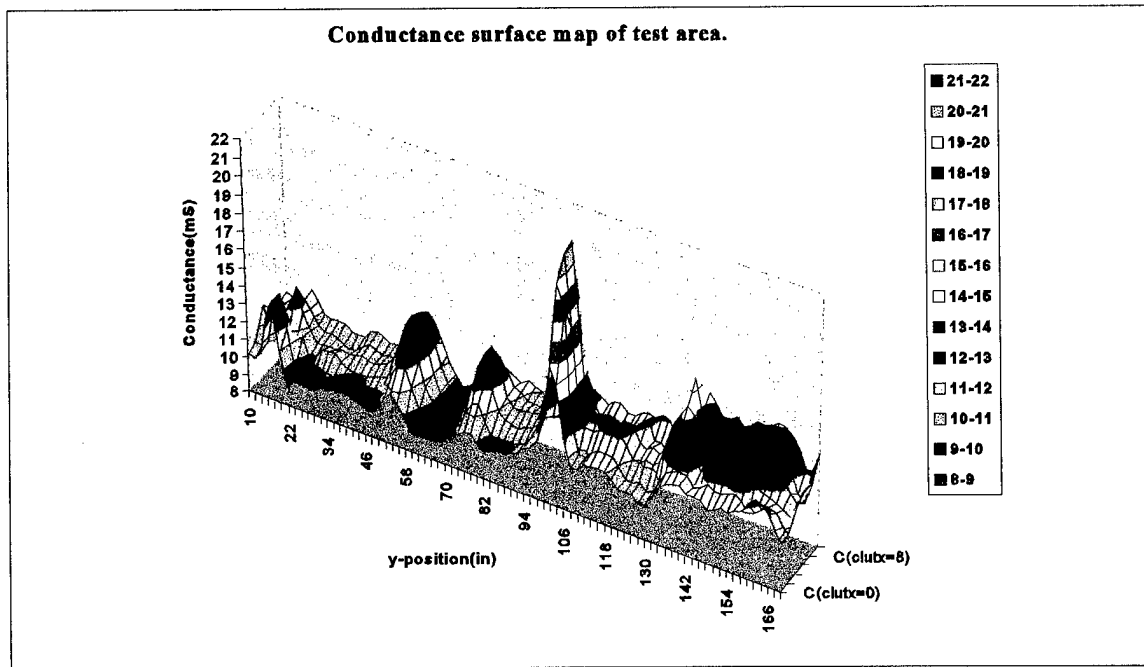
The 3 x 4 inch metal plate at the X = 10 location produced a significant response. The air filled maple syrup bottle, at the X = 96 inch location, produced the greatest false positive response. The nonmetallic antipersonnel mine at the X = 24 inch location produced a very small response because it was buried at a depth of ½ inch. The RMPA stand-off height was approximately 3.5 inches: the minimum RMPA response stand-off. The dielectric cylinder and the antivehicular land mine produced significant responses. The dielectric pipe, shell casing, and river rock produced small responses.

The plan view, rotational view, side view, and oblique views of the measured data show silhouettes of the buried objects.



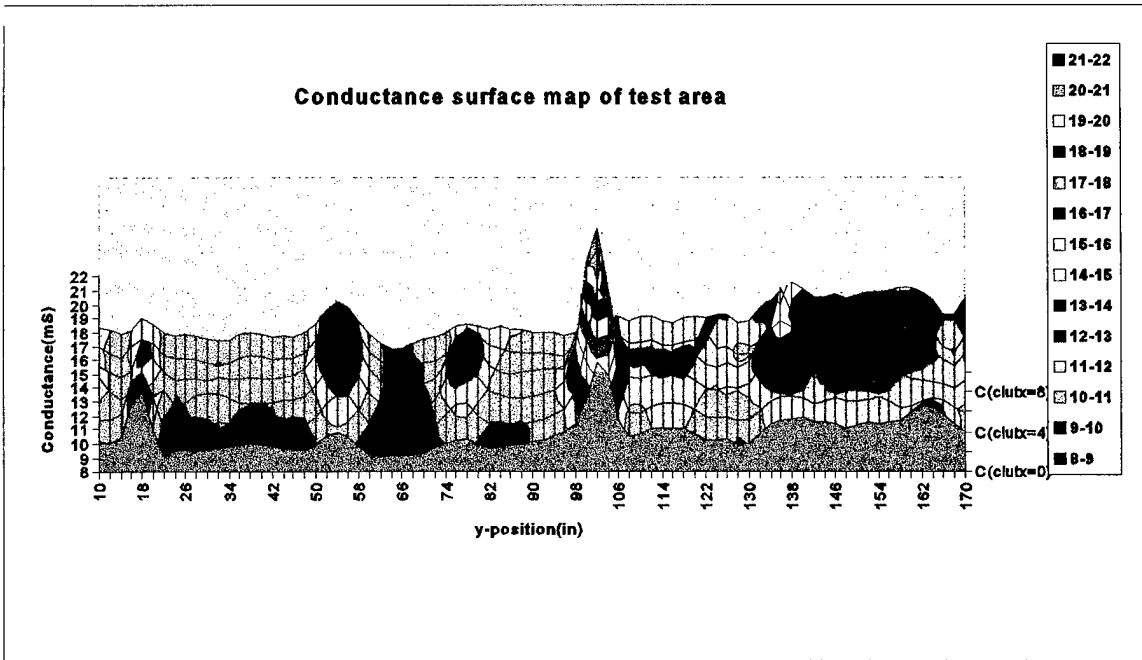
**Figure 22** Plan view of conductance values measured over survey area.

The plan view illustrates the silhouettes of the buried objects. The bottle appears to have an oblong silhouette that is different from a land mine. The dielectric cylinder and the antivehicular land mine exhibit round silhouettes and appear to be land mines.



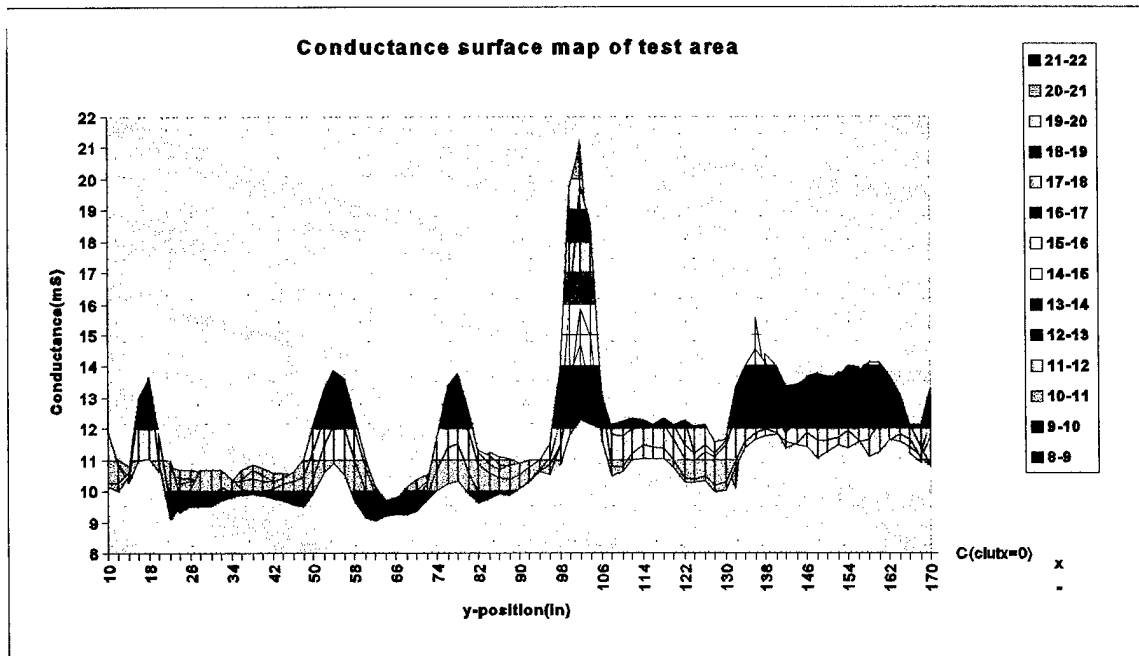
**Figure 23** Rotational and oblique view of conductance values measured over the survey area.

The glass bottle stands out in the oblique view. The metal plate appears to be a wide object. The dielectric cylinder and the antivehicular mine are apparent in the image. The river rocks produce a response; however, the stand-off height merges to within an inch of the soil surface. The stand-off height is approximately 3.5 inches from 10 to 34 inches. This accounts for the low antipersonnel mine detection sensitivity.



**Figure 24** Rotational view of conductance values measured over the survey area.

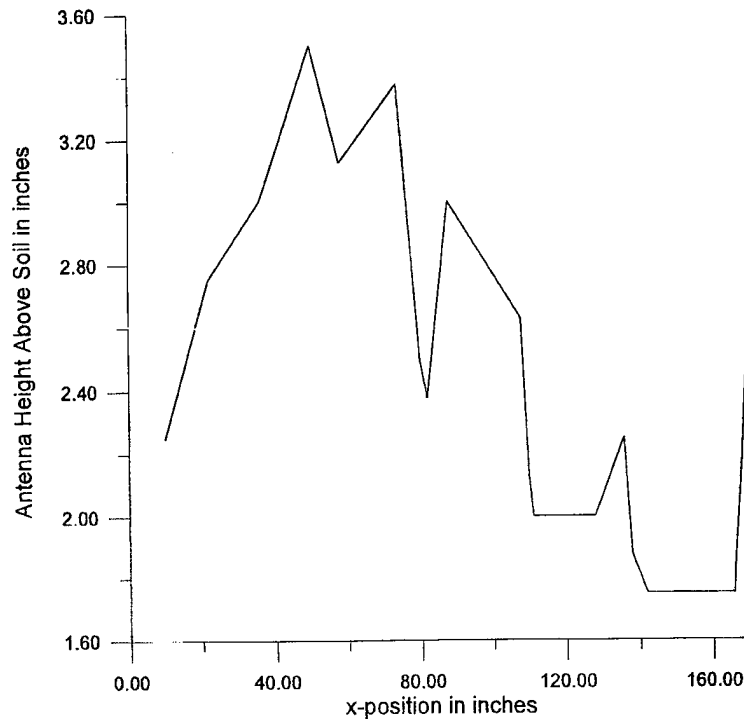
This particular presentation of the data seems to be the best from an object identification point of view. The antivehicular mine clearly stands out in the image.



**Figure 25** Side view of conductance values measured over the survey area.

The contour lines form a silhouette image of the empty bottle. The bottle appears to be six inches long and features a silhouette that is oblong. The images clearly show the dielectric cylinder and the antivehicular land mine. The metal plate does not exhibit a silhouette similar to a land mine. The AP mine is not apparent in the image. This is due to the fact that the sensor stand-off height is approximately 3.5 inches. The detection sensitivity is minimum at this stand-off height.

The RMPA stand-off height was not controlled during this clutter test. The stand-off height was measured at the end of the test and the data is presented in Figure 26.

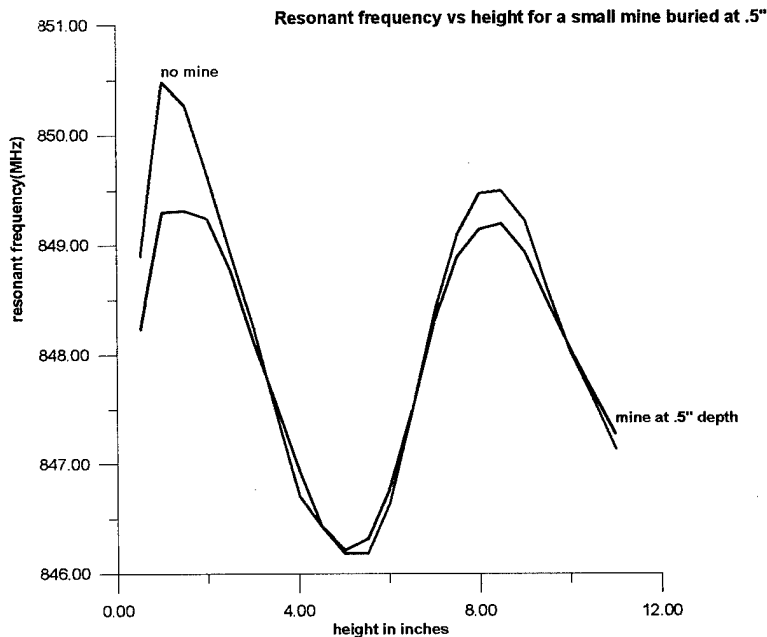


**Figure 26** Measured antenna height above the soil for the clutter test. (Note: This implies a general trend only because these data were taken at various antenna offset positions and over the course of all clutter tests.)

### **3.6 MEASUREMENT OF RESONANT CONDUCTANCE OF THE RMPA SENSOR WHEN SWEEPED OVER ANTIPERSONNEL MINE**

The shallowly buried antipersonnel land mine detection problem was investigated by making a series of resonant conductance measurements.

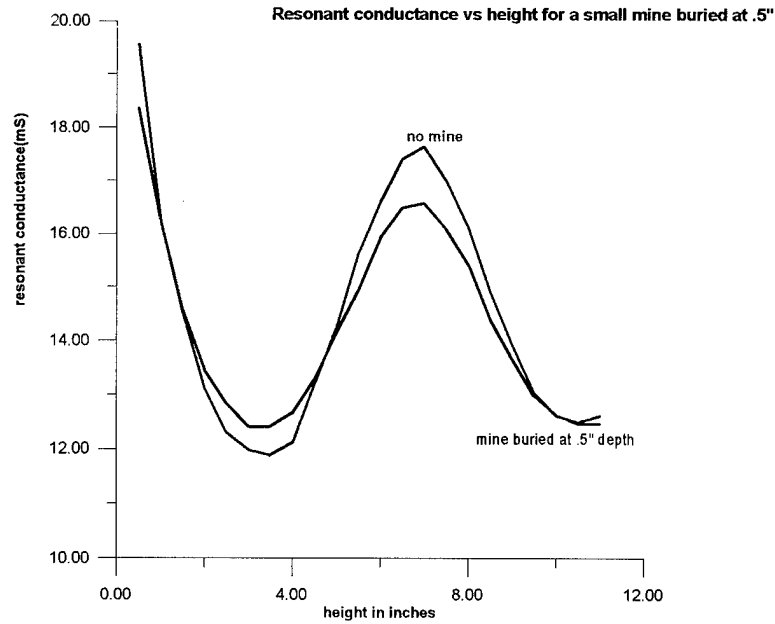
In the first tests, the RMPA response was measured at different heights above the soil surface.



**Figure 27** Frequency change versus RMPA sensor height above soil surface for undisturbed soil and the antipersonnel mine buried at ½ inch.

The resonant frequency appears to decrease when the AP mine is present. The Maximum decrease (sensitivity) occurs when RMPA is near the earth's surface and periodically at the ½ wavelength (6.8 inch) period. The near field resonant conductance is illustrated in Figure 28.

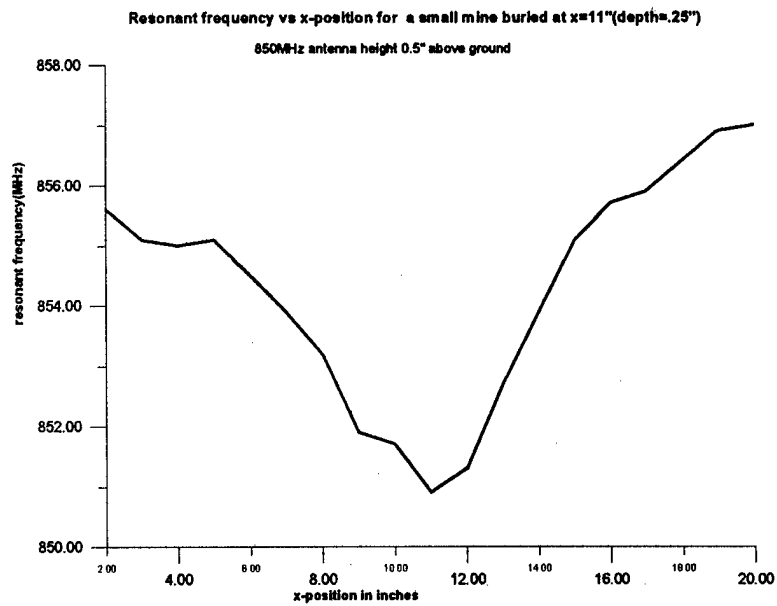




**Figure 28** Measured resonant conductance versus RMPA height above the earth.

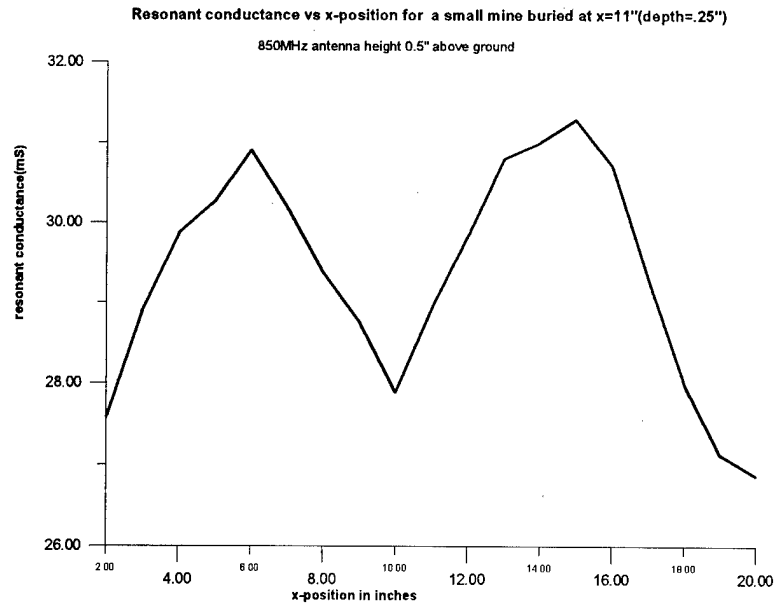
When RMPA is very near the soil surface, the measured resonant conductance decreases from the undisturbed soil condition. The same measurement phenomenon occurs when the RMPA sensor height is increased by  $\frac{1}{2}$  wavelength. The change in resonant conductance is 6.2% at 850 MHz.

In the next test, RMPA was swept over a shallow buried (0.25 inch) AP land mine and the resonant conductance was measured at 1 inch intervals. The measured data is shown for operating frequency of 850 MHz in Figures 29 and 30.



**Figure 29** Measured resonant frequency versus X position swept over antipersonnel land mine at 850 MHz.

The conductance values reach maximum values on each side of the AP land mine. The maximums are located approximately 1.96 cm (5 inches) from the center of the AP land mine.

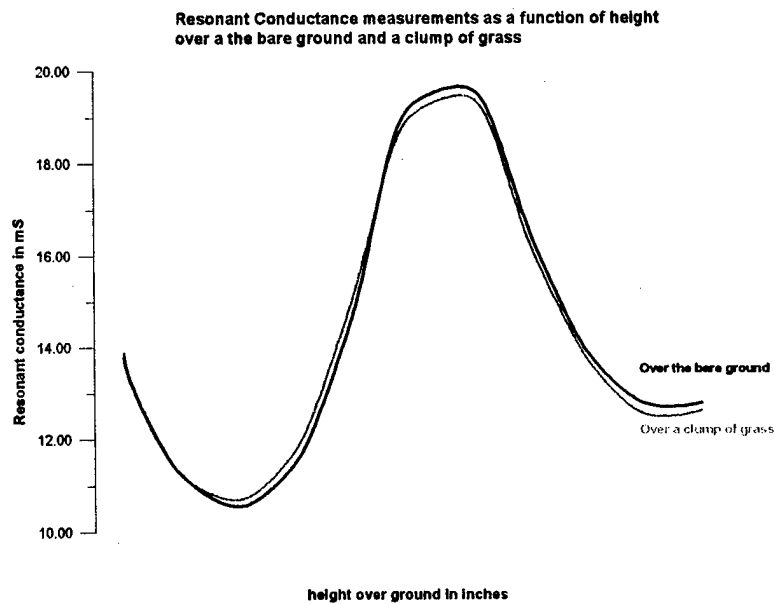


**Figure 30** Measured resonant conductance versus X position swept over an antipersonnel mine at 850 MHz.

The double peaks are observable in the graphical display of the data acquired when sweeping the RMPA sensor over AP land mines buried at various depths. The reason for the double peaks follows from the illustration of the  $TM_{11}$  mode fields shown in Figure 9. When the RMPA sensor approaches the edge of the land mine the circular patch sensor fringing fields are closer to the land mine. This causes a significant change in the RMPA internal cavity fields along with a change in RMPA response.

### 3.7 CLUMP OF GRASS

The sensitivity of the RMPA to a clump of grass was determined by comparing the measured conductance values over undisturbed spoil and a clump of grama grass at the same location. The measured data is illustrated in Figure 31.

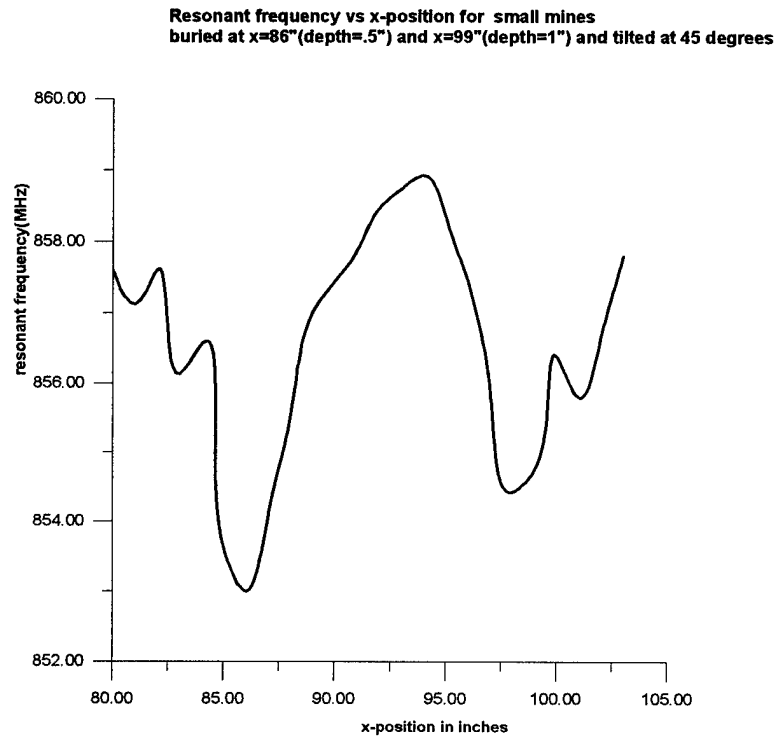


**Figure 31** Measured resonant conductance versus RMPA height over undisturbed soil and a clump of grass.

Since the curves are substantially the same, grass appears to have minimal impact on RMPA measurements. The minimum sensitivity to grass may be due to the fact that the RMPA E-fields are orthogonal to the vertical grass. The E-Field is minimally coupled to the grass.

### 3.8 AP LAND MINE TILTED AT 45 DEGREES

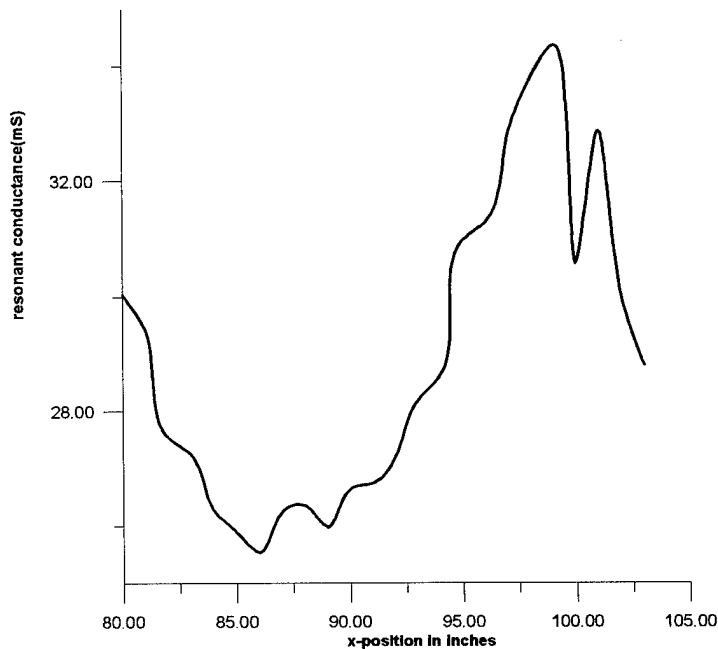
The test was designed to determine the RMPA sensor detection sensitivity for land mines buried with a 45° tilt. The measured data is illustrated in Figure 32.



**Figure 32** Measured resonant frequency in MHz versus X position sweep distance in inches.

The AP land mine is buried at a depth of 0.5 inches at X = 86 inch position. The second land mine is buried at a depth of one inch at the X = 99 inch position. This data shows that the resonant frequency changes by 5 to 6 MHz (approximately 0.6%) when RMPA is swept over the AP land mines. The measured conductance values are illustrated in Figure 33.

Resonant conductance vs x-position for small mines buried at x=86"(depth=.5") and x=99"(depth=1") and tilted at 45 degrees



**Figure 33** Measured resonant conductance in milisiemens versus X position swept distance in inches.

As the RMPA sensor is swept from left to right over these AP land mines, the conductance values reach a minimum value over the AP land mine at depth 0.5 inch and reaches a maximum value over the AP land mine buried at a depth of 1 inch.

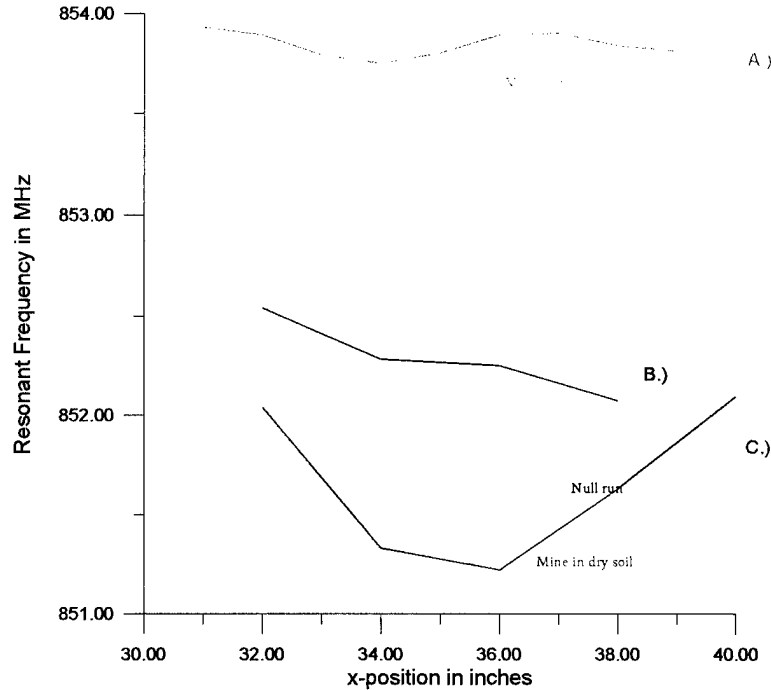
The measured data for the 45° tilted AP land mine exhibits a change in conductivity of approximately 6 mS (22%). This is a change in conductivity of 38 percent.

### 3.9 RIVER ROCK

The photograph of the buried river rock is shown in Figure 3. The conductance presentation shown in the three-dimensional plot is shown in Figure 4. It is impossible to detect the river rock. This is partly due to the large response from the antivehicular land mine. In Figure 17, the test series 2 clutter tests show that the Measured conductivity increases over the river rock in this test. The RMPA sensor stand-off height was nearer to the soil interface which partially accounts for the increase in conductivity.

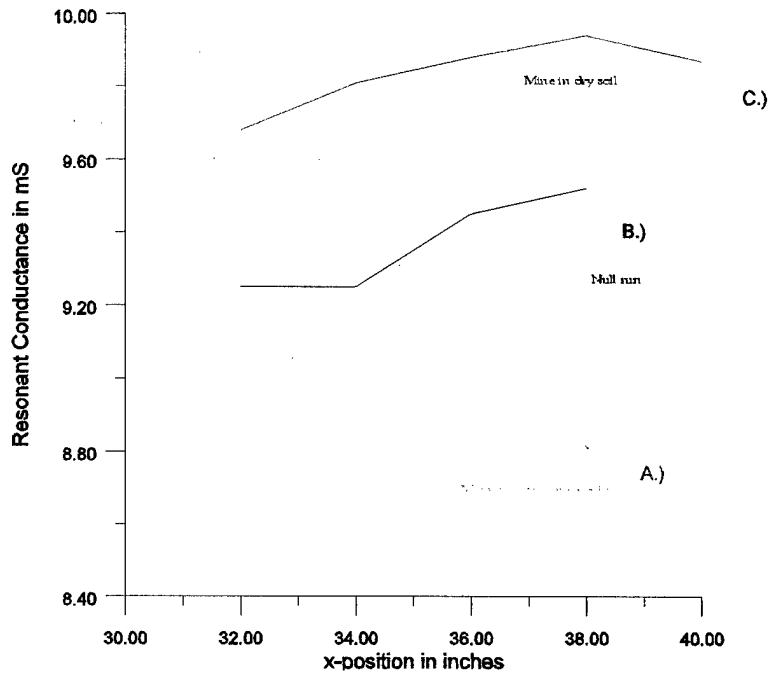
### 3.10 MEASUREMENT OF SOIL WATER SATURATION EFFECTS ON MEASURED CONDUCTIVITY

The RMPA sensor was swept over undisturbed soil and the conductance was measured along the survey line. The RMPA sensor stand-off height was 3.5 inches, near the quarter-wave minimum sensitivity stand-off height. Measurements were repeated for two conditions of soil moisture: normal and saturated. The data is shown in Figure 34.



**Figure 34** Measured RMPA frequency values in MHz versus distance along survey line.

- a) undisturbed soil
- b) normal soil
- c) saturated soil



**Figure 35** Measured RMPA conductance values in milisiemens versus distance along survey line.

- a) undisturbed soil
- b) normal soil
- c) saturated soil.



### 3.11 ANTIPERSONNEL LAND MINE RESPONSE AT 1700 MHZ

The antipersonnel mine was buried at various depths in a grass lawn. The conductance was measured along survey lines directly over the antipersonnel land mine. The measured data is shown in the table below:

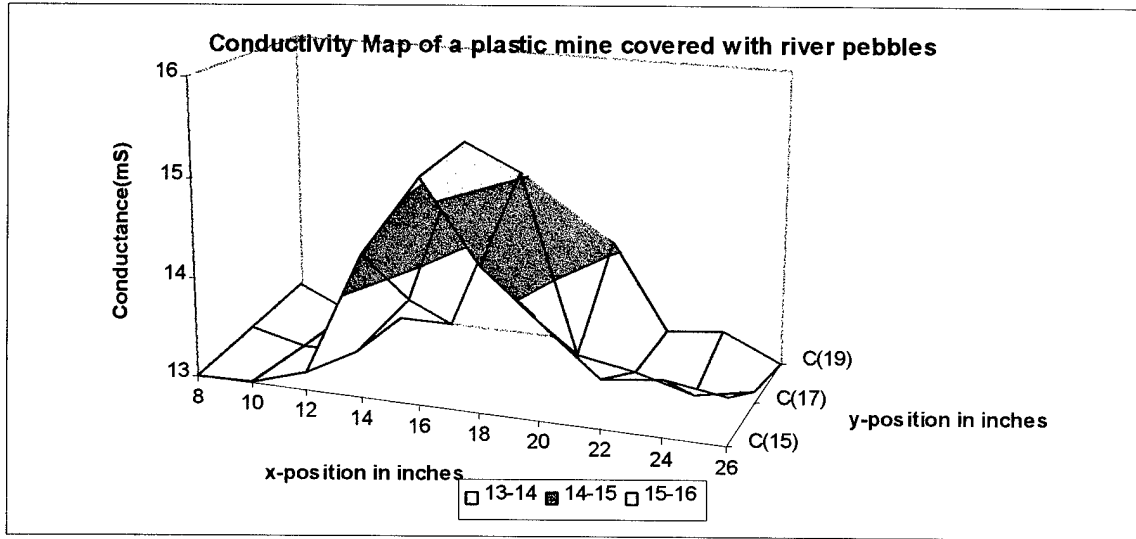
#### MEASURED DATA AT 1700 MHZ Resistance values in Ohms

Distance in inches	no mine	Burial depth in inches			magnetite
		1	1.5	3	
4	25.8	24.8	26	28.5	32
7	26.4	20.6	20.4	21.5	21.5
9 (land mine)	26.5	18	15	18	19.2
11	22.5	24	19	27	21
14	19.5	22	24.9	26.9	27.4

When the soil covering the land mine was removed (buried at a depth of three inches) and replaced with magnetite, the measured conductance values were similar to the 5 inch burial depth values (see far right column of data). This difference in values is within experimental error. The measured data acquired over buried antipersonnel land mines shows that the 1700 MHz RMPA sensor conductance begins to decrease approximately two inches from the antipersonnel mine. The decrease is approximately 6 - milisiemens. This represents a 30 percent change.

### 3.12 MEASURED RMPA RESPONSE OVER RIVER ROCK

An antipersonnel land mine was buried at a depth of two inches. The survey area was covered with one inch diameter river rocks. The measured data is illustrated in Figure 36.



**Figure 36** Measured RMPA conductances with antipersonnel land mine survey area covered with one inch diameter river rocks.

## V CONCLUSION

### 5.1 SUMMARY AND RECOMMENDATIONS

We found that the RMPA sensor and associated microcomputer-controlled electronics can detect and form images of nonmetallic (and metallic) antipersonnel land mines and clutter objects. The RMPA sensor achieves maximum sensitivity when near the air-soil interface and at half wave intervals in stand-off distance. The RMPA sensor design will find application for close-in man carried mine detection.

We found that clumps of grass, roots of oak brush, 2 x 4 inch boards, 16 gauge electric wire, spent shell casings, and river rocks produced very small changes in resonance when RMPA was swept over the clutter test site.

Clutter objects such as 3/4 inch metal pipe, aluminum beverage cans, glass bottles and dielectric cylinders produced significant response. When the unprocessed measured conductance data was presented in two dimensional gray scale or color plots, silhouettes of the clutter objects were formed. Three-dimensional plots of the raw data indicated that metal objects caused local minimums while nonmetallic objects produced local maximums for a given antenna height. This feature may possibly be used as a signature in the identification problem. Since the local minimum or maximum response depends on the scattered wave from the buried object, the min/max response is expected to switch with changes in frequency. This suggests that a multi frequency system would improve both the P.D. and F.P.R. figure of merit.

When the measured data were processed by subtracting the average value and taking its absolute value, the min-max response was converted to a local maximum (peak) response over the buried objects. Three-dimensional graphical representations seem to be more idealistic and effective in the identification problem. With this type of imaging, we were able to determine that the 3/4 inch pipe, aluminum can, and glass bottles were not land mines.

Nonmetallic antipersonnel land mines were detected and the "absolute" value imaging presentation assisted in the identification of these mines. When the antipersonnel land mine was buried within one half inch of the surface, the RMPA sensor swept response exhibited a local maximum values on approach and departure from the antipersonnel mine. Directly over the antipersonnel mine, a local minimum appears in the data. To experimentally evaluate the phenomenon, the test frequency was changed from 850 to 1700 MHz. At 1700 MHz, only a minimum was found over the antipersonnel land mine. This experimental finding added to our conviction that a multi frequency system will improve identification of buried objects.

Other related tests found that when water was used to saturate the soil overlying

the antipersonnel land mine, the detection sensitivity improved. This is due to the increased dielectric constant contrast between the saturated soil and the antipersonnel mine. Regional changes in soil moisture are expected to produce false positive responses. This is a common problem in scattered wave imaging. Imaging is an important factor in resolving this problem. Fusing the RMPA sensor with an IR sensor could resolve this problem. Magnetite in the overlying soil did not significantly change the RMPA sensor response to buried antipersonnel land mines. The orientation of the land mine did not significantly affect the resonance because of the scattering phenomenon. Electrical noise from power lines, internal combustion engines, and hand held radios had no effect on the response.

Changes in stand-off height caused by footprints, tire tracks, and local erosion will, have an impact on the measured conductance values. If a stand-off height sensor (acoustical sensor) were fused with this sensor, the effectiveness of RMPA would improve.

The RMPA sensor operates with high detection sensitivity at 850 MHz. A multi frequency design is recommended to overcome the strong detection sensitivity dependance on stand-off height and burial depth. The multi frequency system appears to enhance the identification and image forming aspects of the RMPA system. An image forming capability is required in the identification of land mines and clutter objects.

<b>Clutter Object</b>	<b>Clutter Response/Comments</b>
Roots	no effect
Grass	no effect
Rocks	small perturbation
Single rock covering mine	Mine detected with and without rock
Many small rocks covering mine	Small effect; improved detection with disturbed soil
8 rifle shell casings	Small but definite signal; enhanced in wet soil
chopped, disturbed soil	Minimal influence but
Magnetite covering mine	Mine still seen
Dr. Pepper can	Large response; imaged
Maple syrup bottle	Large response; imaged; less contrast when filled with water
Lucite cylinder (mine size)	Detected like a mine
coins	Same response as shell casings
Metal pipe ( $\approx$ 3 cm diameter)	Definite response and image; enhanced ion wet soil
dielectric pipe	Nearly invisible
wood block	Small perturbation
metal strips/plates	Large response
cow pie	No effect
metal plate under mine	Slightly enhanced and broadened signal
metal plate over mine	Reversed the conductance change
metal plate over mine but on the surface	Increased the response; probably sensing more of the metal

**APPENDIX A**

**MATHEMATICAL MODEL  
OF  
ENERGY DENSITY**

**SOIL DIELECTRIC CONSTANT OF 4  
REFLECTION COEFFICIENT OF 0.33  
PHASE REVERSAL AT SOIL-AIR INTERFACE OF 180°**

**APPENDIX B**

**TEST SEQUENCE NULL MEASURED DATA  
RMPA HEIGHT ABOVE SOIL SURFACE NOT CONTROLLED**



# **Analysis and Time Frequency Processing of Scattered Signals from Submerged Mines in Shallow Water**

**Lawrence Carin and Marc McClure**  
Duke University, Dept. of Electrical Engineering,

In this paper we describe the underlying phenomenology characteristic of acoustic scattering from an elastic mine submerged in shallow water. The scattered pressure from such a target is characterized by wavefronts scattered from localized scattering centers (e.g., the surface of the mine first encountered by the incident wave), followed by sustained oscillations at complex frequencies characteristic of target resonances. Additionally, the shallow water channel acts as an acoustic waveguide, characterized by multiple waveguide modes and significant dispersion. In the time domain, the waveguide dispersion is manifested as a chirp, with the arrival time of particular frequency components dictated by their respective group velocities. The impact of the dispersive water channel is an important issue to be considered in underwater mine detection and identification (largely ignored heretofore). We have developed a signal processing algorithm that exploits the aforementioned underlying phenomenology. The scheme, referred to as wave-based matched pursuits, projects the pressure scattered from a submerged mine onto a basis composed of wavefronts, resonances and chirps. This scheme is used for target detection and identification. Results are presented from data measured by the Naval Research Laboratory, as well as for mine acoustic scattering data computed numerically via rigorous numerical algorithms.

---

Because a full paper was not received by publication date, the above Abstract appears in this Proceedings. The lead author can be reached at P.O. Box 90291, Durham, NC 27708-0291.





# **Imaging Small Scatterers in Shallow Water from Towed Array Data**

**Meng Xu and Norman Bleistein,**  
Center for Wave Phenomena,  
Colorado School of Mines

This paper describes a computer code developed for the imaging of small objects in shallow water from data gathered on the surface with a towed array. The underlying theory has been successfully used to invert data for seismic exploration. The survey is traditional. A boat carries a towed array along parallel lines on the upper surface and periodically sets off an acoustic sources, collecting the resulting backscattered data on the array. These data are re-sorted in common (constant) offset data sets and processed to produce a reflector map based on the theory developed by Bleistein. In addition, the output provides an estimate of the specular reflection coefficient at the sample points on the scatterer, as well as an estimate of that incident specular angle with respect to the normal to the reflector. By processing the data for a suite of offsets, data for amplitude versus offset (AVO) or amplitude versus angle (AVA) analysis is generated for each point on the reflector. This provides a basis for medium characterization of the scatterer. The formalism effectively back propagates the data in a background medium. For this code, that medium is assumed to be depth-dependent. To calculate the amplitude weights for a 3-D common offset  $v(z)$  inversion program, analytic formulas for computing 3-D ray data in a depth dependent propagation medium are used. These ray data are interpolated from ray coordinates to cartesian coordinates after ray tracing. It is the efficient computation of these data that is the main challenge of the program development. From these ray data, all of the necessary constituents of the inversion formula are computed and the image processing proceeds. The numerical tests confirm that the computer code matches analytical values of the travel time and amplitude along the rays extremely well. Furthermore, for a model sphere in a constant background, we find that the reflector map successfully produces an image of the sphere. We also present output from processing seismic survey data.

---

Because a full paper was not received by publication date, the above Abstract appears in this Proceedings. The authors can be reached at the Center for Wave Phenomena, Colorado School of Mines, Golden, CO 80401-1887; telephone, 303-273-3461; e-mail, <norm@dix.mines.edu>.



# **Development of a Conductively-Cooled Superconducting Magnet System for Mine Countermeasures**

**Dr. E. Michael Golda  
Naval Surface Warfare Center**

The Advanced Lightweight Influence Sweep System (ALISS) is a United States Navy Advanced Technology Demonstration (ATD) designed to validate the feasibility of using superconducting technology to conduct mine countermeasures. A superconducting coil produces a magnetic field to sweep magnetic influence mines. Superconducting technology was initially investigated for this mission in the early 1970s, but the impact of helium logistics requirements and system weight prevented deployment in the fleet. Since that time, advances in refrigeration technology have permitted the use of mechanical cryocoolers to conductively cool a magnet system to superconducting temperatures (approximately 4 K), eliminating the liquid helium logistics burden and significantly reducing system weight. The ALISS ATD demands higher performance under significantly more severe conditions than any commercial superconducting magnet application. The ALISS superconducting magnet must be rugged, have a high dipole moment, have a short charge time, and have the lowest possible weight. The first phase of the ALISS ATD was a joint Navy/industry effort to improve the performance of superconductors, cryocoolers, compressors, magnet supports and thermo-mechanical interfaces to meet Navy performance requirements. In addition, two of the largest conductively cooled magnet systems in the world were successfully manufactured and tested to validate design performance and evaluate the performance of component interfaces. Based on the success in meeting the exit criteria of the first phase, the second phase commenced with a contract for the design and manufacture of an at-sea demonstrator which was awarded in June 1995 to General Atomics of San Diego. The design was completed in April 1996. The final phase of the program will be the participation of the system in Demonstration II of the Joint Countermine Advance Concept Technology Demonstration (ACTD) in FY 1998.

---

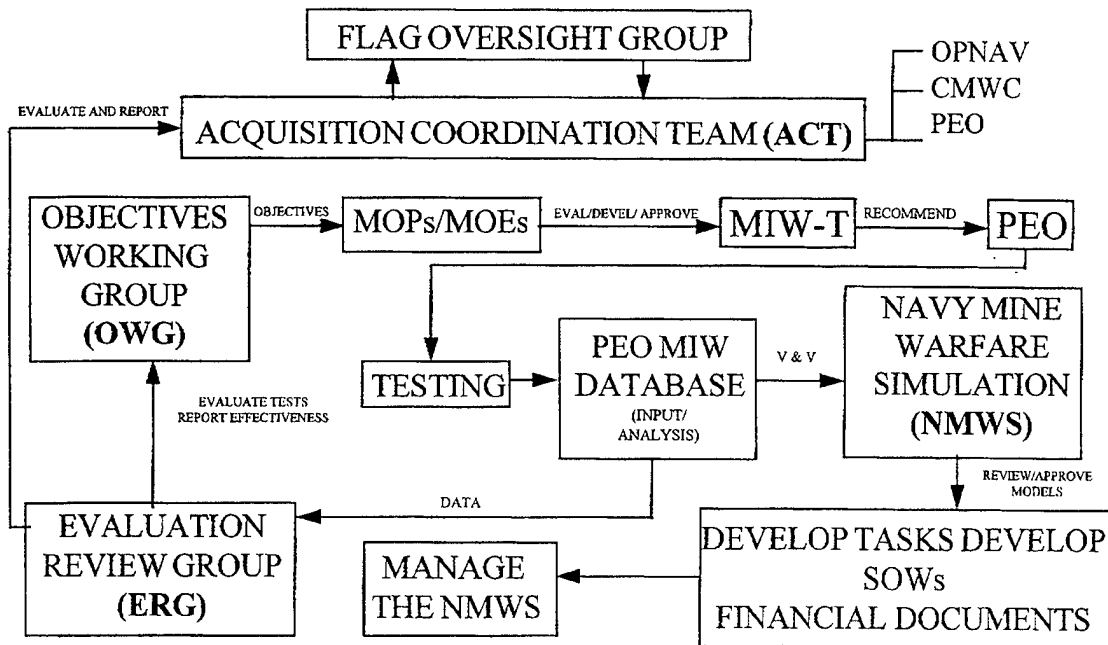
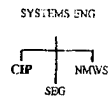
Because a full paper was not received by publication date, the above Abstract appears in this Proceedings. The author can be reached at the Naval Surface Warfare Center, Code 812, Annapolis, MD 21402-5067; telephone, 410-293-3359; e-mail, <golda@aosys.dt.navy.mil>.



# The Continuous Improvement Process (CIP)

RADM Richard D. Williams III, USN  
 PEO Mine Warfare,  
 Chair for the Session on Navy Mine Countermeasures

## CONTINUOUS IMPROVEMENT PROCESS (CIP)





# **CHAPTER 8: ALTERNATIVE APPROACHES TO MINE CLEARANCE, TECHNOLOGIES FOR OBSTACLES AND THE SURF ZONE**

## **EXPLOSIVE CLEARANCE OF MINES AND OBSTACLES**

During World War II, beach defenses were "softened up" through the process of laying a carpet of explosives by rocket from specially outfitted ships. Also, in that same conflict, the British introduced the Bangalore Torpedo -- an explosive hose pushed ahead of advancing armor and infantry to clear away mines. The principle remains the same today, with improved versions of explosive nets, saturation bombing, and even extremely large explosive charges (in the range of 15,000 pounds of explosive) designed to be placed with precision so that they can be detonated in a closely controlled time sequence all having a place in the amphibious assault "toolkit." The name PELEC (Precision Emplaced Large Explosive Charges) is given to this latter approach. The claim is that explosives detonated in this manner will create a channel free of mines and obstacles.

It should be noted that, although they are prepared to use them for such missions, the U.S. Air Force is not enthusiastic about diverting its Heavy Bombardment assets (B-52s) to this type of action.

In a defensive minefield, one can expect to find both mines and obstacles. The mines protect the obstacles, and the obstacles protect the mines. This is, in effect, a man-made enhancement of well-known effects of the physical environment.

Session XX of the Symposium was on the subject of breaching of mine and mine/obstacle fields by explosive means in the surf zone and craft landing zone. The purpose of such clearing is to allow for a large-scale assault from the sea. It is deemed necessary to quickly -- i.e., on the order of two hours -- bring in assets from beyond the horizon to clear 50-yard channels of all mines and obstacles in these zones for the landing forces.

There were several papers, both theoretical (most on scaling laws) and experimental, which treated the effectiveness of several explosive approaches (line charges, explosive nets and bombs) in clearing mines and obstacles from the surf zone and craft landing zone. New concepts were presented on pulse power technology, using arrays to focus pressure waves towards specific regions to clear the lanes. One paper described a system under development by the Russians which uses a multiple rocket barge to carpet an area. Finally, a small hand-held system for clearing a narrow walking lane for a foot soldier was described.

We are indebted to Mr. Lee Hunt, former Executive Director of the Naval Studies Board of the National Academy of Sciences, for bringing together the contributors to this Session, and for the papers that are included in this Chapter.



## **FARMING, ROAD-BUILDING AND PIPE-LAYING EQUIPMENT IN COUNTERMINE / OBSTACLE APPLICATIONS**

It seems natural to look to the civilian sector of the economy for approaches to working in all kinds of terrain. Agricultural machinery must be robust and mobile. So must heavy road-building and pipe-laying equipment. Just look at the environments in which loggers must work.

Since the First Symposium on Technology and the Mine Problem in April 1995, there has been considerable interest in using commercial off-the-shelf (COTS) equipment for mine countermeasures/countermine applications. The U.S. Marine Corps has tested the CLAUSEN Power Blade in tough beach and hard pan environments for its ability to breach both minefields and heavy obstacles. And the U.S. Army is testing various devices for utility in Humanitarian Demining as well as military countermine operations. This Chapter contains contributed papers that deal with the use of such heavy-duty engineering machinery. Mr. Bill Baker of Clausen Power Blade, Inc. acted as Session chair and presented the vendor/entrepreneur viewpoint. His paper appears in this Chapter.

# **“COORDINATION OF DEPARTMENT OF DEFENSE EFFORTS FOR THE DISPOSAL OF UNEXPLODED ORDNANCE”**

Christopher O'Donnell  
Naval Explosive Ordnance Disposal Technology Division  
Indian Head MD, 20640

## **SUMMARY**

There is increased interest in the Department of Defense (DoD) in clearing unexploded explosive ordnance (UXO). In response to a congressional request, DoD has established a UXO Executive Committee that is preparing a report detailing the efforts in the areas of detection and disposal of UXO. This paper describes the actions taken by DoD to prepare this report and offers the opportunity for those currently outside the DoD UXO community to take part in this effort.

## **INTRODUCTION**

The DoD is currently facing safety hazards associated with UXO in many diverse mission areas. UXO is explosive ordnance prepared for action, which has been fired or placed in such a manner as to constitute a hazard to operations, installations, personnel or material and remains unexploded either by malfunction or design or for any other cause. Since the DoD is the sole customer and user of explosive ordnance in this country, DoD has recognized that it is the single proponent for research and development of tools and techniques to deal with UXO. In order to provide the most benefits from these research and development efforts in a time of diminishing resources, a coordinated approach to the problems of detecting and disposing of UXO is needed. Five distinct DoD communities are involved in UXO related research; Combat Countermine, Explosive Ordnance Disposal (EOD), humanitarian demining, active range UXO clearance and UXO site remediation. Each of these communities has varying needs and applications for UXO clearance. The coordination of these communities will allow the DoD UXO community to clearly define future of DoD UXO research.

In September of 1995 the General Accounting Office published a report calling for a coordinated approach to research and development for UXO needs. This recommendation was forwarded to the DoD by House National Security Committee in the report on National Defense Authorization Act for FY96. An Office of the Secretary of Defense directive in June of 1996 called for the establishment of a UXO Executive Committee. A UXO Clearance Charter was then established. The charter calls for a DoD UXO Executive Committee to be formed, with members from OSD, the Services, and the Joint Staff. This includes Director, Strategic and Tactical Systems; the Service Acquisition Executives (SAEs); representation from Force Structure, Resources, and Assessment Directorate of the Joint Staff; Deputy Under Secretary of Defense, Environmental Security; Director, Test Systems Engineering and Evaluation; Assistant Secretary of Defense(Special Operations/Low Intensity Conflict); Director of Defense Research and Engineering and others.

The executive committee is chaired by the Under Secretary of Defense (Acquisition & Technology), or his designee. The committee provides policy guidance to the steering group as

needed and during semi-annual program reviews. The executive committee ensures that the overall UXO effort is well-structured, and will approve the jointly-developed program plan. The plan will be updated periodically, as needed. The executive committee is responsible for resolving any unresolved issues between the participants. The executive committee also liaisons with other Government agencies involved in UXO clearance by extending invitations at the working-level to attend subgroup meetings, and by working with established inter-agency working groups.

Assisting the DoD Executive Committee is a UXO clearance Steering Group (07/SES), responsible for communications on UXO-related research, development, and acquisition matters. This steering group resolves issues that cannot be resolved at the subgroup level, and will elevate issues that cannot be resolved to the executive committee. The steering group will have an alternating Army and Navy chair, with a vice-chair from the other service.

The membership of the steering group includes members from the Army, Navy, the Marine Corps and the Air Force, the Joint Staff, designees of the executive committee members from the OSD staff, and others. Additionally, the chairs of the two technology subgroups and the chair of the requirements coordinating subgroup participate in the steering group. Issues that cannot be resolved in the steering group will be referred to the executive committee.

The steering group annually reviews and approves an integrated plan for unexploded ordnance clearance that describes RDT&E priorities, program management, and cooperative activities with international programs. This plan is being developed from the inputs of a UXO clearance requirements coordinating subgroup and two UXO clearance technology subgroups.

It is the responsibility of the three subgroups to review RDT&E activities across mission areas to ensure that there are no gaps in the program, and that there is no unnecessary duplication of effort. In the case of duplication, the subgroups will recommend, to the steering group, a technically sound course of action to either eliminate or justify the duplication. In cases where there is overlap between the responsibilities of the technology subgroups, it will be the responsibility of the Steering Group to ensure that these activities are appropriately coordinated.

The three groups interact to prepare the DoD UXO Clearance Plan. The subgroups have the following responsibilities:

*1. Requirements Coordinating Subgroup (Fort Leonard Wood Engineering School/Joint Services EOD Deputy Manager for Technology cochairs)*

This subgroup provides input to the UXO clearance plan from the UXO user communities as to current requirements and anticipated program initiatives in each specific area. The requirements coordinating subgroup will be composed of a user representative for each of the technological mission areas: (a) combat countermine activities, (b) humanitarian demining, (c) UXO site remediation, (d) active range UXO clearance, and (e) EOD. Other agency representatives from outside DoD may also be invited to join the requirements subgroup, as needed, and will serve in an advisory capacity.

The requirements subgroup works with each technology subgroup to ensure that selected technological approaches provide an effective solution, as well as to increase leveraging of

technological approaches that present a potential solution for specific needs. This subgroup does not develop new requirements. Each of the communities involved has their own process for validating and funding equipment requirements. This group focuses on harmonizing the requirements of the communities to increase the probability of leveraging ongoing and planned research and development efforts.

It is the responsibility of the technology subgroups to demonstrate that R&D activities responding to mission area requirements are fully coordinated, and that leveraging of similar technology efforts is occurring. There are two technology subgroups, separated broadly by function as follows:

2. *Detection/Location/Classification/Interrogation Technology Subgroup (Army chair).*  
This group coordinates RDT&E activities that pertain to sensor development (detection as well as classification and interrogation), data processing and management including advanced algorithm development and sensor fusion, sensor platforms including autonomous vehicles and robotic systems, navigation, and registration techniques.
3. *Removal/Render Safe/Neutralization/Disposal Technology Subgroup (Navy chair).*  
This group coordinates activities that pertain to technologies for excavation (including autonomous vehicles and robotic systems), disposal, breaching, improved render safe capabilities, data and information management, risk management, protection of personnel and resources, and explosives hazard mitigation

As a minimum, there are technical representatives in each technology subgroup from organizations responsible for the RDT&E in the following mission areas: (a) Combat Countermining Activity; (b) Humanitarian Demining; (c) UXO Site Remediation; (d) Active Range UXO clearance; and (e) Explosive Ordnance Disposal.

Figure (1) provides a overview of this organization.

## **DISCUSSION**

The basis for the coordinated plan is a UXO Database. In this database both requirements and technology for UXO clearance are captured. Each record in the database contains a requirement section that calls out the type of need, detection or disposal, and what functional area these needs address. The functional areas of concern to the DoD UXO Community are:

### **Detection**

- Detection
- Locate-Mapping
- Locate-Marking
- Identify/Evaluate/Exploit

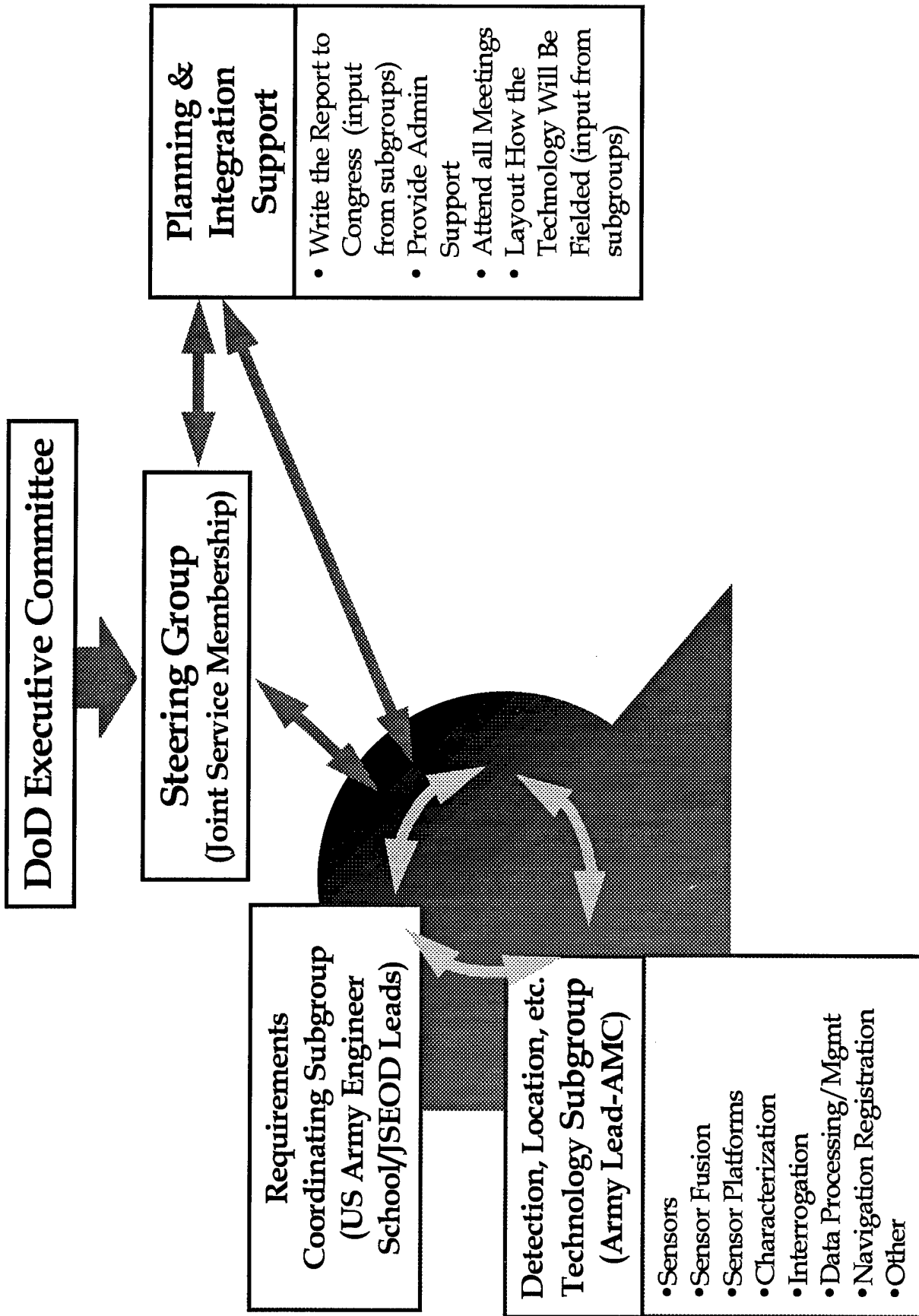


Figure 1

## Disposal

Breaching  
 Access  
 Neutralize/Render Safe  
 Recover  
 Disposal  
 Training

In the disposal area these functions are a combination of the functions performed by each mission area. Table 1 provides an overview of these functions.

	Pre-mission	Access	Identification	Neutralization	Recovery	Disposal	Ordnance Design
Combat Countermine	1. Decision Tools	1. Bobby Traps 2. Antitampering 3. Hand digging 4. Vegetation 5. Terrain	1. Mine like	1. Disarm 2. Destroy 3. Move 4. Function 5. Proof	1. Remove	1. OB/OD	1. Self Destruct/ Neutralize 2. Command Detonate
Humanitarian Demining	1. Training 2. Decision Tools	1. Bobby Traps 2. Antitampering 3. Hand digging 4. Vegetation 5. Terrain	1. Mine like 2. Type	1. Destroy 2. Move 3. Function 4. Proof			1. EOD Feature 2. Protected Fuzing
Explosive Ordnance Disposal	1. Training	1. Bobby Traps 2. Antitampering 3. Hand digging 4. Vegetation 5. Terrain 6. Excavation	1. UXO like 2. Type 3. Model	1. Render Safe 2. Disarm 3. Destroy 4. Move 5. Function 6. Proof	1. Remove 2. Pull Out 3. PUCA 4. Transit 5. Store	1. OB/OD 2. Environmental Compliance	1. EOD Feature 2. Protected Fuzing
Active Range UXO Clearance	1. Training 2. Decision Tool	1. Antitampering 2. Hand digging 3. Vegetation 4. Terrain 5. Excavation 6. Environmental Impact	1. UXO like 2. Type 3. Model	1. Render Safe 2. Destroy 3. Move 4. Function	1. Remove 2. Pull Out 3. Transit 4. Store	1. OB/OD 2. Environmental Compliance 3. Ordnance Scrap 4. Certify Scrap 5. Disposal of Scrap	1. EOD Feature 2. Protected Fuzing 3. Green Explosive 4. Self Destruct/ Neutralize 5. Command Detonate
UXO Site Remediation	1. Training 2. Decision Tool	1. Antitampering 2. Hand digging 3. Vegetation 4. Terrain 5. Excavation 6. Environmental Impact	1. UXO like 2. Type 3. Model	1. Render Safe 2. Destroy 3. Move 4. Function	1. Remove 2. Pull Out 3. Transit 4. Store	1. OB/OD 2. Environmental Compliance 3. Ordnance Scrap 4. Certify Scrap 5. Disposal of Scrap	1. EOD Feature 2. Protected Fuzing 3. Green Explosive 4. Self Destruct/ Neutralize 5. Command Detonate

Table 1

A review of these functions show both the similarity and diversity of these functions. While many areas are similar and can benefit from harmonization of requirements and review of like technologies, many other functions are unique to the mission areas.

The disposal sub-group reviewed these functional areas and the output of the requirements sub-group. The functional areas were further defined by establishing technology thrust areas. These areas allow the grouping of like technologies and identify their application to UXO Disposal needs. The nine major thrusts are:

Personnel Protection - Eye protection, foot to groin protection, improved ballistic body armor. Includes interaction modeling, damage assessment testing, material development, blast mitigation techniques, shields, berms and barriers.

Vehicle Protection - Mine blast survivable, sniper/artillery survivable, protect from UXO blast and fragment hazards. Includes interaction modeling, damage assessment testing, material development, blast mitigation techniques and armor.

Excavation - Remote and autonomous excavation of buried UXO. Includes remote control, autonomous control, navigation, force feedback control, precision manipulation and effector sensing.

Booby Trap Access - Defeat antidisturbance features including trip wire, breakwire and electronics. Includes grappling hooks, "silly string", lasers, signature reduction, electronic jamming and explosively driven tools.

Remote Vehicles - unmanned ground vehicles for reconnaissance and manipulation of UXO. Technologies include remote control, autonomous control, precise manipulation, navigation, communication and perception.

Area Clearance - methods for rapidly clearing large areas of landmines and UXO. Includes distributed explosives, directed energy, armored vehicles with plows/rakes/flail/rollers, remote vehicles for moving surface munitions, large bombs, subsurface clearance vehicles and chemical/biological remediation.

Small Charges - alternatives to standard military explosives that reduce weight, cost and can not be used to create improvised explosive devices. Includes explosive formation/effects modeling, explosive formulation, warhead design, fuze design, effects testing and thermal effects.

Breaching - Rapid breaching of mine fields and surface UXO. Includes distributed explosives, armored vehicles with plows/rakes/flail/rollers and large bombs.

Environmentally Compliant Disposal - methods for disposing of UXO and UXO components that reduce impact to the environment. Includes open burn/open detonation (OB/OD), blowing an item in place (BIP), chemical reaction, thermal reaction, water jet cleaning, and the use of large recycling shredders.

The current capabilities and technology development programs associated with UXO disposal are widely spread across the 9 thrust areas. Capabilities as simple as a can of "silly string" for the detection of trip wires are listed along with technology development programs for high power laser diodes for neutralization of UXO are listed in table (2). The table lists the thrust area, which of the five UXO Mission Areas is supported, and provides a preliminary analysis of current and future capability.

Current UXO clearance missions require that the operator access a explosive hazard area that is defined by the landmine and UXO upon which they will operate and those landmines and UXO that surround the targeted item. A current deficiency exists in the weight, bulkiness and high temperature environment that accompanies the use of mine apparel or bomb suits. The army is currently developing materials and suit designs that can benefit both the deminer and the UXO clearance operator. Similar technologies are currently being applied to HUMMMVs and other military and commercial vehicles to increase the survivability of passengers. Work continues in this area to raise the upper limit of survivability when actuating a landmine or large UXO item. EOD Technicians operating in Bosnia have found that current EOD tools do not allow for disruption of booby traps in confined areas. Smaller explosively driven tools are under development to address this need. The ability to dig buried UXO lies primarily with manually operated backhoes with some examples of single remote systems. The use of remote systems has proved successful in operation in Bosnia and in EOD applications. Systems under development for the last few years are now completing engineering development and are ready to field.

Once any access concerns have been dealt with, the neutralization of the landmine or UXO needs to be accomplished. This can be done by rapid breaching, single operators against one target or by standoff methods using directed energy or robots. Rapid breaching of landmines is the focus of the Anti-Personnel Obstacle Breaching System (APOBS) and the Explosive Standoff Mine Breaching (ESMB) system. The Navy is also investing in Distributed Explosive Technology and the Marines are developing the Joint Amphibious Mine Countermeasures (JAMC) system. Single operator techniques for neutralization focus on the use of bulk explosives or specialized EOD tools. There is currently no tools fielded for use against large numbers of targets such as found in mine fields or UXO areas. Current systems for clearance of large areas rely on operator interaction with the target or actuation of a landmine fuzing mechanism. Techniques such as Blow-in-Place (BIP) or Pick-Up-and-Carry-Away (PUCA) have been used to rapidly clear areas of landmines or UXO. These techniques have led to the death of both military and contractor personnel in clearance operations CONUS and OCONUS. These operations are normally carried out by rapidly trained individuals under the supervision of an EOD Technician. Accidents occur due to the complacency and boredom associated with picking hundreds of items. BIP carries additional concerns in developing nations because the standard military explosive used can be acquired and used to fabricate improvised explosive devices. Combat engineer forces have a large number of mechanical and electronic devices at their disposal to function the fuzing in a landmine and cause detonation. The mechanical items (flails, plows, rollers, etc) cause pressure or tilt rod fuzes to actuate. Electronic devices such as VEMASID project a magnetic signature that causes magnetic mines to actuate. The Army is also developing ORSMIC to cause initiation of other fuzing mechanisms. These effectiveness of these systems is degraded when used to clear UXO because of different fuze actuation environments.



REQUIREMENT	MISSION AREA					Assessment	Current Systems	Current Tech	On-going Programs
	CM	FOD	DEMINE	UXO-AC	UXO-REM				
Personnel Protection	X	X	X	X	X	red	bomb suits, mine apparel, lexan booth, lexan ATV shield, mortuary shield, man portable shield, general (sand bags, berms, barriers, etc.)	ballistic materials, blast/flare resistant materials, water absorption	mine apparel, commercial bomb suits, computer man
Vehicle Protection	X	X	X	X	X	amber	HUMMV protection, Armored APC, rapid runway repair vehicle	ballistic materials, blast deflection, sacrificial components	blast hardened excavator, 5 Ton truck protection, SUV protection, protective tires
Booby Trap Access	X	X	X			amber	hand tools	hand tools, wire cutting laser	sensor defeat tools, active spoofing
Excavation		X	X	X	X	amber	backhoes (manual/remote), rig and dig	commercial construction equipment with special remote packages, shovels	remote CEE, precision excavating, autonomous excavator, air knife
Breaching	X					amber	plows, rollers, explosive line charges, flails, VEMASID	move item, mechanical actuation of fuzing, mechanical destruction, magnetic signature duplication	ESMB, APOBS, DET, SABRE, JAMC, ORSMIC, magic carpet, thunder road
Remote Vehicles	X	X	X	X	X	amber	RECORD, RCT, ROMES, miniflail, panther, HERC, STS, M48/M60 targets	duplication remote control	RONs, BUGS, JAMC, ORSMIC, TODS, RRR
Smaller Charges	X	X	X	X	X	amber	EOD energetic tools, RF initiation, demo charges	shaped charges, slug throwers, thermal treatment, bulk explosive	ESMB, chemical neutralization, jet perforators, LIDD, MCD, HVSC, RF detonators, thermite
Area Clearance	X	X	X	X	X	red-amber	BIP, PUCA, SMUD, line charges, flails, plows, rollers, VEMASID	trained operators, small arms fire, bulk explosives, mechanical detonation/destruction	ESMB, MODS, HLONS, BUGS, ORACLE, SSCV, SCV, SC matrices, IDX, FAE, large bombs, MAGPIE, berm processor, Spitfire, HPM, JAMC, Clausen blade
Environmentally Compliant Disposal		X				red	OB/OD, BIP, Demil	open burn, detonate, permitted demil facility	Chemical Demil, shredder, transportable kiln, transportable chemical demil, scrap recovery

Table 2

In certain environments, the disposal of landmines and UXO by open burn/open detonation (OB/OD) methods is unacceptable. No systems currently exist for the treatment of UXO in field environments. UXO will need to be packaged in accordance with DOT regulations and shipped to a hazardous waste disposal facility. This will create a safety hazard to the general public due to moving UXO in an unknown state off of military land.

Currently the Disposal sub-group is working with the requirements and detection sub-group to establish a defensible evaluation criteria that identifies currently capability and the potential for technologies to increase that capability. Factors that must be taken into account for current capability are: safety, resources needed to perform mission, effect on pace of operations, cost and defined user needs. For technology the following factors must be addressed: state of technology, promise of technology, time to field and development cost.

## **CONCLUSIONS**

With the current interest in the clearance of UXO from so many diverse communities and the pressures of a reduced budget a coordinated approach to DoD UXO research and development is critical. By using a requirements driven approach we can ensure that the scant resources applied to this area provides maximum benefits to the users communities. The use of a requirements driven approach that is has sponsorship by more than one of the user communities will also assist in ensuring these technologies are defended through the acquisition process.

The harmonization and clarification of requirements benefits the entire academic, contractor and DoD development community. An electronic database of requirements will allow scientists, engineers and technicians to match their promising idea to a user need. This will reduce false starts and allow contractors to focus their own research on real user needs.

Coordination of technology resources will allow a wider and deeper program for UXO. By identifying existing programs and ensuring maximum leveraging of information, the resources in these mission areas can be applied in a more efficient manner. Instead of all five communities working on similar robotics systems, one community effort can be identified as lead. This would allow the other communities to focus their resources on another need in their area.

In order for any of this to occur the UXO database must be completed. Information from existing, past and planned efforts must be input and correlated to existing requirements. Ideas from contractors and academia must be input and evaluated. Finally the database must be provided to the DoD, United States and International communities associated with detecting and disposing of UXO or any other buried item.

## **Recommendations**

In order to see this process through, DoD must institutionalize the database for use by all interested parties. Feedback from users and developers will be critical to ensuring DoD provides the resources to continue this effort. Finally, more input is needed from inside/outside the DoD community. In order to provide our soldiers, sailors, airmen and marines with the finest products with the limited resources available, all potential solutions must be reviewed.



# **SURF ZONE TECHNOLOGY**

## ***ENABLING OPERATIONAL MANEUVER FROM THE SEA***

**Daniel A. Crute  
Naval Surface Warfare Center  
Coastal Systems Station  
Panama City, Florida**

### ***INTRODUCTION***

*The central naval problem is now one of crossing hostile littorals  
and imposing the military power of the U.S. onto the land.*

*-- High Seas, ADM William A. Owens*

### ***Power Projection from the Sea***

The global changes in this decade, along with our experience in Operation Desert Storm, have led to a fundamental reshaping of our national military strategy. Naval doctrine is changing to reflect this reshaping and to define a new role for the Navy in the military strategy of the future. ...*From the Sea and Forward...From the Sea* began to articulate the new Navy role. These documents emphasize power projection from the sea as part of a new focus on expeditionary warfare.

The thrust toward expeditionary warfare has led to a new emphasis on littoral warfare, with a recognition of a need to rapidly cross the littoral region with a power projection capability. The Marine Corps concept of *Operational Maneuver from the Sea (OMFTS)* provides the means for accomplishing this rapid movement from sea to shore. The concept emphasizes swift maneuver from over the horizon, through the surf zone and beach, to objectives ashore. An amphibious assault will no longer be a slow, deliberate operation with high attrition and a massive build up of combat power on the beach. The fluid, dynamic operational maneuver will move swiftly through the littoral region and on to inland objectives.

### ***The Challenge of Mines and Obstacles***

The proliferation of mines in today's world presents a formidable challenge to the successful accomplishment of the OMFTS concept. Mines provide a cheap, lethal threat that even the less developed nations can utilize to defend their shores against such a power projection attempt. Mines, possibly combined with man-made obstacles, can substantially restrict the mobility of our forces during an operational maneuver.

A clandestine reconnaissance capability will enable our forces, in some cases, to exploit gaps in the defenses, going around the mine fields rather than through them. However, some warfighting situations will require a capability to breach the mine fields and obstacles, in order to best achieve the military objectives. Then, we need a rapid, flexible, long standoff breaching capability to catch the enemy by surprise with a swift maneuver through rapidly breached mine fields.

## ***TECHNICAL CHALLENGES***

*Power projection requires mobility, flexibility, and technology  
to mass strength against weakness.  
-- ...From the Sea*

### ***The Threat***

The surf zone includes the region from ten feet of water depth to the high water mark. Threat mines in that region can range from small anti-personnel and anti-tank mines to much larger shallow water bottom mines. Mechanisms to initiate the mines include pressure plates, tilt rods, chemical horns, and magnetic influence fuzes. Mines are often densely concentrated, and may be combined with obstacle defenses. Obstacles may range from heavy concrete barriers to much lighter steel obstacles, such as concertina wire. The possibility of direct and indirect fire from the shore intensifies the lethality of the combined threat.

### ***The Environment***

The wave action, currents, and rapid change in the surf zone make it a difficult operating environment. The turbidity, bubble content, and acoustic noise in the water combine to make a very difficult sensing environment. Many of the techniques for reconnaissance and clearance in deeper water or on land do not work effectively in the surf zone.

### ***The Challenge***

The difficulty of the threat and the environment, along with the operational constraints of OMFTS, lead to significant technical challenges. We need to develop technologies for effective sensing in the surf zone environment. We need technologies to enable rapid, remote, accurate delivery of clearance systems from over the horizon. And we need ways to constantly improve the effectiveness of our clearance systems, utilizing computational methods to optimize clearance capability.

## ***INVESTIGATIVE APPROACH***

*We will experiment with the latest technologies, concepts, and methods  
to enhance the operational effectiveness of our forces.*

*-- GEN Charles C. Krulak, CMC*

The Surf Zone Technology program, sponsored by the Office of Naval Research, utilizes a dual focus approach to address the technical challenges. One focus area concentrates on developing our knowledge base of physical interactions in the surf zone. This involves testing and analysis to better understand the vulnerability of mines and obstacles and to develop explosive effectiveness models. These "knowledge base" efforts divide into two main thrusts: Mine Neutralization and Obstacle Breaching.

The other focus area concentrates on developing innovative technologies to enable a "next generation" warfighting capability. The emphasis is on developing the rapid, flexible, long standoff reconnaissance and clearance capability that will enable operational maneuver from the sea. The focus on advanced concepts includes a concept assessment process and several areas of new technology development.

## ***KNOWLEDGE BASE***

*One major catalyst of change is the advancement of technology.*

*-- Warfighting (USMC)*

### ***Mine Neutralization***

When the Surf Zone Technology program began, in 1992, the main focus was on developing computational analysis capabilities and test data bases to predict and optimize the performance of explosive neutralization systems against surf zone mines. This emphasis has continued as one of the thrusts of the program. The Mine Neutralization investigations support current system development programs, such as the Assault Breaching System (ABS), and technology demonstrations, such as the Explosive Neutralization Advance Technology Demonstration (EN-ATD). The Mine Neutralization thrust includes three projects: Sand and Mine Response Models, Explosive Performance Models, and Mine Vulnerability.

The Sand and Mine Response Models project is developing a computational capability to predict the propagation of explosive shock through the complex surf zone environment, which includes sand, water, and entrained air, with multiple material interfaces. The computational capability is being developed by adapting increasingly sophisticated material models to hydro-codes and coupled hydrodynamic / structural analysis codes. Controlled laboratory testing and field testing provide test data for validation of the computational methods.

The Explosive Performance Models project is developing quick analysis tools for the optimization of explosive line charges and distributed explosive arrays. These models, based on hydro-code results, take only minutes to run on a PC, while the hydro-code models require hours on a mainframe computer. The models predict pressure, impulse, and energy at points in the sandy bottom, resulting from explosive shock. The first version was released in 1996.

The Mine Vulnerability project performs tests and analyses to determine the vulnerability of foreign threat mines to explosive shock. Threat mines vary widely in construction and initiation mechanisms. Each mine type is examined for internal mechanical details. Finite element models are developed to predict vulnerabilities. Explosive tests are performed to determine actual response to shock. Vulnerability studies have been performed for pressure plate anti-tank mines, tilt rod anti-tank mines, and tilt rod anti-invasion mines.

### ***Obstacle Breaching***

Rapid, remote clearance of man-made obstacles, especially when combined with mine fields, poses a difficult problem. Current tactics involve SEAL teams with satchel charges in a very difficult and dangerous mission. If obstacles are surrounded by mines, SEALs cannot go in until the mines have been neutralized.

Many of the concepts under consideration for obstacle breaching utilize explosive charges or directed energy warheads. To better understand the effectiveness of these concepts, two projects are investigating the vulnerability of obstacles: Obstacle Vulnerability and Bomb Effects.

The Obstacle Vulnerability project includes testing and computational analysis to investigate the vulnerability of heavy concrete obstacles to various types of directed energy warheads. Warheads tested have included shaped charges, explosively formed penetrators (EFPs), kinetic energy penetrators, and others. These were tested against unreinforced concrete targets, primarily four foot cubes. The damage rules resulting from tests and analysis will provide a tool for optimizing warheads against concrete targets.

The Bomb Effects project is investigating the effects of existing bombs against a variety of obstacle types. Computational analysis and testing will determine the effects of single detonations, sequential detonations, and simultaneous detonations, both in air and in water (surf zone depths). The resulting damage models will enable us to evaluate and optimize various concepts for using guided bombs to breach obstacle bands.

## **ADVANCED CONCEPTS**

*We will emphasize high leverage, leading edge technology enhancements  
to increase our capabilities.*

*-- Joint Vision 2010*

The rapid advance of technology makes possible tomorrow what can only be imagined today. Throughout the history of warfare, and especially modern warfare, the nation that has utilized the best available technology has gained a distinct advantage. The accelerating pace of technological advancement in the world today demands that we constantly look into the future and determine how emerging technologies can enhance, or revolutionize, our warfighting capabilities for tomorrow.

The Advanced Concepts focus area of the Surf Zone Technology program is identifying and developing concepts that apply emerging technologies to provide a "next generation" capability for reconnaissance and clearance in the surf and beach zones. The aim is to fully enable the operational concepts envisioned for the future by the Navy and Marine Corps, such as OMFTS. To accomplish that, a Concept Assessment project was initiated in FY 1996, which has led to two new projects focused on Long Standoff Delivery and Surf Zone Reconnaissance.

### ***Concept Assessment***

*Focusing initially on certain high payoff opportunities  
will create a leap in our amphibious power projection capability.*

*-- MCM in Littoral Power Projection (USMC)*

The Concept Assessment project was initiated to provide a systematic process for evaluating the numerous advanced concepts proposed for surf zone reconnaissance and clearance. The process includes investigations into technical feasibility and operational utility, to enable wise decisions for investment in technology development. Beginning with a broad search, the process gradually narrows the focus to technologies with the highest payoff potential.

The Advanced Concepts Steering Committee (ACSC) serves as the recommending body for the Concept Assessment process. Members come from a wide range of organizations, including representatives from the fleet, the requirements and acquisition communities, and the science and technology communities. The ACSC meets once a year to review the latest proposals and investigations, making recommendations for the initiation of concept studies, warfare analyses, and further technology development and demonstration. The Committee met for the first time in June 1996, and recommended investigations into long standoff delivery of guided bombs for obstacle clearance and the use of small autonomous vehicles for surf zone reconnaissance.



## ***Long Standoff Delivery***

*Long range precision capability, combined with a wide range of delivery systems, is emerging as a key factor in future warfare.*

*-- Joint Vision 2010*

Rapid improvements in precision delivery and autonomous guidance and control are converging to enable new possibilities for delivery of clearance systems from over the horizon. Several GPS-guided glider delivery concepts have been investigated in the Surf Zone Technology program. Warfare analysis indicates that a combination of several clearance systems with guided glider delivery could clear two breaching lanes on typical beaches in approximately thirty minutes, providing a tremendous step forward toward a rapid, flexible, long standoff capability.

The Long Standoff Delivery project is investigating technologies for delivering guided bombs from over the horizon to breach bands of obstacles. This mission will require highly accurate placement with near vertical orientation of the bomb at impact to optimize the effects of fragmentation of the bomb case. Yet, the delivery package must remain relatively low-cost to allow for the numbers required for a breaching mission. An analysis of options, supplemented by modeling and simulation, will determine the key technologies to pursue for enabling long standoff delivery for obstacle breaching.

## ***Surf Zone Reconnaissance***

*The ability to take advantage of opportunity is a function of speed, flexibility, boldness, and initiative.*

*-- Warfighting (USMC)*

Maneuver warfare involves the rapid exploitation of opportunities, utilizing tempo and surprise, to shatter the enemy's cohesion. A key to seizing opportunity is effective reconnaissance. The force commander who knows the defenses and the actions of his enemy has a distinct advantage.

Studies confirm that a reconnaissance capability in the surf zone, identifying locations of mines and obstacles, would dramatically increase our ability to maneuver safely through gaps or cleared lanes. Airborne and undersea surveillance and reconnaissance capabilities are improving rapidly, but have severe limitations in the surf zone environment. A unique surf zone reconnaissance capability is needed to complement the existing and developing systems for wide range surveillance and reconnaissance.

The Surf Zone Reconnaissance project is investigating technologies to enable a network of small, autonomous, bottom-crawling vehicles to perform reconnaissance operations in the surf zone. The key technical challenges are:

- Sensing in the surf zone environment
- Navigation and location for small vehicles
- Communication from vehicles to the network hub
- Vehicle stability and mobility

This effort builds on recent technology developments in small autonomous vehicles, close proximity sensors, and underwater communications. The concept involves a network of autonomous vehicles searching the surf zone with multiple sensors and reporting back or marking the locations of mines and obstacles. Such a capability will enable the incoming forces to exploit gaps in the defenses or target the existing defenses with precision-guided breaching systems.

### ***VISION FOR THE FUTURE***

*Power projection, enabled by overseas presence, will likely remain  
the fundamental strategic concept of our future forces.  
-- Joint Vision 2010*

As we peer into the mist of the future, many factors combine to increase the uncertainty of our predictions -- unstable politics, volatile nations, and rapidly advancing technology. In the midst of these uncertainties, we must discern the trends in order to anticipate the future as well as possible, enabling us to harness the dynamics of change to our advantage, rather than resisting change and being trampled by it.

In the Surf Zone Technology program, we have made every effort to anticipate the future. We have consulted with fleet staffs, doctrine developers, MCM commanders, scientists, and technologists to gather information on trends for the future. We have been assisted by experienced naval officers in developing operational concepts that describe a generalized power projection operation in approximately the year 2010. These concepts provide an operational framework for the Concept Assessment process, so that advanced system concepts can be evaluated in the context of a future operation. Workshops, Broad Agency Announcements, and brainstorming sessions have provided the ideas for advanced concepts that will apply new technologies to the surf zone.

We have taken care to ensure that our vision of the future supports the broader vision of the Navy and Marine Corps, as expressed in documents such as *Concept of Operations for Mine Countermeasures in the 21st Century* and *A Concept for Mine Countermeasures in Littoral Power Projection*. The technologies currently in development in the Surf Zone Technology program, and elsewhere, have the potential to bring the vision to reality.

## *Continuum of Capability*

To turn vision to reality, we must have a strategy to get from here to there. That strategy must provide a continually improving capability, while moving toward the ultimate goal. The current acquisition programs (6.4), technology demonstration programs (6.3), and exploratory development programs (6.2) lead to a progression of improvements that will provide a continuum of capability, culminating in a rapid, flexible, long standoff capability that will enable swift maneuver from over the horizon.

## *Military Payoff*

The reconnaissance and clearance technologies developing in the Surf Zone Technology program have the potential for tremendous military payoff in critical areas. The surf zone reconnaissance efforts will enable the exploitation of gaps in the enemy's defenses and dramatically increase our ability to clear quickly by identifying the location of mines and obstacles. A long standoff clearance capability will facilitate swift surprise attack, while reducing risk to personnel through the use of remote systems. The knowledge base of explosive performance models and target vulnerability data will provide tools to optimize clearance effectiveness, improving the effectiveness of the military operation and reducing lift requirements. All this contributes to a power projection capability that will overwhelm the enemy with swiftness and effectiveness.

## *Enabling Operational Maneuver*

*We specialize in maneuver warfare from over the horizon,  
using the ocean to project force at soft points in the enemy's defense.  
-- ...From the Sea*

Expeditionary Warfare requires a strong power projection capability that can be rapidly applied anywhere in the world. Operational Maneuver from the Sea pits our strength against the enemy's weakness by catching him off guard with quickness and surprise. Our forces of the future must have speed, agility, and flexibility coupled with reconnaissance and clearance capabilities that will enable them to go around or through any impediment.

The technologies and concepts now in development in the Surf Zone Technology program can provide our forces with the means for moving rapidly across the surf zone and beach, enabling operational maneuver from over the horizon to objectives ashore. Clandestine reconnaissance, long standoff breaching systems, and effective clearance capabilities will give the force commander the ability to exploit or create gaps as the situation requires. With a combination of a knowledge base to optimize effectiveness, advanced concepts to enable swift maneuver, and an assessment process that ties new concepts together into a cohesive operational concept, the Surf Zone Technology program is providing keys to enable our expeditionary forces to project power from sea to land in tomorrow's world.

# THUNDER-ROAD: Ballistically Delivered Distributed Explosive Nets

Donald Robeson, NSWC, Coastal Systems Station  
Michael Farinella, Foster-Miller, Inc  
Arnis Mangolds, Foster-Miller, Inc

## Summary

Thunder-Road is a project for developing the technologies for packaging and deploying distributed explosives from conventional bomb casings. The Thunder-Road concept is adaptable to any distributed net or film system, however, during this program it has been developed for the delivery of detonation cord suitable for defeating surf zone threats. The advantages of such a system for in-stride breaching include: delivery by conventional fixed wing aircraft, immediate flexible response to a minefield's geometry and the ability to hold the minefield clearing munitions in real time reserve. The modular approach is advantageous for stability of the array in the surf zone as compared to larger strip type deployments.

The Thunder-Road design approach considers the physical properties of the net, design of the net to minimize aerodynamic drag, ejection from the bomb casing, fast uniform deployment, and the surf zone hydrodynamics. Tests have shown that a detonation cord net can be packaged and deployed from conventional Mk-65 Quickstrike and the SUU-76 type casings within their ballistic envelopes. Designs indicate that the concept is generally adaptable to any bomb, or missile launched munitions. The result is that conventional Marine, Navy or Air Force close air support aircraft and tactics can be used for the surf zone mine clearance problem. This paper describes the results of the deployment and in-water tests conducted in development of this technology.

## Concept of Operation

The goal of this project is to develop the technologies and techniques that enable bomb delivery of distributed explosive arrays that are

packaged in a space efficient, ordnance certified container. The goal is to provide tested, proven alternatives to the current developmental LCAC mounted rocket deployed delivery system for explosive arrays.

Deployment is achieved by executing a series of timed events that free the payload and then open the net (Figure 1). Fused by a ground proximity sensor an explosively split casing is triggered and discharges the net package free from ancillary hardware. A timed or mechanically tethered fuse simultaneously ignites several small rockets that evenly pulls the net's perimeter in a radial direction. The net and package are designed to minimize the aerodynamic resistance by maintaining a low exposed profile during the opening event. At water impact the rockets gradually shut down to minimize snapback. The net sinks to the bottom and after a predetermined interval of time or on command, detonation occurs.

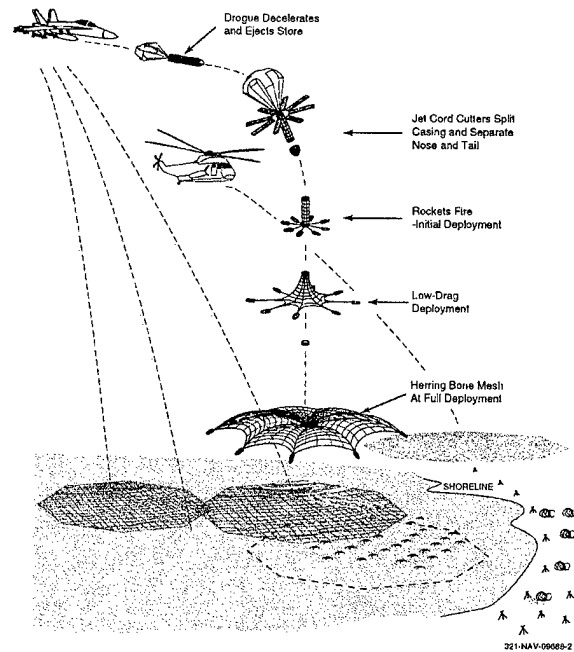


Figure 1. Thunder Road Concept

## Technical Issues

The Thunder Road concept relies on multiple small rockets being able to expand a net at a location close to the ground. The planned approach for this effort has been to focus on identifying the critical design elements, testing full scale net sections, and then testing full scale net arrays. Other critical elements include fusing and deployment sequencing, canister ejection mechanism, and coverage reliability.

Very little information on similar systems exists in the literature with the closest being parachute systems. Unfortunately the Thunder Road array has a porosity value of 95%, and the parachute models are generally only applicable to 12% porosity limits. If a Thunder Road array were designed differently using the 12% porosity level the extra material required would double the necessary volume needed, and increase opening time, from less than a second to tens of seconds, with a resulting decrease in accuracy.

Models have been recently developed by the Explosive Neutralization ATD which model the lateral, down range flight of a similar array when propelled by rocket motors. The outcome of this effort, including drag coefficients and modeling approach, have been used to develop a working model of the Thunder Road system. Initial studies helped define the number of rockets, required burn time, and expected trajectory of the system.

From a technological perspective the following items were identified as being critical to the success of Thunder Road. This paper focuses primarily on the first issue, and touches briefly on the other issues.

- Develop approaches for reliable array extraction, spreading, and maintaining expansion while experiencing dynamic loading associated with dropping the bomb at operational speeds.
- Develop technologies to optimize array packaging and minimize damage.

- Determine placement accuracy of multiple arrays.
- Assess stability of net design to surf zone hydrodynamic environment.

Previous studies of rocket deployed systems have shown that while scaling can be used in the early stages to save costs, the drag, surf stability, and other environmental effects can only be understood at full-scale sizes. Similarly, the mechanism for separating and pushing apart the bomb casing is being performed at full-scale. Preliminary tests are conducted at smaller scales where appropriate. While it could be argued that smaller scale tests would be more cost effective, it was felt that this would leave so many unanswered questions, it would not be useful. In summary, the size of the array that can fit in the bomb casing allows a full-scale deployment and produces a more robust and defensible concept.

## Technical Accomplishments

The following discussions describe the testing performed to analyze the technical issues.

### *Surf stability tests*

An analysis of the effect of wave forces on the drift of the array in the surf zone was conducted and indicated that the array would maintain its shape on the bottom. The full-scale array was next tested in a wave tank (Figure 2) to measure sink rate and stability in surf. Test conditions simulated a high sea state 2 surf condition. The results were encouraging and suggested that the chosen circular design was consistent with the predicted performance and will remain relatively stable in the surf zone.



Figure 2. Surf Zone Stability Tests

### Drop testing

A major portion of the verification testing for assessing the performance of the Thunder Road system at various stages of development has been achieved by drop tests. Testing started with drops from a small tower, followed by drops from large cranes, and most recently testing from commercial helicopters. These tests are summarized in Table 1.

### B-Series Tests

The packaged array for the B-series tests was designed to fit within the volume allowable in a Mk 65 Quick Strike mine casing (21" diameter, 72" tall) as shown in Figure 3. The net design was customized for Thunder Road applications to minimize material volume while maintaining the necessary grid spacing between detonation cord centers. A herringbone pattern for the array was chosen as the best choice to minimize volume, minimize number of splicing required (reduces manufacturing costs and improves reliability), and minimizes fabrication space.

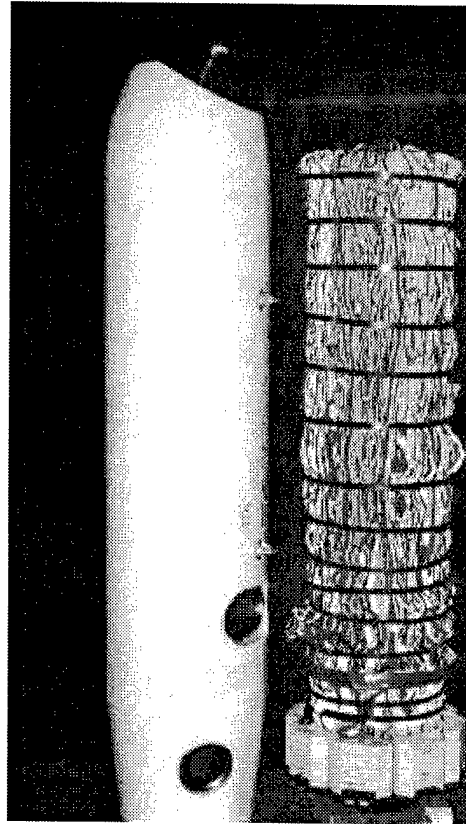


Figure 3 Packaged Array

Table 1. Drop Testing Results

Test No	Description	Execution	Results
A-1	8 fps velocity	No problems	100% coverage
B-2	18 fps velocity, surrogate material	No problems	95% coverage (fold back)
B-3	50 fps velocity	Premature impact, single rocket failure	55% coverage at impact
B-4	87 fps velocity	Single harness failure	65% coverage
C-5	40 fps velocity	Center support section interfered with array	100% coverage in air
C-6	300 fps velocity, surrogate array material	Fuse did not initiate rockets	Case split, but no test on array expansion
C-7	300 fps velocity, inert array material	Fuse initiated early	75% of net fully opened in air, center accelerated past edges, no coverage loss due to line damage
C-8	300 fps velocity, rockets 135 degrees relative to fall	Fuse did not cut array strapping material	Case split, good timing, no test on array expansion

A series, 51 ft diameter net, 8 rockets, 90 deg relative to fall direction, square mesh, 0.7 sec opening time  
 B-series, 100 ft diameter, 8 rockets, 90 deg relative to fall, herringbone mesh, 1.2 sec opening time  
 C-series, 70 ft diameter, 16 rockets, 45 deg relative to fall, herringbone mesh, 0.65 sec opening time

Full scale deployment tests on net sectors were conducted to finalize choice of a rocket motor for spreading the array.

The initial test series was conducted to demonstrate dynamic deployment of a net array for high drag type bomb systems. The final test showed the capability to deploy the net warhead at a descent rate approaching 100 fps.

A key design factor in any array design of this type is to minimize the drag of the system. Figure 4 shows an overhead view of drop B-4 which illustrates the tendril design of this array. The array does not spread fully until the rockets reach maximum extension. This approach significantly reduces the exposure time for the array to wind and drag effects, and produces an accurate, predictable deployment shape.

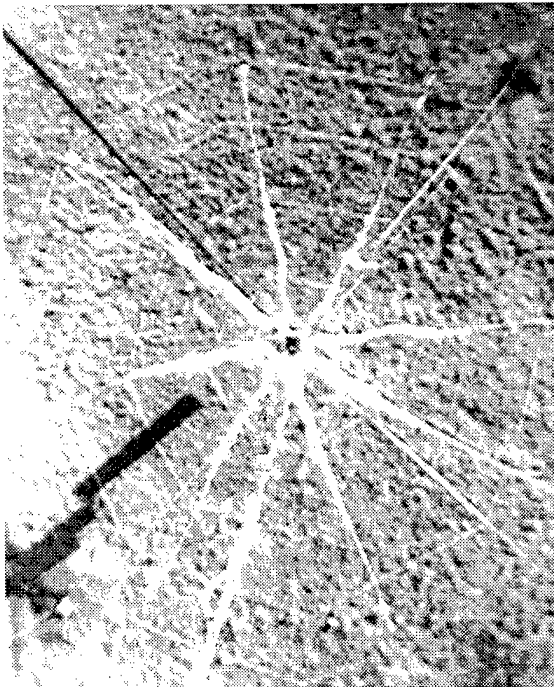


Figure 4 Overhead (from crane) Photo of Eight Rocket Array Deployment

As expected, a significant amount of axial drag was observed, but the rocket motors were, in most cases, able to expand the array prior to landing on the ground. The array did not fully expand due to a failure of one of the rocket motor harnesses. This failure caused that

section, as well as the adjacent ones, to experience an after-impact foldback that reduced the overall expansion to less than 70 percent. It is evident from the video records and post-test inspection, that the broken rocket harness was responsible for this result, and if the harness did not break, the array would have fully expanded.

The test results indicated the need to better understand the sensitivity of a single rocket motor failure on the performance of the system. Post test analysis made it apparent that a desirable feature would be to increase the number of rockets used to spread the array from eight to sixteen. This approach reduces the effect of a rocket failure impacting the total array final shape.

Analysis of the test results also indicated that it would be desirable to increase the rocket thrust/weight ratio above the 1.2 value used in the B-series tests. These factors, along with lessons learned with respect to packaging and array spreading, resulted in the C-series design which utilizes sixteen smaller rockets. The resulting design modification increased the systems overall thrust/weight ratio from 1.2 to 3.4. The design intent was to maximize power for opening the array quickly in a high drag flow regime, as planned in the C-series tests.

#### C-Series Tests

Completion of the B-series tests marked the next phase in the development process: to interface the array with a suitable bomb dispensing package. After review of several packages, assessing availability, and a desire to minimize reinventing known technology, the SUU-76 dispensing package was chosen as the baseline package for this phase

Internal volume in the SUU-76 (12" diameter, 64" length), results in a smaller baseline array size of 70-75 ft diameter, but the SUU-76 has the advantage of being an existing split case design and aircraft are capable of carrying more units per sortie than a Mk 65 design. The canister is split open by a linear shaped charge

which runs down the length of the canister at two locations.

Several SUU-76 canisters were obtained from scheduled demilitarization assets, and this allowed for interface and integration testing which are very meaningful in this phase of the effort.

Two critical tests were successfully executed prior to testing an integrated warhead at high speed from a helicopter drop. The first test was an interface test consisting of splitting the canister and looking for damage to the array. This test was successfully performed and no damage was found to the array system. This test indicated, as expected, that the linear shape charge did not transfer excessive pressure or loading to the array or the rocket assembly during the splitting process.

The second critical test (C-5) consisted of a repeat of the crane drop for the revised sixteen rocket configuration. The deployment sequence can be clearly seen in Figure 5. All rockets functioned well pulling the array evenly from its packaged state. The total time for array deployment, represented by the series of photos in Figure 5, is under one second.

The conical shape is due to the initial 45 degree downward launch angle and low drop velocity. This same shape is not expected at the higher operational velocities. The array perimeter velocity was measured from video at 110 fps while the center of the array was at 65 fps.

First order modelling and observing the data from scaled ballistic net tests (executed on an unrelated FMI program) determined that the 45 degree downward rocket configuration was ballistically preferred for promoting array 'flatness'. The models, however, are limited and have not accounted for rocket thrust biasing due to the rocket-bridle-net system relationship. The helicopter based, operational speed test goals are to validate the modelling accuracy and ultimately determine the optimal rocket angle to maximize system coverage.

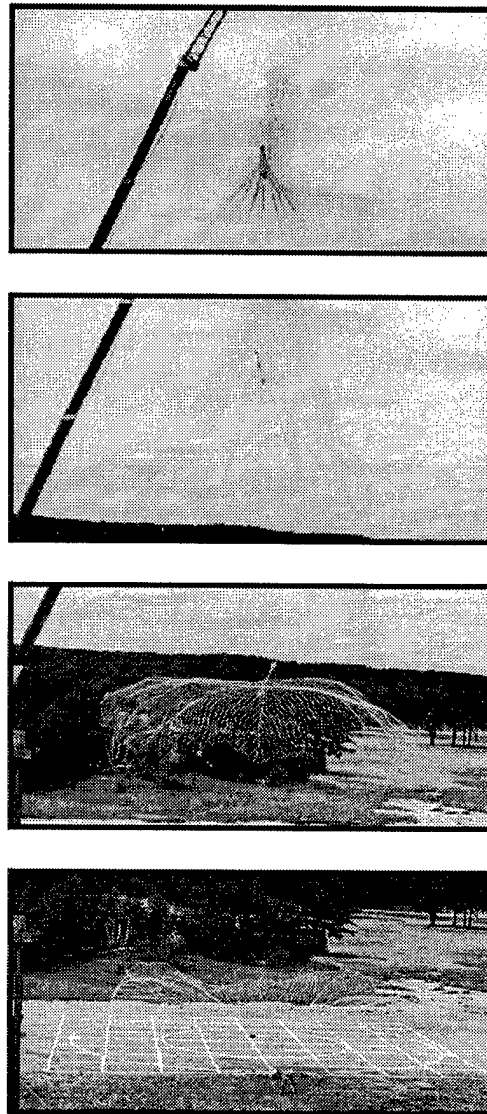


Figure 5. Deployment Sequence

#### Helicopter Drop Tests

The most recent tests, C-6 through C-8, are being executed as a partially integrated package deployed from a commercial helicopter. The array is packaged inside a SUU-76 munitions canister and dropped from a height of 2000 ft. The package free falls to achieve operational velocities and at a predetermined time interval the system is fused to deploy the array. The fuse initiates the firing sequence of the linear



shape charge, splitting the canister, and after a delay initiates the rockets to deploy the array.

In the tests performed to date, all of the elements necessary for a successful deployment have been demonstrated, however, all of the elements have not been demonstrated on the same test.

Significant components which have been demonstrated include:

- Split case does not interfere with net deployment
- The perimeter rockets supply sufficient power to the array perimeter to overcome the operational speed induced drag
- Damage to the physical material of the fragile net (inert explosive simulant) was minimal and would not effective explosive coverage. This indicated that the array could absorb the forces without destroying the integrity of the explosive train.
- The array opens at least 30% faster in the high drag tests (<0.5 sec) than in the low drag test (0.65 sec).
- The vertical standoff required to completely open the array at 300 fps is less than 100 ft above ground level.

It is clear that even in this high drag regime the rockets are able to extract the array very quickly and uniformly. This allows for deployment close to the ground which reduces net distortion from environmental effects. The next step in the program is to further modify the net perimeter design to maximize coverage over the band of operational velocities.

### Conclusions

The Thunder Road project has successfully demonstrated deployment of large array systems which could be used for mine clearance missions, or other low collateral damage scenarios. Testing from a weapons canister shows significant progress. Further testing is necessary to resolve issues and obtain full deployment potential.

The Thunder Road technology gives the Navy and Marine Corps another option for surf zone mine clearance. The ability which Thunder Road provides; fast, flexible response to the changing battlespace, will be a key component to the ultimate success of the expeditionary warfare mission.

### Acknowledgments

This work was funded by the Office of Naval Research, Dr. Thomas Swean, Code 321.

### Supporting Organizations

Several organizations have been instrumental in supporting this effort and include:

- NSWC IHD (Kevin Gessner) developed a dynamic model of the array deployment for design use and tradeoff studies,
- NOCPACDIV (Debra Dock) and NAWC-Pt Mugu (John Durda) facilitated acquisition of SUU-76 canisters,
- FT DEVENS range support provided an excellent working environment, and support for conducting these tests.

### References

1. M. Farinella et al, "Surf Zone Mine Neutralization Program (Thunder Road) Interim Report", January 1996.
2. Knacke, T.W., "Parachute Recovery Systems". Design Manual.
3. M. Farinella, Monthly Progress Reports for Contract N60921-93-C-0069.

# **Explosive Neutralization Techniques**

**Les Taylor**

Naval Surface Warfare Center

Indian Head Division

Naval Sea Systems Command

---

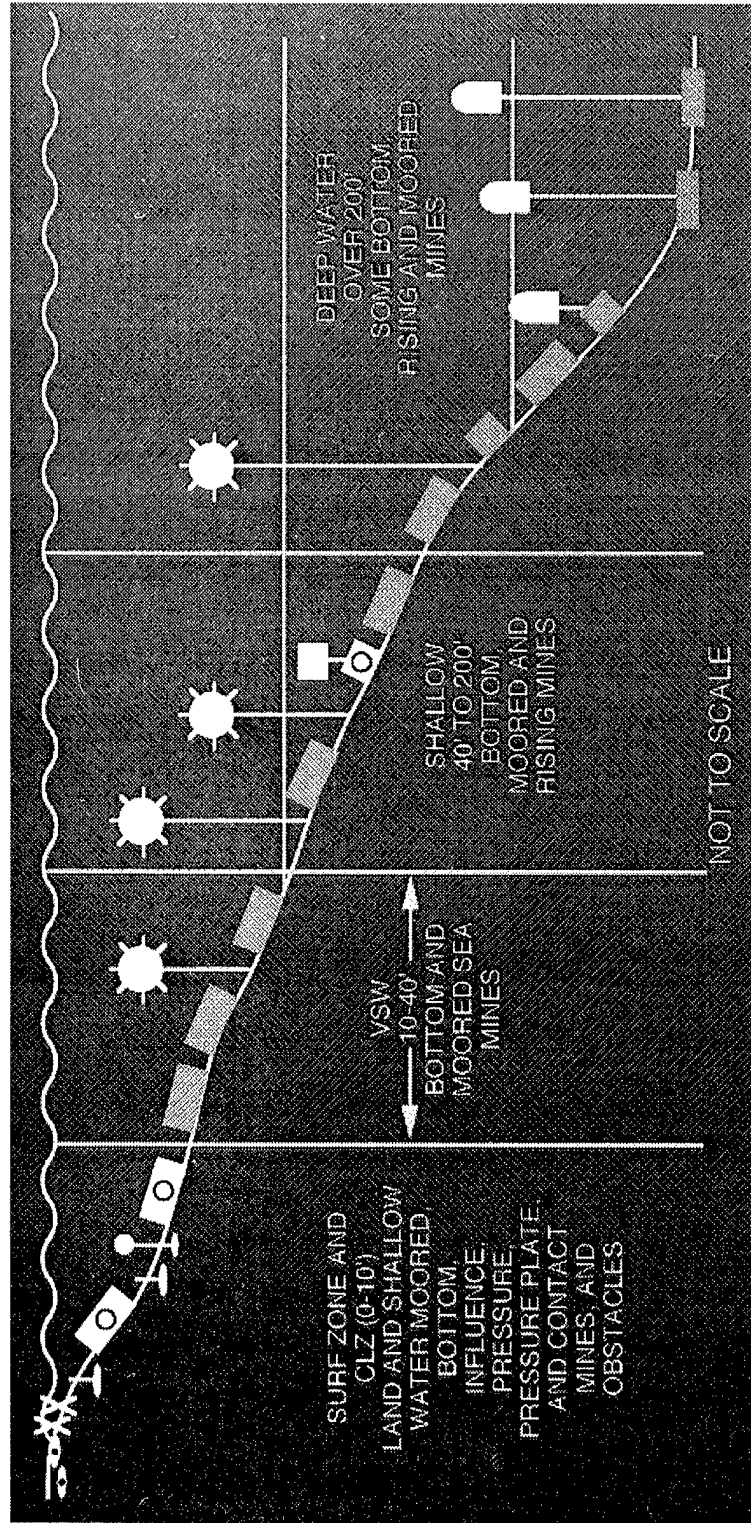
# Purpose

- Overview of technology being developed by Navy to understand explosive effectiveness of
  - Bombs and bomblets
  - Line charges
  - Explosive arrays
  - Shaped charges
  - Explosively formed projectiles/CRW/KE in neutralizing mines and destroying obstacles

---

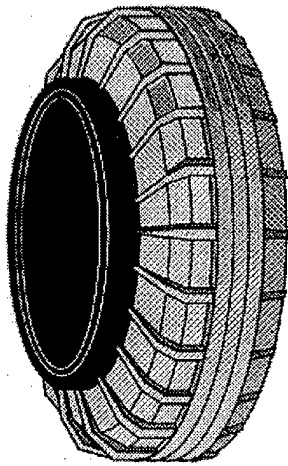
*Explosive Neutralization Effectiveness*

# Threat Regimes

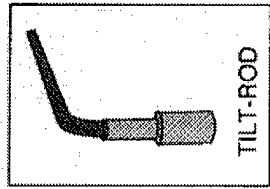


*Explosive Neutralization Effectiveness*

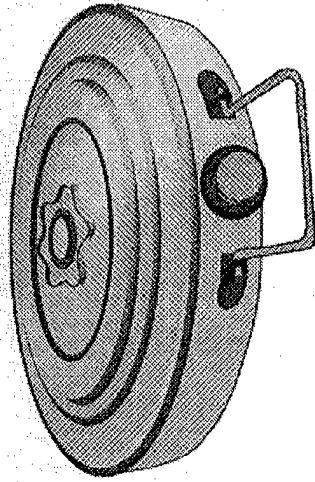
# Mine Threat



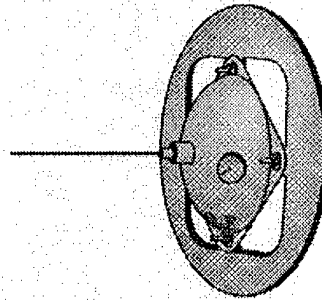
ITALIAN VS-1.6 SCATTERABLE AT MINE  
OVERALL/WARHEAD WEIGHT (Kg): 3.0/1.85  
DIAMETER: 22.2 cm



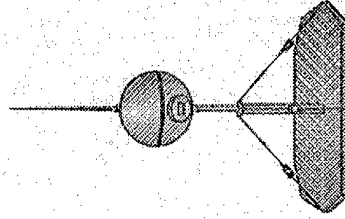
TILT-ROD



SOVIET TM-46 AT MINE  
OVERALL/WARHEAD WEIGHT (Kg): 8.6/5.7  
DIAMETER: 30.5 cm



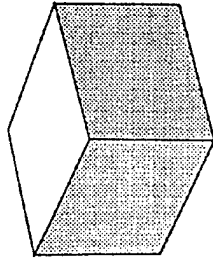
RUSSIAN PDM-1M ANTI-INVASION SURF ZONE BOTTOM MINE  
OVERALL/WARHEAD WEIGHT (Kg): 60/10  
DIAMETER: 80 cm



RUSSIAN PDM-2 ANTI-INVASION SURF ZONE MINE  
OVERALL/WARHEAD WEIGHT (Kg): 100/15  
DIAMETER: 27 cm  
OVERALL HEIGHT: 1.4 - 2.7 m

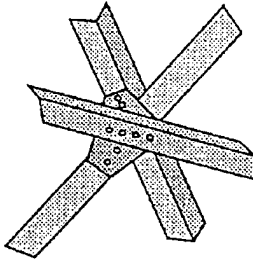
*Explosive Neutralization Effectiveness*

# Obstacle Threat



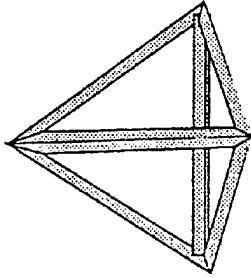
**CONCRETE CUBE**

- 4X4X4 FT SOLID CUBE
- 3000 PSI CONCRETE
- WEIGHT APPROX. 5 TONS



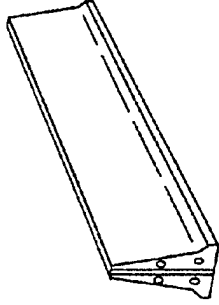
**STEEL HEDGEHOG**

- 4X4X3/8 INCH ANGLE IRON
- EACH LEG 4 FT LONG
- BOLTED OR WELDED



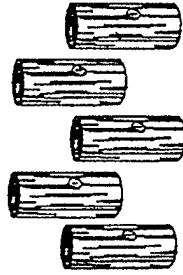
**STEEL TETRAHEDRON**

- 4X4X5/8 INCH ANGLE IRON
- EACH LEG 5 FT LONG
- WELDED



**JERSEY BARRIER**

- REINFORCED CONCRETE
- 12 FOOT LENGTH MINIMUM
- 2.75 FOOT TALL



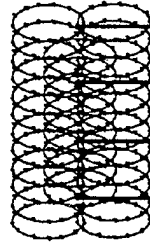
**LOG POSTS**

- 30-48 INCHES ABOVE GROUND
- MINIMUM 18 INCHES DIAMETER
- 5 FT BURIAL
- HARDWOOD LOGS OR TELEPHONE POLES

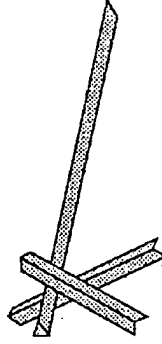


**SINGLE CONCERTINA**

- 36 INCH DIAMETER (EACH ROLL)
- MOST COMMON AS TRIPLE STANDARD CONCERTINA
- STEEL ENGINEER STAKES EVERY 12.5 FT



**TRIPLE STANDARD CONCERTINA WIRE**



**ENGINEER STAKE JACK**

- 6 FT ENGINEER STAKES CROSSED AT 60 DEGREE AND SPOT WELDED
- 12 FOOT ENGINEER STAKE SPOT WELDED ON TOP OF CROSSED STAKES
- 4.3 FT HIGH, 5 FT WIDE, 12 FT LONG

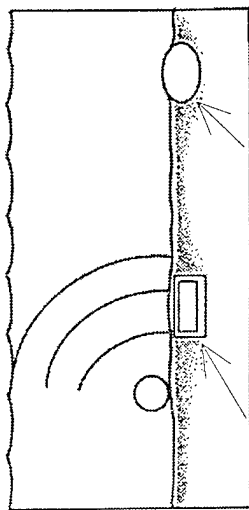
*Explosive Neutralization Effectiveness*

# Comparison of Explosive Devices

## Line Charge

Similar to bomblets except cylindrical spreading loss rather than spherical

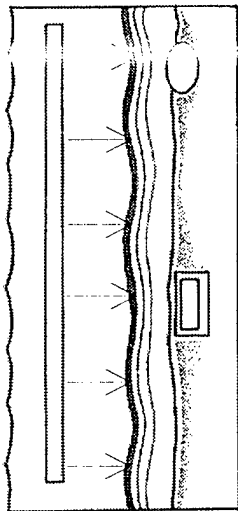
## Bombs/Bomblets



Buried A.T. Partially Buried Bottom Mine

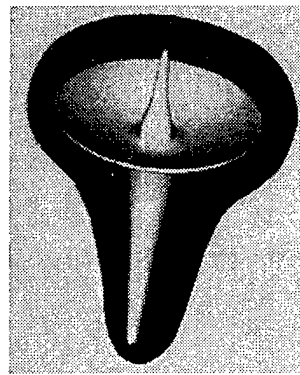
- Spherical geometric spread

## Distributed Explosives Blanket Type Charge



Shock Wave

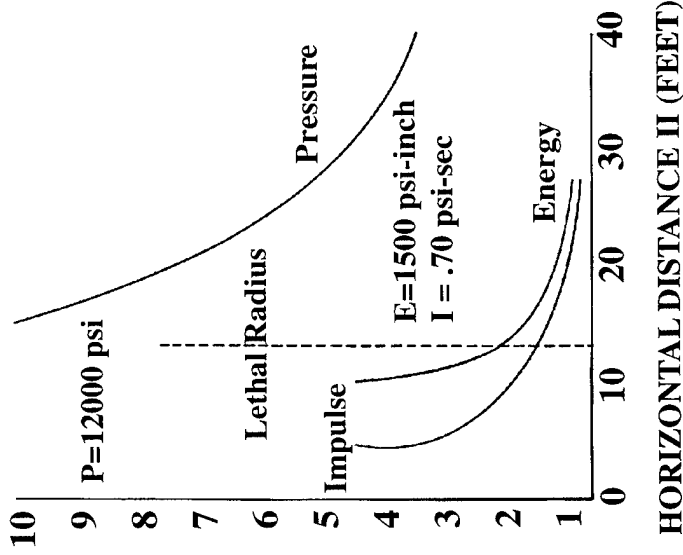
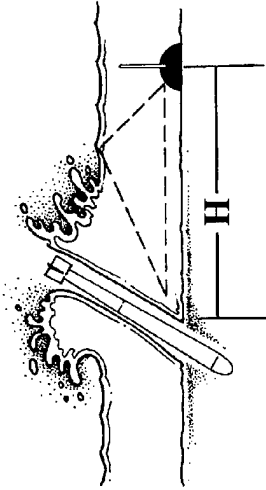
- Minimum attenuation
- Good transmission of shock in water



## *Explosive Neutralization Effectiveness*

# MIK 83 Bomb Effectiveness in Surf Zone

PRESSURE 1000 psi  
 IMPULSE psi-sec  
 ENERGY 1000 in-lb/N<sub>2</sub>



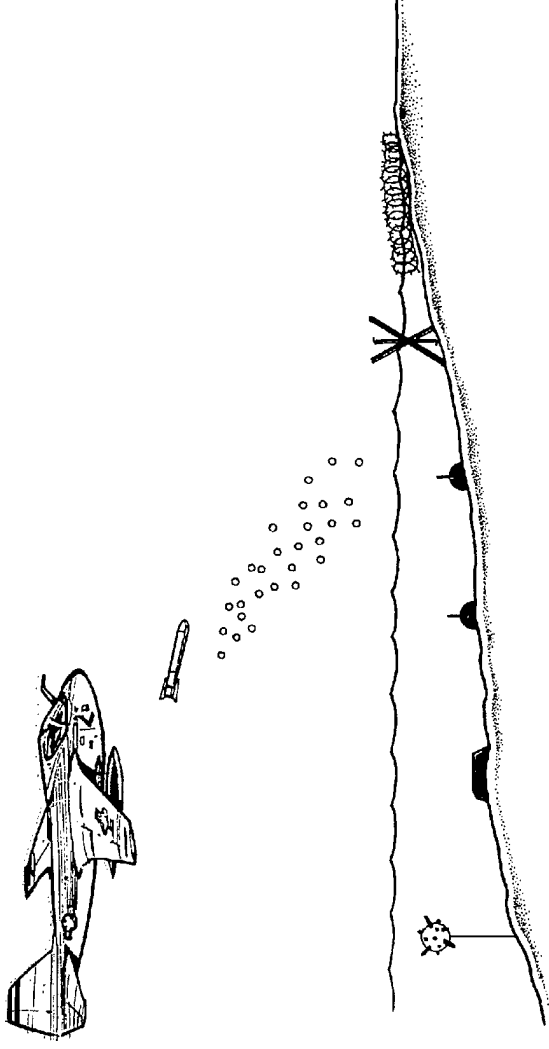
- Bombs more effective against mines in water than air, but surface cutoff in surf zone reduces impulse, energy

*Explosive Neutralization Effectiveness*



---

# Bomblets in Surf Zone and on Beach



- Less than half the weight of general purpose bombs is explosive
- Bulk of weight in bomblets can be explosive
- Bomblets are more effective against mines than bombs based of lift, but still requires large numbers due to random hit distribution

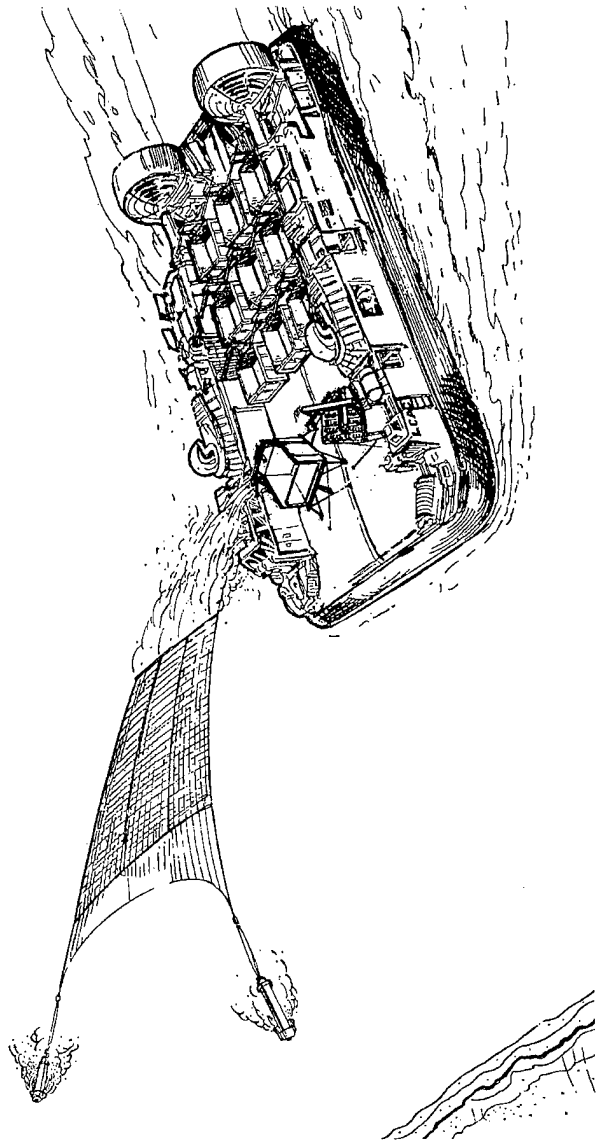
---

*Explosive Neutralization Effectiveness*

---

# Distributed Explosive Technology (DET)

---



- DET effective against mines in very shallow part of surf zone up to high water mark.

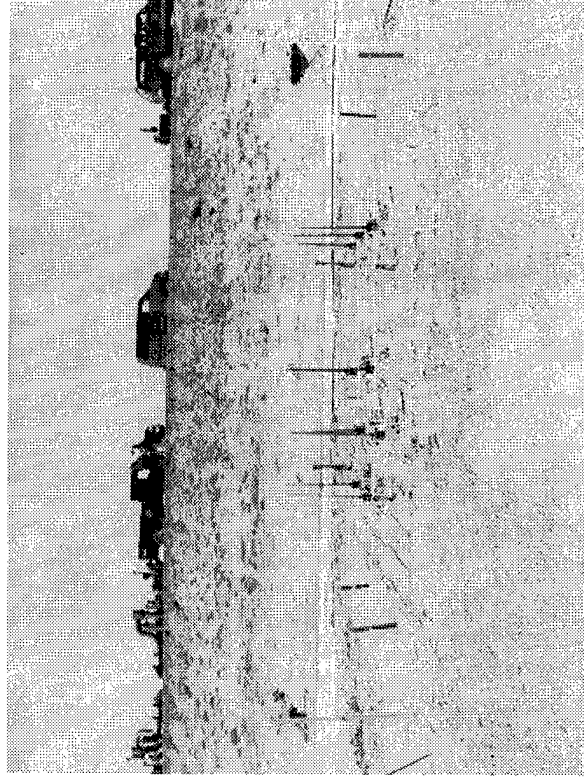
---

*Explosive Neutralization Effectiveness*

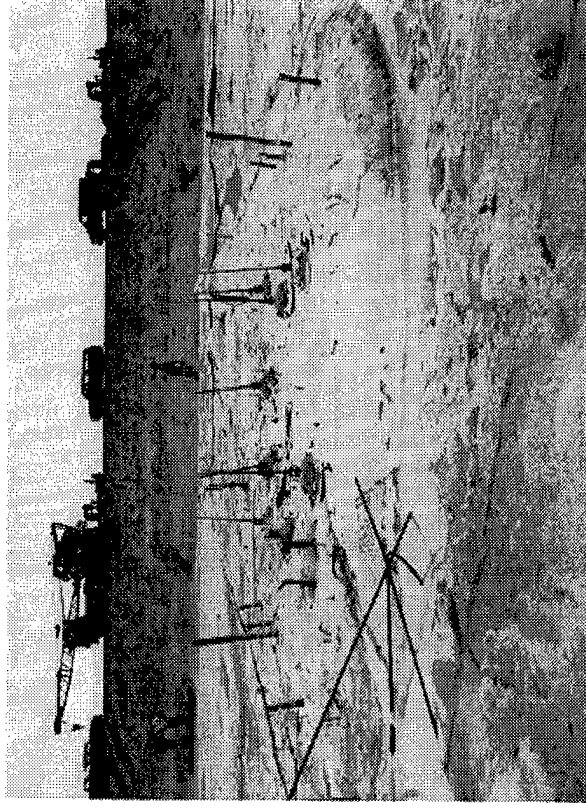
---

---

# DET Test



**Test Setup**



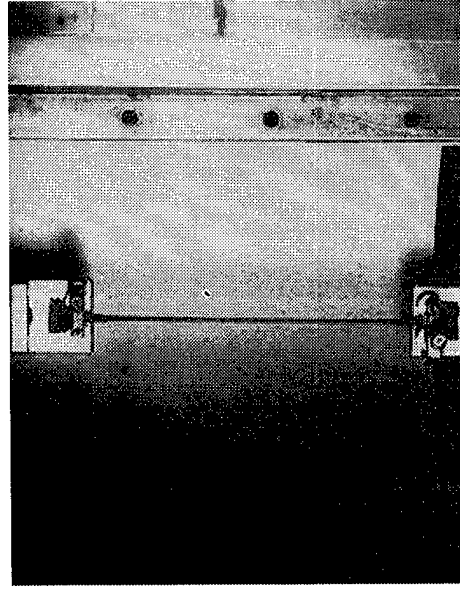
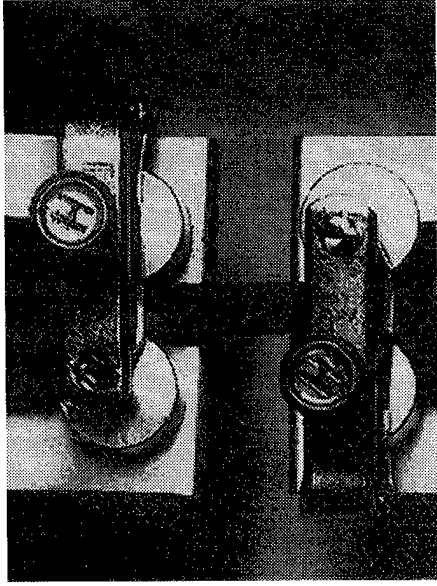
**Result**

---

---

*Explosive Neutralization Effectiveness*

# Tough High Performance Explosive for MCM Explosive Arrays



- 15% greater shock that SX-2
  - Increased areal coverage
- 500% elongation
  - Improved survivability and packaging
- Smaller (< .1”) failure diameter

*Explosive Neutralization Effectiveness*

---

# Improved Explosives

- Current explosives in service

	<u>Shock</u>	<u>Bubble</u>
- H-6	1.3 TNT	1.7 TNT
- PBXN-103	1.7 TNT	2.3 TNT
- SX-2
- Det array
- 1.2 TNT
- 1.0 TNT
- New explosives in development

- ADN/AP/alum	Improved SABRE	1.7 TNT	3.0 TNT
- SMX-13	Improved DET	1.4 TNT	1.6 TNT
- **Technology goals**
  - Increase shock near term 20% - increase over PBXN-103
  - Increase energy release - 2 times PBXN-103
- Issues - IM and critical diameter for line charge

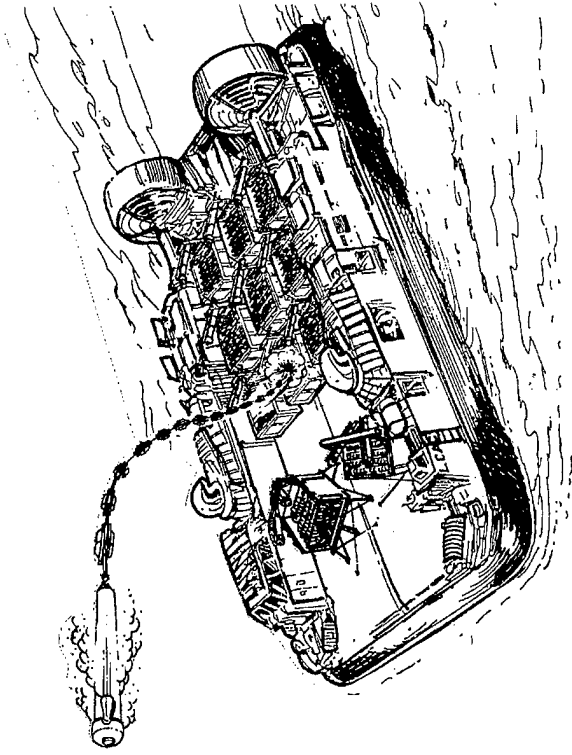
---

*Explosive Neutralization Effectiveness*

---

---

# Shallow Water Assault Breaching System (SABRE)



- Line charge under development found to be effective against anti-invasion mines and light obstacles in surf zone

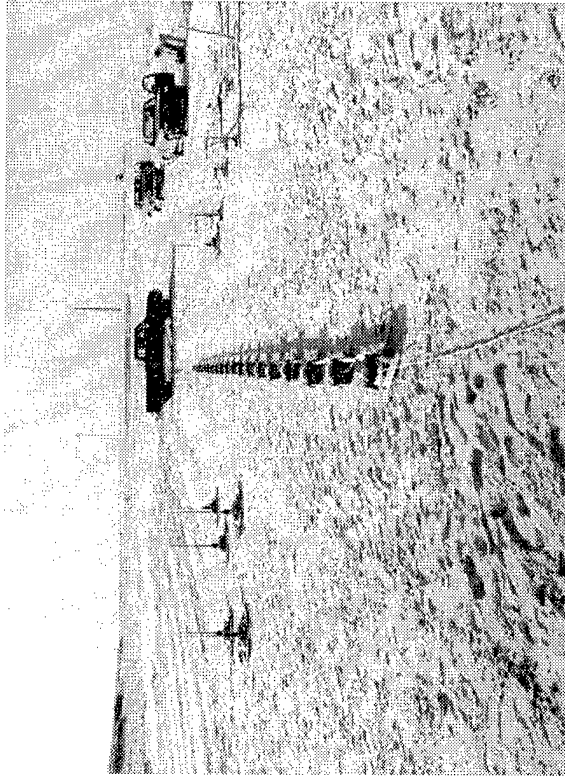
---

---

*Explosive Neutralization Effectiveness*

# Line Charge Test

Test Setup

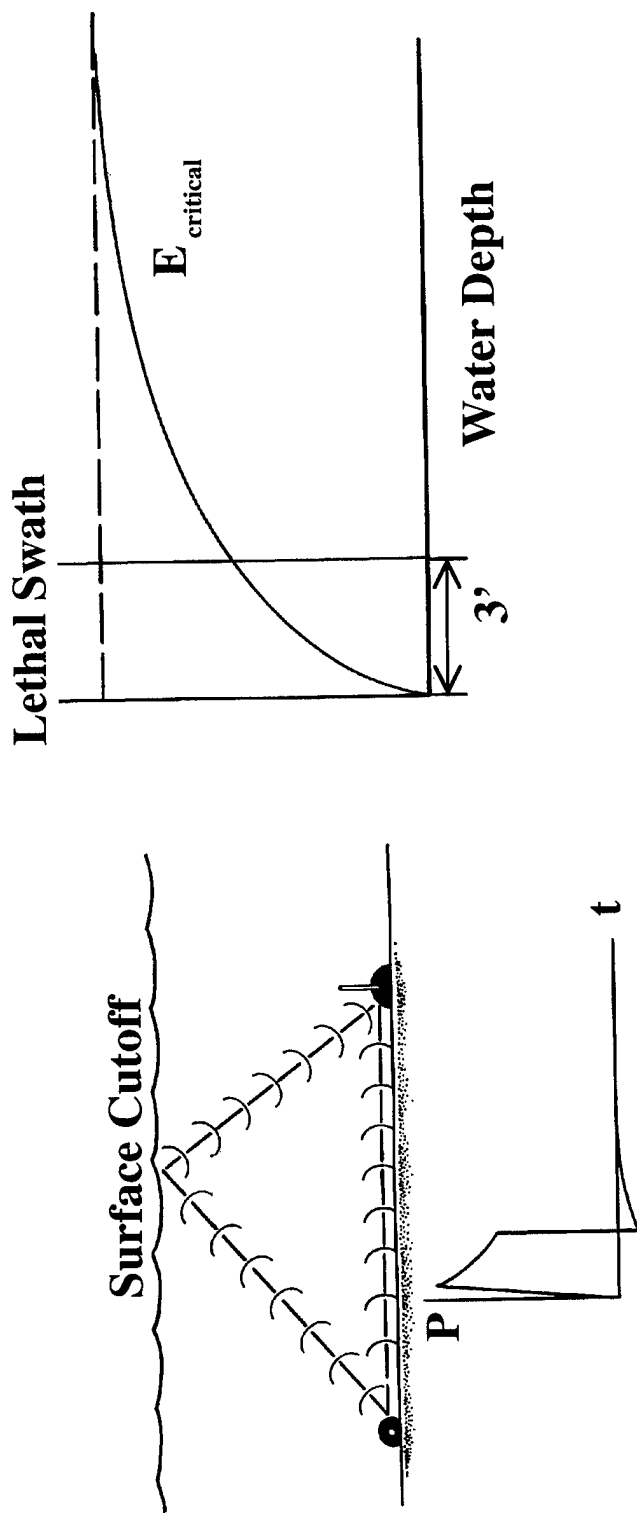


Result



*Explosive Neutralization Effectiveness*

# Line Charge Shock Wave in Water



- Line charge most effective against mines in water depth greater than 3 feet

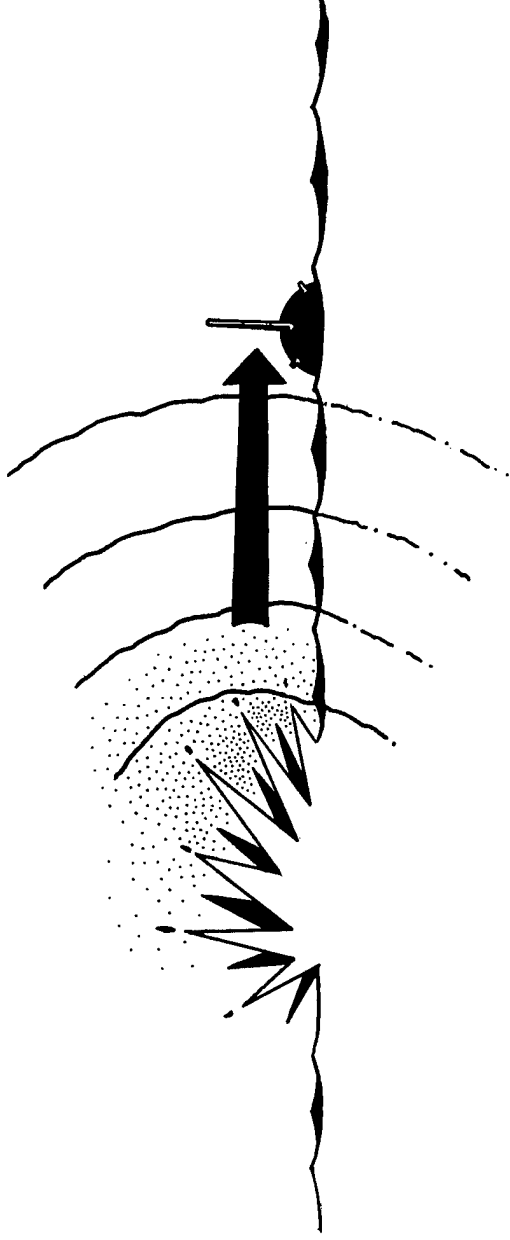
*Explosive Neutralization Effectiveness*



---

---

# Line Charge Bubble Effects



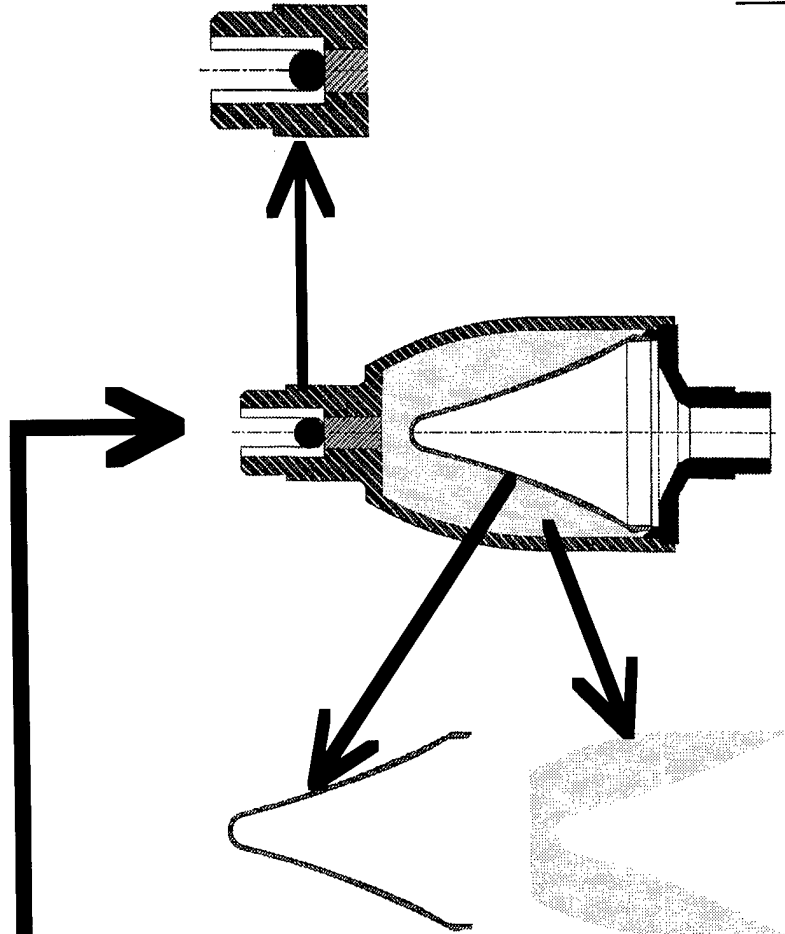
- Flow velocity from bubble causes hydrodynamic force  
 $F = 1/2 \rho v^2 C_D A$  ↓
- Hydrodynamic force can be sufficient to actuate fuze of some mines

---

---

*Explosive Neutralization Effectiveness*

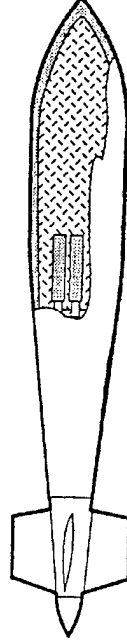
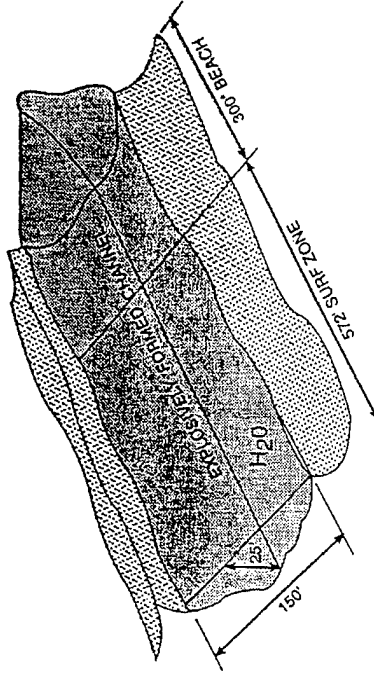
# Beach Zone Array



*Explosive Neutralization Effectiveness*

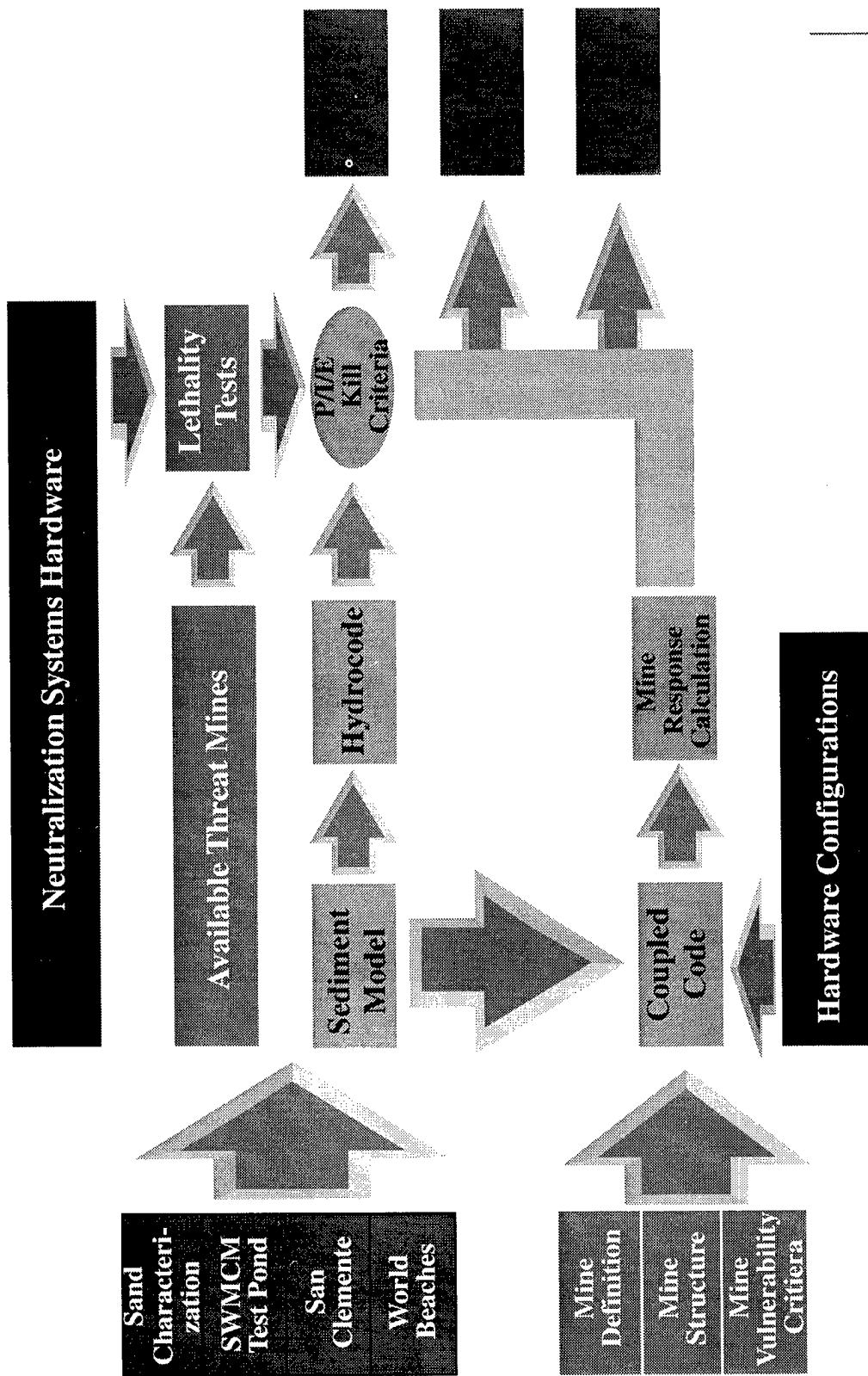
# Simultaneous Detonation of Big Bombs

- Channel formed by simultaneous detonation of 10,000 lbs (equiv. TNT) bombs (16 bombs, spaced 60 feet in line, 8-B-52 sorties)
- World War II  
12000 lb.,  
Tallboy bomb  
38" diameter  
252" long
- Big bombs do not exist in U.S. inventory
- Smaller bombs at closer spacing may be effective



*Explosive Neutralization Effectiveness*

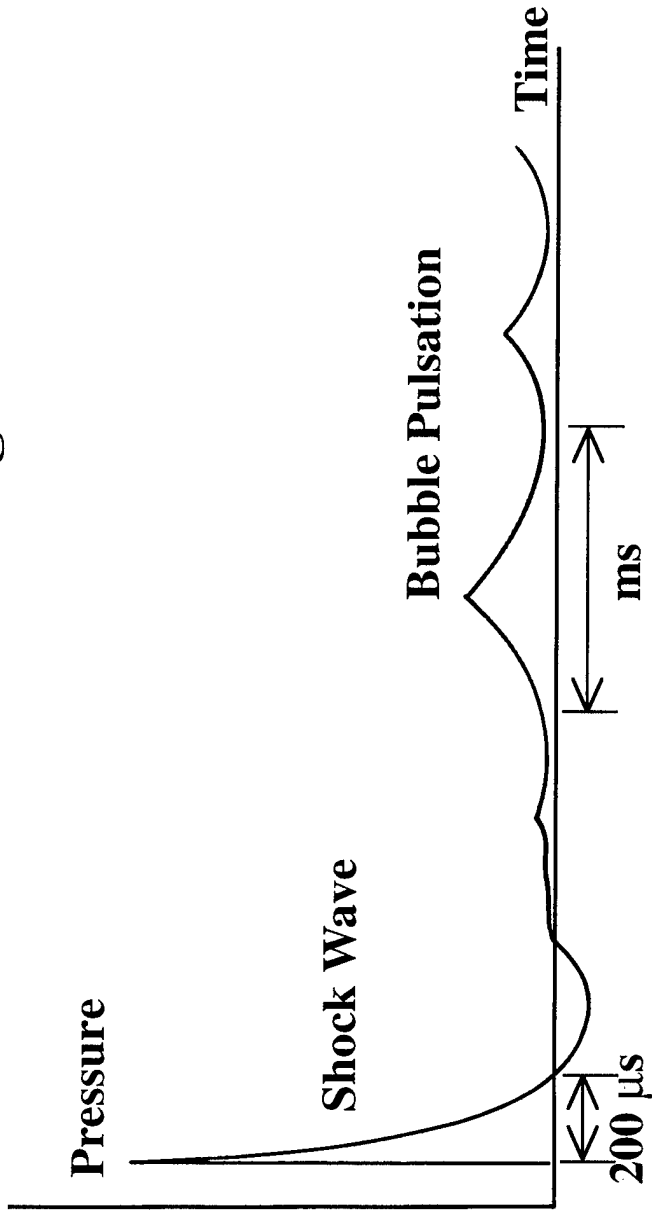
# Performance Evaluation



*Explosive Neutralization Effectiveness*

# Explosive Energy Partitioning

## Bulk Charge



- Energy is distributed approximately equally between shock wave and bubble pulsation from explosive gas products

*Explosive Neutralization Effectiveness*

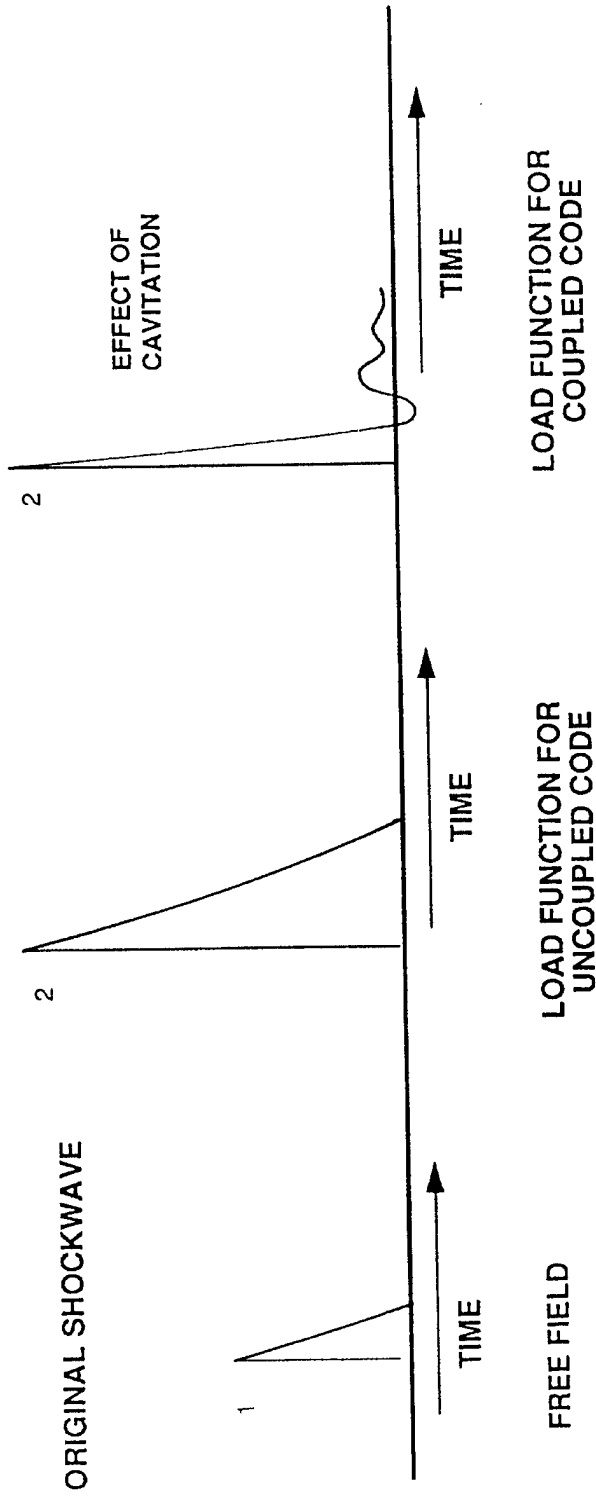
# Modeling Fluid Structure Interaction

## Issues

3D: FLOW FIELD ASYMMETRIC TO TARGET GEOMETRY

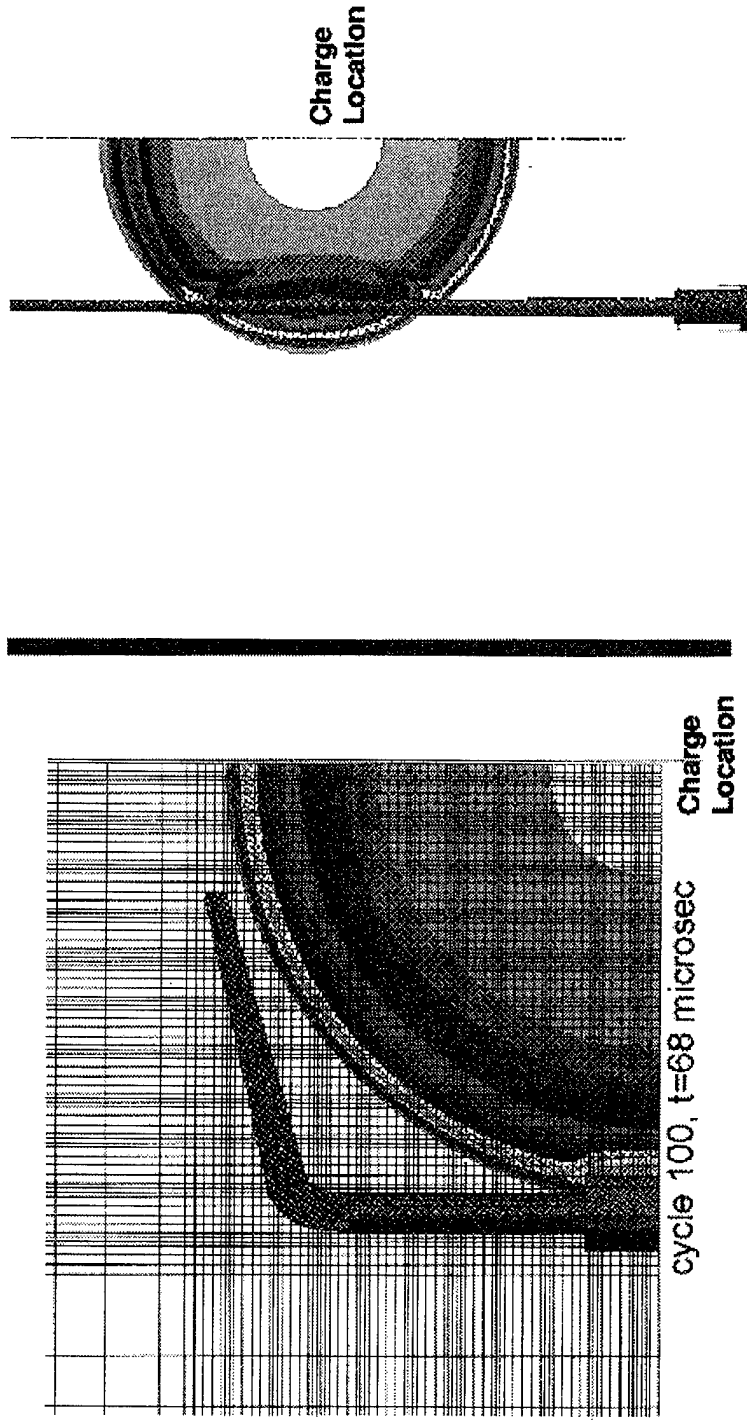
COUPLED CODE: FLUID STRUCTURE INTERACTION

    PRESSURE ON RIGID TARGET      PRESSURE ON REAL TARGET  
    NO FLUID STRUCTURE INTERACTION      FLUID STRUCTURE INTERACTION



*Explosive Neutralization Effectiveness*

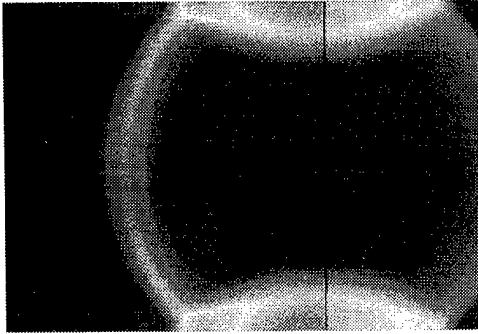
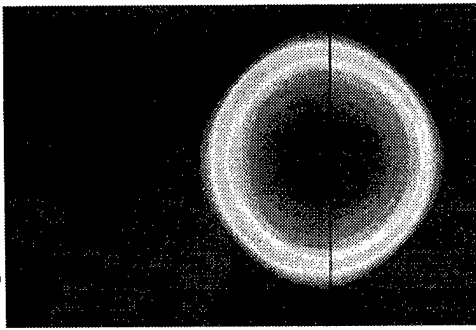
# Modeling Fluid Structure Interaction



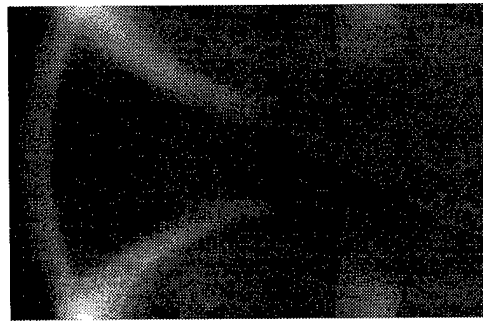
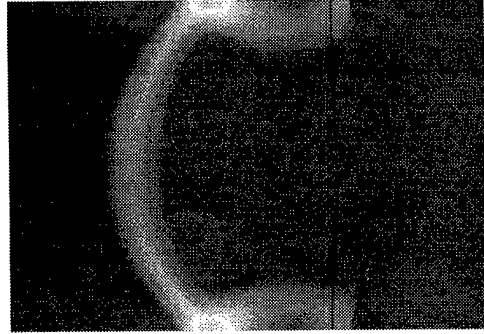
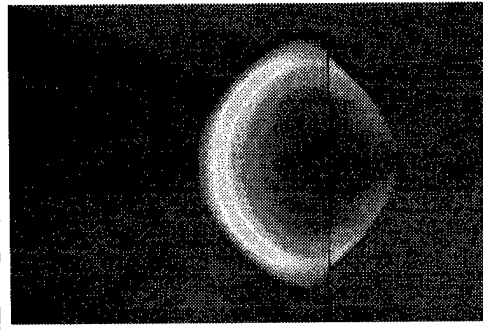
*Explosive Neutralization Effectiveness*

# Modeling Sediment

0% Air Content



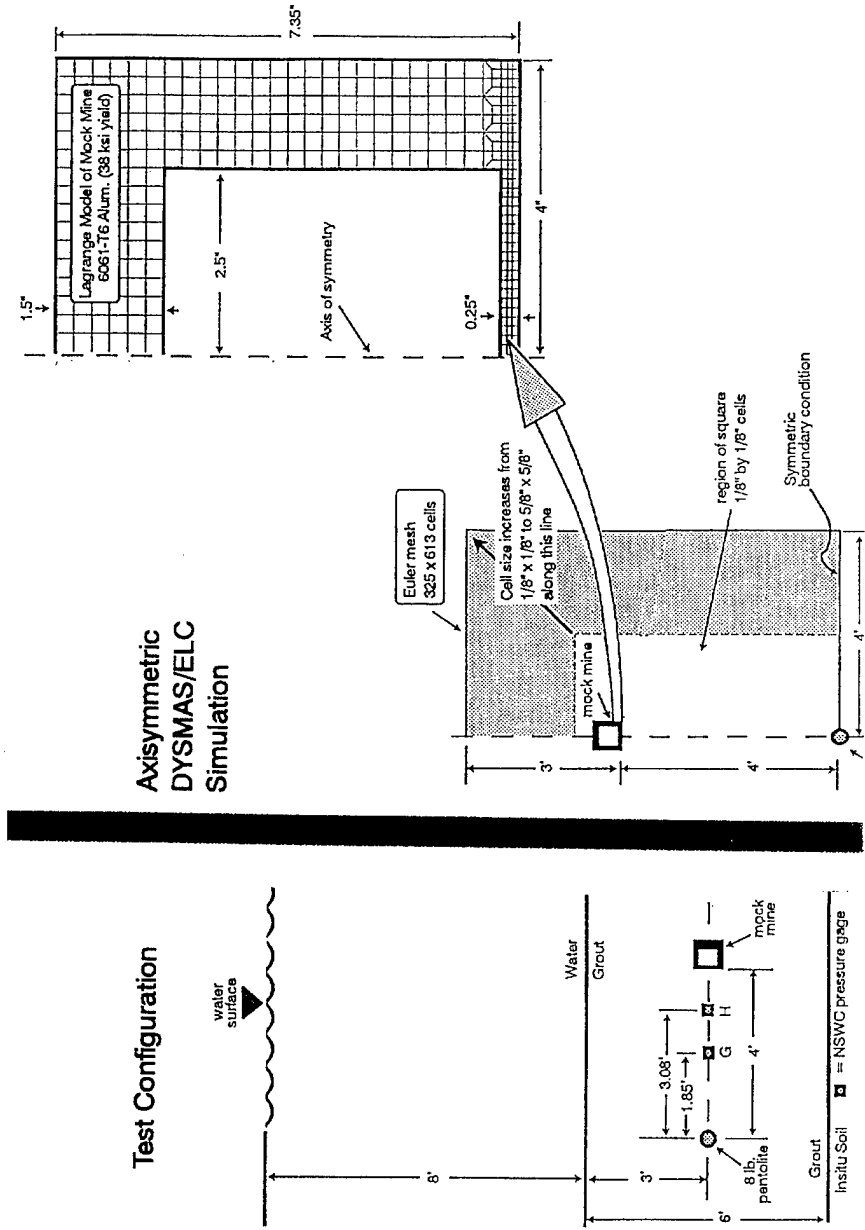
5% Air Content



*Explosive Neutralization Effectiveness*

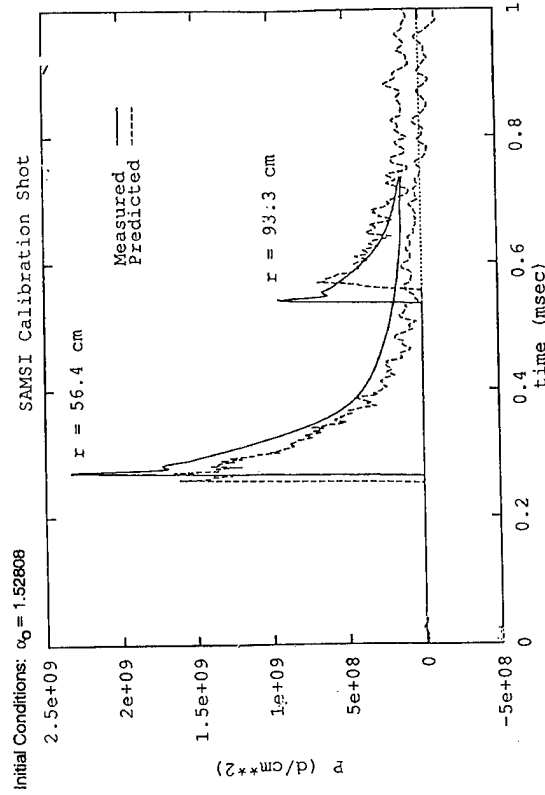


# DYSMAS/ELC Simulation of SAMSI Test

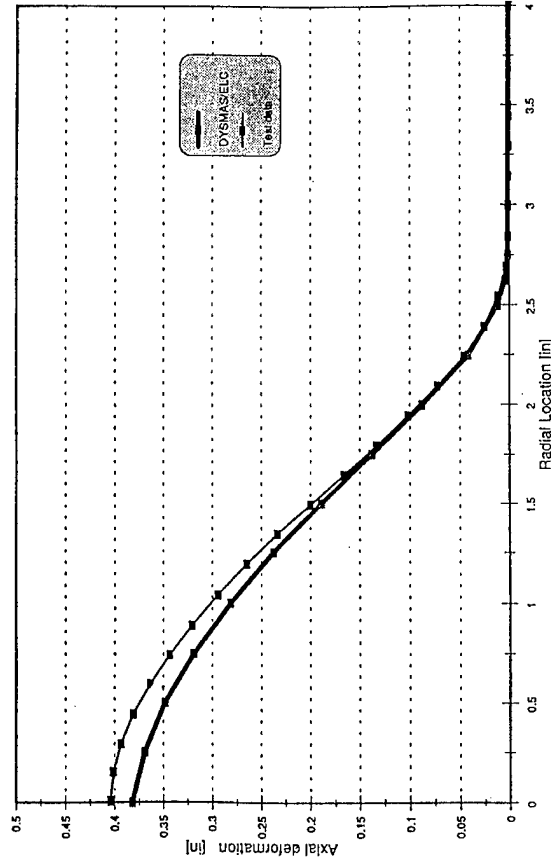


*Explosive Neutralization Effectiveness*

# DYSMAS/ELC Simulation of SAMSI Test



Predicted vs Measured Pressures



Predicted vs Measured Deformation

*Explosive Neutralization Effectiveness*

---

---

# Summary

- Explosive systems provide brute force approach for breaching mines and obstacles in the surf zone
  - Line charges and explosive arrays are complimentary in minimizing lift and cube
- Shaped charges effective for sympathetically detonating proud/buried mines on the beach
- EFP effective for breaching concrete obstacles
- Simultaneous detonation of bombs under investigation for creating channel by ejecting mines and obstacles
- Modeling and simulation being developed to
  - Design and evaluate explosive systems to neutralize new threats that emerge
  - Minimize costly vulnerability tests

---

---

*Explosive Neutralization Effectiveness*

**Pulse Power -  
21st Century Platform Defense  
for Mines and Torpedoes**

**RADM Charles F. Horne III, USN (Ret)**

SC-21 and other U.S. Navy surface combatants for the 21st Century must have inherently and organically effective and affordable self defense against mines and torpedoes! At least three well respected American defense corporations are developing pulse power technologies which may well provide this organic and effective self defense for the Navy's 21st Century platforms.

When the USS PRINCETON (CG-59) was ordered in to perform close in-shore fire support during Desert Storm, she had no such organic self defense against mines. Further, there were no options to wait for MCM ships or helicopters to toil at making a safer ingress and egress. Sure enough, PRINCETON hit a mine on egress which caused millions of dollars' worth of damage and extended off-line repairs.

Needed

What is needed is that our future platforms, particularly surface combatants, have their own inherent effective and affordable MCM and torpedo defense. To be effective, the system or device must be able to destroy the mines and torpedoes outside of their lethal range and with 100% or near 100% kill of each relevant mine/torpedo. To be affordable, the system must not be based on sonars and sensors which require considerable manpower

(and therefore cost) for searching and classification and only afford far less than 100% probability of kill. What is needed is something that will beam out and ahead and crush the incoming torpedo and mine or mine-like object whenever the organic system is turned on as the ship must steam into harm's way! As opposed to searching, classifying and attempting to neutralize with sensors - an overriding beam neutralizes all in its path - mines, rocks or mine-like objects!

#### Pulse Power

In layman's terms, pulse power is the creating in water of focused impulses up to 30,000 lbs. per square inch, each second, that travel through water and crush mines or torpedoes. Through repeated impulses, they can even disintegrate concrete blocks and render other obstacles ineffective. These pulses can be created electrically and/or chemically in a phased array of cylinders that help magnify and direct the pulses of power through the water medium to the targets.

#### Recommendation

Accordingly, it is respectfully and most ardently submitted that the SC-21 and other Navy surface platforms for the future not have a man-intensive search system - but a relatively fool-proof mechanical system to go into "harm's way" - regional conflicts where mines and torpedoes will be the Third World opponent's weapon of choice!

What is recommended is that the Naval Studies Platform Panel as well as the Navy (NAVSEA, ONR, N86, N85) and DARPA grab hold of and develop and refine pulse power for "Forward...from the sea," just as radar was embraced and developed during World War II for combat at sea.

There are at least three defense companies - Vail Research and Technology (Capt. Mike Jerome ret. 703-642-0901), E-Systems of Raytheon (Dr. Shyke Goldstein 202-223-8808) and United Defense of FMC (RAdm. Bill Fogarty ret. 612-572-6572) - who are briefing ONR and DARPA and 1 August 1996 on their ready to test "proof of concept" of pulse power for organic underwater defense. They are ready to brief other interested organizations and study groups.

It is understood, for the reasons outlined, that the N85-N86 teams are very interested in exploring and developing pulse power for MCM and torpedo defense. So also is the Program Manager and his team for the SC-21. It is respectfully recommended that all of us - who can be helpful in this vital area of effective organic self defense in regional conflict for the Navy's platforms for the future - do all we can to insure pulse power gets the same constructive development that radar did for world conflict.

Charles F. Horne III  
Rear Admiral, U.S. Navy ret.

Member of the Naval Studies Board  
Panel on Platforms, Technology  
for Future Naval Forces



## **Is the Application and Utilization of all the Required Skills Being Applied within the Mechanical Mine Clearance Arena?**

**William N. Baker**

**Clausen Power Blade, Inc., Systems Ingetration**

The statement, "Technology has not caught up with the problem" is often made within the mine countermine arena. Maybe it is not that technology has not caught up, but that we have not addressed the application of all the required combined skills as being part of the solution.

I would like to use a number of analogies to communicate this dicipline in the approaches to the mechanical mine clearance arena.

One of these analogies pertains to The Aircraft Industry, the crown jewel of American industry. During post World War II the Douglas Aircraft Company made a decision that they would manufacture only commercial propeller aircraft, where as the Boeing Aircraft Company made a decision that they would manufacture a commercial jet aircraft. This was a high risk decision.

However, Boeing understood that all related skills needed to be included in their planning to deliver and produce a marketable product. This marketable product became the 707 commercial jet airliner and the military variant, the KC-135 air refueling tanker. As a result of this decision, Boeing became significant leader in the world's aviation industry.

Another analogy relates to the auto industry. There was a saying in Detroit "What is good for GM is good for the USA." However, in the 70's, that was not the case. GM had lost touch with the consumer.

As we know, GM has regained a good portion of the market they lost. However, before recovery could take place GM had to recognize that all related skills needed to be addressed and included in their planning to be successful and competitive. The blue collar assembly worker was one of those required combined skills and his feedback and experience was critical in GM's recovery.

When Iacoca went to Chrysler he found that there was inadequate communication between engineering and manufacturing. As an example, if there was a design problem



---

or some other problem in the engineering manufacturing relationship, the engineer might have the ability to come up with a terrific new design. However, there was one problem: He did not know the manufacturing people could not build it. Why? Because he never talked to them!

As Iacoca stated in his autobiography, “People in engineering and manufacturing almost have to be sleeping together; these guys weren’t even flirting!”<sup>1</sup> Another example at Chrysler was the manufacturing guys were building cars without checking with the sales guys. They just built them, stuck them in a yard and hoped somebody would take them out of there. In the end, Chrysler had a huge inventory and large financial loss. Turnaround was when they learned to utilize all the required skills.

Another example was my own experience in the Air Force. As a systems integration program manager, we would review time lines of ongoing programs. During these reviews the Director would make this statement, “Gentlemen, are we designing a solution or a “career term” program?” His position was that, if a program was long term, you better have all the required skills. He did not believe going down road for 5 to 10 years and coming in with no results. He believed in accountability. We constantly reviewed programs to ensure we had all the skills required to define and execute the programs.

During my five year involvement in the mechanical mine clearance arena, one critical skill has been missing. That skill is the science and art of earth moving. I am not talking about an individual jumping on a dozer and plowing and pushing dirt. I am talking about the science and art of earth moving.

The science of earth moving consist of a combination of the technology of earth moving mechanics and the knowledge and capabilities of earth moving equipment as it responds to various types of soils and soil conditions. The art of earth moving requires sustained proficiency.

During the same time (in the past 5 years), I have heard the same buzz words “Nothing has changed in the mechanical mine clearance since W.W.II.” This statement is a license to fail and reinforces the position that some of the required skills are missing, not recognized, or being ignored, in defining, designing and executing solutions in the mechanical mine clearance arena.

The driving forces in industry are competition and financial success. Industry has learned that it is essential that they apply the principal of the application and utilization of all required skills to be competitive and successful. The government is crisis driven and

---

the only time significant government effort seems to be applied to mine clearance measures is when individuals are at immediate risk of being maimed or killed such as Dessert Storm, Somalia, Bosnia, etc. Following the crisis, the outcome is always the same. Broad area announcements are submitted to industry soliciting information, a period of no results and finally the initiative dies on the vine.

As a final illustration, we brought an earth moving technology, the Clausen Power Blade, that we had developed for the pipeline industry into mechanical mine clearance community and have produced successful results that have never before been attained in the mechanical mine clearance arena.

To develop solutions in the mechanical mine countermine program we must have the ability to recognize, collect, and utilize all of the related skills required for a successful result.

You can have the technologies and concepts but if you do not have the required combined skills to apply these technologies and concepts your end result will be repetitive research that demonstrates continuous failure of application.

REFERENCE:

1. Lee Iacocca, *Iacocca: An Autobiography*, Bantam Books, Inc., New York, NY, 1984., p. 153



# **Alternative Approaches to Minesweeping and Mine Clearance**

**Warren Loughmiller**

Naval Surface Warfare Center, Crane, Indiana

## **INTRODUCTION**

Rapid mine clearing technology is a priority Marine Corps program resulting directly from Operation Desert Storm after action reports. Mine fields severely limited tactical options of the US forces during Operation Desert Storm. Mine neutralization capability is fundamentally important for future and present operations.

## **BACKGROUND**

Many concepts for removing mines from soils have been investigated. These alternatives have met with limited success when mounted on lighter host vehicles. US Forces currently have limited mine clearing capabilities including Track Width Rollers, Track Width Mine Plows, Mine Clearing Line Charge (MICLIC) and MARK 154 (3-shot line charge). The MICLIC and the MARK 154 provide a narrow irregular path and had degraded performance against fuzing currently employed. Full width plows and rakes have been investigated on special purpose vehicles but are limited in their capabilities.

## **GOALS**

It behooves us now to identify technologies that can revolutionize approaches to dealing with the mine problems. We must emphasize those technologies that contribute to the Navy-Marine Corps Mine Warfare Campaign Plan and its thrust to support Operational Maneuver from the Sea and "organic" mine countermeasures.

## **MISSION/CONCEPT OF OPERATIONS**

The draft operational requirements document for Shallow Water Mine

Countermeasures (SWMCM) Mine/Obstacle/Clearance outlines the Navy and Marine Corps mission for both short and long term systems to clandestinely clear obstacles/mines from the amphibious landing areas. Existing mechanical systems have met with limited success. These systems include mechanical mine plows, rollers, line charges and rakes.

For the short term, the capabilities required include a two lane breach 50x150 yards within 1 hour and 20 minutes (14 square ft/sec) and one lane 10x150 yards within 50 minutes (4.5 square ft/sec). It is required that 90% (95% desired) of all obstacles and mines in the designated areas be cleared. Here is where we envision that modified systems may support this short term concept of operations.

## MODIFIED CONSTRUCTION EQUIPMENT

Two US companies (CATERPILLAR & CLAUSEN POWER BLADE) have used innovative ideas to use construction equipment converted to meet military requirements to clear mine/obstacle fields. Examples: (1) D-7G/D-8N dozer with armor and angled rakes are now used by NATO to clear mine fields, (2) 320L Hydraulic Excavator with armor used to extract unexploded ordnance for future disposal, (3) 325L Hydraulic Excavator with extended arm and remote control and thumb is also used to remove unexploded ordnance in ground or from a berm, (4) 963 Track-type loader with armor is utilized for unearthing the unexploded ordnance, (5) Clausen Power Blade mounted on a D-7G/D-8N has been tested three times and been very successful in removing mines/obstacles in both sand and hardpack. It has also cleared wide areas for the LCAC to land once on the beach.

Since I have been involved in design, build and testing of Marine Corps prototypes for the past 12 years, I believe that this is the answer to our short term problems.

Most of you are familiar with the earth moving equipment that Caterpillar builds, but may not be with the Clausen Power Blade of which I was the Senior test engineer on the last mine/obstacle test at Camp Pendleton, Ca. I will explain how this innovative piece of equipment is designed.

The system tested consisted of a single D-8N with Powered Blade System mounted. The D-8N is a tractor modified by the addition of the auxiliary power

unit mounted on the rear of the tractor and by the addition of a powered blade mounted in place of the standard dozer blade. No welding is required on the D-8N tractor. The powered blade system was bolted to the D-8N tractor including the auxiliary power package. This package is mounted in place of the ripper on the rear of the tractor.

The Mine/Obstacle Clearing powered Blade System is made up of the following components/assemblies excluding the host D-8N:

- a. Powered blade assembly.
- b. Auxiliary power unit.
- c. Control subsystem.
- d. Interface installation kit.

1. **Powered Blade Assembly:** The powered blade assembly contains the belt, hydraulic motors, drive sprockets/rollers, and cutting edge. This assembly interfaces with the auxiliary power unit and control subsystem using quick coupling hydraulic connectors. This assembly interfaces with the D-8N dozer C-frame using a drop pin assembly. The original tilt cylinders have not been altered. These cylinders are connected to the powered blade using drop pins.
2. **Auxiliary Power Unit:** The hydraulic power unit is a commercially available diesel engine and hydraulic pump assembly. This unit provides hydraulic power for the motors driving the vertically oriented conveyor belt (the belt replaced the standard dozer blade assembly). The engine is mounted on the rear of the D-8N tractor.
3. **Control Subsystem:** Control of the powered blade assembly is accomplished from a control panel mounted to the right of the operator's seat in the D-8N cab. The powered blade's belt speed is controlled through an infinitely variable speed, reversible hydrostatic drive system.
4. **Interface Installation Kit:** This kit is a collection of the various controls and attachments required to integrate the powered blade system and the D-

8N tractor. The powered blade is attached to the C-frame of the tractor by installing the center pivot pin and two pins. These two pins connect the lower push arms which are part of the powered blade. In addition, the powered blade assembly contains two tilt double acting cylinders. These cylinders are hydraulically attached to the tractor blade control hydraulics.

The Power Blade assembled consists of a partially encased, hydraulically powered, rotating steel belt which is mounted to a D-8N dozer. The rotating belt results in a side sweeping action which casts aside accumulated spoil (plowed up dirt/soil, sand, and obstacles). At the base of the Power Blade is an angled steel blade (approximately 18 feet wide) with steel tines attached to the bottom at 18 inch intervals.

During my last test, the Power Blade was attached, by support arms, to a Caterpillar D-8N dozer at an approximate blade angle of 30 degrees and angled right at 26.5 degrees. A control panel, located within the D-8N's cab, allowed the operator to control the Power Blade's vertical height, pitch and roll, as well as belt speed and belt direction (clockwise or counterclockwise). The Power Blade's side sweeping belt is powered by five hydraulic motors. An Auxiliary Power Unit (APU) is used to supply hydraulic pressure and is mounted on support beams which extend back from the rear of the D-8N.

**RESULTS:** The Power Blade made seventeen runs both in sand and hardpack utilizing both mines only and a combination of mines and obstacles with a high success rate. The Power Blade cleared **93%** of all mines encountered in hardpack and **99.6%** of all mines in wide area clearance (100 by 100).

**CONCLUSION:** By using NDI items such as the Clausen Power Blade and Caterpillar equipment, we eliminate the long R&D process and can modify the equipment rapidly to comply with military needs.

# **Application of Seismic Vibration Concepts for Rapid Mine Clearance and Detection**

**Geoffrey C. Davis,**

President, Capstone, Inc.

**Steve Ballinger**

Executive Vice President, Mertz, Inc.

## **Statement of Problem**

Current methods of land mine detection and clearance require time consuming, high risk operations to detect, map, and clear land mine hazards. In older fields, mines can shift or settle, increasing the difficulty in detection and clearance. Mines pose both a short term tactical problem and long term humanitarian problem in many areas of the world.

The purpose of this paper is to introduce a new application of a proven technology that will minimize the negative tactical and humanitarian effects of land mines. Passing resolutions against the use of land mines may be less effective in the long run than simply fielding technology that limits, minimizes, or eliminates their usefulness in military operations.

*Some questions to ponder before we begin...*

**What value could you place on a device that could help save thousands of soldier's and civilian's lives each year that might otherwise have been lost to inadvertent mine detonations?**

**How much good will could be purchased in friendly nations by quickly clearing areas infested with mines without causing excessive collateral damage?**

**What would you say if you could provide your tactical units with a low cost, low risk, safe, rapid means of mine detection and clearance?**

**What if that device were able to provide your commanders with an additional 30 minutes of tactical surprise in a breaching operation and avoided the need to channel your vehicles into narrow lanes to pass through a hazard area?**

**Would there be utility in fielding a proven industrial technology that is currently in use in every area of the world?**

Does this sound too good to be true?

Such technology exists today and may be readily adapted to land mine detonation, detection, and clearance. The application of this proprietary technology may be a key link in providing seamless transition through mined areas. The concept would support wider lane clearance, deliberate breaching operations, and post-operation area clearance.



## **Current Situation**

Many world governments have expressed concern over the problems associated with the use of land mines. Over 100 million anti-personnel mines litter the globe and cause an estimated 26,000 casualties every year. The great majority of these mine casualties are civilians.

The tactical issues associated with land mines are also significant. Mine hazards put units at risk by harassing, channeling, delaying, or exposing friendly troops to great dangers. Random mine ambushes are a source of irritation and can damage the momentum of an operation. Furthermore, tactical surprise can be lost because of the time needed to clear safe lanes for breaching operations. The humanitarian impact is staggering. Long after the guns are silent, mines can prevent routine movement and normal land use over large sections of a region.

Indeed, teams of government and private industry professionals are trying to develop new tools to combat this problem. These range from adapting older mine clearing tools that date to the Second World War to applications of modern sensing technologies. The traditional methods of clearing an area could require the use of devices like mine detectors, vehicle driven rollers, line charges, and luck. Mine detection and clearance normally exposes soldiers to great risk.

Humanitarian issues pose an even greater problem because civilians and children do not have adequate knowledge to deal with the hazards imposed on their home areas. In order to minimize risk and apply new tools, modern teams are seeking to provide clearing devices that improve safety and preserve operational flexibility. However, even the new technology applications have experienced limited success.

An article in the April 1996 issue of *Mechanical Engineering* discusses this further. In "Searching for Land Mines", author Steven Ashley stated that the U.S. military is sponsoring several new and expensive methods of mine detection and clearance<sup>2</sup>. The current devices in development generally require one or more of several conditions to perform effectively. For example, various technology tools may require a mix of recognizable mine placement patterns; homogeneous (clean) soil without rocks, roots, or shell casings; little or no vegetation; high daytime thermal gradients; and/or favorable soil resistivity.

These types of conditions are rarely found together in threat environments. Patterns are less frequent in unconventional warfare environments. Indeed, even conventional patterns can break up over time due to soil shifting, device settling, or water run-off. Homogeneous soil typing is restricted. In fact, many ideal hazard areas and choke points have rocks on or near the surface. With the exception of the Middle East, vegetation appears to be prevalent in the world's mine hazard regions. Moreover, the thermal gradients may vary by region and weather patterns. Finally, soil resistivity varies from region to region.

In the end, the difficulty in achieving the right mix of ideal conditions could make it difficult or more hazardous for a mine clearing operation to be conducted for either tactical or humanitarian purposes. Some groups are employing more "muscular" approaches by upgrading mine plows and rollers. Mine detection is confirmed by exploding the device upon contact. Although such equipment will destroy mines, the resulting explosion may also disable the host vehicle, cause collateral damage, block the clearing lane, and cause serious injuries. Also, ground damage from plows and line charges can be extensive.

Mertz suggests a rugged and cost effective hydraulic solution which applies seismic principles.

## **A New-Old Approach**

For nearly a generation, the petroleum industry has used seismic vibration as a means of supporting oil exploration. Several vibrator trucks will be placed in sequence and induce seismic waves into the ground simultaneously. The data is recorded by geophones and translated into a graphical representation of the subsurface strata similar to a sonogram. In turn, geophysicists determine the likelihood of petroleum deposits in that area.

Mertz, Inc. is the largest producer of seismic vibrator vehicles for the petroleum industry in the world. The company has developed and patented many types of vibration hardware and vehicle components. Currently, they have vehicles in service on every continent and in every climate region on Earth except Antarctica. They have been designed to work in climates ranging from the frozen North Slope of Alaska to the sands of the Sahara, and on all vehicle accessible terrain types. Mertz provides operational, training, and logistical support in more than 30 nations around the world.

In 1954, Mertz manufactured an eccentric mass (or "swing weight") vibrator for Conoco. A prototype servo-hydraulic vibrator was tested in 1957 and placed in service for normal operations in 1959. In the 1960's, vibrators were mounted on the rear of trucks, but by the mid-1960's, the design was altered by moving the vibrator assembly to approximately the center of the vehicle. This new position put a larger percentage of gross weight on the baseplate to improve earth coupling.

Mertz began fielding the next generation of vibrators in 1969 when they were licensed by Conoco to build the "Model 8" vibrator. The first production units were delivered to Conoco in January 1970, with continuing production for other companies.

Numerous improvements have been made over the years, and Mertz provides numerous vibrator models to choose from. Vibrators are mounted on commercial trucks, all-terrain buggies, and tracked vehicles.

Rather than inventing a new technology, Mertz, Inc. believes that its proprietary technology can be applied to this situation in order to provide an immediate low cost, low risk solution to both the humanitarian and tactical problems associated with land mines. From their headquarters in Ponca City, Oklahoma, they provide worldwide production and logistical support to exploration teams around the world.

Mertz believes their technology may be another tool that can be used in solving the tactical and humanitarian problems associated with land mines.

## Thesis Statement

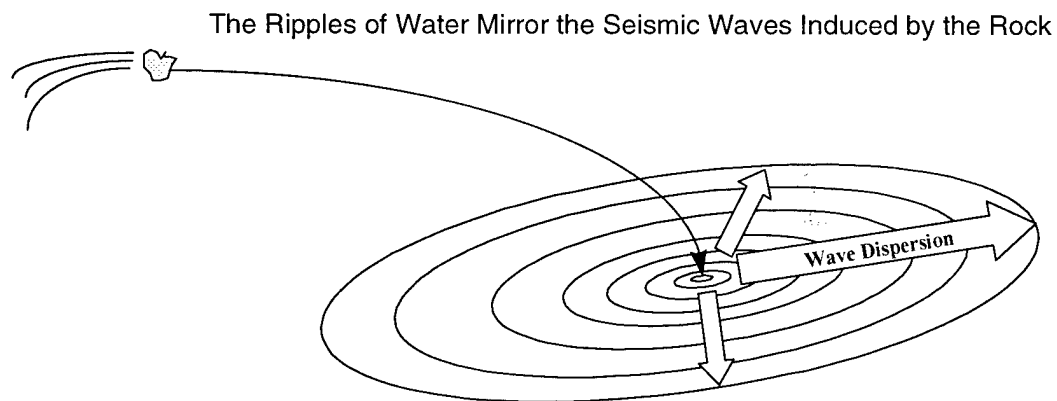
**Powerful seismic vibrations generated by a mobile energy source can detonate and detect land mines with minimal risk to personnel and equipment.**

### The Seismic Vibration Concept

When a person throws a rock into a pool of water, the impact of the rock creates disruption of the water surface and causes the waves generated by the force to move outward from the point of impact in a hemispherical pattern. Depending on the depth, the wave energy can disrupt the bottom surface and stir up debris and soil. Seismic vibration works in basically the same context.

## A Principle Analogy

**...Tossing a Rock into a Lake.**



- >The Surface “Rolls” with a Wave Pattern
- >Loose Objects and Matter on or below the surface are Agitated

© 1996 Capstone, Inc. & Mertz, Inc.

As the soil particles accelerate away from the impact point of the baseplate, the wave pattern creates a Rayleigh Wave or “Ground Roll”. This extends away from the center of impact until the vibration is dissipated or dampened by the soil. On smaller commercial vibrators, a low frequency vibration can liquefy or seriously agitate surface soil outward for about ten feet. A large shear wave vibrator could induce far greater “Ground Roll” and could cause serious soil displacement for 20 to 30 feet out from the point of impact, depending on soil type, retained moisture, and temperature.

Copyright 1996 Capstone, Inc. & Mertz, Inc.

A **seismic vibrator** is a 4-stage electro-hydraulic system which oscillates a large reaction mass in order to generate equal and opposite forces which are transmitted through a supporting structure and baseplate into the earth. The resulting oscillatory force of the baseplate creates seismic waves which radiate in hemispherical wavefronts through the earth. The vibrator simultaneously produces "Ground Roll" which interferes with seismic data.

As seismic waves travel through the earth, they encounter layers of differing density, which have different velocity characteristics, and cause some of the seismic energy to be reflected. Reflected seismic waves travel back to the surface where sensitive transducers called "geophones" convert the ground motion into electric signals proportional to earth particle velocity. Seismic interpreters use these signals to calculate the depth of reflecting surfaces; and produce maps of subsurface layers.

For the purposes of mine detonation and detection there are three wave types that should be defined: Shear Waves, Rayleigh Waves, and Ground Roll.

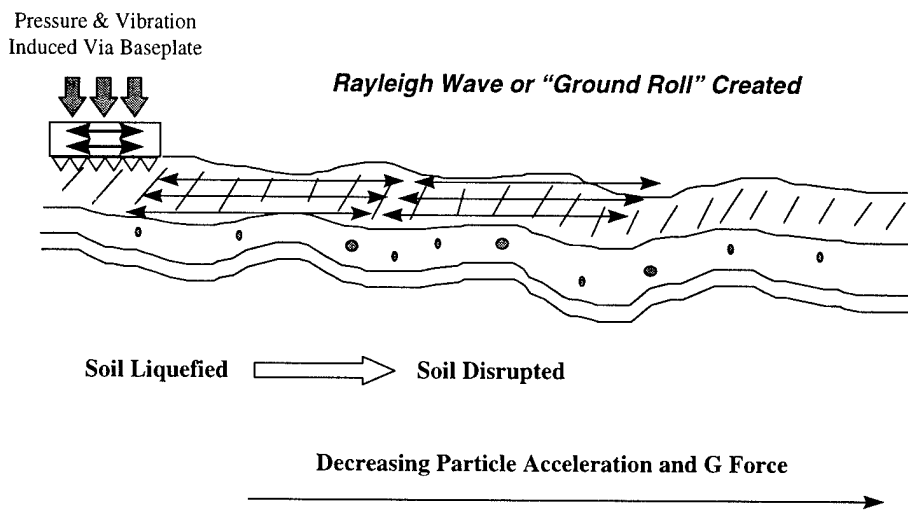
**Shear Wave:** a seismic wave in which particle motion is perpendicular to the direction of propagation. Shear waves propagate radially outward from the source along a hemispherical wave front.

**Rayleigh Wave:** a surface seismic wave in which particle motion near the surface is elliptical and retrograde. Rayleigh waves propagate radially outward from the source along a cylindrical wavefront. A large share of the energy radiated by a seismic source consists of Rayleigh waves.

**Ground Roll:** surface wave ground energy which propagates radially outward from the source along a cylindrical wave front. Rayleigh waves are usually the main source of ground roll.

The "Ground Roll" is a useless "by-product" of the energy source used for petroleum exploration. However, this by-product is the very means of land mine detonation, detection, and clearance. Soil particles below the baseplate are accelerated at a rate which overcomes normal soil cohesion. The soil beneath the baseplate and in the surrounding area is liquefied. There is a ripple effect outward from the baseplate similar to the concentric rings formed by tossing a stone into a pool of water.

## Seismic Vibration Concepts



© 1996 Capstone, Inc. & Mertz, Inc.

In his text, *Vibrations of Soils and Foundations*, F.E. Richhart, Jr., *et. al.* observed that the surface is *liquefied* when a "saturated mass of soil is caused by external forces to suddenly lose its shearing strength and to behave as a fluid....Liquefaction may [also] develop by impacts or repeated loadings applied to loose or cohesionless soils." <sup>3</sup> Further research showed that soil can be liquefied by inducing steady state vibrations. Soil liquefaction occurs in an earthquake. This is seismic vibration on a large scale. Indeed, the use of modern commercial seismic vibration technology generates a localized earthquake in order to generate data. Currently, soil liquefaction is not a part of any mine countermeasures doctrine.

### Facts and Assumptions

The thesis of this paper suggests that the principles applied so successfully in the geophysical disciplines can be applied to the problem of detecting and clearing land mines.

Mertz, Inc. is the largest producer of seismic vibration devices in the world. They have developed and patented many components and concepts in this discipline. These tools are currently used in commercial geophysical applications ranging from petroleum exploration to earthquake research.

This analysis is based on both the foundational physical properties of energy transfer in soils and the current methods of detonating land mines. Moreover, the United States Navy Coastal Systems Station at Panama City, Florida, successfully conducted an informal test in January 1996 that validated the basic concept using a small commercial vibrator to activate the fuses of various explosive devices.

## **Key Facts**

- Seismic Vibration Devices have been in use for a generation.
- Mertz, Inc. currently manufactures the key components for a seismic vibrator that may be applied to a mine clearing vehicle.
- Technology for such a vehicle exists and could be quickly integrated for testing at a relatively low investment.
- The U.S. Navy conducted a successful informal test in January 1996 which demonstrated that a shear wave vibrator could be used to detect and detonate land mines.
- Risk is reduced by removing the need for people to handle devices directly or use manual search tools in most situations.
- Risk is reduced significantly because the vehicle can be remotely controlled, and because the vibration should detonate mines without direct vehicle contact.
- The **Seismic Counter Mine Vehicle** could be integrated with optional equipment to allow unmanned continuous operations for mapping and precise area clearing.
- Current sensing technology could be adapted to allow for remote identification and mapping of unexploded devices.
- Vibration induced detonation would cause less collateral damage than clearing operations conducted with plows and line charges.

## **Key Assumptions**

- **CRITICAL ASSUMPTION:** The Defense community desires a device that will destroy Anti-Personnel Mines and Detect Anti-Tank Mines with a minimum of risk and complexity.
- Mine detection and clearance could be conducted using either a remote controlled vehicle or host vehicles to carry the system.
- The **Seismic Counter Mine Vehicle** would require terrain that is accessible to typical tactical or construction vehicles.
- The **Seismic Counter Mine Vehicle** will be significantly influenced by soil properties.
- The General Design Concept assumes that all components will be integrated with off-the-shelf or easily fabricated sub-assemblies.
- The General Design Concept assumes that the **Seismic Counter Mine Vehicle** would need to move with the tactical units and thus the system would be mounted on a host vehicle or in a self-contained vehicle.
- The device would allow the clearing or breaching of mine hazards to be accomplished in less time with a wider area cleared.

## **Principles In Context**

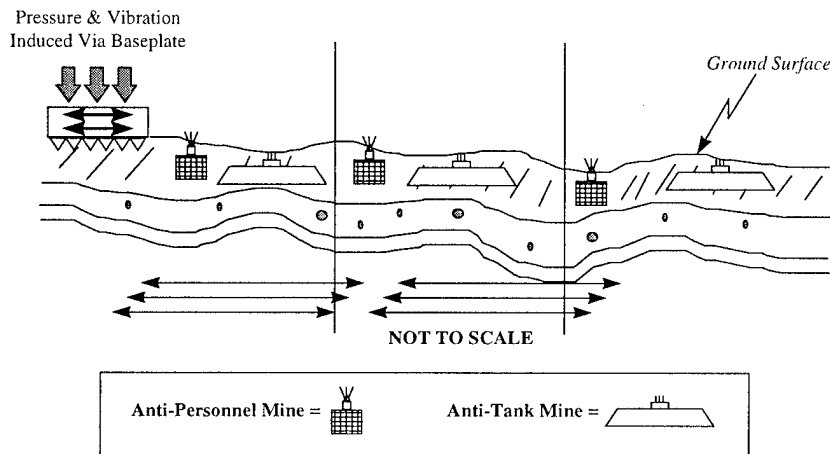
Before discussing any design concepts, it might be helpful to illustrate how the technology works in detecting or clearing a mine hazard. Mine hazards may be known or suspected in an area. If the field has been set for a long period of time, the original patterns may have been disrupted, invalidating any maps. Moreover, traditional mine field clearing or breaching often involves a combination of burning surface vegetation, manual detection, manual marking, rolling, plowing, and planned detonation. The **Seismic Counter Mine Vehicle** would lessen the need for these other tools in many situations.

Mine clearing and detection could be done in a manner similar to current seismic exploration operations. That is, a baseplate would induce horizontal shear wave vibrations into the ground. As previously mentioned, in petroleum exploration, the effects of "Ground Roll" on the immediate soil surface is a "by-product" of the vibration process. In the case of mine clearance and detection, the surface disruption is precisely the desired outcome. For example, a vibrator generating 150,000 pounds of shear wave force would create exceptionally strong "Ground Roll" spreading out horizontally from the device. The following figures illustrate a schematic mine hazard that contains both Anti-Personnel and Anti-Tank mines. The G-Forces near the device would actuate the Anti-Personnel devices.

As an aside, during the informal Navy test in the January 1996, all of the Anti-Personnel Mines were actuated during the static vehicle test. This occurred with no prior envelope analysis.

In the figures below, a schematic baseplate is transmitting vibrations into the ground of hazardous area. In the following scenario, it can be assumed that no mines have been confirmed previously. The vibration pattern could be set to take advantage of the ground resonance frequency for the soil type.

## Mine Proximity

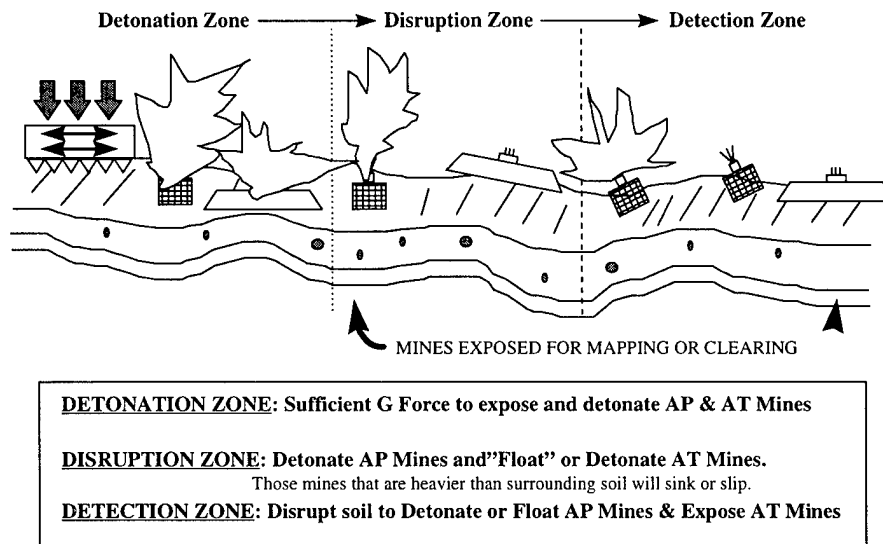


© 1996 Capstone, Inc. & Mertz, Inc.

As vibrations travel outward from the baseplate, the "Ground Roll" will cause the surface to liquefy and ripple. Visualize grasping a bedspread that had toys laid on it. If the bedspread is shaken out in rhythmic pattern, ripples will cycle across the top and bounce or "float" the toys. The analogy would hold true for mine clearance and detection.

The "Ground Roll" would pass through three basic zones: The Detonation Zone, The Disruption Zone, and The Detection Zone.

## Vibration Impact on Land Mines



© 1996 Capstone, Inc. & Mertz, Inc.

The "Ground Roll" will cause the nearby surface soil to liquefy and the G-Force caused by soil particle acceleration will detonate the mines in the **Detonation Zone**. Spontaneous detonation will occur in this zone. All passive fused Anti-Personnel mines would be exploded. Anti-Tank mines could be detonated, depending on the mine type and the G-Force impact. Depending on the soil type, the G-Forces generated by the "Ground Roll" could be magnified and have a hammer-like effect on the devices. Worst case, the Anti-Tank mines would be floated, slipped, or disabled by the excessive "Ground Roll" forces. Any Anti-Tank mines not destroyed could be marked and destroyed by other means.

The "Ground Roll" will begin to degrade as they pass into the **Disruption Zone**. In this Zone, Anti-Personnel Mines would be detonated and the Anti-Tank mines would be floated to the soil surface. If a mine happened to survive the G-Force impact and had a weight and density greater than the surrounding soil, it could sink deeper below the surface. In addition, anti-tamper devices would be set-off and the surface soil would be disrupted around the locations of deep mines. Either way, Anti-Tank mines could be detected and marked. Spontaneous detonation is less probable in this zone.

Before complete dissipation, the "Ground Roll" will pass through the **Detection Zone**. In this zone, Anti-Personnel Mines may be detonated or exposed for marking and clearance. Anti-Tank mines should have a signature of agitated soil above their locations. The Detection Zone is the outer ring of zones around the **Seismic Counter Mine Vehicle**. Spontaneous detonation would probably be limited to those Anti-Personnel devices that are set off by low G-Forces or that are at the inner edge of the zone.



## **General Design Concept**

The General Design Concept for the **Seismic Counter Mine Vehicle (SCMV)** would apply a concept similar to that of the compacting “sheep’s foot” rollers used in the construction industry. Typical vibrators are stationary while vibrating. That is, forces are induced through a stationary, flat baseplate while the vehicle is stopped. In order to keep up with ground vehicles and allow wider “Ground Roll” dispersion, the vibrator and baseplate would be integrated in a roller.

Older generation vibrators originally utilized surface rollers. However, they were not as precise for conveying consistent forces into the earth. In one sense, Mertz would turn back the clock with outward design and incorporate it’s latest vibration technologies into the roller. There is no need for precise force measurement below the surface because mine clearing is only concerned with the first one to two feet of strata.

The **SCMV** could be a kit that was attached to a heavy combat vehicle or be manufactured as a stand alone remote controlled vehicle. The **SCMV** should be able to utilize off-the-shelf technologies. This would include all fabricated parts, drive train, power train, high power variable frequency vibration systems, control units, and sensors.

The **SCMV** could be integrated with a series of sensors to detect mines, suspicious objects, and soil disturbance. In addition, the **SCMV** could be integrated with magnetic Anti-Tank mine arming devices like some of the Israel Aircraft Industries seismo-magnetic mine clearing components that incorporate the electromagnetic signature of large combat vehicles<sup>4</sup>. An alternative approach could to mount a simpler magnetic coil on the device.

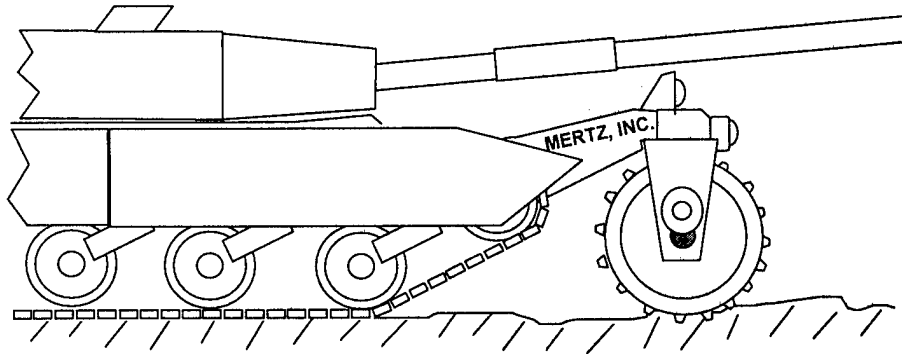
Lets look at two conceptual adaptations of the shear wave vibrator to this mission:

### **Test Design Concept 1**

#### ***Combat Vehicle Attachment***

The first way to achieve the integration of this technology is to attach the Seismic Counter Mine device to a heavy military vehicle. This could be accomplished in a manner similar to conventional ank rollers. However, steering is an issue for this concept. The roller assembly may weigh in excess of 60,000 pounds and generate up to 300,000 pounds of vibratory force. The vehicle pushing this roller may find that it is unable to turn because of the traction associated with coupling the vibrator to the ground. Steering would be accomplished by a center pivot, using the hydraulic system of the roller and linking it to the vehicle’s steering controls. A vehicle adapter kit would be manufactured for the system. The diagram below shows the Seismic Counter Mine device attached to a schematic of an M1 Abrams tank.

## Combat Vehicle Attachment



© 1996 Capstone, Inc. & Mertz, Inc.

Such a design would have the advantage of providing a powerful mine clearing tool to the tactical units themselves. However, shear wave vibrational force would have to be limited so that the host vehicle could control the device. In addition, the vehicle crew would be exposed to the hazards of the mine field. Also, there is the question of utility. Would the host vehicle be adapted to use sensory equipment? Indeed, would the value of having the device on the tank or Combat Engineered Vehicle (CEV) offset the limits in mobility (i.e., high speed turns and dash speed) that would be imposed? Next, the cost of host vehicle system modifications might outweigh the value of the end device. Finally, the high G-Forces and resonant frequency vibrations generated by the system may cause difficulties for maintaining standard vehicles.

Additional study would be necessary to evaluate the utility of adapting the Seismic Counter Mine device to a current combat vehicle.

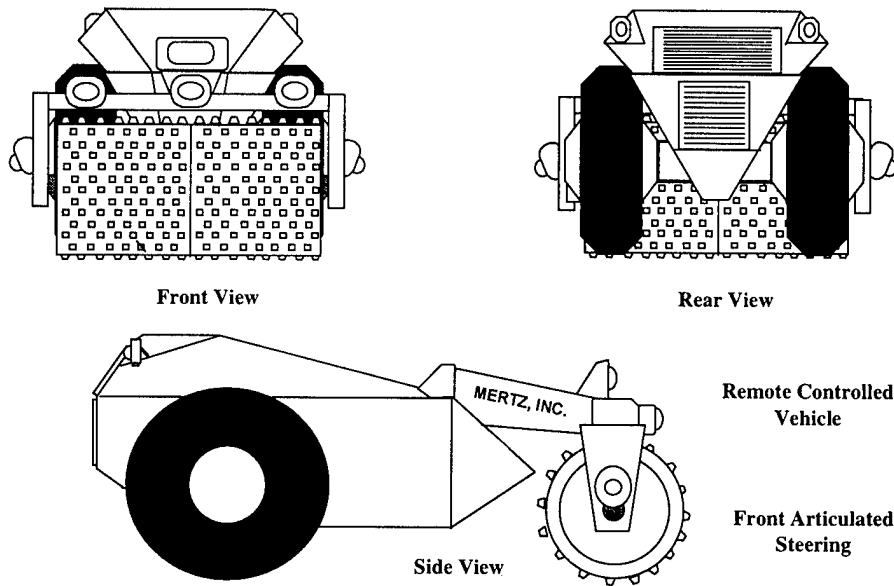
An alternative to adapting a kit to an existing vehicle limited by a different design criteria would be to develop a system for the express purpose of seismic vibration for mine clearing and detection.

### Test Design Concept 2

#### *Remote Control Seismic Counter Mine Vehicle*

The second design concept is based on developing a militarized version of a **SCMV** similar to the products now produced by Mertz. This would incorporate an articulated vehicle frame and powerplant, along with a high performance seismic vibrator. The figure below illustrates how a militarized version of a Mertz Vibrator might look.

## Mertz Seismic Mine Clearance Vehicle (SCMV)



© 1996 Capstone, Inc. & Mertz, Inc.

This **SCMV** could be designed to protect against close proximity mine detonation. The hull would be “V” shaped in order to disperse explosive force away from the device. The **SCMV** would need some degree of ballistic protection around the drive train, sensors, control units, and hydraulic assemblies. The vehicle will be hardened and the roller arm that attaches to the main body of the vehicle will have a hinged shock absorption mechanism to absorb and dampen blast from vehicle mines.

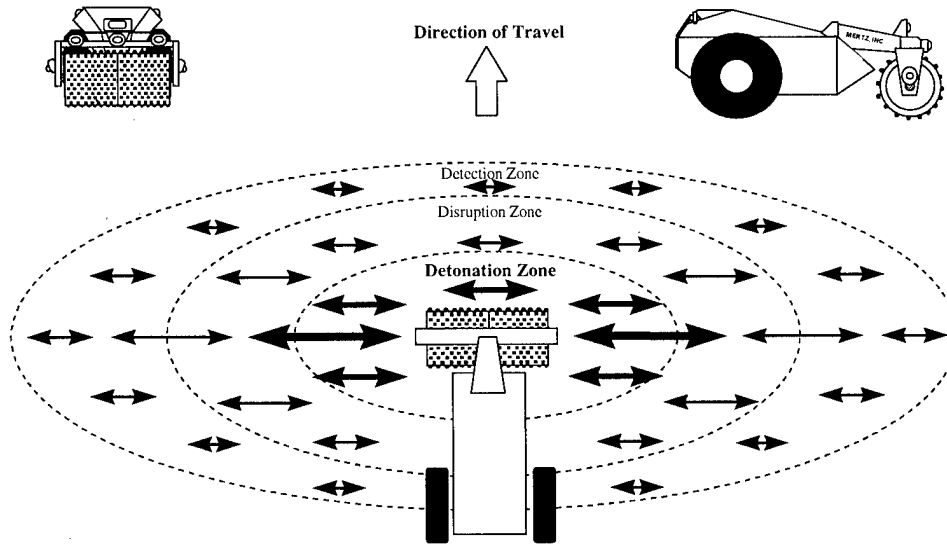
In order to minimize risk, this system could be unmanned and controlled from a remote location. It could be controlled from another vehicle. In fact, depending on the tactical situation, the vehicle could be programmed with a Global Positioning System (GPS) to provide pre-specified continuous unmanned operations over a specific set of grid coordinates. Of course, the remote control **SCMV** could be programmed to alert the controller if a given hazard array is discovered. Such tools would provide greater flexibility for the unit or organization that employed a group of remote control the **SCMV**.

Because this technology may never been utilized in land mine detection and clearance operations, a series of tests may be performed in order to smoothly adapt the concepts of seismic vibration to this realm. The encouraging thing is that although the application is new, the technology is rugged and proven in many regions and terrain types.

The **Seismic Counter Mine Vehicle** would generate horizontal shear waves. The pattern of dispersion would send waves out in a elliptical pattern extending further to the sides of the roller than fore and aft. The area directly to the front of the roller would have the least warning and protection. This could be off-set by a number of means.

First, the system would probably work best in tandem with another device so that their patterns overlap. Next, the vehicles would clear wide lanes by working in a lazy "S" pattern or some other pattern that took advantage of the powerful horizontal vibrations. Third, the devices would operate at slower speeds when they were proceeding directly to the front because of the increased risk and less warning space. Finally, the roller could have a sensor array on the front to assist in detecting threats and stopping or redirecting the vehicle if there is danger. The next illustration depicts the "Ground Roll" fan and the Detonation, Disruption, and Detection Zones.

## Mertz Horizontal Shear Wave Pattern



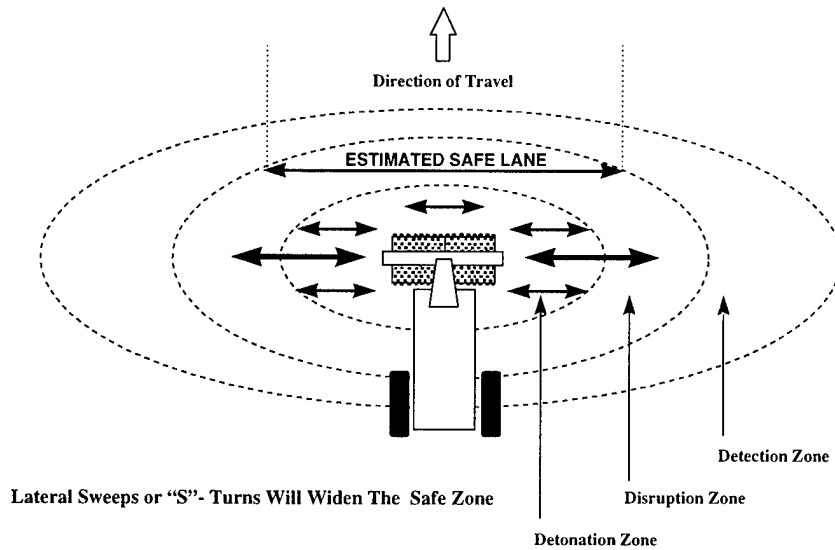
© 1996 Capstone, Inc. & Mertz, Inc.

There are other benefits of the wide fan generated by the **SCMV**. One of the most dangerous operations for a military unit is breaching an enemy defense. The current doctrine calls for a mix of tools that include roller tanks, line charges and ordinance specialist. In the end, the initial breach is often a series of narrow lanes that channel vehicles, slow unit movement, and increase vulnerability. The window of tactical surprise is often narrow. Historically, units have suffered great casualties in attempting to breach mine fields.

The assaulting forces could employ the unmanned **SCMV** to open wide lanes in the area of the Axis of Advance. The vibrators could allow commanders to conserve specialized Combat Engineer units for more specific missions. Also, the employment pattern for the **SCMV** would allow the breaching team to open a series of lanes, or a "safe mobility zone" much wider than current standards may allow. For example, a team of two **Seismic Counter Mine Vehicles** would probably be able open a breach sixty meters (60m) wide and two hundred meters (200m) long in less than ten minutes without exposing soldiers to direct hostile fire. Such a scenario could be proven in further field testing. The next illustration gives a rough idea of the lane width that could be cleared by a vibrator. The width of the lane is a factor of the clearing pattern, the roller force, and the shear wave frequency.

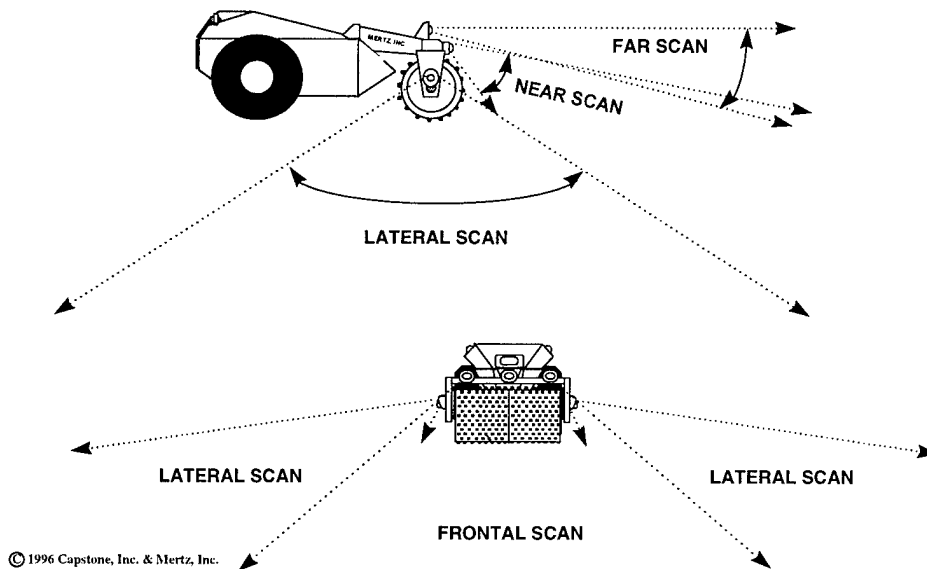
Copyright 1996 Capstone, Inc. & Mertz, Inc.

## Breaching Lane Clearance



Another valuable tool for the **SCMV** would be the integration of day and night video imaging cameras and some form of magnetic, sonic, or thermal sensing equipment. All of these should utilize a down-link capability to share information with operational leaders and planners, far removed from the immediate tactical zone. The technology could be another piece of the integrated battlefield, providing useful information to commanders and their staffs. The figure below illustrates the wide sweep of a sensor array for this system.

## Remote Control Mine Detection Sensors



Smaller **Seismic Counter Mine Vehicles** could provide great value to tactical units, while dedicated vehicles like that of Design Concept 2 could be controlled by the Combat Engineer resources supporting a given mission.

### **General Advantages & Benefits**

#### **Technical**

The use of the **SCMV** for mine detection and clearance could revolutionize the doctrines of mine countermeasures. In the zones surrounding the **SCMV** path, all mines should be either spontaneously detonated or floated to the surface. The vibrations should expose both metallic and non-metallic devices. Large areas could be rapidly marked, mapped, and cleared without the risk of direct contact with the mines. Moreover, the unmanned **SCMV** could be low in cost and easily repairable unless it was destroyed by hostile fire.

A seismic mine clearing vehicle would employ current technologies. The Mertz equipment is currently deployed worldwide and has been proven in all types of circumstances, except combat. The technology is available without extensive research and development.

#### **Tactical**

The **SCMV** could provide a new degree of flexibility to battlefield leaders. This equipment could greatly reduce risk of damage to vehicles, traffic jams in breaching lanes, and the casualties associated with such operations. Wide lanes could be cleared for various tactical needs. Also, the **SCMV** could move with the heavy combat vehicles of the supported units. Although it may not have the dash speed of an Abrams tank, the **SCMV** may be able to keep pace with methodical clearing and bounding overwatch movements.

Also, the devices could be used to map and clear known hazards in less hostile circumstances. There is also a secondary application of this vehicle. The shear wave vibrator roller could be used to provide expedient soil compaction for road repair and assault strip construction. In the end, the greatest tactical advantages are that the system buys time for the commander while reducing the risk of exposure to hostile fire.

The system would provide an excellent means of post-operation area clearance. For example, the vehicle could clear specified tracks to provide safe areas for combat support and service support organizations. Rear area routes and road networks could be cleared quickly by running the device over the road or parallel to the road. Once the critical tactical areas and routes were cleared could be diverted to humanitarian operations.

#### **Humanitarian**

The **SCMV** could serve humanitarian needs by clearing known threat areas and assisting organizations in mapping or locating hazards. This device provides a means of hands off, wide area clearing that could help in rebuilding civil infrastructures after a conflict. In addition, it could quickly return large plots of land to productive uses. The **SCMV** could be a symbol of national good will by helping nations be free of the millions of mines that deny access to productive lands around the world.

## **General Constraints & Limits**

### **Technical**

The use of seismic vibration technology would not completely eliminate the need for skilled ordnance disposal teams or other types of mine clearing equipment. The effectiveness of the equipment in a particular area will be influenced by soil conditions which will affect energy transfer and the ability to liquefy soil. In addition, specialized Anti-Tank mines may not be destroyed. However, based on our understanding, they could be floated for later destruction.

### **Tactical**

The **SCMV** is limited in mobility. The large roller could damage road surfaces. It is likely that the vehicle would need to be carried to the operational area by trailer.

### **Humanitarian**

The vehicle will not be able to detonate devices that are in inaccessible areas. Also, the teams will still require skilled emergency ordnance demolition specialists to remove or destroy devices uncovered, but not destroyed by the **SCMV**.

### **Prototype Development Recommendations**

The prototype options point to either an attachment to an existing combat vehicle or a stand alone shear wave **Seismic Counter Mine Vehicle**. Because both devices would use the same type of roller and vibrator assembly, there might be wisdom in developing both types. First, a smaller kit could be used for localized tactical threats, while the stand alone **SCMV** could be retained for more focused missions. The development process would benefit from the lessons learned in developing the attachment kit and the separate vehicle.

Because the technology is proven, it would be easy to begin the development of a prototype model **SCMV** now. However, there are a number of experiments and tests that would be critical to developing the **SCMV** that would add immediate value to the military and humanitarian groups.

### **Critical Development Experiments and Tests**

The following tests, calculations, or evaluations would be useful to the development effort. These could be quickly performed based on the availability of information from the appropriate directorates.

#### **I. Calculate the optimal vibration actuation envelopes from the known families of mines.**

This would provide valuable data in designing a precise performance standard for the vibrator.

#### **II. Determine the surface wave radiation patterns for the device.**

This data can be collected with a shear wave vibrator, geophones, and a recording device. The wave radiation pattern will help adjust the performance envelope for the **SCMV**. Another aspect of this step would be determining the soil liquefaction criteria for key geographic regions. This will provide performance "boundary stones" for modeling the detonation and detection standards. It could assess soil liquefaction criteria by type, temperature, moisture, and cohesiveness.

### **III. Determine the prototype specification.**

This would define the most powerful device which could be produced and function within the current military vehicle operational constraints. For example the theoretical power is unbounded. Yet a point will be reached where the size of the device and energy output would be impractical for both military and humanitarian missions. Consideration would be given to production, transportation, and maintenance constraints.

### **IV. Conduct structured detonation and detection tests with current production vibrators.**

This test would provide detailed data regarding forces required to detonate various devices and fusing mechanisms.

### **V. Conduct detonation tests for trip wire devices.**

This would allow data to be gathered on the vibration impact on wire triggers and pins from various angles to assess limitations.

### **VI. Develop the prototype roller vibrator device and conduct tests to validate performance expectations.**

The prototype roller would be used to validate the detonation, detection, and disruption zones of the system. This should include tests with both inert and live devices in order to assess the impact of blast damage and force on the performance envelop.

### **VII. Develop a mobile prototype vehicle to apply the lessons gained from the earlier tests.**

This step could begin simultaneously with the development of the prototype roller. Based on the results of this test program, a production design could be finalized and the first vehicle fielded.

Assuming that the performance standards were met, the team could then freeze the design envelope and translate its findings into a production version to include valid product structures, a material plan, production routings, and logistical support requirements. CURRENTLY MERTZ FIELDS A CUSTOM ENGINEERED SEISMIC VIBRATOR VEHICLE FOR THE PETROLEUM INDUSTRY IN ONLY 150 DAYS FROM CUSTOMER ORDER. Reaction time could be rapid once a design was complete.

### **Summary and Conclusion**

Mertz, Inc. is encouraged by the initial assessment of shear wave vibration technology's ability to defeat land mines. We solicit your support in helping translate this proven technology into a new realm in order to save lives and assist in providing effective countermeasures against mine threats.

The next step in the development process would be to complete the experiments, tests, and calculations discussed above. Once analysis begins, Mertz could have a functional prototype vehicle ready for field testing within a short period of time.



End Notes

- 1- Associated Press Article 11/4/96 "U.N. Mine Ban Proposal"
- 2- "Searching for Land Mines", Steven Ashley, Mechanical Engineering, April 1996
- 3- Vibrations of Soils and Foundations, F.E. Richart, et al p. 172
- 4- See U.S. Patent # 5,125,317, dated 30 June 1992, Israel Aircraft Industries, "Apparatus for Detecting Mines."

All other information is based on direct observation, informed sources, or derived from the Mertz, Inc. Archives and Design Records.

Mertz, Inc. and Capstone, Inc. would like to express their gratefulness for the diligent research and wise insights provided by Mr. Dennis Reust of Ponca City, Oklahoma.

## LCAC AUTONOMOUS ALGORITHMS

Jaime Bunczek  
Coastal Systems Station  
Naval Surface Warfare Center, Panama City, FL

### ABSTRACT

The Explosive Neutralization Advanced Technology Demonstration (ENATD) Program is a U.S. Navy program instituted to demonstrate the technology need to explosively neutralize anti-invasion and anti-tank mines in the surf zone and beach zone to support USN/USMC far term, in stride maneuver-from-the-sea Mine Countermeasures (MCM) requirements. To accomplish the objectives, the ENATD has developed a fire control system to launch unguided rockets which deploy line charges and surf zone arrays (nets) from the Landing Craft, Air Cushion (LCAC). The ENATD fire control concept relies on unguided mine clearing munitions launched from an unstabilized platform; therefore, LCAC motion is critical to the accuracy of the fire control system. A test series was performed in February 1994 to determine LCAC motions during low-speed repositioning and stationkeeping maneuvers as a function of operator and environmental input. This test series measured the motions of the LCAC in six degrees of freedom, the positions of the operator's controls, wind speed, and wave height. Using this data, the responses of the LCAC to operator and environmental inputs were empirically modeled to enable fire control algorithm development and evaluation.

Since repositioning and reorienting the craft are critical to generating ballistic solutions for an unguided munition launched from an unstabilized platform, autonomous control algorithms were developed and implemented in the vehicle response model for evaluation. The autonomous control algorithms consist of multiple-input, single-output, nested proportional derivative (PD) rate controllers. These controllers generate the operator control signals to control the three degrees of freedom in the horizontal plane (longitudinal position, lateral position, and craft heading) and are implemented in software. The control algorithms, which calculate the craft operator inputs directly under computer control, not only reduce the time required to reposition the craft but also reduce the operator's workload during repositioning and stationkeeping. During testing in October and November 1995, autonomous control decreased repositioning and reorienting times by 40 percent compared to an experienced LCAC operator.

Although the autonomous algorithms were primarily developed for stationkeeping and low-speed LCAC repositioning, subsequent tests have demonstrated their ability to maintain course and speed, execute coordinated turns at

speeds up to 40 knots, and traverse predefined lanes. These autonomous control capabilities for the LCAC provide significant benefits for other LCAC mission areas.

### INTRODUCTION

Development of the Landing Craft, Air Cushion (LCAC) Autonomous Craft Controller spawned from the Explosive Neutralization Advanced Technology Demonstration (ENATD) project. The ENATD is a Shallow Water Mine Counter Measures (SWMCM) project sponsored by NAVSEA PMS 407 and employs a fire control system to automatically launch unguided rocket-propelled line charges and net charges from the unstabilized deck of an LCAC. When in Fleet use, these line charges and net charges will detonate to explosively neutralize mines in the surf zone.

The LCAC, Fig. 1, is a high-speed fully amphibious hovercraft capable of carrying a 60-ton payload. Over eighty LCACs are in service for the U.S. Navy. The LCAC's principal characteristics are listed in Table I.

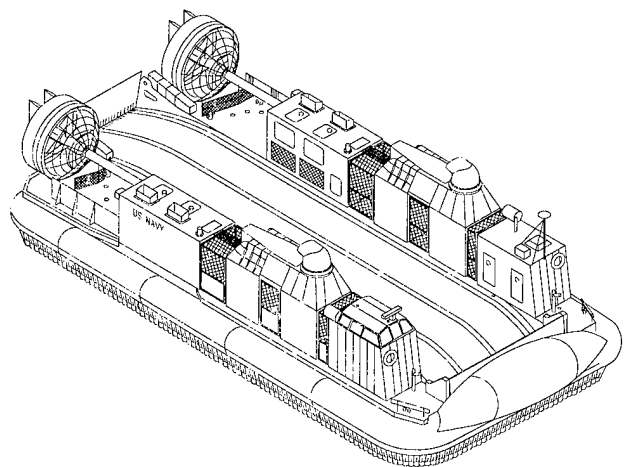


Fig. 1. LCAC

TABLE I.  
LCAC PRINCIPLE CHARACTERISTICS

Descriptive Characteristic	Quantity/Value
Speed, Sea State 2	> 40 knots
Speed, Sea State 3	> 30 knots
Range (nominal)	200 nautical miles
Length (on cushion)	87 feet 11 inches
Beam (on cushion)	47 feet
Height (on cushion land)	23 feet 8 inches
Cargo Area	1,809 square feet
Deck Width	27 feet
Tiedowns	4 rails with tiedown sockets, spacing 12 inch nominal (244 tiedown sockets total)

The LCAC's control system is a fly-by-wire system called the Control Systems Electronics Package (CSEP). The LCAC has three types of control surfaces available for maneuvering: propeller pitch, bow thruster angle, and rudder angle. Fig. 2 shows the operator controlled forces acting in the horizontal plane on the LCAC.

Two rotating bow thrusters on the LCAC provide a constant force whose direction is controlled by the bow thruster yoke and the bow thruster mode switch. During high-speed operation, the bow thruster mode switch is set to forward mode. In forward mode, bow thruster outflow is directed aft to provide forward thrust. During low-speed maneuvers, the bow thruster mode switch is set to reverse mode, which directs the bow thruster nozzles to vent forward, creating reverse thrust. In either mode, the LCAC operator uses the bow thruster yoke to change the angle of the bow thrusters, providing a turning moment for the craft.

The LCAC is equipped with two variable pitch, shrouded propeller assemblies at the stern to provide controllable forward and reverse thrust. Prop pitch, i.e. blade angle, is set by two levers, one for the port propeller and one for the starboard propeller, which can be set independently. The independent setting of port and starboard prop pitch will produce a differential thrust which results in a yaw moment. The forward thrust capability of the props is significantly greater than their reverse thrust. A prop pitch vernier control on the bow thruster yoke allows a small change in both port and starboard prop pitch, without using the levers.

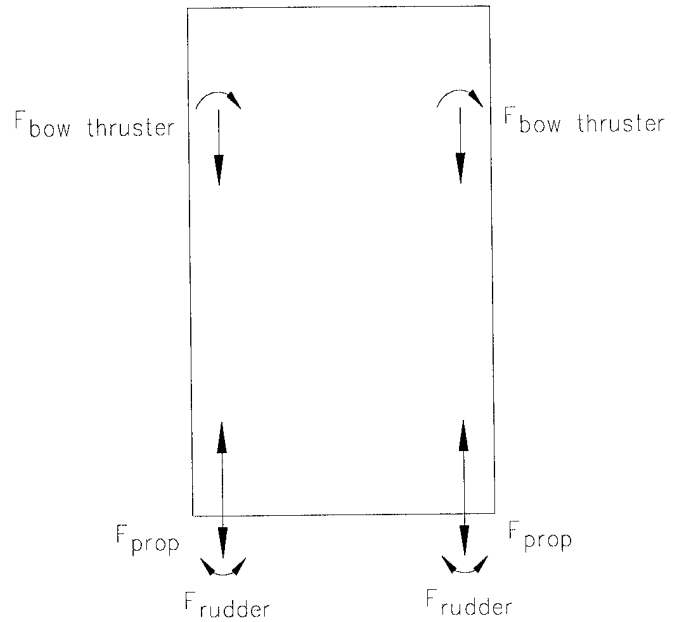


Fig. 2. LCAC Control Forces

Twin rudders mounted behind each propeller provide lateral force and turning moment by redirecting airflow from the propellers. The rudders are effective only when forward prop pitch is applied. A rudder pedal assembly controls the angle of both rudder pairs simultaneously.

With the bow thrusters in reverse mode, the LCAC can be held stationary with a small amount of forward prop pitch, depending on the wind conditions. Even a small forward positive prop pitch produces sufficient airflow over the rudders to maintain their effectiveness. Thus, the craft can be translated sideways by working the props/rudders against the bow thrusters to generate a net side force vector with no corresponding turning moment. This particular maneuver is required for stationkeeping and low speed repositioning and reorientation for deploying mine clearing munitions.

In support of ENATD fire control algorithm development, a test series was performed with LCAC 66 in February 1994. The purpose of this test series was to measure LCAC motions during low speed repositioning and hovering maneuvers as a function of operator and environmental input. Since the ENATD fire control concept consists of unguided mine clearing munitions launched from an unstabilized platform, craft motions are critical to the accuracy of the fire control system. During the testing, motion data in six degrees of freedom, the positions of the operator's controls, wind speed, and wave height were measured. Using this data, the response of the

LCAC to operator and environmental inputs was modeled to a sufficient degree to enable fire control algorithm development and evaluation.

Since repositioning and reorienting the craft are critical to the generation of ballistic solutions for an unguided munition launched from an unstabilized platform, an autonomous control algorithm was derived and implemented in the vehicle response model (LCACSIM) for evaluation. The control algorithm generates the craft operator inputs directly under computer control, relieving the craft operator of the tiresome task of precise craft control necessary for obtaining ballistic solutions in a timely manner.

### AUTONOMOUS CRAFT CONTROLLER DESIGN APPROACH

It was originally intended to use a fuzzy logic controller based design, but after achieving promising results in the software model LCACSIM, Fig. 3, with a controller topology based proportional derivative (PD) control, it was decided to pursue development of PD controllers. Initially, heading

control using only the bow thrusters as the active control surface was examined. By using a PD controller to control heading rate, and making the commanded heading rate a function of the current heading error, a stable response was achieved. This rate selector with nested PD controller topology is shown in Fig. 4.

Since the output of the PD controller is a delta command which is integrated and then limited to the acceptable range of the control surface, this controller topology proved to have a certain degree of adaptability to unestimated outside forces as would be caused by environmental conditions, i.e., wind and wave forces acting on the LCAC. Being satisfied with the performance of this controller topology in controlling heading in the software model, two similar controllers in LCACSIM for the prop pitch and rudder controls were coded. Initially, the bow thruster controller controlled heading, the prop pitch controller controlled longitudinal position, and the rudder controller controlled lateral position. Although the operation of the first two controllers is apparent, the effect of the rudder controller on lateral position is more indirect. The rudders induce a yaw moment, which is not particularly beneficial for

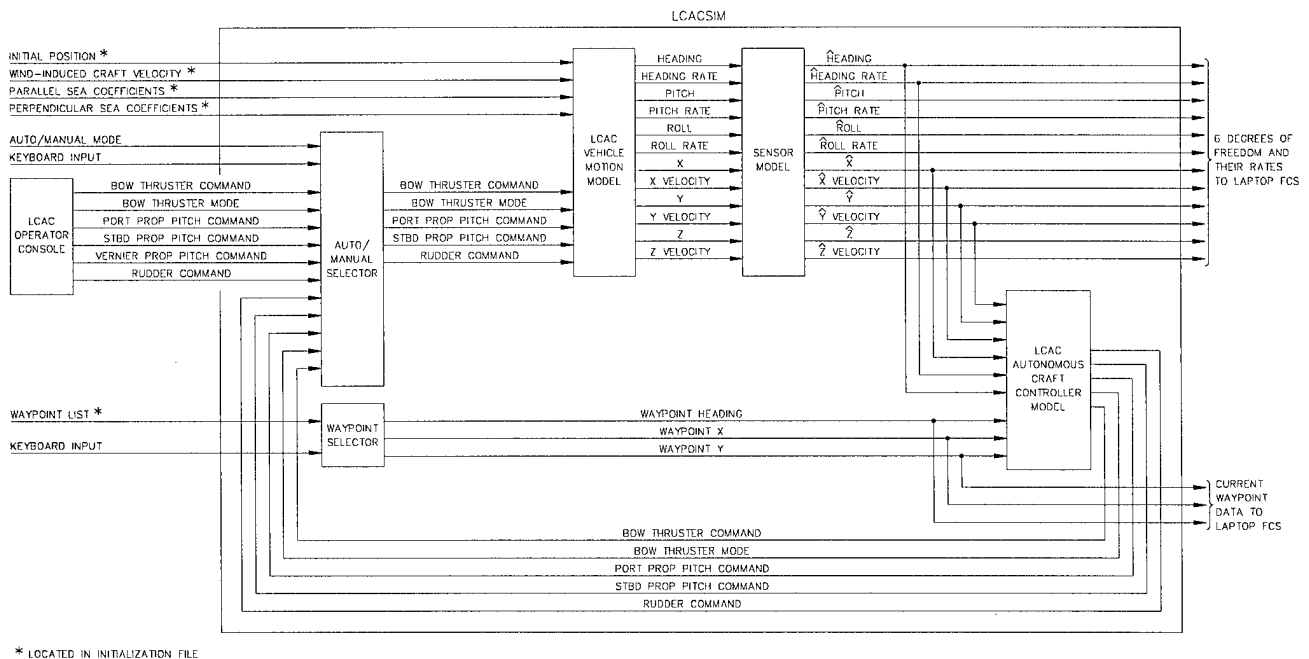


Fig. 3. LCACSIM Block Diagram

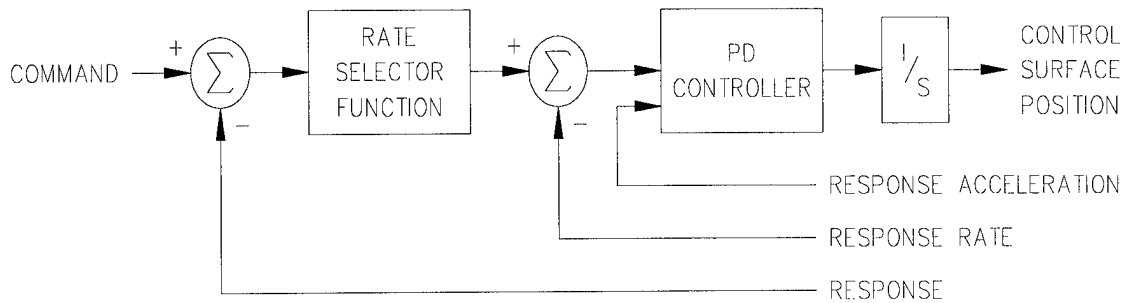


Fig. 4. Rate Selector/PD Controller for a Single Degree of Freedom

controlling lateral position. However, the rudders producing a yaw moment in one direction, cause the bow thruster controller to correct by producing a moment in the opposite direction. The moments cancel and the resultant force vector from the bow thrusters and rudders induces lateral translation.

Since the three horizontal-plane degrees-of-freedom are controlled by the autonomous algorithms, each commanded waypoint consists of three values: heading, longitudinal position, and lateral position. Assigning one controller per degree of freedom yielded a straightforward design. All that was needed was a "command processor" to perform the necessary coordinate transformations on the error values for the position controllers. Navigation data is corrected to the craft center for purposes of symmetry in controller response. Experimentation with this initial controller design showed that it worked well for hovering, but more logic was needed in the "command processor" to ensure satisfactory behavior while transiting between waypoints. As a result, the commanded heading was modified to point directly toward the next waypoint if approaching from a distance. To keep the craft on line while traveling between waypoints, calculation of the lateral error was made dependent on the distance to the commanded waypoint.

It was apparent from early on that while controlling heading and longitudinal position were simple, because of sufficient force from the applicable control surfaces, controlling lateral position (i.e. translation) would be a greater challenge. The original algorithm design required constant positive prop pitch to provide airflow over the rudders to make them effective in controlling lateral position. When the craft is pointed into a stiff headwind, this is not a problem since the combination of bow thrusters in reverse mode and the force from the head wind is sufficient to ensure the prop pitch controller commands positive prop pitch for extended periods of time. A beam wind or tailwind does not offer this benefit, so lateral control suffered. (This was verified during testing aboard LCAC 66 in April 1995.) Therefore, a controller was added to control differential prop pitch.

Since differential prop pitch is another method of generating a yaw moment, this controller was assigned to supplement the rudder controller and give more force for lateral translation. It was successful in both the model and the actual craft, but the individual PD controller coefficients sometimes needed to be adjusted for the algorithms to perform satisfactorily in a variety of wind conditions. It was impractical to "tweak" the controller coefficients to adjust to nominal wind conditions, but the algorithms were performing well enough to not warrant any major restructuring. Some logic to reverse the direction of the rudders for negative commanded prop pitch was included, although this had a minor effect.

In addition to demonstrating stationkeeping and short distance repositioning, this algorithm design was also demonstrated to be capable of lanekeeping. During the Concept of Employment (COE) test for SWMCM systems, the LCAC successfully traversed approximately 1.5 miles between two waypoints while not varying more than several meters from the lane center line. Data for this run is presented in Fig. 5. The speed for this maneuver was 10 knots, but in subsequent tests similar runs were made at 20 and 30 knots. The lane traversal runs were not given a high priority since the focus at that time was stationkeeping.

The biggest advance in algorithm structure and performance occurred during the ENATD Airgun Fire Control System Test. One of the objectives of the Airgun Test was to produce a comparison of mission times for a manually and autonomously controlled LCAC. The Airgun Test consisted of hovering the LCAC at four preselected launch waypoints and allowing the ENATD prototype fire control system to achieve a ballistic solution. Upon achieving a ballistic solution, a projectile was automatically launched by the fire control computer from the LCAC. Launch time, vehicle state, and projectile impact position were recorded for each shot. During preliminary dry fire runs, the autonomous algorithms were slightly slower than the LCAC operator in inducing the LCAC to translate laterally. This led to reassigning two of the controllers to different degrees of freedom. Swapping the duties of the bow thruster

controller and the differential prop pitch controller degraded heading control but improved markedly lateral translation. This indicated that in addition to providing a sizable yaw moment, the bow thrusters generated a considerable lateral force. Rather than optimizing a new set of coefficients for the "swapped" controller topology, the two controllers were combined so that each controlled multiple degrees of freedom. This use of multiple-input, single-output, nested PD rate controllers exhibited superior performance by providing more translational control power in all wind conditions without the traditional "tweaking" of individual PD controller gains. Successful lateral translation has been demonstrated in winds up to 15 knots, which is generally considered to be the operational limit of the LCAC for low-speed maneuvers.

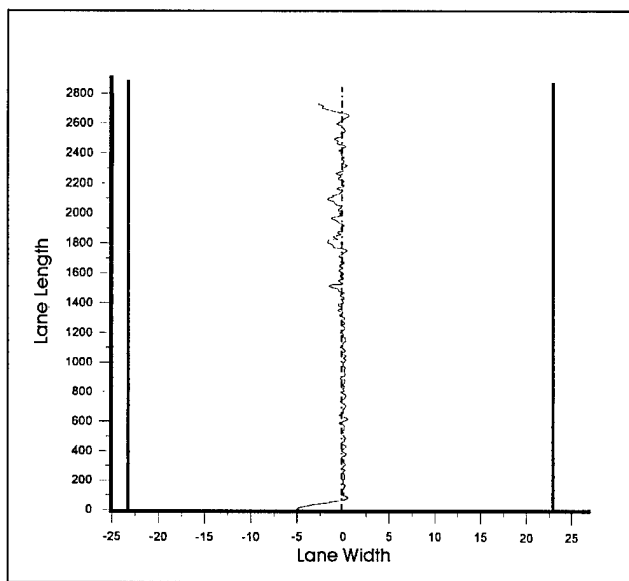
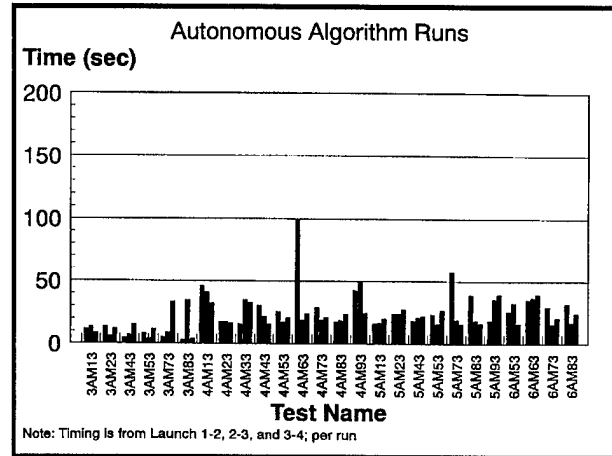


Fig. 5. 1.5-Mile LCAC Traversal

The multiple-input, single-output controller topology reduced mission time by 40 percent compared to the mission times of an experienced LCAC operator. The variation in mission times decreased by a factor of three. Results are shown in Fig. 6 and 7. The same controller topology was also used in Operation Purple Star, CJTFX-96, to hover and reposition an LCAC in while manually launching M68 line charges in the surf zone. The controller demonstrated the capability to perform the mission with significantly less repositioning time compared to an experienced LCAC operator.

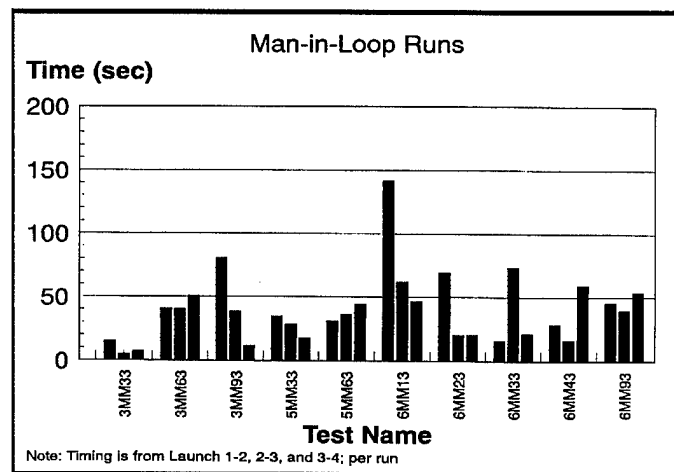
At the conclusion of the Airgun Test, several runs were made with a modified set of autonomous algorithms to assess high-speed control of the LCAC. The command processor waypoint data was replaced with a commanded heading and speed. Lateral position control was zeroed, in effect creating a course and speed autopilot system. This modified set of algorithms

demonstrated the ability of the craft to cruise at high speed (40 knots), while maintaining course. While underway, course changes were input to the control algorithms to evaluate their ability to perform high-speed, coordinated turns. (Limiting the allowable heading rate during a high-speed turn is termed a coordinated turn.)



**AVERAGE TIME = 24.2 sec**  
**STANDARD DEV = 9 sec**

Fig. 6. Man-In-Loop AirGun Test Times



**AVERAGE TIME = 40.4 sec**  
**STANDARD DEV = 26 sec**

Fig. 7. Autonomous Algorithm Test Times

## AUTONOMOUS CRAFT CONTROLLER DESCRIPTION

The block diagrams for autonomous algorithm processing are shown in Fig. 8 through 12. The main algorithm components are the command processor, the bow thruster controller, the prop pitch controller, and the rudder controller. The algorithms are coded in Borland Pascal and executed on an 486 or better personal computer (PC) running under the DOS environment.

The hardware used to implement autonomous control consisted of a Litton LN-100G GPS Inertial Navigation Assembly (GINA) for navigation data, a ruggedized PC to process navigation and attitude data and to calculate craft control inputs, a custom PC/CSEP interface box to relay commands from the computer to the LCAC, a switch and indicator light mounted near the craft operator to select autonomous operation, and a laptop computer to display data on autonomous control mission status. The block diagram for this setup is shown in Fig. 13.

The GINA was used since it is an integral part of the ENATD fire control system. One key issue is noise versus time lag from the navigation sensors. If a lower sample rate is used, more noise and error enter the control loops causing oscillations in the response of the control surfaces. Some of the noise can be filtered out, but at the expense of introducing a time lag in the data which leads to undesirable oscillations in the craft response. Even with the GINA providing the navigation and attitude data to the control algorithms, considerable effort in the area of signal processing was necessary to minimize the noise versus lag problem.

The computer used was a ruggedized pentium computer equipped with a 12 bit, 6 channel digital to analog (D/A) board; an 8 channel analog to digital (A/D) board; a 1553 bus interface board; and a custom buffered serial output (BSO) board. The A/D board contains a programmable onboard clock circuit that generates an interrupt on the PC bus to synchronize timing. The A/D board clock frequency is set to 32 Hz to coincide with the data rate of the LN-100G on the 1553 bus.

The computer interfaces to the LCAC control system via the PC/CSEP interface box, which connects to CSEP channel A and supports two modes of operation: data manual control mode and autonomous control mode. A switch located next to the craft operator enables switching between the modes.

In the autonomous control mode, computer-generated signals for the bow thruster, prop pitch, and rudder commands are transmitted from the computer's D/A board to the appropriate CSEP inputs. To engage the autonomous mode, the craft operator's switch must be in the autonomous mode and the computer's autonomous algorithms must be running. If either condition is not met, the PC/CSEP interface will not allow autonomous control mode to be engaged. An indicator light adjacent to the craft operator's switch indicates whether autonomous control mode has been enabled.

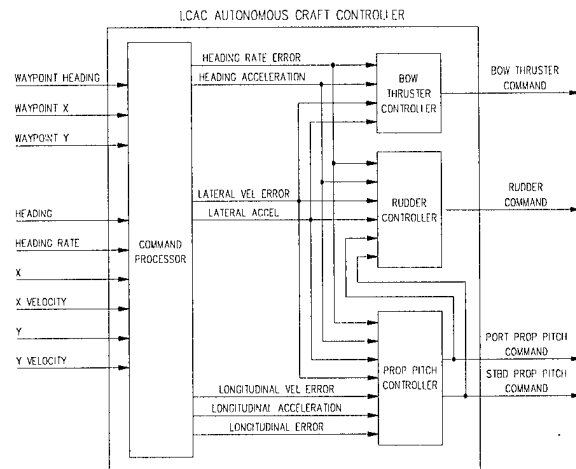


Fig. 8. LCAC Autonomous Craft Controller

## CONCLUSIONS

The autonomous control system developed under the ENATD has been demonstrated to be capable of controlling the LCAC for low speed positioning and stationkeeping in Sea State 2 in support of the far term SWMCM mission. In addition, the system was successful in controlling the craft for lanekeeping and coordinated turns at higher speeds.

Currently the system is implemented as a prototype development testbed, but plans are being developed to field a production kit to the U.S. Navy under the project name SWMCM Kit for Improved Piloting Performance (SKIPPER). PMS 377, the LCAC Program Office, is also interested in incorporating the Autonomous Craft Controller functions aboard the LCAC under the Service Life Extension Program (SLEP), contingent on available funding and schedule considerations.

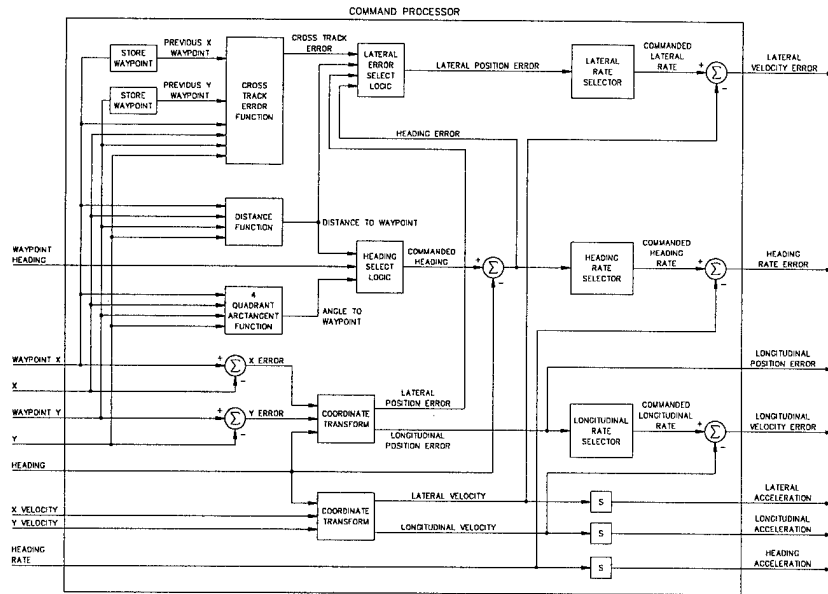


Fig. 9. Command Processor

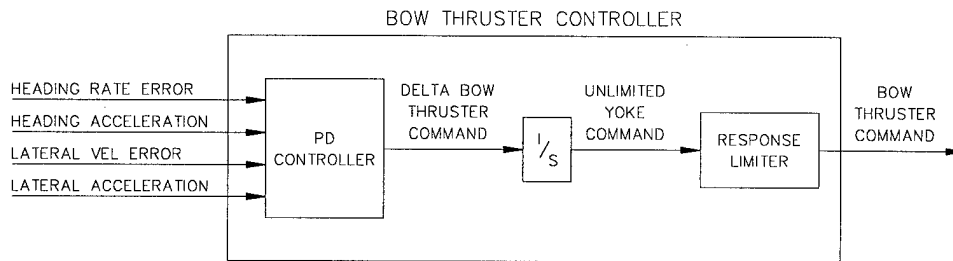


Fig. 10. Bow Thruster Controller

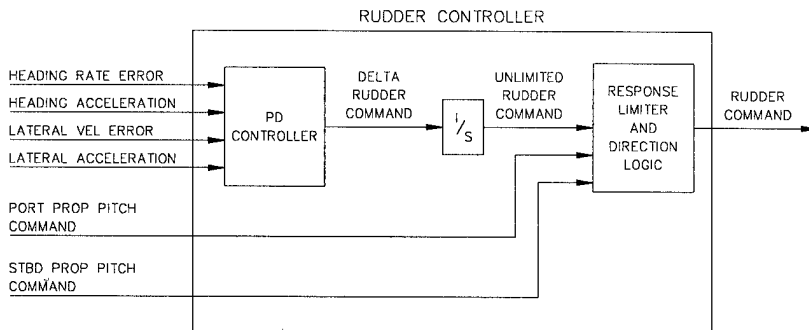


Fig. 11. Rudder Controller



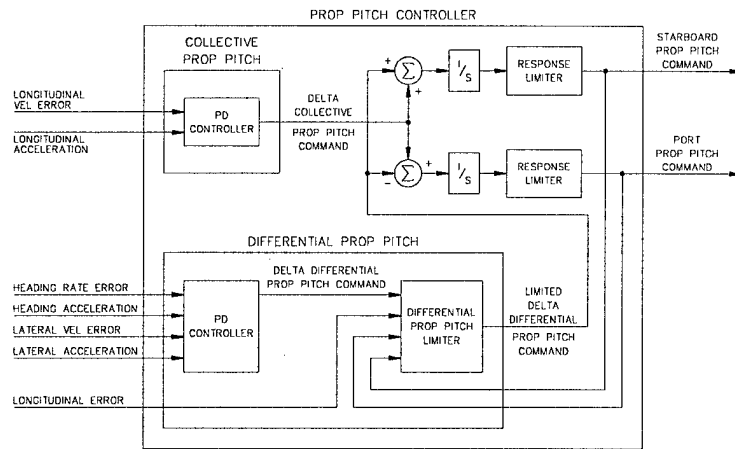


Fig. 12. Prop Pitch Controller

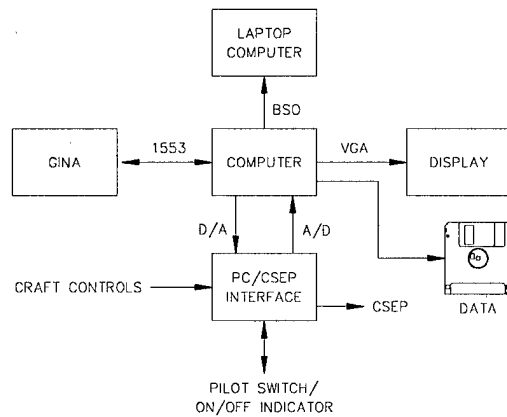


Fig. 13. ACC Hardware

# Rigid Polyurethane Foam Technology for Countermining (Sea) Program

R. L. Woodfin

Exploratory Systems Development Center  
Sandia National Laboratories  
Albuquerque, NM 87185-5800

**Abstract**—This paper presents the results of a recommendation by Sandia National Laboratories that was approved for investigation as a subtask sponsored by the SECDEF Office of Munitions and the joint DOE/DoD Memorandum of Understanding (MOU) for the Countermining Warfare Program. The development of a rigid polyurethane foam (RPF) system that can neutralize mines and beach barriers to allow the safe passage of amphibious landing craft and vehicles was the objective of the subtask. This first phase of the program was a feasibility study that concentrated on laboratory characterization of foam properties supported by field experiments with prefabricated foam blocks to determine the capability of RPF to carry military traffic. The experiments in the field proved the inherent strength of the foam to withstand repeated traffic by tracked and wheeled vehicles, established the flammability characteristics of the material under simulated operational conditions, and extended the understanding of explosive cavity formation in RPF and its response to bullet impact.

## Introduction

Sandia National Laboratories has completed the first phase of exploration in the use of RPF as a passive method to neutralize mined barriers. The RPF material being considered for this application is stored and shipped as a two-part liquid which, after mechanical mixing, expands to 20 to 60 times its original volume depending principally on the strength required in the finished foam. This characteristic allows it to be transported with minimum bulk (ft<sup>3</sup>) in a displacement hull, as in a ship's tanks. The material can be moved by normal pumps, piping, and hoses to the delivery point where it mixes and expands to provide the required volume. RPF materials can be formulated to expand well in water and to solidify in minutes forming a lightweight but durable surface. Under normal conditions of use and/or deployment, this rigid foam has been shown not to produce a significant health or environmental hazard.

This RPF technology is one subtask of the Countermining (Sea) Program sponsored by the MOU. The MOU provided funding to Sandia to explore the potential of RPF as a countermeasure to sea mines and beach barriers. Although this forms a new adaptation of RPF technology, Sandia has many years experience with the use of foams in a variety of applications, including structural/mechanical components for weapons, insulation of high risk transportation systems, and nonlethal applications for security systems. A Technology Coordination Group (TCG) with representatives from PEO Mine Warfare; Naval Coastal Systems

Station; Commander Mine Warfare Command; Office of the Chief of Naval Operations, N85; Naval Surface Warfare Center, Indian Head; USMC Intelligence Activity; and the Office of Naval Research was organized. The Army's Night Vision and Electronic Sensors Directorate (NVESD) and the Logistics Integration Agency, a field operating agency for the Deputy Chief of Staff for Logistics (DA DCSLOG), have been invited within the last month to participate in this TCG as well. The TCG provides direction and technical advice from the Services. If the technical feasibility of using RPF material in this application is proven, the DoD can contract with industry to develop an operational assault system.

The Sandia concept envisions the on-site production and deployment of RPF into a ramp-type shape that would be emplaced over the mined barriers in the assault lanes of an amphibious operation as depicted in Figure 1. The immediate task is to determine if RPF is capable of withstanding the safe passage of amphibious vehicles and affording protection against detonation of mines in an anti-invasion barrier. The task in this first phase of the project was to determine by laboratory, field experiments, and analysis the feasibility of employing foam that would endure the hostile environments of a combat assault. A series of laboratory experiments were conducted in Sandia's chemical laboratory facilities. Prefabricated blocks of varying foam densities were obtained from Allied Signal, Kansas City, MO. Field experiments were performed between November 1995 and February 1996 at the Energetic Materials Research and Testing Center (EMRTC) of the New Mexico Institute of Mining and Technology, Socorro, NM.

Experimental work to test the suitability of using RPF in combat situations was divided into five categories: Chemical Laboratory work to verify basic foam characteristics; Operational Experiments to investigate the ability to withstand simulated battlefield conditions; Delivery Technique Exploration to identify engineering direction and problems; Analytical work to provide a firm basis for experimentation; and Demonstrations of the concept to the military users. Delivery techniques are under investigation at the time of this presentation and will be reported later in FY97.

The laboratory work at Sandia involved the testing of a variety of commercially available foams for their ability to rise and

## Suitability Experiments

produce good quality, hard foam in water. Those that proved best were further tested to determine their mechanical strength under different operational conditions. Experiments to determine mechanical strength vs foam density, foam temperature, and time were conducted. Another series of lab experiments investigated the effects of varying component temperature, water temperature, time to set up, and mix precision in water. Both standard and intumescent foams were investigated. A series of experiments were conducted to optimize the ability of layered foam to adhere to itself without leaving "cold joints". The laboratory experiments showed that some commercially available RPF products provided good foam of the required densities under a reasonable range of simulated operational conditions. These results showed that some RPF products are eminently suitable for use in an operational water/beach environment and are capable of expanding 20 to 60 times in volume from liquid to solid state in a few minutes. One particular product, North Carolina Foam Industries (NCFI) type 811-91, was judged to fulfill specific requirements best and became the baseline for further investigations.

In parallel with the laboratory experiments, operational experiments were conducted using 2, 4, and 6 pound per cubic foot (pcf) standard RPF foam blocks prefabricated by Allied Signal. These blocks were poured using an available foam, BKC 44307, and have some properties less ideal for this application than the NCFI 811-91. This material was chosen as having representative properties and was available in time to support field experiments concurrent with the laboratory work. The use of prefabricated blocks permitted us to proceed with experiments and learn much of the RPF characteristics before choosing a large capacity, portable foam dispenser.

Two areas were of particular interest to the TCG due to their operational impact: the ability of foam to carry amphibious assault vehicles (AAV-7/AAAV) and landing craft air cushion (LCAC) traffic and the reaction of the cured foam to fire. Trafficability experiments were conducted using 2, 4, and 6 pcf foam in 54-inch cubes. The experiments were designed to ensure that the loading simulated operational conditions. Flammability experiments were conducted in two series using both 2 and 4 pcf foam. In no instance did the fire progress to a flash fire. The foam in these experiments contained no fire retardant component. The foam could have a moderate level of retardant additive. In these experiments, the foam showed a regular tendency to self extinguish, once the initiating heat was removed. In addition to trafficability and flammability, other experiments involved small arms and cannon caliber projectile impact, explosive cavity formation, and POL product compatibility.

These experiments have established that rigid foams are capable of covering a mined barrier, absorbing at least a portion of ordnance detonations, and providing a usable roadway for assault vehicles without introducing new hazards or presenting incompatibilities with other assault equipment.

Initial planning for project experiments concentrated on the two areas of most concern: trafficability and flammability. Both laboratory and full-scale experiments on trafficability have been accomplished and a series of analyses on strength/suitability and deployment were also performed. The following section describes the objectives, results, and conclusions of the more significant experiments.

### *Standard Foam Chemical Suitability*

Before doing extensive operational testing of RPF foams, it was necessary to establish their capabilities in relation to this particular application. Laboratory testing was conducted in the early fall of 1995 to verify the characteristics of the material as they related to formation under operational conditions.

One of the most important properties for this application is the chemical reaction in water. In a combat environment, it would be necessary to use the foam as soon after forming as possible. To determine how quickly the foam would be usable, its rise time, tack free time (the time until the surface of the foam is no longer sticky), and its mechanical strength as functions of temperature and of time after pouring were evaluated. The formation of interfacial voids, or faults between foam layers, was also investigated in order to prevent their formation in future foam pours. Initial characterization studies performed on the foam also examined its mechanical properties as measured by compressive strengths and the foam's performance when formed in water. Variations in water temperature, component temperature, and mixture ratio were also studied after the best candidate was selected.

Concerns about the flammability of rigid foams for combat applications led to the evaluation of an intumescent foam for this purpose. Because intumescent foams form self-protecting carbonaceous chars when exposed to high temperatures, it was believed that these foams might be more appropriate to the combat situations in which they may be used. Similar to standard polyurethane foam, the effects of foam component temperature on foamability and foam properties such as rise time and tack free time were evaluated. In addition, water immersion tests were run. The intumescent foam formulation used, General Plastics FRLI-3702, did not prove satisfactory for the obstacle breaching application because of the poor mechanical properties produced when setup in water was required. This type foam may, however, have other military uses.

Results: The mixed liquid components are higher in density than water and, therefore, sink when poured into the water. In all cases, water immersion slowed the foam formation. Cooler water temperatures had the most dramatic effect with rise time and tack free time increasing substantially with cooler water temperatures. As was expected, the reactivity increased and the density

decreased with the increasing temperature of the foam components. Warmer foam components caused shorter rise time and tack free time. Larger quantities tend to overcome lower temperatures by exothermic reaction and good internal insulation, i.e., low thermal conductivity. However, none of the environments studied stopped the materials from foaming, including an improper mix ratio. One data set is shown in Figure 2.

**Conclusions:** The behavior of the standard foam during its formation was satisfactory under all conditions within the range of these experiments. It should, therefore, prove possible to adapt these materials to the desired use.

#### *Field Full-Scale Trafficability*

In order to give the foam a credible test of how well it would be able to carry traffic loads from AAVs and other military vehicles, we conducted a rigorous series of trafficability experiments in the field. We wanted to study the amount of wear that 2, 4, and 6 pcf blocks would experience when they were driven over repeatedly by vehicles of different types and weights. To prepare for these experiments, a block of foam was placed in a wooden fixture, which was set into the ground so that the top surface of the foam was even with ground level. The top of each block was carefully measured prior to each experiment in order to set a baseline for determining wear later. Sand was compacted to form a comparable level of stiffness to the foam, so that the supports on either side of the block and the support of the block itself were about equal. Figure 3 shows a foam block in the support fixture. In conducting these experiments, we used a M60 tank and a M110 howitzer (with and without rubber road pads), a standard 6 x 6 truck with rubber tires and carrying two 5,000 lb calibrated weights, and a small firetruck. The rubber road pads were removed from one track of each tracked vehicle to gather data both with and without bare tracks. The trucks were run only at one speed; the tanks at two (dead slow and the maximum speed permitted by the distance available for acceleration: 14 mph for the M60 and 17 mph for the M110). As many as 96 passes were made over the block with the tracked vehicles and up to 105 passes with the trucks. Figure 4 shows the M60 tank traversing a 4 pcf block.

A vehicle was driven over the compacted soil and the top of the foam block. After the specified number of passes, the experiment paused and measurements were taken across the top of the foam in a 9 x 9-inch grid pattern. Figure 5 shows depth measurements being taken. In every experiment, the vehicle was maneuvered so as to make repeated passes in the same path to produce maximum rut depth, hence a worst-case condition. In practice, one would expect vehicle paths to vary by a few feet and, hence, the rut depth produced by a specific number of passes to be less than that produced in the experiments. The sweeping out of the rut before each set of measurements also would produce a worst-case situation. Experience showed that crushed foam particles and/or

sand accumulating in the ruts formed a cushion that greatly inhibited further erosion. As the experiments progressed, it became apparent that the tamped sand on either side of the foam block was eroding and softening up more rapidly than the foam was worn down. This also placed more weight on the block than on the surrounding soil resulting in a worst-case condition.

During operational assault conditions, Marine Corps tracked vehicles would normally have all road pads removed to provide better traction. When traversing the foam, the track without pads caused a significantly higher wear rate on the foam. The 4 pcf foam withstood 64 passes of each tank (with pads), 32 passes of the M110 gun (without pads), and several passes of the fire truck, all at minimum speeds. It also withstood 32 passes of the M110 gun and about 90 passes by the M60 tank at high speed. Six different 2 pcf foam blocks were tested using both the M110 howitzer and the M60.

The 2 pcf foam developed ruts rapidly when traversed by either tracked vehicle and eroded about four times as fast as the 4 pcf foam. Tracks without road pads (bare) eroded the foam slightly faster than with the pads installed. The more thickly padded M60 tracks wore less than the lighter M110. The M110 track design is considerably more aggressive than that of the M60.

**Results:** The results showed that the foam could withstand considerable vehicular traffic. Higher speeds produced more wear; however, most of the wear occurred in the first few passes. After these first passes, crushed foam particles developed that fell back into the rut and reduced the wear rate in subsequent passes. As expected, tanks with bare tracks caused more wear in the foam than did tanks with road pads or the military truck. Trucks caused less wear on the foam surface but appeared to throw crushed foam out of the ruts.

**Conclusions:** From the data recorded using the four vehicles, the following statements can be made:

Two pcf foam may be marginal for operational use with tracked vehicles such as the AAV-7 or AAAV.

Four pcf foam is more than adequate from the standpoints of both wear and strength. A foam of 2½ to 3½ pcf may be optimum for this application. Further work will establish this more accurately.

Figure 6 is an extrapolation of rut formation in 2, 4, and 6 pcf foam. Further experiments with foam that is partially or wholly supported on water are required.

#### *Flammability*

This experiment used both a 2 and a 4 pcf foam block wall approximately 5 ft square and 6 inches thick glued together from foam sections 6 x 6 x 60 inches. This experiment was designed

to simulate a plausible operational situation. The foam was ignited by a diesel oil pool fire adjacent to the wall. Thermocouples were embedded in the foam and temperature measurements were recorded throughout the experiment. The entire experiment was video taped.

**Results:** The entire front face of the foam wall was charred and was partially charred around the sides and top including parts of the back of the wall. In the 2 pcf experiment, two holes were burned completely through the 6-inch thickness where the fire intruded into cold joints in the foam. In both experiments, the foam appeared to have ignited from the radiant heat of the oil fire before direct conduction ignition was observed. The foam did self extinguish before the oil fire burned completely out. At the end of both experiments, the foam walls were still standing and appeared to be relatively sound. Figure 7 shows the setup and the 4 pcf foam wall after the experiment. Figure 8 shows the back of the same wall with the thermocouple leads visible and the burn through area marked.

**Conclusions:**

Both 2 and 4 pcf foam can be readily ignited by radiant energy. The foam did self extinguish as soon as the initiating fuel fire began to burn down. At no time did the foam support a flash fire, but burned about like soft wood. Although similar to the 2 pcf wall burn, the flame burned less deeply into the 4 pcf foam. Interior temperatures rose only slightly above ambient. Figures 9 and 10 are the time-temperature plots of the 2 and 4 pcf experiments. Smoke from the foam did not appear to be any more irritating than that from a wood and oil fire.

*Small Explosives*

In the small explosives series of experiments, we wanted to see how well the foam withstood various size charges. Previous calculations by Cooper and Kurowski of Sandia in October of 1975 were verified and their data extended empirically. In performing these experiments, we anticipated significant damage to the blocks from the large charges. 10, 100, and 1,000 gram C-4 charges were placed on the surfaces of 2 and 4 pcf blocks and detonated. Although many of the blocks fractured catastrophically, it was still possible to determine the rough size of the cavity by reassembling the bigger fragments.

**Results:** Cavity sizes compared very well with predictions based on previous work by Cooper and Kurowski. Because of the correlation, replication was considered unnecessary for this series of experiments.

		Explosive Cavity Diameters		
		0.1 gm	10 gm	100 gm
Surface	2 pcf	-2 inches	12 inches	26 inches
Embedded	2 pcf	N/A	14 inches	23 inches
	4 pcf	N/A	N/A	28 inches

A single 1,000 gram C-4 surface shot was conducted on 4 pcf foam, resulting in massive block fracture and fire. The block was too small to contain the explosion but the cavity size followed the prediction.

**Conclusions:** The results of these experiments reproduced the work of Cooper and Kurowski for embedded charges and extended the data to indicate that cavity sizes produced by surface explosions were equally well predicted by their work. There was no observed difference in cavity size between embedded and surface explosions. It appears that cavity formation is entirely the result of the pressure differential across the shock front, whereas the global damage to the block results from internally contained pressure loading.

*Cannon Caliber*

In this series of experiments, we attempted to learn the effect cannon caliber ordnance would have on the foam when shot from distances of about 100 meters. We wanted to determine how well the foam would survive a shot and whether the projectile would fuze.

**Results:** A 30 mm HE-I projectile did not fuze in the 2 pcf foam. It perforated all 54 inches of foam and detonated on the armor backing plate. A projectile penetrated the 4 pcf block, detonating in the rear third of the block depth approximately 10 to 12 inches before it would have exited. The exit cavity measured about 18 inches in diameter with a hole 38 inches in diameter at the rear surface of the target.

**Conclusions:** While these two shots are inadequate to permit much generalization, they provided the initial indications needed to plan future work. Two pcf foam is probably too light to fuze most cannon projectiles. Four pcf foam will cause some sensitive point detonating fuzes to function. The cavity diameter formed in 4 pcf foam correlated well with C-4 charges embedded and detonated. Larger artillery projectiles in the 76 to 155 mm range can be expected to produce large holes in the foam, but may or may not fuze in the foam. However, a principal characteristic of the foam system is an easy method for field repair of cavities.

*Small Arms*

In this series of experiments, we attempted to show the effect small arms ordnance would have on the foam when shot from distances of about 100 meters. We wanted to determine how well the foam would survive a shot.

**Results:** We fired four rounds (5.56 mm and 7.62 mm) that perforated the 12+ ft of foam and embedded in sandbags placed behind the foam. All four exit holes were elongated - indicating tumbling.

Conclusions: Rifle caliber small arms will not cause great amounts of damage to a foam ramp. Two or 4 pcf foams lack the density to provide any protection from rifle caliber small arms.

- RPF may be formed with acceptable properties without requiring precise mix ratios.

## Analyses

### *Preliminary Analyses*

Several analyses were done to estimate the feasibility of the basic concept. It was necessary to compare the existing data on strengths of generic foam as a function of density with the anticipated loadings. It was also necessary to scope the quantities and deployment rates which would be required in an operational application. The analyses were continually refined as more information became available from experiments and as the operational concept matured. These analyses used handbook formulas and values to begin the development process. Finite-element analyses were conducted using the ANSYS® code. These analyses were used, first, as the basis for experiment planning. As a result of these preliminary analyses, we decided with the concurrence of the TCG to proceed with experiments designed to refine our knowledge base.

### Initial Conclusions

The objective of this first phase was to examine those areas of concern in this application of RPF material, as expressed by the TCG and other Navy and Marine Corps advisors. We wanted to rapidly determine whether RPF material was suitable for military use in an assault roadway.

The results of this phase of the work clearly indicate the following:

- RPF can be formed with the required structural properties,
- RPF poses no extraordinary fire danger,
- RPF absorbs substantial blast energy with controllable and repairable results,
- RPF can be formed in/under water with acceptable properties,
- RPF is not destroyed by bullet impacts but does not offer substantial protection to troops,
- RPF material is environmentally benign when cured; however, one of the constituents is a respiratory irritant and must be handled with care,
- RPF may be formed with acceptable properties over a useful range of water and air temperatures, and

### *Fiscal Year 1997 Experiments:*

Laboratory experiments have demonstrated that for small batches of foam the required mechanical strength can be attained under a variety of temperature conditions in water. Because the reactivity of the foam materials and the time from pour to hardened foam would be so critical, it was deemed prudent to repeat portions of the laboratory series of experiments with large batches of material in the field. To this end, in the FY97 test series, a water-filled pond has been constructed, complete with simple mechanical wave making machinery. The newly acquired foam dispenser will be used to pour large batches of foam into 3 to 4 feet of water, both still and moving, to form a ramp from the water onto a simulated beach area.

Beginning in late September 1996, field experiments will be conducted to investigate foam setup in deep water; setup in moving water; foam ramp construction techniques; the filling of a fabric envelope; anti-invasion mine tilt rod tripping; and anti-tank mine pressure mitigation. Some secondary explosive experiments may be added as time and funding permit. Some experimental results from these field experiments were available in time to report to this symposium, but not in time to include in the published paper.

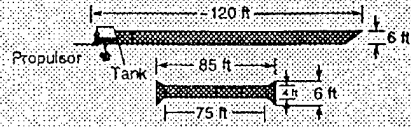
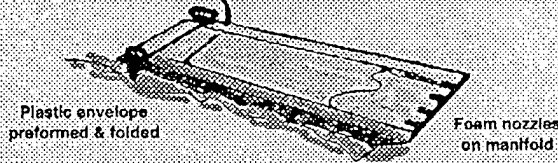
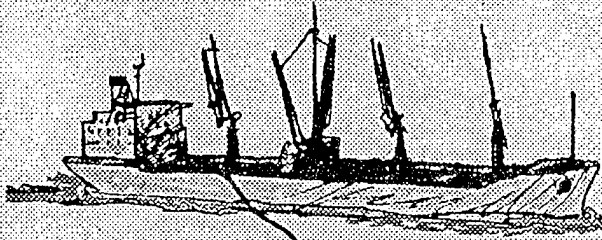
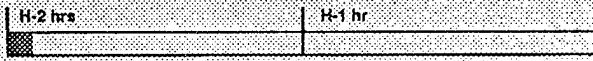
### Summary

Sandia National Laboratories is actively pursuing the practical engineering techniques involved in deploying RPF in this new application. Initial field testing in forming the foam on water have been successful and will continue through the fall of 1996. To date, there have been no "show stoppers" discovered in this feasibility study of RPF. Research and field experiments will continue, leading to the first field demonstration at the end of FY97.

### Conclusions

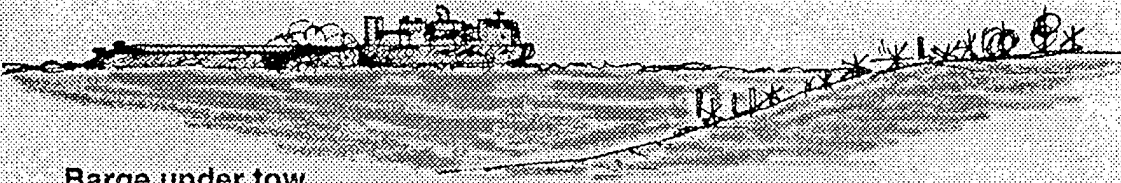
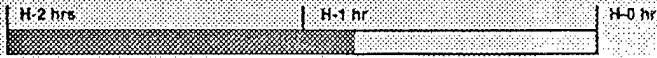
- RPF foam is useful military material.
- Deployment techniques can be developed.
- Major logistic advantage can be realized.
- Barrier crossing seems promising.

# Fill preformed plastic envelope to create barge— 25 miles out



A

# LCAC tows barge to within 500 yards



Barge under tow

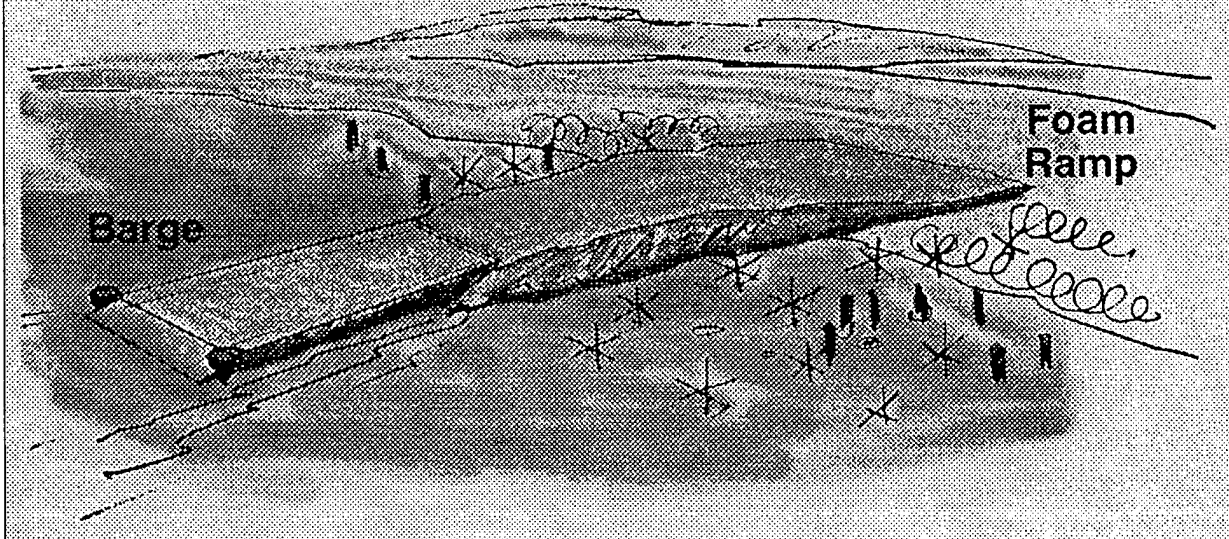
B

Figure 1. Artist's Rendition of RPF Foam Ramp Deployment



### Foam barge covers mines & obstacles

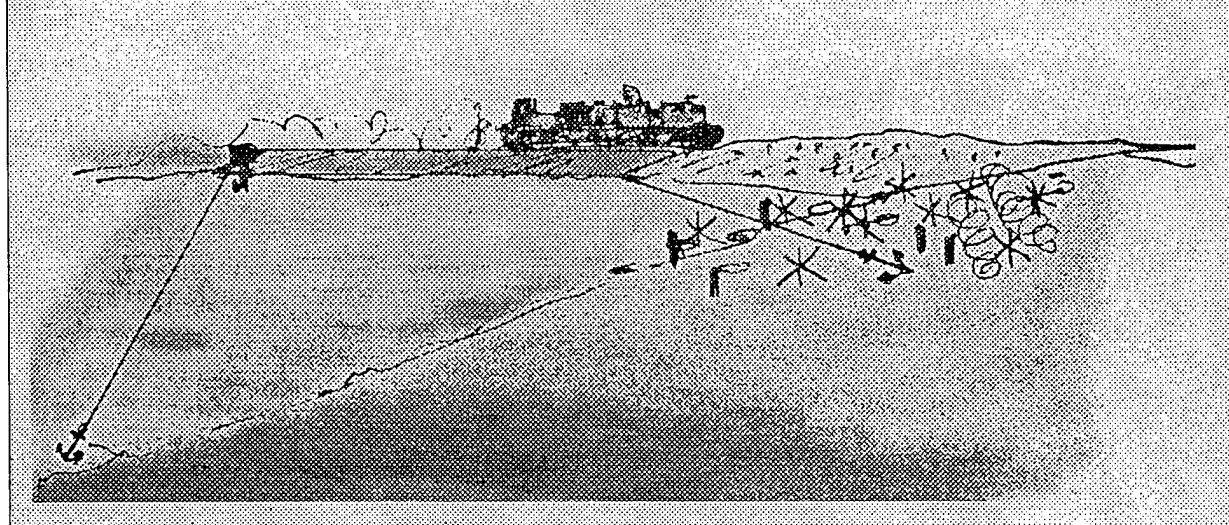
H-2 hrs | H-1 hr | H-0 hr



C

### First LCAC moves over barge & ramp to landing zone

H-2 hrs | H-1 hr | H-0 hr



D

Figure 1. Artist's Rendition of RPF Foam Ramp Deployment (Concluded)



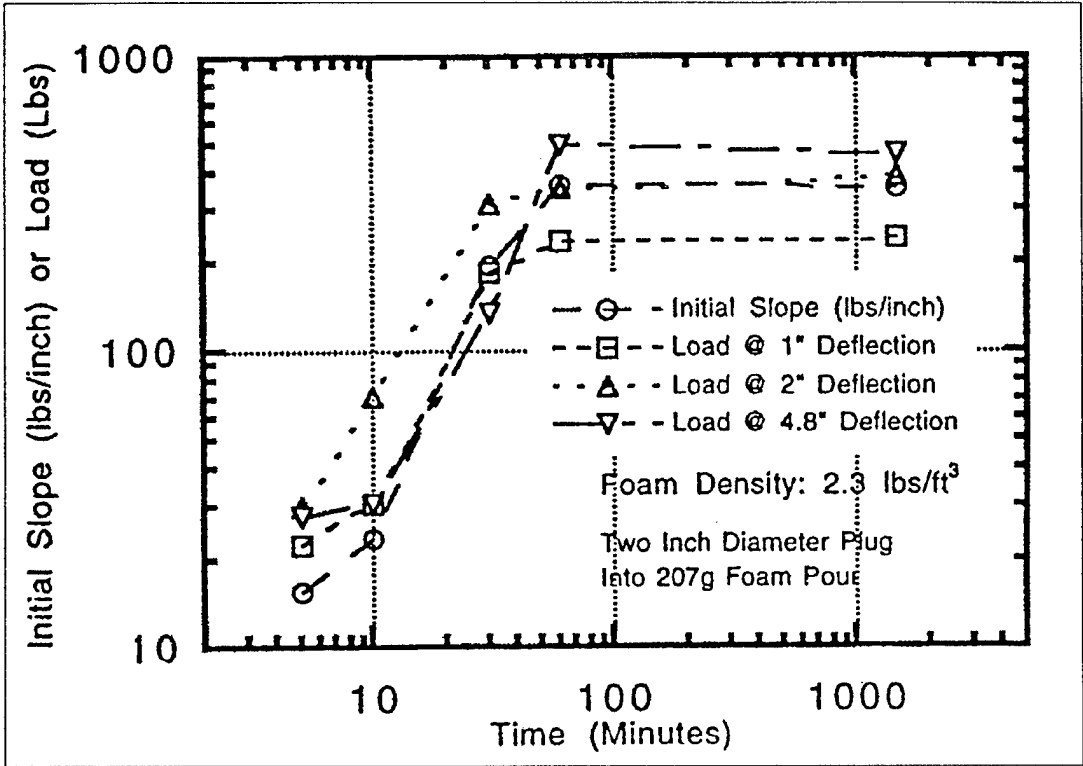


Figure 2. Plug Penetration of Foam vs Time after Foam Formation

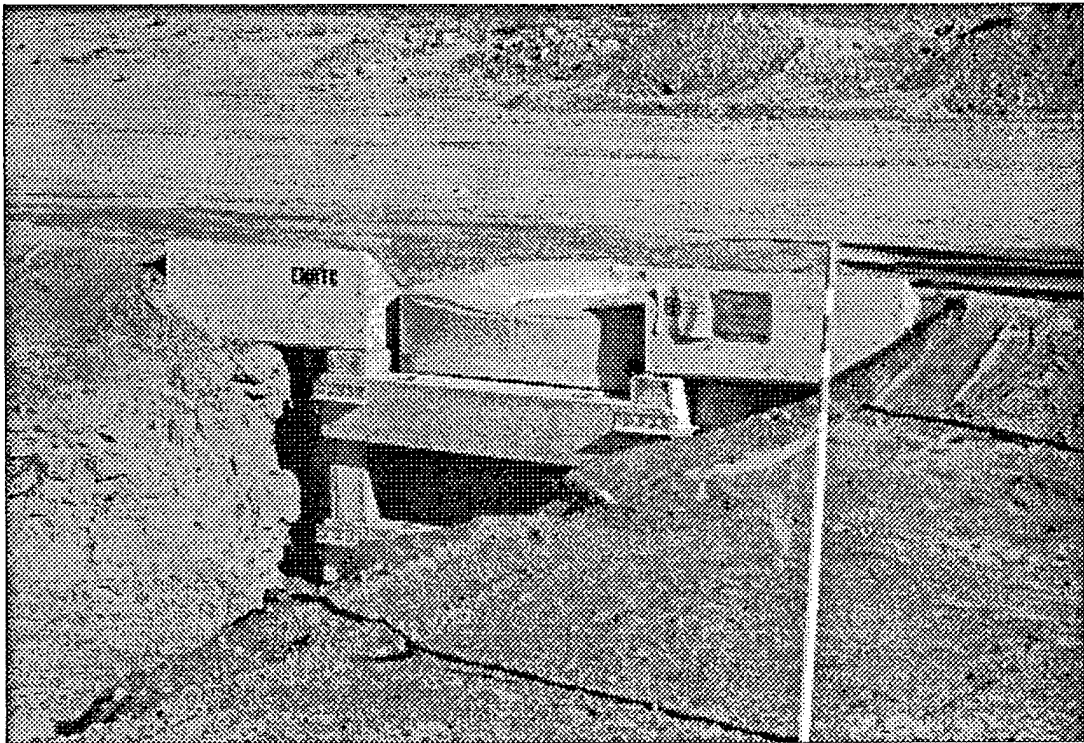


Figure 3. Foam Block Setup Complete (ready for experiment)



Figure 4. M60 Tank in a High-Speed Run over 4 pcf Foam

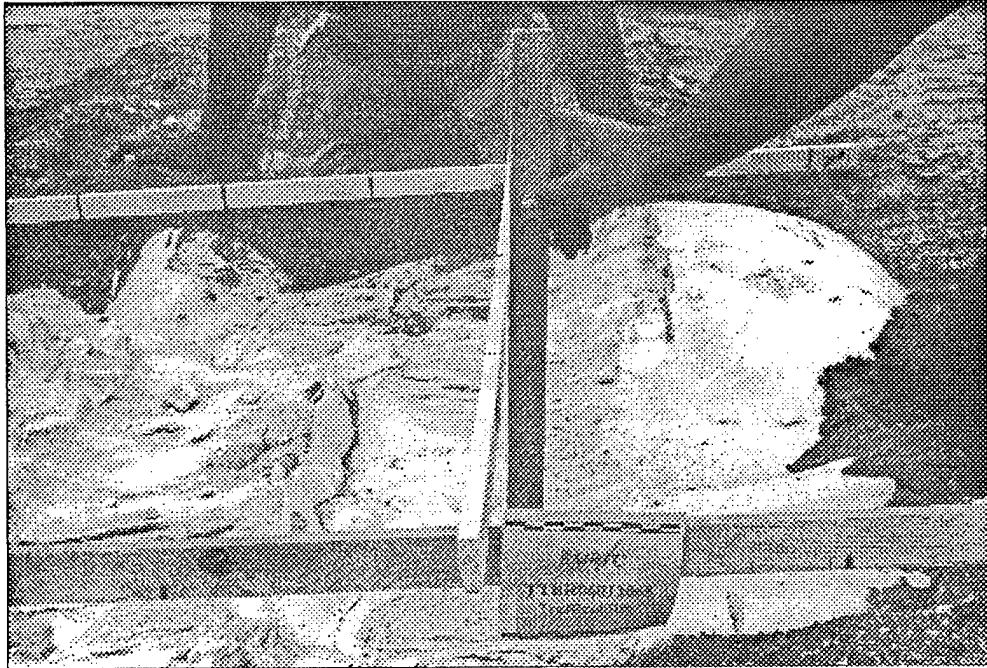
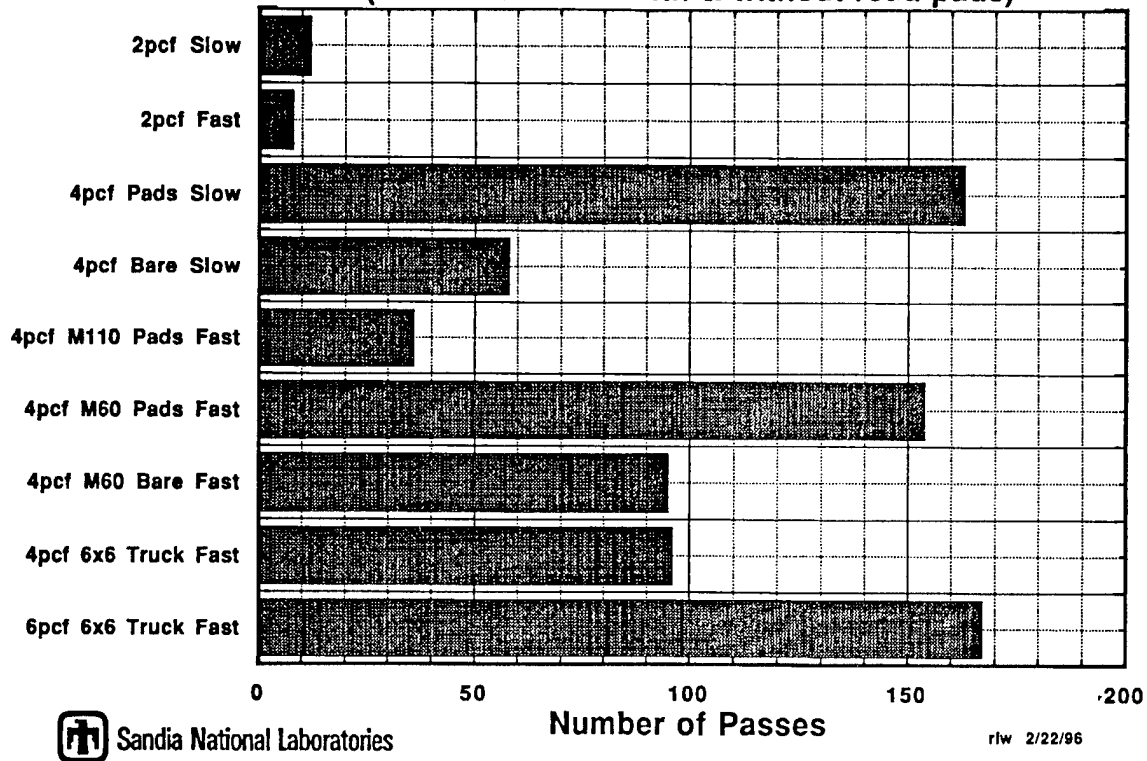
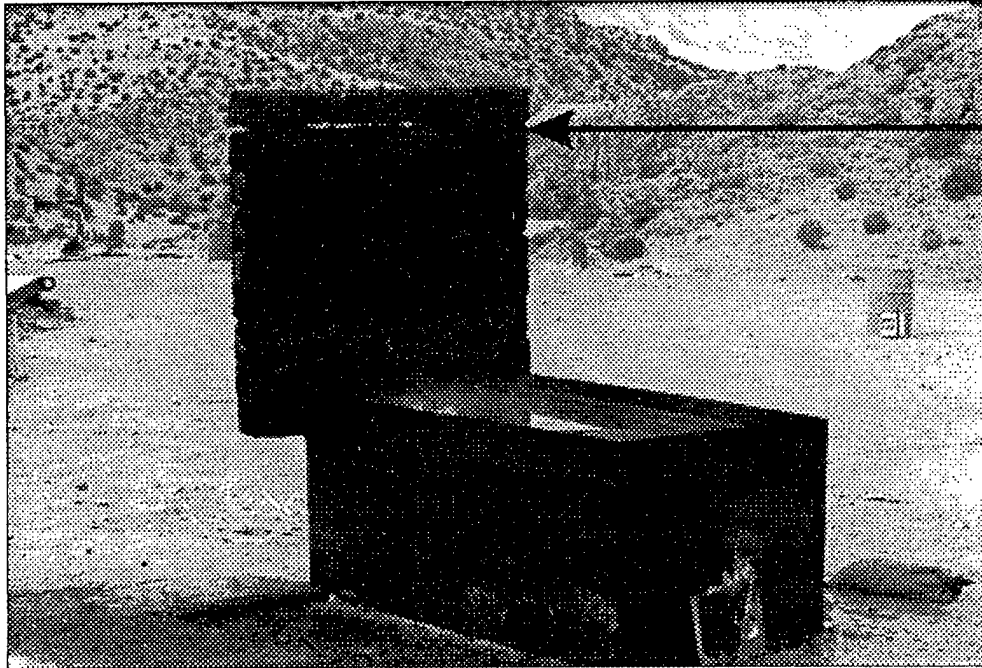


Figure 5. Taking Depth Measurements on Block #04-02

**Number of Passes Required by Military Vehicles  
to Produce 12" Deep Rut in Polyurethane Foam Blocks  
of 2 lbs/ft<sup>3</sup>, 4 lbs/ft<sup>3</sup>, & 6 lbs/ft<sup>3</sup> Density  
(tracked vehicles with & without road pads)**

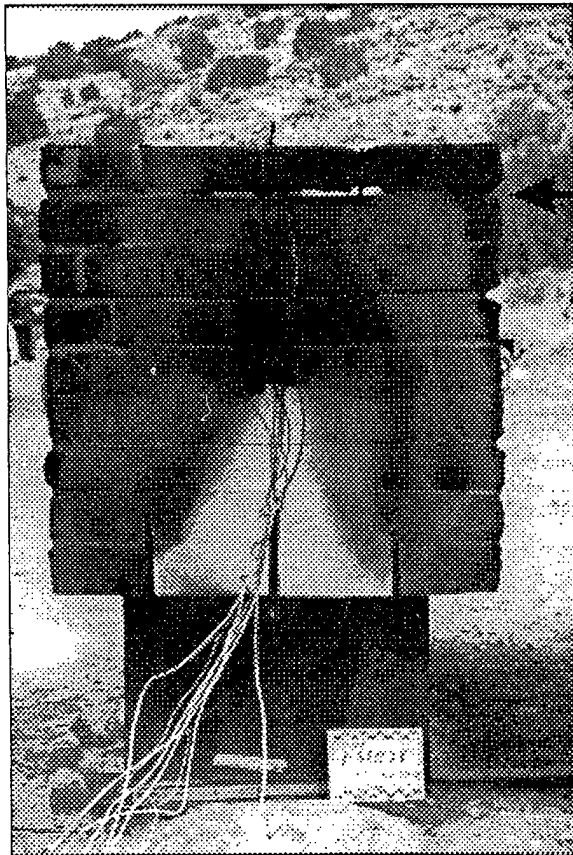


**Figure 6. Results of Initial Trafficability Experiments**



**Burn through**

**Figure 7. Flammability Experiment Configuration – Fire Out**



**Burn through**

**Figure 8. Back of Foam Wall (showing penetration damage)**

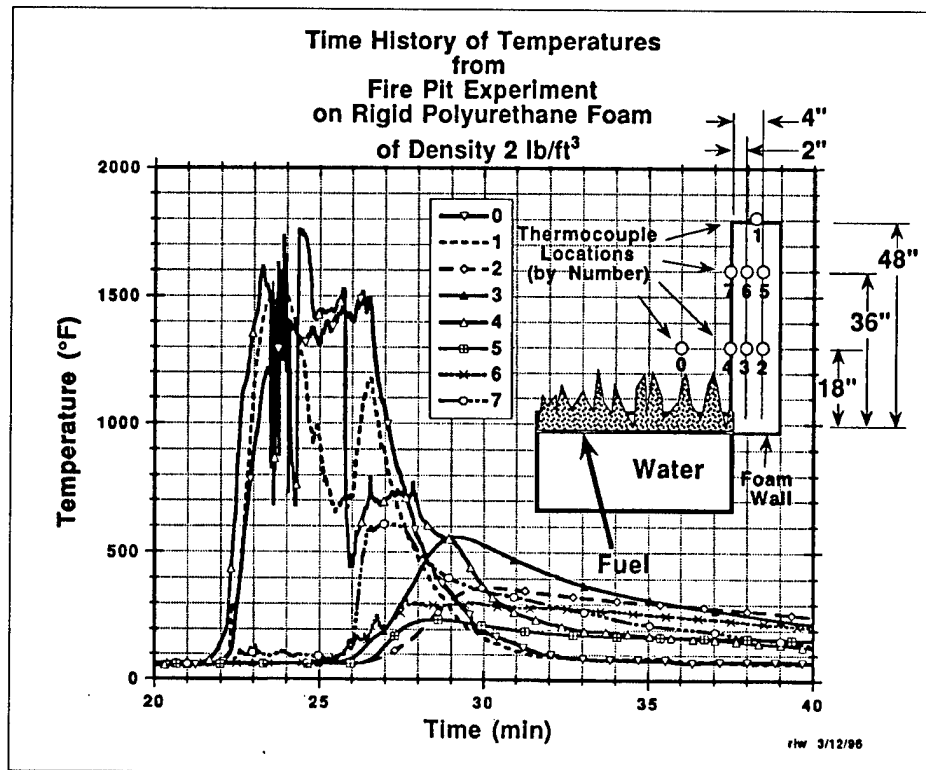


Figure 9. 2 pcf Time History of Temperatures

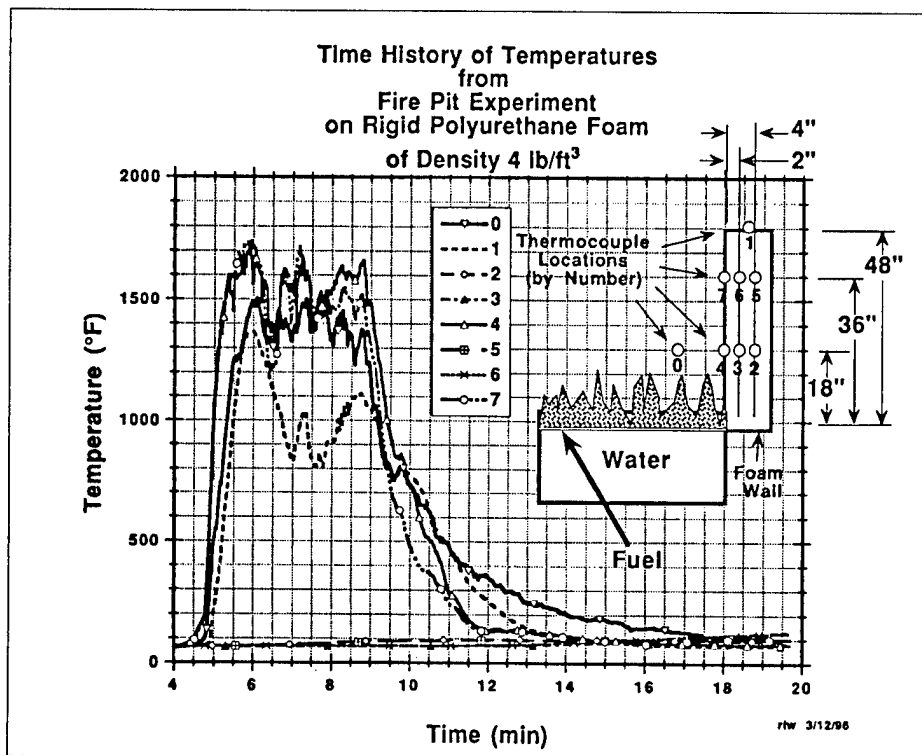


Figure 10. 4 pcf Time History of Temperatures

# **'MODS' - Mobile Ordnance Disrupter System**

**Dr. Owen Hofer**  
**SPARTA, Inc.**

The MODS presentation will cover the concept of laser ordnance neutralization. The topics of primary interest are:

- The hardware developed to date
- The laser ordnance neutralization mechanisms
- The capability demonstrated to date
- Its practical application to UXO and landmine problems
- Follow on hardware developments which will make the system smaller, more efficient, reliable and easier to use

The concept behind laser ordnance neutralization is to remotely heat a surface laid UXO or landmine via a propagating laser beam. Laboratory tests of laser ordnance neutralization had demonstrated the viability of the concept in 1975 and 1986/87. The tests demonstrated that lasers could quite rapidly and easily neutralize various UXO and landmines often causing very low-order explosions. The damage mechanism is to simply heat the munition case until the temperature of the explosive filler material exceeds its combustion temperature. In the example of metal cased munitions, case penetration, per se, is not important. The case materials (metal, plastic or wood) and the fusing concept (electronic, mechanical, magnetic, acoustical, seismic, etc.) have no effect on the neutralization effectiveness.

The MODS DEM/VAL unit was developed in 1992-1994 to demonstrate the viability of integrating a laser system onto a military vehicle (M113) and demonstrating its utility in live field demonstration tests. Live field demonstration tests were held June-August 1994. MODS successfully neutralized over 97% of UXOs tested. The munitions tested were: anti-tank land mines (BLU-97, BLU-91, TMA-3, TMA-4); anti-personnel land mines (PROM-1, PMA-3, RG-42, PP-MI-SR, and Type 69); artillery rounds (105mm, 155mm, CTG 4.2, and AO-2.5); rifle grenade (MDS-57); large general purpose bombs (MK-81, MK-82, OFAB-100/120). Engagements were performed at ranges of 25 meters to 125 meters (5.5min. Video of live tests and pictures of UXOs before and after irradiation by MODS to be shown).

The recent development of diode-pumped lasers has prompted interest in their use for the laser ordnance neutralization concept. SPARTA is currently working on a joint venture with the NAVVEODTECHDIV/ Office of Naval Research to develop a newer and lighter weight laser ordnance neutralization follow on system. Current hardware will permit the system to be integrated onto an uparmored HMMWV for used in both peacetime and combat missions scenarios to clear UXOs wherever they are located. The diode-pumped laser, which is vastly more efficient, electrically, and has better beam quality, will permit a smaller, modular system to be packaged for use on a HMMWV or on a variety of mobile platforms with an extended range out to 300 - 400 m. (>1000 ft.).



## **In-Stride Mine and Obstacle Breaching for Amphibious Assaults**

**Dr. Rudy Wiley and Kris Irwin**

Naval Surface Warfare Center, Dahlgren

**Tim Hennessey**

Naval Surface Warfare Center, Indian Head

**Phong Nguyen**

Naval Surface Warfare Center, Caderock

**Eric Scheid**

Naval Surface Warfare Center, Crane

A user-independent Analysis Engine (AE) was rigorously assembled and then applied to systematically select promising obstacle breaching solutions from a field of more than 400 candidate proposals. Assembly of the AE consisted of the following two component efforts:

- 1) derivation of a set of algorithms describing the probability of collision-free transit of the amphibious assault vehicles as a function of countermeasure or weapon effectiveness;
- 2) rigorous configuration of a set of solution spaces describing countermeasure or weapon effectiveness as a function of countermeasure or weapon type, platform, lift, placement accuracy, and threat. (The threat included an obstacle course bounded by adjoining mine fields). As a case in point, a 90% probability of successful transit criteria was arbitrarily selected and applied to the MRC(W) case. Application of the AE in this fashion suggested that the following two weapon-platform systems showed a high likelihood of success:

- 1) MCAC deployed line charges (such as ENATD) to simultaneously rubble the obstacle and mine threat in the water; and
- 2) F/A-18 deployed passive GPS guided Mk 82 bombs to rubble the obstacle threat on land by targeting on-land arrays only. (This is *not* equivalent to saturation bombing, which the AE concluded to be ineffective). Finally, it is noted that the manner in which the AE was assembled is both general and rigorous enough to allow its application to a set of proposals much larger than the field of 400 considered in this study. It is also significant that the AE may be applied to the mine countermeasure problem with equal success in formally identical fashion.

---

Because a full paper was not received by publication date, the above Abstract appears in this Proceedings. The lead author can be reached at the Naval Surface Warfare Center, Dahlgren Division.





# **Man-Portable Mine Clearing Line Charge System**

**Michael Voisine and A. Jonathan Bawabe**  
**The Ensign-Bickford Company**

The Man-Portable Mine Clearing Line Charge System developed by the Ensign-Bickford Company (EBCo) is a self-contained, lightweight, single shot, single soldier portable means for rapidly producing a cleared path through surface laid antipersonnel (AP) mines and tripwire actuated explosive devices by destroying, neutralizing or removing them. The system, which was designed to consider system safety, effectiveness and packaging, is expected to clear a 0.6 meter wide, 60 meter long safe lane/footpath through surface laid AP minefields to facilitate rescue operations, assault breaching or self-extraction from mine fields. The Man-Portable Mine Clearing Line Charge System consists of three subsystems -- initiation, safe and arm, and line charge -- packaged in a polyethylene case.- Additional hardware in the system aids in the interconnection and installation of system components.

---

Because a full paper was not received by publication date, the above Abstract appears in this Proceedings. The lead author can be reached The Ensign-Bickford Company, 660 Hopmcadow Street, Simsbury, CT 06070; telephone, 860-843-2329.



# **Mine Vulnerability**

**Joel Gaspin**

Naval Surface Warfare Center, Indian Head

To effectively evaluate and optimize explosive clearance systems, the response of threat mines to explosive effects must be well understood. This paper describes tests and analyses performed to understand explosion physics in the surf environment, including shock and bubble effects, surface cutoff, bottom refraction and the influence of the environment on explosion phenomena.

---

Because a full paper was not received by publication date, the above Abstract appears in this Proceedings. The author can be reached at the Naval Surface Warfare Center, 10901 New Hampshire Avenue, Silver Spring, MD 20903-5640; telephone, 301-394-2204.



## **Bombs for Channeling**

**Ferrell W. Furr and Reid McKeown**  
Naval Surface Warfare Center, Indian Head

The Naval Studies Board has recommended a "bold approach" to surf zone clearance utilizing large bombs, simultaneously detonated, to create a wide channel. Analytical tools have been developed to predict the channeling effect of a line of bombs in varying configurations and environmental conditions. This paper presents modeling techniques and comparisons to existing data.

---

Because a full paper was not received by publication date, the above Abstract appears in this Proceedings. The lead author can be reached at the Naval Surface Warfare Center, Indian Head Division, 101 Strauss Avenue, Indian Head, MD 20640-5035; telephone, 301-743-6742.



# **Deployment Modeling**

**Kennard Watson and Dr. Thai Nguyen**

Coastal Systems Station  
Naval Surface Warfare Center

Current technology demonstrations and acquisition programs in Shallow Water MCM feature line charges and explosive arrays launched from LCAC for clearance of surf zone mines. Deployment of the rocket-launched systems is critical to their effectiveness. A predictive modeling capability has been developed to simulate line charge and array deployment in varying environmental conditions. This presentation will show the purposes for the models, the physics incorporated into the simulation, and comparisons with test data.

---

Because a full paper was not received by publication date, the above Abstract appears in this Proceedings. The lead author can be reached at the Naval Surface Warfare Center, Coastal Systems Station, Code R11, 6703 W. Hwy 98, Panama City, FL 32407-7001; telephone, 904-234-4643; e-mail, <watsonk@atcf.ncsc.navy.mil>.





# CHAPTER 9: THE UNDERLYING SCIENCE OF MINE WARFARE SYSTEMS

## PHYSICS OF MINE WARFARE SYSTEMS

In the process of organizing this Symposium it became apparent that certain contributors were approaching the Mine Problem from fundamental scientific vantage points. Some of the papers in this Chapter are tutorial in nature; some present basically original work on the scientific underpinnings of the Mine Problem (see, for example, the paper by Prof. Carl Schneider, Physics Department, United States Naval Academy).

This Chapter contains some, but not all, of the papers at the Symposium which dealt with the underlying physics of the Mine Problem. For instance, it seemed more appropriate to present the paper by Dennis Hiscock, former Head of Mine Countermeasures for the Royal Navy, which includes an excellent review of influence sensors for mines and the history of experience in countering them, in the Chapter on Countering Mines at Sea, Chapter 7. Also, the presentation by Joel Gaspin, the Abstract of which appears in Chapter 8, was an outstanding elucidation of the damage mechanisms of underwater explosions and why the inherent instability of the surf zone makes modeling and prediction of mine performance in these environments extremely challenging.

According to a number of presenters, the combination of established physical theory, the fundamental parameters of sensors and structural and energetic materials, and the physical nature of the environment together set the performance envelopes within which mine warfare systems must operate. While these envelopes are most economically and elegantly described and examined mathematically, they may best be appreciated by both other scientists and nonspecialists when stated in terms of descriptions of actual controlled experiments and specific practical applications.

In future Symposia, we hope to continue the practice of inviting physics-based tutorial papers. There are many areas of potentially great significance, such as the use of very high intensity pulsed power, that cry out for physical documentation. There is also the potential of a fundamental upheaval in the ways in which modeling and simulation are developed and applied. In 1997, the National Academy of Sciences is completing an examination of ways to improve the match between models and physical reality. There are also, as yet, only dimly perceived frontiers for biologically based systems and sensors. All are subjects for future scientific elucidation.

At this Symposium on Technology and the Mine Problem, we are grateful that Dr. R. Norris Keeler, of KAMAN Aerospace and former Director of Navy Technology in the Naval Material Command, chaired this Session on the Physics of Mine Warfare Systems. We are also grateful to the distinguished contributors who made this a memorable Session.



# Automated Task Division and Group Behavior in Autonomous Robots

Maja J Matarić

Volen Center for Complex Systems  
Computer Science Department  
Brandeis University  
Waltham, MA 02254-9110  
maja@cs.brandeis.edu  
<http://www.cs.brandeis.edu/~maja>

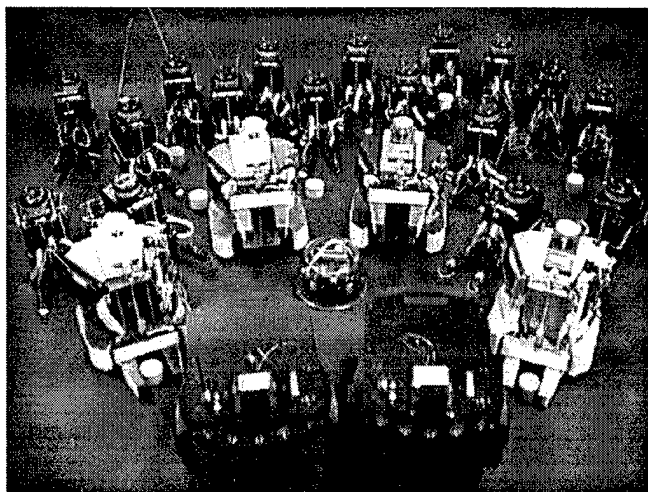


Figure 1: The experimental vehicles used for validating our methodologies and approaches to multi-robot control and learning. The group consists of 26 robots: 20 IS Robotics R1 robots, 4 IS Robotics R2e robots, and 2 RWI Pioneer robots.

## Abstract

**Abstract-**Our work focuses on developing strategies for synthesizing and analyzing group behavior. In this paper we briefly describe our methodology for synthesis of robust controllers for various multi-robot spatial tasks. Our experiments focus on foraging, a prototypical task that transfers directly to de-mining applications.

We are pursuing a research program focused on studying, synthesizing, and analyzing group behavior and learning in situated agents. The goal of the research is to understand the types of simple local interactions which produce complex and purposive group behaviors. The research is tested and validated on a group of up to 26

mobile robots, shown in Figure 1. We have developed a synthetic, bottom-up, behavior-based approach that can be used to structure and simplify the process of both designing and analyzing emergent group behaviors. The approach utilizes a biologically-inspired notion of basis behaviors as a substrate for control and learning both at the individual and collective level (Matarić 1995*a*).

We have developed a basis behavior set for embodied, mobile agents interacting in complex domains, consisting of safe-wandering, homing, following, dispersion, and aggregation behaviors. We then introduced methods for selecting, formally specifying, algorithmically implementing, and empirically evaluating basis behaviors. Additionally, we described how basis behaviors can be combined and sequenced to produce higher-level composite behaviors, such as flocking and foraging. We have used these behaviors to study interaction dynamics of animals as well as to develop controllers for real-world applications including de-mining, oil-spill cleanup, terrain exploration and mapping, toxic waste cleanup, and agricultural applications and space applications (Matarić 1995*b*).

After developing the basis behavior methodology, we introduced an adaptation of reinforcement learning that allows for automatically constructing higher-level behaviors by having the agents learn, in real-time, to select from the basis set. The formulation involves the use of conditions, behaviors, and shaped reinforcement, thus making behavior selection learnable in noisy, uncertain environments with stochastic dynamics, such as that of four or more interacting physical mobile robots (Matarić 1994*b*, Matarić 1996*a*). The learning approach was demonstrated on multiple tasks, including a group of 4 robots learning to forage (Matarić 1996*b*), 4 robots learning social rules (yielding and information-sharing) (Matarić 1994*a*), and 2 robots learning to cooperate and communicate in pushing a box (Simsarian & Matarić 1995). These experiments spanned both loosely-coupled and tightly-coupled task domains. We are currently exploring methods for reinforcement-sharing with the goal

of learning cooperative tightly-coupled tasks (Mataric 1996c). We are also developing a methodology for learning from history, to be applied to the robots automatically selecting alternative behaviors and controllers as the dynamics of the world change during the lifetime of the task. Similarly, we are exploring the establishment and maintenance of dominance hierarchies, their computational requirements (i.e., the amount of internal state, mental modeling, and history required), and their effect on the dynamics of group interaction.

We are also exploring ethologically-inspired variations on group organization, using foraging as the prototypical task. We have implemented homogeneous, caste, pack, and territorial versions of foraging, using only small perturbations in the controller (Fontán & Mataric 1996, Goldberg & Mataric 1996). Now we are developing methods for automatically switching between those controllers/regimes as the dynamics of the world/task change, based on local information available to each agent. In conjunction, we are working on methods for analyzing such complex multi-robot and multi-agent systems; one of our current approaches features behavior activation time-series analysis.

## References

- Fontán, M. S. & Mataric, M. J. (1996), A Study of Territoriality: The Role of Critical Mass in Adaptive Task Division, in P. Maes, M. Mataric, J.-A. Meyer, J. Pollack & S. Wilson, eds, 'From Animals to Animats 4: Proceedings of the Fourth International Conference on Simulation of Adaptive Behavior', MIT Press, pp. 553-561.
- Goldberg, D. & Mataric, M. J. (1996), Interference as a Guide for Designing Efficient Group Behaviors, Technical Report Computer Science CS-96-186, Brandeis University.
- Mataric, M. J. (1994a), Learning to Behave Socially, in D. Cliff, P. Husbands, J.-A. Meyer & S. Wilson, eds, 'From Animals to Animats: International Conference on Simulation of Adaptive Behavior', pp. 453-462.
- Mataric, M. J. (1994b), Reward Functions for Accelerated Learning, in W. W. Cohen & H. Hirsh, eds, 'Proceedings of the Eleventh International Conference on Machine Learning (ML-94)', Morgan Kaufman Publishers, Inc., New Brunswick, NJ, pp. 181-189.
- Mataric, M. J. (1995a), 'Designing and Understanding Adaptive Group Behavior', *Adaptive Behavior* 4(1), 50-81.
- Mataric, M. J. (1995b), 'Issues and Approaches In the Design of Collective Autonomous Agents', *Robotics and Autonomous Systems* 16(2-4), 321-331.
- Mataric, M. J. (1996a), Learning in Multi-Robot Systems, in G. Weiss & S. Sen, eds, 'Adaptation and Learning in Multi-Agent Systems', Vol. Lecture Notes in Artificial Intelligence vol. 1042, Springer-Verlag, pp. 152-163.
- Mataric, M. J. (1996b), 'Reinforcement Learning in the Multi-Robot Domain', *Autonomous Robots*.
- Mataric, M. J. (1996c), Using Communication to Reduce Locality in Distributed Multi-Agent Learning, Technical Report Computer Science CS-96-190, Brandeis University.
- Simsarian, K. T. & Mataric, M. J. (1995), Learning to Cooperate Using Two Six-Legged Mobile Robots, in 'Proceedings, Third European Workshop of Learning Robots', Heraklion, Crete, Greece.

# The Physics of Magnetic Signatures

Carl S. Schneider  
 Physics Department  
 United States Naval Academy  
 Annapolis, MD USA 21402

**Abstract.** Reduction of magnetic signatures of ships is essential to ensure their magnetic invisibility. Maxwell's equations are used to picture the sources of magnetic signatures, their dependence upon environmental stresses, and the feedback degaussing necessary to reduce them below background noise. The intent is to be rigorous but simplistic in order to provide concepts useful to the mine warfare community.

Ten thousand tons of steel in the Earth's magnetic field becomes magnetized and generates a signature detectable by mines and aircraft. When an aircraft flies over the ocean surface, its distance from ships exceeds their lengths, and the signatures are those of magnetic dipoles.

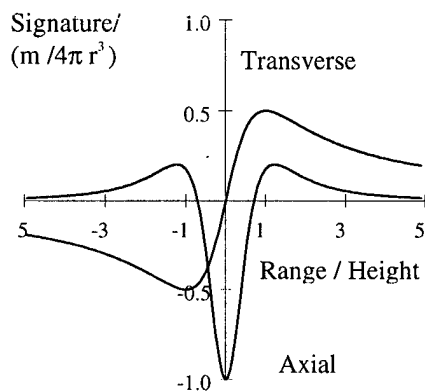


Figure 1. Transverse and axial magnetic dipole signatures seen flying parallel to a dipole axis.

The axial signature is symmetric while the transverse signature is antisymmetric with respect to distance along the dipole axis. Analytically, the signature components of a vector dipole are

$$\vec{S} = \begin{pmatrix} 3x^2 - r^2 & 3xy & 3xz \\ 3xy & 3y^2 - r^2 & 3yz \\ 3xz & 3yz & 3z^2 - r^2 \end{pmatrix} \frac{\vec{m}}{4\pi r^5} \quad (1)$$

where  $z$  is the height of observation,  $y$  is the lateral displacement,  $x$  is the range length and  $\vec{m}$  is the magnetic moment. The magnetic dipole moment of a vessel is its magnetization density multiplied by its volume.

$$m = M V = \chi H_{\text{eff}} V = \mathcal{M} \chi H_{\text{eff}} / \rho \quad (2)$$

The magnetization density is the material magnetic susceptibility,  $\chi$ , multiplied by the local or effective magnetic field and the volume is the steel displacement,  $\mathcal{M}$ , divided by the density of steel. A rough estimate of the magnetic signature of a ship is  $S = H\mathcal{M}/r^3$  where  $H$  is the Earth's field,  $\mathcal{M}$  is in tons of steel and  $r$  is in meters.

Knowing the displacement of a ship, we review below the material susceptibility and how the local field derives from the Earth's magnetic field. Figure 2 shows a single crystal or grain of ferromagnetic material such as iron or steel, which is several microns across.

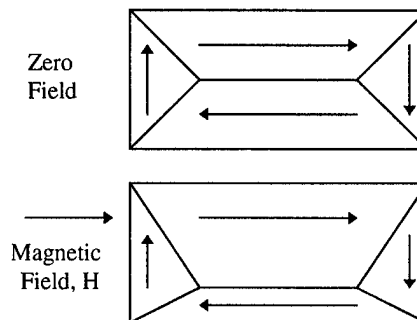


Figure 2. A ferromagnetic grain is magnetized by domain wall movement and domain rotation.

In the unmagnetized state, regions called domains, with all the atoms magnetically aligned, connect into a symmetric closed loop to give zero magnetization. When a magnetic field is applied, the central wall moves to increase the size of the domain magnetized closest to the direction of the applied field. Within the crystalline domains, the atomic magnetism will also rotate in direction, resisted by the crystalline

stiffness or anisotropy constant. In ship steel both contributions are comparable and give a net magnetic susceptibility of 80.

This susceptibility is nearly constant for induced magnetization. This is due to magnetic fields such as the Earth's, about 50 A/m between the middle latitudes. Larger fields are used in deperming and degaussing, or are due to lightning, or equivalent to stresses from diving, surfacing or transiting a thermocline. They create higher susceptibilities, hysteresis and permanent magnetization. The primary reluctance to magnetization in hull steel is from residual stress, which is about 110 MPa. It is the source of and is thermodynamically equivalent to the coercive field of Figure 3, about 700 A/m or nine oersted in the cgs system of units.

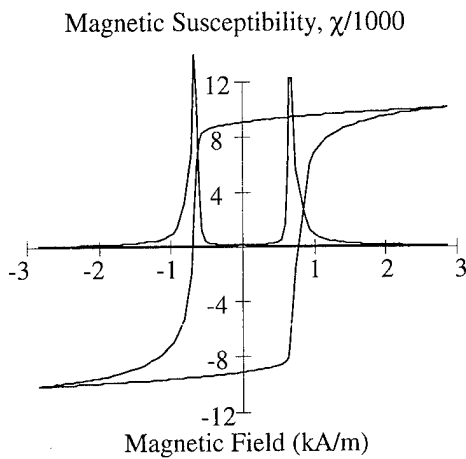


Figure 3. Magnetic susceptibility of hull steel shown with the major hysteresis curve (Bx6000).

At this field the domain walls are forced past most of the defects in each grain and the magnetization moves quickly toward saturation. The peak susceptibility exceeds 12,000 at the coercive field, and then declines to zero as the field becomes infinite.

The local field,  $H_{eff}$ , is not simply the Earth's magnetic field because the signature of the ship reduces the field on the ship's steel. This self-reduction in magnetic field is called shape demagnetization, to distinguish it from the demagnetization performed at Naval bases using coils of current. To create a homogeneous distribution of steel, imagine it to be distributed uniformly over the full volume of the ship. The susceptibility, proportional to the magnetization

per volume, is reduced by the specific gravity of steel and multiplied by the fraction of the ship below water. A fraction of 2/3 is consistent with the ship's buoyancy and stability, allowing its center of mass to be below water level. The effective susceptibility is  $2\chi/3\rho_{sp} = 80/13 = 6$  for an observer outside the ship.

The ends of this homogeneous ship now exhibit boundaries in magnetization, which are its North and South magnetic poles. Gauss' Law for magnetism requires no monopoles in B:

$$\vec{\nabla} \cdot \vec{B} = 0 \text{ where } \vec{B} = \mu_0 (\vec{H} + \vec{M}) \quad (3)$$

$$\text{so } \vec{\nabla} \cdot \vec{H} = -\vec{\nabla} \cdot \vec{M}.$$

Integrating the divergence over a spherical volume containing the pole gives the pole strength,  $q_M = MA$ , which equals the outgoing magnetic field times the area of the sphere passing through the point of observation.

$$\oint \vec{H} \cdot d\vec{A} = -\oint \vec{M} \cdot d\vec{A} \text{ and} \quad (4)$$

$$H = -M (A / 4\pi r^2) = -DM$$

The signature for a cylinder is thus the magnetization density multiplied by the solid angle subtended by both poles at the point of observation, the demagnetization factor for the poles. The field of a magnetized ellipsoid is shown in Figure 4.

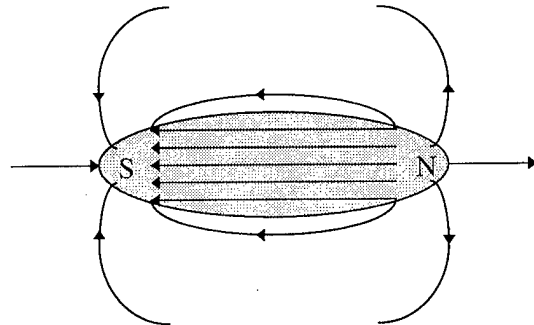


Figure 4. The magnetic field of a magnetized ellipsoid is uniform within the body and nearby.

The effective field in this magnetized steel, and just outside of it, is

$$H_{eff} = H - DM = H - \chi DH_{eff} \quad (5)$$

$$H_{eff} = H / (1 + \chi D)$$

From Equations (1) and (2), far field signatures are proportional to  $\chi H_{eff}$ . The

dependence of magnetic moments on  $\chi D$  is shown in Figure 5. Combining equations (2) and (5), the near field signature of an object at beam depth, within a ship diameter of the hull, is

$$\begin{aligned}\bar{S} &= -D\bar{M} = -\chi D \bar{H}_{\text{eff}} \\ \bar{S} &= -\bar{H} \chi D / (1 + \chi D)\end{aligned}\quad (6)$$

where  $\chi$  is the effective susceptibility and  $D$  is the demagnetizing factor. The dependence of keel signatures upon  $\chi D$  is plotted in Figure 5.

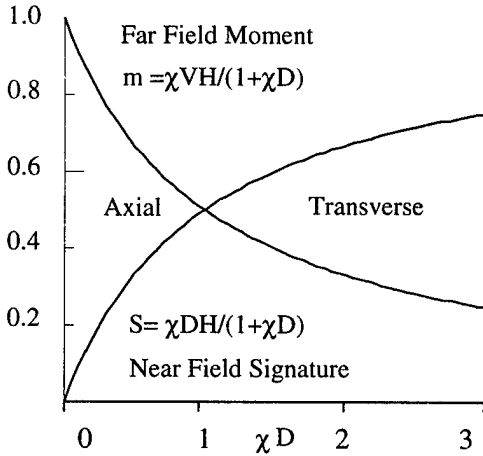


Figure 5. Magnetic shape causes axial moments to dominate at far field and transverse moments to dominate at near field.

For any three-dimensional ellipsoid, the sum of the three demagnetization factors is unity.

$$D_L + D_A + D_V = 1 \quad (7)$$

By symmetry, the sphere has demagnetization factors of  $1/3$  in each of the Longitudinal, Athwartship and Vertical directions. For a prolate spheroidal ship of length six times its diameter, Bozorth gives a  $D_L$  a value of .05. The transverse demagnetization factors are thus  $D_A = D_V = .47$ , just less than  $1/2$  for an infinite cylinder. The transverse value of  $\chi D_A$  is 2.8 for a ship while the axial value of  $\chi D_L$  is 0.3; since moments vary as  $1/(1+\chi D)$ , the ratio of transverse and axial moments and far field signatures is  $.22/.77 = .35$  for a ship with corrections for discrete vertical components such as the bridge and launch tubes which increase the vertical moment. Far field signatures reduce to  $100 \gamma$ ,  $\gamma$ , which is about  $10^{-3}$  times the

Earth's field, at 200m distance, about one ship length. Magnetic detectors can sense orders of magnitude smaller signatures than this, but must discriminate against magnetic noise such as passing clouds generating  $100\gamma$ .

The near field or keel signature is  $\chi D/(1+\chi D)$  times the Earth's field in that direction. For the above ship, this fraction is 0.25 in the axial direction and .73 in the transverse direction. Despite the approximate nature of these calculations, there is a clear distinction between defense against Magnetic Anomaly Detectors and mines in littoral waters.

The stability of the magnetic state under the stresses of waves, thermal expansion and depth can be determined from the energy density in a domain.

$$\frac{3}{2} \lambda_s \sigma \sin^2 \theta_\sigma - H B_s \cos \theta_H + \frac{1}{2} D M_s B_s \cos^2 \theta_D \quad (8)$$

including energy from magnetoelastic stress, magnetostatic field and magnetostatic shape. Equivalent changes in energy due to stress and field suggest a stress-effective magnetic field

$$H_\sigma = -3\lambda_s \sigma \cos \theta_\sigma / B_s \quad (9)$$

first observed by Brown in 1949. This field is positive, zero and negative depending on the relative values of  $\cos \theta$  across each domain wall. Changes in energy due to demagnetization suggest a stress-demagnetization factor

$$D_\sigma = 3\lambda_s \sigma / M_s B_s \quad (10)$$

and this was observed to increase linearly with negative stress and slightly with positive stress exceeding the residual stress, called the Villari reversal. The total internal magnetic field in steel is then

$$H_{\text{int}} = H + H_\sigma - D_\sigma M \quad (11)$$

where  $H$  is the Amperian field due to currents as described by Ampere's law:

$$\bar{\nabla} \times \bar{H} = \bar{J} \quad \text{or} \quad \oint \bar{H} \cdot d\bar{l} = I \quad (12)$$

Samples have been prepared as hollow cylinders to allow axial stress and azimuthal or



hoop magnetic field to be applied and removed in any order. Applied magnetic fields up to 5000 A/m and stresses up to 440 MPa are far in excess of the coercive values of 700 A/m and 110 MPa, but less than yield stress of 550 MPa. The resulting changes in magnetic induction are sensed by voltages generated across the secondary or pickup turns on the sample according to Faraday's law:

$$\vec{\nabla} \times \vec{E} = -\frac{d\vec{B}}{dt} \quad \text{or} \quad \oint \vec{E} \cdot d\vec{l} = V = -NA \frac{dB}{dt} \quad (13)$$

where N is the number of secondary turns on the sample and A is the area across the magnetic flux. By processing this voltage through an integrating operational amplifier of time constant RC, the induction, which can be plotted, becomes

$$B = VRC/NA. \quad (14)$$

Stress-induced magnetization,  $H\sigma$ , can cause the magnetic induction to increase by factors greater than ten, as shown in Figure 6.

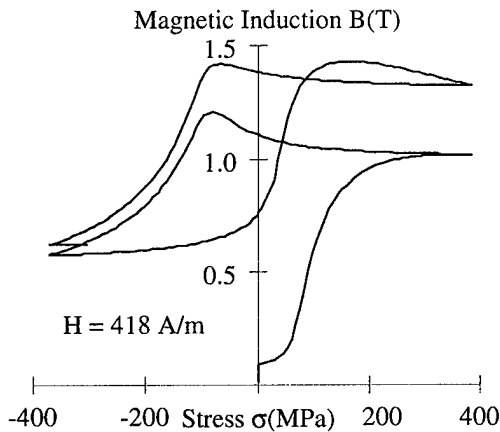


Figure 6. Stress cycling in a magnetic field causes increases in magnetization.

The effects of stress near yield are nonlinear, hysteretic and multi-valued: magnetization creeps toward equilibrium. Significant effects of stress occur in magnetic fields as small as the Earth's field. The effective stress on a hull is the difference between longitudinal and azimuthal stresses. The azimuthal or hoop stress is positive and twice the magnitude of the negative longitudinal stress for an unreinforced cylinder. Ribs on the hull, however, reduce the hoop stress to nearly equal the longitudinal stress: up to 400 MPa individual stresses create about 40 MPa net

stress, and permanent magnetization as shown in Figure 7.

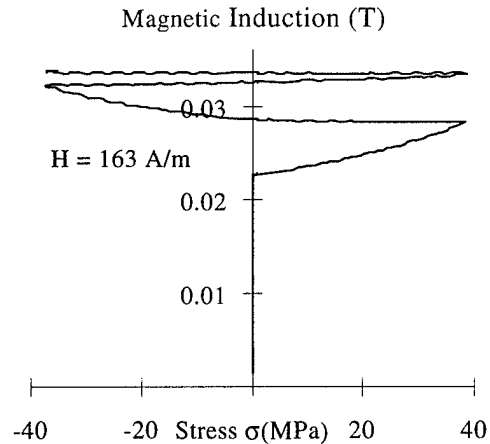


Figure 7. Net hull stress in small magnetic fields causes a fifty per cent increase in magnetization.

Positive and negative stress effects are shown to demonstrate the activation of both domain wall types. Thermal stresses can fracture a cold ice cube dropped into a glass of water. A thermal difference of ten degrees Kelvin creates 150 ppm of strain in iron and 30 MPa stress on a hull, comparable to those from depth.

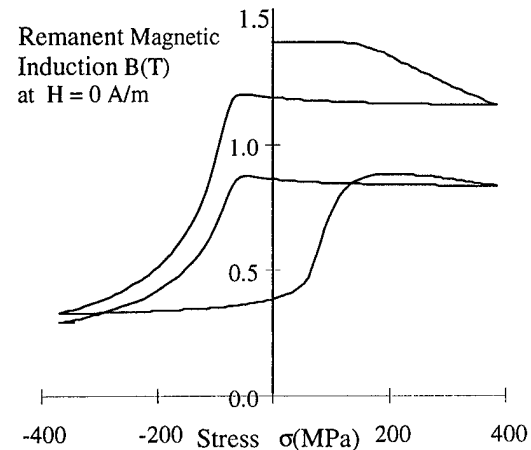


Figure 8. Magnetization decreases with stress changes in the absence of magnetic field.

When stress is applied in zero magnetizing field, remanent magnetization decreases toward equilibrium. In order to compute changes in magnetization using the net internal field, we plot the magnetic induction against the total internal field for positive and negative domain wall types. For stress applied on a North heading, followed by a turn South,

stress relief and return to North heading, the maximum field experienced by both domain types is  $H+H_{\sigma}$ .

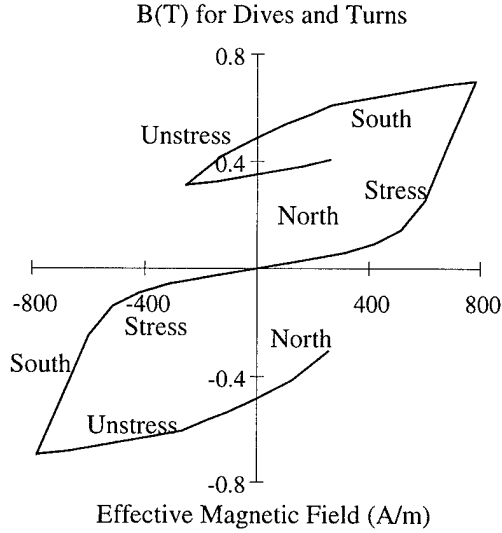


Figure 9. Symmetry of effective field causes zero net magnetization for stress with turns.

The ship permanent moment is no longer sensitive to turns. This operation cleans the longitudinal magnetization of a ship and reduces the electrical power needed for degaussing.

How many coils are necessary to degauss a ship? In moving closer to a ship, more structure becomes visible than can be described by one three-component magnetic moment. Differences in the longitudinal distribution of induced and permanent magnetization reveal magnetic poles at higher susceptibility shifting amidship. This effect requires a second triaxial magnetic dipole in any model, and the internal structure of the ship requires more. At keel depth, one ship diameter below the centerline, we can define one triaxial magnetic dipole for each diameter of length, and can describe the magnetic state of a ship in great detail. Generalized vectors of the magnetic signature, magnetic state and the degaussing coil currents must be defined:

$$\begin{aligned}\bar{S} &= (H_{x1}, H_{y1}, H_{z1}, H_{x2}, \dots, H_{zq}) \\ \bar{m} &= (m_{x1}, m_{y1}, m_{z1}, m_{x2}, \dots, m_{zp}) \\ \bar{I} &= (I_1, I_2, I_3, \dots, I_n)\end{aligned}\quad (15)$$

The number of triaxial signature measurements,  $q$ , must exceed or equal the number of magnetic dipoles and the number of coil currents for least squares optimization. The evaluation of dipole

magnitudes can be explicit, or the current can be directly calculated to degauss the ship. Signatures measured both shipboard,  $S_H$ , and externally at beam depth,  $S_K$ , enable development of a control matrix between signature sensors and degaussing coils. Cylindrical ship symmetry would enable a single line of  $q$  triaxial sensors to suffice. Asymmetry requires that field sensors be more distributed over the hull volume and keel sensors on a surface around the vessel.

In order to solve for coil currents, we ascribe the signatures to two sources: degaussing coil currents and hull magnetic moments. The existing hull signatures and required keel signatures with the new coil currents are,

$$\bar{S}_H = \alpha_H \bar{I}_0 + \beta_H \bar{m} \quad (16)$$

$$\bar{S}_K = \alpha_K \bar{I} + \beta_K \bar{m} = 0 \quad (17)$$

The keel condition of zero signature zeros the signature at all points in space outside the ship just as an electrical ground zeros the external electric field for a charge distribution. The  $\alpha$  or coil signature matrix and  $\beta$  or magnetic state signature matrix can be measured by exciting the coil currents and magnetic states one at a time. Each signature is a row in the matrix. The magnetic states can be generated using the remanent or hysteretic magnetic effects of an alternating current in each degaussing coil. If these signature matrices do not describe all signatures, the degaussing coils are not complete: they do not form a Hilbert Space. Multiplying Equation (9) by the transpose of  $\beta_H$  and Equation (10) by the transpose of  $\alpha_K$  completes the least square optimization, creating square matrices which can be inverted to solve for the currents and moments.

$$\beta_H^t (\bar{S}_H - \alpha_H \bar{I}_0) = \beta_H^t \beta_H \bar{m} \quad (18)$$

$$\alpha_K^t \alpha_K \bar{I} + \alpha_K^t \beta_K \bar{m} = 0 \quad (19)$$

The required coil currents are then

$$\bar{I} = -(\alpha_K^t \alpha_K)^{-1} \alpha_K^t \beta_K \bar{m} \quad (20)$$

$$\text{where } \bar{m} = (\beta_H^t \beta_H)^{-1} \beta_H^t (\bar{S}_H - \alpha_H \bar{I}_0) \quad (21)$$

For ships equipped with external self-ranging, the hull sensors are not needed. Ranging without

currents gives a vector signature  $\vec{S} = \beta \vec{m}$  and the currents to degauss are calculated with a preprocessed control matrix, G:

$$\vec{I} = -(\alpha^t \alpha)^{-1} \alpha^t \beta (\beta^t \beta)^{-1} \beta^t \vec{S}_0 \quad (22)$$

or 
$$\vec{I} = -(\alpha^t \alpha)^{-1} \alpha^t \vec{S}_0 = -G \vec{S}_0$$

when  $\alpha = \beta$ . Magnetic signatures, no matter how complex or unstable, can be zeroed within environmental noise level by feedback degaussing.

I am indebted to Dr. Bruce Hood, Ms. Paula Zivi and Mr. Kim Watts of the Naval Surface Warfare Center, Carderock, Maryland, for their continued support and collaboration over the last two decades.

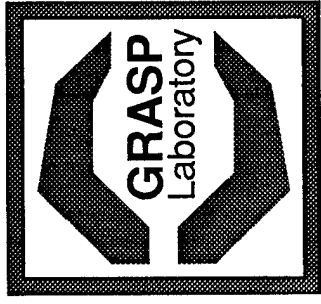
#### Bibliography

1. **Introduction to Electrodynamics** by David J. Griffiths, chapter 4, Prentice Hall (1981)
2. **Ferromagnetism** by Richard M. Bozorth, chapters 11,13 and 19, D. Van Nostrand, (1951)
3. William F. Brown, Jr., Phys. Rev. **75**, 147 (1949)
4. U.S. Patent number 5,189,590 by Carl S. Schneider (1993)

# **Sensors and Sensory Fusion for Minefield Surveillance and Reconnaissance**

**Dr. Ruzena Bajcsy and Max Mintz**  
GRASP Laboratory  
Dept. of Computer and Information Science  
University of Pennsylvania

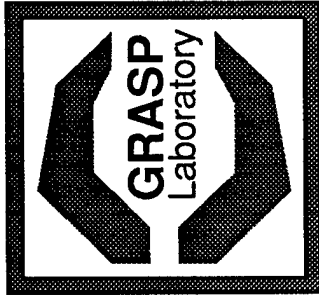
It is well known that the task of mine detection is extremely complex because of the various materials mines can be made of, and because of the various environments in which they can be found. Hence, there is no single technique that can solve the "mine problem." Multiple sensing modalities vary with regard to the type of physical principles involved and must be distributed over space. This implies several research issues, amongst them: modeling the physical and geometric characteristics of the sensors, selecting the best sensors at the appropriate time for a given environment, and, finally, fusing and/or integrating the data into a coherent common framework. In this paper, the authors discuss sensor modeling, spatial distribution, and integration. Examples of visual and ultrasound sensors will be used to demonstrate the principles involved. Research supported by Army, DARPA and NSF grants.



# *The Problem*

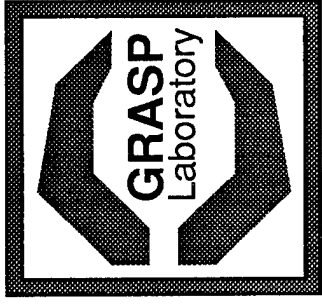
---

- The goal of this program is to demonstrate technologies for detection and clearance of land mines and near-surface unexploded ordnance (UXO).
- Highest priority is given to "a clandestine surveillance, reconnaissance and detection capability that uses a variety of systems to provide knowledge of the full dimensions of the mine threat without exposing the reconnaissance platforms."



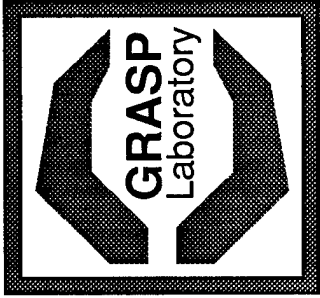
## *Our Vision*

- Develop a comprehensive, flexible set of heterogeneous distributed robots with sensing capabilities that can autonomously or semi-autonomously navigate different environments in a coordinated fashion.
- These robots will communicate with a human monitor while searching for and detecting mines/UXO in a given area.
- The different sensing modalities will require a theory of sensory fusion.



## *Our Vision*

- We our especially concerned with:
  - Sensing modalities of the terrain, mines and trip wires.
  - Developing a comprehensive theory of sensory *fusion*.
  - Theory *validation* using a satisfactory physical testbed.
- Sensing can be further divided into:
  - Modeling sensors, including different physical principles.
  - Experimental measurements, data analysis, and classification of terrain, mines and wires.

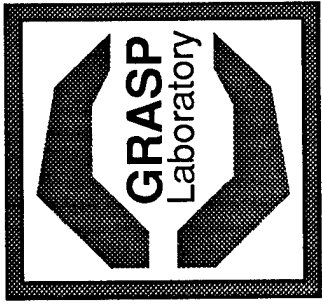


## *Our Vision*

---

- Sensory terrain measurement provides spectral estimates corresponding to:
  - Chemicals in the terrain.
  - Spatial distribution of surface texture.
- Sensing provides two pieces of information:
  - Material properties of the mine.
  - Geometry of the mines and/or trip wires depending on the material.

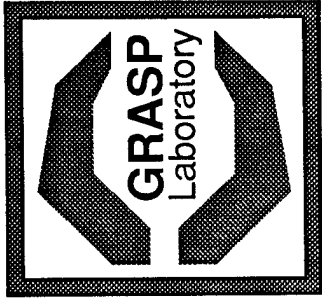




## *Our Vision*

---

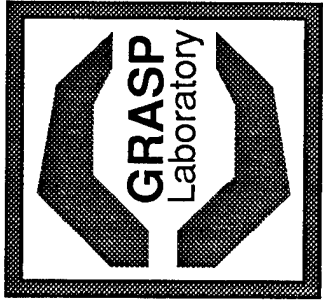
- Since inferences based on single sensory modalities are less reliable than inferences based on multiple nonhomogeneous sensors, make use of all available sensors.
- Measurements obtained during mine detection process are a mixture of true responses due to mines and/or trip wires and the terrain.
- The challenge is modeling this mixture to effectively separate terrain signatures from mine/trip wire.



## *Requirements for Sensors of Anti-Personnel Mines*

---

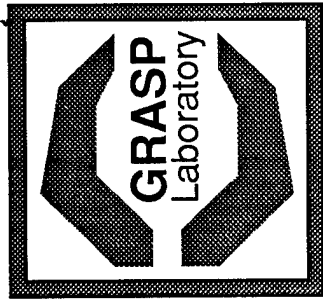
- Compact and small size (less than 5kg).
- Low power consumption (less than 2W).
- Simple interface and local preprocessing.
- Low cost (less than \$500).
- Reliability above 98%.
- False alarms below 20%.
- Response time 0.1 second.
- Easy to maintain.



# Three Categories of Mines

---

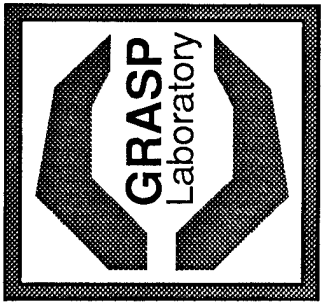
- **Anti-tank mines**
  - Require ground pressure of 150-300 kg.
- **Anti-personnel mines**
  - Frequently triggered by wire and lethal within 30m radius.
- **Blast anti-personnel mines**
  - Typically have a small diameter (10cm), triggered by ground pressure of 10kg/dm<sup>2</sup>.



# *Examples of Mines and How to Model Them*

---

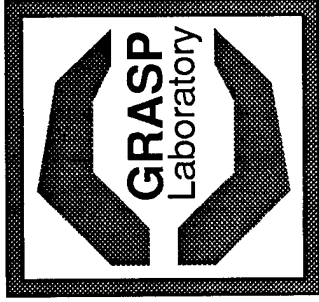
- Following the examples of mines as presented in the open literature, e.g.:
  - P. Machler. Detection technologies for anti-personnel mines. Proc. Autonomous Vehicles in Mine Countermeasures Symposium, April 4-7 1995, Naval Postgraduate School, Monterey, CA, pp. 6.150-6.154.



# *Sensor-Based Mine Detection and Localization*

---

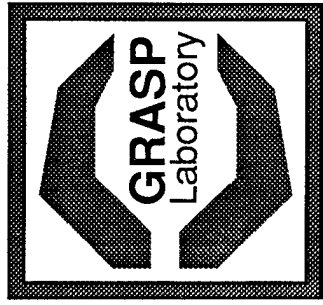
- We envision a sensory fusion system flexible enough to accommodate existing sensors *and* information obtained from other sources.



# *Sensor-Based Mine Detection and Localization*

---

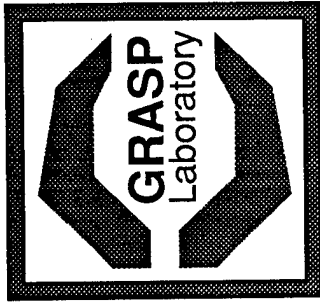
- Our methodology provides a fixed-size set-valued estimate of the target's position and a guaranteed lower bound on the probability of capturing the target in the set.
- Our method provides a basis for adjusting or setting system design parameters, e.g.:
  - Uncertainty limits on sensor noise.
  - Size of the required confidence set.
  - Time period/size of spatial domain over which sensor data is collected to achieve given probability of capture.



# *Sensor-Based Mine Detection and Localization*

---

- We suggest a coarse-to-fine approach whereby the system employs sensors with coarse resolution to detect likely regions where mines are situated may succeed.
- The coarse region can be searched for mines with a target position sensor system with finer resolution.



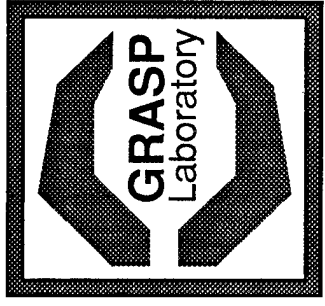
# *Sensor-Based Mine Detection and Localization*

---

- **Requirements**

- Coordinated use of multiple non-homogeneous sensors.
- Efficient procedures for determining effective deployments strategies of these sensors.
- Algorithms for combining data from multi-resolution sensors which:
  - » Achieve mine detection and localization with given probabilistic performance guarantees.
  - » Operate under conditions which include uncertainties in sensor location and the physical conditions beneath the mine field surface.

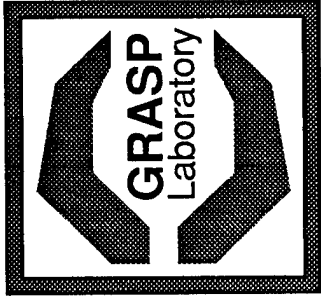




# *Examples of Mines and How to Model Them*

---

- Recent anti-personnel mines have no metal.
  - At best, the needle of the fuse is metal.
  - The package is made of wood and/or plastic.
- The only sure thing is the presence of explosives, e.g. TNT, RDX, PET.
- There are approximately 2000 different types of mines for which catalogs exist.



# *Error Models for Sensors*

---

- We have developed uncertainty models and error characterization for CCD cameras.
- This research, though performed only on video cameras, is generalizable to any noncontact sensor since it models:
  - Geometry of the optics and sensory chip.
  - Physical characteristics, such as photon conversion, charge collection, charge transfer and signal measurement, which includes the digitization error and interface error to the proper computer.

# The Video Sensor

3D real scene  $\longrightarrow$  2D digital image:  
*continuous*  $\longrightarrow$  *spatially and intensity discrete*  
*plus systematic and random noise*

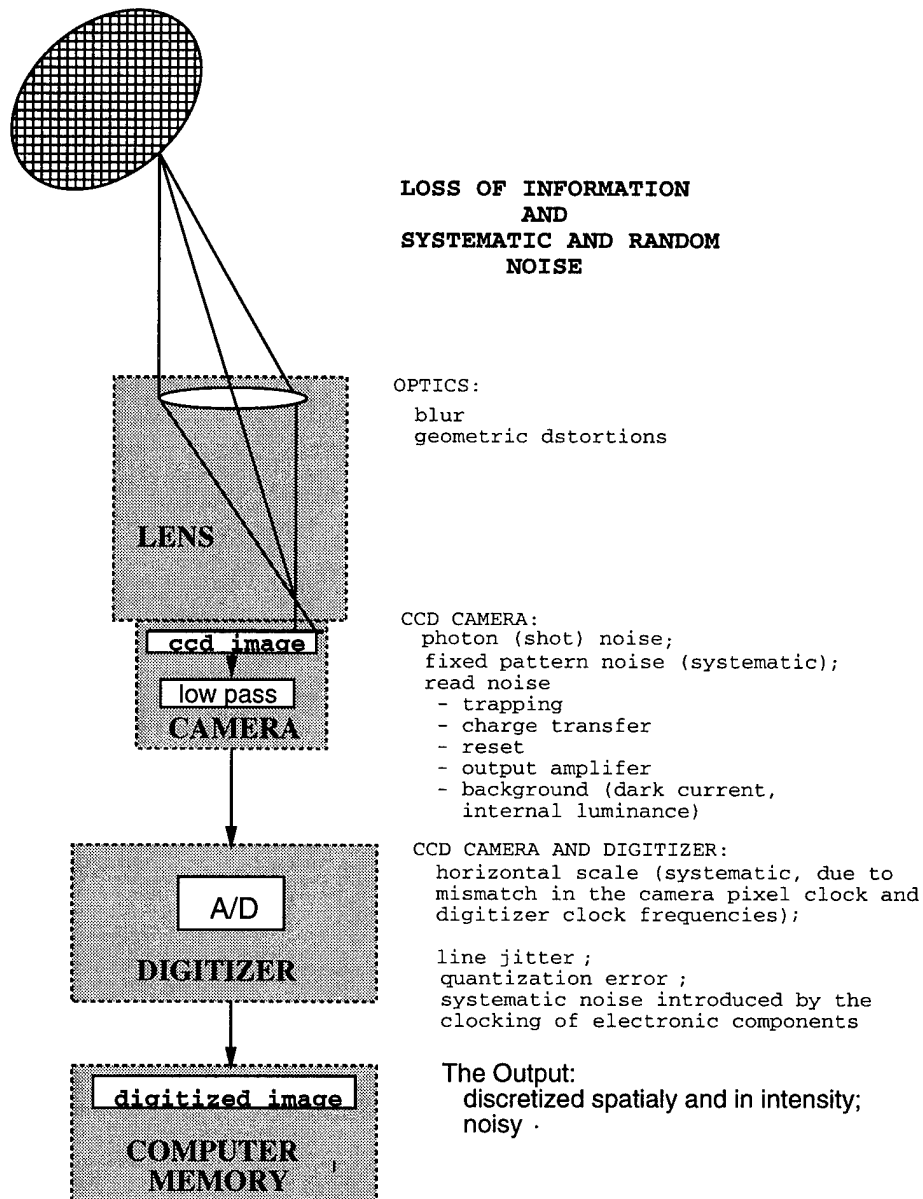


Figure 1: The imaging system: *in* – incoming light from a scene; *out* – a digitized image

# The Imaging Array – CCD camera

## Two charge transfer organizations

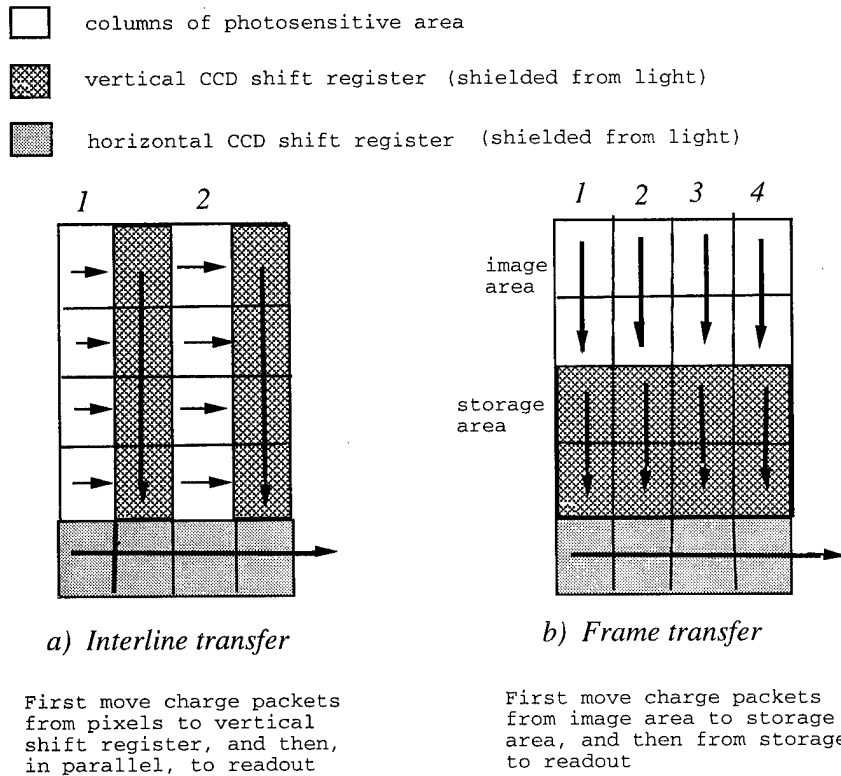


Figure 2: Two charge transfer organizations

# The Video Sensor

## Parameters and factors characterizing it:

- Intrinsic to the CCD camera:  
*quantum efficiency, charge transfer efficiency (CTE), read noise, spatial resolution, temporal resolution, and derivative of these – intensity resolution.*  
Read noise, in particular, is our concern.
- Related to the joint work of CCD camera and digitizer:  
*systematic background noise component, horizontal scale and line jitter.*
- Related to the optical system:  
*depth of field, point spread function of the lens, geometric distortions.*
- Related to the continuous to discrete signal conversion and subsequent discrete signal processing: spatial and intensity resolution of the digital image, and geometric and numeric computation precision and accuracy.

## CCD camera noise

- *Photon (shot) noise* — random fluctuations in the photon flux. Poisson distributed.  
Dominates the total noise at mid and high intensity levels.
- *Read noise* — related to the CCD operation (charge collection, charge transfers, and signal measurement).  
Random noise most difficult to control.  
Most prominent at low signal levels.
- *Fixed pattern noise* — random noise related to impurities and defects in the semiconductor.  
Controlled via *flat field* calibration.

## Read noise components

- *Background noise*
  - *dark current* (thermal);
  - *luminance* (induced by the on-chip electronic).

A *systematic* noise, due to the clocking of digitizer and other electronic components, is added to the camera background noise and results in the *background noise of the digital image*

- *Charge transfer noise*
- *Output amplifier noise*

## Manifestation of the background noise in the *dark images*.

**Camera/Digitizer configuration: SONY XC-77RR/DT1451**

- CCD Camera: SONY, XC-77RR  
rectangular array of 493(V)×768(H),  
sel size:  $11 \times 13\mu m$ , chip size  $10.0 \times 8.2mm$ ,  
pixel clock frequency  $14.318MHz$ , within 1% error;
- Frame grabber: DT1451  
effective digitized image size 480(V)×512(H) pixels,  
digitizer clock frequency *about*  $10MHz$ .

# Dark images and the background noise

Observe: systematic error, dark current noise, internal luminance, charge transfer loss

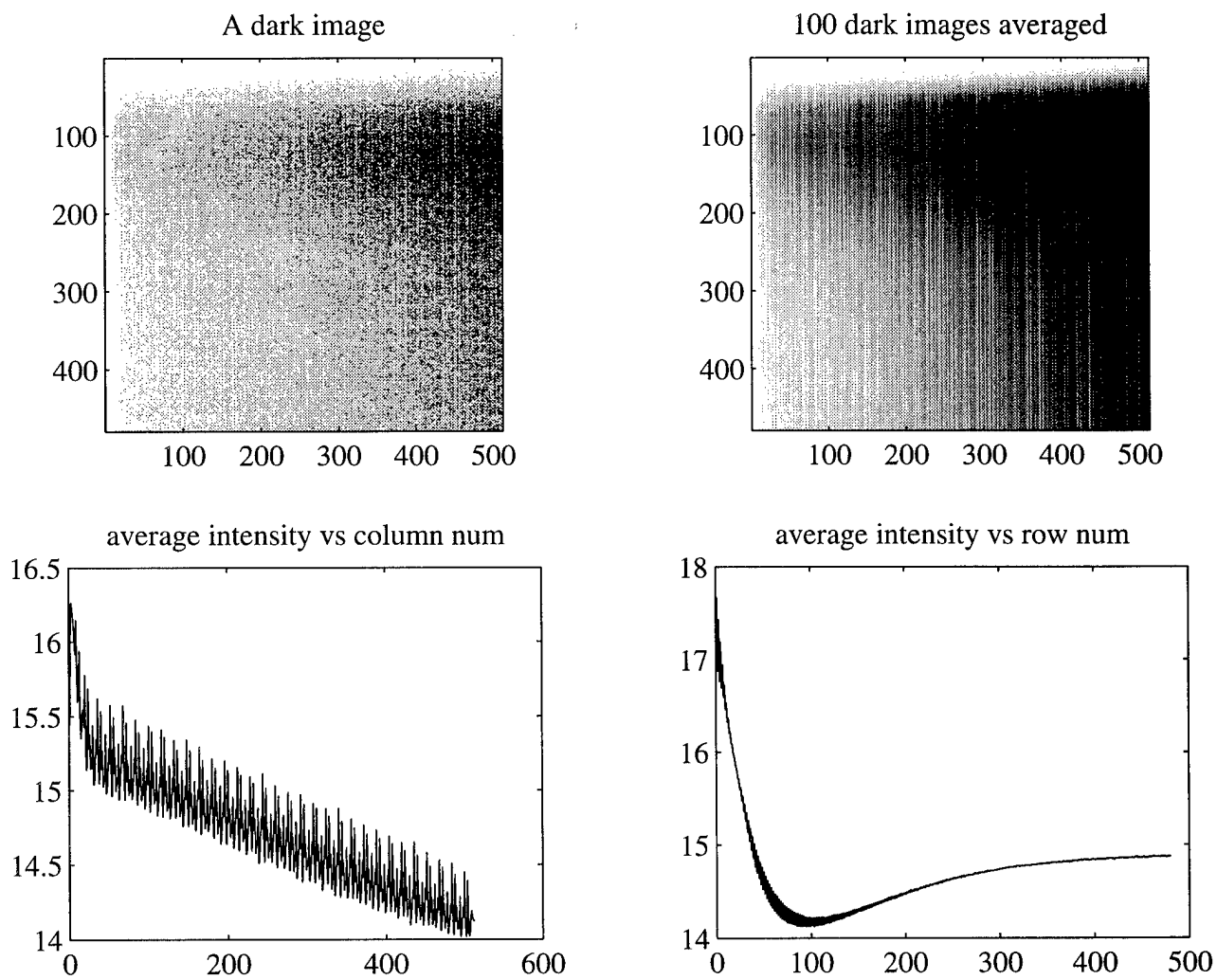


Figure 3: The images in top row are enhanced prior to display. The graphs show average intensity by column and by row for the image obtained by averaging the 100 dark images.



# "Dark image" signatures for different video sensors

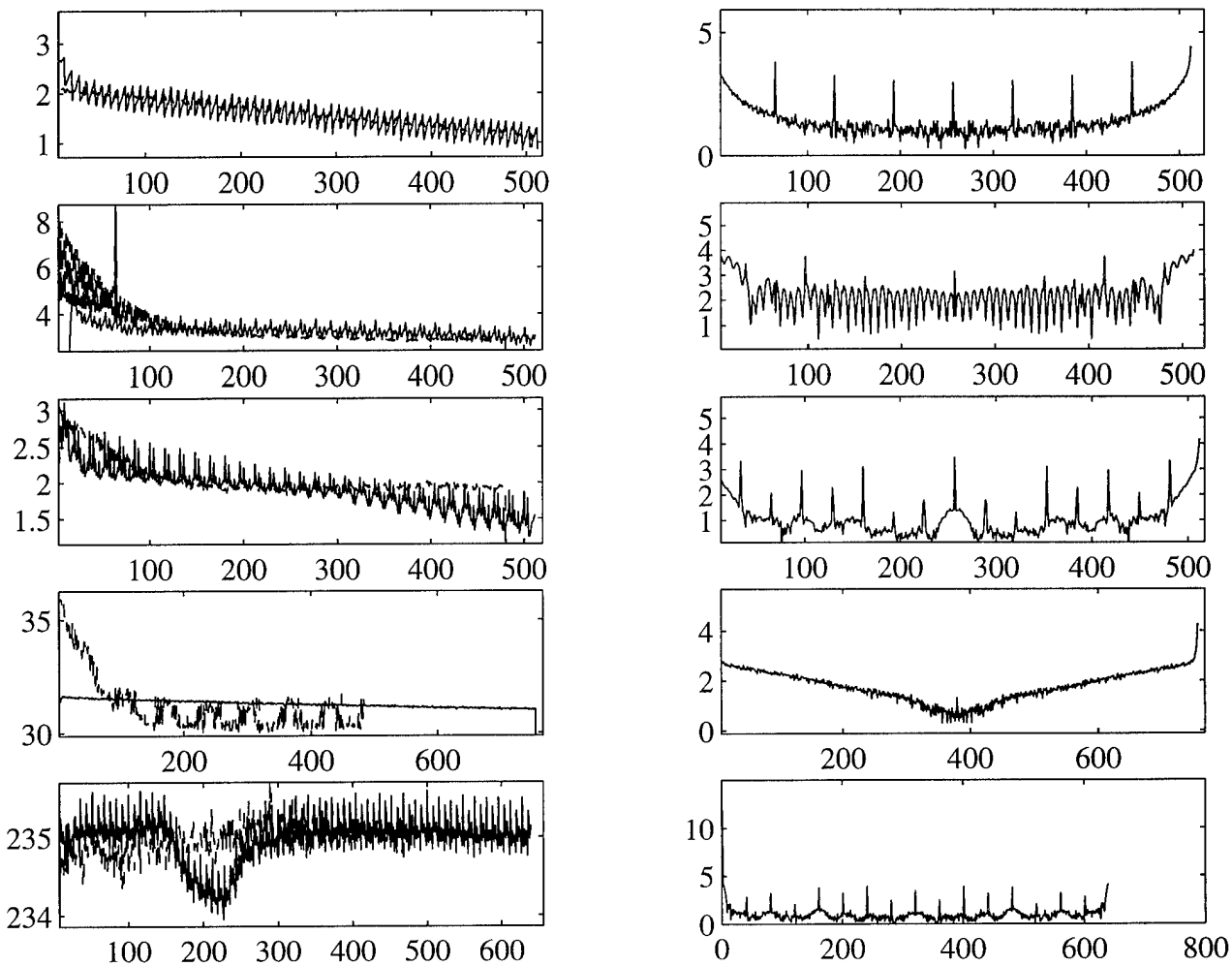


Figure 4: Left plots show mean intensity by rows and columns in dark images, and the corresponding right plots show the power spectrum for the signal obtained by averaging all columns in the corresponding dark image

## Observe

- variations in the average intensity
- periodicity in horizontal direction
- exponential decline in average intensity in rows in the top part of the image
- decline in average intensity in columns going left to right

# Residual images

When over exposed, an image is “remembered” on the chip for hours: quantum efficiency is raised artificially

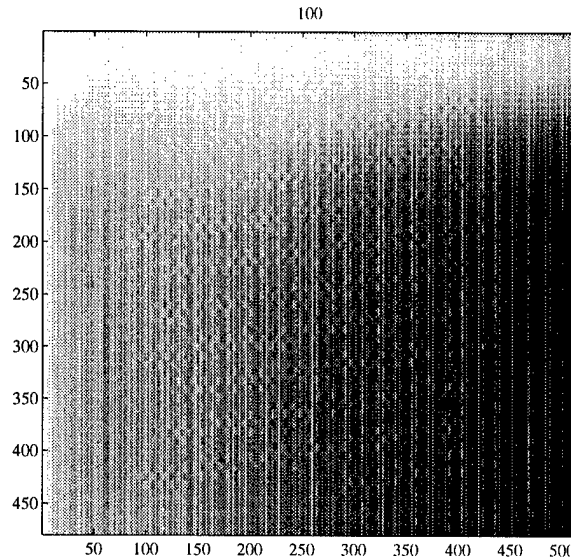


Figure 5: 100 dark images after exposing the camera to a checker board pattern

**It is important to pay attention not only to the proper use of the cameras during current use, but also how they were used previously.**

# Flat fields and nonuniformity in pixel response

*Flat field* is the response of the video sensor to uniform stimuli

- *Flat-field correction*: correcting for background noise, systematic errors and response nonuniformities via

$$I_{corrected} = \frac{I - D}{F - D} * m$$

where

$I$  is the uncorrected image,

$D$  is an average dark image,

$F$  is an average flat field image for fixed illumination,

$m$  is the overall average intensity of  $F - D$ .

The image difference and division are pixel-wise operations.

Test I: correction with flat field *approximation* obtained with lens on and diffusing glass. Two images (different cameras, same digitizer) are independently corrected.

- Image pairs

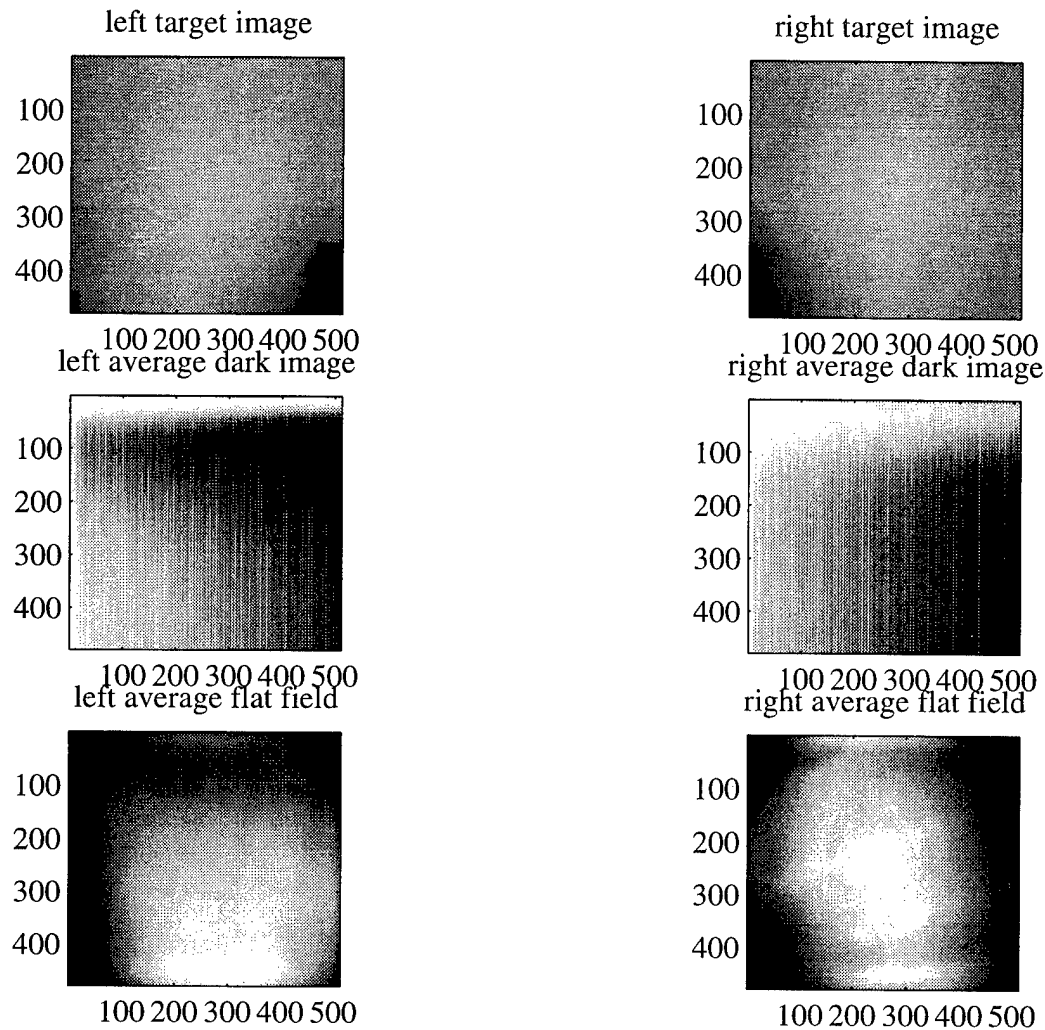


Figure 6: 3 pairs of images: target, dark, flat field approximations

# • Histograms of the image pairs

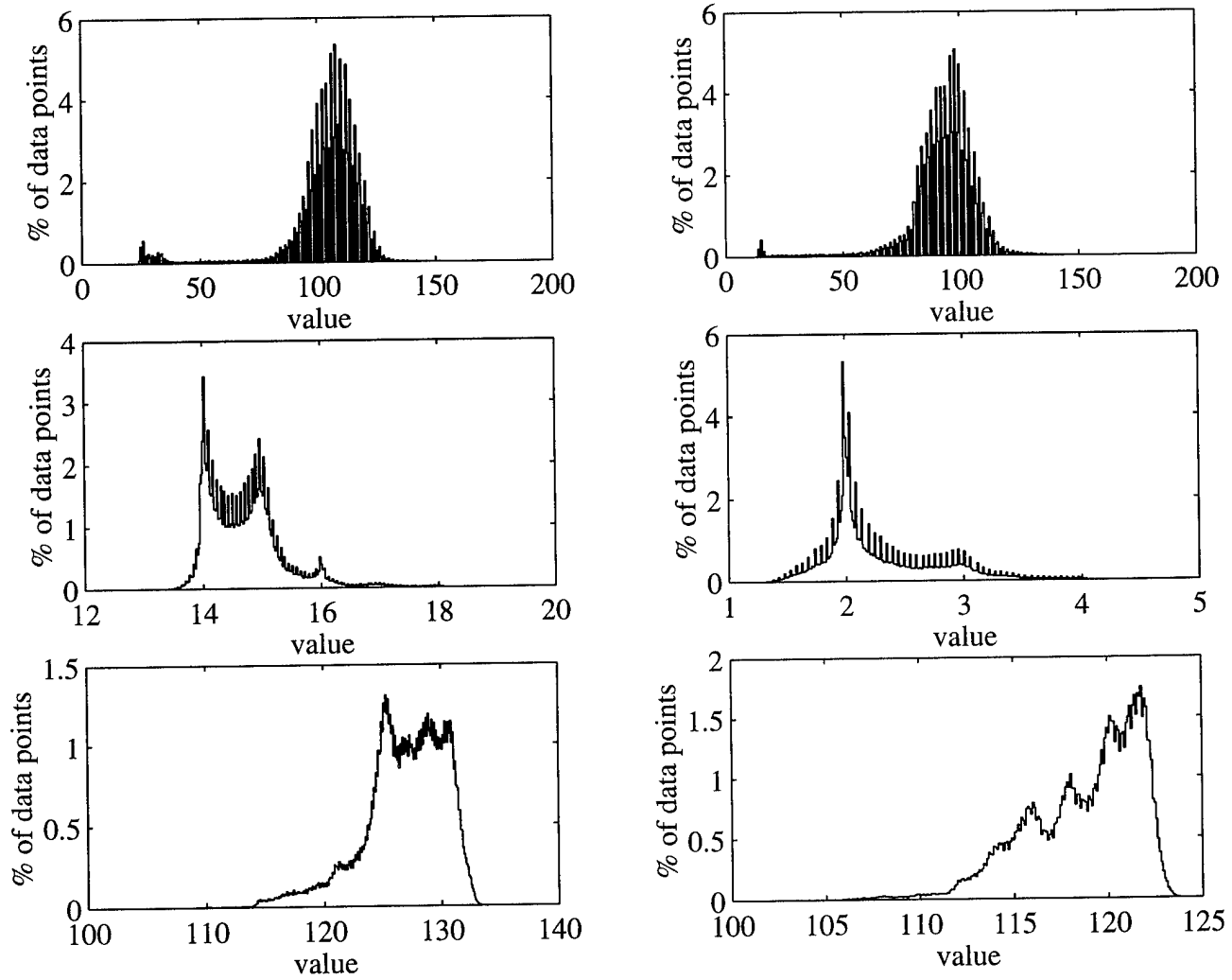


Figure 7: Histograms. Top to bottom: raw, dark, flat field approximation images

- Comparison of original targets and corrected images

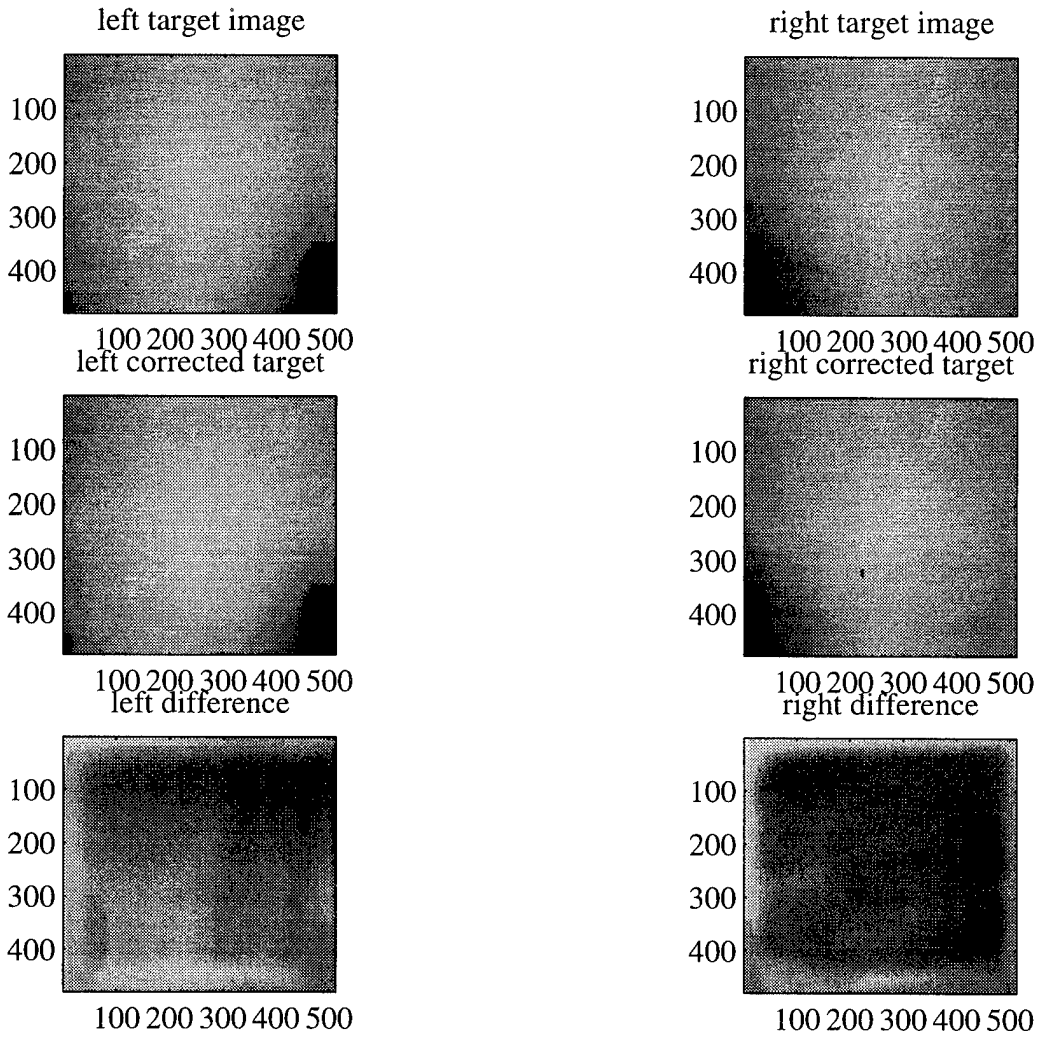


Figure 8: Top to bottom: original, corrected, and difference between the two

- Histograms of original targets and corrected images

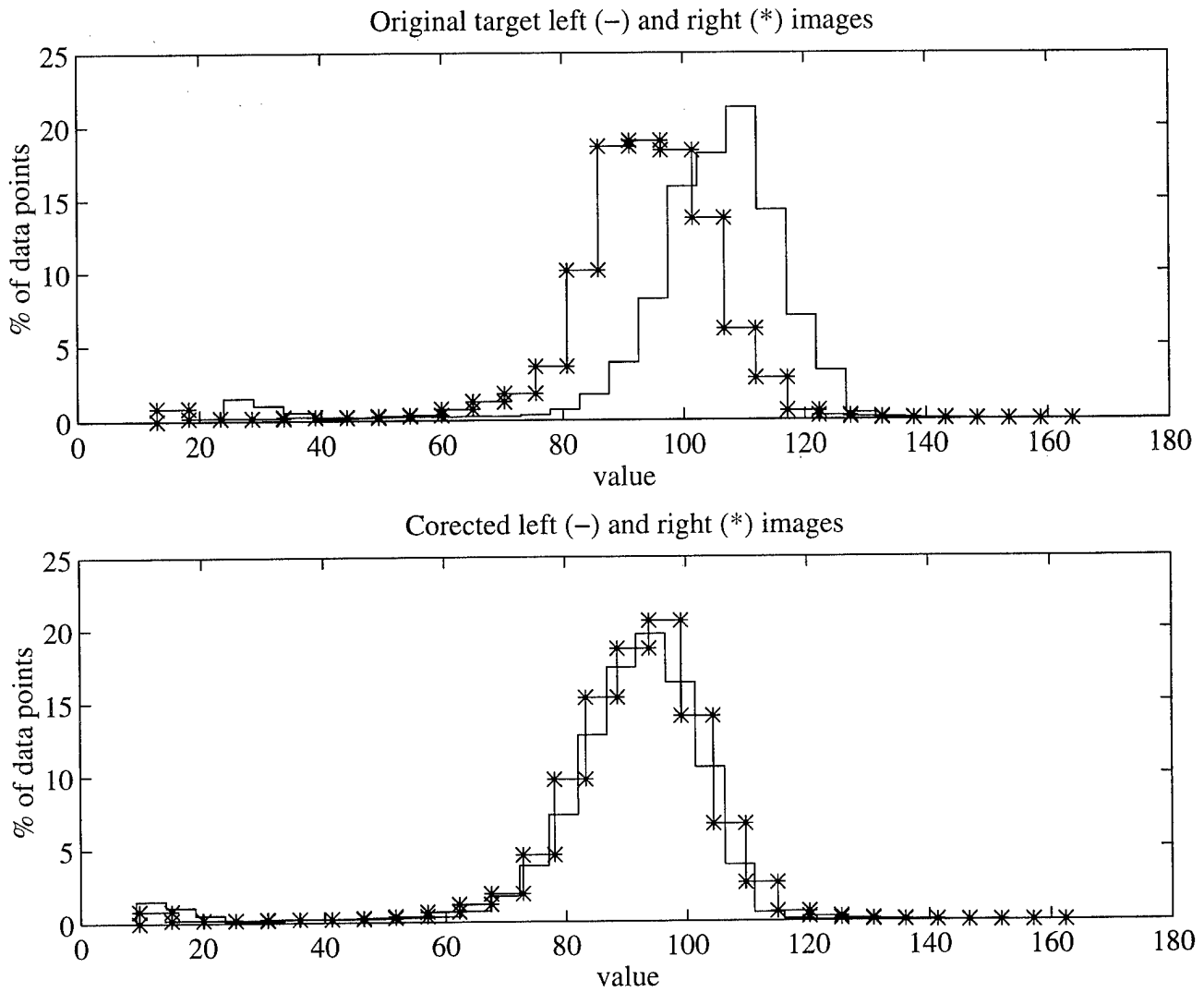


Figure 9: Top to bottom: original targets and flat field corrected images

# Radiometric calibration

**Preliminary results indicating the importance of the radiometric calibration in the multiple camera applications**

**Test II: disparity map computation for “uniform reflectance white card” .**

**Flat fields are obtained without the lens and with a diffusing glass.**



- Stereo pair, flat field pairs at avg level 220, flat field corrected stereo pair.

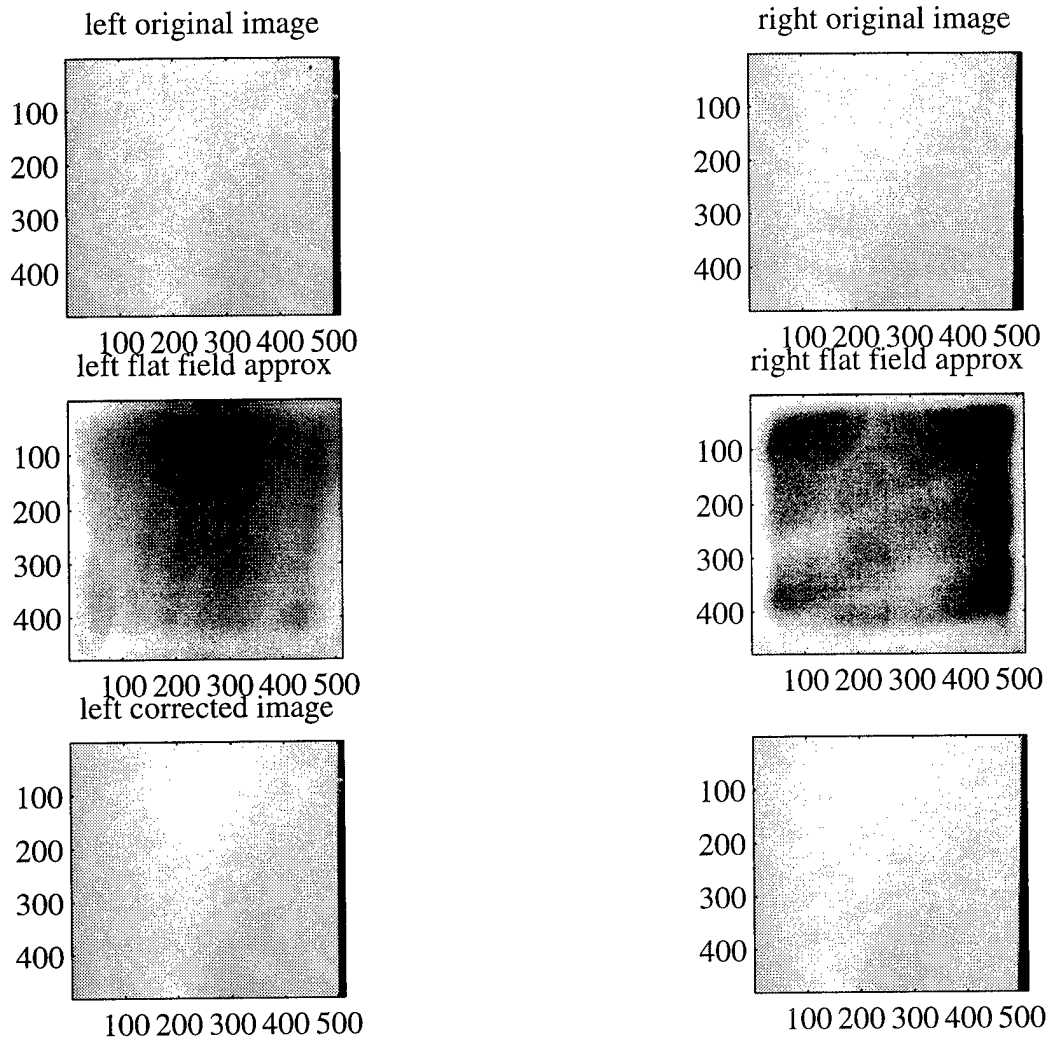
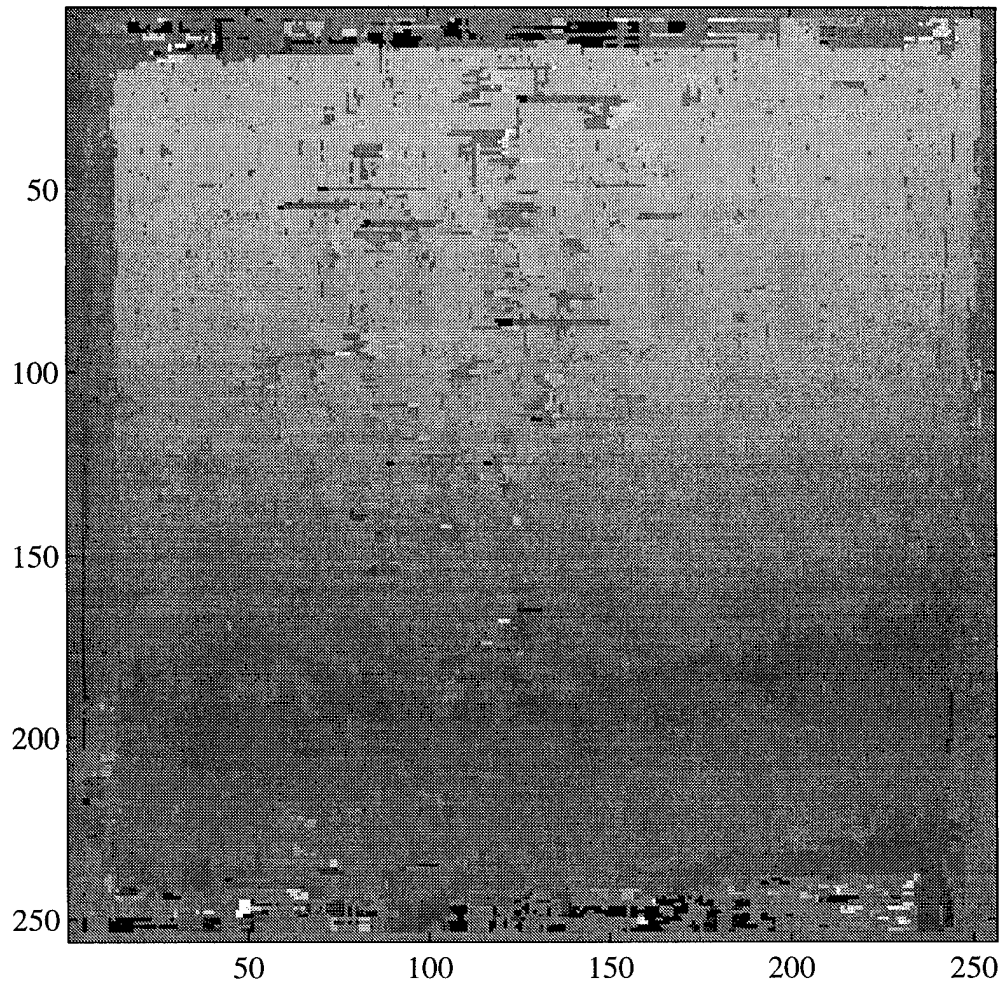


Figure 10: Top to bottom: original stereo pair, flat field pair, flat field corrected pair

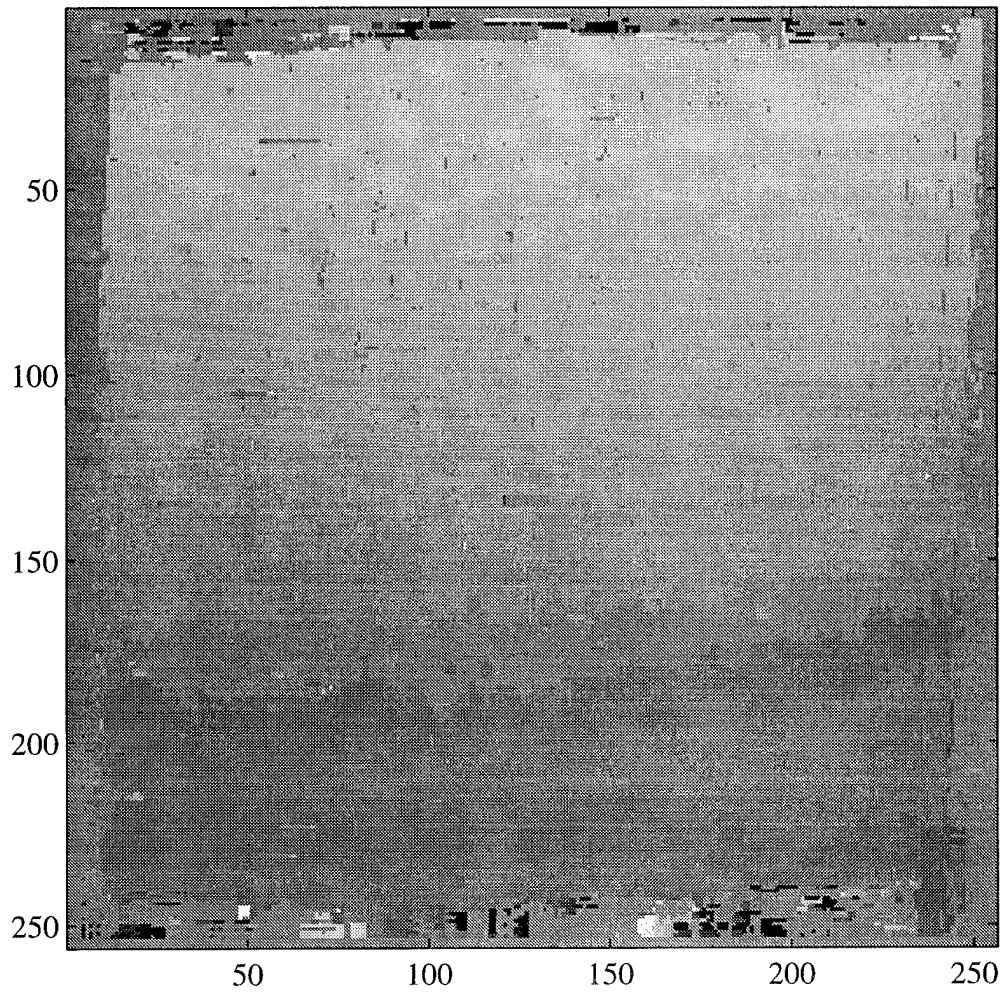
- Disparity map based on uncorrected stereo pair, tuned.

subpixel dmap uncorrected, with tuning

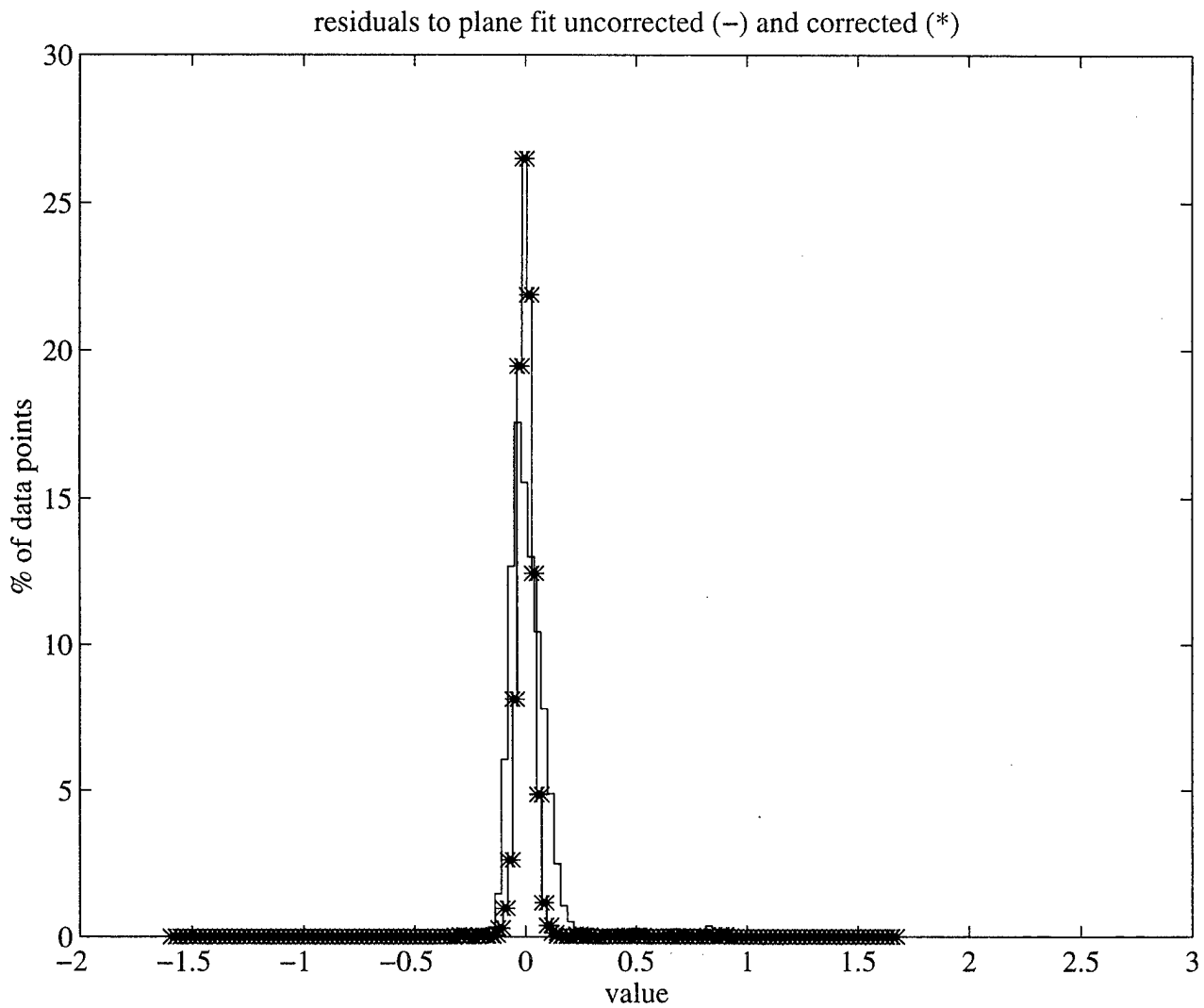


- Disparity map based on corrected stereo pair, no tuning.

subpixel dmap corrected, no tuning, flat field avg level 220

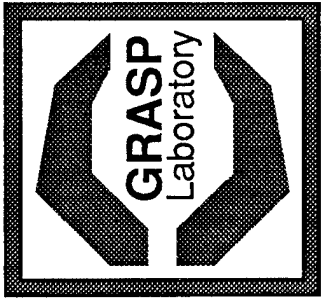


- Comparison of the residuals of a plane fit to the uncorrected and corrected subpixel disparity maps



$$STD(resid_{uncorrected}) = 0.1668$$

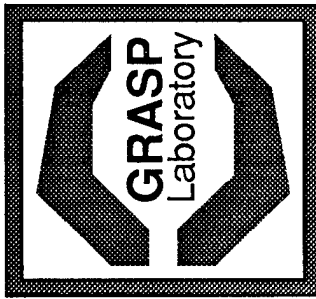
$$STD(resid_{corrected}) = 0.0679$$



# *Materials and Their Salient Attributes*

---

- One can obtain the salient attributes of the terrain with a suite of sensors.
- Hence, one can perform the desired classification of the soils.

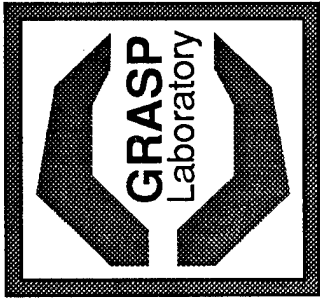


# Materials and Their Salient Attributes

CLASSES OF MATERIALS

ATTRIBUTES	CLASSES OF MATERIALS							
	Metals	Rocks Concrete	Glass Ceramics	Rubber Polymers	Wood	Soil Sand	Pebbles Gravel	Viscous Mixtures
Penetrability	No	No	No	No	No	Yes	Yes	Yes
Deformability	Yes	No	No	Yes	No	Yes	Yes	Yes
Hardness	Yes	Yes	Yes	Yes	Yes	No	No	No
Compressibility	No	No	No	No	No	Yes	Yes	No
Surface Roughness	Yes	Yes	Yes	Yes	Yes	Yes	Yes	No
Brittleness	No	Yes	Yes	No	No	No	No	No
Thermal Conductivity	Yes	No	Yes	No	No	No	No	No
Electrical Conductivity	Yes	No	Yes	No	No	No	No	No
Magnetic Permeability	Yes	No	Yes	No	No	No	No	No
Optical Properties	Yes	No	Yes	No	No	No	No	No
Viscosity	No	No	No	No	No	Yes	Yes	Yes

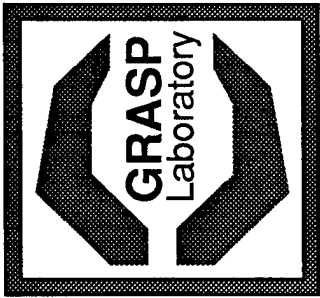
- P.R. Sinha, *Robotic Exploration of Surfaces and Its Application to Legged Locomotion*, Ph.D. thesis, Dept. of Mechanical Engineering and Applied Mechanics, University of Pennsylvania, Philadelphia, PA Feb. 1992.



## *Soil Models*

---

- There is vast knowledge of soil mechanics.
- The material science of soils is also well understood.
- The spectral, optical and chemical properties of soils are well documented in Joseph Bowles, *Engineering Properties of Soils and Their Measurement*, McGraw-Hill, 1970.



# *Demonstrations*

---

- **Demonstrations are to be carried out under field conditions with:**
  - Sufficient sensitivity to permit high detection rates and localization of the threat.
  - Sufficient confirmation to distinguish mines/UXO from clutter.





# **The Use of Ocean Optical Data to Predict the Performance of Mine Detecting Ocean Lidar Systems**

**R. Norris Keeler**  
Kaman Diversified Technologies Corp.

## **ABSTRACT**

In the course of conducting operations in littoral waters it is important for operational commanders to assess what performance they may expect from various fleet assets. Since ocean lidar mine detection systems are new additions to the US Navy, only recently has serious consideration been given to how existing oceanographic data can be used as input to lidar simulation codes for mine detection performance. While measurements of the diffuse attenuation coefficient from the CZSZ sensor by *in situ* instruments provides the most applicable input to predictive codes, by far the most prevalent data available is seasonal Secchi disc data. Using the relationship between Secchi depth and extinction coefficient "c", reasonable estimates of c can be made from available Secchi data. The extinction coefficient is relevant to the performance of "spot" type lidars; the absorption coefficient and the diffuse attenuation coefficient relate to broad area imaging lidar systems. The probability of detection and false alarm rate can be estimated for a given ocean lidar system when these oceanographic properties are known, along with the sea state.

## **BACKGROUND**

The performance of an ocean lidar mine detection (and bathymetric) system depends on the quality of the sea water; the sea state, and for bottomed mines, the relative albedo between the mine and the ocean (or surf zone) bottom. Ocean optical data is generally available, although not normally on a real-time basis; and sea state can be obtained from estimated wind velocity in real time. Data on the albedo of the ocean bottom is often available, particularly in well traveled littoral regions. Let us first consider the data pertaining to ocean turbidity.

## OCEAN OPTICAL DATA

There are a number of ocean optical data sources available at this time. The best known of these is the Coastal Secchi Depth Atlas<sup>1</sup>. This gives seasonal tables of Secchi depths throughout the world's oceans. The validity of these data and their interpretation will be discussed later. Various Secchi depth tables exist<sup>2,3,4</sup>, and are currently available. Much of this activity was initially carried out at the Naval Postgraduate School, and now resides principally at NRL Stennis.

With the advent of massive computer capability and global information systems, incredible amounts of real time data are now available to the operators. The first example of such data was the CZCS (Coastal Zone Color Scanner) which was launched on the Nimbus-7 satellite in October, 1978. This data was available until 1986, when the CZCS failed, operating well past its projected lifetime of one year. Its replacement will be the satellite borne WIFS (operating in the visible range of the spectrum), which will be fielded shortly.

The Ocean Color Section at NRL Stennis is a part of the Remote Sensing Applications Branch at the Stennis Space Center Detachment of the Naval Research Laboratory. The section optical processes and patterns using satellite and airborne sensors that record data primarily in the visible portion of the optical spectrum (ocean color). They have concentrated in the interpretation of the CZCS data. The section makes extensive use of web sites to make their data available<sup>5</sup>.

In conjunction with various lidar deployments, personnel from APL Johns Hopkins, Sequoia Scientific (formerly SRI), CSS and NRAD have carried out *in situ* measurements of various ocean optical properties, and these groups remain active in developing or encouraging the development of *in situ* measuring equipment<sup>6,7,8</sup>.

## SECCHI DISC DATA

The most comprehensive description of the use of the Secchi disc is given by Preisendorfer<sup>9</sup>. It is appropriate, however, that the present work be presented at the Naval Postgraduate School, because it was at NPS that the first concerted effort was made by Oceanography Professor Stephen P. Tucker to tabulate and interpret the Secchi data available and put it into a form which could be used to predict the

performance of military systems<sup>10,11,12,13</sup>. In this paper we will be dealing with the performance of lidar mine detection systems, only recently tested, evaluated and deployed in the fleet for the first time<sup>9</sup>. The performance of bathymetric lidar systems such as SHOALS and LADS is normally limited to riverine waters where Secchi data is difficult to interpret<sup>14,15</sup>, and these systems will not be discussed here.

Historically, the Secchi disc in its present form was invented and deployed by Italian scientists in the 1865-66 time frame. This work has been translated<sup>16</sup>, and the physics behind the disc measurement has been described by Preisendorfer<sup>17</sup>. It is by far the most commonly used ocean optical measurement device.

Physically, the disc is a circular white target 30 cm in diameter, with a 50 pound weight attached. Discs of this type were first used by Kotzebue in the early 19th century, but these procedures were not systematized until the work of Secchi and Chialdi in 1865. The procedure was to lower the disc until it was no longer visible; this depth was  $Z_{s1}$ ; then, the disc was raised until it again became visible. This depth was called  $Z_{s2}$ . The Secchi depth was then calculated by:

$$(1) \quad z_s = \frac{z_{s1} - z_{s2}}{2}$$

The most comprehensive work on standardization was published by Gershun<sup>18</sup>.

This measurement is subject to many sources of error. For example, with surface glint and other conditions of variable illumination, the eye's contrast sensitivity falls, decreasing  $Z$  by about 20%. Viewing the disc from the sunny, rather than the shady side of the boat reduces  $Z$  by 20%, viewing the disc in rough seas reduces  $Z$  by ~ 30%. Use of a box with a glass bottom has eliminated these effects. The intrinsic error in the measurement under optimum viewing conditions is ~ 2-3 feet. This gives one an idea of the possible errors in the data which is used to create a Secchi Atlas. In the measurements reported in this paper, semiquantitative estimates of the magnitude of these effects were obtained.

It should be noted that among all the instrumentation now existing such as spectrophotometers, bolometers, vibrating reed electrometers, not to speak of the humble Simpson Meter, the Secchi measurement is now the only widely used measurement technique which relies solely on the human eye.

Attempts have been made to model the dependence of  $Z$  on  $K_a$  in a linear way. These attempts have not been entirely successful, although for the majority of waters, fair approximations can be made. It was the custom of the various Soviet investigators involved in the field to take the Secchi Disc data available, and try to fit them to the simple relationship:

$$(2) \quad z_s = \frac{\beta}{\epsilon}$$

with  $\beta$  the coupling coefficient, and with  $\epsilon$  the extinction coefficient, given by:

$$(3) \quad \epsilon = K_a + K_s, \text{ or, } c = a + b$$

Equation (3) is written in two forms. The second form is more commonly found in US usage. This equation states that the extinction coefficient is equal to the sum of the absorption coefficient and the scattering coefficient. Equation (2) has been rigorously derived by Levin<sup>19</sup> and Preisendorfer<sup>20</sup>. Levin also considered the effect of enhanced backscatter on the Secchi depth measurement in this paper. It should also be noted that Tyler earlier derived a relationship for the disc which was incorrect<sup>21</sup> although this particular reference does contain useful and interesting data on the relationship between the quantities  $c$  and  $a$ .

The coupling coefficient,  $\beta$  is a "constant" which is related to the conditions under which the Secchi measurements are made. It is given by:

$$(3) \quad \beta = \ln \left\{ \frac{\tau C_0}{C_T} \right\}$$

This relationship was derived by Blackwell<sup>22</sup>. Here,  $\tau$  is the product of the still water contrast transmittance factor and the time averaged transmittance factor related to wave

generated refractive effects at the water surface. If Secchi measurements are made over still water, with an umbrella or awning obstructing sunlight, then  $\tau = 1$ . Secchi himself realized this and attempted to obtain ideal experimental conditions in his work.  $C_0$  is the inherent contrast of the disc at the given depth, and is simply equal to:

$$(4) \quad C_0 = \frac{R - R_\infty}{R_\infty}$$

where  $R$  is the submerged reflectance of the disc and  $R_\infty$  is the total backscattering from the infinite water column as viewed by the observer. Note here that the light source is the sun.  $C_T$  is the threshold contrast, and is based on the physiological optics of the eye; specifically the adaptation luminance of the eye, and the angular diameter of the Secchi disc. This has recently been treated in detail by Wyzecki and Stiles<sup>23</sup>.

Fortunately, the coupling coefficient has a logarithmic dependence on the transmission coefficients and the threshold contrast. The values for  $\beta$  vary between 5 and 6 for the waters in which we normally operate<sup>18,24</sup>. Some Soviet investigators obtained somewhat higher values<sup>4</sup>, probably because their survey included more data taken in littoral and riverine waters. Second order correction can be applied, but are beyond the scope of this paper.

Since scattering and absorption are caused by suspended particulate matter (biologics), it has been argued that there should be some rough relationship between  $K_a$  and  $K_s$ . But there is not always a direct relationship between  $K_a$  and  $K_s$ . Consider Figure 1. This is a plot of  $K_s$  vs.  $K_a$ . Both these quantities are mean values, with the limiting curve representing the lowest  $K_a$  for a given  $K_s$ . These are the appropriate values, by the way, for lidar imaging codes. The Red Sea actually has a red absorbing component. Other points off the curve are associated with upwelling areas off the West Coast of continents. But in general, Figure 1 can be used as a guideline. The solid curve represents varying concentrations of phytoplankton, and at its lower extremity, the properties of pure water. Off curve points indicate excess absorption due to other biomass matter such as gelbstoff<sup>25</sup>. The waters for which the data are shown are waters which might be encountered in the lower and middle Persian Gulf, AUTEK, Panama City, Adriatic, Korea, etc. The wavelength is 485 nm, which is appropriate for Secchi measurements in the ocean, as the eye

selects out the optimum wavelength in the course of the measurements.

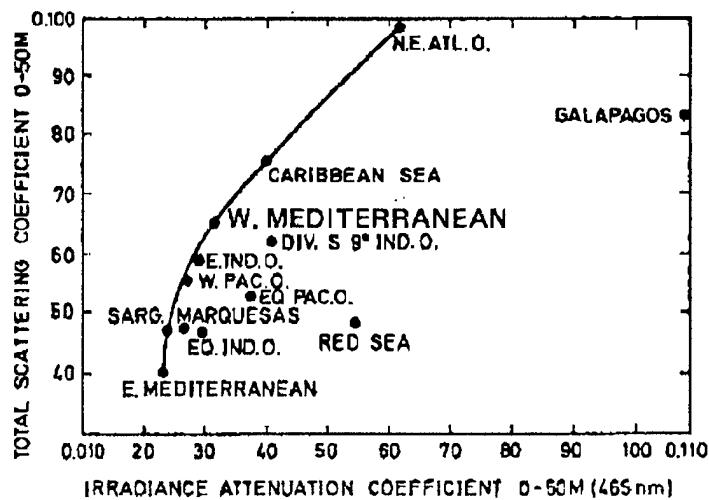


Figure 1

Since the purpose of this paper is to outline how various ocean optical data can be used to predict ocean lidar performance, we must now turn to the hydro-optic codes used to predict lidar performance<sup>26,27,28</sup>. These codes require certain inputs which they then use to calculate signal to noise, probability of detection and false alarm rate, for example.

The inputs to these codes are the ocean optical properties. They can be divided into two classes. These are *inherent* and *apparent* optical properties<sup>29</sup>. Since they are used in performance prediction, these quantities should be defined. Inherent optical properties are optical parameters whose values do not depend on the ambient light field. They are the absorption coefficient, the scattering coefficient (including the phase function) and the attenuation (extinction) coefficient. These parameters appear directly in the transport equations used to model lidar performance, and their physical meaning is unequivocally clear. They are, however, difficult to measure for a number of reasons although considerable progress is being made.

Apparent optical properties depend on the ambient light field. Normally, the ambient light field is a result of solar radiation. This makes such measurements relatively simple, since the radiation source is readily available.

The most commonly measured optical property is the diffuse attenuation coefficient. A detector is lowered into the water and readings are taken. (optical filters can be used if desired). Then, since by definition

$$(5) \quad K_d = \frac{-1}{E_d} \left( \frac{dE_d}{dz} \right),$$

$$(6) \quad E_d(z) = E_d(z_0) \exp \left[ - \int_{z_0}^z K_d(z) dz \right]$$

Another form of (6) will be discussed later when describing lidar based measurements.

Under ideal conditions, Equation (2) holds, with a slowly varying coupling coefficient, Preisendorfer has suggested a  $\beta$  of  $\sim 6$ ; Levin<sup>29</sup> indicated that  $\beta$  is dependent on other inherent optical properties, and should be around 5. For this reason, Secchi measurements were carried out at Panama City, Florida from 10-13 September, 1996 to determine:

1. The most appropriate coupling coefficient
2. The effect of sea state, glint, etc. on Secchi depth
3. The effect of sun angle on Secchi depth.
4. Verification that  $K_a$  ("a") is the "system K" of ML.

These optical measurements were organized by Dr. Jack Lloyd of CSS, and carried out in parallel with independent property measurements made concurrently at the same location by Ms. E. A. Larson of CSS, Panama City. Similar measurements were also taken by APL/JHU personnel. At the same time and in the same location that these *in situ* measurements were being taken, the Magic Lantern imaging lidar system was deployed, and made measurements of a  $K$ , which correlated closely with the measured *in situ*. The results are shown in Table I.



Day	time	$z_D$ , feet	$c$ , $m^{-1}$	$a$ , $m^{-1}$	$K(ML)$ , $m^{-1}$
Sept 11	1130	67	0.27		
	1330	62/64	0.29	0.08	
	1430				0.07
Sept 12	1230	75			
	1330		0.22		
	1430	67			
	1600				0.07
	1615	55-60			0.07
Sept 13	0745	62			
	0830		0.20	0.08	
	1000	72			
	1200	67			
	1230	76			
	1330	81			
	1400				0.08
	1450	75			
	1600	70			
	1630				0.07

Table I

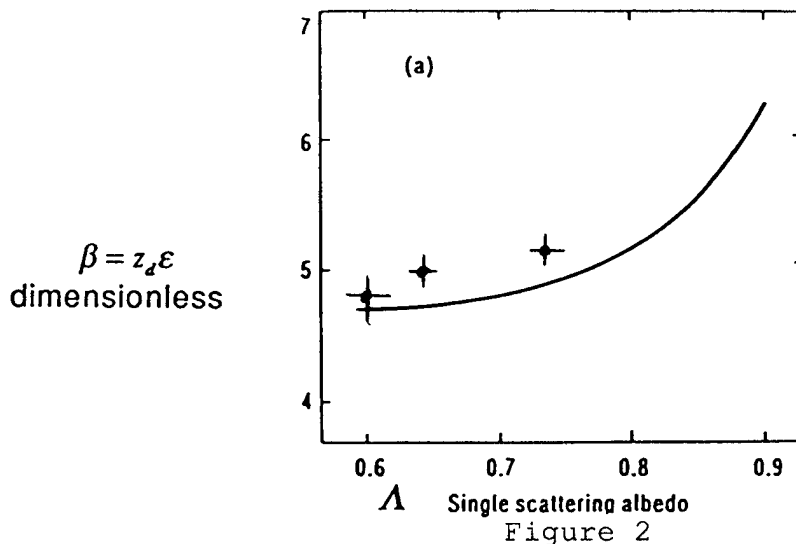
Further discussion of the lidar measurements and their significance will be given later in this paper, with the relevant equations for determining  $K(ML-Magic\ Lantern^{\circledR})$ .

Zege plotted the coupling coefficient against the single scattering albedo (this is  $b/c$ , a term frequently appearing in the Russian Literature), and the Secchi depth against the

extinction coefficient. In Figure 2, the coupling coefficient is the product of the measured Secchi depth and the independently measured extinction coefficient. It is important to note that since the littoral and coastal region are where scattering becomes predominant, the coupling coefficient can be greater than 6. As an extreme case, in Norwegian fjords where there are large amounts of suspended siliceous matter the scattering is substantial and absorption relatively small, the single scattering albedo is high, and the coupling coefficient can be as high as 7 or 8. This result was obtained by Mankowsky, who tried to fit (2) to large amounts of data; and fit none of it well. This dependence is based on a relationship derived by Ivanov<sup>3</sup>,

$$(7) \quad \beta = \frac{1}{1+a/c} \ln \frac{A-r}{rk^*}$$

with the logarithmic terms representing albedo contrast over threshold vision contrast; that is, what is the difference in albedo between the ocean and the Secchi Disc, and what difference can the eye detect?  $\beta$  is only a weak function of these variables, because of their logarithmic dependence. It should also be noted that (7) is equivalent to (3), but is expressed in terms which can be directly related to ocean optics quantities. It is equivalent to other expressions derived by Preisendorfer.



As it can be seen, the data taken agrees well with the Zege curve.

Figure 3 shows the Secchi depth as a function of extinction coefficient

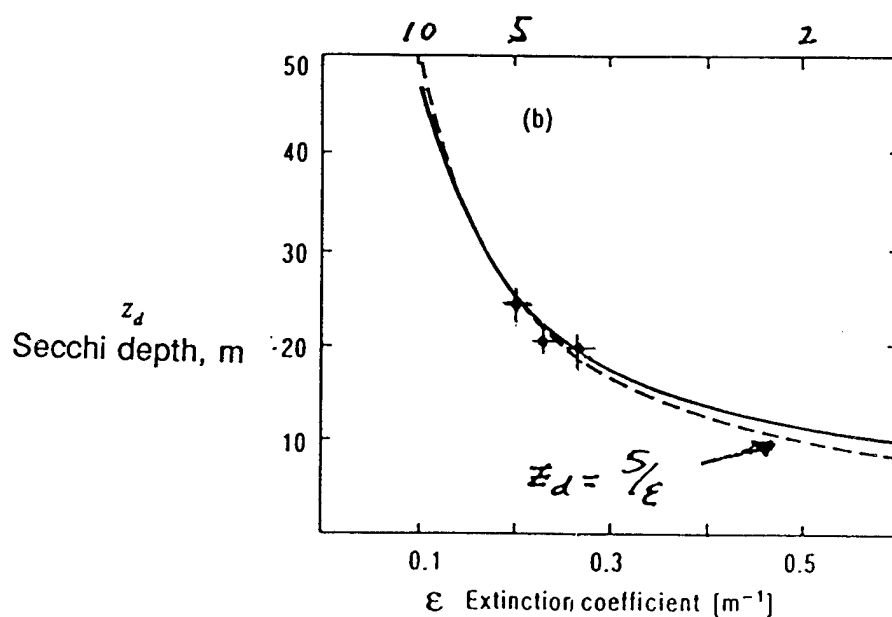


Figure 3

On the last day of the test, since the extinction coefficient varied only slightly with depth and did not change substantially during the day, Secchi runs were made at varying sun angles, to verify the effect on measured Secchi depth. These results are shown in Figure 4. Because water conditions remained constant, these measurements give a reliable indication of the effects of sun angle; therefore this correction can now be applied to Secchi data under all conditions.

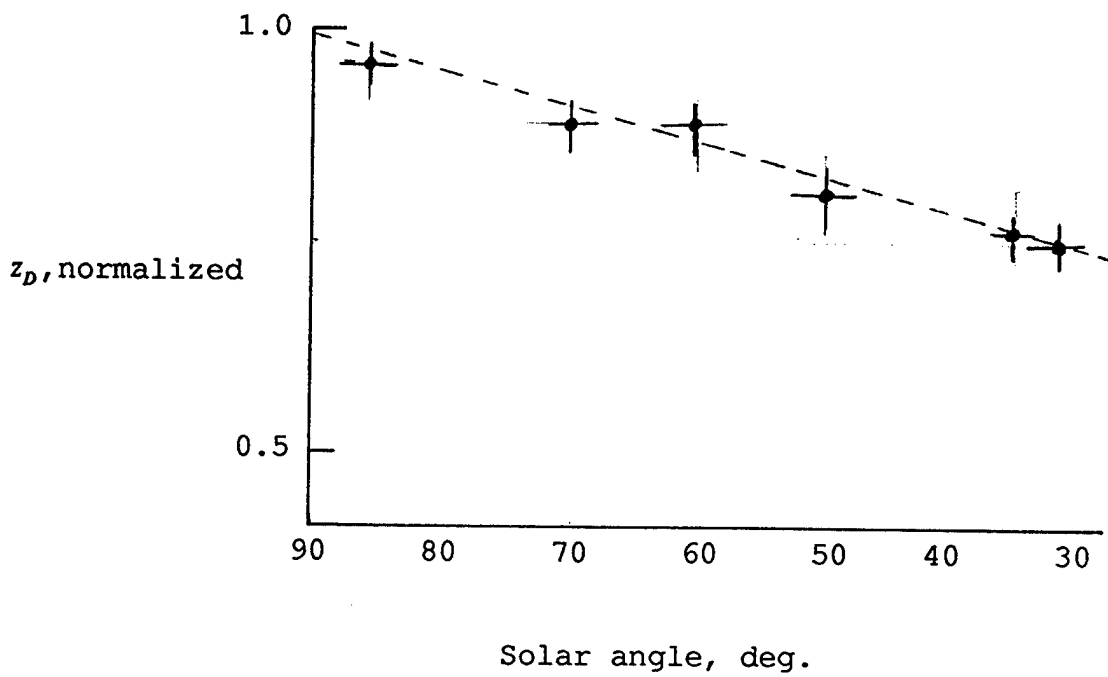


Figure 4

A typical Secchi map is shown in Figure 5. These are some of the data that will be available to the fleet for ocean lidar deployment. Note the lack of resolution.

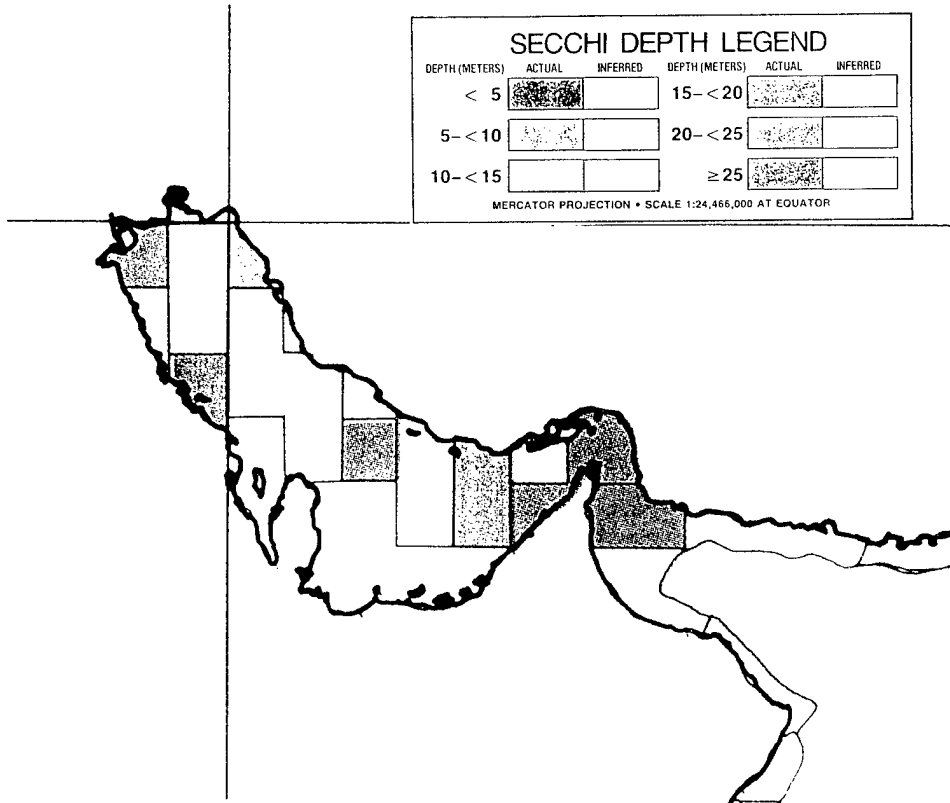


Figure 5

Finally, a word should be aid about the device used to make the Secchi measurements. It is a hollow plastic tube with a plastic window at the bottom. It was lashed to the stern of Mr. Offshore, which had a low freeboard. The Secchi Disc was lowered from the stern two or three feet away. The tube was hooded, and the window was just below the water surface. It could be trained, so that the disc was always in sight. This arrangement was exceptionally successful and produced very reproducible results even between different observers.

#### THE COASTAL ZONE COLOR SCANNER (CZCS)

In October 1978, the Nimbus-7 satellite was launched into orbit. It carried the CZCS scanning radiometer which was designed to provide high quality color images of the ocean during the year's time it was to be operative<sup>30</sup>. CZCS operated, in fact, until 1986, well past its projected lifetime.

CZCS operated in six spectral bands, five in the visible and one in the thermal IR. The active scan was 78°, with a FOV of 0.05°. From 950 km, this provides a ground resolution of 825 m. This resolution is, in fact, more than adequate for military and oceanographic purposes. The CZCS was designed to

provide estimates of near-surface phytoplankton pigments from a measurement of the spectral solar radiance scattered out of the ocean.

It has been shown that these data can be related directly to the diffuse attenuation coefficient<sup>31</sup>. This relationship is:

$$(8) \quad K_D(\lambda) = \phi(\lambda) 1.421^{\psi(\lambda)} \left( \frac{L_{u,443}}{L_{u,550}} \right)^{\psi(\lambda) - 2.124} + K_w(\lambda)$$

where the L terms are the measured normalized radiances, and the functions  $\phi$  and  $\psi$  are empirically determined functions. Austin and Petzold<sup>32</sup> have determined the empirical relationships for these functions, and their procedure has turned out to be quite successful in determining  $K_D(\lambda)$ <sup>33</sup>. An example of data obtained from CZCS is shown in Figure 6.

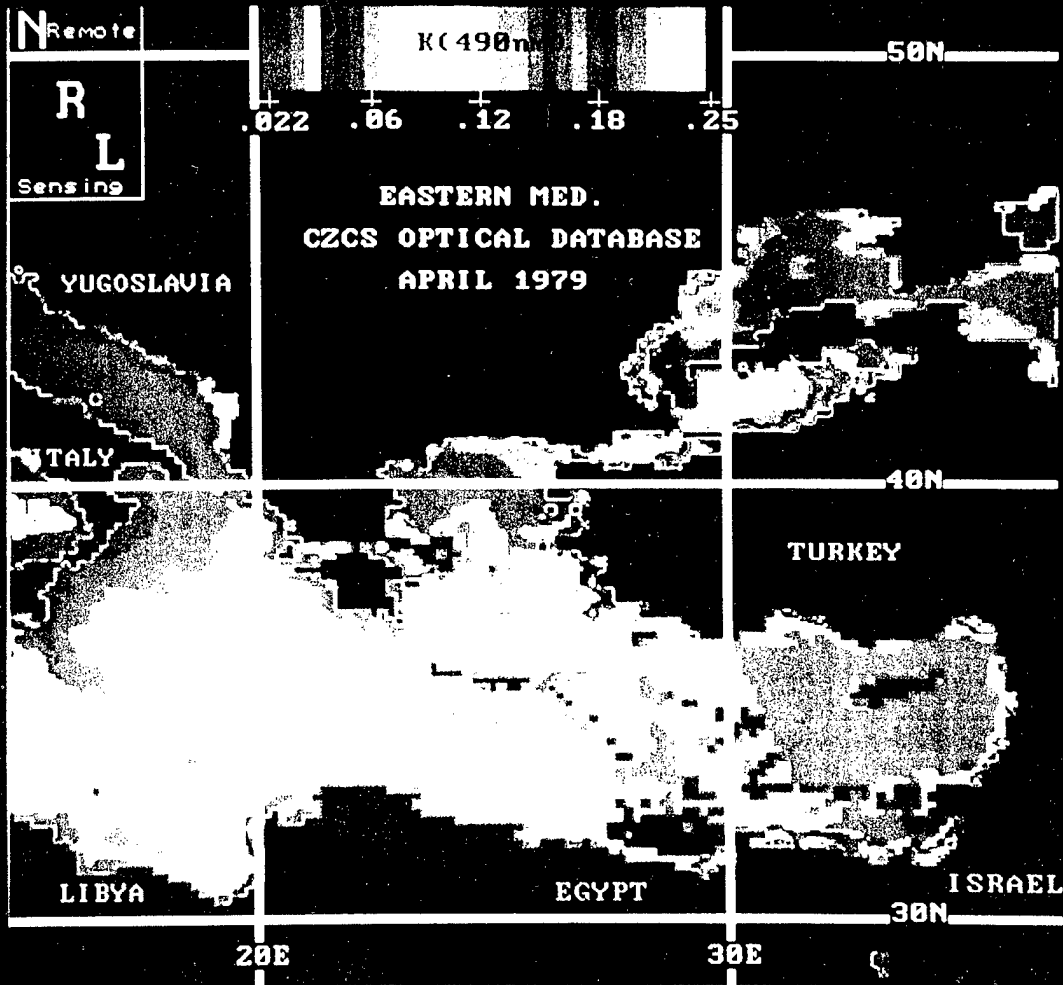


Figure 6

## SEA STATE

The initial attempts to include the effects of sea state were carried out in the early 1980 time frame. Most of these references were Soviet<sup>34,35</sup>. A direct example of sea state effects was pointed out by Zege<sup>36</sup>, and is shown in Figure 7. In this graph, she shows that as a target is imaged at progressively greater depths, the  $S\sqrt{N}$  ratio decreases, then increases, then monotonically decreases. In all cases,  $S\sqrt{N}$  for a given sea state is less than that for a calm sea, and the effect becomes more pronounced with increasing sea state. Ray tracing codes have been used to study these effects, but at present, a general quantitative statistical approach to these effects does not exist. If sufficient data were taken, it might be possible to work out  $S\sqrt{N}$  correlations, and get an idea of the degradation of images as a function of depth.

The basic physics behind this effect is that the action of waves on the ocean surface causes the focusing and defocusing of light as it passes through the water column. For such analyses, it is important to realize that a derived  $S\sqrt{N}$  refers to a given target size. Focusing and defocusing of capillary waves causes noise of small dimensions just below the sea surface. These do not affect larger mine like targets. Focusing and defocusing of gravity waves creates noise at depths in the range of 10-20 feet, depending on sea state, and the dimensions of these noise sources is comparable to that of a mine like target. In addition, as pointed out by Luchinin<sup>37</sup>, there are additional noise components associated with wave action at the surface; the modulation of the height of waves at the surface McLean has attempted to describe some of the implications of earlier Soviet work in comparisons with existing analytical models, but apparently was unaware of the previous work of Zege.

The model of deWeert<sup>27</sup> can be used to simulate these effects. For example, a hypothetical operating imaging lidar system could be chosen. The target could be a 36" sphere of 8% (Lambertian) reflectivity, in Jerlov Coastal water, Class I. The transport codes used in this ray tracing routine are based on This water has an extinction coefficient of  $\epsilon$ ("c"). The



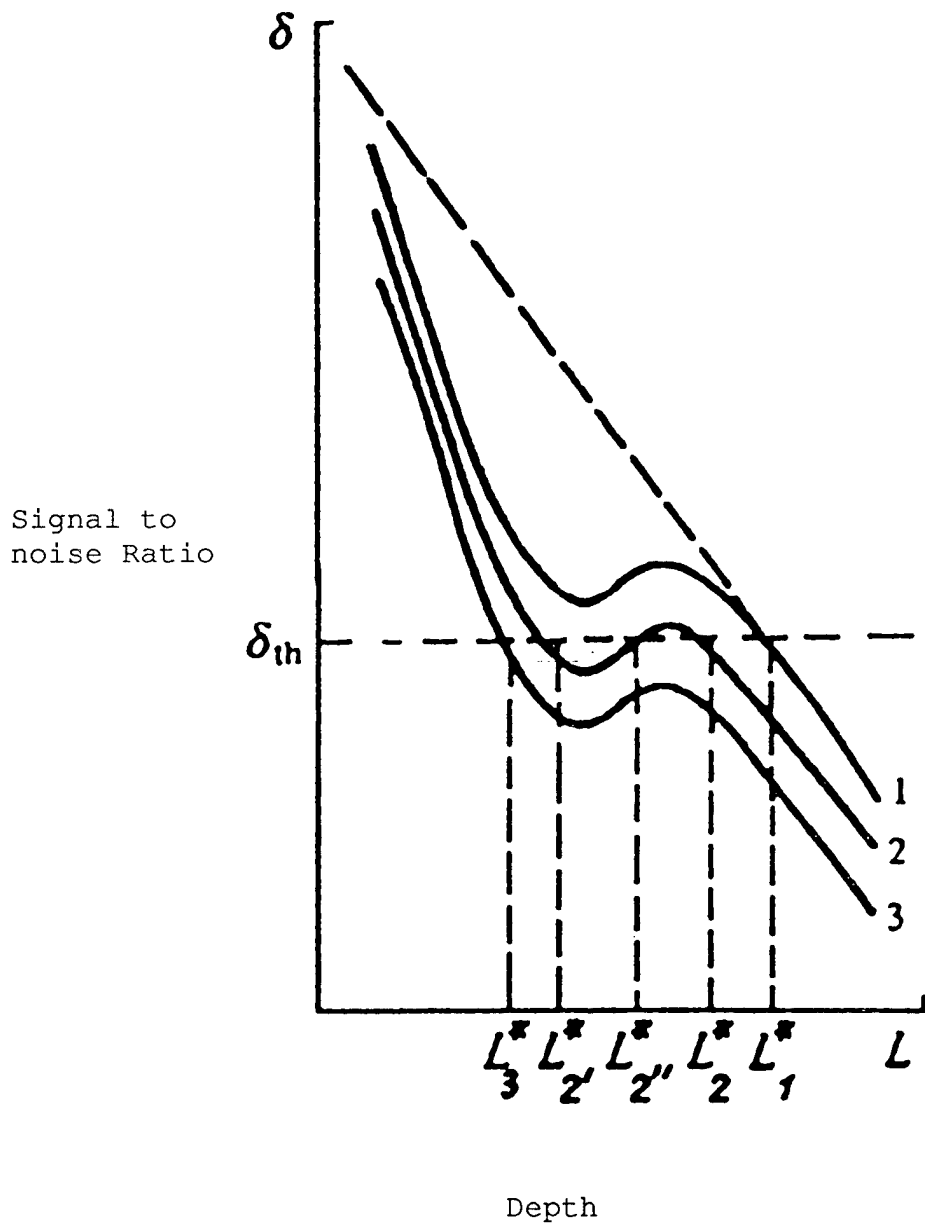


Figure 7

extinction coefficient can be related to  $a$  and  $b$  through relationships given by Gordon and Morel<sup>37</sup>.  $\beta\pi$  is obtained by use of equations derived by Oishi<sup>38</sup>. When Secchi depth is available, the extinction coefficient can be calculated from Equation (3). Thus, it is possible to obtain the SNR from a Secchi depth data for a given area using the ray tracing model.

Although ray tracing might be considered a brute force technique, nevertheless, representations such as these are quite valuable, as they can be extended to various other Jerlov classes of higher water quality, if it is assumed that for a given system the product  $K_d = \text{constant}$ ; that is, for a given system, the product of  $K_d$  (or " $a$ ") and the depth  $d$  is constant (for a given  $S\sqrt{N}$ ). Note: the common notation of  $K_d$  for irradiance coefficient should not be confused with another term unfortunately used in ocean lidar literature;  $K_d$ , the dimensionless product of some attenuation coefficient " $K$ " and the depth,  $d$ .

The Commander in the field, however, is interested in the probability of detection and false alarm rate. He wants to know what are the chances that his sensors might miss a mine, and what delays might be incurred in determining whether a contact is a mine, or a false alarm. It is possible to express probability of detection (POD) as a function of signal to noise ratio (SNR), with false alarm rate (FAR) as a parameter. Using Gaussian statistics<sup>39</sup>, it is possible to prepare a plot of POD vs. SNR, with FAR as a parameter. Thus, with Secchi depth measurements (or CZCS  $K_d$  data) it is possible to obtain the FARs and PODs needed in the field.

These techniques will continue to be improved on, but what is discussed here is the framework of a methodology to provide the basic system performance predictions desired by the fleet.

#### DIRECT MEASUREMENTS MADE BY OPERATING LIDAR SYSTEMS

The Magic Lantern<sup>®</sup> system, for example, can itself be used to make ocean optics measurements, and the results of some of these measurements are shown in Table I. These measurements were taken at the same location and at the same time as the Secchi and *in situ* measurements. This technique has been described previously. Two adjacent gates are taken and the

logarithm of the ratio is then related to the absorption coefficient  $a$  by Equation(8). Here, the  $S_i$  is the camera gain associated with gate  $i$  and  $z_i$  refers to the centerline depth of the gate.

$$(8) \quad a \equiv K_a = \frac{\ln\left(\frac{S_i}{S_j}\right)}{2(z_j - z_i)}$$

The measurement of  $a$  by this technique is radically different than *in situ* measurements. The differences are:

(a) The measurement assumes water homogeneity across the gates imaged. Otherwise, the  $a$  measured is an average. Since gates cannot be decreased to sizes smaller than  $\sim 15$ -20 feet, detailed inhomogeneities cannot be detected.

(b) The optical quantity measured is backscattered light. This requires that  $\beta(\theta)$ , the phase function, be constant in the vicinity of  $180^\circ$ .

(c) The measurement is taken through the air sea interface, and is subject to wave focusing and defocusing going into and out of the ocean.

Since the basis of the measurement is the comparison of camera gain at two adjacent gates, each gate experiences, to some extent, effects (a) through (c). Therefore, these effects will be second order, if that much. The existence of effect (c) leads to the question of whether ML is measuring  $K_d$  or  $a$ . It has been shown previously that a wide area system measures "a" when operating through a smooth sea surface. Since adjacent gates experience the same effects, the  $K$  measured by ML should closely approach  $a$ . Although Russian oceanographers<sup>41</sup>. use a relationship expressing  $K_d$  as a function of "a", when the sun is close to zenith and the sea is calm,  $K_d$  approaches "a" very closely. This was observed in the test results of Table I.

Spot systems can also be used to make oceanographic measurements. In this case, a profile of  $c$  with depth is obtained<sup>42</sup>

$$(9) \quad \varepsilon(z) = \frac{\exp\left[\frac{S(z) - S_m}{k}\right]}{\frac{1}{\varepsilon_m} + \frac{2}{k} \int_z^{z_m} \exp\left[\frac{S(z') - S_m}{k}\right] dz'}$$

More sophisticated relationships can be found in the Soviet literature which take into account laser transmitter beam divergence angle, point spread function and variable phase functions. More interesting, and with no Western counterpart is the remote determination of the scattering coefficient using polarization techniques.

### THE TWA 800 CRASH OFF MORICHES INLET

The crash of TWA Flight 800 on the evening of July 15, 1996 has been well documented and thoroughly discussed. The Oceanographer of the Navy recently gave a thorough description of the recovery efforts that took place immediately after this disaster<sup>42</sup>. These efforts were not immediate, as several days were required to locate the major portions of the wreckage. A schematic of the flight pattern and the debris field is shown in Figure 8.

Had the Magic Lantern system been fielded, the debris could have been located almost immediately, and sonar and laser line scanners deployed for a detailed investigation of the wreckage. It should be pointed out immediately that the problem of locating bottomed objects is more difficult than locating floating or suspended objects. In looking for bottomed objects, the critical variable is the albedo ratio; that is, the ratio of the object's albedo to the albedo of the bottom. In this situation, the searchers were fortunate. The water, ranging from ~ 80 - 110 feet deep, has what is called a "white bottom", with an albedo of 0.25 to 0.30. The high albedo exists in part because of the area is not in close proximity to the Hudson river outflow, much of the silt from the Hudson and Connecticut rivers depositing in Long Island Sound. The area was on the Continental Shelf in relatively shallow water. TWA indicated that the debris would be aluminum, with a reflectivity of 70-80% and other debris with reflectivity of 5-15%. Thus, the requirement of albedo contrast was met. As an added benefit, Magic Lantern easily detects floating debris in obscuration, operating better at night than in daylight.

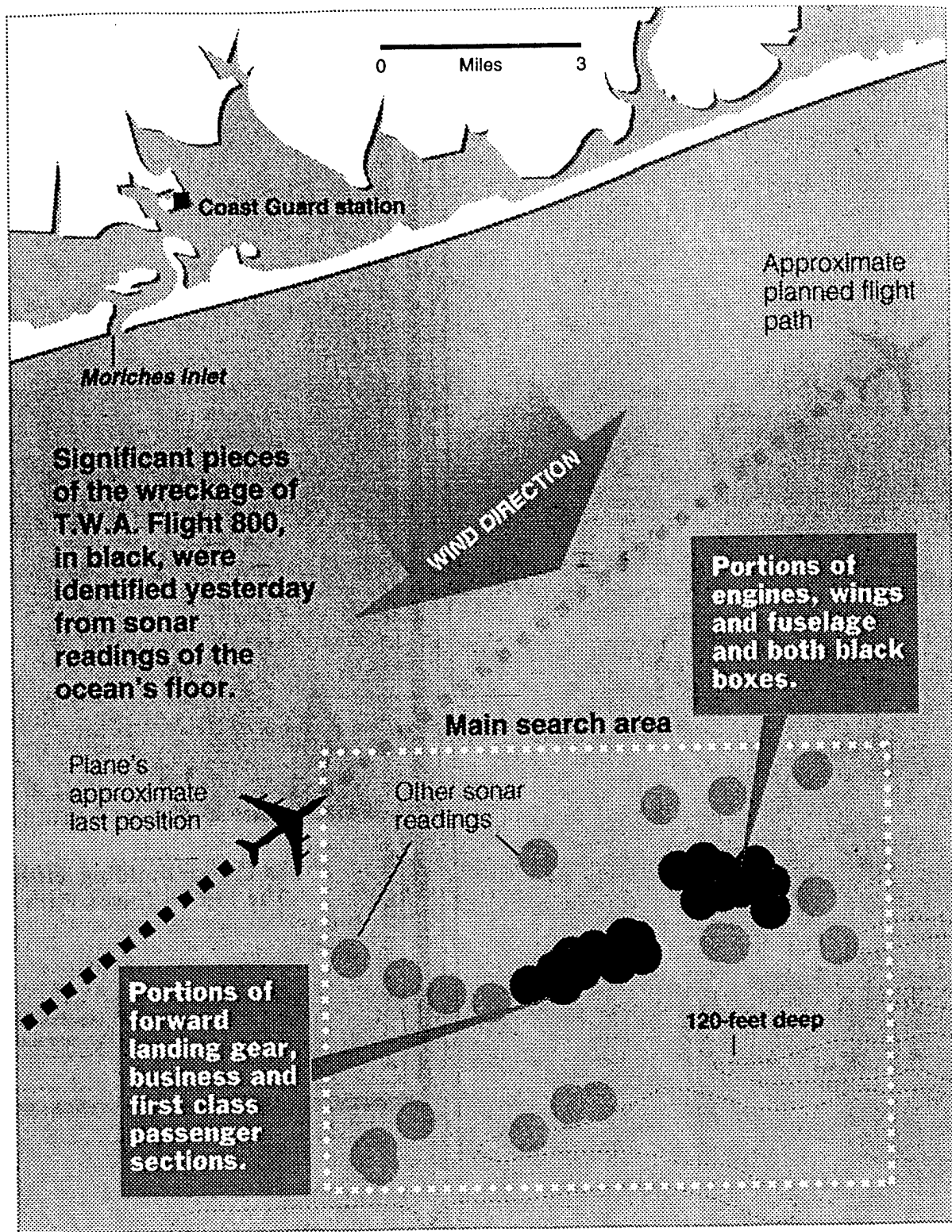


Figure 8

The remaining questions involve water turbidity and Sea State. This area is frequently visited by oceanic gyres spinning off the Gulf Stream and the water is clearer than would be expected for water so close to the shore. Figure 9 is an excerpt from a NOAA report<sup>43</sup>. It can be seen that the water is roughly Jerlov Class II. This was confirmed by Secchi measurements taken in the area at about the same time. Note that in this document, the ocean optical property cited is the optical transmissivity as a function of depth.

For two or three days after the disaster, the sea was relatively calm, and the sea state, 0-1. After that time the winds picked up, and the sea state increased to 1-2.

The results of ray tracing code runs<sup>27</sup> are shown in Figures 10-12. In Figure 10, simulated 2' diameter aluminum structural items (reflectivity = 80%) are imaged against a sandy bottom (reflectivity = 20%) at 100 feet depth. The lidar system is 800 feet above the ocean surface. The water is Jerlov Class II. In Figure 11, the sea state is 1, and the target images are rippled because of surface wave action. In Figure 12, the sea state is calm; the water is Jerlov Class III. Here, the targets were 6' x 6'. In all these simulations, the structural members were clearly visible. When the items were of low reflectivity, comparable detectability is observed.

In conclusion, the deployment of the Magic Lantern system within 24 hours of the TWA Flight 800 crash could have led to the localization of major items in the underwater debris field some 4-5 day earlier than they were actually found.

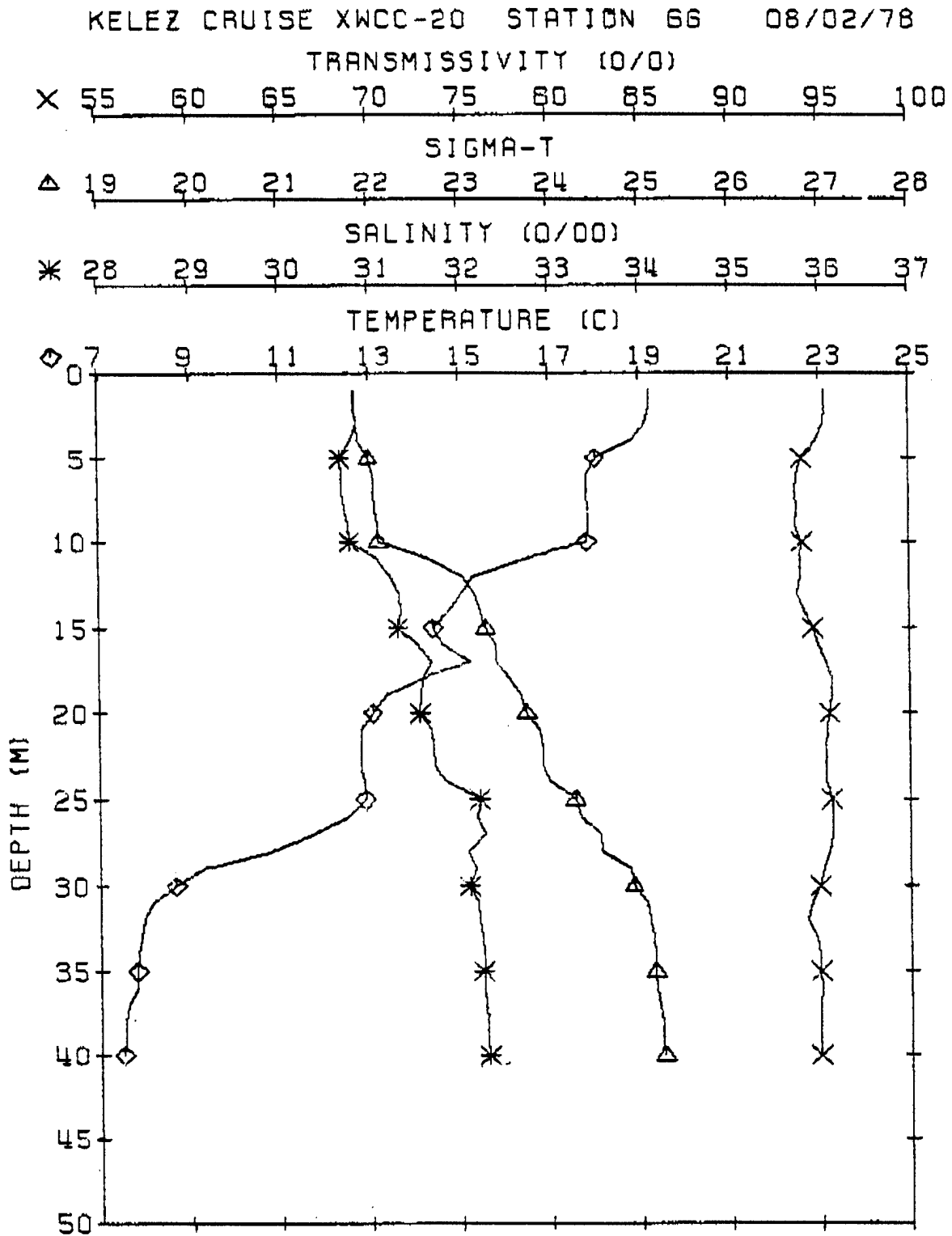


Figure 9

9-70

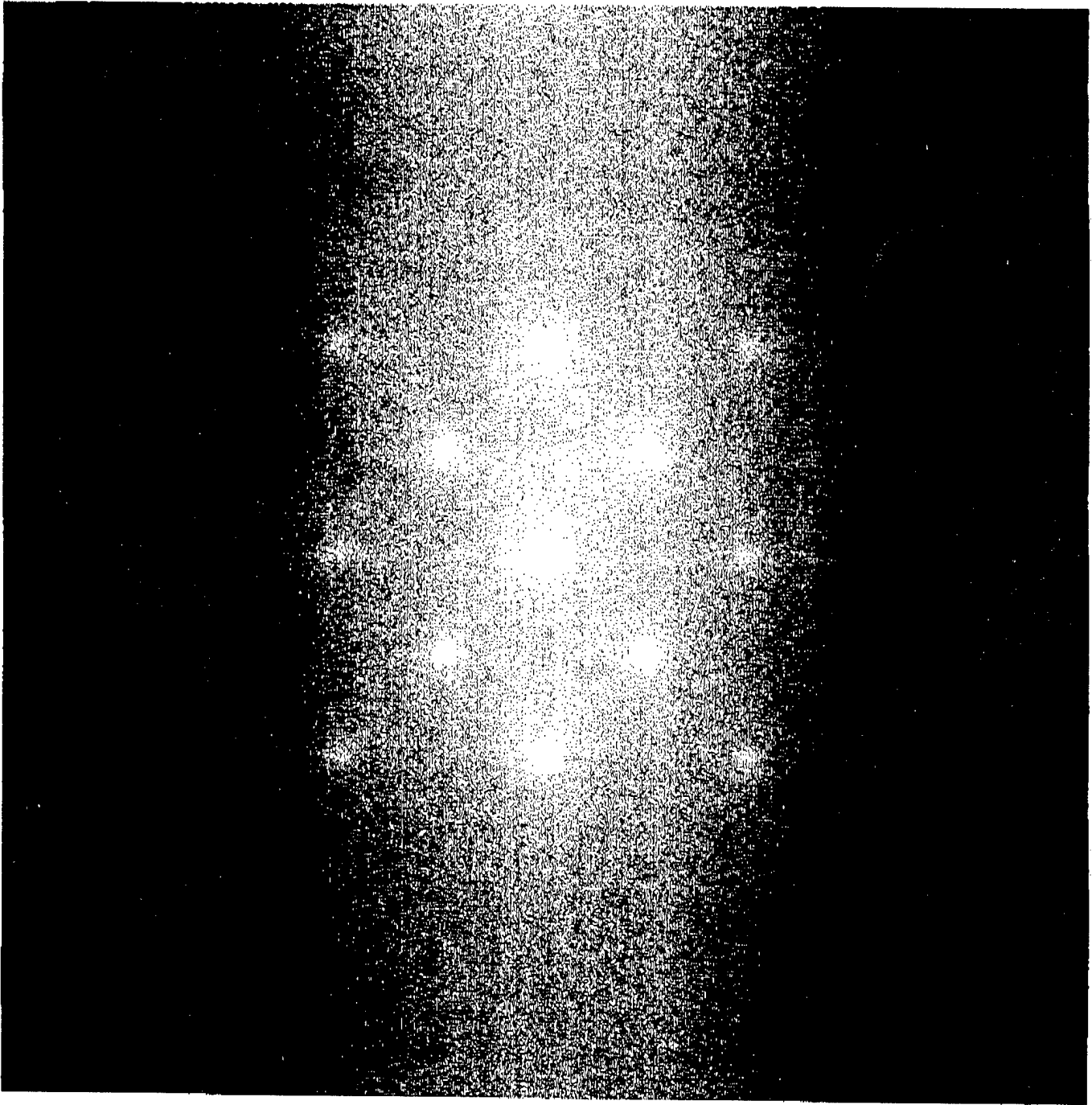
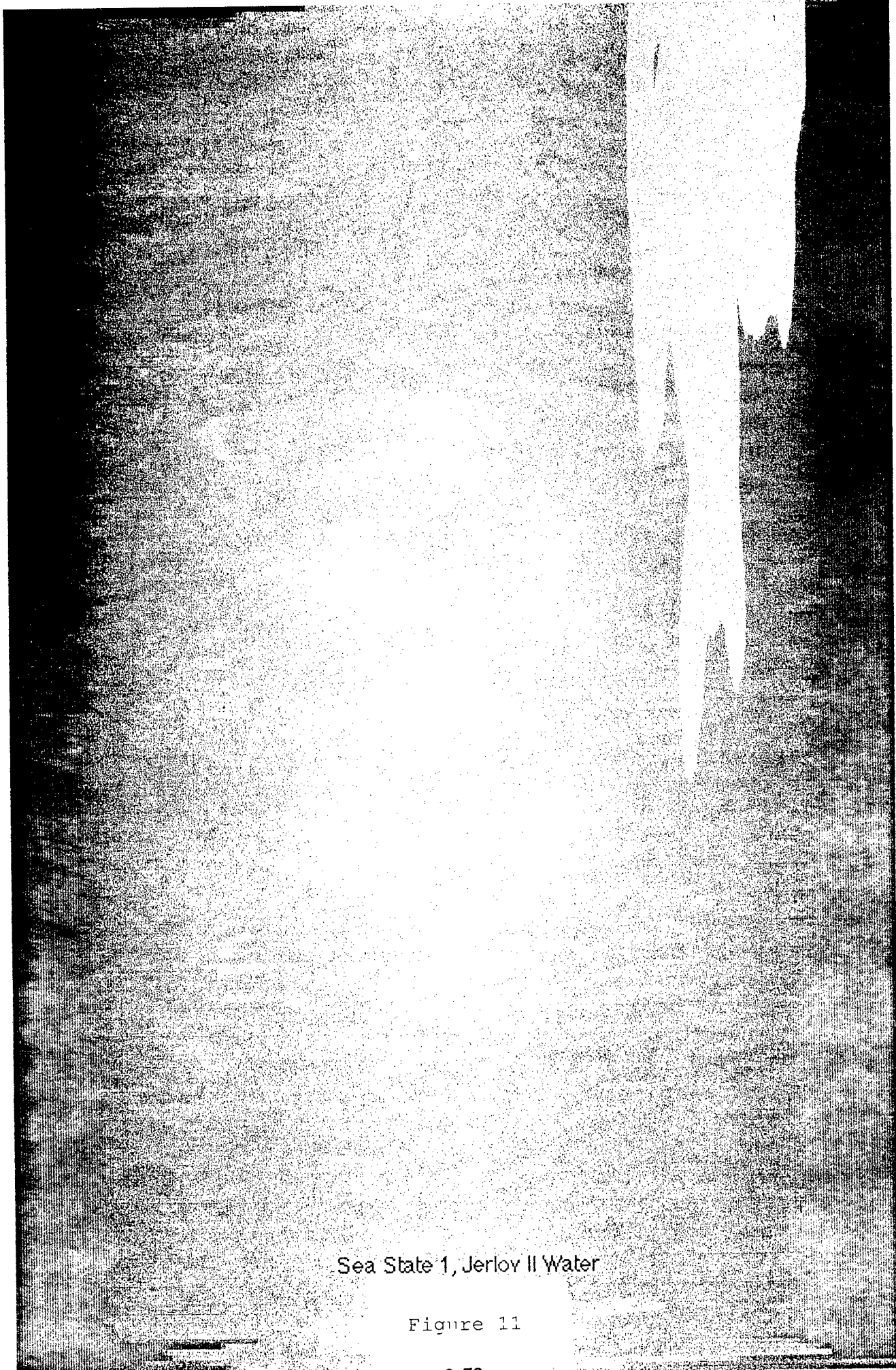


Figure 10





Sea State 1, Jerlov II Water

Figure 11

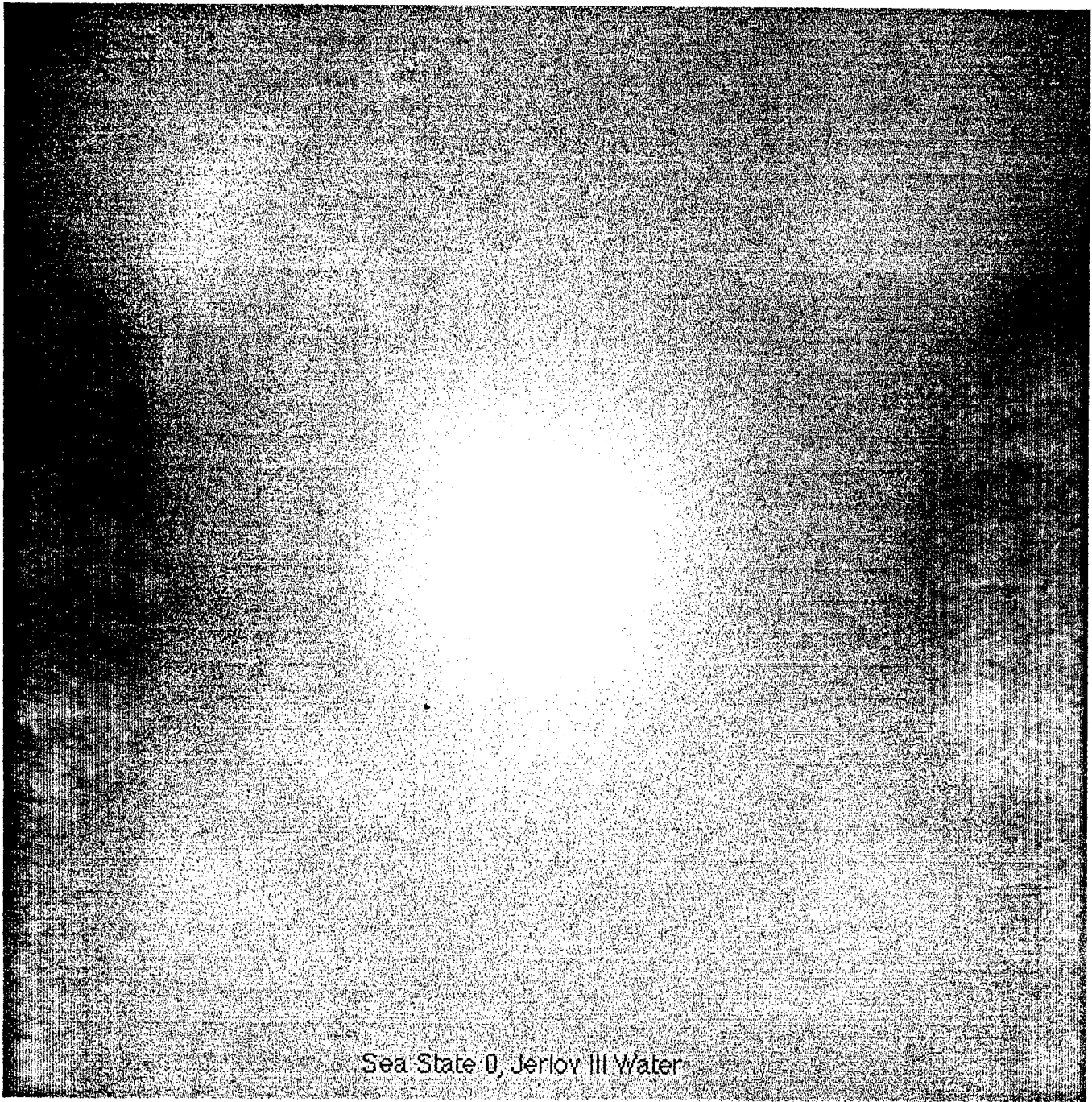


Figure 12

## REFERENCES

1. Arnone, Robert A. *Coastal Secchi Depth Atlas*, NORDA Report 83, Naval Ocean Research and Development Activity, NSTL, Mississippi, 1985
2. Frederick, M. A. *An Atlas of Secchi Disc Transparency Measurements and Forel-Ule Color Codes for the Oceans of ten World*, MS Thesis, U. S. Naval Postgraduate School. Monterey, California, 188 pp., 1970
3. Ivanov, A. P. *Physical Principles of Hydrooptics*, Nauka i Tekhnika, Minsk, 1975, pp. 349-405
4. Mankovsky, V. I., *Okeanololog.* **17**, 750-53(1978)
5. These data are available through the internet and can be accessed at <http://www7240.nrlssc.navy.mil/ocolor/ocean.html>.
6. See, for example, Larson, E. A., ML(ADM) Model DT-1A Test, Oceanographic Test Report, July 19 to August 9, 1996, CSS Code 3310, Oceanographic Support Group, Panama City, Florida.
7. Maffione, R. A. and D. R. Dana, "Instruments and methods for measuring the backward scattering coefficient of ocean waters.", preprint, Sequoia Scientific Inc. Mercer Island Washington; to be published in the proceedings of Ocean Optics XIII, Halifax, Nova Scotia, October 22-25, 1996
8. Pegau, W. S. et al., *J. Geophys. Res.* **100**, 13,201(1995)
9. Preisendorfer, R. W. NOAA-PMEL Technical Memorandum ERL PMEL-67, Pacific Marine Environmental Laboratory, Seattle, Washington, April 1986, 90 pp.
10. Tucker, S. P., *A Bibliography of Optical Oceanography*, Oceanography Department, Naval Postgraduate School, Monterey, California (1970)
11. Murdock, J. H., *The Transparency of Southeast Asia and Indonesian Waters*, M. S. Thesis, Oceanography Department, Naval Postgraduate School, Monterey, California (1980)

12. Van Norden, M. F. and S. E. Litts, The Transparency of Selected U. S.. Coastal Waters with Application to Laser Bathymetry, Oceanography Department, Naval Postgraduate School, Monterey, California (1979)
13. Tucker, S. P., A Bibliography of Hydrooptics in the Soviet Union, Oceanography Department, Naval Postgraduate School, Monterey, California (1970)
14. Keeler, R. N., Proceedings of the Autonomous Vehicles in Mine Countermeasures Symposium, U. S. Naval Postgraduate School, Monterey, California, 4-7 April 1995, p 6-14
15. Setter, C. and R. J. Willis, Proceedings of the Sixth Biennial National Ocean Service International Hydrographic Conference, April 18-23, 1994, Norfolk Virginia, The Hydrographic Society of America, Rockville, Md., p.134
16. Lillycrop, W. J., et al. Proceedings of the Sixth Biennial National Ocean Service International Hydrographic Conference, April 18-23, 1994, Norfolk Virginia, The Hydrographic Society of America, Rockville, Md., p.144
17. A. Secchi, in A. Cialdi, Sur moto ondoso del mare e su le correnti di esso specialmente auquelle littorali, 2nd ed. p 258-288, Department of the Navy, Office of the Chief of Naval Operations, ONI Translation A-655, Op-923 M4B, 21 December, 1955.
18. Preisendorfer, R. W., Limnol. Oceanogr. **31**(5) 909 (1986)
19. Gershun, A., Tr. Gos. Okeanogr. Inst. **11**, 99(1936)
20. Levin, I. M., Izv. Atm. Okean. Phys. **16**, 678 (1980)
21. Tyler. J. E., Limn. and Oceanogr. **13**, 1(1968)
22. Blackwell, H. R., J. Opt. Soc. Am. **36**. 624 (1946)
23. Wyzecki, G. and W. S. Stiles *Color Science; Concepts and Methods* John Wiley and Sons, New York, New York, 2nd ed, 1982
24. Holmes, R. W., Limn. Oceanogr. 15,688 (1970) as corrected by Højerslev, N. K., SPIE 637; paper 637-37 (1986)
25. Zaneveld, J. R., J. Geophy. Res. **98**. C11, 20,236 (1990)

26. Haimbach, S. and R. F. Lutomirsky, Proceedings of the Sixth Biennial National Ocean Service International Hydrographic Conference, April 18-23, 1994, Norfolk Virginia, The Hydrographic Society of America, Rockville, Md., p.200
27. deWeert, M. J., "Imaging Lidar Model with Surface Waves", Kaman Aerospace EODC, Kaman Corporation, Tucson Arizona, 1996
28. Moran, S. E. and R. D. Campbell, "Imaging Lidar Model" SAIC, Electrooptic Division, San Diego, California, 1993
29. Preisendorfer, R. W., J. Mar. Res. **18**, 1(1959)
30. Levin, I. M. Izv. Akad. Nauk SSSR, Fiz. Atmos. Okeana **16**, No. 9 926(1980)
31. Gordon, Howard R. and A. Morel, *Remote Assessment of Ocean Color for Interpretation of Satellite Visible Imagery*, Springer Verlag, New York, New York, 1983 p. 3
32. *Oceanographic Applications of Remote Sensing*, CRC Press, Boca Raton, Florida, M. Ikeda and F. Dobson, eds., 1995, p. 167
33. Austin, R. W. and T. J. Petzold in *Oceanography from Space*, Gower, 1981, p 239
34. Luchinin, A. G., and I. A. Sergievskaya, Izv. Akad. Nauk SSSR, Fiz. Atmos. Okeana **18**(8), 850 (1982)
35. Luchinin, A. G., and I. A. Sergievskaya, Izv. Akad. Nauk SSSR, Fiz. Atmos. Okeana **22**(7), 773(1986)
36. Zege, E. P. et al., Atmos Ocean Opt. **5**(8), 510(1992)
37. McLean, J. W. and J. D. Freeman, Appl. Opt. **35**(18), 3261(1966)
38. Gordon, and mMrel
- 39 Oishi, T., Appl. Opt. **29**, 4658(1990)
- 40 deWeert, M. J., unpublished work, Kaman Aerospace EODC, Kaman Corporation, Tucson, Arizona, 1996
- 41 Keeler, R. N., "Imaging Lidar Systems and K-Meters Employing Tunable and Fixed Frequency Lasers" U. S. Patent 5,091,778 dtd February 25, 1992.(in a previous patent, Ulich, 4,963,024, dtd October 16, 1990, the "system K" is compared with K<sub>d</sub>)

42 Ivanov, A. P., et al. Izv. Akad. Nauk SSSR, Fizika Atmosferi Okeana, **9**(10),1101(1973)

43. Hoge, F. R. et al., Appl. Opt. **27**(19), 3969(1988)

44. RADM Paul E. Tobin, Oceanographer of the Navy Keynote Address, Symposium on Technology and the Mine Problem, U. S. Naval Postgraduate School, Monterey California, November 18, 1996

45. NOAA Technical Memorandum OMPA-16, "Analysis of the Accuracy of the Inter Ocean CSTS Sensors Used on the Mesa New York Bight Project, Boulder, Colorado 1982



# The Mechanics and Control of Biomimetic Robotic Locomotion

Joel Burdick, Bill Goodwine  
Dept. of Mechanical Engineering  
California Inst. of Technology  
Pasadena, CA 91125

Jim Ostrowski  
Dept. of Mechanical Engineering  
University of Pennsylvania  
Philadelphia, PA

**Abstract:** *This paper uses geometric methods to study basic problems in locomotion. We consider in detail the case of "undulatory locomotion," which is generated by a coupling of internal shape changes to external nonholonomic constraints. Such locomotion problems can be modeled as a connection on a principal fiber bundle. The properties of connections lead to simplified results for both the dynamics and controllability of locomotion systems. We demonstrate the utility of this approach on a novel "Snakeboard" and a multi-segmented serpentine robot which is modeled after Hirose's ACM.*

In an attempt to derive strong results for specific examples, prior locomotion studies have focused either on a particular set of locomotion assumptions (such as the quasi-static assumption) or on a particular robot morphology (such as a biped, quadruped, or snake-like robot). However, results derived for one morphology typically do not extend to other morphologies. Cost effective and robust deployment of robotic technology will require a more comprehensive and general approach to the analysis, design, and control of robotic locomotion. A practically useful theory of robotic locomotion analysis and control would have the following properties:

## 1 Introduction and Motivation

It may be useful or essential for future robotic systems that are aimed at mine countermeasure and mine removal applications to be capable of highly complex and adaptable locomotion. The need for complex robot locomotion behavior is not peculiar to mine countermeasures, and consequently a large body of research has developed in the area of robotic locomotion, since mobility is an important capability for autonomous systems. Most mobile robots are wheeled vehicles, since wheels provide the simplest means for mobility. The assumption that these wheels do not slip provides nonholonomic kinematic constraints on a vehicle's motion, and these kinematic nonholonomic systems have been extensively studied [19, 22, 26, 32].

Robotics researchers have also considered *biomimetic* forms of locomotion, such as legs and/or tracks, to generate robot movement. Multi-legged quasi-static locomotion has been the most extensively studied means of legged locomotion, and several quadrupedal and hexapedal robots have been successfully developed and demonstrated [8, 34]. Beginning with Raibert [31], hopping robots have received considerable attention [17, 23, 35]. Bipedal walking and running has also been an active area of study [9, 15, 21, 24]. Other researchers have investigated various forms of "snake-like" locomotion [4, 7, 13], as snake-like robots can potentially access environments, such as tunnels and pipes, that are inaccessible to legged or wheeled vehicles.

- the theory is not constrained to a particular morphology.
- the theory can be implemented in automated software tools that will enable future robotic system designers to more rapidly design and evaluate robotic locomotion platforms.
- the theory has rigorous mathematical underpinnings so that the performance of systems based on the theory can have predictable, provable, and verifiable properties.

Such a theory is currently beyond our reach. However, it is our belief that the development of such a theory will be essential for widespread deployment of robust and cost effective robotic systems with non-trivial locomotion capability. This paper reviews some of our efforts aimed at developing such a locomotion theory.

In virtually all forms of biomimetic locomotion, the basic process of movement arises by coupling a periodic internal deformation of the mechanism to an interaction between the robot and its environment. In the case of *undulatory* locomotion, the constraint is a smooth, but perhaps continually varying, one. Common biological examples of undulatory locomotion include worms and snakes (where the coupling is due to friction), and fish (where the coupling is a fluid interaction). For systems with legs, the constraint of legged contact is nonsmooth.



We review in this paper the mechanics of undulatory systems whose constraints take the form of a continuous nonholonomic kinematic constraint. This class of systems includes most “snake-like” vehicles. We show that such systems can naturally be described as a *connection* on a *principal fiber bundle*. Second, we introduce a specialized form of the dynamical equations for mechanical systems with Lagrangian symmetries and nonholonomic constraints. Third, we show how these results lead to a simple and appealing insight into undulatory locomotion. Finally, we show that the framework is a superset of prior work on the mechanics of wheeled nonholonomic vehicles and free-floating satellites. The ideas are illustrated by two examples: a “snakeboard” and a serpentine robot which is roughly modeled on Hirose’s Active Cord Mechanism. The extension of these ideas to legged systems is briefly reviewed, and more details can be found in Ref. [10].

## 2 Relation to Previous Work

While there is a vast literature on robotic locomotion, very few works have attempted to uncover the underlying mathematical structure that is common to all locomotion systems.

One of the earliest relevant works is that of Shapere and Wilczek [33] who studied the movement of small organisms through a highly viscous fluid. Using gauge theory (which is the language used by physicists for a connection), they have shown how the organism’s net displacement results from cyclical changes in the shape of the body.

More recently, Chirikjian and Burdick coined the term *hyper-redundant* to describe robots with a very large number of degrees of freedom, such as snake-like robots. Chirikjian and Burdick considered locomotion schemes that were reminiscent of the sidewinding [4] and creeping [7] gaits of snakes. They also considered gaits that are analogous to those of inchworms and earthworms.

Kelly and Murray [16] have modeled a number of locomotive systems, such as idealized inch-worms and sidewinding snakes, using kinematic constraints. They show how these systems can be modeled using a *principal kinematic connection* (which is described below). They also provide results on controllability, as well as an interpretation of movement in terms of geometric phases.

Tsakiris and Krishnaprasad [18] have investigated the movement of Variable Geometry Truss (VGT) mech-

anisms which employ no-slip wheel constraints. They term these models “*G*-snakes” since each mechanism segment must move within a subset of a Lie group, *G*. Hence, the mechanisms’ configuration space is a principal fiber bundle, and the kinematic constraints define a principal kinematic connection.

Many locomoting mechanisms use wheels to provide nonholonomic kinematic constraints on the robot’s motion. These nonholonomic systems have largely been treated as purely *kinematic* systems, i.e. their dynamics are constrained in a manner such that only configuration *velocities* need be considered. This assumption has led to some excellent progress in areas such as controllability [2] stabilization [6] and trajectory generation [27]. The framework outlined below includes all of these systems as a special case. Dynamic effects are *essential* to the motion of some systems. In one class of systems, momentum conservation laws are treated as a type of *internal* nonholonomic constraint. These problems primarily arise in rigid body reorientation, such as the spinning satellite [5, 28, 36] and the falling cat [25]. There are a number of systems, such as the snakeboard example that is considered below [20], where *both* kinematic constraints and symmetry (dynamic) constraints come into play. These *mixed* nonholonomic systems have rarely been treated in the literature. Of notable exception is Ref. [2], where control results were established for the restrictive assumption that the unconstrained directions are fully actuated, and Ref. [3] which has been a valuable foundation for many of the results presented here.

One of the earliest studies of snake-like robots was conducted by Hirose [11, 13]. Hirose formulated a *serpenoid* curve—a curve representing the path that a snake would trace out as it slithers forward. Hirose showed that a snake-like vehicle could generate a net forward force by applying torques along the length of its body in the manner dictated by the serpenoid curve. To demonstrate these results, he built a snake-like robot capable of propelling itself forward using only internal torques. In the ensuing sections, we develop a framework for understanding and controlling such systems.

## 3 Background

It is always possible to divide a locomoting robot’s configuration variables into two classes. The first set of variables describes the *position* of the robot, which is the displacement of a coordinate frame attached to the moving robot with respect to a fixed reference frame. The set of frame displacements is

$SE(m), m \leq 3$ , or one of its subgroups—i.e., a Lie group. The second class of variables defines the internal configuration, or *shape*, of the mechanism. We only require that the set of all possible shapes (the “shape space”) be described by a manifold,  $M$ . The total configuration space is  $Q = G \times M$ . The shape and position variables are coupled by the constraints acting on the robot. Hence, by making changes in the shape variables, it is possible to effect changes in the position variables through the constraints. The relationship between shape changes and position changes can be described by a *connection*.

Let's first consider the conventional Lagrangian approach for studying the dynamics of locomotion systems. We assume the existence of a Lagrangian function,  $L(q, \dot{q})$ , on  $TQ$  and  $k$  constraints which are linear in velocities:

$$\omega_j^i(q) \dot{q}^j = 0, \quad \text{for } i = 1 \dots k, \quad j = 1, \dots, n. \quad (1)$$

This class of constraints includes most commonly investigated nonholonomic constraints. In conventional engineering mechanics, the constraints are incorporated into Lagrange's equations through the use of Lagrange multipliers,  $\lambda$ :

$$\frac{d}{dt} \left( \frac{\partial L}{\partial \dot{q}^i} \right) - \frac{\partial L}{\partial q^i} + \lambda_j \omega_j^i - \tau_i = 0, \quad \text{for } i = 1, \dots, n; \quad j = 1, \dots, k \quad (2)$$

where  $\tau$  is a forcing function.

**Example #1:** Consider the two wheeled planar mobile robot shown in Fig. 1. The robot's position,  $(x, y, \theta) \in SE(2)$ , is measured via a frame located at the center of the wheel base. The wheels' angles,  $(\phi_1, \phi_2)$ , are measured relative to vertical. Each wheel is assumed to rotate independently and without slipping. The configuration space is  $Q = SE(2) \times (S^1 \times S^1)$ . The Lagrangian for this problem is:  $L = \frac{1}{2}m(\dot{x}^2 + \dot{y}^2) + \frac{1}{2}J\dot{\theta}^2 + \frac{1}{2}J_w(\dot{\phi}_1^2 + \dot{\phi}_2^2)$ , where  $m$  is the mass of the robot,  $J$  is its inertia, and  $J_w$  is the inertia of each of the wheels. The constraints defining the no-slip condition can be written as in Eq. (1). However, we will rearrange the constraints into the more revealing form:

$$\begin{bmatrix} \cos \theta & \sin \theta & 0 \\ -\sin \theta & \cos \theta & 0 \\ 0 & 0 & 1 \end{bmatrix} \begin{bmatrix} \dot{x} \\ \dot{y} \\ \dot{\theta} \end{bmatrix} = \begin{bmatrix} \frac{\rho}{2}(\dot{\phi}_1 + \dot{\phi}_2) \\ 0 \\ \frac{\rho}{2w}(\dot{\phi}_1 - \dot{\phi}_2) \end{bmatrix} \quad (3)$$

The motion in the group variables,  $(\dot{x}, \dot{y}, \dot{\theta})$ , is strictly a function of the motion in the internal shape variables,  $(\dot{\phi}_1, \dot{\phi}_2)$ , since there are three independent kinematic constraints on the 3-dimensional set of body displacements. If we assume that the base variables are controllable, then given the time evolution

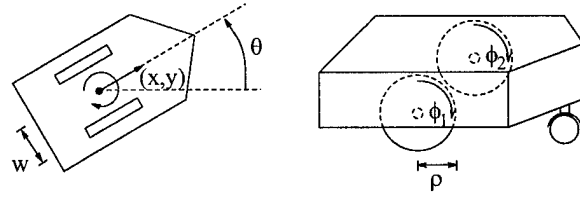


Figure 1: Two wheeled planar mobile robot.

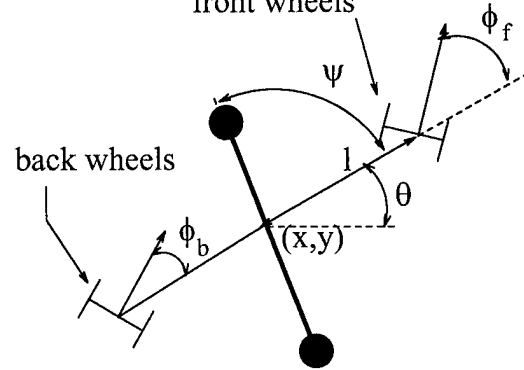


Figure 2: The simplified model of the Snakeboard

of  $(\phi_1, \phi_2)$ , we can completely solve for the robot's motion using Eq. (3). Hence, Eq. (3) describes the relationship between the robot's “internal” motions and its net movement.

**Example #2:** The *Snakeboard* [20, 29] is a variant of the skateboard in which the passive wheel assemblies can pivot freely about a vertical axis. By coupling a twisting of the human torso with a turning of the wheels, a rider can generate a snake-like locomotion pattern *without* having to kick off the ground. A simplified model that captures the essential behavior is shown in Fig. 2. It consists of a rigid body connecting the two sets of wheels. The angle of the wheel axles can be independently specified. A momentum wheel rotates about a vertical axis through the center of mass. By a proper choice of the relative frequency and phasing of the main rotor rotation with the wheel axles' rotations, the snakeboard can move in any direction. Fig. 3 shows a robotic snakeboard prototype.

The snakeboard's position variables,  $(x, y, \theta) \in SE(2)$ , are determined by a frame affixed to its center of mass. The shape variables are  $(\psi, \phi_b, \phi_f)$ , and so  $Q = G \times M = SE(2) \times S^1 \times S^1 \times S^1$ . The Lagrangian is

$$L = \frac{1}{2}m(\dot{x}^2 + \dot{y}^2) + \frac{1}{2}J\dot{\theta}^2 + \frac{1}{2}J_r(\dot{\psi} + \dot{\theta})^2 + \frac{1}{2}J_w((\dot{\phi}_b + \dot{\theta})^2 + (\dot{\phi}_f + \dot{\theta})^2) \quad (4)$$

where  $J$  is the snakeboard body inertia,  $J_r$  is the rotor inertia,  $J_w$  is the inertia of the wheels about

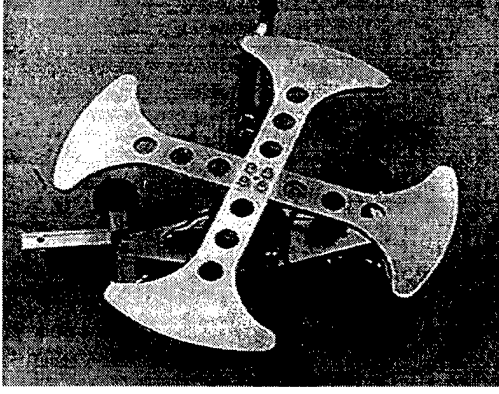


Figure 3: A prototype robotic snakeboard

a vertical axis, and  $\hat{J} = J + J_r + 2J_w$ . Control torques at the rotor and wheel axles are assumed, so  $\tau = (0, 0, 0, \tau_\psi, \tau_b, \tau_f)$ . The assumption that the wheels do not slip in the direction of the wheel axles determines two constraints of the form of Eq. (1):

$$\begin{aligned} -\sin(\phi_f + \theta)\dot{x} + \cos(\phi_f + \theta)\dot{y} + l \cos(\phi_f)\dot{\theta} &= 0 \\ -\sin(\phi_b + \theta)\dot{x} + \cos(\phi_b + \theta)\dot{y} - l \cos(\phi_b)\dot{\theta} &= 0. \end{aligned} \quad (5)$$

There are not enough kinematic constraints to uniquely define the Snakeboard's motion. The technique that was employed in Example #1 to use the kinematic constraints to solve for the robot's motion as a function of shape changes is therefore no longer viable. The snakeboard's dynamics must come into play. To determine the robot's dynamics, engineers have traditionally been relegated to substituting the Lagrangian and the constraints into Eq. (2) and explicitly solving for the Lagrange multipliers. There are many drawbacks to this approach. First, the system is equivalent to  $2n + k$  first order differential equations—i.e., 14 first order coupled equations in the case of the Snakeboard. Second, when eliminating the Lagrange multipliers, we do not have a relationship, such as Eq. (3), which readily shows the effect of shape changes on robot motion. We now present an alternate approach that makes use of the inherent structure found in problems of locomotion.

#### 4 The Mechanics of Locomotion

The concept of conservation of linear and angular momentum is well known. We revisit the basis for this theory in a geometric setting, as this will lead to a new result of great use for locomotion analysis.

If the robot's initial body fixed frame position is denoted by  $h$  (e.g.  $h$  is a homogeneous transformation matrix), and it is displaced by an amount  $g$ , then its final position is  $gh$ . This displacement can be thought

of as a map  $L_g : G \rightarrow G$  given by  $L_g(h) = gh$ , and is termed a *left translation*. The left translation induces a *left action* of  $G$  on  $Q$ .

**Definition:** A *left action* of a Lie group  $G$  on a manifold  $Q$  is a map  $\Phi : G \times Q \rightarrow Q$  such that: (1)  $\Phi(e, q) = q$  for all  $q \in Q$ , and  $e$  the identity element of  $G$ ; and (2)  $\Phi(h, \Phi(g, q)) = \Phi(hg, q)$  for every  $g, h \in G$  and  $q \in Q$ . The left action can be viewed as a map from  $Q$  into  $Q$ , with the element  $g \in G$  held fixed. Notationally,  $\Phi_g : Q \rightarrow Q$  is given by  $(s, r) \mapsto (\Phi(g, s), r)$ . The *lifted action*, which describes the effect of  $\Phi_g$  on velocity vectors in  $TQ$ , is the linear map,  $D_q\Phi_g : T_qQ \rightarrow T_qQ$ .

Recall the division of the configuration space,  $Q = G \times M$ . Such a configuration space is termed a *trivial principal fiber bundle*.

**Definition:** Let  $M$  be a manifold and  $G$  a Lie group. A *trivial principal fiber bundle* with base  $M$  and structure group  $G$  consists of the manifold  $Q = G \times M$  together with the free left action of  $G$  on  $Q$  given by left translation:  $\Phi_g(s, r) = (gs, r)$  for  $r \in M$  and  $g, s \in G$ . Given a point  $(s, r) \in G \times M = Q$ , we define the natural projections  $\pi_1 : Q \rightarrow G : (s, r) \mapsto s$  and  $\pi_2 : Q \rightarrow M : (s, r) \mapsto r$ .

We say that  $Q$  is a *fiber bundle* with fibers  $G$  and base space  $M$ .  $Q$  is "trivial" because the product structure is global, and it is a "principal" bundle because the fiber is a Lie group. The additional structure arising from the Lie group component (which is common to *all* locomotion systems) is very important for the ensuing developments.

**Example #2 (cont'd).** The snakeboard's configuration space is  $Q = SE(2) \times (\mathcal{S}^1 \times \mathcal{S}^1 \times \mathcal{S}^1)$ , and a configuration is denoted  $q = (x, y, \theta, \psi, \phi_b, \phi_f)$ . The action is the left action of  $SE(2)$  on itself. Given  $g = (a_1, a_2, \alpha) \in SE(2)$ , the action and lifted action are:

$$\Phi_g(q) = \begin{pmatrix} x \cos \alpha - y \sin \alpha + a_1 \\ x \sin \alpha + y \cos \alpha + a_2 \\ \theta + \alpha \\ \psi \\ \phi_b \\ \phi_f \end{pmatrix} \quad (6)$$

$$D_q\Phi_g(v_q) = \begin{pmatrix} v_x \cos \alpha - v_y \sin \alpha \\ v_x \sin \alpha + v_y \cos \alpha \\ v_\theta \\ v_\psi \\ v_b \\ v_f \end{pmatrix} \quad (7)$$

where  $v_q = (v_x, v_y, v_\theta, v_\psi, v_b, v_f)$ .

Associated with a Lie group,  $G$ , is its Lie algebra, denoted  $\mathfrak{g}$ . The Lie algebra can be identified with  $T_e G$  and locally generates  $G$  via the exponential mapping,  $\exp : \mathfrak{g} \rightarrow G$  (see [1]). The exponential mapping also associates with each  $\xi \in \mathfrak{g}$  a vector field on  $G$ , and by extension on  $Q = G \times M$ , called the *infinitesimal generator*,  $\xi_Q$ , given by

$$\xi_Q(q) = \frac{d}{ds}(\Phi(\exp(s\xi), q))|_{s=0}. \quad (8)$$

Each infinitesimal generator is tangent to the fiber, and the set of all such vectors at  $q \in Q$  forms the *vertical* subspace of  $T_q Q$ ,

$$V_q Q = \{\xi_Q(q) \in T_q Q \mid \xi \in \mathfrak{g}\}. \quad (9)$$

That is, a vector  $v_q \in V_q Q$  represents a net velocity of the body with respect to an inertial frame, such that  $v_q = (v_g, 0)$  with  $v_g \in T_g G$ .

**Example #2 (cont'd):** The Lie algebra for  $SE(2)$  is denoted  $se(2)$ , and the relationship between an element,  $\xi = (a_1, a_2, \alpha) \in se(2)$ , and the corresponding infinitesimal generator is

$$\begin{aligned} \xi_Q(x, y, \theta, \psi, \phi_b, \phi_f) \\ = (a_1 - y\alpha, a_2 + x\alpha, \alpha, 0, 0, 0). \end{aligned} \quad (10)$$

The vertical subspace is given trivially by  $TG \times 0$ :

$$\begin{aligned} V_q Q &= \{(v_q, w_q) \in T_{\pi_1(q)} G \times T_{\pi_2(q)} M \mid w_q = 0\} \\ &= \text{span}\left\{\frac{\partial}{\partial x}, \frac{\partial}{\partial y}, \frac{\partial}{\partial \theta}\right\}. \end{aligned} \quad (11)$$

## 4.1 Mechanics with Symmetries

Conservation laws naturally arise when a Lagrangian remains invariant under the action of a Lie group, as stated in Noether's theorem [1]:

**Theorem:** Let  $L(q, \dot{q})$  be a Lagrangian which is invariant under the action of a Lie group,  $G$ , (i.e.,  $L(\Phi_g(q), D_q \Phi_g v_q) = L(q, v_q) \forall g \in G$ , for all  $v_q \in T_q Q$ ). Then, for all curves  $c(t) : [a, b] \rightarrow Q$  satisfying Lagrange's equations:

$$\frac{d}{dt} \left\langle \frac{\partial L}{\partial \dot{q}}(\dot{c}(t)); \xi_Q(c(t)) \right\rangle = 0 \quad (12)$$

for all  $\xi \in \mathfrak{g}$ . Equivalently,  $\dot{p} = 0$ , where  $p = \langle \frac{\partial L}{\partial \dot{q}}; \xi_Q \rangle$  is the *generalized momentum*.

The invariance of the Lagrangian with respect to a Lie group is termed a *symmetry*. When  $G$  is  $SE(2)$  or  $SE(3)$ , Noether's theorem is equivalent to conservation of linear and angular momentum. However, undulatory locomotion relies upon an interaction with

the environment. Unfortunately, conservation laws *may not be preserved* in the presence of constraints. The next section describes a recent extension to the classical theory that combines symmetries with constraints.

## 4.2 Symmetries and Constraints

Let the *constraint distribution* be the set of all velocities that satisfy the kinematic constraints):

$$\mathcal{D}_q = \{v_q \in T_q Q \mid \omega_j^i v_q^j = 0, i = 1, \dots, k\}. \quad (13)$$

Let  $\mathcal{S}$  denote the *constrained fiber distribution*, which is given at each  $q$  by the intersection of the constraint distribution,  $\mathcal{D}_q$ , with the vertical subspace,  $V_q Q$ :

$$\mathcal{S}_q = \mathcal{D}_q \cap V_q Q. \quad (14)$$

If the constraints act *vertically* (i.e.  $\mathcal{S}$  is nonempty), then we have the following [3]:

**Proposition #1:** Let  $L$  and  $\mathcal{D}$  define a constrained system on  $Q = G \times M$  whose Lagrangian is  $G$ -invariant. If  $c(t)$  is a curve which satisfies the Lagrange-d'Alembert equations (Eq. 2) for a system with nonholonomic constraints (Eq. 1), then the following *generalized momentum equation* holds for all vector fields,  $\xi_Q^c \in \mathcal{S}$ :

$$\frac{d}{dt} p^c = \frac{\partial L}{\partial \dot{q}^i} \left( \frac{d}{dt} [\xi^c(c(t))] \right)_Q^i + \tau_i \left( \xi^c(c(t)) \right)_Q^i \quad (15)$$

where

$$p^c = \frac{\partial L}{\partial \dot{q}^i} (\xi^c(c(t)))_Q^i \quad (16)$$

is the *constrained*, or *nonholonomic*, momentum. The generalized momentum equation can always be factored into the quadratic form [30]:  $\dot{p} = \frac{1}{2} \dot{r}^T \sigma_{\dot{r}\dot{r}}(r) \dot{r} + p^T \sigma_{pr}(r) \dot{r} + \frac{1}{2} p^T \sigma_{pp}(r) p$ .

Prop. #1 states that in the presence of constraints, momentum-like quantities exist, but may not be conserved. Eq. (15), determines how these momentum-like quantities evolve. *The non-conservation of these momentum-like quantities is the key to dynamic undulatory locomotion* (and many other forms of locomotion). It describes why the snakeboard can build up momentum, even though no external forces act on the system.

**Example #2 (cont'd).** The snakeboard Lagrangian, Eq. (4), is invariant with respect to an  $SE(2)$  group action. The wheel constraints of Eq. (5) can be expressed as a constraint distribution:

$$\mathcal{D}_q = \text{span}\left\{a \frac{\partial}{\partial x} + b \frac{\partial}{\partial y} + c \frac{\partial}{\partial \theta}, \frac{\partial}{\partial \psi}, \frac{\partial}{\partial \phi_b}, \frac{\partial}{\partial \phi_f}\right\}, \quad (17)$$

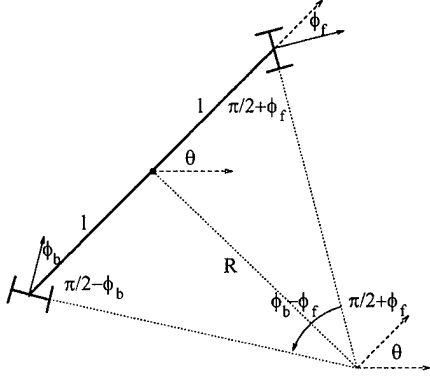


Figure 4: The snakeboard's instantaneous center of rotation

where

$$\begin{aligned}
 a &= -l[\cos \phi_b \cos(\phi_f + \theta) + \cos \phi_f \cos(\phi_b + \theta)] \\
 b &= -l[\cos \phi_b \sin(\phi_f + \theta) + \cos \phi_f \sin(\phi_b + \theta)] \\
 c &= \sin(\phi_b - \phi_f).
 \end{aligned} \tag{18}$$

The vertical distribution was defined in Eq. (11), and the constrained fiber distribution is:  $\mathcal{S}_q = \mathcal{D}_q \cap V_q Q = \text{span}\{a \frac{\partial}{\partial x} + b \frac{\partial}{\partial y} + c \frac{\partial}{\partial \theta}\}$ .  $\mathcal{S}_q$  corresponds to instantaneous rotations of the snakeboard about the point where the two wheel axes intersect (Fig. 4). The *nonholonomic momentum* of Eq. (16) is:

$$\begin{aligned}
 p^c &= \langle \frac{\partial L}{\partial \dot{q}}, (\xi^c)_Q(q) \rangle \\
 &= (mR^2 + \hat{J}_c) \dot{\theta} + J_r c \dot{\psi} + J_w c (\dot{\phi}_b + \dot{\phi}_f),
 \end{aligned} \tag{19}$$

$R$  is the radius from the instantaneous center of rotation to the snakeboard's center of mass. Thus,  $p^c$  corresponds to the snakeboard's angular momentum about the instantaneous center of rotation. If the front and back wheels were fixed, this momentum would be conserved, as the fixed wheels provide a holonomic constraint of rotation about the fixed center. However, since the constraints are variable, the snakeboard's momentum can be altered by internal forces.

### 4.3 The Connection and Locomotion

We now introduce a key concept in the theory of principal fiber bundles which also plays an important role in locomotion analysis.

**Definition 1** A connection is an assignment of a horizontal subspace,  $H_q Q \subset T_q Q$ , for each point  $q \in Q$  such that  $H_q Q$  depends smoothly on  $q$  and:

- (1)  $T_q Q = V_q Q \oplus H_q Q$ ;
- (2)  $D_q \Phi_g H_q Q = H_{g \cdot q} Q$ .

Condition (1) implies that  $T_q Q$  can everywhere be divided into a vertical subspace,  $V_q Q$ , and a complementary (but not necessarily orthogonal) subspace,  $H_q Q$ , which is termed the horizontal space. Connections are useful because of the following fact. The horizontal subspace defined by the connection is everywhere isomorphic to the tangent space of the base:  $H_q Q \simeq T_{\pi_2(q)} M$ . The *horizontal lift* is the isomorphism which maps vectors in  $T_{\pi_2(q)} M$  to the corresponding lifted vectors in  $H_q Q \subset T_q Q$ . The horizontal lift determines the relationship between motion in the base space (i.e., tangent vectors in  $T_{\pi_2(q)} M$ ) and motion in the total space,  $Q$ , where locomotion is effected. We will choose  $H_q Q$  to encode the action of the constraints. Hence, *the connection will determine how internal shape changes create net robot motion*.

A connection on  $Q$  is alternatively described by a Lie algebra-valued one-form termed the *connection form*. That is, the connection form is a mapping  $A(q) : T_q Q \rightarrow \mathfrak{g}$ , where  $\mathfrak{g}$  is the Lie algebra of  $G$ . The connection form has the properties

$$(1) A(q) \cdot \xi_Q = \xi \text{ for } \xi \in \mathfrak{g},$$

$$(2) A(\Phi_g q) \cdot D_q \Phi_g \dot{q} = Ad_g A(q) \cdot \dot{q}.$$

Condition (1) implies that  $A(q)$  takes infinitesimal generators to their associated Lie algebra elements. The connection form vanishes on horizontal vectors:  $A(q) \dot{q} = 0$  for all  $\dot{q} \in H_q Q$ . Hence,  $H_q Q$  can alternatively be defined as the set of tangent vectors upon which the connection form vanishes.

For the case of mixed constraints, we will define  $H_q Q$  as  $H_q Q = \{v_q \in T_q Q \mid v_q \in \mathcal{D}_q \text{ and } \langle\langle v_q, w_q \rangle\rangle = 0 \forall w_q \in \mathcal{S}\}$ , where  $\langle\langle \cdot, \cdot \rangle\rangle$  is the inner product with respect to the kinetic energy metric. In other words, horizontal vectors satisfy both the kinematic constraints and the symmetry constraints. If  $\dot{q}$  is a horizontal velocity vector, with  $\dot{q} = (\dot{g}, \dot{r})$ , then it can be shown that the connection form can be expressed as:

$$g^{-1} \dot{g} = -A(r) \dot{r} + I(r)^{-1} p, \tag{20}$$

where  $A(r)$  is the "local form" of the connection, and  $I(r)$  is the *locked inertia tensor*.  $I(r)$  describes the total inertia of the system when all joints are frozen at configuration  $r$ . The connection plays the most central role in the mechanics of locomotion, since it determine the robot's motion (note that  $g^{-1} \dot{g}$  is the velocity of the robot's reference frame) as the combination of built-up momentum,  $p$  and internal shape changes,  $\dot{r}$ .

In summary, we have reduced the system of  $n$  second order ODE's with  $k$  first order constraints (Eqs.

(1), (2)) to a system of  $\sigma = \dim(G)$  first order constraints (the connection form),  $\sigma - k$  first order generalized momentum equations, and  $\dim(M)$  second order equations on the base space (termed the "reduced" dynamics):

$$\begin{aligned} g^{-1}\dot{g} &= -A(r)\dot{r} + I(r)^{-1}p, \\ \dot{p} &= \frac{1}{2}\dot{r}^T \sigma_{\dot{r}\dot{r}}(r)\dot{r} + p^T \sigma_{p\dot{r}}(r)\dot{r} + \frac{1}{2}p^T \sigma_{pp}(r)p, \\ M(r)\ddot{r} &= -C(r, \dot{r}) + N(r, \dot{r}, p) + \tau. \end{aligned} \quad (21)$$

The reduced dynamics are not important for understanding locomotion, though they may be important in the synthesis of a controller, as they describe the dynamics of the mechanism's internal shape deformations. Thus, the equations which are important for understanding locomotion are reduced to two first order equations that make explicit how shape changes lead to robot motion.

**Example (concl):** The snakeboard's connection and generalized momentum equation take the form of Eq. (21), where:

$$A(r) = I^{-1}(r)f(r) \quad (22)$$

$$I^{-1}(r) = \frac{1}{W(r)} \cdot \begin{bmatrix} 2l \cos \phi_b \cos \phi_f \\ l \sin(\phi_b + \phi_f) \\ -\sin(\phi_b - \phi_f) \end{bmatrix} \quad (23)$$

$$\dot{p}^c = \frac{1}{2} \frac{d}{dt} \left( \log \left( (mR^2 + \hat{J})c \right) \right) \cdot (p^c - f(r)\dot{r}) + \dot{f}(r)\dot{r}, \quad (24)$$

where  $W(r) = \hat{J} \sin^2(\phi_b - \phi_f) - ml^2 \sin^2(\phi_b + \phi_f) - 4ml^2 \cos^2 \phi_b \cos^2 \phi_f$ , and  $f(r) = \sin(\phi_b - \phi_f)(J_r, J_w, J_w)$ . This approach leads to a very concise formulation of the important dynamical relationships that govern the snakeboard's movement.

We now briefly consider special cases of these equations in order to show that Eq. (21) includes many previously studied problems as a special case.

**Kinematic Constraints.** With a sufficient number of kinematic constraints, the group symmetries are annihilated, and the system's motion is fully determined by the constraints. In this *principal kinematic case*, the connection takes the form:

$$g^{-1}\dot{g} = A(r)\dot{r}. \quad (25)$$

which we term a *kinematic connection*. Many wheeled vehicles, such as Example #1, fall into this category, and have been extensively studied in the literature on nonholonomic systems.

**Symmetry Constraints.** There are no kinematic constraints in the cases of falling cats or platform divers. Yet, these systems have inherent Lagrangian

symmetries, and therefore conserved momenta. In these cases, the connection and generalized momentum equations take the form:

$$\begin{aligned} g^{-1}\dot{g} &= A(r)\dot{r} + I^{-1}(r)\mu \\ \dot{\mu} &= 0. \end{aligned} \quad (26)$$

$\mu$  is the generalized momenta, and is constant. If  $\mu = 0$ , these equations take the form of Eq. (25).

## 5 Controllability

A locomotion mechanism is *controllable* if given any initial configuration  $q_i$  and final configuration  $q_f$ , there exists an admissible control law which drives the system from  $q_i$  to  $q_f$ . Controllability is an important issue for several reasons. First, when designing a locomoting robot, we would like to know if it can reach all possible positions in its environment. Second, Section 6 will briefly discuss the relationship between "gaits" and certain controllability calculations. Surprisingly, *controllability can be determined via the connection and the generalized momentum equation*. This result further illustrates the usefulness of these equations as tools for locomotion analysis.

To express the system of equations in the standard control form of  $\dot{z} = f(z) + h_1(z)u_1 + \dots + h_m(z)u_m$ , we must dynamically extend the control inputs by redefining them as higher derivatives of the input variables. Equivalently, the accelerations are the control inputs. Letting  $v = \dot{u}$ , and using  $z = (g, p, r, \dot{r})$ , the connection and generalized momentum equations can be put in the standard control form with:

$$f(z) = \begin{bmatrix} g(-A\dot{r} + I(r)^{-1}p) \\ \frac{1}{2}\dot{r}^T \sigma_{\dot{r}\dot{r}} + p^T \sigma_{p\dot{r}} + \frac{1}{2}p^T \sigma_{pp} \\ \dot{r} \\ 0 \end{bmatrix} \quad (27)$$

$$h_i(z) = [0 \ 0 \ 0 \ e_i^T]^T \quad (28)$$

where  $e_i$  is the  $m$ -vector ( $m = \dim M$ ) with a "1" in the  $i^{\text{th}}$  row and "0" otherwise.

There are two commonly used notions of control—*accessibility* and *controllability* (see [14] for descriptions of these concepts). For nonlinear systems, *small-time local controllability* is the closest that we can come to our intuitive notion of controllability. Accessibility is determined by computing the *accessibility distribution*. Let  $\Delta_0 = \text{span}\{f, h_1, \dots, h_m\}$ , and iteratively define the distributions

$$\Delta_k = \Delta_{k-1} + \text{span}\{[X, Y] \mid X, Y \in \Delta_{k-1}\}. \quad (29)$$

This nondecreasing sequence of distributions terminates at some  $k_f$  under certain regularity conditions.

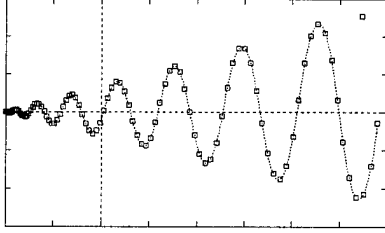


Figure 5: Center of mass position (drive gait)

$\Delta_{k_f}$  is the accessibility distribution. A system is *accessible* if  $\dim \Delta_{k_f} = \dim T_z N$  for all  $z \in N$ . It can be shown [30] that the system in Eq. (27) is small-time locally controllable from equilibrium points if: (1) the accessibility distribution is full rank; and (2)  $\sigma_{\dot{r}}$  is an onto map; and (3)  $(\sigma_{\dot{r}})_{ii} = 0$  for  $i = 1, \dots, m$ .

While these controllability results are useful for the analysis of locomotion systems, the next section shows that there is a more fundamental reason to undertake this controllability analysis.

## 6 Geometric Phases and Gaits

The snakeboard moves by coupling periodic motions of the rotor and wheel axles. For example, Fig. 5 shows the position of the snakeboard’s center of mass versus time for the case in which the rotor and wheel axles oscillate with the same frequency (which we term the “drive gait”), the case in which the axles oscillate at twice the frequency of the rotor (the “rotate gait,” as the robot essentially rotates in place), and the case in which the axles oscillates three times for every two oscillations of the rotor (the “parallel parking gait”). Intuitively, a gait is a cyclic pattern of internal shape changes that results in a net robot displacement. Different gaits correspond to different cyclic input patterns. In the principal kinematic case, the net displacement of the mechanism that arises from periodic inputs is the *geometric phase*, or holonomy, associated with the connection. In the mixed case, the net displacement is a combination of the geometric phase and the *dynamic phase*.

We do not yet have a complete geometric understanding of the notion of gaits. However, we have found that different gaits can be associated with the brackets that are computed for the controllability test in Section 5. For the snakeboard, let  $\alpha_\phi = [h_\phi, f]$ —the bracket between the control vector field associated with the turning of the wheel axles and the drift vector field. Similarly, let  $\alpha_\psi = [h_\psi, f]$ . These two brackets loosely correspond to an integration of the control torques to produce velocity controls. For the

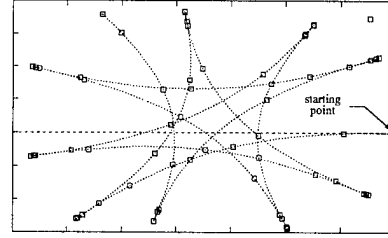


Figure 6: Center of mass position (rotate gait)

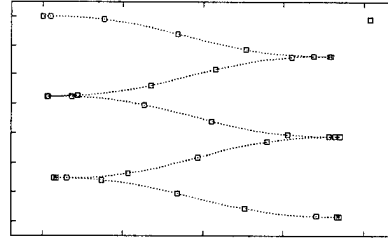


Figure 7: Position of the center of mass for the “parallel parking gait”

drive gait, which employs a 1-to-1 frequency ratio of rotor and axle oscillations, the bracket  $[\alpha_\phi, \alpha_\psi]$  has non-zero terms only in the  $\dot{x}$  component, which corresponds to forward motion of the vehicle. Similarly, the rotate gait employs a 2-to-1 frequency ratio of the axle and rotor oscillations. The two-level bracket  $[\alpha_\phi, [\alpha_\phi, \alpha_\psi]]$ , where  $\alpha_\phi$  appears two times, has non-zero terms only in the  $\dot{\theta}$  direction, and thus corresponds to the rotation gait. Thus, the controllability analysis of Section 5 has been useful in identifying candidate gaits.

## 7 The Kinematic Snake Model

To demonstrate the utility of this approach, let’s consider a “snake-like” system which is modeled after Hirose’s Active Cord Mechanism (ACM-III) [12]. Fig. 8 shows a schematic of three segments of the mechanism. Each segment is connected to adjacent segments through an actively controlled revolute joint. The axles of the passive wheel assemblies can be rotated about a vertical axis. Let’s first consider a mechanism comprised of two segments. There are two wheel constraints which constrain the 3-dimensional Lie group of robot motion. The kinematic constraints do not fully specify the system’s motion in  $SE(2)$ . This is a system with *mixed* constraints, where the third constraint is based on a generalized momentum.

With three segments, there are the same number of constraints as there are dimensions of  $SE(2)$ , and so the kinematic constraints define a *principal kinematic*

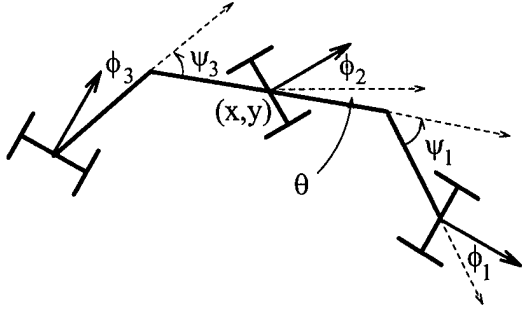


Figure 8: A model for the kinematic snake

*connection.* In the case of additional body segments, the first three segments define the robot's motion in  $SE(2)$ , and the wheel constraints of the additional segments are used as governing equations for the motion of these segments. This system will have a "following" behavior, in which the lead segments define the path to be traced, and the additional segments follow this lead. In real snakes, additional segments can provide greater stability or can be used for more complicated maneuvers, such as crossing over gaps.

For the three segment device in Fig. 8, let  $(x, y, \theta) \in SE(2)$  denote the center of the middle segment, while the wheel angles of segments 1, 2, and 3 are denoted  $(\phi_1, \phi_2, \phi_3) \in S^1 \times S^1 \times S^1$ . The relative orientation of segment 1 with respect to segment 2, and segment 2 with respect to segment 3, is denoted by  $(\psi_1, \psi_3) \in S^1 \times S^1$ . Each no-slip wheel constraint takes the form:

$$(-\sin \tilde{\phi}_i, \cos \tilde{\phi}_i) \cdot \begin{bmatrix} \dot{\tilde{x}}_i \\ \dot{\tilde{y}}_i \end{bmatrix} = 0, \quad (30)$$

where  $\tilde{\phi}_i$  is the absolute angle of the  $i^{th}$  wheel, and  $(\tilde{x}_i, \tilde{y}_i)$  is the Cartesian positioning of the center of rotation for the  $i^{th}$  wheel. The kinematic constraint equations can be expressed in the form:

$$W(r)T_g L_g^{-1} \dot{g} = \Gamma(r)\dot{r}. \quad (31)$$

Since the constraints are  $G$ -invariant, the kernel of these constraints defines a connection on  $Q = SE(2) \times S^1 \times S^1 \times S^1 \times S^1 \times S^1$ . We can invert the constraint equations directly to write the local form of the connection one-form as

$$\xi = g^{-1} \dot{g} = -\mathcal{A}(r)\dot{r}, \quad (32)$$

where  $\xi \in \mathfrak{g}$  and:

$$\begin{aligned} \xi^1 &= -\frac{l^2 \cos \phi_2}{\det W} [\psi_1 \cos \phi_1 (\cos(\phi_3 - \psi_3) + \cos \phi_3) \\ &\quad + \psi_3 \cos \phi_3 (\cos(\phi_1 + \psi_1) + \cos \phi_1)] \\ \xi^2 &= \xi^1 \tan \phi_2 \\ \xi^3 &= \frac{l}{\det W} [\psi_1 \cos \phi_1 \sin(\phi_3 + \psi_3 - \phi_2) \\ &\quad - \psi_3 \cos \phi_3 \sin(\phi_1 - \psi_1 - \phi_2)], \end{aligned} \quad (33)$$

with

$$\det W = l[\sin(\phi_1 - \psi_1 - \phi_2)(\cos(\phi_3 + \psi_3) + \cos \phi_3) + \sin(\phi_3 + \psi_3 - \phi_2)(\cos(\phi_1 - \psi_1) + \cos \phi_1)]. \quad (34)$$

Suppose that we add a fourth segment. Let  $\phi_4$  and  $\psi_4$  denote the angles of the wheels and the body segment, respectively. Letting  $\tilde{\phi}_4 = \phi_4 + \psi_3 + \psi_4 + \theta$ , the no-slip kinematic wheel constraint is:

$$\begin{aligned} &-\sin \tilde{\phi}_4 \dot{x} + \cos \tilde{\phi}_4 \dot{y} - l(\cos(\phi_4 + \psi_3 + \psi_4) \\ &+ 2 \cos(\phi_4 + \psi_4) + \cos \phi_4) \dot{\theta} \\ &- l(2 \cos(\phi_4 + \psi_4) + \cos \phi_4) \dot{\psi}_3 = l \cos \phi_4 \dot{\psi}_4. \end{aligned} \quad (35)$$

We have added two degrees of freedom ( $\phi_4$  and  $\psi_4$ ) and one kinematic constraint (Eq. (35)). Both  $\phi_4$  and  $\psi_4$  are controlled, but we must also satisfy the constraint. This is done by choosing to control the wheel angle, while inverting Eq. (35) to establish a governing equation for  $\psi_4$ :

$$\begin{aligned} \dot{\psi}_4 &= \frac{1}{\cos \phi_4} \left( \frac{1}{l} (-\sin \tilde{\phi}_4^e \xi^1 + \cos \tilde{\phi}_4^e \xi^2) \right. \\ &\quad \left. - (\cos \tilde{\phi}_4^e + 2 \cos(\phi_4 + \psi_4) + \cos \phi_4) \xi^3 \right. \\ &\quad \left. - (2 \cos(\phi_4 + \psi_4) + \cos \phi_4) \dot{\psi}_3 \right), \end{aligned}$$

where  $\tilde{\phi}_4^e = \phi_4 + \psi_3 + \psi_4$ , i.e.,  $\tilde{\phi}_4|_{g=e} = \tilde{\phi}_4|_{\theta=0}$ . Notice that  $\dot{\psi}_4$  depends upon a term with  $\cos \phi_4$  in the denominator. We assume that the wheels cannot pivot to an angle of  $\pm \frac{\pi}{2}$ . Repeating this process, we can add additional segments so as to guarantee that each following segment satisfies all of the constraints. It is always possible to arrange the additional constraint equations in the form:

$$\begin{aligned} B(\phi_4, \dots, \phi_k) \begin{bmatrix} \dot{\phi}_4 \\ \vdots \\ \dot{\phi}_k \end{bmatrix} \\ = C(\phi_4, \dots, \phi_k, \psi_3, \dots, \psi_k) \begin{bmatrix} \xi \\ \psi_3 \end{bmatrix} \end{aligned}$$

where  $k$  is the total number of body segments. The matrix  $B$  is lower triangular, with determinant

$$\det(B) = \prod_{j=4}^k l \cos \phi_j,$$

and is always invertible.

## 7.1 Locomotive Gaits

We now consider the undulatory gait employed by many snakes. Hirose described this gait as being



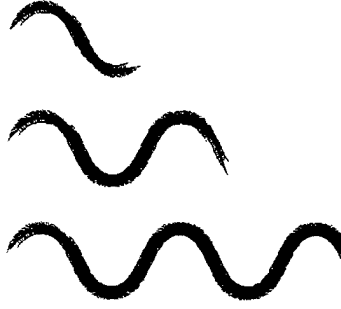


Figure 9: A trace of the serpentine mode

closest to a “serpenoid” curve, and we show below that one of the gaits generated by our approach is strikingly similar to the serpenoid curve. We also present two other gaits not normally seen in nature, but which arise for the particular model we are using. Like the snakeboard, the gaits are based on integrally related frequencies of the shape inputs. The ratios relate the frequency of bending of the inter-segment angle,  $\psi_i$ , with the frequency of the wheel rotations,  $\phi_i$ .

**The “serpentine” gait:** Forward motion can be created by using a 1:1 frequency ratio. For this, we use periodic control inputs of the form:

$$\phi_i = a_i^\phi \sin(\omega_i^\phi t + p_i^\phi), \quad (36)$$

where similar values for  $\psi_i$  will be superscripted with a  $\psi$ . The serpentine gait can be demonstrated using the values

$$\begin{aligned} a_1^\phi = a_3^\phi = 0.2 = -a_2^\phi, & & a_1^\psi = a_3^\psi = 0.6, \\ \omega_1^\phi = \omega_2^\phi = \omega_3^\phi = 1, & & \omega_1^\psi = \omega_3^\psi = 1, \end{aligned} \quad (37)$$

where the length from the wheel base to inter-segment pivot point is 0.1m (hence a segment has length 0.2m). For the phasing, we use a traveling wave down the length of the snake (by incrementing the phase of the wheels at each segment), while forcing the inter-segment angle,  $\psi_i$ , to move  $90^\circ$  out of phase with their corresponding wheels. Thus, for the simulation shown in Fig. 9, the phases are given by

$$\begin{aligned} p_1^\phi = -\frac{\pi}{16}, & & p_2^\phi = 0, & & p_3^\phi = \frac{\pi}{16}, \\ p_1^\psi = \frac{7\pi}{16}, & & p_3^\psi = \frac{9\pi}{16}. \end{aligned} \quad (38)$$

Each of the wheel angles differs by  $\frac{\pi}{16}$ , while the joint angles are  $\frac{\pi}{2}$  out of phase with their respective wheel angles. A trace of the motion appears in Fig. 9.

By varying the magnitudes of the wheel angles (or the inter-segment joint angles), slightly different patterns of locomotion are found to occur. Fig. 10

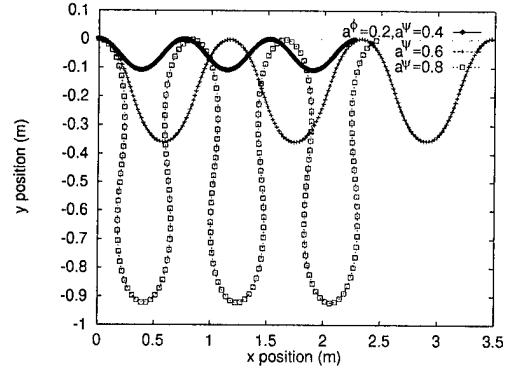


Figure 10: Three different serpentine gait shapes

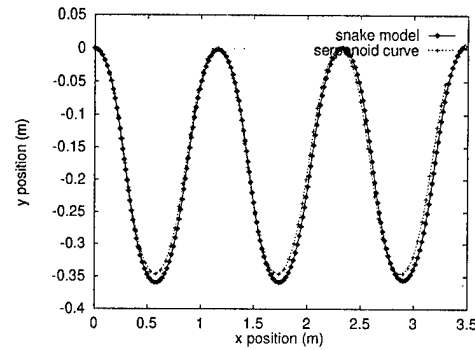


Figure 11: A comparison of the kinematic snake model versus the serpenoid curve

shows the resultant gaits for three different values of  $a_1^\psi = a_3^\psi = a^\psi$ . Each of these simulated gaits is run for the same length of time, which indicates that certain parameter values will result in a greater distance being traveled.

Let us compare this motion with the serpenoid curve proposed by Hirose [11]. The serpenoid curve has the parameterization:

$$\begin{aligned} \dot{x} &= \cos(\alpha \sin(\beta s)) \\ \dot{y} &= -\sin(\alpha \sin(\beta s)). \end{aligned} \quad (39)$$

The parameters  $\alpha$  and  $\beta$  can be chosen such that the serpenoid curve will closely match any of the serpentine patterns generated using the 1:1 gait. An example is shown in Fig. 11, with  $\alpha = 0.85$  and  $\beta = \frac{23\pi}{16} \simeq 4.52\text{rad}$ .

The serpentine gait seems to work well when additional segments are added using the methods described in above. Fig. 12 shows the trace of a 5-segment snake robot model.

**The “rotate” gait:** There are at least two gaits that lead to a net rotation. The first gait is reminiscent of a “three-point turn.” For the gait shown in Fig. 13, the frequency ratio is 2:1, with the parameters used

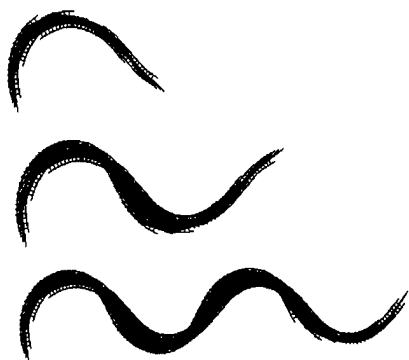


Figure 12: Traces of the 5-link kinematic snake

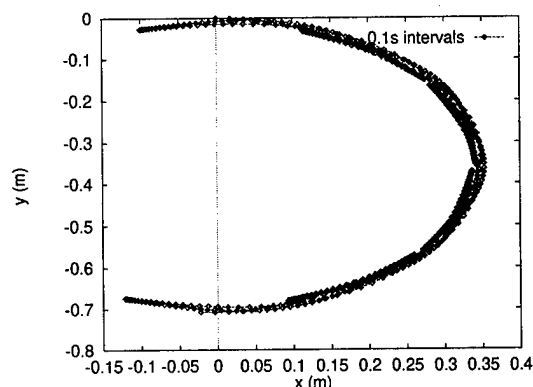


Figure 13: A trace of the 2:1 gait

being the same as above, except that  $\omega_1^\psi = \omega_2^\psi = 2$  and all joint magnitudes,  $a_1^\phi, \dots, a_2^\psi$  are 0.4 and 0.5, respectively. The 1:2 rotate gait, with the parameters  $a^\phi = \frac{\pi}{4}$  and  $a^\psi = \frac{3\pi}{8}$ , is shown in Fig. 14, which plots the variation of  $\theta$  with respect to time. The  $(x, y)$  position of this segment moves only very insignificantly during this gait.

## 8 Extension of the Approach

Preliminary work has shown that many of the basic concepts presented in this paper can be extended to

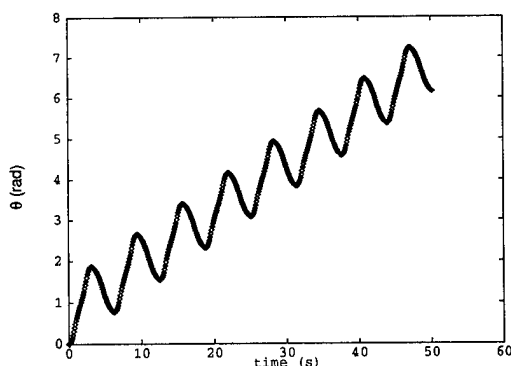


Figure 14: A trace of the angle  $\theta$  for the 1:2 gait

a large class of locomotory systems, since virtually all forms of locomotion use some type of constraint to generate propulsive forces. There are two basic efforts required to extend this theory to other classes of locomotors. First, not all constraints that arise in different locomotion systems will take the form of Eq. (1). Hence, the derivations that lead to Proposition #1 must be reworked for different types of constraints. Similarly, the form of the connection will also be modified. Second, the theory must be extended to handle the intermittent constraints that arise in legged locomotion. This extension is considered in more detail in Refs. [10, ?]. During the motion of a legged robot, a leg will repeatedly make and break contact with the supporting terrain. This nonsmooth interaction with the environment can be modeled as a system that evolves on a configuration manifold,  $Q$ , with a boundary,  $\partial Q$ . The boundary corresponds to those states where the leg contacts the terrain. There will be two sets of dynamical equations, and hence two connections. One set will describe the system when it is in contact with the terrain, while one will describe the system when the leg is not in contact. While our dynamics methodology extends easily to this case, the issue of controllability becomes more complex. We have recently developed a controllability test for driftless systems on a manifold with boundary. Omitting a few technicalities, it can be shown that if  $\overline{\Delta}_Q^c$  is the involutive closure of the accessibility distribution of the control system operating in  $Q$ , and if  $\overline{\Delta}_{\partial Q}^c$  is the involutive closure of the accessibility distribution of the control system operating in  $\partial Q$ , then the system is locally controllable if  $\overline{\Delta}_Q^c(q) + \overline{\Delta}_{\partial Q}^c(q) = T_q Q$  for all  $q \in U$ , where  $U$  is a neighborhood of  $q \in \partial Q$ . In general, a legged mechanism will have more than one leg. The configuration space of such a system will be a *stratified set*. For multi-legged robots, the individual strata physically correspond to states in which different numbers of legs are in contact with the ground. This is the generalization of the problem of control on a manifold with boundary.

## 9 Discussion and Conclusions

Undulatory locomotors have no thrusters, tracks, or legs to generate motion. Instead, motion is generated by a coupling of internal shape changes to external constraints. This paper focused on a class of systems with nonholonomic kinematic constraints, which includes not only the snakeboard and Hirose's ACM, but also any undulatory robotic system that uses wheels to provide motion constraints. Also, many of the snake and worm-like systems discussed in [7]

can be analyzed using these techniques. A key observation is that the constraints inherent in undulatory systems provide the means to determine motion as a function of internal shape change. When kinematic constraints do not uniquely determine a robot's motion, dynamic symmetries provide the additional constraints. We used the formal language of connections on principle bundles because the connection encompasses much of the information which is essential to locomotion. Using these tools, we can parameterize the dynamics in terms of physically meaningful variables of momenta, internal shape, and robot reference frame motion. The connection also leads directly to the analysis of locomotor controllability. We believe that this framework will ultimately form the basis of a unifying theory for robotic locomotion.

## References

- [1] Ralph Abraham and Jerrold Marsden. *Foundations of Mechanics*. Addison-Wesley, Reading, MA, second edition, 1978.
- [2] A. M. Bloch, M. Reyhanoglu, and N. H. McClamroch. Control and stabilization of nonholonomic dynamic systems. *IEEE Trans. on Aut. Control*, 37(11):1746–1757, 1992.
- [3] A.M. Bloch, P. S. Krishnaprasad, J.E. Marsden, and R.M. Murray. Nonholonomic mechanical systems and symmetry. Technical report, California Institute of Technology, Pasadena, CA, 1994. Submitted to the *Archive for Rational Mechanics and Analysis*. Available via <http://avalon.caltech.edu/cds/reports/cds94-013.ps>.
- [4] J.W. Burdick, J. Radford, and G.S. Chirikjian. A 'sidewinding' locomotion gait for hyper-redundant robots. *Advanced Robotics*, 9(3):195–216, 1995.
- [5] C. I. Byrnes and A. Isidori. On the attitude stabilization of rigid spacecraft. *Automatica*, 27:87–95, 1991.
- [6] C. Canudas de Wit and O. J. Sørvalen. Exponential stabilization of mobile robots with nonholonomic constraints. *IEEE Trans. on Aut. Control*, 37(11):1791–1797, Nov 1992.
- [7] G.S. Chirikjian and J.W. Burdick. The kinematics of hyper-redundant locomotion. *IEEE Trans. on Robotics and Automation*, 11(6):781–793, 1995.
- [8] S. Hirose et. al. Titan III: A quadruped walking vehicle. In *2<sup>nd</sup> Int. Symp. on Robotics Research*, Tokyo, Japan, 1985.
- [9] J. Furusho and A. Sano. Sensor-based control of a nine-link biped. *Int. J. Robotics Research*, 9(2):83–98, April 1990.
- [10] Bill Goodwine and Joel Burdick. Trajectory generation for legged robots. In *Proc. IEEE Int. Conf. on Robotics and Automation*, Albuquerque, NM, May 1997.
- [11] S. Hirose. *Biologically Inspired Robots: Snake-like Locomotors and Manipulators*. Oxford Univ. Press, Oxford, 1993.
- [12] S. Hirose and A. Morishima. Design and control of a mobile robot with an articulated body. *The Int. J. of Robotics Research*, 9(2):99–114, 1990.
- [13] S. Hirose and Y. Umetani. Kinematic control of active cord mechanism with tactile sensors. In *Proc. 2<sup>nd</sup> Int. CISM-IFT Symp. on Theory and Practice of Robots and Manipulators*, pages 241–252, 1976.
- [14] A. Isidori. *Nonlinear Control Systems: an Introduction*. Springer-Verlag, Berlin, 1989.
- [15] Shuuji Kajita and Kazuo Tani. Study of dynamic biped locomotion on rugged terrain. In *Proc. IEEE Int. Conf. Robotics and Automation*, pages 1405–1411, Sacramento, CA, April 1991.
- [16] S. Kelly and R. Murray. Geometric phases and robotic locomotion. *J. Robotic Systems*, 12(6):417–431, June 1995.
- [17] D. Koditschek and M. Buhler. Analysis of a simplified hopping robot. *Int. J. of Robotics Research*, 10(6):587–605, Dec. 1991.
- [18] P.S. Krishnaprasad and D.P. Tsakiris. G-snakes: Nonholonomic kinematic chains on Lie groups. In *Proc. 33<sup>rd</sup> IEEE Conf. on Decision and Control*, Lake Buena Vista, FL, Dec 1994.
- [19] J-P. Laumond, P. Jacobs, M. Taix, and R. M. Murray. A motion planner for nonholonomic mobile robots. *IEEE Trans. on Robotics and Automation*, 10(5):577–593, 1994.
- [20] A. Lewis, J. Ostrowski, R. Murray, and J. Burdick. Nonholonomic mechanics and locomotion: the snakeboard example. In *Proc. IEEE Int. Conf. on Robotics and Automation*, pages 2391–2397, San Diego, CA, 1994.

- [21] T. McGeer. Passive dynamic walking. *Int. J. of Robotics Research*, 9(2):62–82, April. 1990.
- [22] R. T. M'Closkey and R. M. Murray. Exponential stabilization of driftless nonlinear control systems using homogeneous feedback. Technical Report CIT/CDS 95-012, California Inst. of Technology, 1995.
- [23] R.T. M'Closkey and J.W. Burdick. On the periodic motions of a hopping robot with vertical and forward motion. *Int. J. of Robotics Research*, 12(3):197–218, June 1993.
- [24] H. Miura and I. Shimoyama. Dynamic walk of a biped. *Int. J. of Robotics Research*, 3(2):60–74, 1984.
- [25] R. Montgomery. Isoholonomic problems and some applications. *Comm. in Math. Physics*, 128(3):565–592, 1990.
- [26] R. M. Murray and S. S. Sastry. Nonholonomic motion planning: Steering using sinusoids. *IEEE Trans. on Automatic Control*, 38(5):700–716, 1993.
- [27] R.M. Murray and S.S. Sastry. Steering non-holonomic systems in chained form. In *Proc. 31st IEEE Conf. on Decision and Control*, pages 1121–1126, Brighton, England, December 1991.
- [28] Y. Nakamura and R. Mukherjee. Exploiting nonholonomic redundancy of free-flying space robots. *IEEE Trans. on Robotics and Automation*, 9(4):499–506, August 1993.
- [29] J. Ostrowski, J. Burdick, A. Lewis, and R. Murray. The mechanics of undulatory locomotion: the mixed dynamic and kinematic case. In *Proc. IEEE Int. Conf. on Robotics and Automation*, Nagoya, Japan, May 1995.
- [30] J.P. Ostrowski. *The Mechanics and Control of Undulatory Robotic Locomotion*. PhD thesis, California Inst. of Technology, Pasadena, CA, Sept. 1995.
- [31] M.H. Raibert. *Legged Robots that Balance*. MIT Press, 1986.
- [32] P. Rouchon, M. Fliess, J. Levine, and P. Martin. Flatness and motion planning: the car with  $n$  trailers. In *Proc. European Control Conference*, pages 1518–1522, 1992.
- [33] Alfred Shapere and Frank Wilczek. Geometry of self-propulsion at low Reynolds number. *J. Fluid Mechanics*, 198:557–585, January 1989.
- [34] S.M. Song. and K.J. Waldron. *Machines that walk: the Adaptive Suspension Vehicle*. MIT Press, 1989.
- [35] A.F. Vakakis, J. W. Burdick, and T.K. Caughey. An interesting attractor in the dynamics of a hopping robot. *Int. J. of Robotics Research*, 10(6):606–618, Dec. 1991.
- [36] Gregory C. Walsh and S. Shankar Sastry. On re-orienting linked rigid bodies using internal motions. *IEEE Trans. on Robotics and Automation*, pages 139–146, 1995.



## CHAPTER 10: SOME ANALYTICAL AND SIMULATION RESULTS

Mine Warfare is supported by distributed modeling and simulation techniques. Such simulations underlie much of what is called C4I -- Command, Control, Communications, Computers and Intelligence. These simulations and analyses provide meaning to the data that comes from sensors from spatially distributed platforms.

Professor Barr, of the U.S. Military Academy, described a Cadet-prepared simulation of minefield penetration and its application to compare the effectiveness of Intelligent Wide Area Mines (IWAMs) with other standard types of landmines. Dr. Frank Herr of the Office of Naval Research, who was also Session Chair, presented a summary of his ONR team's research with remote sensors for use in coastal and inshore operations. Dr. Nicholas Chotiros presented his research findings on the effectiveness and limitations of acoustic imaging -- detection and classification -- of buried targets. Professor Rex Buddenberg of the Naval Postgraduate School presented a synopsis of research with clear C4I applications, demonstrating the rapid delivery of photographic images of mine-like objects taken from an MH-53 acoustic search directly to the on-scene customer, thus eliminating the high bandwidth transmission of a complete video of the entire search track. Finally, John Benedict Jr. of Johns Hopkins University's Applied Physics Laboratory presented an analytical paper filled with data-rich operational insights on the effectiveness of countermeasures against standard marine bottom mines and expected new ones. He also covered the effectiveness of different modes of minefield reconnaissance and marking. Mr. Benedict's excellent summary overview, "Pervasive Technical Issues Related to Organic Mine Countermeasures," appears in Chapter 7.

The papers in this Chapter are but samples of a major, ongoing effort in Mine Warfare modeling, simulation and analysis.



# EVALUATION OF INTELLIGENT MINEFIELDS

John A. Marin

and

Donald R. Barr

Department of Systems Engineering

West Point, NY 10996

## Abstract

The mission of the Wide Area Munition (WAM) is to increase the effectiveness of minefields, slow clearing operations by attacking enemy vehicles, and disrupt enemy formations and command and control forward of most direct fire systems. The intelligent minefield integrates new mine systems into an optimized, logistically efficient, autonomous anti-armor barrier by allowing WAMs to communicate and provide real-time tracking of potential targets. The purpose of this work was to design a system that enables a user to evaluate different characteristics of an intelligent minefield, such as effective detection range, effective communication range, and the probability of hit for a WAM. Other characteristics that could be evaluated include the change in information provided by minefield sensors (measured using a decrease in entropy), delay time caused by a particular minefield, the effectiveness of a particular minefield pattern, and the cost-effectiveness of a given minefield. The evaluation system is written in Visual Basic and operates on a PC. The user is given full control of the program, to include designing a minefield pattern by placing mines on the screen through the use of a mouse and associated icons. The evaluation program simulates vehicles entering the minefield from different locations, allows for numerous runs, and calculates appropriate statistics including confidence intervals.

**Key Words:** minefield, mines, munitions, simulation, Visual Basic, anti-armor, entropy, graphical user interface, sensors, effectiveness.



## Introduction

The purpose of a minefield is to provide counter-mobility against the enemy by fixing, turning, killing, or delaying the enemy. Land minefields, the focus of this paper, can be composed of pressure detonated “conventional” mines (CMs), Wide Area Munitions (WAMs), Intelligent Munitions (IWAMs) or Field Artillery Scatterable Mines (FASCAMs). The WAM is an autonomous system that employs acoustic and seismic sensors to track vehicles and launches a top-attack sub-munition to defeat enemy armored vehicles. Proposed uses of the WAM include increasing the effectiveness of minefields, slowing clearing operations by attacking enemy breaching vehicles, and disrupting enemy formations and command and control forward of most direct fire systems []. The intelligent minefield integrates new mine systems, such as WAMs, into an organized, logistically efficient, autonomous anti-armor barrier by allowing WAMs to communicate and provide real-time tracking of potential targets [].

We consider the problem of determining optimal, or at least good, deployment patterns for minefields designed to achieve delay of enemy armored units. Deployment includes numbers of mines, mixes of mine types and patterns of lay-down of the mines. It seemed apparent simulation would provide an appropriate means of examining this problem. However, existing combat simulations we evaluated proved unsuitable for evaluating intelligent minefields. For example, the Janus Combat model, version 5.X, only models mines as pressure detonated devices and does not permit mines to communicate []. Likewise the Modular Semi-Automated Forces (ModSAF) model only allows the user to change parameters such as ammunition, fuse, surface, emplacement, and pattern [], but ModSAF does not currently model an intelligent minefield.

Thus in order to assess a range of intelligent minefield deployments, we constructed a high resolution, interactive, stochastically based simulation to facilitate evaluation of minefields composed of combinations of the four previously described types of mines. The simulation, written in Visual Basic, was designed as part of an undergraduate capstone engineering course in the Systems Engineering Department at the U.S. Military Academy. This simulation was jointly

developed by the authors and a team of cadets and it was applied in the course to measure the performance of several minefield designs, including variations of mixes of types of mines, and placement patterns of mines.

## **Background**

### ***Definition of Terms***

*Conventional mines* - Pressure detonated mines that exhibit no tracking or communication capabilities.

*Wide Area Munition (WAM)* - Autonomous munition that detects, classifies, tracks, and launches a top-attack sub-munition.

*Intelligent Wide Area Munition (IWAM)* - IWAMs have the capability to communicate with other IWAMs and to transmit information to a tactical Operations Center (TOC) via “gateway” devices. A communicating pair of IWAMs has an increased probability of hit (over an autonomous WAM) in the intersection of the pair’s lethality coverage areas. *Field Artillery*

*Scatterable Mines (FASCAM)* - Pressure detonated mines delivered by Field Artillery systems.

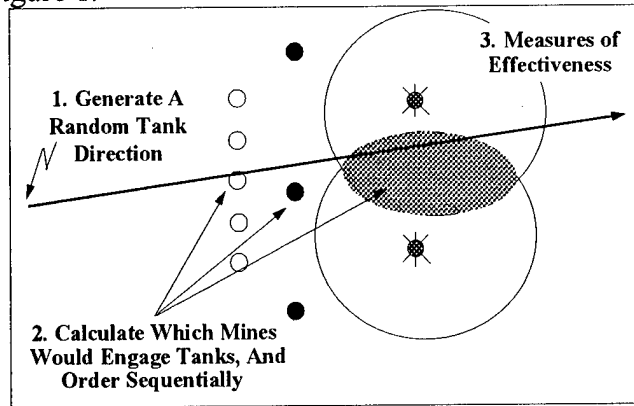
*Paths* - Routes taken by enemy vehicles through the minefield. We currently assume the paths are straight lines.

*Lethality Function* - Bivariate function whose values represent the probability an attacked target will be hit. We consider combinations of two lethality models: the “cookie-cutter” model and the “Carlton” function. The cookie-cutter function is a constant within a given region (usually a circle centered on the engaging mine) and is zero outside that region. The Carlton function is a scaled bivariate normal density function within a given circle about the engaging mine, and is zero outside that circle [].

### ***Overview of the Model***

The simulation generates random paths through a user defined minefield configuration. Each path represents the trajectory of a predetermined number of enemy armored vehicles (“tanks”) through the minefield area, traveling generally from west to east. For each path, the order in

which the mines would engage members of the enemy platoon is calculated. Monte Carlo routines, described below, assess the outcome of each engagement, and data supporting calculation of several measures of effectiveness (MOE) are stored. The general layout of this process is depicted in Figure 1.



**Figure 1.** Open circles depict conventional mines, solid disks represent WAMs, and starred discs represent IWAMs. The shaded region is where IWAMs have enhanced hit probability.

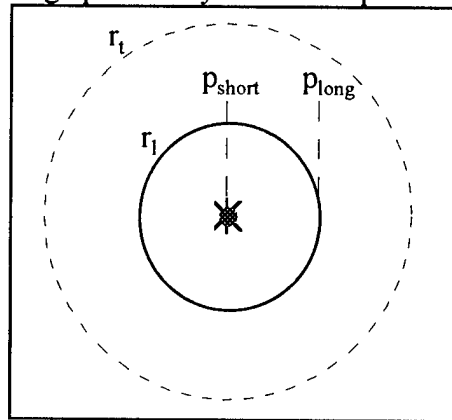
### *Model Assumptions*

While some Intelligent Minefield concepts separate sensors from mines [2], for the initial implementation of this simulation it was assumed sensors and mines are collocated on the same platform. Future versions of the simulation will separate the sensor and mine functions. Tanks move in a wedge formation with a pre-determined width. The initial setting for tank width is 10 meters, however, the simulation may be modified to use any desired tank width. This parameter is relevant in that it relates to the “lethal radius” of conventional mines. Tanks will continue to move in a wedge formation until a predetermined number of mines or munitions have been exploded. Once this threshold is exceeded, it is assumed the remaining tanks in the platoon leave the minefield by retracing their entry path.

The probability of hit of a tank in the attacking platoon is determined as follows:

Conventional Mines - the “lethal radius” (distance within which the mine will attack a tank within the platoon) is a user specified number of “tank widths” (i.e the number of tanks in a platoon), and the probability of hit within this circle is assumed to be unity.

WAMs - there are two circles, one of radius  $r_t$  representing the region in which the WAM can sense and track potential targets, and one of radius  $r_l < r_t$  representing its lethal radius. Within the circle of lethal radius, a WAM is assumed to have hit probability determined by a Carlton lethality circle [5]. The Carlton lethality function requires the user to supply a short and long range probability of hit as depicted below in Figure 2.



**Figure 2.** Short, long range probabilities, and tracking and lethal radii for WAM or IWAM.

IWAMs - the model for WAMs is modified so there is constant probability of hit within the intersection of the lethal circles of communicating IWAM pairs. If a path intersects such a region, it is assumed a tank of the platoon is attacked within the region, i.e., the IWAMs are intelligent enough to determine whether a path intersects the overlap region, and if so, to arbitrate the attack so as to take advantage of the improved tracking accuracy within the overlap region. If an IWAM is not communicating with another IWAM tracking the same target, it has the lethality characteristics of a WAM.

FASCAM - for individual munitions the model for conventional mines is used. The model plays ballistic distribution of the FASCAM artillery rounds, and assumes a bivariate normal distribution of munitions carried by each FASCAM round.

WAM and IWAM munitions only fire at the closest distance between the approaching tank platoon and the munition.

## Intelligent Minefield Simulation System

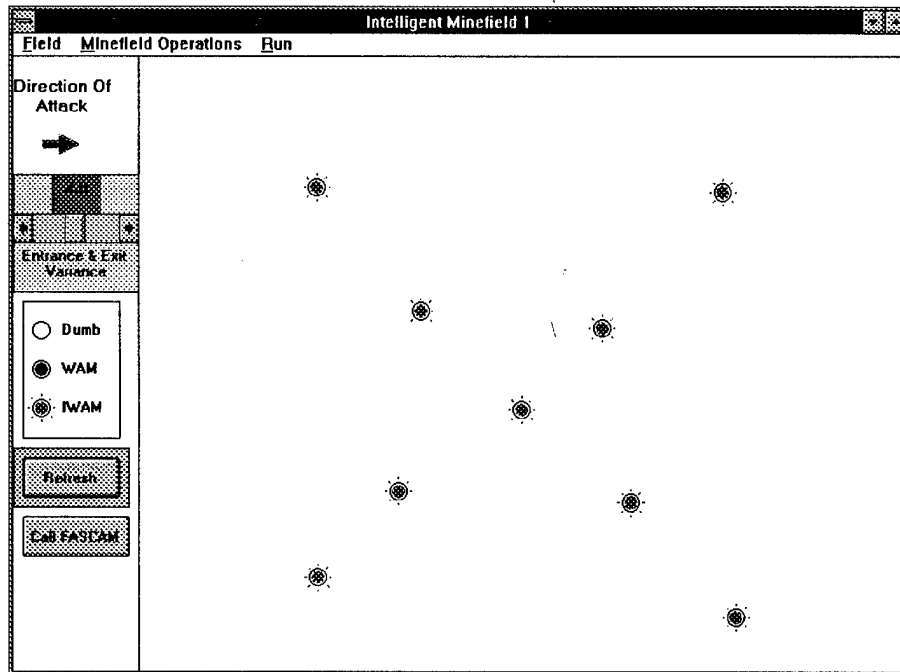
### *Graphical User Interface and Controls*

The intelligent minefield simulation system is a PC based program written in Visual Basic and consists of over 1500 lines of code. The user has complete control over a variety of mine parameters as described in Table 1 below.

	Conventional	WAM	IWAM	FASCAM
Number of Mines	X	X	X	X
Lethal Radius	X	X	X	X
PHit (Short Range)	X	X	X	X
PHit (Intersection)			X	
Phit (Long Range)		X	X	
P(Kill   Hit )	X	X	X	X
Detection Range		X	X	
Tracking Range		X	X	

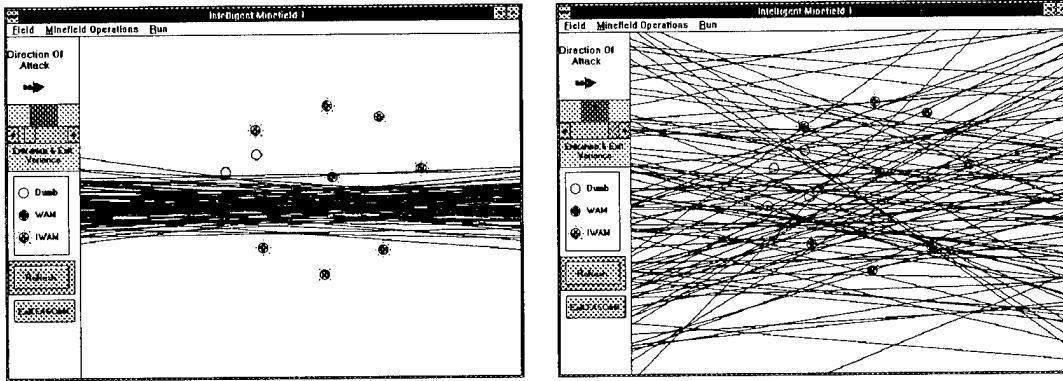
**Table 1:** User-controlled parameters for the minefield simulation.

A sophisticated graphical user interface (GUI) allows the user to create different minefield configurations by simply clicking on an icon and moving the icon to the desired location. This windows-based interface allows the user to designate the numbers of mines of the various types, and to position the mines into any pattern desired using a mouse. The user can also control the number of iterations of the simulation and the variation in paths through the minefield area. Additional visual aids allow the user to display the killing radius of WAMs and IWAMs, as well as the communication range of IWAMs. The user also has the option of displaying a grid to locate mines, designate a random number seed, and a save function that saves minefield data for future reference. The minefield area is a square 1.5 Km on a side, oriented with sides parallel to north-south (vertical, on the windows display) and west-east (horizontal) directions. A depiction of the basic minefield screen is shown at Figure 3.



**Figure 3.** Basic minefield screen depicting 9 IWAMs in an X pattern.

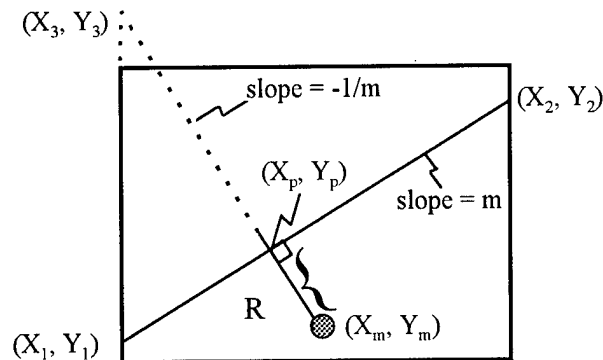
Platoons of tanks are simulated as vectors along paths through the minefield. Each path is simulated by generating a pair of values representing the ordinate (nothing) of the path's entry- and outbound-points. A path's entry point is on the line along the west border of the area; its outbound point is on the line along the east border of the area. The heights of the points on these lines are determined by a pair of generated normal or uniform deviates, as designated by the user. The means of these normal distributions correspond to the center of the respective borders, and the common variance is controlled by the user. By selecting small variance, the user roughly can model a minefield area in a valley or blocking a roadway. By choosing a larger variance, the user can model a minefield in an open area or desert terrain. The patterns of paths generated with set values of the variance parameter is illustrated in Figure 4 which shows realizations of 100 paths for two selected values of the variance with a normal distribution.



**Figure 4.** Path patterns with low and high variance settings .

### ***Evaluation Algorithm***

The evaluation algorithm, explained in the following paragraph, measures the distance for a mine to a given path and calculates if the path is within the lethal radius of the mine. Thus, given  $(X_1, Y_1)$  is the entry point of the path,  $(X_2, Y_2)$  is the exit point of the path, and  $(X_m, Y_m)$  is a given mine coordinate, the perpendicular (minimum) distance from the mine to the path, depicted below in Figure 5, is computed as follows:



**Figure 5.** Path-mine geometry.

It is easily seen the coordinate of the closest approach of the path to the mine is

$$(X_p, Y_p) = \left( \frac{(Y_3 - Y_1)}{(m + 1/m)}, -\frac{1}{m} \cdot \frac{(Y_3 - Y_1)}{(m + 1/m)} + Y_3 \right),$$

(1)

so the perpendicular distance from the mine to the path,  $R$ , is computed using the Pythagorean

Theorem,

$$R = \sqrt{(X_p - X_m)^2 + (Y_p - Y_m)^2}$$

(2)

The algorithm used to evaluate a minefield is displayed below in Figure 6. The user sets initial minefield parameters, including those listed in Table 1 (step 1). Mine characteristics such as location, type, probability of hit, are stored in a two dimensional array designated as  $\mathbf{m}(i, j)$ , where  $i$  represents the characteristic and  $j$  is a mine index ranging from 1 to the total number of mines,  $n$ , that uniquely identifies each mine. The loop in steps 3 through 16 generates a path, and evaluates the effectiveness of the minefield against a platoon of tanks moving along that path. After a path is generated, the algorithm calculates which mines would engage the tank (step 6), and sorts the engagements based on the order with which the tanks would reach the mines (step 11). If a tank moves within the effective radius for a given mine, then a Monte Carlo process is used to determine the effects of the mine at the closest approach distance (step 13).

The algorithm continues to assess the results of mine and tank interactions until the platoon successfully traverses the minefield, a tank is killed, or until a user supplied number engagements has been exceeded, in which case the platoon is assumed to have stopped until a path through the minefield is cleared by breaching equipment. At this point, another iteration of the simulation is generated (if appropriate) or the algorithm stops and appropriate statistics computed.

Let  $\mathbf{m}(i, j)$  = two dimensional array such that  $i$  represents mine specifications and  $j$  represents a unique mine of type  $I$

cnt, k be integer counters

max\_paths = user specified number of paths

max\_atck = user specified stopping criteria

tot\_mines = total number of mines

Random() be a function that returns an appropriate random number

Min\_Dist() be a function the computes the distance from a mine to a path

Sort() sorting routine

Hit\_Prob be a function that computes the probability of a hit and kill

Entropy() be a function the evaluates the information gained by a given mine

Print\_Results be a function that displays measures of effectiveness

Initialize parameter values

Initialize  $\mathbf{m}(i, j)$

WHILE ((cnt  $\leq$  max\_paths) AND (atck  $<$  max\_atck)) DO

Y1  $\leftarrow$  Random(); Y2  $\leftarrow$  Random()

FOR k=1 to tot\_mines DO

R  $\leftarrow$  Min\_Dist( $\mathbf{m}(i, k)$  X1, Y1, X2, Y2, XM, YM))



```

IF R < m(L, k) THEN
    m(L, k) = 1 /* sets lethal (L) value of array to 1 */
    Lethal_Mines ← Lethal_Mines + 1
END FOR
Sort(m(L, k), XM) For All m(L, k) = 1 /* sorts only Lethal mines */
WHILE (k ≤ lethal_mines) AND (atck < max_atck ))DO
    IF Hit_Prob(m(H, k)) < Random() atck ← atck + 1 /* H is prob(hit) */
    Entropy(m(E, k))
END WHILE
END WHILE
Print_Results()

```

**Figure 6.** Pseudo-code illustrating the logic of the minefield simulation.

### *Measures of Effectiveness (MOE)*

#### **Traditional MOE**

**Percent Transversals.** If an enemy platoon receives fewer than a preset number of engagements by any of the mines considered, then it is assumed to have traversed the minefield. This is based on an assumption that a certain number of engagements will cause the platoon to retreat out of the minefield. The simulation records the number of iterations that result in fewer than the threshold number of engagements, and this is used to calculate the percentage of the platoon attacks that were “successful” in traversing the minefield, and the variance of the success.

**Number of Engagements.** The total number of times the minefield engaged the enemy platoon is determined for each iteration (i.e., for each generated path), and the mean and variance over iterations is calculated.

**Number of Hits.** The total number of times the minefield hit an enemy tank in each iteration is counted, and the mean and variance over iterations is calculated.

**Number of Kills.** Similar to (3) for kills, rather than hits.

**Kills by Munition Type.** The simulation records the number of kills by each type of mine or munition, within each iteration. The mean and variance over iterations is calculated.

**Penetration Distance.** The distance the enemy platoon progresses into (or through) the minefield

is determined for each iteration, and the mean and variance over iterations is calculated. This distance is measured along the path segment within the minefield.

### **Information Evaluation (Entropy)**

We measure the lack of information the Blue commander has about the Red tank platoon using the concept of entropy, as introduced by Shannon [1]. If a system can be in states 1, 2, ...  $n$  with probabilities  $p_1, p_2, \dots, p_n$ , the entropy of the system is defined below in equation 3:

$$e = -\sum p_i \ln(p_i) \quad (3)$$

where the summation extends over states having positive probabilities. If the states are equally likely (the distribution is uniform over the states), the  $p$ 's are equal to  $1/n$ , and the entropy expression simplifies to  $e = \ln(n)$ . For a continuous model, with terrain regions in place of the states, we proceed in a similar fashion. In this case, for a uniform model,  $n$  is proportional to the area,  $A$ , of the region, so the entropy is proportional to  $\ln(A)$ . If data are obtained indicating the enemy tanks are within a sub-region of area  $B < A$ , then the entropy has decreased to  $\ln(B)$ , and the information gain is taken to be  $\ln(A) - \ln(B)$ .

Assuming a minefield is placed as a result of some form of intelligence as to the enemy's likely avenues of approach, it follows that initially only the general area of the enemy's position is known. We model this by assuming the location is known at the beginning of each iteration only up to a uniform distribution over a large initial area,  $A = 3 \cdot 1500^2$ , which represents the area of three consecutive 1500 X 1500 minefields. Since the IWAMs in the minefield convey to the TOC information about the enemy's movements or presence, the Blue commander may gain information about the enemy tanks. We model this as a uniform distribution over a subset of area  $B$  of the original region. This means the entropy may decrease because more information on the possible location of the enemy is known. Using this logic, the simulation evaluates entropy at five classifications of level of uncertainty about the enemy platoon for each iteration, and the mean and variance of information gain over iterations is computed. The posterior information classifications are:

1. No detection by IWAMs of enemy activity within sensor range. In this case,  $B = 3 \cdot 15002$ , so information gain is zero.
2. IWAM senses conventional or WAM detonations. The reduced area is  $B = \pi \cdot rs^2$ , where  $rs$  is the sensor range of the IWAM. This represents the IWAM's ability to sense the explosion of another munition.
3. IWAM senses tanks traversing the minefield. Then  $B = \pi \cdot rt^2$ , where  $rt$  is the tracking range of the IWAM.
4. Two communicating IWAMs simultaneously track the tank platoon. In this case,  $B = 0.5 \pi \cdot rt^2$ . This crudely represents the average intersection area with tracking by two communicating IWAMs.
5. IWAM fires upon the enemy platoon as it attempts to traverse the minefield. Then  $B = \pi \cdot rl^2$ , where  $rl$  is IWAMs maximum lethal range.

Multiple combinations of these events can occur within any one simulation iteration. The simulation saves only the smallest value of  $B$  per iteration, because this represents the most accurate fixing of the enemy platoon's location. The simulation calculates and records the entropy decrease,  $\ln(A) - \ln(B)$  for each iteration and computes the mean and variance of information gain over iterations.

### Model Verification

In addition to standard methods of model verification, such as running a simple scenarios with known outputs, we verified the model using an analytical approach. The probability a single tank survives a minefield of known width,  $P(S)$ , given  $L$  is the average distance a tank must travel through the field,  $d$  is the effective influence diameter of a mine,  $A$  is the area of the field, and  $n$  is the number of mines, is

$$P(S) = 1 - \left( \frac{Ld}{A} \right)^n \quad (4)$$

(see [] for a discussion of this model).

Table 2 shows a comparison of results of the simulation using conventional mines distributed in a random pattern with results obtained using the analytic model given in Equation 1. For each

given number of mines shown in the table, the simulation was repeated 100 times, each with 1,000 iterations. Note the survivability of tanks estimated by the simulation and predicted by the simulation agree, in all cases, to at least the 99.5% level of significance. It is clear the simulation is generating appropriate values of P(S) for these cases.

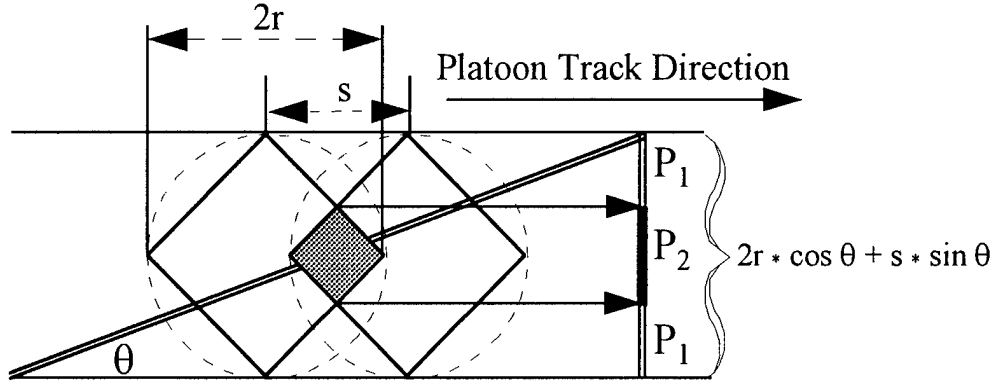
# Mines	P(S) Simulation	P(S) Predicted	t-Statistic
10	.9556	.9569	.00631
12	.9485	.9484	-.00045
14	.9394	.9401	.00293
16	.9304	.9319	.00589
18	.9233	.9237	.00150
20	.9165	.9155	-.00361

**Table 2.** Comparison of simulation and analytical survival probabilities.

### Optimal Separation Between IWAMs

It seems plausible there might be an interesting trade-off between total coverage of a communicating pair of IWAMs, and the enhanced hit probability in the region of overlap of their lethal radii,  $r$ . That is, as separation distance,  $s$ , increases from  $0$  to  $2r$ , so that the lethal area circles move from total overlap toward no overlap, the area covered by the pair increases (tending to make engagement probability larger) but the overlap area decreases (tending to make probability of hit, given engagement, smaller). For what value of  $s$  is probability of kill maximized?

A crude approximation of the intersecting circles was developed using intersecting diamonds and assuming a two-valued lethality function: hit probability is  $p1$  over areas of single coverage and is  $p2$  over double coverage (intersection) areas. Modeling circles of lethality by diamond-shaped regions allows simple linear expressions for hit probability as functions of the separation distance,  $s$ , for each encounter geometry of the path with the region. We let  $\theta$  denote the angle the tank platoon track makes with the line through the centers of the diamonds. The geometric situation for the case  $0 \leq \theta \leq \pi/4$  is shown in Figure 7.



**Figure 7.** Approximation of communicating IWAM regions using diamonds.

We consider the projection of the coverage area along the direction of the platoon path upon a line normal to the track direction, as shown in Figure 7. For  $0 \leq \theta \leq \pi/4$ , the length of the projection is  $2r \cos(\theta) + s \sin(\theta)$ . The length of the projection of the double coverage region is

$2(r - s/2) \cos(\theta)$ . Thus, for  $0 \leq \theta \leq \pi/4$ , the hit probability is proportional to

$$p_1 \left( 2r \cos(\theta) + s \sin(\theta) - 2\left(r - \frac{s}{2}\right) \cos(\theta) \right) + p_2 \left( 2\left(r - \frac{s}{2}\right) \cos(\theta) \right)$$

$$= p_1 s (\cos(\theta) + \sin(\theta)) + p_2 (2r - s) \cos(\theta) .$$

(5)

Similarly, for  $\pi/4 \leq \theta \leq \pi/2$ , the hit probability is proportional to

$$p_1 \cdot 2s \sin(\theta) + p_2 (2r - s) \sin(\theta).$$

(6)

Assuming the encounter angle,  $\Theta$ , is uniformly distributed over  $(0, \pi/2)$ , the expected hit probability,  $p_H$ , is

$$p_H = p_1 s \left[ \int_0^{\pi/4} \cos(\theta) + \sin(\theta) d\theta + 2 \int_{\pi/4}^{\pi/2} \sin(\theta) d\theta \right] + p_2 (2r - s) \left[ \int_0^{\pi/4} \cos(\theta) d\theta + \int_{\pi/4}^{\pi/2} \sin(\theta) d\theta \right]$$

$$= p_1 s [1 + 2/\sqrt{2}] + p_2 (2r - s) 2/\sqrt{2} . \quad (7)$$

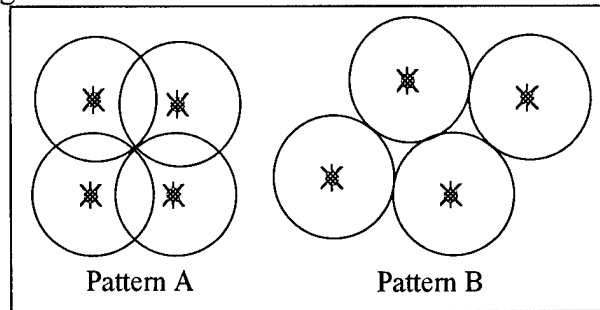
Since  $p_H$  is linear in  $s$ , it follows the optimal separation is either  $0$  or  $2r$  (i.e., total overlap or total separation), depending on whether the slope  $p_1(1 + 2/\sqrt{2}) - p_2(2/\sqrt{2})$  is negative or positive, respectively. In summary, to maximize hit probability, the crude geometric model suggests the separation  $s$  should be

$$s = 0, \text{ if } p_1/p_2 < 2/(2+\sqrt{2}) \approx .586;$$

$$s = 2r, \text{ otherwise.}$$

(8)

The result with the approximate geometric model suggests a similar situation holds for the circular model with the Carlton lethality function. This hypothesis is supported by experiments we conducted with the minefield simulation. We used 100 iterations of 1,000 paths each for the minefields depicted in Figure 8.



**Figure 8.** Overlap and Non-Overlapping lethal patterns for mine areas.

Table 3 provides results for experiments conducted at low, medium, and high path variances (low variance are paths concentrated through a narrow portion of the minefield), and different long range probabilities of hit (long range probability is a parameter required for the Carlton function). The values in Table 3 represent the probability one tank is engaged ( $pe$ ) and hit ( $ph$ ) by a mine. Note  $pe$  remained constant as the long range probability of hit changed since  $pe$  is not effected by a change in  $ph$ . However, since the non-overlapping minefield covered more total area than the overlapping minefield, the non-overlapping minefield exhibited a higher  $pe$ , and subsequent higher  $ph$  than the overlapping minefield. This result was true in all experiments except for the case of the low variance minefield, where paths were spatially concentrated.

	Probability (Long range)	Variance		
		Low	Medium	High
Overlap	.5	$pe = .995$ $ph = .850$	$pe = .786$ $ph = .656$	$pe = .642$ $ph = .530$
Overlap	.75	$pe = .995$ $ph = .873$	$pe = .789$ $ph = .668$	$pe = .643$ $ph = .532$

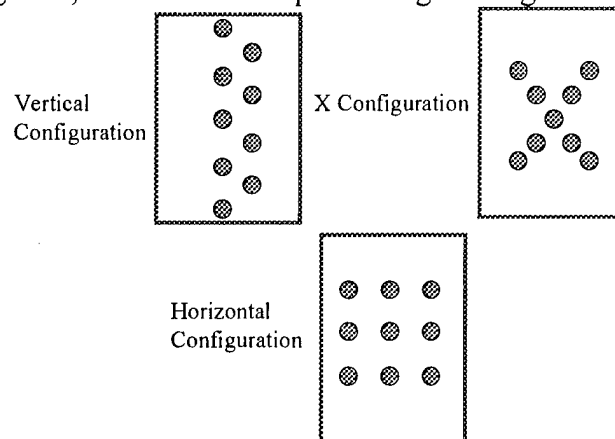
Overlap	1	pe = .994	pe = .787	pe = .640
		ph = .994	ph = .787	ph = .640
Non-Overlap	.5	pe = .995	pe = .811	pe = .738
		ph = .822	ph = .747	ph = .651

**Table 3:** Probability of Engagement (pe) and probability of hit (ph) for overlapping and non-overlapping minefields at different long range probabilities and variances.

Of course, if the tracking radii is much larger than the lethal radii, then mines should be positioned so the *lethal areas* do not intersect, but the *tracking areas* do intersect. In other words, the optimal situation is where mines are positioned as in Figure 6B above, and benefit from an overlapping tracking range.

### *Analysis of Minefield Patterns*

Another example of the type of analysis that can be conducted with the minefield simulation program is the evaluation of different minefield patterns. We constructed three minefield patterns as depicted below in Figure 9, and tested these patterns against high and low tank path variances.



**Figure 9.** Sample Minefield Patterns

Each type of configuration was implemented using both WAMs and IWAMs. The number of mines was varied for each configuration between 5, 9, and 13 mines. Based on the expected number of kills, the best minefield pattern was the horizontal configuration. Since at a low variance the majority of all trajectories must pass through the layers of the horizontal configuration, the horizontal pattern performed much better than the vertical or X pattern. At a

high variance, the horizontal pattern still performed the best, however, it was only slightly better than the vertical configuration.

Information gain results returned from IWAMs were also analyzed for the different patterns and paths. The best largest information gain for a high tank path variance results were for a vertical configuration because tanks enter and exit the minefield from greater locations, and the vertical minefield is more spread-out. For a low variance, the horizontal configuration was best at providing information about the enemy. An example of the information gain statistics collected from the model is displayed below in Table 4.

	High Variance			Low Variance		
	Vertical	Horizontal	X	Vertical	Horizontal	X
<b>5 mines</b>	7.516	7.810	6.8884	8.2598	9.387	9.6617
<b>9 mines</b>	9.194	8.072	8.3991	9.2893	9.3023	9.6874
<b>13 mines</b>	9.203	8.723	9.3517	9.2828	9.371	9.689

**Table 4.** Statistics on information gain for different minefield patterns and high or low tank path variance.

### Conclusion

We have introduced, implemented, verified, and validated a high resolution, interactive, stochastically based simulation that facilitates the evaluation an intelligent minefield. The simulation, written in Visual Basic, fills a need that is not satisfied by existing combat simulations. Results from an application of the model concerning the evaluation of minefield patterns, to include a theoretical assessment of the area of coverage for communicating IWAMS, is also presented.

The major contributions of the research include a new paradigm for modeling minefields, an efficient algorithm for assessing minefield effectiveness, and preliminary research addressing optimal minefield patterns. Future research includes refining the model by separating the sensor from the IWAM platform, allowing a tank path to change direction after a mine is detected and development of a mathematical model for optimal minefield coverage.



### *Acknowledgments*

*The authors would like to thank the U.S. Army Armament, Research, Development and Engineering Center (ARDEC) at Picatinny Arsenal, NJ, who sponsored this project. Also, we would like to recognize the contributions of Second Lieutenants Matthew Champion, Jonathan Darr, Paul Ferrigno, Kyle Towns and Mr. Hernan Ruiz, who did much of the preliminary work on this project during their senior year at the United States Military Academy.*

# Evaluation of AUV Search Tactics for Rapid Minefield Traversal using Analytic Simulation and a Virtual World

Don Brutzman, Bryan Brauns, Paul Fleischman,  
Tony Lesperance, Brian Roth and Forrest Young

Undersea Warfare Academic Group  
Code UW/Br, Naval Postgraduate School  
Monterey California 93943-5000 USA  
408.656.2149 voice, 408.656.3679 fax  
*brutzman@nps.navy.mil*

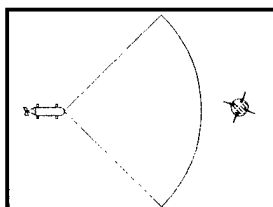
*<http://www.stl.nps.navy.mil/~auv/simulation/mcm96.ps>*

**Abstract.** Rapid and thorough minefield mapping is an essential prerequisite for an amphibious assault. An autonomous underwater vehicle (AUV) designed to search and map a shallow-water landing zone might be a major mine countermeasures (MCM) asset. In this paper we focus on evaluation of AUV tactics for searching a minefield. The NPS *Phoenix* AUV, analytic simulation techniques and an underwater virtual world are used to study and evaluate eight candidate search tactics (Figures 1 and 2).

Simulation provides a vital link between scientific advances, developmental cost savings, tactical flexibility and operational effectiveness. Tactical minefield search scenarios are evaluated based on requirements for conduct of MCM in a shallow-water landing zone. The simulated minefield is one kilometer squared (1 Km<sup>2</sup>), containing 10 moored submerged mines distributed in either random or barrier fields. The time limit placed on the search operation is five hours due to likely operational constraints. Operating parameters for the simulated AUV are based on present or achievable *Phoenix* capabilities.

A variety of search tactics are implemented and evaluated. Simulated searches are repeated until results converge within acceptable statistical confidence intervals. Evaluation of search tactic simulation results is based on two measures of effectiveness (MOEs): number of mines found and area searched. These two evaluation criteria correspond to partial minefield search.

Such MOEs are chosen because exhaustive search is not possible based on size of the minefield, limited AUV search speed and tactical time constraints. Finally all of the search tactics are automatically converted into executable scripts written in the AUV mission script command language. Playing back AUV execution of candidate tactics using an underwater virtual world allows visualization of each search. This new methodology provides quantitative and qualitative insight into tactical employment of AUVs in MCM operations.



**Figure 1.** Objective is AUV minefield search.



**Figure 2.** Tactical evaluation performed in virtual world.

## 1 Introduction and Motivation

The present objective of U.S. Navy mine countermeasure (MCM) forces is to reduce the threat posed by mines until crossing the beach becomes merely a “speed bump” for amphibious landing forces (Bottoms 95, 96). The need for rapid and thorough reconnaissance of the mine threat thus becomes an essential part of a successful amphibious assault. Additionally, in order to maintain overall tactical surprise by a battle group, only a relatively short period of time may be allotted to search and map potential minefields. The use of an autonomous underwater vehicle (AUV) to conduct covert reconnaissance of the

assault lanes fills a current operational deficiency and might significantly increase the probability of success. This paper describes a computer simulation methodology for evaluating tactics that can be used with an AUV in the covert reconnaissance role. Though no AUVs are currently in existence that are capable of this mission, recent technological advances make it clear that such capabilities are possible within the near future.

Our goal in this paper is to develop a number of candidate tactics for a fixed search area and then evaluate them, using the following two questions: what is the best tactic for finding the most mines, and what is the best tactic for searching the most area? To answer these questions we use the mean and standard deviation of our measures of effectiveness (MOEs), i.e. number of mines found and the percentage of area searched, respectively. A time constraint of five hours has been imposed on each mission in order to meaningfully compare tactics in scenarios where complete coverage is not possible. Several types of simulation are used in combination to provide a useful methodology for tactical evaluation in the laboratory.

Historical approaches to computer simulation for mine warfare are mentioned in (Hartmann 91). In this paper, we use statistically based analytic computer simulation together with a physically based virtual world. Our intent is to bridge the gaps between a declared fleet need (a covert search of an amphibious assault lane), a new scientific capability (an oceangoing AUV) and proper employment of new technology (determining effective operational tactics for robots). We evaluate and verify proper operation of each different search technique using actual robot software operating within an underwater virtual world. This end-to-end approach to computer simulation offers a flexible, effective and inexpensive way to develop tactics prior to operational validation.

Computer simulation also allows an extensive series of tests to be rapidly conducted that are not otherwise possible in resource-constrained real environments. Exercises and simulations can be designed and conducted to produce statistically meaningful and validatable results. This approach enables initial evaluation of tactics without the procurement and maintenance costs associated with a complex new system. Certainly the risks associated with putting such new technology into the field warrant that as much preliminary work is accomplished in the lab as possible. The only open question in such an approach is just how accurately the real world can be modeled. Our goal is to properly and exactly model as much of the real world as is necessary in order to ensure meaningful results. Using physics-based sonar and hydrodynamics models provides a realistic and intuitive 3D animation in the virtual world.

**Organization of the paper.** Robot description in Section 2 and problem definition in Section 3 lay out the terms of the AUV minefield search problem. Candidate tactics are described in Section 4, followed by the analytic simulation methodology in Section 5. Detailed evaluation of simulation results appears in Section 6. Example mission generation and virtual world search playback are described Section 7. Conclusions, references and an online software archive complete the paper.

## 2 Robot Description

The NPS *Phoenix* AUV is an existing robot with an operating depth of 5 m, maximum speed of 2 knots and endurance of approximately 2 hours (Figure 3) (Brutzman 96a, 97). *Phoenix* is capable of precise maneuvering in either flight or hover mode. Eight plane surfaces, twin propellers, four cross-body thrusters and a variety of automatic control algorithms make *Phoenix* a highly controllable and hydrodynamically stable vehicle.

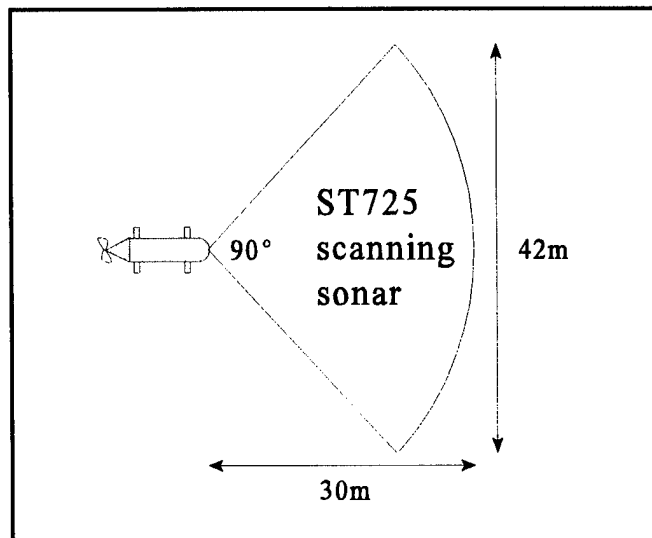
*Phoenix* is capable of detecting and classifying mine-like objects, and can also perform path planning for detected obstacle avoidance (Brutzman 97). Geographic Positioning System (GPS) and Differential GPS (DGPS) position fixes can be obtained in less than a minute per surfacing evolution in support of accurate mapping and navigation. A corresponding underwater virtual world is available for the *Phoenix* AUV that can provide physically accurate sonar and hydrodynamics response in real time in the laboratory (Brutzman 96b, 96c). Robot mission software run in the virtual world can also be run without

modification in the real world. Thus tactics developed for this minefield search project can be directly tested in water.

Active sonars installed on board *Phoenix* include the *Tritech* ST1000 and ST725 which operate at 1000 and 725 KHz respectively, having maximum effective ranges of 30 m and range resolution of approximately 1 cm. Each sonar has a single beam mechanically steerable to any heading in  $0.9^\circ$  increments. The ST1000 is a  $1^\circ$  conical beam typically used for close-aboard obstacle detection or detailed object profiling and classification. The ST725 is a  $1^\circ$  horizontal by  $24^\circ$  vertical cone beam typically used for area search. As shown in Figure 4, each sonar has a swath width coverage of 42 m when scanned through a  $90^\circ$  sector. ST725 vertical coverage at this range is 12m. With 40 seconds required to traverse each 40m box at maximum speed, and a sonar scanning rate of  $(.9^\circ \times 6 \text{ Hz}) = 5.4^\circ/\text{sec}$ , over two complete  $90^\circ$  sonar sweeps are possible in each grid box. Combining this sonar coverage with the maneuverability of the *Phoenix* permits us to plan missions that can completely search each individual grid box, followed by a continuing track to port, to starboard, straight ahead or reversing course.



**Figure 3.** NPS *Phoenix* AUV maneuvering to enter a docking tube (Brutzman 97).



**Figure 4.** A  $90^\circ$  sector scan at a 30 m maximum sonar range setting provides a 42 m wide swath.

### 3 Problem Definition

A total search area of  $1 \text{ Km}^2$  is chosen to approximate the size of the approach and exit lanes needed for landing craft in a contemporary amphibious landing. This tactical challenge is designed to be realistic and easily adaptable to more specific real-world scenarios. Very shallow water search area depth is assumed to range between 5-25 m so that AUV operating depth between 5-20 m can provide 12 m of vertical coverage in a single pass using the *Tritech* sonars. A time period of five hours was chosen based on presumed battery life of the AUV (twice the present capacity of *Phoenix*). This is a likely interval for rapid reconnaissance "in stride" with an amphibious landing. A time limit also avoids the simplicity of performing exhaustive searches (which make choice of tactics moot). These tactical parameters are realistic and representative of real world scenarios.

From the perspective of an underwater robot designer, the most difficult challenges in this scenario include precise navigation, precise vehicle control, and combined detection, classification, localization and avoidance of mine-like objects. *Phoenix* has demonstrated the capability to handle all of these problems. It

must be noted that hull, propulsion and electrical modifications to *Phoenix* would be needed for additional endurance. Nevertheless an AUV solution to this important operational problem appears quite feasible (and affordable) using available technology.

In order to develop intuitive tactics that can be meaningfully compared, we wish to keep the structure of the problem space simple. This tactical problem can be posed as a simple grid search, where grid box size is determined by sonar scan width. The preceding Figure 4 showed the geometry of *Phoenix* sonar scans which leads to a 40 m wide box spacing. Dividing a 1 Km<sup>2</sup> lane into 40 m × 40 m boxes produces a 25 box × 25 box grid of 625 boxes total. We therefore define a grid box numbering convention (with origin defined in the lower left-hand corner) as shown in Figure 5. Following the right-hand rule convention, depth z is positive downward and equals zero at the surface.

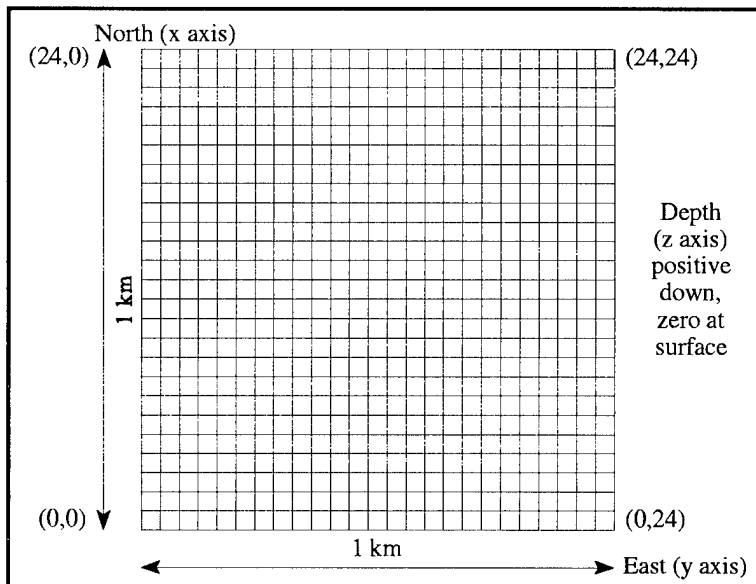


Figure 5. Minefield coordinate system and search box indices.

We are confident that minefield mapping searches can be effectively conducted, since onboard *Phoenix* obstacle avoidance algorithms regain intended track and the robot can navigate in the presence of ocean current (set and drift). Because *Phoenix* control permits effectively maneuvering through such grid boxes in succession, searches of arbitrary complexity can be represented as a simple series of contiguous boxes. Corresponding navigational commands can be produced either by tactical algorithms operating in real time onboard the AUV or by prescribed *mission.script* files. Actual robot missions are therefore specified as a series of track waypoints using the center location of each box in the local real-world coordinate system. Traversal of each grid box enables satisfactory sonar scanning search. Assuming box coordinate pair (0,0) is the local origin, conversion between grid box indices and x-y coordinates is calculated using Equations (1) and (2).

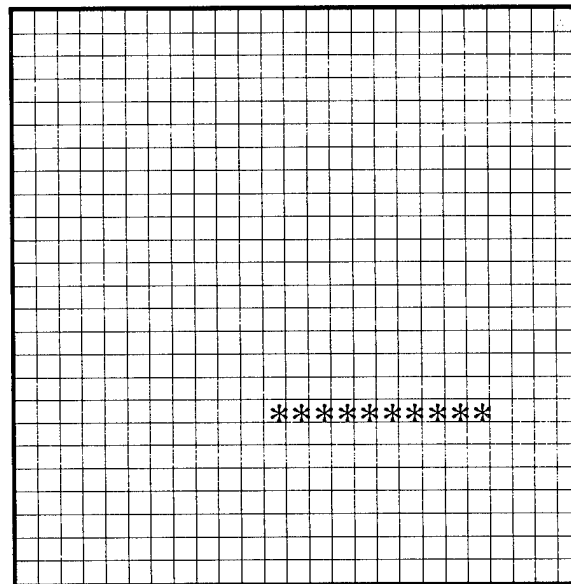
$$box_x (meters) = 40m \cdot box_x (index) + 20m \quad (1)$$

$$box_y (meters) = 40m \cdot box_y (index) + 20m \quad (2)$$

**Minefield Patterns.** Ten mines are randomly distributed to simulate sparsely populated minefields. We consider two types of randomly distributed minefields: uniformly scattered dispersal, and lateral barriers oriented parallel to the landing zone (which might be easily laid by a fishing vessel sailing past the beach). Since search tactics are largely independent of the number of mines present, a total of ten mines per exercise are chosen so that results might be easily interpretable and scalable. All mines are located within the very shallow water depth zone (5-20m), and are assumed moored above the bottom within the 12m vertical coverage of the ST725 where they can be detected and classified by the AUV. No mines are placed outside the search area. The barrier minefield is laid out at 40 m intervals (i.e. one mine per grid box). An example random barrier pattern is shown in Figure 6. More complex minefield patterns

are possible, but these two minefield types require good varieties of coverage suitable for comparing search tactic effectiveness.

It is interesting that an exhaustive search is not possible in this scenario: a nonrepetitive traversal of 625 blocks requires a  $(625 * 40 \text{ m} = 25 \text{ Km})$  track. At maximum speed (2 knots =  $\sim 1 \text{ m/sec} = 3.6 \text{ Km/hour}$ ) *Phoenix* requires 40 seconds to transit each unoccupied box, approximately corresponding to 7 hours for completing the best-case exhaustive search. Thus a 5-hour search limitation (equivalent to at most 450 of 625 boxes searched) allows comparison of search tactics based on relative search effectiveness rather than time to completion. This limitation is intentional. If all searches are permitted to proceed to completion, propulsion endurance constraints may be exceeded. Furthermore, comparison of exhaustive searches only permits using time duration as the MOE. Elapsed time is not an intuitive or accurate metric for comparing relative performance between tactics, since some tactics are optimized for rapid detection of barriers. We believe that number of mines found and percentage of area searched are meaningful MOEs.



**Figure 6.** Example random barrier minefield. Uniformly scattered minefields are also evaluated.

#### 4 Candidate Tactics

Eight different search tactics are considered here. Simplified search pattern diagrams appear in Figure 7. The simplest variations merely run along adjacent rows or columns, and are named **North-South Lawnmower** and **East-West Lawnmower** respectively. These two tactics are basic brute-force searches that take little advantage of minefield knowledge, and as such they are good baseline comparison tests to decide if more complex search patterns improve effectiveness. **Expanding Box** and **Collapsing Box** searches are similar to the lawnmower in that they do not search any box more than once. The **Horseshoe** search incrementally traces three sides of the perimeter from borders toward the center, again only searching each box once. The **Modified Horseshoe** search starts by tracing an initial X between opposing corners (in the hopes of quickly crossing barriers) before resuming a standard horseshoe pattern. The **Horseshoe Detect** search will search inward upon detecting a new mine (in the hope of quickly bracketing barrier boundaries) before resuming the horseshoe pattern. The last pattern evaluated is a **Triangle Detect** search, which spends more time traversing diagonally (again in the hope of quickly intersecting barriers) at the expense of some overlap in grid-box searches.

Many other search patterns are conceivable. These eight patterns were chosen because they provide a good variety between simplicity and sophistication, and also because it is not intuitively clear which search (on average) is most effective. Thus we expect to learn something from the simulation.

#### 5 Analytic Methodology

A precise definition of simulation is the response of a model over time (Fishwick 95). Often the hardest part of any simulation problem is building an adequate model. When modeling a system of interest we primarily wish to capture all relevant detail. Additionally we want the model to retain simplicity and clarity so that results are credible, interpretable and useful. Analysis consists of asking meaningful questions, designing appropriate simulation experiments, conducting simulation experiments until a predetermined level of accuracy is achieved, and finally evaluating simulation results to answer the original

questions of interest. Often simulation results and real-world testing leads to improved understanding of the system and corresponding model improvements. The analytic methodology is summarized in Figure 8.

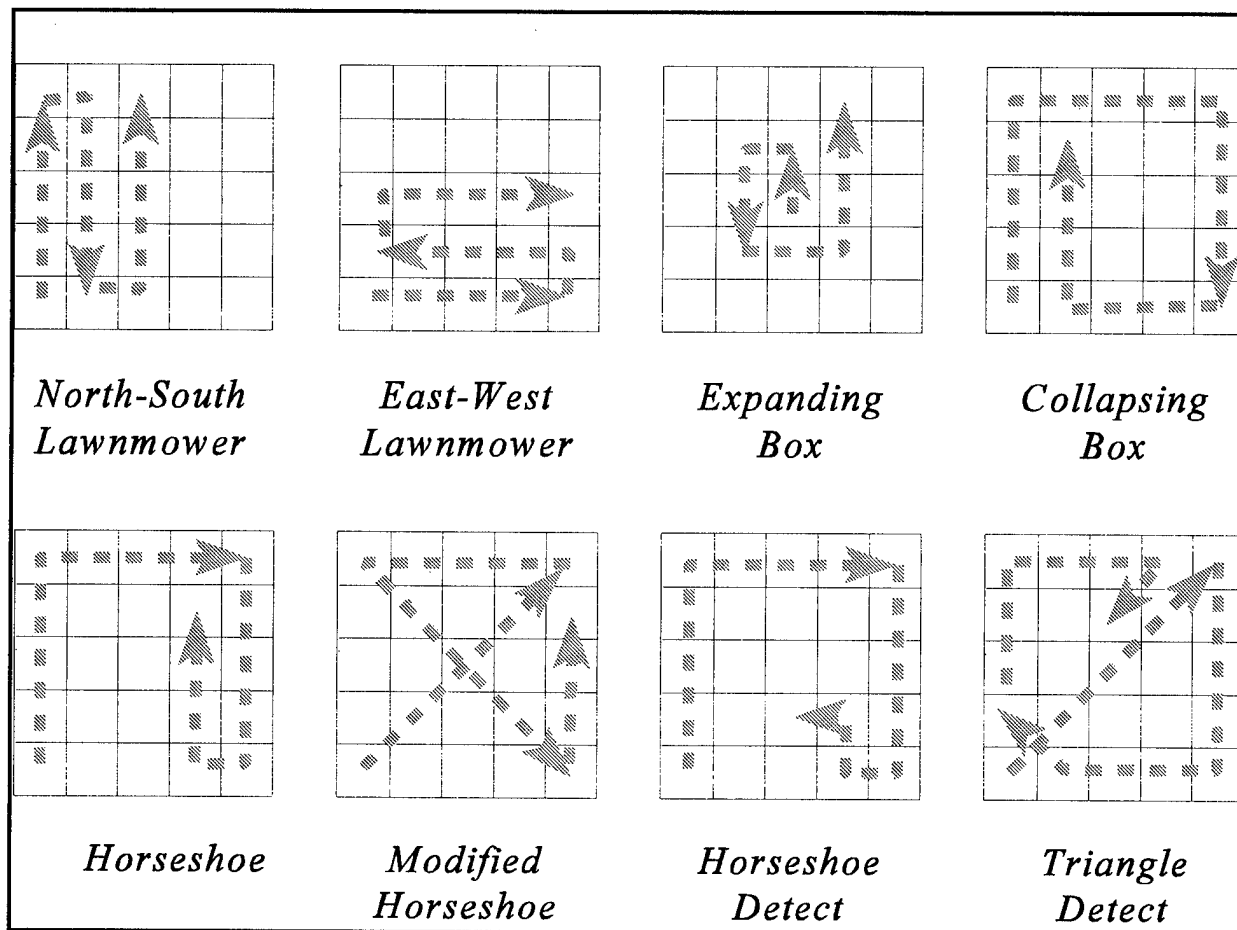


Figure 7. Eight search tactics are evaluated and compared.

- I. Define problem and determine questions of interest, in order to define required level of detail for the system model
- II. Build system model by defining appropriate state variables and corresponding state-transition events
- III. Design simulation experiment and specify measures of effectiveness (MOEs) that can likely provide answers to questions of interest
- IV. Perform simulation experiments (i.e. record the model behavior over time) until predetermined degrees of accuracy in MOEs are reached
- V. Analyze and interpret aggregate simulation MOE results, answering original questions of interest
- VI. Perform validation experiments in real world (if possible), then adjust model and repeat entire process as necessary

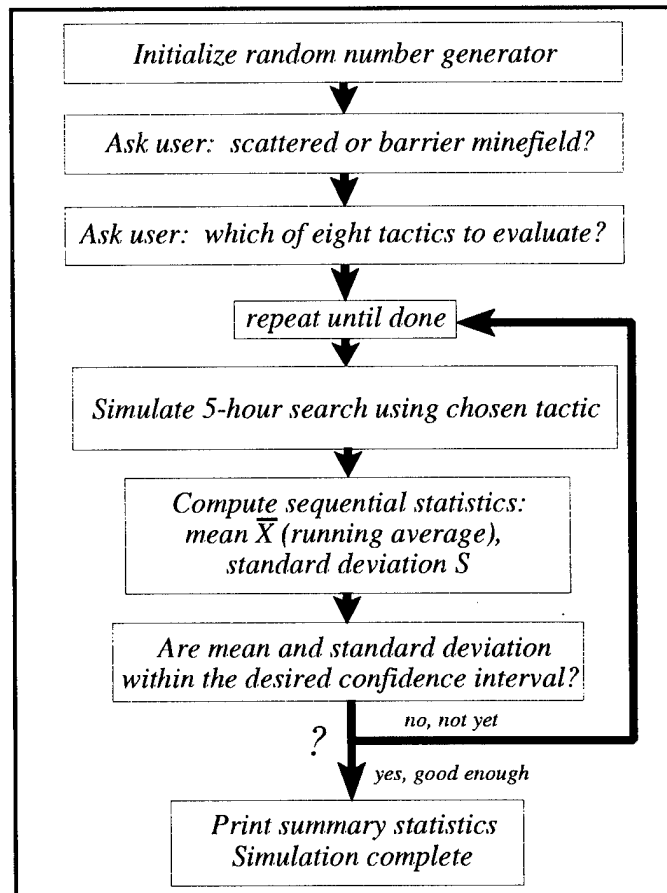
Figure 8. Analytic simulation methodology.

We have developed a simple program written in the C language that simulates a minefield search by stepping from grid box to grid box according to the tactic of interest (Brutzman 96d). By repeating this program multiple times for randomized minefield distributions, we can average search performance results until the standard deviation of the mean converges within a predetermined confidence interval. In this manner we can exhaustively test each tactic against each minefield until adequate data is obtained to meaningfully answer our MOEs (Bailey 95).

Pseudocode for simulated conduct of a single minefield search appears in Figure 9. Each minefield search is called a *replication*. For this problem, 5-hour search replications are repeatedly performed to completion. Counts of mines found in each search are statistically evaluated until results have stabilized and converged within a predetermined range. A flowchart for the overall simulation program (of repeated replications) appears in Figure 10.

- Initialize all variables
  - Position AUV in starting box and face starting direction
  - Search first box and initialize statistics
- Repeat until 5-hour deadline or full 1 Km<sup>2</sup> grid searched
  - Perform scanning sonar search while transiting
  - Is a mine found in the next box?
    - No: mark box searched/empty
    - Yes: mark box searched/mine, increment mines-detected count
  - Determine next box according to tactic
  - Transit to next box (AUV performs obstacle avoidance if needed)
- Output MOE results from a single search of the minefield (e.g. number of mines found and % area searched)

**Figure 10.** Pseudocode for simulating conduct of a single minefield search using a given tactic. Each minefield search produces results for a single simulation replication.



**Figure 9.** Determining tactic performance through multiple replication experiments: analytic simulation flowchart.

As specified previously, the primary question of interest in this problem is how to determine relative effectiveness of search tactics in plausibly defined very shallow-water minefields, given a time constraint of only five hours for the search. MOEs for each simulation experiment include number of mines detected (out of 10 total) and percentage of area searched.



When running simulations with large numbers of replications, calculation of mean and standard deviation can become computationally prohibitive. We use formulae for mean and standard deviation called *sequential statistics* that incrementally modify the preceding value of the statistic with the weighted increment corresponding to the current sample (Bailey 95) (Law 91). This approach lets us efficiently repeat simulated minefield searches for thousands of replications, without computational slowdown, until the MOE statistics stabilize inside a desired confidence interval.

When collecting statistics on each tactic, randomly distributed minefields are repeatedly created and searched one after another for five-hour simulation-time intervals. MOEs for each replication are statistically averaged until the standard deviation of the replications has converged to a stable value, as determined by a 95% confidence interval (CI). Repeated summations of long series of values are avoided by using sequential statistics for mean and standard deviation. For example, the aggregate mean after each replication (i.e. iteration  $n+1$ ) is calculated using a weighted average of previous and latest results (Equation 3). Variance and standard deviation sequential statistics appear in Equations 4 and 5.

$$\text{Sample mean: } \bar{X}_{n+1} = \frac{(n \cdot X_n + X_{n+1})}{n + 1} \quad (3)$$

$$\text{Sample variance: } S^2_{n+1} = \frac{1}{n} \sum_{i=1}^{n+1} (X_i - \bar{X}_{n+1})^2 = \frac{1}{n} \sum_{i=1}^{n+1} X_i^2 - \frac{n+1}{n} \bar{X}_{n+1}^2 \quad (4)$$

$$\text{Sample standard deviation: } S_{n+1} = \sqrt{S^2_{n+1}} \quad (5)$$

Rather than simulate replications for an arbitrarily large number of runs, we wish to terminate when results are stable. Regarding the MOE for the number of mines found, a large-sample  $100(1 - \alpha)\%$  confidence interval (CI) (Mendenhall 91) is applied for the mines-found mean to decide when simulation results have converged satisfactorily. Variance of the mines-found sample mean is presented in Equation 6 and the large-sample CI formula for sample mean convergence is presented in Equation 7.

$$\text{Variance of mines-found mean: } S^2_{\bar{X}_{n+1}} = \frac{1}{n} \sum_{i=1}^{n+1} \bar{X}_i^2 - \frac{n+1}{n} (\text{mean of all } \bar{X})_{n+1}^2 \quad (6)$$

$$\text{Convergence confidence interval for mines-found mean } CI_{\text{mean}}: \bar{X}_{n+1} \pm z_{\alpha/2} \left( \frac{S_{\bar{X}_{n+1}}}{\sqrt{n+1}} \right) \quad (7)$$

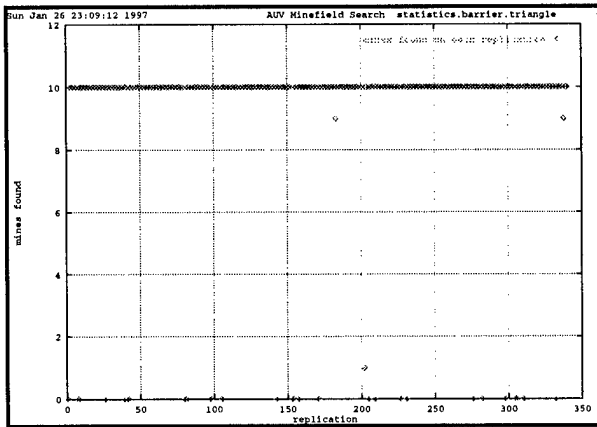
Typical termination of replications is based on confidence that the mines-found mean has converged within some user-defined accuracy, where a 95% CI ( $\alpha = 0.05$ ) corresponds to standard normal probability distribution value of  $z_{\alpha/2} = z_{0.025} = 1.96$ . We continue replications until the difference between upper and lower confidence interval values is less than the user-defined accuracy (typically 0.1 mines). The termination conditional relation is found by rearranging Equation 7 into Equations 8 and 9.

$$2 \cdot z_{\alpha/2} \left( \frac{S_{\bar{X}_{n+1}}}{\sqrt{n+1}} \right) \leq (\text{user-defined accuracy}) \quad (8)$$

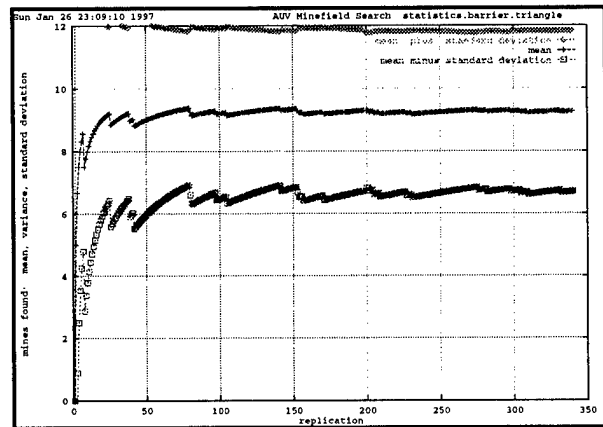
$$S_{\bar{X}_{n+1}} \leq \frac{(\text{user-defined accuracy}) \sqrt{n+1}}{2 \cdot z_{\alpha/2}} \quad (9)$$

### 6 Analysis and Evaluation of Simulation Experiments

Extended sets of simulations were run for each of the eight tactics, in both types of minefields (uniformly scattered and random barrier). Figure 11 shows individual replication search results for an expanding box search, confirming that [0..10] mines were found per search. Figure 12 provides a representative plot of replication MOE results for an expanding box search, plotting average mines detected and standard deviation of mines detected, all versus number of replications. As expected, the sample mean and sample standard deviation converge to stable values as the number of replications increases. Stability can be determined visually (1000-5000 replications are typically sufficient), or automatically by continuing replications until the CI for the mean is within predetermined statistical bounds (as specified in Equation 9).

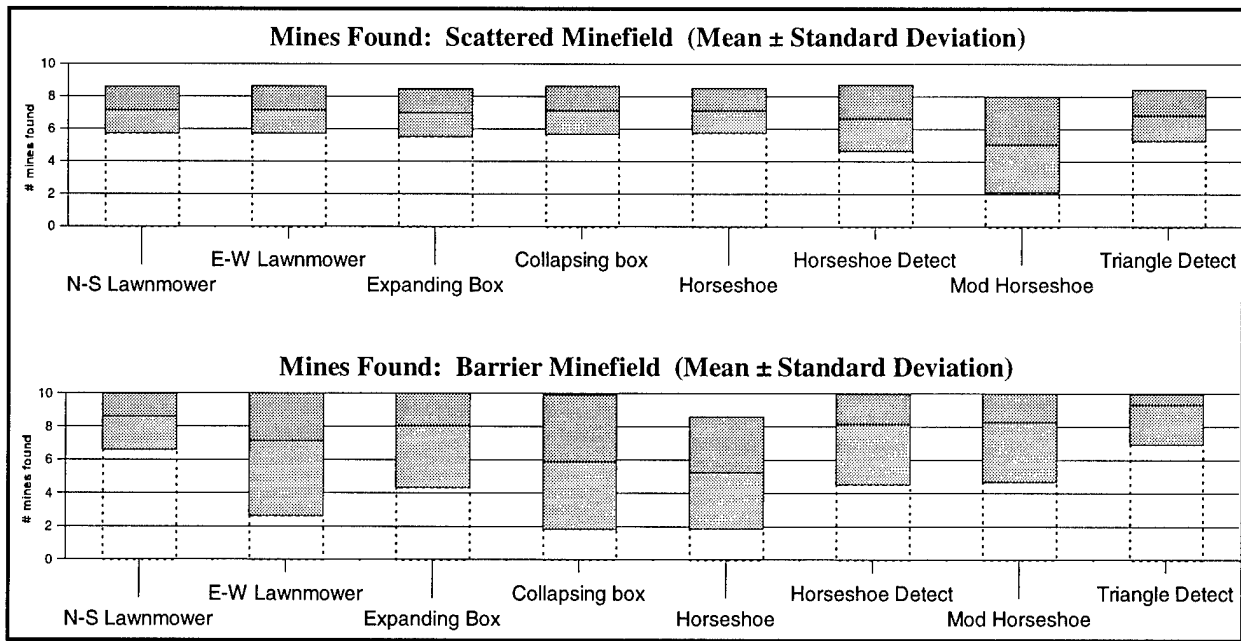


**Figure 11.** Mines found by Triangle Detect tactic versus barrier minefields, all within legal range [0..10], shown as replication count increases. The distribution of these sample values appears in Figure 13 (lower).

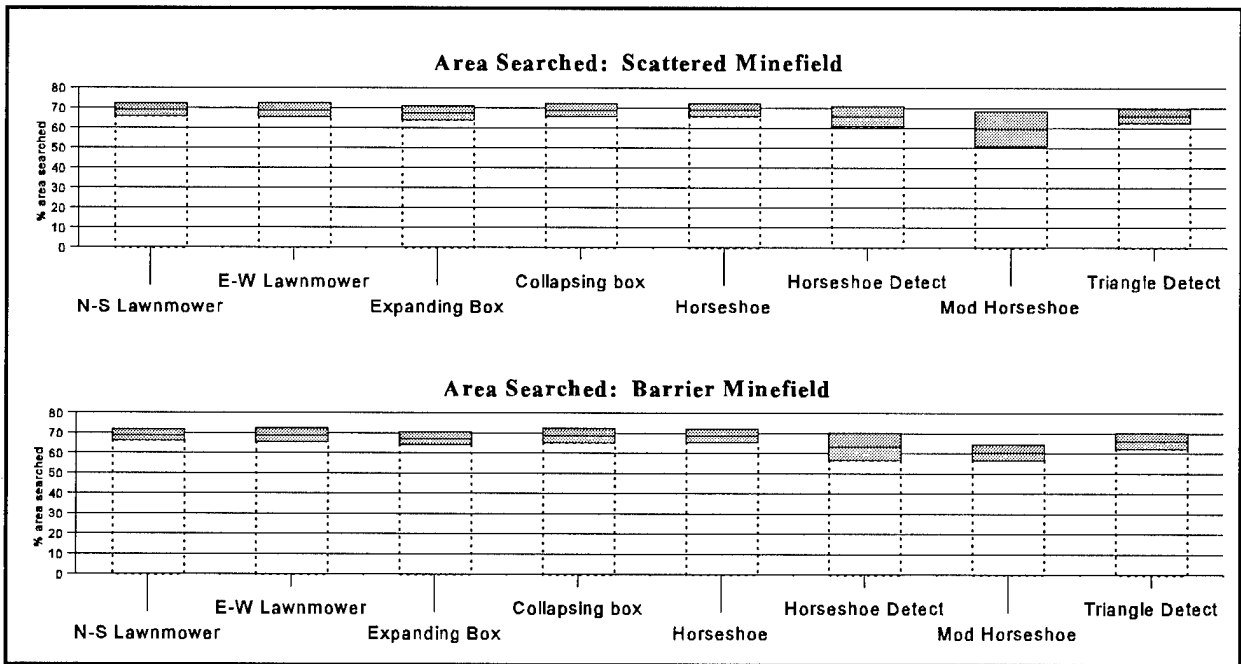


**Figure 12.** Aggregate mean and aggregate standard deviation of total-mines-found MOE for Triangle Detect tactic versus barrier minefields, shown as replication count increases.

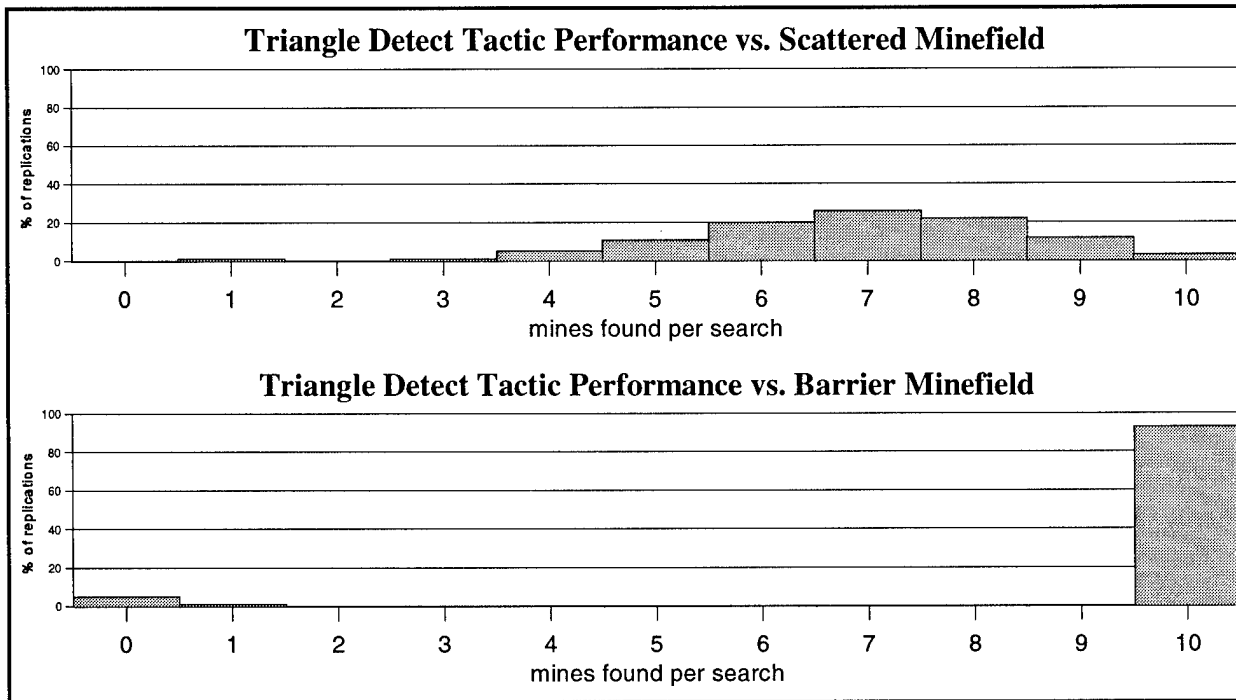
Figures 13 and 14 plot the relative effectiveness of all eight tactics against both minefield types for each of the two MOEs (number of mines detected and area searched). Figure 15 shows a histogram of Triangle Detect tactic performance, i.e. the distribution of replication results (raw data shown in Figure 11) which contributed to MOE CI values. Many interesting conclusions can be determined from these simulation results.



**Figure 13.** Measure of effectiveness (MOE): **number of mines found**. Bars indicated mean ± standard deviation of aggregate simulation experiments for eight tactics versus two types of minefield.



**Figure 14.** Measure of effectiveness (MOE): **percentage area searched**. Very little variation in performance is evident, even for tactics which include some repeated traversal across boxes already searched. A single exception is the Modified Horseshoe tactic which performs poorly against scattered minefields.



**Figure 15.** Examination of Triangle Detect performance over all search replications showing results distribution..

Our first analytic conclusions are that seven of the eight tactics appear roughly equivalent in terms of area searched (Figure 14). This is not surprising since the tactics produce little or no overlap of previously searched boxes. Close inspection prompted by low performance of the Modified Horseshoe tactic revealed a sporadic flaw in the mission logic, causing it to stop after attempting to search for the end of a potential minefield barrier. These results are useful in that they confirm expectations about area search and also reveal a previously unsuspected fault in one of the tactics.

Our second set of conclusions is that all working tactics detect a roughly equivalent number of mines when working against a uniformly scattered minefield (Figure 13, upper). This is also reasonable since an AUV can do little in such a scenario but search as much as possible. Furthermore no evidence leads us to expect that a new tactic might do better than these in such a minefield. So far there is no compelling reason to prefer any one of the seven working tactics over another.

Our third set of conclusions is surprising and useful. Based on the mines-found MOE, using the mean plus standard deviation capped at a maximum of 10 (Figure 13, lower), it appears possible for any of the eight tactics to find most mines in a random barrier minefield. However, some tactics often do poorly as evidenced by wide standard deviations. Close examination of MOE variation reveals that the Triangle Detect tactic has consistently higher performance in barrier minefield searches. This is reasonable since the “detect” tactics exploit the possibility that mines are laid in a line. Perhaps surprisingly, Triangle Detect is consistently superior to the others. We therefore conclude that **Triangle Detect** is the best tactic for these search scenarios.

Our final conclusion is that this simulation methodology first confirmed our expectations, and then provided additional information on relative tactic superiority that is unavailable by other means. This approach appears useful for analyzing many types of real-world problems.

## 7 Example Mission Generation and Virtual World Playback

*Phoenix* has a simple mission script language for AUV control that is similar to shipboard watchstander orders (Brutzman 96b, 97). Analytic simulation runs can produce mission scripts to fully record the robot orders needed to replicate an example search. For a simple search, these orders can be played back meaningfully for any minefield. More complex searches that successfully adapt and change strategy based on detected mine location (such as Triangle Detect) can be directly converted into robot tactical code for in-water use. Figure 16 shows an excerpt from the simulated expanding box search mission script, generated by a single search replication. This script can be used verbatim to rehearse analytic simulation results, driving the AUV in the real world or in the virtual world.

Once simulated search mission scripts have been generated, they can be played back in the virtual world to verify correctness of individual tactics.

Figure 17 shows an example view from behind the AUV as it starts an expanding box search. AUV and mines are drawn to scale, large cylinders are drawn around each mine to suggest standoff range and to permit users to locate mines visually from a distance.

Completion of a mission produces a summary geographic plot (Figure 18) as well as numerous other time-series plots of AUV physical parameters. Aside from present physical restrictions on vehicle depth and endurance, missions run in the virtual world are ready to be run in real world. Detailed results of all eight tactic simulations are available in an online archive (Brutzman 96d).

```

time      0
position  65 65 20
orientation 0 0 0
course    0
rpm       700 /* 2 knots */
depth     20
thrusters-on
standoff-distance 10

# waypoint  X    Y    Z # grid indices

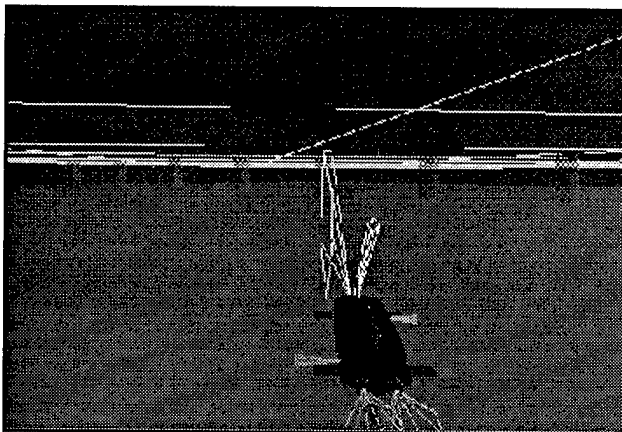
waypoint  65.6  65.6 20 # box 0 0
waypoint  196.9 196.9 20 # box 1 1

.. 4.9 hours of additional waypoints omitted ..

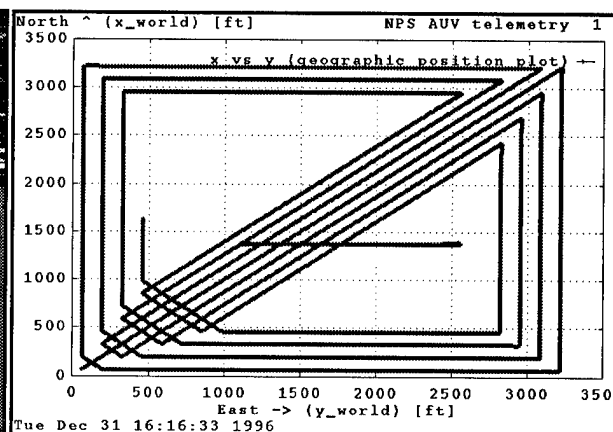
waypoint  459.3 1640.4 20 # box 3 12
# simulated search mission.script complete

```

**Figure 16.** *mission.script.barrier.triangle* excerpt. (Brutzman 96d)



**Figure 17.** AUV over-the-shoulder view of barrier minefield.



**Figure 18.** Geographic plot of 5-hour Triangle Detect search. Note detection of lateral barrier minefield.

## 8 Conclusions

Analytic simulation in combination with virtual world rehearsal is a valuable new methodology for prototyping underwater robots and evaluating search tactics. This approach appears applicable to a wide range of problems. Technology is available today to build an oceangoing AUV that can effectively conduct rapid minefield search in support of fleet requirements. The NPS Center for AUV Research continues developmental work on computer software and hardware requirements for constructing low-cost, stable, mission-capable AUVs.

## 9 References

- Bottoms, Al, chair and editor, *Symposium on Autonomous Vehicles for Mine Countermeasures*, Mine Warfare Association, Naval Postgraduate School, Monterey California, April 4-6 1995.
- Bottoms, Al, chair and editor, *Symposium on Technology and the Mine Problem*, Mine Warfare Association, Naval Postgraduate School, Monterey California, November 18-21 1996.
- Bailey, Michael P. and Brutzman, Donald P., "The NPS Platform Foundation," Proceedings of the Ninth European Simulation Multiconference, Prague, Czech Republic, June 5-7 1995. Available at <http://www.stl.nps.navy.mil/~brutzman/eurofnd.ps>
- Brutzman, Don, "Virtual World Visualization for an Autonomous Underwater Vehicle," *Proceedings of the IEEE Oceanic Engineering Society Conference OCEANS 95*, San Diego California, October 12-15 1995, pp. 1592-1600. Available at <ftp://taurus.cs.nps.navy.mil/pub/auv/oceans95.ps.Z>
- Brutzman, Don, "Tutorial: Virtual World for an Autonomous Underwater Vehicle (AUV)," *IEEE Oceanic Engineering Society Conference OCEANS 96*, Fort Lauderdale Florida, September 23-26 1996. Available at [http://www.stl.nps.navy.mil/~auv/uwv\\_tutorial.html](http://www.stl.nps.navy.mil/~auv/uwv_tutorial.html)
- Brutzman, Don, Burns, Mike, Campbell, Mike, Davis, Duane, Healey, Tony, Holden, Mike, Leonhardt, Brad, Marco, Dave, McClarin, Dave, McGhee, Bob and Whalen, Russ, "NPS Phoenix AUV Software Integration and In-Water Testing," *Proceedings of the IEEE Oceanic Engineering Society Conference AUV 96*, Monterey California, June 3-6 1996, pp. 99-108. Available at <ftp://taurus.cs.nps.navy.mil/pub/auv/auv96.ps>
- Brutzman, Don, *NPS Phoenix AUV Software Reference*, November 1996. Available at [http://www.stl.nps.navy.mil/~auv/software\\_reference.html](http://www.stl.nps.navy.mil/~auv/software_reference.html)
- Brutzman, Don, "Simulation Evaluation of AUV Search Tactics," UW3303 class home page, December 1996. Available at <http://www.stl.nps.navy.mil/~auv/simulation>
- Brutzman, Don, Healey, Tony, Marco, Dave and McGhee, Bob, *The Phoenix Autonomous Underwater Vehicle*, chapter, *AI-Based Mobile Robots*, Kortenkamp, David, Bonasso, Pete and Murphy, Robin, editors, to appear 1997. Available at <http://www.stl.nps.navy.mil/~brutzman/aimr.ps>
- Fishwick, Paul, *Simulation Model Design and Execution: Building Digital Worlds*, Prentice-Hall, Englewood Cliffs New Jersey, 1995. Information and software available via <http://www.cis.ufl.edu/~fishwick>
- Hartmann, Gregory K. with Truver, Scott C., *Weapons that Wait: Mine Warfare in the U.S. Navy*, second edition, Naval Institute Press, Annapolis Maryland, 1991.
- Law, Averill M. and Kelton, David W., *Simulation Modeling and Analysis*, second edition, McGraw-Hill, New York, 1991.
- Mendenhall, William, Wackerly, Dennis D. and Scheaffer, Richard L., *Mathematical Statistics with Applications*, fourth edition, PWS-Kent Publishing Company, Boston, 1990.

### **Acknowledgements**

We thank many people who helped make this work possible. Mike Bailey defined the analytic simulation methodology. NPS Center for AUV Research Director Tony Healey, faculty and students built and implemented the *Phoenix* AUV. Mike Zyda advised the construction of the virtual world. Jim Eagle and Al Bottoms provided helpful review comments. Simulation program improvements were provided by Undersea Warfare students LT Orin Collier USN, LCDR Frederic Forney USN, LCDR Frederick Gaghan USN, LT Eric Horning USN, LT Kevin Melody USN, and LT Peter Smith USN. Support for this work was provided by the NPS Research Initiation Program (RIP).

### **Author Information**

Don Brutzman is a computer scientist working in the Undersea Warfare Academic Group at the Naval Postgraduate School. A retired nuclear submarine officer, his research interests include underwater robotics, real-time 3D computer graphics, artificial intelligence and high-performance networking. He is a member of the Institute of Electrical and Electronic Engineers (IEEE), the Association for Computing Machinery (ACM) Special Interest Group on Graphics (SIGGRAPH), the Virtual Reality Modeling Language (VRML) Consortium and the American Association for Artificial Intelligence (AAAI).

LT Bryan Brauns graduated from the United States Naval Academy in 1989 with a Bachelor of Science degree in Oceanography. He served onboard the USS CARON (DD-970) as the Auxiliaries Officer and Combat Information Center Officer from 1990-1993. He then served a sea tour onboard the USS SAN JACINTO (CG-56) as Combat Information Center Officer and Navigator from 1993-1995. He has been awarded the Navy Achievement Medal with a gold star in lieu of a second award and the Combat Action Ribbon for service in the Gulf War. He is presently earning a Master's degree in Physical Oceanography and a primary code in Undersea Warfare.

LCDR Paul A. Fleischman graduated from the University of New Mexico in 1986 with a B.A. in Economics. His first assignment was as Weapons Officer onboard the USS ROANOKE (AOR 7). After completion of Explosive Ordnance Disposal School in December 1989, he reported to EODMU FIVE in Subic Bay, RP. He served as Officer in Charge of two mobile EOD detachments before assuming duties as Assistant Operations Officer. In November 1993 he reported as Officer in Charge of EODMU FIVE Detachment GUAM. He transferred to the Undersea Warfare curriculum at the Naval Postgraduate School in September 1995 and is working toward a Master's Degree in Physics.

LT Anthony J. Lesperance graduated from the U.S. Naval Academy in 1991 with a B.S. in Chemistry. His first assignment was onboard the USS RICHMOND K. TURNER (CG 20) as Electrical/Auxiliaries Officer and Communications Officer. He transferred to the Undersea Warfare curriculum at the Naval Postgraduate School in July 1995 and is working toward a Master's Degree in Engineering Acoustics.

LT Brian Roth earned his commission through OCS after receiving a Bachelor of Science Degree in Physics from Taylor University. After commissioning on 02 June 1989, he completed nuclear power training before reporting to the USS OHIO (SSBN 726 Gold) in December of 1990. After serving two and a half years and four ballistic missile submarine patrols, he transferred to PCU TUCSON (SSN 770). LT Roth served as the Damage Control Assistant and Assistant Engineer where he received invaluable experience building one of the Navy's newest and most capable fast attack submarines. LT Roth's awards include the Navy Achievement Medal with three gold stars and the National Defense Service Medal. LT Roth is married to the former Sharice Pratt of Marion, Indiana. They have three children, Tyler, Tanyale, and T.J. Their next assignment is to the USS OKLAHOMA CITY (SSN 723) in Norfolk, Virginia where he will serve as the Engineer Officer.

LT Forrest Young graduated from the NROTC program at the University of California, Berkeley in 1990. He is a nuclear-trained surface warfare officer. He served on board USS ARKANSAS 1992-1995.

# TRANSITION AND R&D RECOMMENDATIONS RESULTING FROM THE MCM TACTICAL ENVIRONMENTAL DATA SYSTEM (MTEDS) PROGRAM

Samuel G. Tooma  
Daniel F. Lott

Seafloor Sciences Branch  
Marine Geosciences Division  
Naval Research Laboratory  
Stennis Space Center, MS 39529

**Abstract --** During the period August 1992 through September 1995, the Naval Research Laboratory (NRL) conducted a program entitled "MCM Tactical Environmental Data System" (MTEDS). The objective of this program was to demonstrate at sea a capability to make in situ measurements of environmental parameters needed for real time use by the MCM tactical action officer for optimum utilization of available MCM assets. This program addresses the deficiency that the MCM fleet does not have an on-board capability to make these measurements and, therefore, must rely on climatological/historical data bases. Although historical information is adequate for MCM planning, it clearly is not acceptable for determining tactical mode settings in the highly dynamic littoral regions where MCM operations will be conducted. The major milestone of the MTEDS program was an at-sea demonstration of the desired capability. The objectives of this sea test were to demonstrate that selected environmental data critical to MCM tactical decision-making can be: (1) measured in situ; (2) collected while underway at 4-5 kn; (3) stored in an off-the-shelf data base management system residing within a Navy-standard desktop workstation; (4) displayed on the workstation screen in real time; and (5) used by resident algorithms to predict information of tactical importance to MCM (e.g., mine burial probability). These objectives were all met during this sea trial, and the following environmental data were collected: (1) survey quality bathymetry using the ship's echo sounder and the Applied Research Laboratory:University of Texas (ARL:UT) collection and processing hardware; (2) water current velocity profiles via a hull-mounted, off-the-shelf acoustic Doppler current profiler; (3) seafloor sediment classification using the ship's echo sounder transducer and NRL's acoustic seafloor classification system processor; (4) sound speed profiles using an off-the-shelf depth excursion tow-fish and an off-the-shelf conductivity, temperature, and depth profiling system; (5) AN/SQQ-32 sonar reverberation data via recorded SQQ-32 sonar data provided by ARL:UT; and (6) differential GPS using the ship's navigation system.

A follow-on major milestone was an at-sea demonstration of selected MTEDS environmental measurement capabilities from an MCM ship. This was achieved during the PURPLE STAR MCM exercise from USS WARRIOR (MCM-10).

From the MTEDS program, a list of recommended sensors, combined with existing ship combat systems such as the SQQ-32 sonar, has been developed and which outlines specific transition recommendations for providing a real time environmental monitoring capability for all MCM ships.

## I. INTRODUCTION

Mine countermeasures (MCM) operations are significantly affected by the natural environment [1]. Tactical considerations such as system mode settings, ship and helicopter track spacing, and optimum utilization of assets are all driven by the existing environmental conditions in the operation area. The environmental impact can be so great that the most basic of MCM tactical decisions, sweep or hunt, is often driven by the environment. Relative to individual MCM systems, such as the mine hunting sonar, knowledge of the environment can produce "go/no go" decisions. For example, poor acoustic conditions or high likelihood of mine burial can severely reduce the effectiveness of acoustic minehunting and force the need to rely on influence sweeping. Significantly complicating this situation is that the environmental conditions which exist in almost all littoral regions of the world where MCM operations are likely to be conducted are extremely variable in both space and time. Oceanographic, bottom, acoustic, and meteorological conditions which exist at a location at one point in time can be significantly different just a few hundred meters away or within a few hours (e.g., after a squall passes or the tide changes). Because of this temporal and spatial variability, climatological data bases of an area, if they exist at all, are not adequate for supporting MCM on-scene tactical decision making. To address this problem, a capability is required to monitor the environmental conditions during an MCM operation and, based on changing environmental conditions, to continually adjust mode settings and tactical utilization of assets as the operation proceeds. Presently, the US Navy does not have this capability.



In July 1991, following the Persian Gulf War, the Office of Naval Technology of the Office of Naval Research issued guidance for developing a technical program designed to address the environmental deficiency described above. This guidance had the following requirements. The program must:

- Support MCM Tactical Decision-Making Using In Situ Environmental Information
- Use Off-The-Shelf Sensor Technology Whenever Possible
- Use Combat Systems Organic to MCM Ships for Environmental Data Collection Whenever Feasible
- Provide Benefits to the Fleet in the Near Term (5 to 7 years)
- Integrate Capabilities Into Existing or Planned MCM Combat Systems, Whenever Feasible
- Demonstrate Capability Via an At-Sea Test in FY95
- Begin Transition to 6.3/6.4 in FY96

The Naval Research Laboratory (NRL), Stennis Space Center, MS convened a 2-day workshop at Diamondhead, MS in January 1992 to define the focus of a program proposal that addressed the above criteria. The resultant proposal, entitled "MCM Tactical Environmental Data System (MTEDS)" was formulated and submitted to ONT for review in April 1992. The proposal was reviewed by the ONT review panel and accepted in June 1992. Initial funding was received by NRL in August 1992. Upon receipt, funds were immediately forwarded by NRL to the other two major participants of the MTEDS program, the Naval Surface Warfare Center, Coastal Systems Station (CSS) in Panama City, FL and the Applied Research Laboratory at the University of Texas (ARL:UT) in Austin, TX.

The basic objective of the MTEDS program was to demonstrate an in situ capability for making critical environmental measurements. These measurements would be used, in turn, for real time use by the MCM tactical action officer to optimize utilization of available MCM assets. The focus of this effort was to address issues associated with performance prediction of the AN/SQQ-32 mine hunting sonar, tactics and handling of the MCM ship and mine neutralization vehicle, prediction of mine burial upon impact with the bottom, prediction of magnetic swept path, and performance prediction of optical minefield reconnaissance sensors.

The MTEDS program has been successfully carried out. Two at-sea demonstrations were conducted. The first was performed from the R/V SEWARD JOHNSON during 7-14

February 1995 in a test area 60 nmi west of Key West, FL, and the second was performed from the USS WARRIOR (MCM-10) as part of the MCM exercise PURPLE STAR within Onslow Bay off North Carolina. The first test was more science oriented and was designed to verify performance of the full-up suite of on-board sensors. The second test was more operationally oriented and focused on the use of sensors normally installed on MCM ships (AN/SQQ-32 minehunting sonar, AN/UQN-4 fathometer, TR-192B transducer, and differential GPS navigation system). Based on the results of these demonstrations, techniques and methodologies for providing a real time environmental measurement capability for MCM ships have been defined. The purpose of this report is to concisely document the recommendations derived from the MTEDS program so that transition sponsors will have a recommended definition of the way ahead for providing this capability on-board US Navy MCM ships.

## II. DISCUSSION

### A. General

The detailed approach used to meet the MTEDS objective given above is provided in the MTEDS Master Plan [2]. Basically, this approach involved: (1) conducting several separate but interrelated technical tasks; (2) using several sea tests designed to test the various environmental sensors selected for the program; (3) developing interfaces for formatting and "conditioning" the resultant environmental data for inclusion into an off-the-shelf data base management system; (4) developing simple graphical user interfaces to display the data; and (5) making the data available for algorithms designed to predict environmental/acoustic conditions, to predict MCM system performance, and to make tactically useful predictions such as mine burial probability. The culmination of this effort was the at-sea demonstrations where all these capabilities were functioning at the same time.

### B. Technical Tasks

The MTEDS program consisted of eight technical tasks.

1) Ground Truth Area Selection and Characterization: The objectives of this task were to: (a) select three sea test areas which would provide a range of typical MCM operational environments for testing the various MTEDS sensors and systems; and (b) characterize these areas by building as complete an environmental data base as possible using available historical data [3].

2) **Sediment Classification and Airborne Electromagnetic System Development:** The objectives of this task were to: (a) develop and demonstrate a remote sensing technique which would provide environmental parameters required for computing the magnetic swept path generated by MCM magnetic sweeping gear [4]; and (b) develop and demonstrate a near real time, remote sediment classification capability that would provide sediment geotechnical properties required by mine burial and sonar performance prediction models [5], [6].

3) **Sensor Integration and Interfacing with Prototype Software and Computers:** The objectives of this task were to: (1) demonstrate the feasibility of integrating environmental sensor and navigation system outputs via a common interface for input into a geographic information system (GIS) data base residing within a Navy standard desktop workstation [7]; (2) conduct at-sea testing of selected off-the-shelf environmental sensors for their ability to provide data at the resolutions required by the environmental and MCM algorithms [8], [9]; and (3) demonstrate the potential of shipboard combat systems (e.g., the AN/SQQ-32 mine hunting sonar and AN/UQN-4 fathometer) to provide needed environmental information [10], [11].

4) **Data Base Architecture Construction:** In order to demonstrate that collected environmental data could be used in real time for support of MCM tactical decision making, it was necessary to have the capability to store the measured data in a GIS, display the data, and have the data accessible to algorithms needing them to make their predictions. Therefore, the objective of this task was to provide an optimum architecture which would allow for maximum interaction capability between in situ-collected environmental data, historical data bases, environmental and system performance prediction algorithms, and tactical system operators aboard the MCM ship. This task also included the design of a graphical user interface and a data visualization scheme to enhance user interaction with the MTEDS capability and assure data quality during acquisition [7].

5) **Environmental Algorithm Selection, Modification, and Development:** The objective of this task was to identify, modify, and develop, if necessary, environmental, acoustic, and tactical environmental models to include recent improvements in shallow water environmental modeling. Because of funding and time constraints of the MTEDS program, the focus of this task was to identify the "best" existing shallow water models rather than develop new models [12], [13].

6) **Combat System Definition and Prototype Tactical Algorithm Selection, Modification, and Development:** The objectives of this task were to: (a) define and prototype a tactical decision aid system which links environmental measurement technology with existing combat systems within the MCM ship; and (b) prototype automated tactical decision aid software to use measured environmental data. With respect to the latter, MCM tactical decision aids are mostly in the form of look-up tables and nomograms within the NWP-27 series publications (the standard operating procedure (SOP) manuals for MCM) and use environmental data provided in the Mine Warfare Pilots (historical environmental data compiled by the Naval Oceanographic Office for selected areas). This task involved, whenever possible, the coding of these SOPs to run on the Navy standard desktop workstation and to use environmental data measured in situ.

7) **MTEDS Documentation Preparation and Demonstration:** The objectives of this task were to: (a) conduct a full-up demonstration of the MTEDS capabilities at sea; and (2) prepare final reports which fully document all technical aspects of the MTEDS capability.

8) **Environmental Tactical Decision Aid Development for the MH-53 Helicopter:** This task was included in the MTEDS program in order to provide some environmental support for the MH-53 helicopter, the airborne MCM component. The objective of this task was to develop a Compressed Nautical Chart (CNC) of the demonstration test area that was compatible with the Navy standard Compressed Aeronautical Chart (CAC) data base. Both the MH-53 and the Navy Tactical Command System-Afloat have validated requirements for CNCs. Therefore, in direct support of the MH-53 mission planners, this task would incorporate the CNC into a GIS in which multiple data bases (e.g., side scan sonar acoustic imagery, bathymetry, mine-like contacts, shorelines, and environmental update information) could be overlaid onto the CNC base map already available to the MH-53. This capability would significantly improve tactical decision support to this platform [12].

### *C. At-Sea Demonstrations*

The major milestone of the MTEDS program was the at-sea demonstration conducted during 7-14 February 1995 approximately 60 nmi west of Key West, FL. The demonstration was part of the month-long (1-28 February) Key West Campaign, a major multi-national, multi-discipline field effort centered around the Coastal Benthic Boundary Layer research program funded by the Office of Naval Research and led by the Naval Research Laboratory. The Key West Campaign was supported by four

oceanographic research vessels and by more than 100 scientists and technicians representing five countries [15]. The R/V SEWARD JOHNSON, operated by the Harbor Branch Oceanographic Institution in Ft. Pierce, FL was used for the MTEDS demonstration. Fig. 1 provides a Key

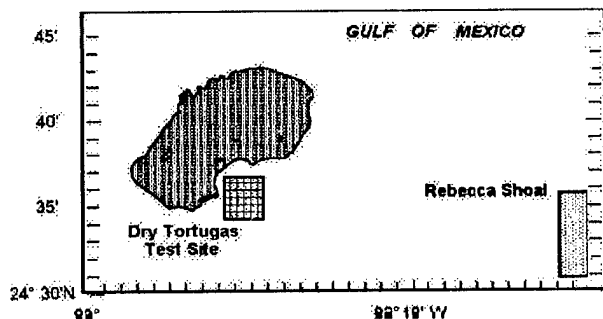


Fig. 1. Dry Tortugas test site used for MTEDS Demo

West Campaign location chart. The lines depicted in the Dry Tortugas test area represent the tracklines of the MTEDS demonstration.

The objective of the sea test was to demonstrate that selected environmental data critical to MCM tactical decision-making could be:

- Measured in situ
- Collected while underway at 4-5 kn
- Stored in an off-the-shelf data base residing within a Navy standard computer workstation
  - Displayed on the workstation screen in real time
  - Used by resident algorithms to predict information of tactical importance to MCM (e.g., mine burial probability and percent of mine buried)

The data collected during this demonstration were:

- Bathymetry using the ship's echo sounder and the ARL:UT collection and processing hardware<sup>1</sup>
- Water Current Velocity profile using a hull-mounted off-the-shelf Acoustic Doppler Current Profiler (ADCP) (manufactured by RD Instruments, Inc.)
- Seafloor Sediment Classification using the ship's echo sounder transducer and NRL's Acoustic Seafloor Classification System (ASCS) processor
- Sound Speed Profile using: (1) the off-the-shelf Aquashuttle system (manufactured by Chelsea Instruments,

<sup>1</sup> The bathymetry recording and processing capability was developed by ARL:UT using funds provided by the Defense Mapping Agency (DMA).

Ltd); and (2) a CTD system (manufactured by General Oceanics)

- SQQ-32 sonar reverberation statistics<sup>2</sup>
- Differential GPS

A second at-sea demonstration was conducted in Onslow Bay, NC on 27-28 April 1996 using the MCM ship USS WARRIOR (MCM-10). The objective of this sea test was to demonstrate that selected environmental parameters could be collected from an MCM-1-class ship using combat sensors normally installed on the ship. The same objectives as the Key West test applied during this demonstration [16]. The environmental parameters collected were bathymetry, sediment properties, and reflection loss using the UQN-4 transducer, bottom reverberation statistics, using the SQQ-32 sonar, and precise navigation using the ship's differential GPS. In addition, CTD lowerings were made, and the resultant sound speed profile data were entered into the data base. It is important to note that in the Onslow Bay test, the ship's minehunting sonar, the SQQ-32, was the only sensor used to collect the quantified reverberation statistics data.

All the objectives of the two demonstrations were met, and a fairly clear picture of the recommendations for transition of an MTEDS capability to MCM ships has evolved. These recommendations are presented below.

### III. RECOMMENDATIONS

#### A. Transition Recommendations

1) Water Column Currents: The commercial RD Instruments, Inc. ADCP tested during this program appears to be a reliable and stable instrument. The particular system chosen (150 kHz, Direct Read) was selected because of the published maximum depth capability of 300 m, which conforms to the criteria set forth in the initial MTEDS design workshops. However, investigation has shown that the most reliable data from this instrument occur to a depth of approximately 250 m [8]. Since the great majority of MCM operations will occur in water depths less than 150 m, a higher frequency (thus shallower depth capability), higher resolution system would provide improvements over the system tested. Therefore, the RD Instruments 300 kHz broadband system is recommended for transition in the near term. This system weighs about 6 kg with a transducer that is 227 mm in diameter and 181 mm in length. This system

<sup>2</sup> The R/V SEWARD JOHNSON was not equipped with an SQQ-32 minehunting sonar; therefore, recorded SQQ-32 sonar data was provided by ARL:UT and played back in real time simulating minehunting sonar operations.

is available with composite plastics, is compatible with various anti-fouling paints, and has mateable underwater connectors. The 300 kHz model provides a profiling range of 5 to 150 m and has a vertical resolution cell of 1 to 16 m, depending on water depth of the cell. This system can provide data in 1 to 128 depth cells at ping rates of up to 5 per sec. This recommended system also requires low power (0.1 to 8.0 W average) and is relatively maintenance free.

Recently, the Applied Research Laboratory at Penn State University (ARL:PSU) has conducted tests on the capability of the RD Instruments 300 kHz system to provide an acceptable bottom track capability [17]. Based on their test results, Barnhoff and Culver [17] concluded that this system can provide accurate estimates of course and speed over ground when the heading remains reasonably steady. Further testing is recommended to determine whether the RD Instruments system is an acceptable replacement for the MK 610 Doppler Velocity Log presently installed on MCM ships.

2) Sediment Classification and Prediction of Impact Mine Burial: Using the MCM ship's AN/UQN-4 fathometer's 12 kHz transducer (TR-192B), the NRL Acoustic Seafloor Classification System (ASCS) provides a reliable system for giving estimates of sediment type and sediment properties which are used for predicting burial of mines on impact. Certainly, the accuracy of the estimates can be improved with a transducer that can generate a narrower beam than the TR-192B. However, in the near term, the following configuration is recommended for MCM ships.

The existing UQN-4 fathometer control electronics should be disconnected from the TR-192B transducer, and the ASCS system should be connected to the transducer through the present cable setup. The ASCS software will then be used to control all functions of the ship's bathymetric system. This configuration can be used to provide a digital readout of water depth on the ship's bridge and anywhere else that water depth readings are required. With this setup, sediment classification data can be collected at sea from the existing transducer while still providing critical water depth information to the ship's officers and crew. Although no real time paper output is presently provided by the ASCS, this function could be integrated into the system, if desired. The output from the ASCS, which includes sediment type, mine burial potential, and selected sediment properties, can be sent in real time to the ship's TAC-3/4 computer (or any future MCM Tactical Decision Aid (TDA) system) for plotting and/or inclusion into a data base for storage and use by algorithms requiring the information. The data can also be transmitted to any other user (ships, ground facilities, Naval Oceanographic Office, etc.) via the Navy standard C<sup>4</sup>I system.

Although the ASCS is presently not a so-called turnkey system, it can be configured to provide a turnkey capability for MCM purposes. All the system's controls are contained in the software and can be preset for a standard MCM operation. However, it is recommended that a capability be provided which will allow an operator to produce near real time mine burial potential maps while on-scene. This latter capability can be incorporated into the near term configuration as recommended, or can be integrated into any planned MCM TDA.

The above near term recommendation is based on the assumption that the present UQN-4 bathymetric system will not be replaced in the near future. There is the potential, however, that the Hydrographic Data Recording System (HDRS) capability being developed by ARL:UT (a Defense Mapping Agency-sponsored program) could be incorporated onto MCM ships to provide a mapping capability in shallow water areas. During the MTEDS demonstrations conducted off Key West, FL and on the PURPLE STAR MCM exercise off North Carolina, the HDRS system used the UQN-4 to provide the bathymetric data needed to generate bathymetry maps. The raw output from the HDRS was ported directly to the ASCS to be recorded, displayed in real time, and used to estimate sediment properties and mine burial potential. This technique was used successfully on two separate sea trials and can be integrated into the MCM ships with no significant development efforts.

The present ASCS hardware configuration consists of two PC desktop workstations, a power amplifier, and a printer. Because of space constraints on MCM ships, it is recommended that the present configuration be combined to utilize one workstation, perhaps a laptop computer with a docking station, which allows a selection of displays including a go/no go color map format depicting mine burial probability, a system information text display, and a trackline plot of sediment type and/or mine burial probability. With respect to the latter, the same go/no go color scheme can be used as the map display.

3) Bathymetry: The ability to use the AN/UQN-4 Navy standard echo sounder to provide a digital record of bathymetry in shallow water has been clearly demonstrated on the MTEDS program. Furthermore, the information collected from this system: (1) is used by the NRL ASCS for determining sediment type, properties, and mine burial potential; and (2) provides acoustic reflection loss. Once several gridded track lines are run in an MCM objective area, maps of the above parameters can be generated. A point of note on this issue, and discussed above, is that the data logging functions can be accomplished without interfering with the normal operation of the echo sounder.

To provide this capability to the MCM ships in the near term, it will be necessary to design and build a data collection unit and to modify existing software to meet the necessary military standards. This unit would be small (briefcase size) and would be installed in the MCM ship's chart room. Wiring to connect this unit to the tactical computer in CIC will be required.

To enhance the capability to determine sediment classification using NRL's ASCS discussed above, it is recommended that a calibration test set be developed to allow rapid calibration of the echo sounder at the pier. This unit would be lowered over the side, and the sensor would determine acoustic output and receiver sensitivity of the echo sounder.

4) Bottom Reverberation: The MTEDS program demonstrations showed that the reverberation field generated and sensed by the AN/SQQ-32 mine hunting sonar can be quantified and logged. The data logging functions evolved from the test and development algorithms used in the performance evaluation studies. Furthermore, it was shown that the logging functions could be achieved without interfering with the normal operations of the minehunting sonar.

To provide this capability to the SQQ-32-equipped MCM ships in the near term, it is recommended that a data collection unit be designed and built and that the present software be modified to meet necessary military standards. This data collection unit could be located in the "lower sound" area of the MCM ship. Wiring from the data collection unit to the tactical computer in CIC will be required.

In the longer term, it is recommended that the capabilities of the data collection unit be integrated into the sonar itself as part of the Pre-Programmed Product Improvement (P<sup>3</sup>I) program of the SQQ-32 sonar.

5) Water Column Properties (Sound Speed and Visibility): During the MTEDS program, an off-the-shelf system manufactured in the United Kingdom was used to test the concept of collecting a sound speed profile while underway. This system, as configured, had limitations for meeting the MTEDS requirements [9]; the towfish required speeds of 10 kn or greater, the fish had to be deployed and towed from the stern, and deeper depths than our test area (30 m) were desired for deployment. The latter restriction was imposed by NRL scientists not wanting to "ground" the fish into the bottom due to their unfamiliarity in using the newly-acquired system. However, despite these limitations, the concept of collecting sound speed data while underway,

storing the data in a database, and using it for tactical purposes was clearly demonstrated. During the period that the MTEDS program was conducted (Aug 92-Sep 95), new commercial systems able to meet the MTEDS requirements were developed. One particular system manufactured in Canada appears to offer many advantages over the system tested. This system can be deployed and towed from the side of the ship at speeds from 0 to 25 kn. The winch component is computer-controlled with automatic deployment and recovery, thereby providing deployment on command with minimum involvement by the ship's crew. It is recommended that an effort be conducted which evaluates the capabilities of this system relative to meeting MCM requirements for providing a sound speed and a water visibility profile while underway for use in real time.

The Canadian system is being suitably modified to operate in water depths of 200 m or less and is being configured with CTD and optical sensors. This system includes a free-fall fish, winch and conductor cable, boom-overboarding sheave, docking chute, hydraulic system, and a control/data storage system. All components except for the control/data storage computer would be installed in a single base structure with dimensions of 123 by 98 cm. Approximate weight of this component would be approximately 273 kg. The single base structure is suitable for deployment off either side of the ship.

6) Electrical Properties of Water Column and Sediments: Presently, the US MCM force relies on Magnetic Capability and Safety (MACAS) surveys to provide the electrical/conductivity parameters of the water column and sediments needed to determine the swept path width of its magnetic mine sweeping equipment. The MACAS surveys are expensive, time consuming, laborious, and sometimes not possible due to political denial of access to key littoral regions of the world. Therefore, use of such a capability as NRL's Airborne Electromagnetic Measurement (AEM) system, which can collect the required data by helicopter at 90 knots, in areas too shallow for most deep-drafted survey ships, and which does not require an in-water sensor (the AEM sensor is a "bird" rather than a "fish") is highly desirable.

During the MTEDS program, co-located data were collected by NRL's AEM system and the Naval Oceanographic Office's MACAS system to address the feasibility of using the AEM measurements to provide MACAS-comparable data. Comparisons of the resulting data sets demonstrated that the AEM has great potential for replacing MACAS [4]. Although it was shown that the AEM can acquire reasonable average estimates of the MACAS parameters along profiles which are needed to determine magnetic swept path (differences of 2 to 6

percent were observed), various uncertainties in comparing the co-located data forced the conclusion that the AEM technology needs further testing. These differences can be a result of one or more of the following: (1) the AEM has lateral resolutions of 50-100 m while MACAS has resolutions of 1-1.5 km; (2) penetration depth limitations constrain use of the AEM technique to a water depth of less than 30 m where MACAS is operational to 60 m; (3) MACAS provides constant conductivity along each profile and AEM provides continuous conductivity; (4) different system noise characteristics exist due to potentially higher platform motion of the airborne AEM system which can result in lower signal to noise ratios for the AEM data than that provided by the more stable MACAS measurements; and (5) MACAS requires a single-step processing inversion for the current environmental parameters while AEM requires a 2-step interpretation (a three-layer physical model is first constructed and then transformed into the MACAS model). Although it is likely that the AEM capability is superior to the Navy-standard MACAS survey approach for water depths less than 25-30 m, further research and testing is needed to increase the fundamental understanding of AEM/environmental interactions (e.g., frequency response inversion stability in various geologic settings under realistic noise conditions) to clarify relationships between MACAS and AEM results over a variety of sediment types. In addition, it has been validated that the AEM can accurately measure water depths and water conductivity over several coastal environments and this information alone can provide valuable information to estimate first order environmental models. Therefore, AEM has the potential of providing the critical environmental information needed to assess MCM sweep performance in many portions of the world that are currently unavailable; thus, the AEM technique is highly recommended for further, long term development.

#### *B. Recommended Additional Testing*

1) **Water Column Currents:** The 150 kHz, Direct Read Acoustic Doppler Current Profiler (ADCP) system manufactured by RD Instruments was used for testing during the MTEDS program. Based on the results of these tests, it is recommended that the 300 kHz system be used in the near term. However, although the 300 kHz system is a commercial off-the-shelf item, it is recommended that it be tested at sea in typical littoral waters likely to be involved in future MCM operations.

In addition, even though recent tests by Barnoff and Culver [16] show that the 300kHz ADCP can provide accurate estimates of bottom track, it is recommended that sea trials be conducted to determine whether this system is

an acceptable replacement for the MK 610 Doppler Velocity Log presently installed on MCM ships.

In the longer term, the following research transition recommendations are made for consideration: (1) Investigate the potential offered by a specifically designed transducer optimized for the depth ranges of interest to MCM; and (2) Investigate the advantages offered by new developments in transducer design, specifically flat-faced, phased array transducers.

2) **Sediment Classification and Prediction of Impact Mine Burial:** In the present ASCS processing scheme, the storage of the echo strength values is governed by the frequency in use and is user selectable. This method averages the echo return values for the entire bin increment (40 cm at 15 kHz, for example) and provides a stepped impedance sediment column profile which may not account for negative impedance changes in the sediments. A linearized least squares inversion technique has been tested on some ASCS data. The results show that this technique can provide an essentially continuous, more representative impedance profile of the sediment column. This technique will allow more accurate estimates of the sediment physical and mechanical properties, and hence, more accurate estimates of mine burial. An added benefit of the linearized least squares inversion technique is that it will reduce the processing overhead, thereby making the recommended conversion from a two-computer system to a single laptop system with docking station more straightforward. It is recommended that an improvement in the current ASCS processing scheme be made by adding this technique to the processing software. Additional testing of the technique on ASCS data from other environments will be required.

3) **Bathymetry:** As discussed in Section III A 3 above, it was recommended that a calibration test set be developed to allow rapid calibration of the echo sounder at the pier. This capability would provide an enhanced capability to determine sediment classification estimates. This test set unit would be lowered over the side at the pier, and the sensor would determine acoustic output and receiver sensitivity of the echo sounder.

In the longer term, it is likely that the UQN-4 will require product improvement because the present system is obsolete and spare parts are becoming difficult to acquire. As part of this product improvement, if it occurs, it is recommended that the capability provided by the data collection unit mentioned above be included as an integral part of the echo sounder.

4) Bottom Reverberation: In Section III A 4 above, it was recommended that a dedicated bottom reverberation data collection unit be designed and built in the near term. This unit could be located in the "lower sound" area of the MCM ship. In the longer term, it is recommended that the capabilities of the data collection unit be integrated into the sonar itself as part of the SQQ-32 sonar P<sup>3</sup>I program.

It has been recognized that the SQQ-32 system has potential for mapping clutter density. It is recommended that an R&D program be initiated which investigates and quantifies this potential. Comparisons of the SQQ-32 clutter density maps with those generated using high frequency sonars under the NRL High Resolution MCM Environmental Acoustics research program would be very valuable in this investigation.

5) Water Column Properties (Sound Speed and Visibility): In Section III A 5 above, it was recommended that the Canadian MV<sup>2</sup>-CTD system be incorporated onto the MCM ships for providing vertical profiles of sound speed, conductivity, temperature, and depth. This particular system was not tested within the MTEDS program. As with the 300 kHz ADCP system, it is recommended that the MV<sup>2</sup>-CTD be tested at sea in order to be sure that it can fulfill the requirements of the MCM mission.

A technology has recently been investigated which would allow the use of a shipboard laser system to produce an acoustic pulse in the water which can be monitored to provide a sound speed profile of the water column. This technique (called the Remote Sound Velocity Profiler), if feasible, offers many advantages to the MCM force because the all-important sound speed structure can be defined on command without the need to lower and retrieve a sensor from the ship's deck [18]. It is recommended that this technique be evaluated for potential transition to the MCM force.

6) Electrical Properties of Water Column and Sediments: As discussed in III A 6 above, the AEM technique offers many advantages over the now-used MACAS survey approach for providing electrical/conductivity parameters needed to determine magnetic swept path. However, despite fairly close agreement between the AEM and MACAS results during the MTEDS project, too many uncertainties still exist between the results obtained by the two systems. Because of the potential high payoff of using AEM, it is recommended that additional testing between the two systems be conducted in order to more closely quantify the differences and capabilities.

The most straightforward way to resolve this issue is to use a high resolution in-water EM system to cover co-

located traverses of the AEM and MACAS systems and to act as the ground truth for the comparisons. In addition, testing must be extended to include other common littoral environments such as sands, soft muds, and hard, rocky areas. These additional comparisons will resolve the impact/importance of the defined uncertainties given above and will develop confidence in the AEM procedure.

Certain recommended "improvements" to the AEM system include decreasing the EM frequency to 30 Hz and using improved motion sensors to minimize low frequency motion noise.

In the longer term, consideration should be given to exploring the potential of adding an in-water towed EM system to the MCM platforms. Such a system would provide the MCM surface platforms with an organic capability to determine magnetic swept paths, thereby eliminating the requirement for MACAS surveys and helicopter support.

## ACKNOWLEDGMENTS

The MTEDS program was funded by the Office of Naval Research through the Naval Research Laboratory under Program Element (P.E.) 0602435N. The at-sea demonstration conducted during the PURPLE STAR MCM exercise was funded by Oceanographer of the Navy (N096) and managed by ONR Code 32 under P.E. 0603785N, Mr. Eigoro Hashimoto, Program Manager. Funding for the ground truth data collection during the Key West Campaign demonstration was provided by ONR through the Coastal Benthic Boundary Layer research program under P.E. 0601153N, Dr. Michael Richardson, NRL Code 7431, Chief Scientist. We also wish to acknowledge the considerable efforts of the captain and crew of R/V SEWARD JOHNSON operated by the Harbor Branch Oceanographic Institution, Ft. Pierce, FL and the officers and men of USS WARRIOR (MCM-10).

## REFERENCES

- [1] Richardson, M.D. and S.G. Tooma, 1993. "Environmental Requirements to Support MCM Operations in Shallow Water." Journal of Underwater Acoustics 43 (3). pp 977-991. Journal classified SECRET; paper UNCLASSIFIED.
- [2] Naval Research Laboratory, 1992. "Development of an In Situ, Real Time Environmental Data Collection Capability to Support Mine Countermeasures Operations - MCM Tactical Environmental Data

- System (MTEDS) Program Master Plan." Naval Research Laboratory, NRL/AP/7430-92-0001. November 1992. 41 pages.
- [3] **Fleischer, P. and D.L. Lavoie, 1996.** "Ground-Truth Area Selection and Characterization for Mine Countermeasures Tactical Environmental Data System: Final Report." Naval Research Laboratory, NRL/MR/7431-96-8000.
- [4] **Mozley, E. and W. Avera, 1996.** "Airborne Electromagnetic Conductivity Measurements and Transformation for Magnetic Sweep Parameters." Naval Research Laboratory, NRL/MR/7442-96-8027 (in press).
- [5] **Lambert, D.N. and H. Fiedler, 1991.** "Methods of High Resolution Remote Seafloor Characterization." Proceedings of MTS-91 held in New Orleans, LA. pp 1004-1011.
- [6] **Lambert, D.N., J.C. Cranford, and D.J. Walter, 1993.** "Development of a High Resolution Acoustic Seafloor Classification Survey System." In Proceedings of IOA, Vol. 15, Part II. pp 149-156.
- [7] **Hammack, J.A. and C. Brown, 1996.** Database Architecture Development for the Mine Countermeasures (MCM) Tactical Environmental Data System (MTEDS)." Naval Research Laboratory, NRL/FR/7441-96-9662.
- [8] **Brown, R.A., R.W. Meredith, and D.F. Lott, 1996.** "Mine Countermeasures Tactical Environmental Data System: Comparison of Ship-Mounted 150 kHz Acoustic Doppler Current Profiler with Vector Measuring Current Meters." Naval Research Laboratory, NRL/MR/7431-96-7723.
- [9] **Brown, R.A., D.F. Lott, and R.K. Myrick, 1995.** "Mine Countermeasures Tactical Environmental Data System: Demonstration of Real-Time Measurements of Water Column Sound Speed and Clarity." Naval Research Laboratory, NRL/MR/7431-95-7712.
- [10] **Priebe, R.D. and N.P. Chotiros, 1995.** "AN/SQQ-32 Bottom Backscattering Strength Calculations." Applied Research Laboratory:University of Texas, ARL-TR-95-32. Classified CONFIDENTIAL.
- [11] **Chotiros, N.P., 1996.** "Reflection and Reverberation in Normal Incidence Echo Sounding." JASA, V. 96 (5).
- [12] **Lott, D.F. and R.W. Meredith, 1996.** "Introduction to Mine Countermeasures Sonar Performance Modeling with a Survey of Available Models." Naval Research Laboratory, NRL/MR/7431-96-8009.
- [13] **Meredith, R.W. and N.P. Chotiros, 1994.** "Environmental Acoustic Modeling for MTEDS." Naval Research Laboratory, NRL/MR/7174-94-7534.
- [14] **Lohrenz, M.C., P. Wischow, M.E. Trenchard, 1996.** "Environmental Tactical Decision Aid Development for MH-53 Helicopter (MTEDS Task 8): Final Report." Naval Research Laboratory, NRL/FR/7441-96-9661.
- [15] **Tooma, S.G. and M.D. Richardson, 1995.** "The Key West Campaign." Sea Technology, Vol. 36 (6), June 1995. pp 17-25.
- [16] **Lott, D.F. and N.P. Chotiros, 1996.** "Mine Countermeasures Tactical Environmental Data System: At Sea Demonstration During Exercise Purple Star '96." Naval Research Laboratory, NRL/MR/7431-96-8021.
- [17] **Barnoff, M.E. and R.L. Culver, 1996.** "Demonstration of Bottom Track Using an Acoustic Doppler Current Profiler (ADCP)." Applied Research Laboratory:Penn State University Technical Memorandum File No. 96-015, 30 January 1996.
- [18] **Hickman, D.G., J.M. Harding, M. Carnes, and A. Pressman, 1991.** "Aircraft Laser Sensing of Sound Velocity in Water: Brillouin Scattering." Remote Sensing of Environment, 36:165-178.





## **Littoral Remote Sensing**

**Dr. Frank L. Herr**

**CAPT Dennis Ryan, USN**

**Dr. J. M. McDonald**

**Office of Naval Research**

**Ocean, Atmosphere and Space Dept.**

The Office of Naval Research is pursuing a program to develop techniques for clandestine mine countermeasures surveillance and reconnaissance. Central to this program is the exploitation of the National Technical Means to support MCM operations and to provide information on the battlespace environment in fully denied areas. This presentation will outline the development of new products and the demonstration of candidate products during fleet exercises.

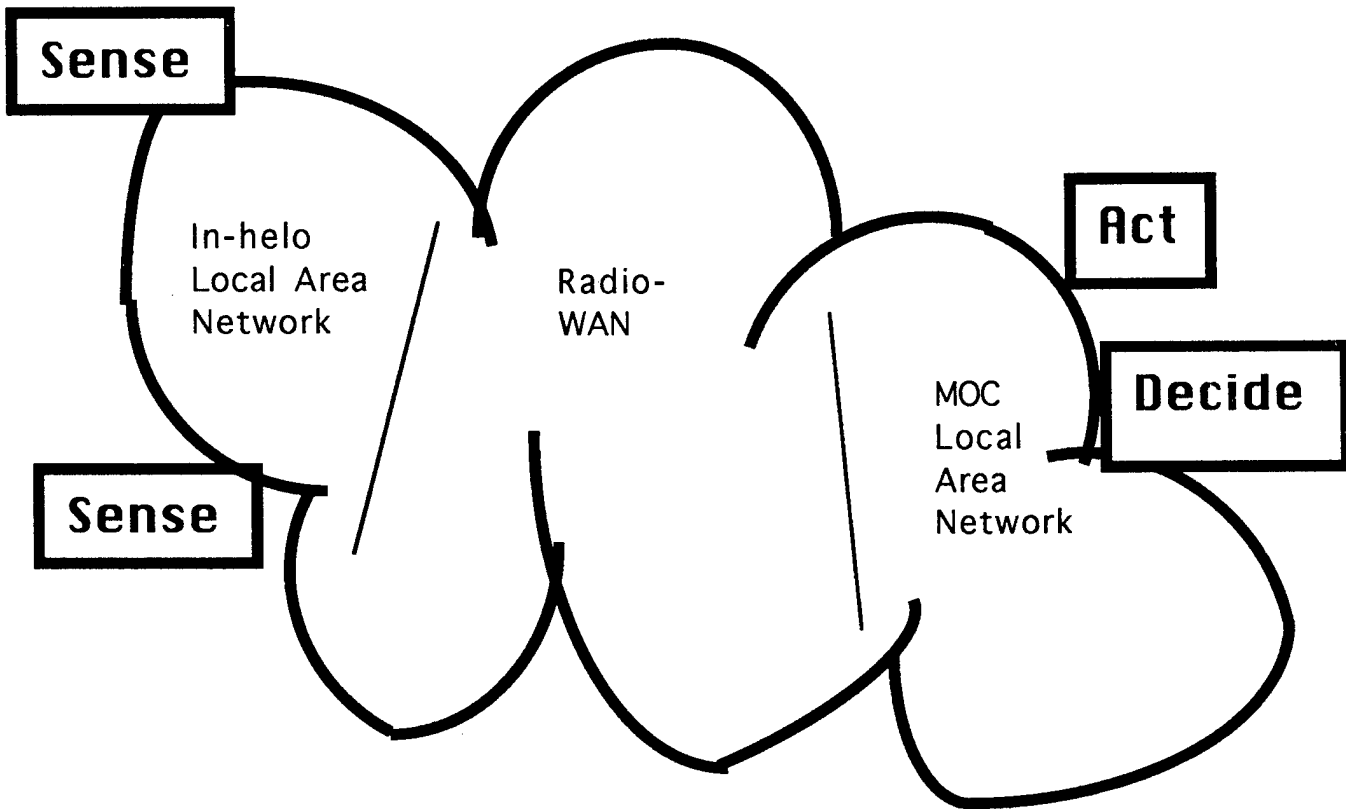
---

Because a full paper was not received by publication date, the above Abstract appears in this Proceedings. The lead author can be reached at the Office of Naval Research, Ocean, Atmosphere and Space Dept., 800 North Quincy Street, Arlington, VA 22217-5660; telephone, 703-696-4125; e-mail, <herrf@onrhq.onr.navy.mil>.



**A Network-Centric  
Information Systems Architecture**

**Rex Buddenberg and  
LT Steve Graves, USN**  
Naval Postgraduate School  
Information Warfare/ITM Curriculum



**Problem. The mine warfare community, particularly the airborne survey component, lacks a means for rapid, automatic data communications. Needed for ability to react to detection of mine-like objects.**

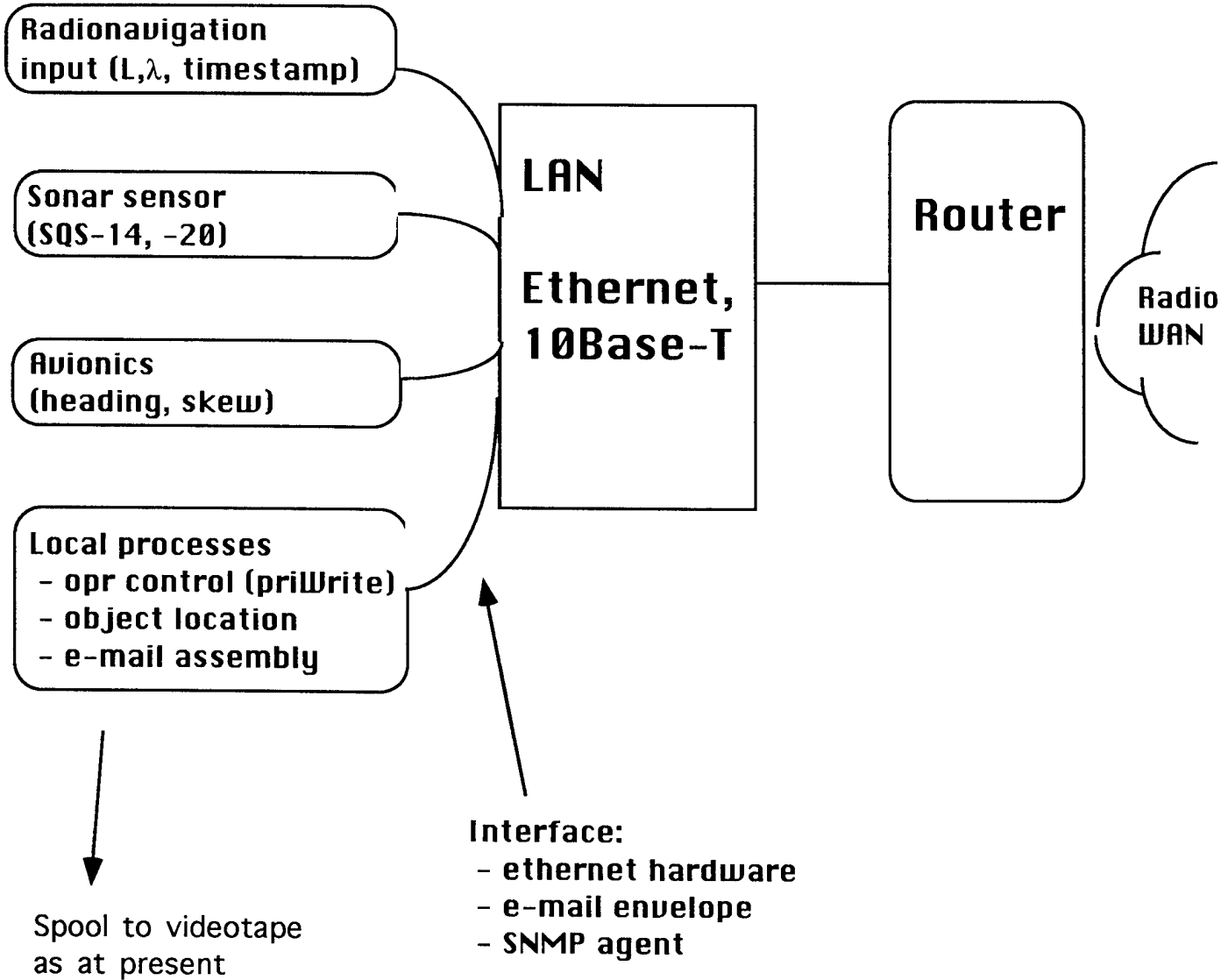
**Provision of such a data communications capability allows**

**1) an in-stride capability to avoid mine invested areas and**

**2) provides intelligence needed to organize mine clearance operations.**

**Systems architecture foundation is network centric one -- sensors and decision support necessary to the mine warfare operation are attached to a tactical internet that is inherently flexible and expandable.**

# MH53 segment



**Currently, the sensor data collected by the survey helicopters is spooled to tape and delivered to the mine warfare operations center upon landing. Any in-flight information is passed by voice radio, which precludes imagery.**

**The proposed layout involves installing a local area network on the mission pallet of the MH53 mine warfare helo which allows the side scan sonar, radionavigation input, helo avionics and local processing to operate on a shared media.**

**Data collected can be assembled into a MIME-compliant e-mail message:**

- timestamp**
- position data (L, $\lambda$ )**
- sonar image (in JPEG format)**
- any ancillary data such as operator identity and flight parameters.**

**This data is assembled by a processor in the helicopter in response either to operator order (Pri-Write) or automated target detection algorithm.**

**Data compression. Key to the systems engineering is understanding that mine-like objects, even in an active minefield, make up a small amount of the ocean bottom. Even accepting a large false-alarm incidence, we gain a great economy by eliminating any requirements to transmit images of blank ocean bottom.**

**This discrimination in only transmitting possible target data far outweighs any additional compression opportunities in applying algorithms (such as those in JPEG) to the images gained, but these are marginal improvements that can also be exploited.**



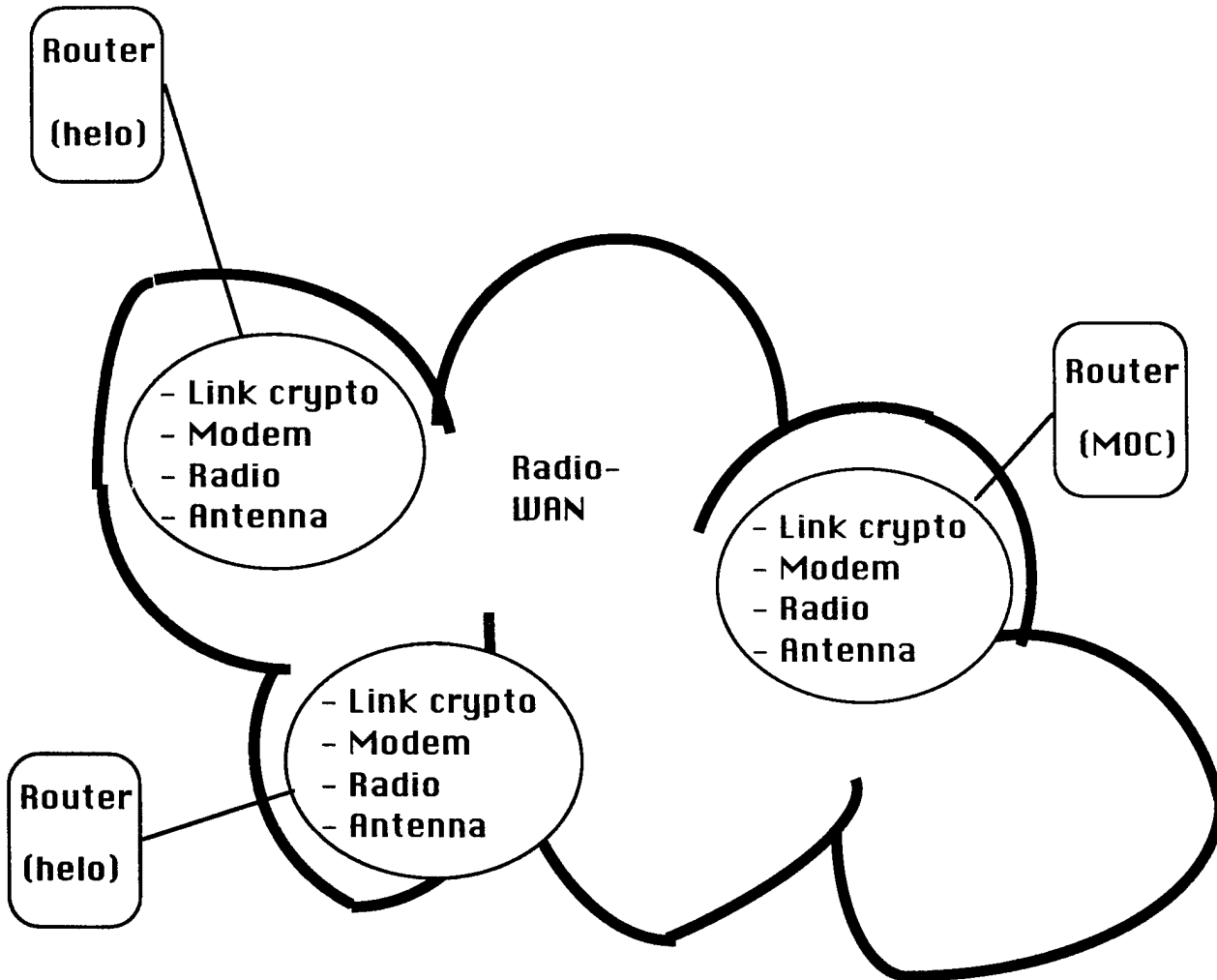
**Interface definition. All the components attached to the helo's LAN (including the sonar) should adhere to a common interface definition:**

- 1. Network interface:**
  - a hardware LAN interface (e.g. ethernet 10Base-T)**
  - an enveloping definition (MIME-compliant e-mail)**
  - a management interface (Simple Network Management Protocol MIB)<sup>1</sup>.**
- 2. Data definition. In addition to the networking interface definitions, a data element standardization exercise is needed for the data elements shown in the table.**

---

<sup>1</sup>One could argue for more detail, but this is complete in that a developer will have a hard time not delivering the rest of the detail if he gets this much right.

# The Radio-WAN



**The radio-WAN segment should be isolated from the in-helo and in-MOC segments using a classical router-based internetwork layout. This allows use of several specific radio-WAN technologies and easy migration to new technologies as they appear.**

**Objectively, any media that can deliver IP datagrams from one router to another will do.**

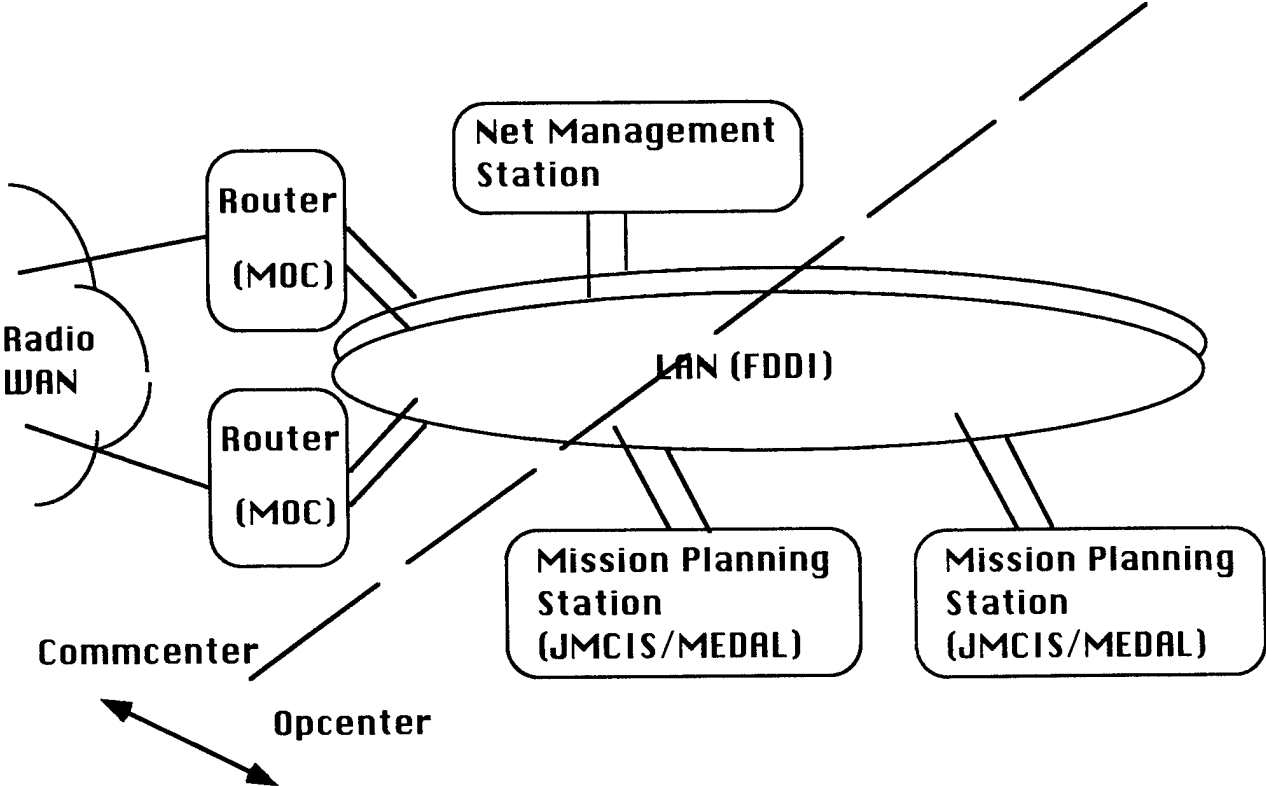
**For this thesis, we used an office-automation wireless LAN for the demonstration as well as the Navy's Battle Group e-mail system to show an HF solution<sup>2</sup>.**

**Future technologies that are easily integratable into this tactical internet architecture include wideband HF, commercial LEO connectivity, and deliverables anticipated from the Navy's JMCOMMS program.**

---

<sup>2</sup>Our Thanks to Terry Danielson at NRaD for loan of some equipment and some coaching.

# Mine Warfare Operations Center (MOC) Layout



**Incoming e-mail messages from the survey helicopters are broken out and the data is filed in the JMCIS relational database in a table resembling:**

- originating unit ID**
- timestamp**
- position data (L, $\lambda$ )**
- JPEG images of mine-like objects (stored as Binary Large Objects, or BLOBs, in database terminology).**

**From this database, operations can quickly**

- 1) assemble the intelligence an operational commander (such as an amphibious group commander) needs to avoid possible mined areas and**

- 2) organize and schedule surface-based clearance operations.**

**Credits.**

**This poster session is assembled from a thesis manuscript by Lt Steve Graves USN. Advised by Don Brutzman and Rex Buddenberg (who assembled this presentation and takes responsibility for any errors).**

# **Information Warfare and the Countermine Problem**

**Edward C. Gough Jr.**

University of Washington, Applied Physics Laboratory

**Robert L. Barrett**

Naval Oceanographic Office

This paper addresses how technologies relevant to Information Warfare are to be organized to benefit the warfighter and how Information Warfare can enable U.S. forces to control combat tempo in amphibious assault, countering the advantages inherent in defensive mine warfare. Drawing on examples from the work of the Applied Physics Laboratory at the University of Washington, the Naval Oceanographic Office, and the authors' recent experience as Science Advisors for the Commander in Chief of Naval Forces Europe and the Commander U.S. Navy Sixth Fleet, as well as other Navy efforts, this paper focuses on how identifying, organizing and using quantitative information about the physical environment supplements Intelligence about enemy strengths and activity to create a seamless picture of the combat environment. Issues include identifying critical information, including environmental variability; technologies for collecting data, including novel uses of military sensors to collect useable environmental data; and emerging technologies for organizing data and distributed processing. The process supports and improves deliberate planning, crisis action planning, development and evaluation of candidate courses of action, and operational decisionmaking in combat. The paper recommends specific action by both the Research and Development and operational communities to support emerging needs.

---

Because a full paper was not received by publication date, the above Abstract appears in this Proceedings. The lead author can be reached at APL, University of Washington, 1013 N.E. 40th Street, Seattle, WA 98105-6698; telephone, 206-543-1300.



# CHAPTER 11: PRESERVING THE MINE/COUNTERMINE EXPERIENCE

## MINING THE HISTORICAL RECORD

George Santayana is quoted saying, "To be ignorant of history is to be doomed to repeat it." And President Harry Truman used the aphorism, "The only thing new is the history that you do not know."

Through a careful study of the history of the use of mines in warfare, one develops both an understanding and appreciation of the strategic leverage that adroit use of mines confers both offensively and defensively.

The United States has a rich history in Mine Warfare. This Chapter combines Symposium papers that deal with recent history with those that seek to capture operational experience for the historical record.

Dr. Tamara A. Smith, whose presentation appears in this Chapter, has called for an institutionalized process by which primary source historical records are preserved. She made the observation, which was one of consensus, that, to our great detriment, historians are becoming an endangered species in the service of the U.S. government. Her especially cogent presentation clearly differentiated between being able to "tell the story" of what happened and knowing the truth about what actually happened through analysis of real data to reach valid conclusions. Dr. Smith's insights struck a chord with most of the attendees, who urged that follow-on policy action was merited. Especially where currently unpopular mine issues are concerned, she said, there is a crying need for real data analysis and refinement to ensure that the "hard truth" lessons are learned, not just the "easy" ones. Her presentation suggested that this might become increasingly less likely unless the current trend of abolishing billets for historians in key commands is reversed. Ms. Susan Bales, Director of ONR's Naval Science Assistance Program, also confirmed this need, as did other presenters.

Another highlight of the Session, which came from "Hap" Hambric -- Project Leader of the Humanitarian Demining Program at the U.S. Army's Night Vision and Electronic Sensors Directorate at Ft. Belvoir -- was the often unreported fact that U.S. use of offensive anti-personnel landmines (APLs) against Iraqi chemical/biological field sites during Operation Desert Storm may have significantly constrained the Iraqis' ability to access and use such weapons against coalition forces during that highly successful operation. This factor must be acknowledged and become a key part of the larger discussion of how restrictions against future use of U.S. APL stocks should be applied.

We are indebted to Mr. Frank Uhlig, former Editor of the Naval War College Review, for chairing this highly productive Session. We shall endeavor to include Mine Warfare History and current field experience in future Symposia.





# **Lessons Learned and Operational Experience in Mine Warfare at Sea**

**Frank Uhlig, Jr.**  
Advanced Research Scholar  
Naval War College

The future rushes upon us with tremendous speed. For a moment it envelops us. We call that the present. Then it goes by and becomes the past. Just like 1864 or 1915, this morning, which only a few hours ago was in the future, now is in the past. It will be there forever.

In this symposium we are focused on the future, That is the right thing to do. But I have suggested that much of the future is already in the past. In their opacity the past and the future resemble each other, though the future is the more dense of the two. As events fall ever farther astern, sight does not grow clearer. Still, much like any mine-fighting operation, with patient labor we can open the channel, or some channels, anyway, between the past and the future, or as we might term it, the "future past." That is my job now.

We will start with a strategic idea: that the purposes of navies in war are only three in number, two absolutes and a conditional. Those absolute purposes are, first, to make sure that friendly shipping can flow and, second, that hostile shipping cannot. The conditional is that, if our shipping can flow, and if it is necessary or desirable, a navy can dare to land an army on a hostile shore, supporting it then and thereafter with fire and logistics.

Shipping includes all commercial ships, all military logistical ships, naval auxiliaries, amphibious ships, and ballistic missile submarines. I include certain naval types in this list because, whatever their precise function, they do not fight for mastery of the sea or any of its parts.<sup>1</sup>

Minelayers and mine fighters, whether they be aloft or afloat, on the surface or beneath it, do fight for such mastery.

I will ask you to keep in mind a tactical insight developed right here at the Naval Postgraduate School by a member of the faculty, Captain Wayne Hughes, U. S. Navy (Retired). This is that the victor in naval combat will be he who attacks effectively first. The minelayer has the advantage here.<sup>2</sup>

And I will remind you of the geographical fact that all deep-sea voyages begin and end in shallow water. Shallow water is where minelayers and mine fighters do their work.

Despite our aversion toward learning anything from those who have gone before us, I am going to examine a few experiences in real minelaying and real mine fighting against real enemies. I do this with the hope that we can learn some things about mine warfare at sea worth that are worth thinking about.

Among the things experience suggests to be worth thinking about are, first, that by themselves mines are unlikely to do much for us or much against us, but that as part of an integrated system, they can be highly effective; second, that intelligence is an important part of that system in both its specific military meaning and in its general meaning; third, that unending persistence is a primary virtue on the part of both the minelayer and the mine fighter; fourth, that it is easier and faster to lay mines than it is to fight them; and finally, that in mine fighting to foist off on civilians or other amateurs work that should be done by professionals is to invite defeat. I will illustrate each of these.

During our Civil War Mobile, Alabama, was a port of destination for blockade runners carrying the goods of war and peace to the Confederacy. In the summer of 1864 the task of the local Northern commander, Rear Admiral David Farragut, was to end that blockade-running traffic. The best way to do that was to seize control of the seaward entrance to Mobile Bay. The Confederates were determined to keep that control for themselves. They had no naval squadron to match Farragut's. But they had two strong forts, Gaines and Morgan, with which to frustrate Farragut's entry. To this, in order to keep enemy small craft out, they added a line of obstacles in the shallow water east of Fort Gaines.

As the water deepened towards Fort Morgan, the Rebels laid a field of mines to keep deep-draft ships out. They kept adding to this field. For the use of the blockade runners, however, they kept free of mines a narrow passage right under the guns of Fort Morgan. Just inside these defenses lay a formidable ironclad warship, the Tennessee.

What did Farragut do? In those days in daylight you could see farther than you could shoot. So the admiral watched where the Rebels planted their mines and noted the position of a buoy they had anchored to help the blockade runners find the safe channel. When darkness fell, so did visibility, often to less than gun range. Then the admiral sent ships' boats into the enemy's waters to find where exactly the mines were, how many there were, what their nature was, what their condition was, and -- note this-- to disarm or sink as many as they could. By first light the boats were on their way back to their ships. The admiral also paid attention to information from escaped Federal sympathizers and deserters. He did not attack until he had all he needed: Troops and boats to land them just outside the forts' gun range; ironclad monitors armed with very few but very large guns, able both to withstand the fire of Fort Morgan and to engage the Tennessee on at least even terms; unarmored but heavily gunned wooden ships with which to help the monitors in their fight with the Rebel ironclad and to support the troops besieging the forts; a partially cleared minefield, and adequate information about the rest of it.

When Farragut began his entrance into Mobile Bay he already had Fort Gaines under siege. He intended to pass through the safe channel near Fort Morgan as swiftly as he could. But almost at once he lost his leading monitor to a mine and, as a result, his wooden column fell into disarray. Confident in his knowledge that the minefield was mainly defunct he led the rest of his ships through the field unharmed. Thereafter he

fought and captured the Tennessee, fought and captured the forts, and with those accomplishments achieved his objective.<sup>3</sup>

What do we see here on the part of Farragut? By secretly scouting out and partly clearing the enemy's minefield he had attacked effectively first. Thus, when he lost the monitor he was able to overcome the resulting confusion. We see the use of intelligence of both kinds; of persistence on the part of the commander in gaining information about the minefield and in weakening it, in building a force suitable to the need, and --despite sudden loss and confusion among his ships-- first in getting them past and then in overcoming the enemy's defenses. We see the cooperation of all elements of the force in the effort to achieve the force's common objective. Thereafter no blockade runner brought arms to the South through Mobile.

How about the Southern defenses? They were formidable, but each element was on its own. Thus, Farragut was able to concentrate on and defeat each of them one at a time. His was a victory well earned.

Let us move on half a century, to the Dardanelles campaign early in 1915 during the First World War. The French, the British, and the Russians were at war against the Austrians, the Germans, and the Turkish, or Ottoman, Empire. With the intention of seizing Constantinople, capital of that empire, London sent a strong naval expedition into the narrow strait leading from the Mediterranean toward that objective. The British knew that the Turks had fortified that strait, and knew where the forts were, so they brought battleships with which to overcome them. They also knew that the Turks had planted mines in the channel, but did not know exactly where those mines were. Still, they did think to bring minesweepers. Unfortunately for them, the minesweepers were merely chartered fishing boats too weakly engined to make effective headway while sweeping for mines against the current. With hulls deeper in the water than were the mines they were supposed to sweep, they were in danger of becoming those weapons' first victims. Even worse, their crews were not professional naval officers and men, but hastily uniformed fishermen under a limited contract. The contract said nothing about sweeping mines while under enemy fire.

The British also had an army, but the powers in London had dispatched their fleet before the army was ready to land. So the British fleet entered the strait, fishermen in the van, fighting men astern. Then, finding themselves in the midst of a field of mines, finding enemy shells bursting all around them, the fishermen fled. Naval officers condemned them as cowards. Later the British Navy did as it should have in the beginning, and manned the makeshift minesweepers with regular officers and men.. But the minesweepers still could not clear the well-defended fields, and they were still unsure exactly where the mines were. Meanwhile, unnoticed by the fleet commander, the persistent and perceptive Turks, having noticed the practise of the battleships to shoot from a spot of calm water outside the main current, planted a new mine field in that spot.

In one day the Turks' new minefield sank three battleships and damaged another, as well as a battle cruiser. The fleet's advance on Constantinople halted temporarily, and never resumed. Later, the British landed their army, at a place called Gallipoli. That army might have outflanked and taken the forts, making it possible for the minesweeping to resume. But by that time the Turks were ready for them and the army got nowhere. Indeed, it was not until years later, when the war had ended, that any British soldier or sailor set foot in Constantinople.<sup>4</sup>

Clearly, it was the defending Turks who attacked effectively first. It was they who used intelligence effectively. It was they who conducted mine warfare with persistence. It was they who integrated their minelaying, their defensive forts, and their field army. The British did nothing comparable. They earned their defeat.

But, making good use of bad experience, the British Navy did learn. In the great sea war in the Atlantic, German U-boats were threatening to halt the flow of British and Allied shipping. But long before the war's end British naval officers and men manning specially designed minesweepers were keeping British channels clear of enemy submarine-laid mines, while British-laid mines came to sink more U-boats than any other weapon the Allies had. Those minelayers and minesweepers were components of an integrated system for the protection of shipping of which convoys were the best-known part.<sup>5</sup>

When peace came the British Navy did not forget what it had learned. When war came again in 1939 the Germans once again began to lay mines. But no matter what form those mines took, moored or bottom dwellers, air-launched, surface launched, or submarine launched, contact, magnetic, or acoustic, the British Navy kept them in check. Only the pressure mine proved too much for Britain's mine fighters but that mine came too late in the war to matter. Meanwhile British mines, most of them laid by RAF Bomber Command, effectively, if expensively, devastated German sea traffic on the western coast of Europe from Spain to Norway, and in the Baltic.<sup>6</sup>

That mining campaign, though not well known in this country, is worth attention. In 20,000 minelaying sorties over a period of five years RAF Bomber Command, at a loss to itself of 450 aircraft, sank 638 German, Finnish, or neutral ships. In comparison, over the same period RAF Coastal Command, employing torpedoes, bombs, and rockets, required 38,000 sorties (and in them lost 857 aircraft) in order to sink 366 ships. British submarines and surface ships sank 196 Axis merchant ships during the same period. Clearly, the British had not only learned, but also retained, both the minelaying and mine fighting lessons of the disaster in the Dardanelles and, with the use of new materiel, that is, aircraft and influence mines, had applied them to their new situation.

The mining campaign was successful, if barely so, because the British used their intelligence effectively: Ultra was with them; they were persistent; they took advantage of darkness; and the minelayers' efforts profited from Coastal Command's simultaneous attacks on German shipping, the attacks on German cities by both Bomber Command and the U. S. Army Air Force, and the great struggles ashore, mainly on the eastern front. The

demands all these placed on German defensive resources left too few to cope effectively with the minelayers. Still, even on the last day of the war, in the Baltic German ships managed to voyage successfully.<sup>7</sup>

It is plain that, though not all navies have shown they can do it, one, at least, has shown that it can learn from its own bad experiences.

Consideration of the sea mining efforts in the two world wars and since show that about one half of them, for example, the German minefields which in 1944 fouled the sea approaches to the beaches of Normandy and the Iraqi minefields which in 1991 foiled any possible American attack by sea upon the Kuwaiti shore, have been defensive. The others, such as the American minefields laid by Army Air Force B-29s in Japan's coastal and inland waters in 1945 and the minefields laid by American carrier-based aircraft which closed the North Vietnamese port of Haiphong in 1972, were offensive in nature.

For almost all minelaying operations, there was a corresponding mine fighting operation. Only at Haiphong was there none, until after the peace treaty was signed, when the United States swept its own fields. For every offensive minelaying operation, the mine fighting effort was defensive, for every defensive minelaying effort, the mine fighting operation was offensive.

Because sea mines are laid not indiscriminately but-- if they are to be effective-- with precision, and in a not very large patch of sea, the mine fighters also work in a not very large patch. Since, if the field is well placed it will be profitable to reseed it persistently, the mine fighters are likely to work their own small patch for a long time. The presence of ship counters in mines simply emphasizes that fact.

As a result of this very localization of mine fighting and the fact that most of it is done not far from some shore (and thus, not far from some haven) mine fighting craft need not be large. Indeed, small as a modern ocean minesweeper is, it is the need for that ship to travel long distances which make it as large as it is. Even so, it is too small and too slow to travel long distances in a timely fashion.

Following upon that fact, among others, and keeping in mind the imperative of attacking effectively first, one looks forward to a complete transformation in the U. S. Fleet's mine fighting materiel, not only to meet the need for the timely arrival of that materiel on scene and ready to work, but also to meet the need for the timely and effective completion of that work. It is on such matters that much of this symposium has dwelt.

Even when these materiel transformations have taken place, we should expect mine warfare to be characterized by persistence and counter-persistence, by the dependence of both sides upon intelligence, and, if the commanders wish their missions to be successful, by the integration of their minelaying and mine fighting efforts into the rest of their operations. The commander who is more successful in these ways than his opponent will have put himself in a good position to attack effectively first.

The big question in the future is whether the U. S. Navy will be as willing as at least one other navy has been to transform its own misshapen habits and antiquated attitudes towards mine warfare. Only if the U. S. Navy manages to do this, will the transformation of mine fighting materiel yield the results for which we all hope so much.

When that happens, episodes such as those at Wonsan in 1950 and in the Persian Gulf in 1991 will be firmly in the past. The U. S. Navy will be able to ensure that friendly shipping can flow and that hostile shipping cannot, that it can land an army on a hostile shore, and that it can support that army with fire and logistics for as long as necessary. The Marines will be pleased. So will the Army and Air Force, and all the others who depend on the Navy to do the job for which they built it.

## Footnotes

1. Here and in the preceding paragraph the speaker adapts slightly his own words from How Navies Fight: The U. S. Navy and its Allies (Annapolis: Naval Institute Press, 1994.) 399-400.
2. Captain Wayne P. Hughes, Jr., U. S. Navy (Retired). Fleet Tactics, Theory and Practise (Annapolis: Naval Institute Press, 1986.) xv.
3. Many people, including Alfred Thayer Mahan, have written about the battle of Mobile Bay. For our purposes Tamara Moser Melia has done it best in "Damn the Torpedoes" A Short History of U. S. Naval Mine Countermeasures, 1777-1991 (Washington: Naval Historical Center, 1991.) 1-4.
4. Arthur J. Marder. From the Dardanelles to Oran: Studies of the Royal Navy in War and Peace, 1915-1940 (London: Oxford University Press, 1974. 1-26, 49-50. Paul G. Halpern. A Naval History of World War I (Annapolis: Naval Institute Press, 1994.) 109-115.
5. Halpern, 345-350. Uhlig, 87-88.
6. Stephen W. Roskill. White Ensign: The British Navy at War 1939-1945 (Annapolis: U. S. Naval Institute, 1960.) 47-48, 59, 89-90, 117, 379. Christina J. M. Goulter. A Forgotten Offensive: Royal Air Force Coastal Command's Anti-Shipping Campaign, 1940-1945 (London: Frank Cass, 1995.) 272, 297-298.
7. Goulter, 297-298, 353.

Footnotes for Lessons Learned and Operational Experience in Mine Warfare at Sea, a paper given Wednesday, Nov. 20, 1996, during a conference on "Technology and the Mine Problem," held at the Naval Postgraduate School, Monterey, California.





## **Process Challenges and Examples: A Reality Check**

**Dr. Tamara Melia Smith**  
Military Historian  
President, The Moser Group

The subtitle of my talk today on “Process Challenges and Examples” is “**A Reality Check,**” because I am going to talk today about the way things really are in historical documentation of the naval mine problem as opposed to the way that they probably should be. After all, the lessons learned and the documentation collected of our operational experience that we will depend on to solve future technical and tactical problems are only as good as the persons who wrote or collected it. And the solutions proposed in numerous studies of that experience by scholars, analysts, operators and students of mine warfare will only be truly useful if the data collected and analyzed is done so within the constructs of **accurate** knowledge of the individual operations being studied.

As a historian who loves her profession, I am always amazed at the number of people who offer me their condolences on my choice of occupation. If their introduction to the study of history was anything like mine, I understand completely. My high school history teachers were uniformly uninspiring. I never had a teacher who majored in history; in fact every one of them coached sports and required very little but regurgitation of one textbook chapter per week in impossibly easy multiple choice exams. The greatest benefit I received from my first two years of high school history was my improvement at poker, which we played daily in class. I fared better my last two years, drawing the football coach, a Marine Corps reservist,

who kept at least three members of the class awake each day diagraming battles, and, due perhaps to our proximity to Los Angeles, allowed students to turn in historical home movies in lieu of term papers. I learned, in fact, less about history, and more about movie making and how to use the Encyclopedia Britannica without exactly plagiarizing.

College was a vast improvement. As a dual History and Political Science major, I learned the distinct differences between the two professions: Political Scientists collected data data, and data. Historians took the data and made sense of it, putting it in the proper perspective in terms of the time and place, often asking the hard and unpopular questions of their sources that the more politically-correct successfully avoided. Perhaps as a result, when the College declared financial exigency and abolished tenure, the only faculty abruptly fired was every member of the History department, the professors who asked the hard questions. As a beginning graduate student in history, I had difficulty accepting my alma mater's explanation that anyone could teach history, especially as I was immediately asked to help the English and Humanities professors learn to teach history by providing them with booklists and outlines for their courses.

Being thus well aware of the devaluation of history professionals, I did not enter this profession with any grand ideas of earning a high salary or great distinction. In fact, I only became a historian because of Katharine Hepburn's screen portrayal of Eleanor of Aquitaine. While directing a scene from The Lion in Winter, I happened to see the movie and was immediately entranced by Hepburn's success in getting into the heart and soul of her character. Reading Amy Kelly's classic biography of Eleanor showed me that a really good historian could indeed understand and relate the reality of the past in a way that it affected future

generations' understanding. After a brief flirtation with medieval history, I settled into the serious study of military history, and of the military mind, through a long and valuable apprenticeship editing the Papers of Ulysses S. Grant.

After leaving graduate school, I was offered positions by universities and several of the services, and turned down the opportunity to be one of almost 400 historians of the Air Force and almost 250 of the Army to take a position as one of the Navy's 16 historians, all civilians. After five years writing and editing 19th century Naval history, I was asked to transfer to contemporary history, becoming one of seven historians tasked with studying the post-World War II Navy. I chose as my topic the Navy in the Pacific and Indian Oceans just in time for the mining of Bridgeton, which quickly catapulted me into the study of mine warfare. I was asked by the then Director of Naval History to undertake a short history of U.S. Naval Mine Countermeasures. I was pleased that he thought me so capable until years later when he admitted he did so because he considered mine warfare a suitable subject for a woman historian, and that he would never have given the assignment to a man. He did not mean that as a compliment.

While writing this book, I was named the first historical Fleet Liaison, charged with deploying to discover more effective ways to document modern naval operations, a position I held for the next 5 years. But by the time I completed my history of mine countermeasures, "Damn the Torpedoes," the new Director of Naval History declined to publish it. For almost two years I checked, rechecked, and reproofed footnotes, sought input and critical advice from naval and military scholars and officers versed in mine warfare, and made many concessions to finesse wording demanded by my superiors, who had difficulty with the idea of publishing

anything even remotely critical of the Navy. I finally requested that the manuscript be released to me for private publication. The mining of Tripoli and Princeton a few days later quickly changed the situation, and the manuscript was put into immediate production.

If not for the tragedy of the mining of these two ships in Desert Storm, I have no doubt that you would probably have never heard of me, or this book.

This experience made it clear to me that not much has changed in improving the estimation of history and historians, even among those who uphold the finest traditions of their military service. In general, Americans do not study history as a useful tool for the future. We continue to believe that as Americans we are special. We intrinsically believe in the theories popularized in Horatio Alger myths and John Wayne movies, a pull-them-up-by-their bootstraps fantasy that as Americans, if we work hard we will own the future without needing the Old World's ties to remembering the past. This conception has grown even more marked since we have proclaimed victory in the Cold War. In the last two years federal historical programs have experienced a severe decline. Two years ago Newt Gingrich became the first Speaker of the House to hold a Ph.D. in history, and the first to fire the House Historian, replacing him with a political scientist. Last December the Historian of the Internal Revenue Service resigned in protest of the IRS's refusal to save documentation crucial to any understanding of its operations, in violation of federal statutes. Historians throughout the government are being downsized, myself among them, and historical positions in universities are remaining vacant at a rate which suggests to me that America continues to find it's understanding of history expendable.

We do not often pay attention to the real lessons learned in our successes or failures

because we insist on viewing history as the art of looking backward, rather than what it truly is: the science of tracing our footsteps to understand why we stand where we are now. The real art of history, mainly, is in adequately using this science to prepare us to face the future.

**History does not repeat itself.** But as Shakespeare put it, "What's past is prologue." And every few years someone proves Santayana's prediction that "those who cannot remember the past are condemned to repeat it."

The Navy, like the nation, sees history as trivia. The first, last and best are highlighted, with high priority on those "Bicentennial Minutes" of trivia which can be mastered in a few sound bites; few indeed see history as of much use to future operational scenarios. This national myopia is not shared by the other services and many other nations, who put more resources into the study and preservation of their history, all of whom allow their active duty officers to obtain graduate study in history at government expense, and who are expected to take an active part in writing, teaching and preserving their services' history. Third World countries today have witnessed recent history and realize that mines can be an effective tool in stopping their enemies, and are increasingly preparing to use them. U.S. defense leadership, on the other hand, seems to have "learned," particularly over the past decade, that mines do not stop U.S. operations no matter how much damage they inflict on ships and people.

So, what good is history anyway? Can having an adequate understanding of your past operations help meet the needs of the modern military? And what do historians do that can be of use to the Navy?

One legendary historian, also a naval reservist, defined our work succinctly as "reading

other people's mail," but it is much more than that. Historians collect data, and the good ones find the right questions to ask of their sources to reveal what really happened. Good historians are also good analysts, who can find the useful lessons of the past to illuminate the mission needs of the future. The data they collect, especially during an operation, can be the right kind of data needed to justify new systems and improve future capabilities, the kind that is often overlooked by others.

I emphasize good because as in all professions, there are good historians and bad ones. Bad historians, by my definition, fail to look for the right data to make an objective judgment, or decide what they want to prove first, then look at the data with an eye towards proving their own thesis, right or wrong. The good ones take the more painstaking approach of reading all the data and conducting all the interviews first, without prejudice, before determining what they believe are the real lessons learned. This is not as easy as it sounds. In German, there is a better distinction of this process in terminology. Bad historians can tell you about "historie," or the story of what happened, while good historians seek to find "Geschichte," the truth of what happened.

The difference between the two can be stark, and in our own lifetime we have many examples. Although millions of people witnessed the assassination of John F. Kennedy in person or on film, the testimony of those same "eyewitnesses" have spawned dozens of theories about what actually happened. More recently in my own experience collecting oral histories of persons who witnessed actions surrounding the shoot down of the airbus in the Persian Gulf in 1988 reminded me with deadly certainty that many eyewitnesses to any incident can honestly believe that they have seen the opposite of what actually happened.

A good historian does not trust numbers, calculations, planning documents, message traffic, the impressions of others, or sometimes even their own senses. Instead they try to avoid preconceptions and to ask the right questions and, like a good detective, asks them over and over again to each source to see if the answers differ. It is a time-consuming, exhaustive process that ultimately yields the best analysis over time.

What historians can do for mine warfare is to assist in the collection process to make certain that the operational data collected is useful both for determining the status of current tactics and technology, but for future interpretation as well. There are three elements required for making data useful for both real-time analysts and future historians:

The first is proper, definitive collection of key data in real time. The second is a centralized archival organization of mine warfare documentation. The third is access and timely declassification.

In terms of data collection, operators and operational staffs cannot be expected to properly document the operation with an eye toward future analysis. As the old saying goes, "When they're fighting, they ain't writing." Properly collecting the right data to correctly interpret what actually happened requires a fresh eye from a trained observer. Those expected to document mine warfare operations should regularly deploy in all real-world events, both in exercises and missions, to become an integral part of the mine warfare team. Their mission is not to duplicate the efforts of the technical, scientific and operations analysts assigned to such missions, but to observe what is and is not collected, how the data is collected and maintained, where it will be stored, and to personally collect and archive all pertinent data which illuminate the emerging operation that are not necessarily quantifiable. They will also conduct



oral interviews with participants, seek out the views of personnel at all levels, and pay attention to any questions not asked which may be of future operational interest.

For example, when I deployed during Desert Storm mine clearance operations, my first question to the USMCMGRUCOM staff was, “what have we learned about the Manta mines cleared, particularly in terms of the mines’ actual capabilities and settings?” The answer given was that this data was not being collected, as the Manta line was being hunted by many allied nations. Reconstructing such data is usually not possible: there is no post-mission replacement for being there in terms of getting the right data collected on site.

The individuals assigned to the collection effort should be senior civilians and mine warfare professionals charged specifically with retaining the corporate knowledge of the operations; preferably including at least one professional historian with archival and document control knowledge as well as basic scientific and technical knowledge of the field. Although it would be best to have a historian assigned to each fleet, well-versed in mine warfare, this is not likely to happen in our foreseeable economic future. A good alternative would be to establish a shore civilian billet and centralization of mine warfare’s historical archives to work in conjunction with an established academic research and educational facility with a ready flow of students and naval scholars to work all parts of the problem. The best locations for such a facility would be either here at Monterey, under the aegis of the Naval Postgraduate School, or nearer the fleet in San Diego, under the University of California at San Diego, both of which have the technical and scholarly apparatus by which to collect, store and study both the past and future of mine warfare.

Second, the purpose of having a mine warfare archive is to centralize mine warfare

documentation, which does not mean moving all past documentation to one city, but in wholly embracing the Center-without-Walls concept for mine warfare research. Putting one person or entity in charge of controlling future mine warfare collections as well as keeping track of where all the relevant past documentation is stored requires more expertise than is currently available in any one place. An archivist or librarian can catalog currently known items in a computer database for retrieval on-line by key subject words, but such personnel rarely have the leisure time to actually read the documents and to know their content well enough to direct student research, which could be more effectively handled by a historian. Currently, documentation relative to an understanding of mine warfare operations over the past generation can be found scattered among several different commands and activities, and some key information resides in private collections; a centralized on-line database and future collection and storage efforts can help alleviate the current need for students of mine warfare to travel to literally all parts of the United States to track down the relevant documentation for their research studies. It would also improve the scholarly credibility of their technical studies.

Third, access and timely declassification is crucial to any understanding of the past. With real-time historical collection efforts and a dedicated archival facility, access to mission-related documentation by operational researchers would enhance the ability of students and mine warriors to relate their lessons learned both up and down the chain of command in a much more timely fashion. This current need is, indeed, the main lesson learned of my Desert Storm mine warfare study, still in progress. **True understanding and communication of mine warfare requirements and abilities throughout the Navy was the biggest failure of our mine warfare efforts in Desert Storm, and kept our forces from being fully utilized to**

**the true extent of their capabilities.** It also led to widespread misunderstanding of what, in fact, they did accomplish. Such understanding and communication Navy and DoD-wide can only be accomplished with ready declassification of current documents and studies and a minimization of time restraints on documents in future operations.

Now is the crucial time for an intellectual renaissance in mine warfare. Thanks to the Naval Historical Center, I was able to devote a major portion of my time as Fleet Liaison to studying and documenting mine warfare history. When I went to teach at the Naval War College, the minimal demands on my time as a teacher of strategy and policy left me time to both continue that work in my spare time, and to advise students studying mine warfare in the Operations Department. I am also deeply indebted to RADM John Pearson for funding a year and a half of my research into the extensive Desert Storm documentation collected by and held at the Center for Naval Analysis, which the Naval Historical Center is currently planning to take over. I am no longer employed by the Navy, nor do I have access to my own collection of data from Desert Storm, but I continue to encourage others and assist in their research.

The mine warfare community cannot plan to receive any similar dedication to documenting their work from those currently employed in the established historical programs of the Navy in future. The successive Directors of Naval History have not filled the position of Fleet Liaison since I left it, nor do any of their historians regularly deploy, depending instead on self-taught reservists who have to date brought back from the field a very mixed bag of results. With the appointment of a new Director last year, I had anticipated improvement in the Historical Center's support for the fleet, but the recent selection of their new Senior Historian, who declined to deploy during Desert Storm and who has submitted a manuscript as

the Navy's official history of the operation without consulting the key Desert Storm documents at CNA, leads me to assume that their future assistance to documenting mine warfare issues will be limited at best.

As parents, we always wish, perhaps against human nature, that our children would learn from our mistakes to avoid repeating our own errors in future. We're up against a similar problem here. Mine Warfare documentation cannot be retrofitted. If we want the next generation to avoid some of the traps we've seen in the past, we must stop believing that history is a subject only for arcane scholarly consumption or teachable by any softball coach with a spare class period. We have to do a more thorough job of documenting mine warfare and spreading the word.



# NSAP AND OPERATIONAL EXPERIENCE

by

Susan L. Bales\* and J. Charles Wicke\*\*

\* Susan Bales is the Director of the Naval Science Assistance Program, Office of Naval Research. Previously she was Science Advisor to the CNO Executive Panel and CNO's Trost and Kelso. A physicist, Ms. Bales started her career in naval engineering at the David Taylor Model Basin, Carderock, MD, working in seakeeping and ocean environment modeling and measurement.

\*\* Charles Wicke is a Strategic Planner at the Naval Surface Warfare Center, Dahlgren Division, Coastal Systems Station in Panama City, FL. Previously he was the NSAP Science Advisor to U.S. Navy Mine Warfare Command (COMINEWARCOM). A physicist, Mr. Wicke has thirty years of experience in the research and development of naval systems supporting Mine Warfare, especially in those areas related to underwater acoustics, land mine countermeasures, and mine detection.

## ABSTRACT

**The Naval Science Assistance Program (NSAP) has a 30-year history rich with technical support to naval operational forces that must deal with the mine problem. This paper provides an overview of NSAP and highlights assistance provided to counter the mine problems encountered in Vietnam, the Middle East, and the Adriatic.**

## INTRODUCTION.

During the Vietnam conflict, a program was launched to provide quick-response technical assistance to the Commander, Naval Forces Vietnam. Called the Vietnam Laboratory Assistance Program (VLAP), the program drew upon the expertise of the Navy laboratories to solve a number of new problems associated with coastal, riverine, and special forces warfare. Laboratory scientists and engineers worked side-by-side with Navy and Marine Corps forces to introduce new technologies and to develop tactics for combat situations. Between 1967 and 1972, VLAP participated in over 500 projects, both in the field and in the laboratory.

The success of VLAP at providing rapid solutions to real problems prompted the Director of Navy Laboratories (DNL) to expand this assistance to major naval commands, both ashore and afloat. In June 1970, the Navy Science Assistance Program (NSAP) was established to make available the full spectrum of resources and capabilities of the Navy laboratories to the operating forces. Unique among the services, the Navy retained its in-field scientific advisory program after the conclusion of the Vietnam conflict. The Laboratory Fleet Support Project, initiated in 1975 to make System Command (SYSCOM) resources available to operational forces, was merged with NSAP in 1978.

Figure 1 provides an overview of the genesis of NSAP.

## NSAP TODAY.

NSAP remained under the management of the Naval Surface Warfare Center (NSWC) and its predecessor organizations throughout the 1980s and into the 1990s. As the fiscal realities of the 1990s caught up to the Post-Cold War defense posture of the U.S., NSAP also underwent changes. In October 1994, program management of NSAP was moved to the Navy's full-spectrum corporate laboratory, the Naval Research Laboratory with the program office co-located at and reporting to the

Office of Naval Research (ONR). Historically, this is a significant event because it demonstrates a closer linkage between the Department of Navy corporate Science and Technology (S&T) community and the Fleet and Fleet Marine Forces.

NSAP was renamed the Naval Science Assistance Program in September 1995. Figure 2 provides the mission, vision, and guiding principles of NSAP today. NSAP is the two-way bridge between the operator and the technical community and provides the following:

- On-the-spot S&T Advisors
- Technology assistance to solve real problems rapidly and affordably
- Operator influence on long term S&T investments.

The foremost goals of the program are summarized in Figure 3. Improved support to forward deployed forces, specific technical priorities, and management of the collective knowledge base within the Advisor Corps and Program Office are critical. Emphasis on numbered Fleets, Type Commanders, and Fleet Marines is driving a series of C4ISR, readiness, and maintenance burden reduction initiatives by NSAP. The knowledge base of the NSAP team is being managed by use of an NSAP Web page available to all associated with the program. This Global Technical Tactical Information Center (GTTIC) provides a quick reference to the ongoing issues addressed by the program.

Today, NSAP has S&T Advisors at 29 Joint/Navy/Marine Corps commands identified in Figure 4. The Advisors generally report directly to the Flag and General Officers and deploy forward, both ashore and afloat, as needed. The Advisors are recruited from the naval RDT&E infrastructure noted in Figure 5. During the past five years, Advisors have deployed during a number of real-world crises and conflicts to assist in new tactics development, technology insertions, and to support component commanders during military operations. See Figure 6 for some examples of crisis response support.

## **NSAP PRODUCTS.**

Sample NSAP product lines are given in Table 1.

Each year, NSAP S&T Advisors coordinate the development of Command Technology Issues (CTIs). CTIs are formally approved and prioritized by the Fleet/Force Commanders and forwarded to the NSAP Program Office in ONR. They are structured around the Department of Navy Joint Mission Areas/Support Areas (JMAs/SAs) and provide specific operational deficiencies amenable to technical solutions. These CTIs are the driver for most NSAP investments and are also provided to CNO/N-091 to support the S&T Requirements Guidance generated by the internal Navy/Marine Corps Round Table process. This process will not be elaborated on further here, but it is described thoroughly in Reference 1.

NSAP develops and distributes the "Technologies for Rapid Response" or "Blue Book" for ONR. The Blue Book is a compendium of mature technologies that may contribute significantly to readiness and effectiveness and may impact our tactics and concepts of operations. While not yet thoroughly validated for safety, the technologies are ready for operational evaluation before transition to advanced development and acquisition programs. The Fleets/Forces selected 10 technologies from the June 1995 Blue Book, Reference 2, which are being executed by CINCPACFLT as the executive agent for the CINCs/Fleet Marines. Selections by the Fleets/Forces for the new edition of the Blue Book, Reference 3, have been received and will be inserted in the Fleets/Forces by ONR during 1997.

A summary of NSAP products for FY95, FY96, and planned for FY97 are given in the first "Green Book," Reference 4. It is intended that this document will foster the transition of these products to other theaters, users, and development programs, including IRAD and industrial programs. Ninety-two products are briefly described in the Green Book and are the result of the insertion of mature technologies, systems integration of on-the shelf naval and commercial technologies, advanced demonstrations, analyses, and workshops. Notable products include:

- Extended-life UNREP winch friction drums whose improvement in wear resistance represent more than an order of magnitude improvement.
- Specific Emitter Identification (SEI) ship ID and tracking system, used operationally in the Persian Gulf, in support of Bosnia operations, and for counter-drug work in the Caribbean.
- Concentric Canister Launcher, a low-weight, low-maintenance, inexpensive alternative to VLS, seen as a candidate system for SC21 and the Arsenal Ship.
- Automation of ballistic calculations for naval gunfire by using GPS position data inputs to increase accuracy and decrease effective reaction time.
- An expendable, low-cost, realistic, maneuvering surface target for live-fire self-defense exercising by ships at sea, which has inspired a variety of possible other uses.
- A sniper scope vision-splitter which allows both the shooter and an instructor/observer to see the same image simultaneously, also recording it for later playback during engagement/training reconstruction.
- Major connectivity, compatibility and interoperability improvements in C4I, especially for combined, coalition, and allied operations in the NAVCENT AOR.

Figure 7 provides a summary of products by theater. Forty-eight products were delivered to the Pacific, twenty-three to the Atlantic, five to Europe, nine to Central, and the rest were to other commands. Figure 8 summarizes the products by command type. Twenty-three percent of products supported the Navy CINCs, twenty-five percent the type commanders, eleven percent the numbered fleets, and twenty-six percent the Marine Corps. The numbers of products, by themselves, are not reflective of the impact of NSAP on any single command because some are the results of fairly small efforts, while others are more significant. Figure 9 summarizes the products by JMA/JSA. More than half of the products respond to CTIs which fall within Joint Littoral and Joint SEW/Intelligence-Joint Surveillance.

## **NSAP AND MINE WARFARE.**

Over the past 30 years, NSAP has had a close association with all aspects of Mine Warfare and has supported a Science Advisor at COMINELWARCOM, and its predecessor COMINELWARFORCE, since 1972. In addition to the Science Advisor, NSAP has supported a large number of projects (NSAP tasks) that have supported major military operations. Recent efforts are indicated in the Blue Books and the Green Book. A few historical efforts, in support of major regional conflicts and crises, are traced below.

### **Operation END SWEEP (Vietnam 1973).**

NSAP supported the mining and clearance of Haiphong harbor with a number of tasks such as those identified in Table 2. Before the mining of Haiphong, the National Command Authority required a plan to determine how well the U.S. sweep devices would work against U.S. laid mines. NSAP developed the Destructor Simulator (DST) which provided sufficient confidence to allow the mining of the harbor to go forward. Other efforts supporting END SWEEP determined the hazards helicopters would encounter as they approached mines, navigation requirements for effective sweep systems, and a prediction of the time required to sweep the harbor. The mining of Haiphong harbor is generally considered to have been a pivotal point in the negotiations to release U.S. POWs, especially when the U.S. ceased to sweep. END SWEEP was successful not only from this diplomatic and humanitarian viewpoint, but as well, operationally, as only one mine was detonated during the entire operation.

### **Operation NIMBUS STAR (Suez Canal 1973-1974).**

The conclusion of the Arab-Israeli War found the Suez Canal littered with wreckage mixed with mines and unexploded ordnance. Clearance of the Canal was an international effort lead by COMINELWARFORCE, under the leadership of Rear Admiral McCauley. NIMBUS STAR was an air Mine Countermeasure (MCM) sweep operation. Over 120 square miles were swept in just over a month without a single mine being detonated or any loss of helicopters. NSAP supported the operation with a number of tasks listed in Table 3.



### **Operation EARNEST WILL (Persian Gulf 1987).**

In 1987, hostilities in the Persian Gulf flared, and the U.S. Navy was on-scene to ensure safe shipping and rites of passage. Initially, the only MCM capability in the Gulf consisted of two ocean going tugs equipped with mechanical sweep gear. Figure 10 is a photograph of one of those tugs. The tugs were two converted Kuwaiti vessels, HUNTER and STRIKE. Deploying the sweep gear between them, the tugs lead ship convoys through the waters of the Persian Gulf.

During EARNEST WILL, the IRAN AJR was captured, see Figure 11. Special Warfare forces spotted IRAN AJR dropping mines and fired warning shots to stop the mining. When the Special Forces returned to the scene after a brief absence while refueling their helicopter, the IRAN AJR was laying mines again. After the Special Forces were ordered to stop the mining by any means, they opened fire and the crew of IRAN AJR desisted the minelaying and abandoned ship. At first light, Special Forces boarded the abandoned ship finding the M08, World War I vintage mines shown in Figure 12. Figure 13 shows the simple mine deployment device used with the M08 aboard IRAN AJR. Clearly, any vessel capable of carrying the mines could be used as a mine layer.

Throughout EARNEST WILL, safety of U.S. ships at night was a concern. Figure 14, shows a simplistic triangle of lights placed on the highest decks of the vessels to identify them at night.

NSAP was on scene in the Gulf throughout EARNEST WILL, supporting the sweeping operations and other military activities. The photographs shown were taken by NSAP Advisor Mr. Al Hale.

### **Operation DESERT SHIELD/STORM (Persian Gulf 1990-1991).**

NSAP provided technical assistance throughout the planning, ramp-up, and fighting during DESERT SHIELD/STORM. Advisors were deployed with ground forces and throughout the Gulf, and the Program Office was operational 24 hours a day, relying on permanent civilian staff and naval reserve officers to support the Fleets/Forces. During this period, the COMINSEWARCOM NSAP Advisor worked closely with the Commanding Officers of MCM ships to reduce signatures of those vessels, see Figure 15. NSWC was key to this effort which proved highly effective and lead to a full-fledged signature reduction program.

Throughout DESERT SHIELD/STORM, the threat to surface vessels from floating and drifting mines was significant. To complicate the threat, the mine fields were also contaminated by floating dead sheep, garbage bags, and other debris. The NSAP Advisor demonstrated a mast mounted IR device which was shown to be very effective in distinguishing mines from debris.

As a follow-on effort to the Gulf War, NSAP supported an effort conducted by NSWC to develop a planning simulator for mine clearing operations in the Strait of Hormuz. Matching the threat against MCM techniques, realistic concepts of operation have been developed.

### **Operation JOINT ENDEAVOR (Adriatic 1995-1996).**

During the early days of U.S. naval operational support to NATO efforts in the former Yugoslavia, NSAP initiated a task to provide estimates of potential mine threats in the Adriatic. Estimates of foreign mine performance were incorporated into a model which provides estimates of safe water depth and safe passage near mines, see Figure 16. This was followed by an effort to determine tactics for U.S. helicopters for EOD insertions to neutralize the mines, see Figure 17. Both of these efforts were conducted by NSWC, and the tools have been transitioned to the operators.

## **SUMMARY.**

We have provided a summary of the Naval Science Assistance Program (NSAP) and technical assistance provided to solve mine problems over the last 30 years. The real success story resides in the NSAP S&T Advisors with their technical know-how, willingness to go forward in harm's way, and ability to leverage the entire naval technical enterprise both quickly and effectively. Their on-the-spot influence on operational readiness can not be found elsewhere in the Fleets/Forces.

A number of historical references were used during the preparation of this paper and are given in Table 4. Acknowledgments of individuals who contributed to results reported in this paper are in Table 5. Additionally, the NSAP tasks mentioned throughout were generally performed by the Navy labs, warfare centers, and universities. Additional information regarding the NSAP tasks identified in the Figures and Tables can be provided by *nsaphist@nemo.nosc.mil*.

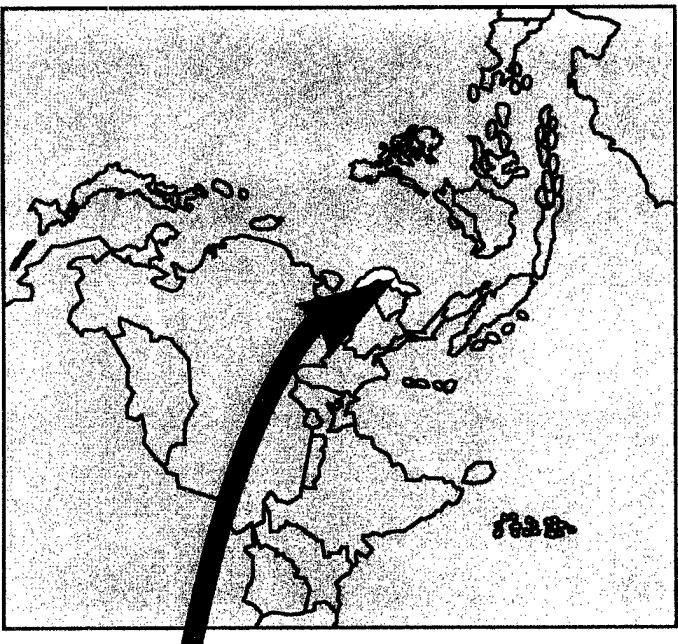
## REFERENCES.

1. "Science and Technology Requirements Guidance," Department of the Navy, Office of the Chief of Naval Operations, Director, Test and Evaluation and Technology Requirements (N-091), June 1996.
2. "Technologies for Rapid Response," Office of Naval Research, June 1995.
3. "Technologies for Rapid Response," Office of Naval Research, June 1996.
4. "Products for the Operational Forces," Office of Naval Research, Naval Science Assistance Program, December 1996.

FIGURE 1 - OVERVIEW OF GENESIS OF NAVAL SCIENCE ASSISTANCE PROGRAM (NSAP)

## Background

- Origins
  - VLAP (1966)
  - NSAP (1970)
- Structure
  - advisors
  - direct command-lab comms
  - state-of-the-art, fast response
  - process ↓, cost ↓, return ↑



• From Hot War to Cold War . . . & Beyond

FIGURE 2 - MISSION, VISION, AND GUIDING PRINCIPLES OF NSAP (1996-1997)

*Provide immediate technical support to enable affordable and decisive military capability*

## **Vision**

*To be at the “tip of the S&T spear” while serving as a bridge between the warrior and the technologist*

## **Guiding Principles**

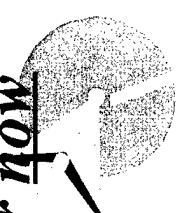
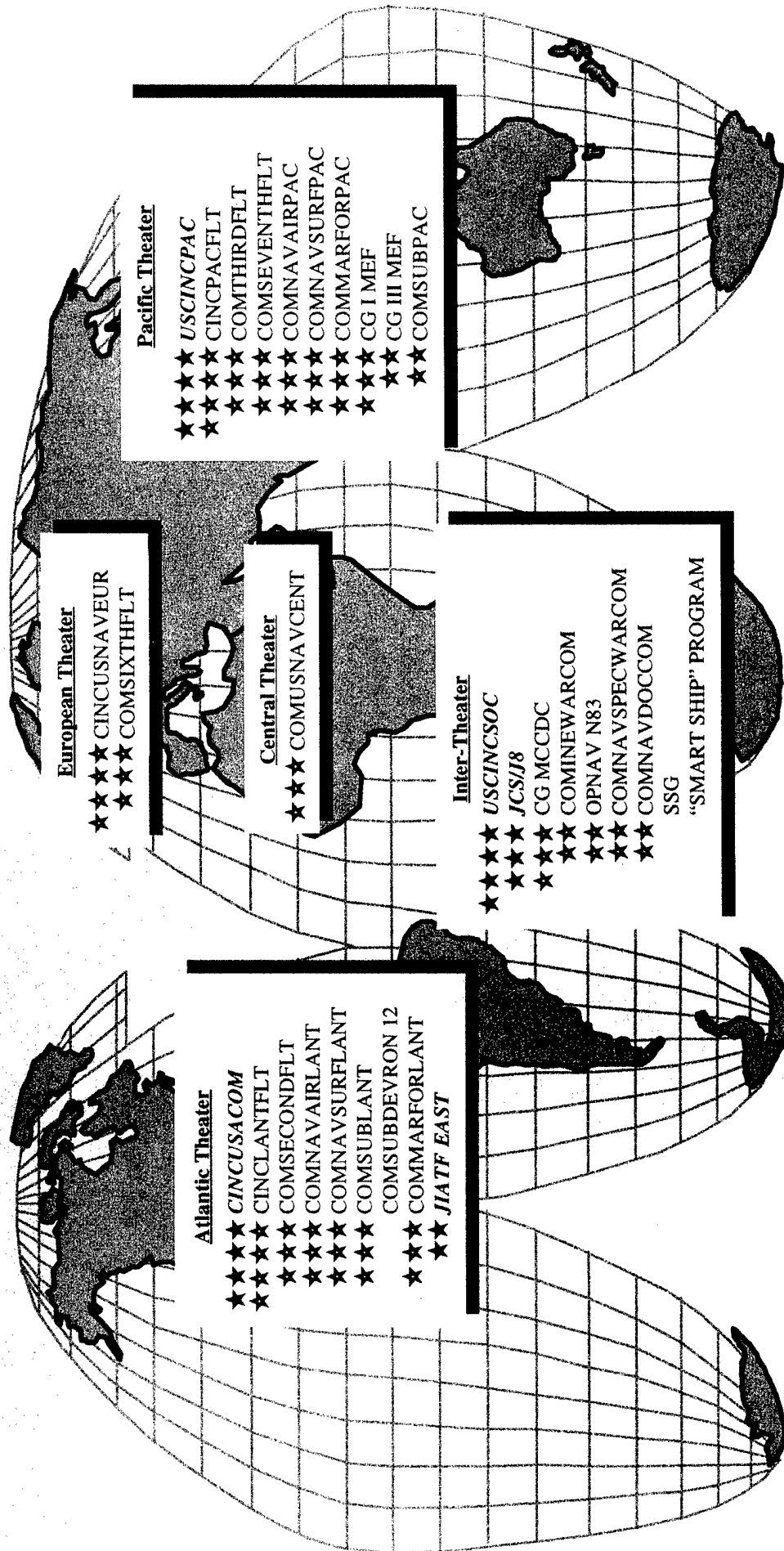
- “Requirements pull”
- Quick, affordable, and “good enough” for now 
- Leveraging through partnerships
- Influence S&T investments to include the near term
- Tech competence, knowledge, drive, integrity
- Find the right people and give them the right tools
- Develop cadre as unique asset to RDT&E infrastructure

FIGURE 3 - NSAP STRATEGIC GOALS (1996-1997)

- *Improve capabilities of forward-deployed forces*
- *Pursue specific technical priorities*
- *Manage collective knowledge*
- *Expand, improve NSAP recruitment, selection, performance*
- *Capitalize on technical insertion/evaluation experiences*

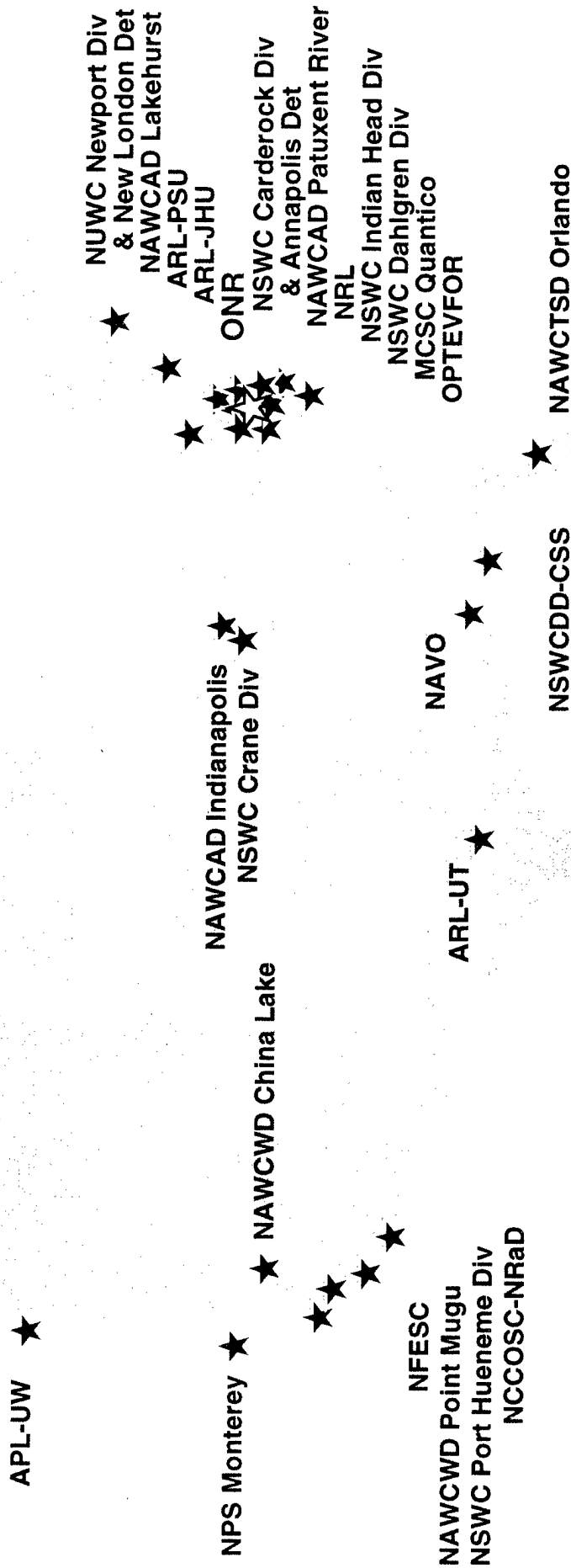
FIGURE 4 - JOINT AND NAVAL COMMANDS SERVED BY NSAP DURING 1996-1997



★★ Indicates Joint Command  
 ★ Indicates Naval Command

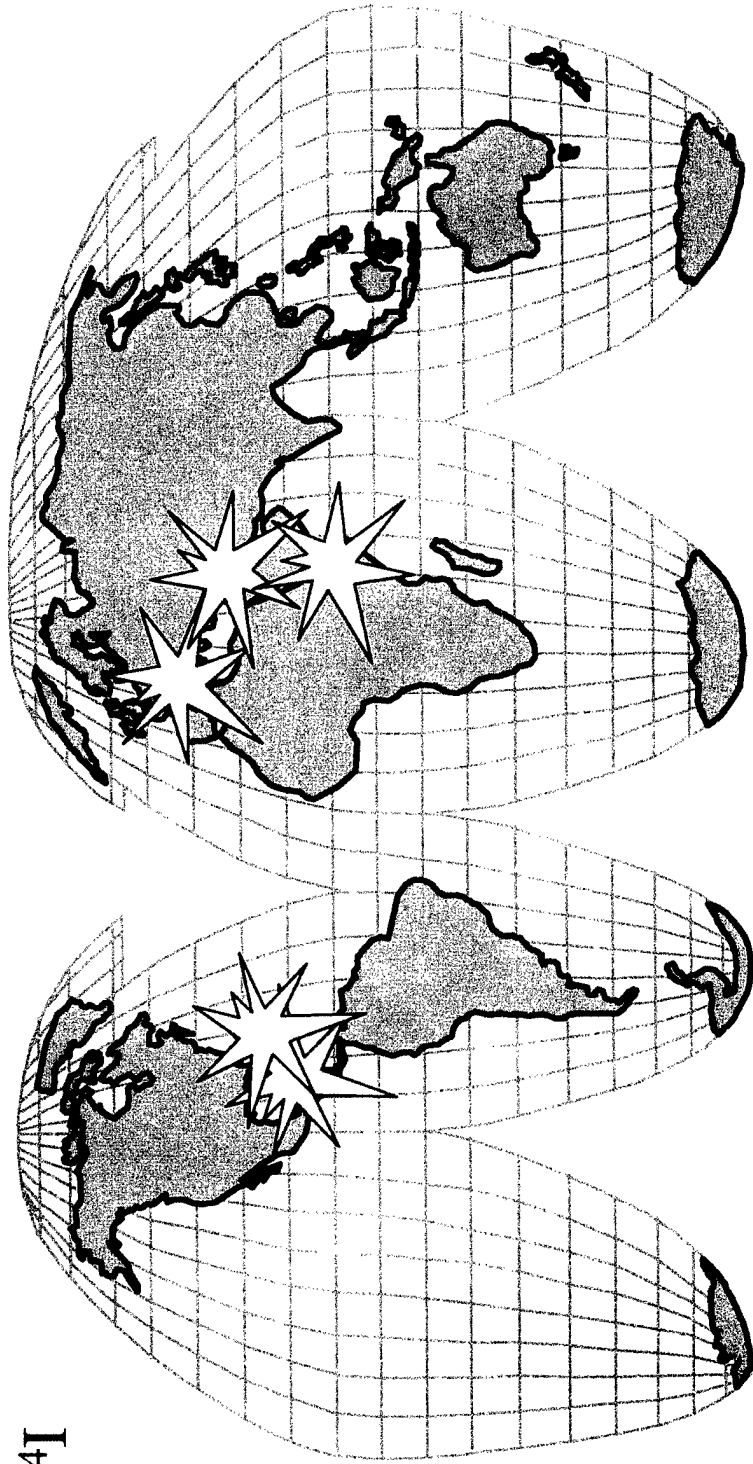
FIGURE 5 - RECRUITING BASE FOR NSAP S&T ADVISORS DURING 1996-1997

■ Partners in network of RDT&E activities linked  
by unique NSAP association



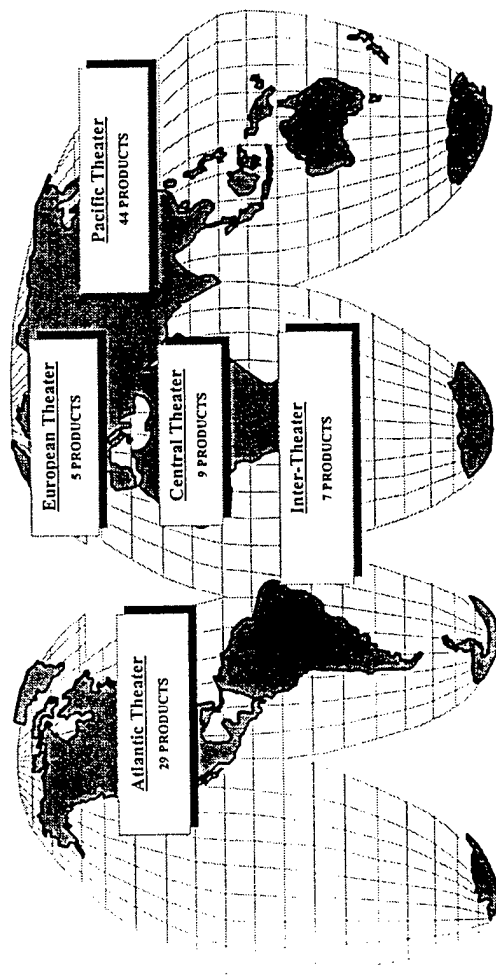
**FIGURE 6 - WORLDWIDE CRISES SUPPORTED BY NSAP DURING 1990-1996**

- Middle East: DESERT STORM/SHIELD, TBMD
- Somalia: Counter-targetting, non-lethals
- Carribean: Counter-drug
- Bosnia: Covert marking
- Haiti: C<sup>4</sup>I
- Etc.

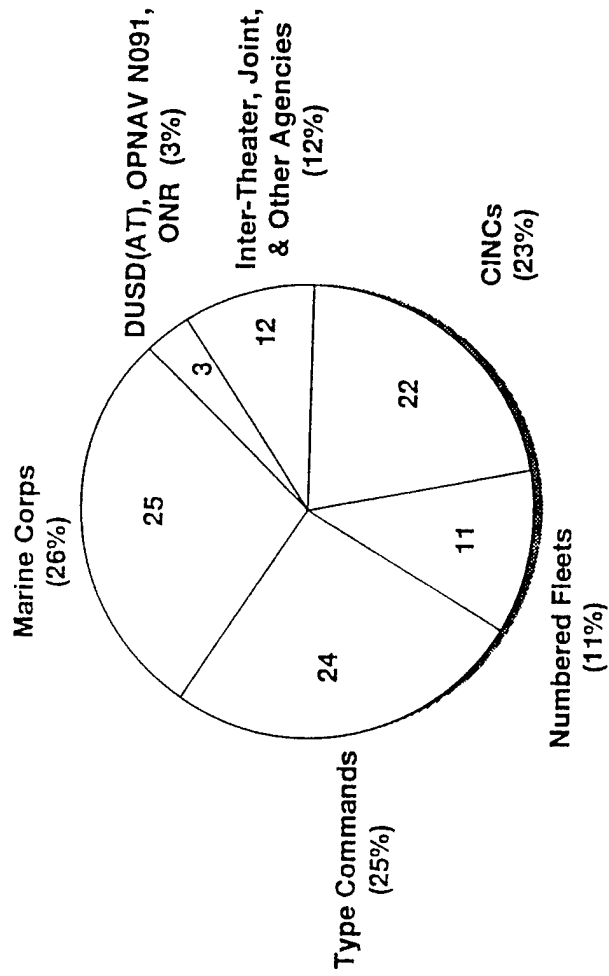




**FIGURE 7 - NSAP PRODUCTS, BY THEATER, DURING 1995-1997**



**FIGURE 8 - NSAP PRODUCTS, BY COMMAND TYPE, DURING 1995-1996**



**FIGURE 9 - NSAP PRODUCTS, BY NAVAL JMA/SA, DURING 1995-1996**

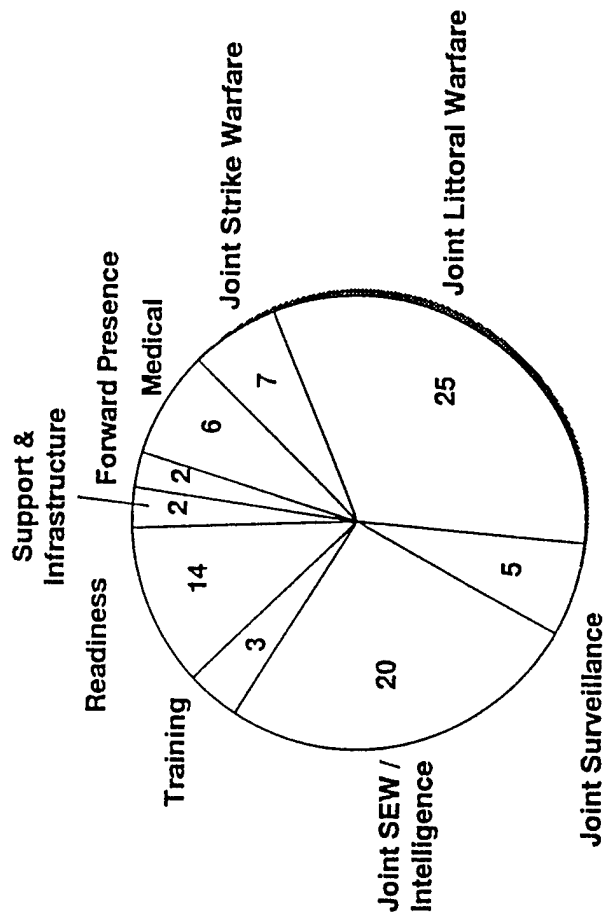


FIGURE 10 - MCM TUG USED DURING OPERATION EARNEST WILL (PERSIAN GULF 1987)

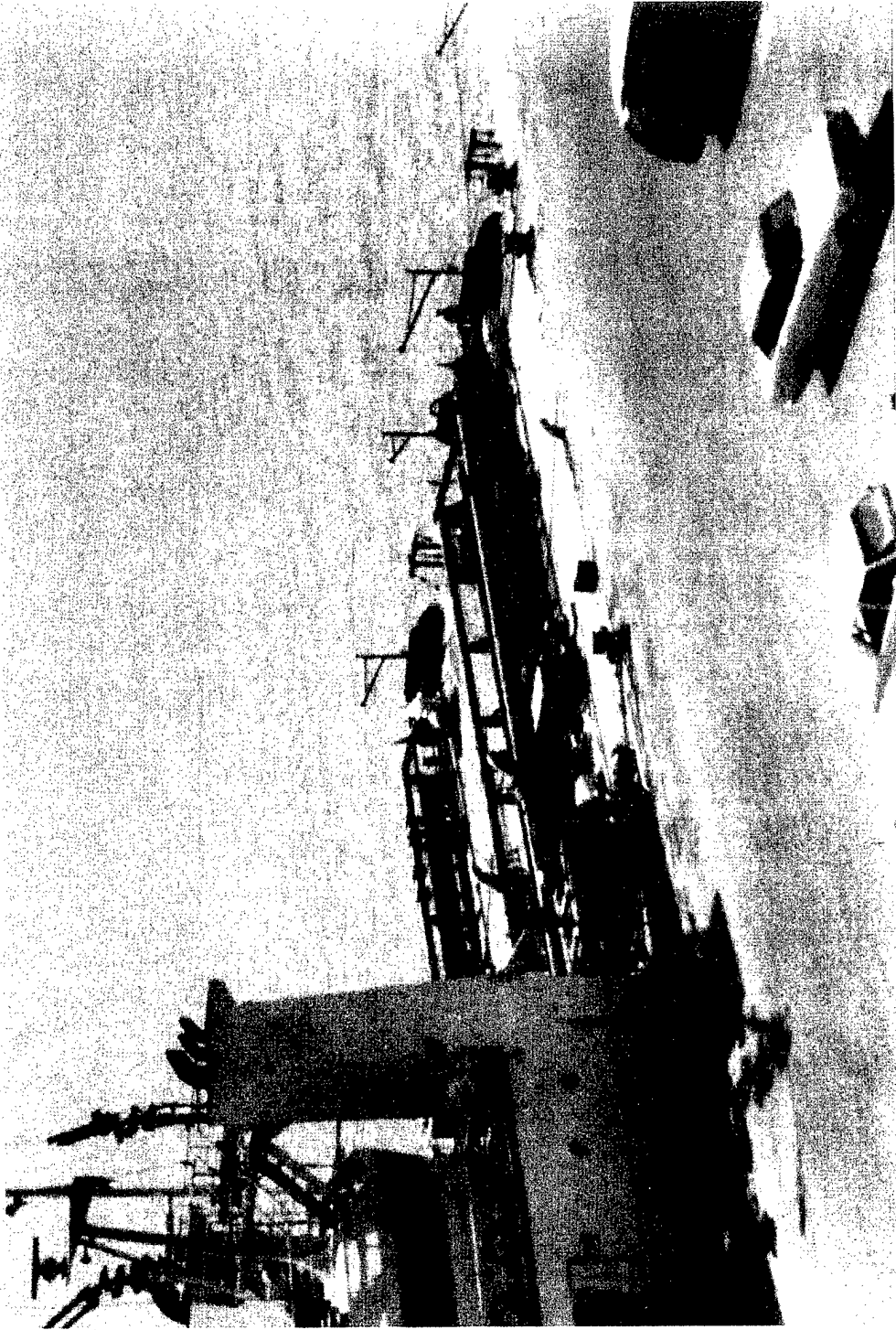
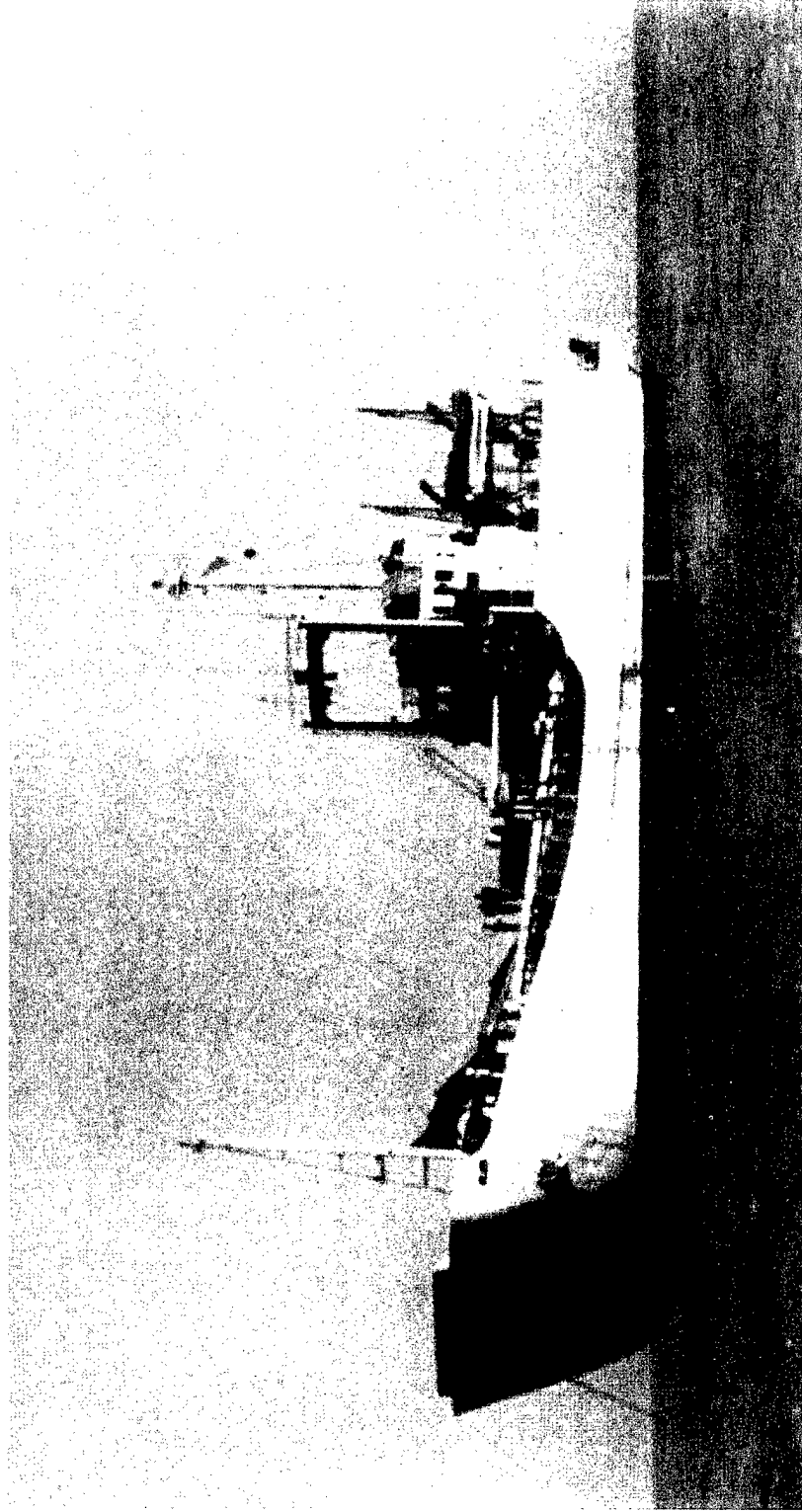


FIGURE 11 - CAPTURED MINELAYER IRAN AJR



*Iran Ajr*

FIGURE 12 - CAPTURED M08 MINES ABOARD IRAN AJR

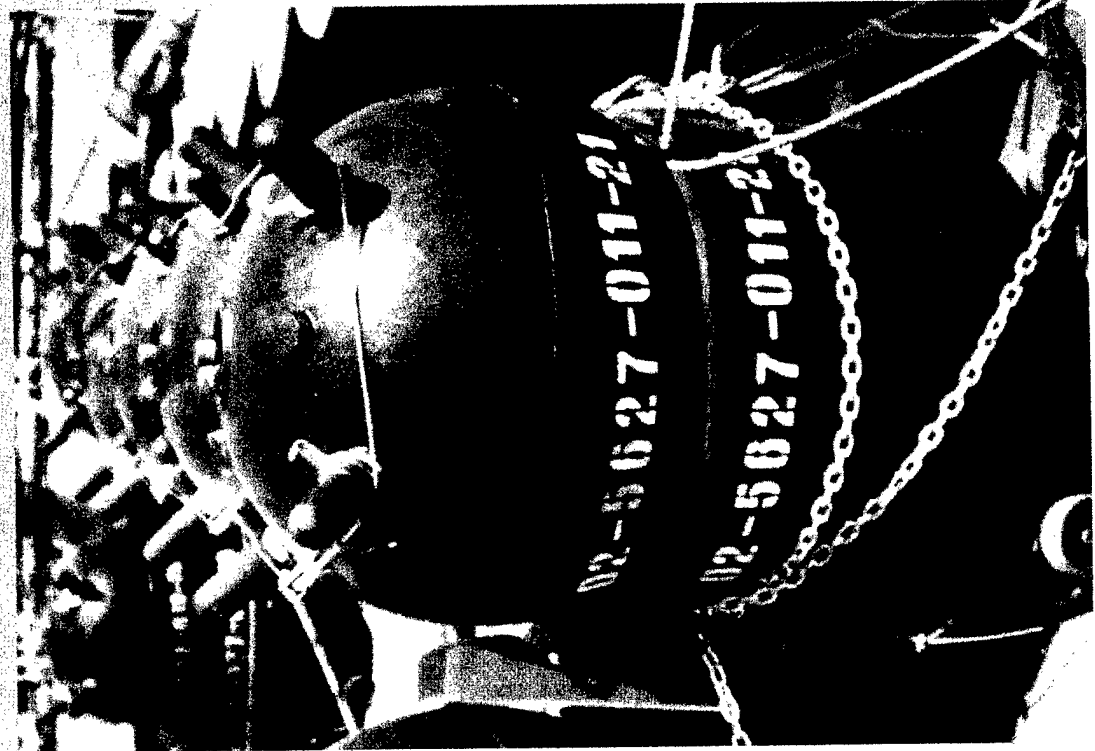
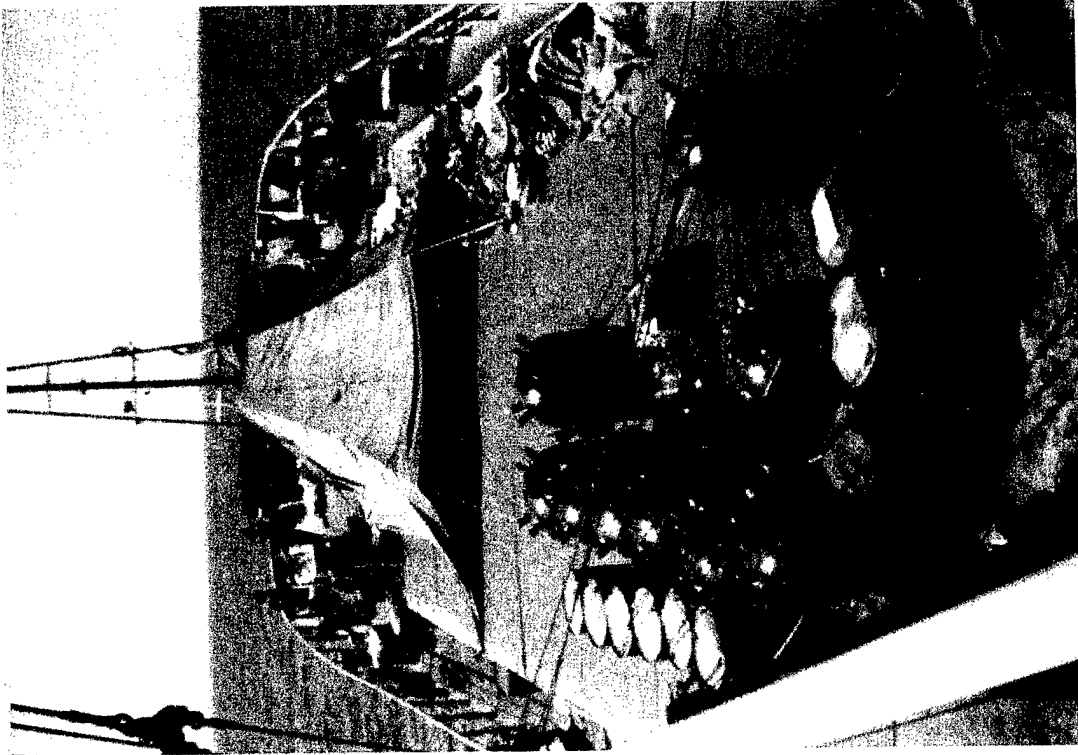


FIGURE 13 - MINE DEPLOYMENT DEVICE ABOARD IRAN AJR

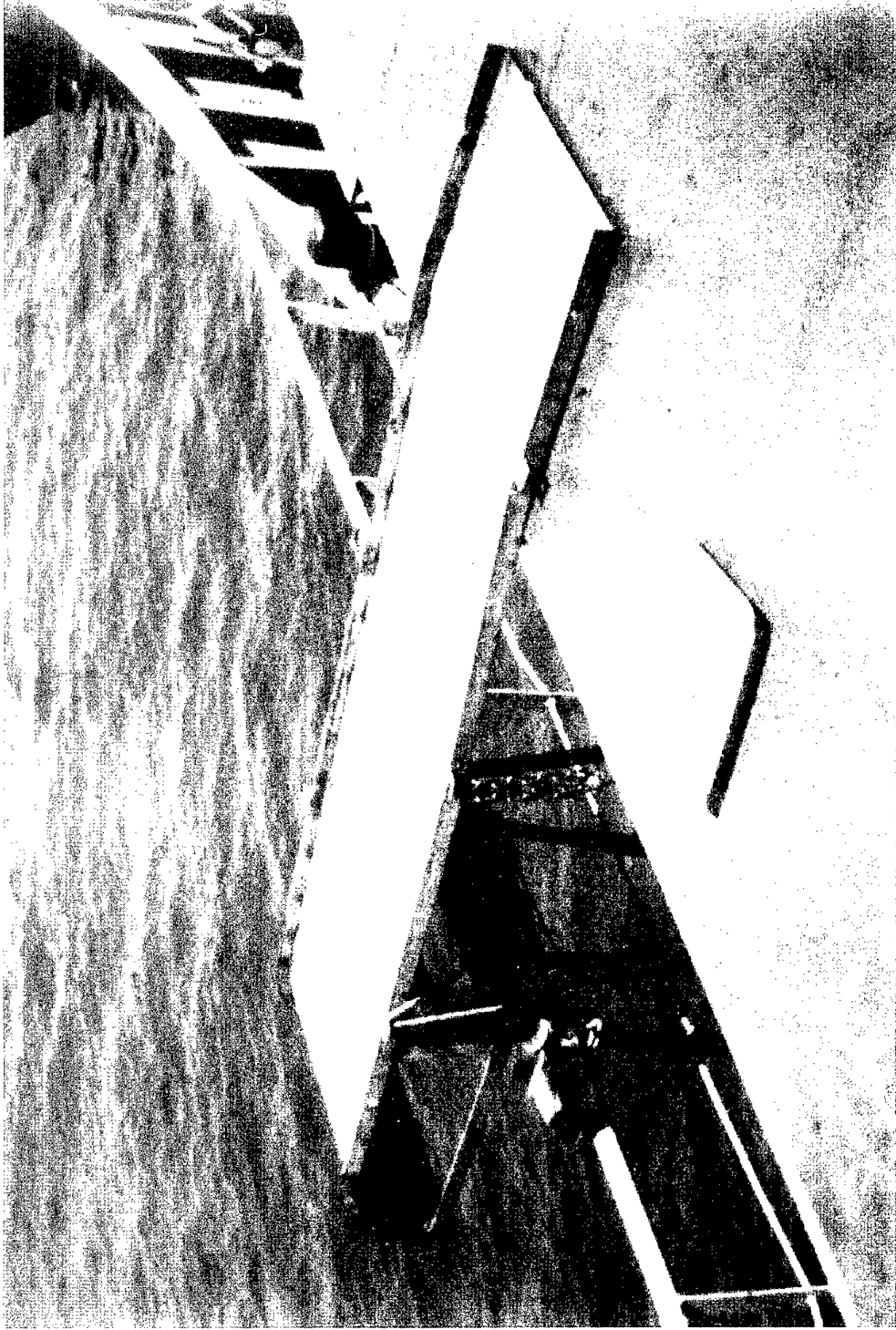
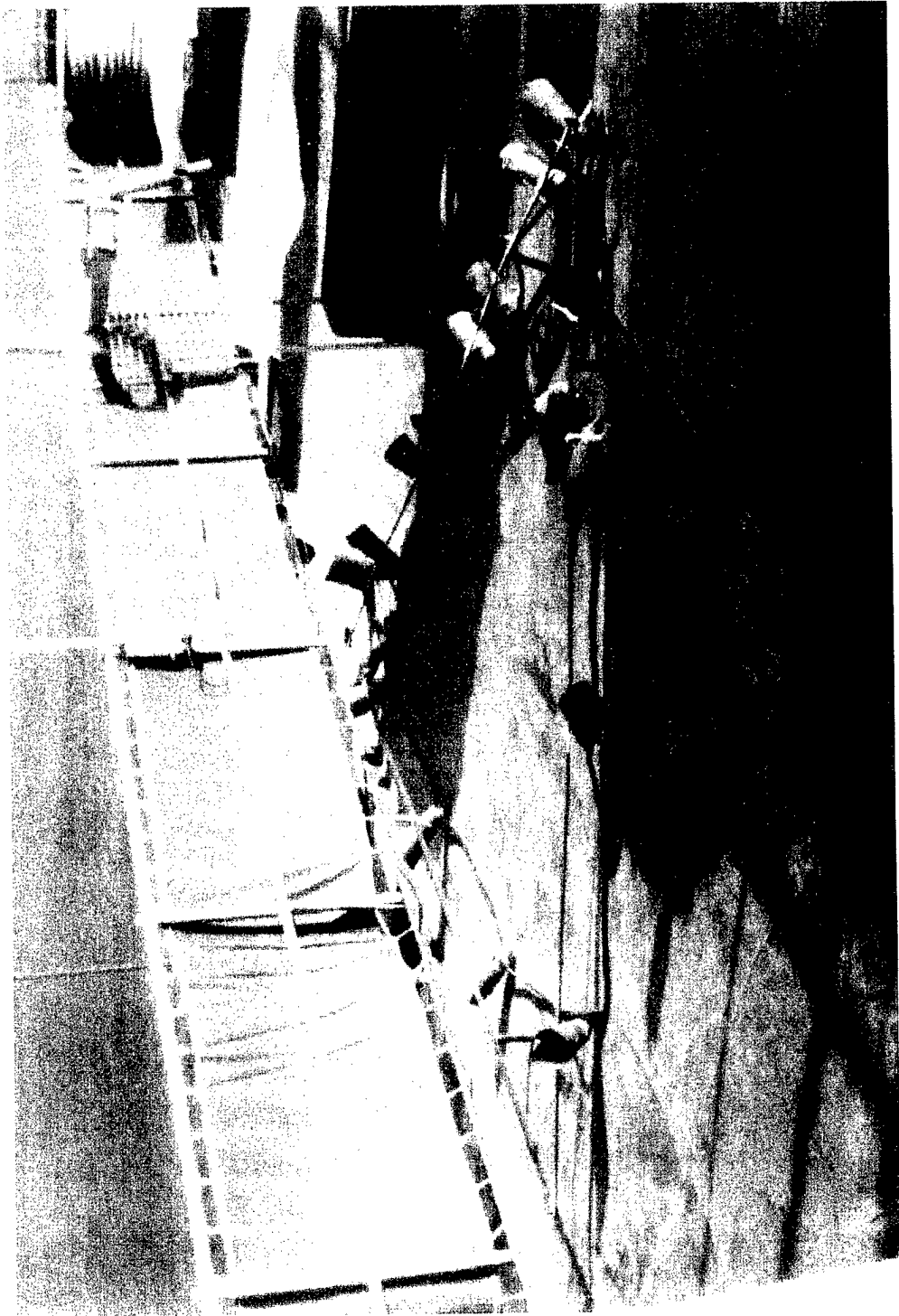


FIGURE 14 - U.S. TRIANGLE OF LIGHTS FOR NIGHT OPERATIONS

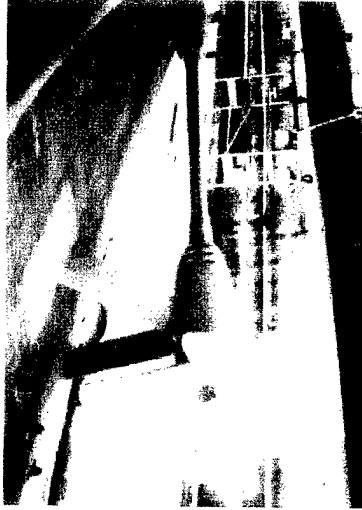




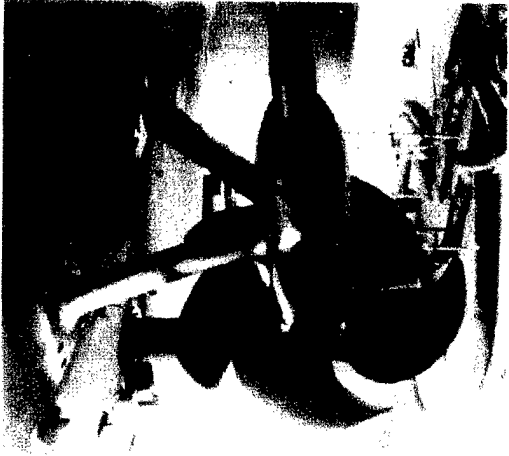
**FIGURE 15 - SIGNATURE REDUCTION OF MCM SHIPS DURING OPERATION DESERT SHIELD/STORM (1990-1991)**



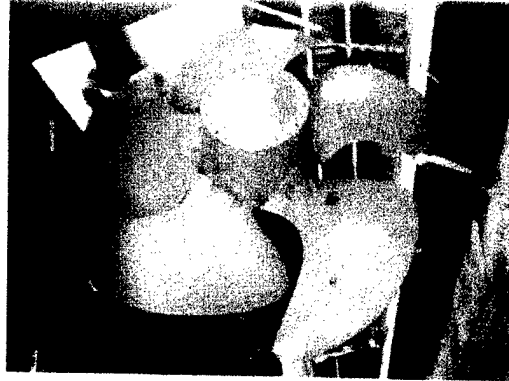
**PRIMER #150**



**MIDCOAT**



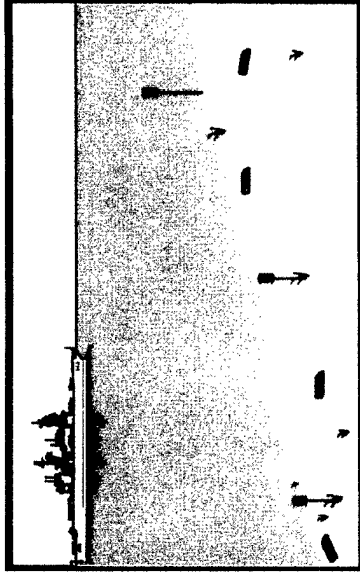
**TOPCOAT**



**VINYL ANTI-FOULING COAT**

**FIGURE 16 - NSAP TASK SAFE PASSAGE DURING OPERATION JOINT ENDEAVOR  
(ADRIATIC 1995-1996)**

- **Background:**
  - Amphibious Assault in Adriatic Sea (Yugoslavia)
  - ATF and CVBG Exposed to Mine Threat
    - Amphibious Assault Ships, Combatants, Support Ships
  - Foreign Influence Mines (Intelligence Estimates)
    - Magnetic / Acoustic, Passive / Passive Acoustic
- **Objective:**
  - Estimates of Mine Actuation and Damage Ranges
- **Payoff:**
  - Determine Water Depths where Ships are Threatened:  
Consequently,
  - Plan Operating Areas to Minimize Use of Threatened Waters
  - Plan MCM Operations for Threatened Areas



**FIGURE 17 - NSAP HELICOPTER VULNERABILITY TASK DURING OPERATION JOINT ENDEAVOR  
(ADRIATIC 1995-1996)**

**TABLE 1 - NSAP PRODUCT LINES**

- **Command Technology Issues (CTIs)**
- **Technical tasks**
- **Information, advice, & ideas**
- **Connectivity**
- **Partnerships**
- **“Blue Book”**
- **Crisis response**
- **S&T Investment influence**

TABLE 2 - SAMPLE NSAP TASKS DURING OPERATION END SWEEP (VIETNAM 1973)

- DST Simulator
- Mine Neutralization Study
- Helo Mine Detection
- Helo Navigation System
- Helo Hazards
- Magnetic Simulator
- Effectiveness Study

**TABLE 3 - SAMPLE NSAP TASKS DURING OPERATION NIMBUS STAR (SUEZ CANAL 1973-1974)**

- Swept Mine Locator
- NAVPLOT
- Ditch Clear
- Safe Tow II
- Mine Marker Launcher
- Improved Mechanical Sweep
- Inflight Refueling

**TABLE 4 - HISTORICAL REFERENCES TO NSAP MINE WARFARE SUPPORT**

1. Operation "End Sweep" - A History of Mine Sweeping Operations in North Vietnam (8 May 1972 - 28 July 1973)  
Tensor Industries, Inc., September 1977
2. Operation End Sweep  
Center for Naval Analyses (CAN-CRC-277), February 1975
3. Suez Canal Clearance Operation - Task Force 65 - Final Report  
Naval Inshore Warfare Command Atlantic, May 1995
4. Operation Analysis During the 1974 Search for Unexplored Ordnance in the Suez Canal  
Wagner (Daniel, H.), Assoc., June 1975
5. AN/UQS-1 Mine Hunting Sonar, Operational Evaluation  
Naval Forces, Vietnam (NAVFORV-MISC Report), April 1969
6. Operational Handbook for Swimmer Defense  
Naval Forces, Vietnam (NAVFORV-MISC Report), April 1969
7. Swimmer Defense Handbook  
Naval Coastal Systems Lab, March 1973
8. United States Navy in "Desert Shield", "Desert Storm"  
Office of the Chief of Naval Operations, May 1991







# MINE COUNTERMEASURES EXERCISE ANALYSIS

## A HISTORICAL REVIEW

George W. Pollitt  
Mine Warfare Command  
325 Fifth St., SE  
Corpus Christi, TX 78419

### ABSTRACT

During the 1980s Mine Countermeasures (MCM) exercises emphasized the clearance of Continental United States (CONUS) ports to enable the resupply of Europe. Three to four exercises were analyzed each year to measure the tactical parameters used in the planning and evaluation process. At the end of the Cold War emphasis shifted to littoral warfare, which required a much faster reaction to changing circumstances.

### INTRODUCTION

This paper reviews MCM exercise analysis conducted by the staff of Commander, Mine Warfare Command (COMINEWARCOM) since the early 1980s.

### EXERCISE ANALYSIS IN THE 1970s

In the late 1970s, COMINEWARCOM was a field activity of the CNO. The commanders of various MCM forces reported through different chains of command. Exercise analyses, when performed, were directed by the MCM Commander and were usually prepared after the exercise by his operations staff. MCM exercise reports of the late 1970s and early

1980s were generally of two types: one type said "look how great we did;" the other type said, "we can't do the job without precise navigation, neutralization systems, buried mine detection, etc.," or whatever perceived deficiency the Commander wanted to document. No standardized format was followed, and there was little analysis of baseline capabilities.

### EXERCISE ANALYSIS IN THE 1980s

COMINEWARCOM was responsible for analyzing Mine Warfare exercises, but without ownership of the forces, the staff did not always have access to the data it needed to perform detailed and objective analyses. In early 1981 COMINEWARCOM drafted a charter which established an MCM Exercise Analysis Section (MEAS) and its functions and specified which exercises the Command intended to analyze for FY81 and FY82. The Fleet Commanders in Chief endorsed the charter and a formal program of exercise analysis began. The MEAS was comprised of three officers representing Surface MCM (SMCM), Airborne MCM (AMCM), and Explosive Ordnance Disposal (EOD) diver MCM. The MCM Analyst worked part time on exercise analysis, and there was occasional support from contractors or the

Coastal Systems Station in Panama City, FL. To do the lengthy evaluation computations, COMINEWARCOM developed, with help from contractors and the laboratory in Panama City, an automated routine called the MCM Commander's Tactical Decision Aid (MCM-CTDA).

### **MCM COMMANDER'S TACTICAL DECISION AID**

The MCM-CTDA calculated estimated percent clearances against different mine types in different parts of the clearance area based on the amount of hunting and sweeping applied and on planning estimates of each system's effectiveness. This type of calculation is called "MCM Evaluation" as opposed to "analysis" which comes after the exercise or operation is complete. The advantage to the analyst of evaluating ongoing exercises was that the process collected the operational data in the computer that would be needed for later exercise analysis. The benefit to the MCM Commander was that he received a daily status of his clearance operation which facilitated tasking decisions. One MCM Commander called the daily evaluation results his "cheat sheet" because it made his job so much easier. Thus the analyst provided a useful service and was not just an observer or critic. Incidentally, the MCM-CTDA was designed to accept hunting data, influence sweeping data, and mechanical sweeping data which the program combined into estimated percent clearances. It could account for delay arming and ship counts. As the model evolved, routines were added to keep track of known mine positions, i.e., "mine totes," and to estimate the residual threat to transitors based on percent clearance applied and number of mines cleared. The estimated threat is the information which the MCM Commander's

boss is most interested in. The biggest disadvantage of the MCM-CTDA was that it was not programmed in a modern computer environment, and the data was tedious to enter. For these reasons, the MCM-CTDA never became a mainstream aid operated by MCM planners.

### **POST-EXERCISE ANALYSES**

At the end of the tactical phase of each exercise, data was available in the computer to perform a Quicklook analysis. Emphasis was placed on calculating the tactical parameters which would be needed for future planning. Parameters routinely calculated included the achieved Characteristic Search Probabilities for minehunting and Usage Factors for different platforms and systems. There was almost no historic database for these parameters in the early 1980s. They were important not only for MCM planning purposes but also for analyzing force level requirements. In the beginning, estimates of the tactical parameters used for evaluation were optimistic so, as might be expected, the MCM-CTDA overestimated actual percent clearances. These entering arguments were adjusted based on prior exercise results, so the evaluation estimates got better and better as time went on. This feedback of analysis results into the planning and evaluation process provided calibration for the MCM-CTDA routines.

### **EXERCISES ANALYZED**

The MEAS analyzed 3 to 4 exercises every year between 1981 and 1987. In 1987 the exercise cycle was broken by the start of the Tanker War, as MCM men and equipment were sent to the Persian Gulf. During the summer of 1988, OPNAV established Project Tasking Kingfisher which

tested the effectiveness of existing equipment in Panama City and in the Persian Gulf. Members of COMINEWARCOM and OPTEVFOR staffs formed the Ashore Tactical Evaluation Detachment (ATED) which analyzed selected systems in the Persian Gulf, including a modified Anti-Submarine Warfare (ASW) sonar which could detect mine sized objects. This modification became known as the Kingfisher Mod. In the summer of 1991, a team of analysts from COMINEWARCOM and the Coastal Systems Station went to the Persian Gulf and evaluated the DESERT STORM clean up operation for COMUSNAVCENT. The MCM-CTDA was the tool used for the calculations.

### **MCM EXERCISE AND OPERATIONAL ANALYSIS**

The table below summarizes the analyses performed in the 1980s by the COMINEWARCOM MEAS.

### **APPLICATIONS OF ANALYSIS RESULTS**

The exercise analyses shown in the table were tied to MCM tactical development. Values of achieved Characteristic Search Probabilities were used to update tables in the Naval Warfare Publications (NWP) and to calibrate the MCM planning and evaluation models. An annual MCM Operations Tactics Group (MCM OTG) was formed to guide the process of feeding exercise lessons learned into existing and developmental tactics. Emphasis at that time was to develop MCM tactics that integrated the use of surface MCM, AMCM, EOD, MCM Craft of Opportunity (COOP) and other MCM assets. Among the tactics developed through the MCM OTG process and validated through exercise analysis were:

Integrated MCM Task Force Tactics; MCM Port Breakout Tactics; MCM Tactics in Amphibious Operations; MCM Communication, Command and Control; and MCM Navigation Tactics.

### **THE WAY AHEAD**

At the end of the Cold War, emphasis shifted away from CONUS port breakout toward littoral warfare, which required faster reaction to changing circumstances. To facilitate fast reaction, work was initiated to develop a modern Command, Control, Communications, Computers and Intelligence (C4I) system. The computational part of the new C4I is the MIW Environmental Decision Aid Library (MEDAL), which is JMCIS compatible. A Mine Warfare Readiness and Effectiveness Measuring (MIREM) program has been initiated to analyze Mine Warfare exercises in the same way that SHAREM analyzes ASW exercises.

# MCM EXERCISE AND OPERATIONAL ANALYSIS

### LEGEND

- EOD MCM DET
- MMS
- APSS
- AMCM HUNT
- MSO HUNT
- 6. MSB HUNT
- 7. COOP
- 8. AMCM SWEEP
- 9. MSO SWEEP
- 0. MSB SWEEP

### TYPE OPERATION OPERATIONAL EVALUATIONS POST EXERCISE ANALYSES LESSONS LEARNED

MEAS	NAME OF ANALYSIS	LOCATION	PORT BREAKOUT	CHOKEPPOINT	AMPHIBIOUS	ROUTE SURVEY	OTHER	CLEARANCE EVAL	MINE/MILC TOTE	THREAT CALCULATION	TRACK RECONSTRUCTION	DAMAGE ASSESSMENT	MINEHUNTING ANALYSIS	MINESWEEPING ANALYSIS	USAGE FACTOR	FALSE ALARM DENSITY	LOCALIZATION PROB	PROSECUTION OF MILCS	NAVIGATION	COMMAND & CONTROL	COMMUNICATIONS	NEUTRALIZATION	ENVIRONMENT	NIIM	LEADOUT	MCM PLANNING	MET LAY AND RECOVERY	
MEES-1	ISE ROEBUCK	FIRTH OF FORTH	x					x							8,9,0													
MEES-2	RCISE COMORAN 81	BAY OF CADIZ, SPAIN	x												8,9,0													
MEES-3	EX 03-81	HOOD CANAL, WASH	x			x		x							9													
MEES-4	ON OCEAN SAFARI 81	LISBON, PORTUGAL	x					x							8,0													
MEES-5	ON OCEAN SAFARI 82	KING'S BAY/MAYPORT	x					x							2,8,0													
MEES-6	EL USHER 82-2	SAN DIEGO	x			x		x							2,5													
MEES-7	EL USHER 82-2	CAMP PENDLETON	x					x							3,5,8,9													
MEES-8	ON OCEAN SAFARI 82	OCEANSIDE HARBOR, CA	x					x							2,6													
MEAS-9	ON OCEAN SAFARI 83	MOREHEAD CITY, NC	x					x							2,6,8,9,0													
MEAS-10	ON OCEAN SAFARI 83 AOA	ONSHLOW BEACH, NC	x					x																				
MEAS-11	ON OCEAN SAFARI 83-5	SAN DIEGO	x			x		x																				
MEAS-12	DEX 2-83	NORFOLK/CHASN/MAYPORT	x			x		x																				
MEAS-13	ED EFFORT 84	MOREHEAD CITY, NC	x					x																				
MEAS-14	AN VENTURE 84	NORFOLK	x					x							8,9													
MEAS-15	AN VENTURE/RIMPAC 84	VIEQUES/PEARL HARBOR	x			x																						
MEAS-16	PAC 84	PEARL HARBOR	x												3													
MEAS-17	NEL USHER 85-2	S. DIEGOL. BEACH/CORONADO	x			x		x							2,4,5													
MEAS-18	ID SHIELD 85	MOREHEAD CITY, NC	x					x							2,5													
MEAS-19	SCOT 2-85	STRAIT OF JUAN DE FUCA	x			x		x							5,7													
MEAS-20	STEX 2-86	NORFOLK	x												9													
MEAS-21	REX 1-86	KING'S BAY, GA	x			x		x							4,5,6,7													
MEAS-22	NEL BLITZ 86-1	CAMP PENDLETON	x					x							4,5													
MEAS-24	GLAVESTON 1-87	GALVESTON, TX	x					x							4,5													
MEAS-25	ARDEZXPAC 87	SAN DIEGO, LONG BEACH	x					x							5													
MEAS-26	TCOOPEX 1-89	PORT CANAVERAL, FL	x					x							5													
CMWC 1	ON OCEAN SAFARI 85	BOSTON, MA	x												4													
CMWC 1	ON OCEAN SAFARI 85	GLUF OF SUEZ, EGYPT													4													
LOOK	ON OPERATION INTENSE																											
CANUS	TOT 2-81	HALIFAX, NOVA SCOTIA	x					x							8,9													
OCEAN	U 81, NADREX LEVEL II	LISBON, PORTUGAL	x																									

15 November 1996

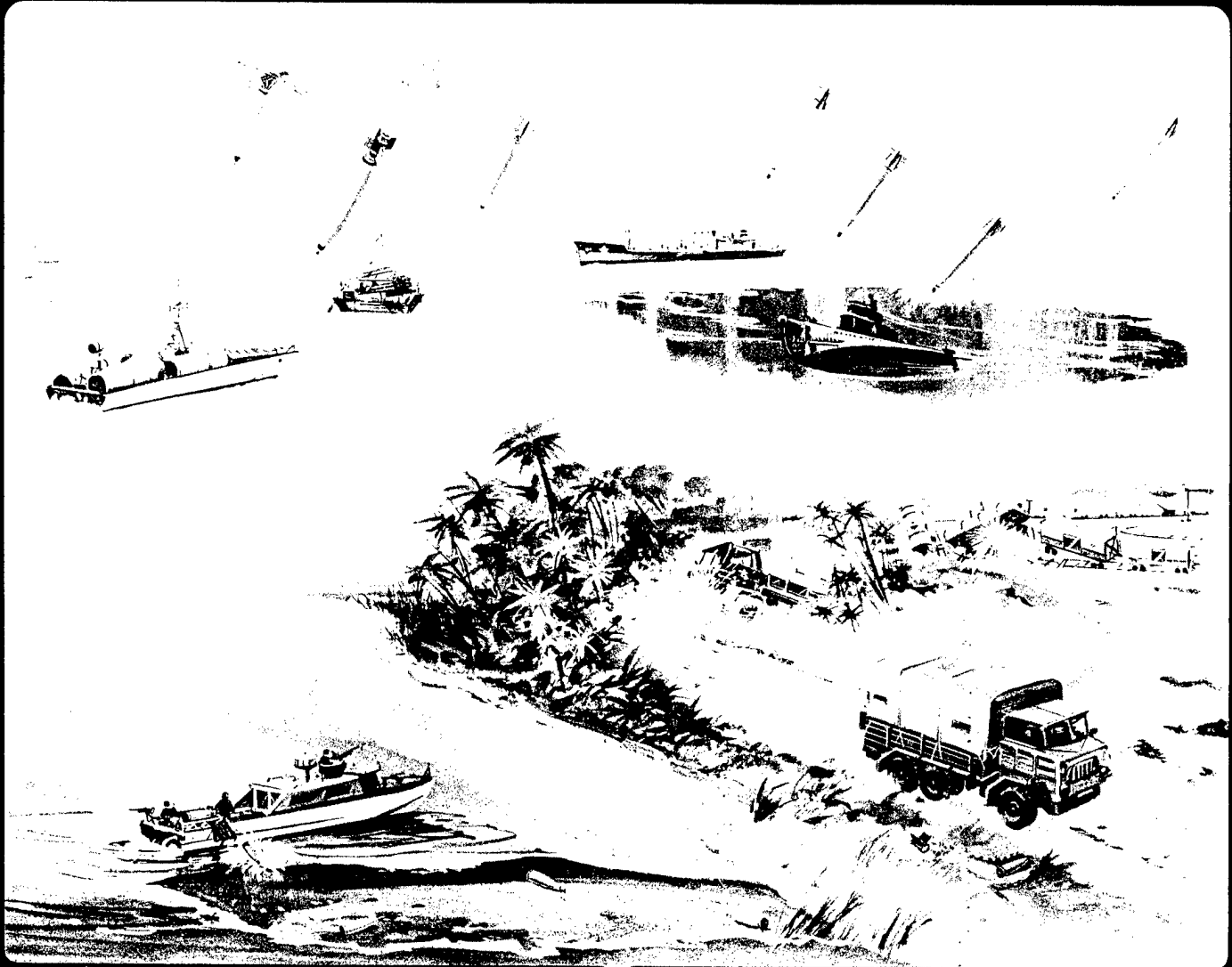
**BIOGRAPHY**  
**GEORGE W. POLLITT**

Mr. Pollitt is a 1963 graduate of the U.S. Air Force Academy. After serving six years as an Air Force navigator on KC-135 tanker aircraft, he left the service and returned to school, earning an ME degree in Aerospace Engineering from the University of Florida. From 1971 to 1975, Mr. Pollitt worked for the Naval Ship Engineering Center as a Mechanical Engineer; his primary duties were as Technical Agent for the Mine Neutralization System and the Shipborne Minehunting Sonar. From 1975 to 1980, he worked at the Naval Coastal Systems Center in Panama City as an Operations Research Analyst. His main duties included tactics development, tactical analysis, and force level studies for Mine Warfare systems. Since June 1980, he has worked at Commander, Mine Warfare Command as Mine Countermeasures Analyst, Advisor for Research and Analysis, Deputy Department Head for Operations, Department Head for Requirements, and his current position as Technical Director. He lives with his wife Beverly in Corpus Christi, TX and has three daughters: Phyllis, Harriet, and Rebecca.



# DEVELOPMENT HISTORY OF

## THE FAMILY OF



# DESTROYERS



ABSTRACT

Mines are effective and economical weapons. This has been demonstrated in the Vietnam conflict. The use of the Destructor (DST) weapons in this extensive mining campaign is now being recognized as a major factor in the termination of this conflict.

The DST Mk 36 has been deployed in large quantities by the Navy, Air Force, and Marines.

The DST is an aerial bomb that has been converted into a mine. Developed by the Naval Ordnance Laboratory, White Oak, the DST concept employs the components and tools of the Modification Kit Mk 75 to convert any of the Navy's Mk 80 series bombs and the USAF bomb M117 into a mine.

The DST is a magnetic or mag/seismic influence mine. Typically employed from aircraft in either the free-fall or retarded modes--along roads, trails, waterways or in harbors--the DST lies concealed as a land or naval mine to await the approach of a suitable target. Land targets range from trucks to trains; water targets from sampans to freighters.

The Modification Kit Mk 75 costs \$350. It can be assembled in less than 15 minutes and can be handled like standard weapon components. DST requires no field testing, no special training or tactics, and no modification to the aircraft.

The DST provides a highly versatile, cost effective threat which extends the use of existing weapons and delivery systems. Over 1/3 million have been produced.

Charles A. Rowzee  
Naval Ordnance Laboratory  
White Oak, Maryland  
June 1973

## CONCEPT

Naval mining has always proved to be an effective weapon--but why then is it not attractive to the Fleet? In an attempt to stimulate interest in naval mining the concept of a bomb-mine originated. It was 1959 when an excess of 250# GP bombs became apparent and concern as to what could be done with this excess was being considered. Why not a bomb-mine? A bomb that can be converted to a mine. If mines could be treated as bombs, they might become more attractive to the Fleet. This was the origin of the bomb-mine concept. Subsequently, several engineering models were fabricated and tested.

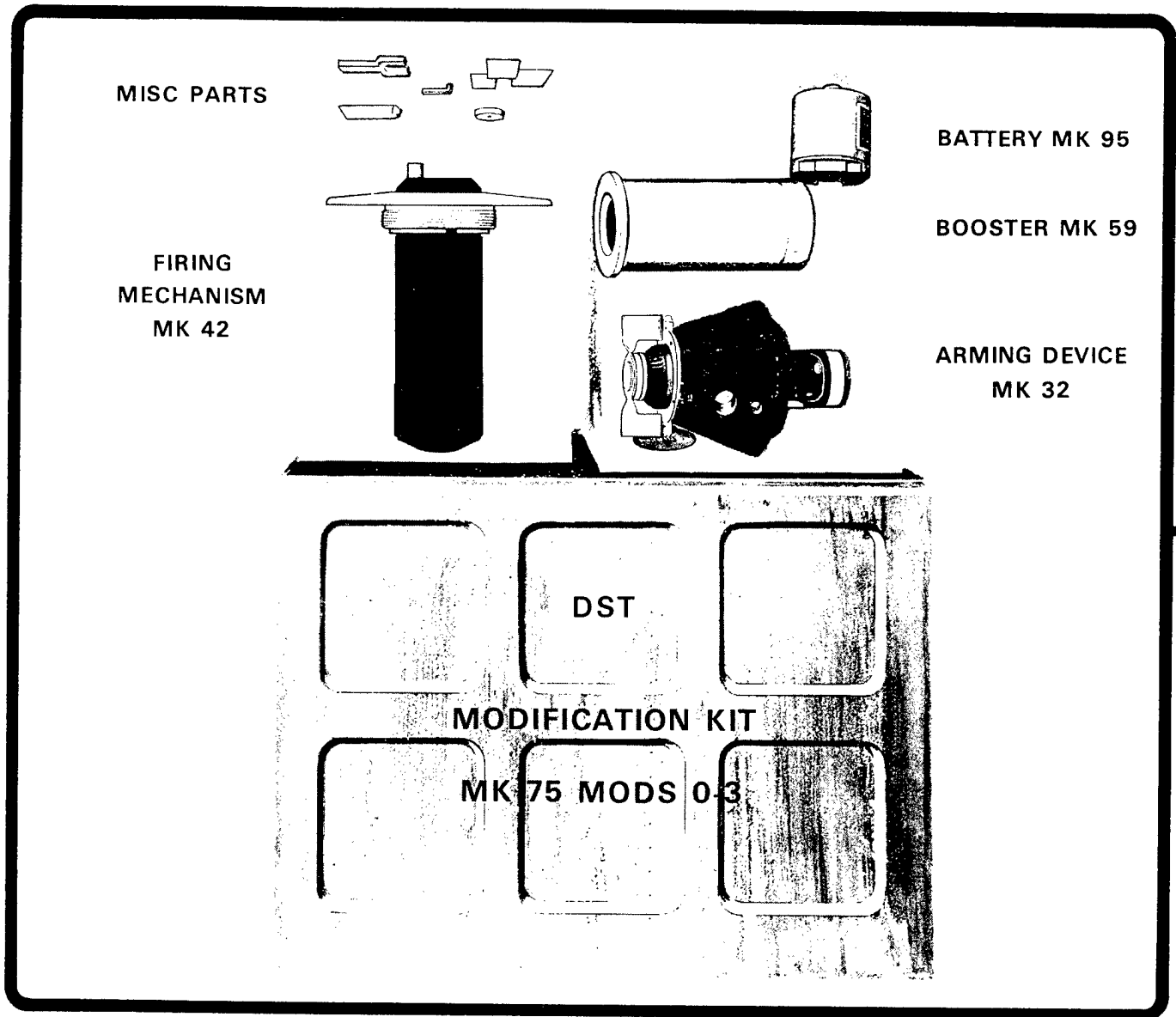
Concern at NOL and elsewhere for possible deficiencies in the Navy's arsenal of weapons for conducting limited war led in 1960 to a systematic study by the "Limited War Study Committee," whose objective was to determine the types, characteristics, and feasibility of weapons required to prosecute future limited wars.

As a result of this committee study, a feasibility study of small, anti-amphibious mines to be coupled with a fast mine-laying technique was initiated. An NOL study group was established to form the "Survey Committee." In 1962 the findings of this committee were reported in NOLTR 62-71 which, among other proposals, recommended the "Anti-Invasion Mine" (bomb-mine concept).

## EARLY DEVELOPMENT

At the 6th Mine Conference Meeting (1962) a bomb-mine concept was proposed using old GP bombs with short search coil. This concept attracted little attention. In 1964 NOL initiated the thin film sensor development with the Burroughs Corporation to provide an alternate sensor for the search coil. By 1966 this sensor looked promising for naval mines. When NOL was asked what could be done to interdict the inland waterways of SEA, among other suggestions, the bomb-mine concept was recommended. In August of 1966 this concept was adopted and development of a kit to convert the now stockpiled Mk 82 bombs into mines (since no GP bombs were left) was initiated by NOSC.

This kit was the Mk 75 Modification Kit which contained all the components necessary to convert a conventional bomb into an underwater mine or land mine. The converted bomb-to-mine weapon was called the Destructor--by definition a cylindrical metallic item containing explosives. In name this weapon was neither a bomb nor a mine, and provided interesting alternatives, on paper at least, whenever there was a bombing or mining halt.



Within six months a weapon system was available for Fleet operational evaluation. By June 1967--10 months later--the DST Mk 36 was deployed and has been used continuously ever since. Over a 1/4 million DST's have been deployed in waterways and on roads without a safety incident. This large-scale usage shows the attractiveness to the Services of this weapon system.

No major problems or delays occurred in the entire program. This may have been due in part to the frequent visits by the weapon technical experts in areas where difficulty might be experienced. For the initial assembly and deployment of the DST weapon, an NOL expert over-saw the entire operation. In the depot test area at Subic an NOL expert assisted in the early stages of mechanism testing to insure that this operation continued without interruption. On two occasions problems occurred which could have been disastrous, but fortunately a rapid solution was achieved which eliminated a crisis. The first incident occurred during the fabrication of firing mechanisms for Laboratory and Fleet evaluation. The firing mechanisms passed all tests and the final step of potting was completed. All mechanisms failed after potting. Hindsight showed that excessive heat generated during curing cycle damaged the electronics. Since this was a six-month development plan it appeared that the program would be canceled. The design had proven satisfactory so Burrough's, by some magic, was able to procure sufficient components to meet the scheduled delivery. This time the potting material was replaced by the glass beads. The second incident occurred after some 100K Mk 42 Mechanisms had been manufactured. The Mk 24 electro-chemical timer developed intermittent operation. Investigation revealed a chemical reaction between solution and gasket to be the cause. Since undesired elements in chemical solution and/or gasket material could not be specified, the E-cell timer was introduced into the design. To prevent a production delay, the Mk 24 electro-chemical timers were paralleled which demonstrated a reliability of 99%. The new E-cell design followed shortly without any delay to the Fleet requirements.

Here is a new concept for a relatively major weapon--the bomb-mine concept provides a means to achieve a reliable low-cost large-scale usage weapon. There is, however, a wide-spread belief that the DST weapon, while fulfilling an urgent need, was nevertheless an interim "quick and dirty" stop-gap approach. To those familiar with this weapon and mining in general, this is an erroneous belief, for the DST has proven itself as a most reliable, cost effective, and as safe a mine system ever developed. Not widely known is that the development of the original "bomb-mine" and the follow-on DST weapon both followed the same specific approach. The approach taken was straight forward: This weapon development approach, together with specific examples of how implemented, should illustrate how development costs and time can be significantly reduced while still providing dependable ordnance.

#### REALISTIC REQUIREMENTS WERE ESTABLISHED:

The customary mine operating life from 1 to 2 years was relaxed to 4 - 6 months, which has since proven adequate. Weapon on-deck assembly did not meet HERO safety requirements. While safety requirements were not relaxed, the problem was resolved by assembling the weapon below deck where electromagnetic radiation was reduced to a safe level. No countermeasure protection was required for the initial mod even though some existed. Increased protection was gradually provided in subsequent mods.

INTERCHANGEABLE WITH ATTACK ORDNANCE WAS MAINTAINED:

For the weapon the Mk 80 Series Bomb was used without case modifications so that stores could be used by merely supplying an adaption kit.

EXISTING PROVEN DESIGNS WERE USED BASICALLY:

The safety and arming was provided by modifying the Army's M904 impact fuse.

The explosive link between detonator and main charge was provided by an Air Force booster.

The influence detector, while not yet in production, was provided by a simple rugged thin-film magnetic sensor developed by the Burroughs Corporation under an earlier NOL-IED exploratory development task.

LOGISTIC SIMPLICITY WAS ACHIEVED:

This weapon is logistically simple. It is handled much like a bomb. It requires no special training or personnel and little or no testing. Weapon assembly <15 minutes. Also, since it makes use of on-board ordnance, it does not require extensive carrier storage space.

LOW COST WAS ACHIEVED:

Use of proven designs in production brought kit cost to under \$350, and greatly increased the chances for a successful and useful development. Program pace was maintained at "fire-drill" level, i.e., top-priority, quick-reaction, SEA-response type. This has been demonstrated as an efficient development approach as it forces effort to be concentrated on major considerations. Things such as delay arming settings, number of options, and countermeasure resistance can be discussed at great length without achieving significant results.

EFFECTIVE COOPERATION BETWEEN ACTIVITIES WAS ACHIEVED:

A factor that is most important in a rapid successful development is cooperation between involved activities. Without superb assistance from CNO, NAVORDSYSCOM, the manufacturer and NOL participants, this could have resulted in another weapon development progressing too slow to be useful. In the DST development the original specifications were unaltered. Changes in specifications were brought in only as additional mods of the weapon. This weapon development approach was adhered to in changing from the bomb-mine design of 1960 to the current DST weapon utilizing bomb ordnance.

ORIGINAL SPECIFICATIONS FOR DESTROYER MK 36 (1966)

Envelope	Mk 82 Bomb Case with Bomb Fin Mk 15 Mod 1 (Snakeye Tail)
Explosive Train	Modified M904 Fuze for Electric Firing with ML34 Booster Adapter
Firing Device	Magnetic, Two-Look; Thin-Film Sensor; Fixed Sensitivity
Delayed Arming	Mk 24 Interval Timer; Fixed Delay
Ship Counter	None
Self Destruct	Yes; weapon detonates when power supply runs down
Sterilization	None
Anti-Recovery	Yes; weapon will detonate after arming delay if moved or disassembly is attempted
Countermeasures	Resistant to explosive countermeasures
Armed Life	Three months minimum
Charge	190 lbs H-6
Primary Target	Indigenous small craft with an engine or carrying ferrous cargo
Planting Depth	2 to 40 feet of water, including burial in mud or sand
Planting Mode	All fixed-wing USN, USAF and USMC aircraft capable of carriage and release of comparable GP low-drag bombs
Aircraft Compatibility	Same capability as with comparable GP low-drag bombs. Employ existing bomb-handling equipment and procedures
Ballistic Parameters	Identical to comparable GP low-drag bomb with snakeye tail
Packaging	Employ Adaption Kit concept (necessary components and parts to convert Mk 82 case to DST Mk 36)

Storage Life	Will withstand unprotected storage fully assembled for a maximum of 3 days (storage at temperature of 85°F for 3 months will reduce operational life by 20%)
Safety	Will be safe to assemble, test, handle and store. Will not be vulnerable to HERO
Reliability	80% immediately after planting
Maintainability	Will approach fixed ammunition; may be stockpiled for several years with minimum maintenance
Assembly and Test	Assembly and test time will not exceed 3 hours; test equipment will be of GO NO-GO type; work suitable for minemen or aviation ordnancemen
Versatility	Function as land mine when emplaced along roads or railroads; function as mine against vehicles on bridges, wharves or fords; readily convertible to bomb by replacing nose fuze

DESTRUCTOR MK 36 MILESTONE SCHEDULE (Starting date - 1 August 1966)

Design of weapon seals to withstand static and dynamic water pressures	15 Sep 1966
Overall weapon system tests	
Bottom stability	15 Nov 1966
Explosive countermeasures	5 Dec 1966
Vessel and Vehicle response	24 Oct 1966
Weapon system safety and reliability review	3 Jan 1967
*Total operational tests	5 Dec 1966
Development of firing device	
Five preliminary engineering models	30 Sep 1966
Twenty improved engineering models	30 Nov 1966
Twenty-five pre-prods for OPTEVFOR	15 Feb 1967
*Determine weapon performance at air/water, water/bottom interfaces	6 Oct 1966
*Facility and services required	

\*Determination of resistance to electromagnetic radiations  
 Component tests  
 Overall weapon tests

30 Sep 1966  
 3 Jan 1967

Modification of M904 nose fuze with ML34 Adapter Booster

15 Sep 1966

\*Facility and services required

As demonstrated by the performance of the DST Mod 0 in the field, all of the original weapon specifications were met and in many instances exceeded. This was accomplished in what was considered a very accelerated development schedule.

# Soviets May Arm Ships Going to North Viet Ports

MOSCOW, Jan. 4 (UPI)—The Soviet Union charged Saturday that U. S. bombing of a Soviet cargo ship in Haiphong harbor was deliberate and "cunning" and said Soviet ships going to Vietnam may have to arm themselves.

The Soviet Government news agency said.

**OUT OF COMMISSION**  
 Eight bombs fell around the vessel, Investia said, the first exploding 25 minutes after the attack.

The note warned that Soviet ships bound for Vietnam must "take measures" to protect themselves, raising the possibility of a new arms race.

## N. Viet Harbors to Be Swept

# U.S. Ready to Clear Mines

By George C. Wilson  
 Washington Post Staff Writer

Counter-measures Squadron sound made by certain sizes of ships.

The Navy is putting together a...

The U.S. Seventh Fleet lying off Vietnam has conventional minesweeping ships that are expected to play a role in the clearing operation. The timing on when the mine-

# Haiphong: U.S. Should Clear Mines

By Murray Marder  
 Washington Post Staff Writer  
 HAIPHONG, Jan. 21—North Vietnam's major port, its lifeline to the sea mined with concealed American weaponry, will still have to deal with special hazards.

bruised city said today. Since the United States planted the mines, said Mayor Le Due Thinh, think it is also the responsibility of the Americans to remove them. "We of course hope sweep them away as soon as we can," said the mayor.

# Soviet Ship Damaged In Raid on Haiphong By U. S., Russia Says

Note Charges  
 Bomb Blast

[In Washington, the U. S. State Department declined immediate comment.]  
 The Soviet broadcast said the ship through holes in the hull.

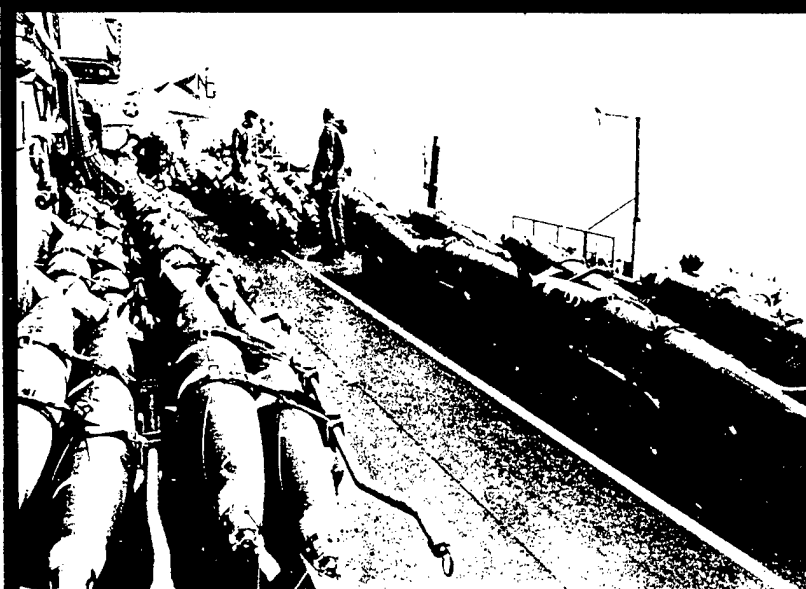
"As a result of the blast, all mechanisms and a pipeline were dislodged in the engine room, water is flooding into the ship through holes in the hull, while the number have been lost."

San Valley leading into the big base city of Da Nang. Other American Division soldiers and U. S. Marines below the Demilitarized Zone (DMZ) reported numerous skirmishes.

# U.S. Laid 11,000 Viet Mines

The Pentagon disclosed yesterday that 11,000 were sown in North Vietnamese waters between December last year and December of this year. Vice Adm. Jero said there was so that small North vessels on inland waters were damaged. But 26 freighter Haiphong harbor dependent Nixon order etnamese waterw were untouched. King, a staff of for the Joint Chiefs said Navy A6 and dropped mines a December off No coast.

Describing "slow-replicative clearing process. Navy hopes to part of the mine erations by mic weather and with the North over how to cor may push bac date. King said Na erations in Ha itself should next month



# Navy Is Preparing To Sweep Mines

DESTRUCTOR MK 36  
 U.S.S. ENTERPRISE  
 JAN 1972  
 OFF THE COAST OF VIETNAM

in the world. It went sh a training exercise in Mediterranean. About 12 ally rigged choppers are ed to the squadron. lagon specialists said the n mines dropped from e into North Vietnamese s are "virtually unsweep-

considered minelaying less provocative than an out-and-out blockade where U. S. Navy ships would have to challenge Russian ones. The Joint Chiefs of Staff long had recommended that North Vietnam's harbors, especially Haiphong, be swept



## INFORMATION FROM THE FIELD

Just at the time NOL was beginning to question the performance of the DST weapon, an account by Izvestia of a bombing mission over Haiphong appeared in the press. It was 1968 when DST's were inadvertently dropped around a Russian freighter. Eight were dropped--one embedded in a barge, within 25 minutes, the account states, the weapon on the barge detonated. Subsequently, as the freighter was backed out of the Harbor seven more detonations were observed over a period of several hours. This was an excellent reliability report--eight dropped, eight detonations--it came at a time when the SEA performance of the weapon was unknown. Probably the only Naval weapon unknowingly evaluated by the Russians. The report went on to state that the freighter suffered considerable internal damage. Simple weapons tend to be reliable.

Once the DST's were extensively used, intelligence reports indicated that various ways of countering the weapon were being tried. This came as no surprise to those working in the mining community, but as a result of this intelligence feedback minor changes to the weapon performance were initiated about every 9 months. This seemed to be the average turn-around time for countering the counter. Simple changes cause significant delays.

Not until 1969 did two agencies, both vitally involved in the SEA conflict, meet. Defence Intelligence and NOL exchanged information--what might be needed and what could be developed. DIA and CINCPAC reports on mine effectiveness were essential for weapon improved performance.

It has always been NOL's goal to provide safe and reliable ordnance as has been accomplished with the DST. It is also NOL's goal to anticipate future needs so that simple and effective modifications to existing ordnance can be provided in a timely fashion. Between the years 1967 and 1972 many such developments were undertaken to improve the performance of this weapon. I will not attempt to cover these in detail, but only the highlights. Six mods of the weapon using several bomb cases were released to the Fleet during this period. In addition to a weapon usable on land or water, several other unique features were developed. The use of a steel collar ruggedized the Arming Device to permit free-fall and subsequent burial; introduced no component testing in the field; use of cut-out tabs permitting many options; addition of seismic sensor provided additional intelligence; 7-year battery storage life provided.

Following the original Mod 0--now obsolete, each new mod provides additional performance characteristics.

Mod 1 -- A probability actuator was added for improved countermeasure protection--selectable delay arming periods added

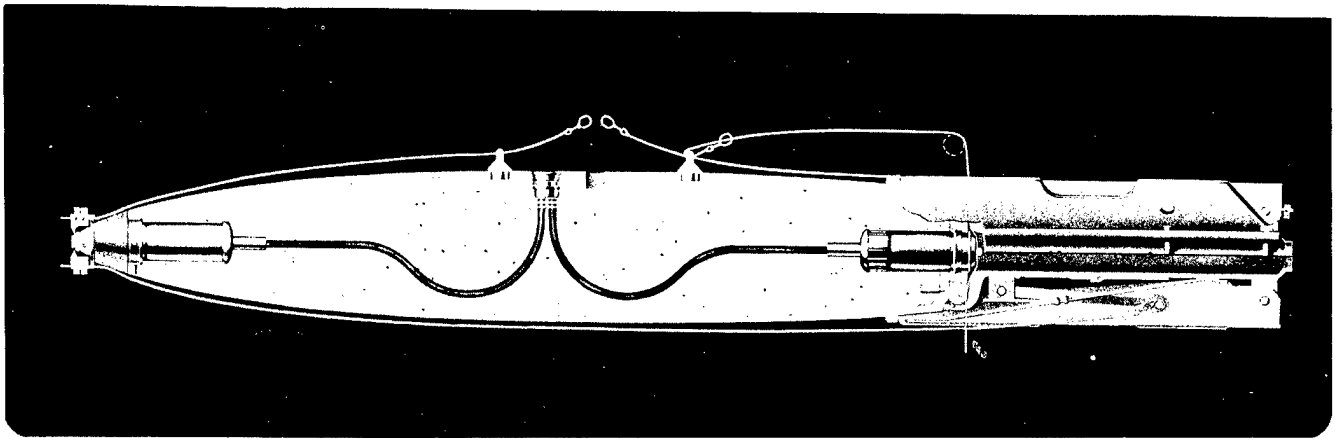
Mod 2 -- Free-fall delivery capability on land was provided--selectable self-destruct periods added

Mod 3 -- Selectable sensitivity option provided and an impact-shock feature included in the arming sequence

Mod 1A -- Upgraded the Mod 1 Kit to provide a free-fall delivery capability

Mod 4 -- Magnetic-seismic combination influence option was added, also more operational settings were provided

Mod 5 -- Magnetic-seismic combination influence with an option for improved countermeasure resistance over the Mod 4



## DEVELOPMENTS FOR ANTICIPATED NEEDS

DST KIT COMPARISON CHART illustrates how versatility and weapon effectiveness improved with time. Other developments to cover anticipated needs completed during this period but not produced were:

1. Combination pressure-acoustic mode of operation was developed for shallow-water use.
2. Integrated circuit techniques were introduced to mine mechanism designs. This extended the mine processing capability by several orders of magnitude yet maintaining reliability.
3. As a result of IC development a fully self-testing weapon system was demonstrated. Testing time-- 1/2 minute. Also, a mine system with programmable logic was bread-boarded and appears feasible. It should provide rapid response versatility and uniformity for mine mechanism designs.
4. The DST Mk 39, a surface-launched version, was developed. It was felt this weapon could be used by indigenous forces, but was not developed beyond the engineering phase.
5. Modified booster/arming device that meets HERO safety requirements for component exposure to electromagnetic radiation was developed and released. Manufacture producibility as well as safety should be improved, but no procurement has been made to date since the below-deck weapon assembly has not been objectionable to the Fleet.
6. A more compact and lighter fin with versatile optional weapon delivery modes was developed. It is called the paratail--requires less carrier storage space and should be less expensive than current Mk 15 Snakeye fin or AF MAU 91 fin. This design would be practical for both bombs and DSTs for free-fall and retarded delivery mode. It would provide unrestricted delivery tactics for the family of DSTs.
7. Developments outside the Navy utilizing the Mk 80 series bomb provided additional capability:
  - a. Laser Guidance Kit convertible to a Laser Guided Mine.
  - b. Glide Bomb modification convertible to a Glide Mine.

The weapon modifications released to the Fleet, as well as the engineering developments completed, illustrate how design improvements can be introduced into a portion of the weapon system to effectively alter its performance.

In 1971 there was a Fleet recommendation to procure more kits that could provide the anticipated free-fall delivery needs. NOL suggested that, since there were 80,000 Mod 1 Kits in the field, these be investigated to determine how much degradation could be expected from this increased impact. Tests showed that only occasionally superficial damage occurred with no functional damage when the ruggedized Arming Device Mk 32 was substituted. This free-fall delivery mode was then released to the Fleet as the Mod 1A.

Early in 1972, just prior to the mining of North Vietnam water, mines with a sensitivity option were required by the Fleet, again a new procurement for the scarce Mod 3 Kits having this option was recommended. However, as a result of design modifications by NOL to make use of space in the weapon battery, the Mod 1 mechanisms in the field could be provided the sensitivity option desired, as well as other options, in anticipation of other Fleet needs. An additional influence was provided. A seismic sensor was added in the battery. When the new battery is mated with the Mod 1 Firing Mechanism, it becomes the Mod 4 DST and makes this assembly the most versatile and effective DST to date. This mod may be operated as a combination magnetic-seismic, or a magnetic-influenced mine, and provides an increased number of selections for delay arming, self-destruct, and influence sensitivities. It improves target localization and offers an increased threat to sweepers. Equally important it enables the use of ordnance in the field to provide increased weapon operational performance.

Use of this increased weapon capability was effectively demonstrated in the 1972-1973 mining of Haiphong and other major ports. With the exception of 3 sorties of 35 each Mine Mk 52 Mod 2, the blockade was accomplished with deployment of some 11,000 DST Mk 36's.

In view of the fact that carriers of the Atlantic Fleet are now supplied with DST Kits, use in deeper water depths and possibly increased damage range is anticipated. For expected mining needs at water depths in excess of 90 feet, an adapter has been developed that enables the Mk 84 (2000#) bomb to be water-tight with a DST Kit installed. Also developed was a detent, installed in the field which enables existing DST ordnance presently limited to 300-foot depths to operate to at least 600 feet. These last two items are still in evaluation and are not yet stockpiled. Free-fall delivery of the DST Mk 84 weapon in water has been investigated as to bottom burial. Tests have shown essentially no burial at water depths of 90 feet. For shallower water depths, weapon burial could be achieved and investigation as to the effects of this burial on explosive damage should be conducted. If not serious, as suspected, this capability would provide considerable protection against mine hunting since burial can be expected for free-fall delivered weapons in water depths down to ~90 feet.

Destructor Funding

	FY 67	FY 68	FY 69	FY 70	FY 71	FY 72	FY 73
In House (\$)	*1380K	2340K	2080K	1280K	910K	100K	500K
Contract (\$)	360K	220K	420K	100K	150K	100K	40K
Total	1740K	2560K	2500K	1380K	1060K	200K	540K

Program Total \$9980K

\*Original funding--\$700K released the Mod 0 weapon for deployment in 10 months. Remaining funds for additional mods together with development evaluation.

The total funding for the DST weapon from August 1966 to June 1973 was \$9980K. For this support seven system mods compatible with three explosive charge weights (500#, 750#, 1000#) were released. Additional features\* were achieved to at least the engineering-design level:

DST OPERATIONAL FEATURES (Order Developed)

Shallow Water

Road Interdiction

Delay Arming

Self Destruct

Selectable Delay Arming

Selectable Self Destruct

Probability Actuator

Impact Arming

Improved Accuracy

\*Para-tail Fin  
Limited Free-Fall Capability

Lethality Improvement

\*Surface-laid DST  
Kit Adapted to Mk 83 (1000#) and M117 (750#) bomb cases

HERO Safe, achieved for assembly in electromagnetic environment

\*Self-Testing - IC Circuitry

Multiple Influence - GAP (Pressure/Acoustic with seismic for countermine protection) Mag/seismic

Deep Water Application

\*Kit adapted to Mk 84 (2000#)  
\*Field installed detent for deep water ( 600 ft.) use

Arctic Application

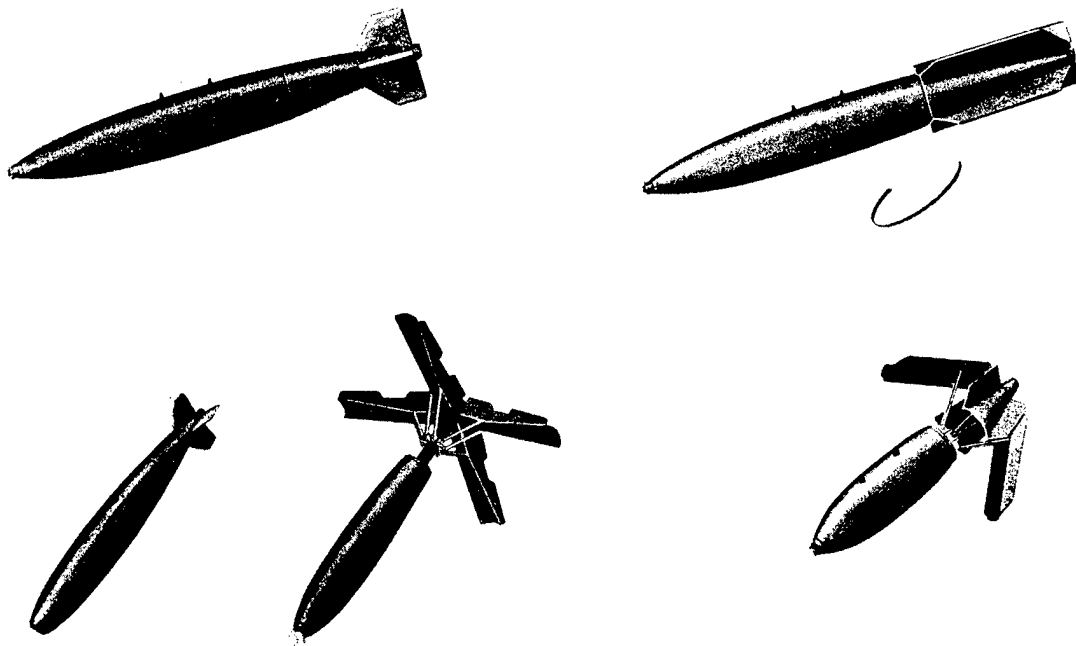
Weapon penetration through ice--feasibility established

### Lessons Learned from Design Through Production:

1. That a rapid response development is not synonymous with poor design and reduced reliability as shown by the >95% weapon performance at 90% confidential level.
2. That the development approach followed in this program in no way curbs creative thinking, as rather vividly demonstrated by the numerous unique designs released.
3. That simple designs are considerably more effective than analysis indicates.
4. A weapon need not provide all operational features that might possibly be desired--to follow this reasoning reduces considerably the reliability and exponentially increases the weapon cost. As an example: a three-day arming delay was desired for the initial mining of Haiphong to allow foreign vessels time to exist. At that time the DST Mod 4 system was just being produced and was not available--no real panic though--other mines with this arming delay period--while much less cost-effective--were utilized for this specific three-day period.
5. That by following the DST development approach substantial evaluation time and funding is saved and a more cost-effective system will be produced.
6. That weapon requirements be realistic is a must. The DST weapon would not exist if today's weapon capabilities were yesterday's requirements.
7. That yesterday's designs have considerable potential--the addition of a new component or technique can bring about amazing results.
8. That design performance is greatly affected by production procedures and techniques, e.g., the Mod 2 system was superior to earlier mods by all evaluation standards, yet exhibited a higher failure rate in the field because of production differences resulting from a different manufacturer.

It is hoped that the great potential of this general-purpose, bomb-mine weapon system will be realized. The concept and approach used in this weapon's development have come into play over and over again. We have learned how rather simple innovations to existing design can significantly improve the weapon's performance without increasing cost or complexity.

The DST which was initially a single-purpose, bomb-mine has progressed in 5 years to a small family of cost-effective land and bottom mines. The DST is logistically suited to the needs of the armed forces. By keeping the needs of the users in mind whether it be the Fleet, Air Force, Marines or the Army, further Kit improvements can be developed quickly that will provide a family of multi-purpose weapons. If this is done it will keep the stockpile needs for the more optimized but costly "special weapons" at a minimum, as well as bridge the time gap as to availability of the latter.



Independent Weapon Effectiveness Reports:

DIAIAPPR 95 A.73  
23 August 1973  
Effectiveness of U.S. Mining  
on North Vietnam

Air Force Special Communication Center  
S 264418  
COMFY COAT

## **MIREM Goals and Exercises: Past, Present and Future**

**LCDR Frank Daggett, USN**  
MIREM Program Office  
Office of the Commander  
Surface Warfare Development Group  
Naval Amphibious Base Little Creek

The Mine Warfare Readiness and Effectiveness Measuring (MIREM) Program will serve the development of the Navy's MIW capability by providing a series of exercises at sea to collect high quality data on MIW systems performance. MIREM will be a means of quantitatively assessing these systems in a tactical environment and a vehicle for tactical development. MIREM data and analysis will support fleet commanders', the MIW community's, and program office decisionmaking processes with verifiable, accurate statistical information. Building on the proven, highly successful SHAREM methodology, tailored to the unique requirements of mine warfare, MIREM will benchmark the effectiveness of dedicated and organic MCM in support of Expeditionary Warfare and become integral to the Mine Warfare improvement process.

---

Because a full paper was not received by publication date, the above Abstract appears in this Proceedings. The author can be reached at COMSURFWARDEVGRU, NAB Little Creek, 2200 Amphibious Drive, Norfolk, VA 23521-2850; telephone, 751-464-7965, X 680.





## CHAPTER 12: ACQUISITION AND MARKET STRATEGY ISSUES

The question of the viability of the Mine Warfare Systems market promises to be an increasingly important and recurring one. At the 1996 Symposium on Technology and the Mine Problem, the Session including discussion of this subject occurred in a roundtable format. There was an active, open interaction between panelists, and amongst panelists and members of the audience.

We are indebted to Mr. Ric Trotta, President of Trotta Associates, Strategic Planning Consultants, for bringing together the distinguished group of Government and Industry panelists for the Session he chaired on "Identifying and Sizing the Mine Warfare Market."

### ROUNDTABLE PANELISTS

**Dr. Louis Marquet**, Director, U.S. Army Night Vision Laboratory, CERDEC, U.S.  
Army Night Vision and Electronic Sensors Directorate, Ft. Belvoir

**Ron Blue**, Director of Undersea Systems, Electronics Sector, Lockheed-Martin

**CAPT Bill Herman, USN (Ret)**

**Robert McGurrin**, Manager of Strike System Programs, Raytheon Company

**Dr. Kathleen Robertson**, Director, Booz Allen & Hamilton

**David Rossi**, Department Head, Office of Naval Research Industrial Programs

**Vincent Schaper**, Director, Small Business Innovative Research,  
Office of Naval Research

**Dr. Jay Sculley**, CEO, Allied Research; Former Assistant Secretary  
of the Army for RD&A

**James Smith**, Vice President, Aeroflex Laboratories

We are especially indebted to Mr. Ed Zdankiewicz, outgoing Deputy Assistant Secretary of the Navy for Undersea Warfare, who chose this Symposium on Technology and the Mine Problem to give his valedictory address after years of public service. A precis of his remarks, taken from his notes by Prof. Albert M. Bottoms, appears in this Chapter.



Precis of Remarks by

**Mr. Ed Zdankiewicz**  
Deputy Assistant Secretary of the Navy  
for Undersea Warfare

Through the efforts of RADM John D. Pearson, USN, RADM Dennis R. Conley, USN, and RADM Richard D. Williams III, USN, there have been many positive accomplishments in Navy Mine Warfare. These accomplishments, and the matters that Mr. Zdankiewicz addressed, all relate to how we build toward the "Navy after Next."

Of course, there are the needs of money, streamlining the acquisition process, stability and consistency, and awareness of the opportunities conferred by the emphasis on "jointness." The availability of money is both the real measure of viability and the main tool for acquisition. Though comptrollers tend to "tax" weak programs (making them weaker). Nevertheless, the Navy's money is up in constant dollars since World War II.

The "main event" this fiscal year (FY97) will be the Quadrennial Defense Review. We can expect:

- \* Leaner budgets
- \* Smaller forces
- \* Questioning of basic assumptions (such as being able to prosecute a two-ocean war)
- \* A decision on the part of claimants to opt for cooperation or rivalry

Mr. Zdankiewicz noted that General Sheehan has been frustrated by the lack of fiscal support; RADM Conley's funds are minimal for dealing with the obstacle problem; and there are differences of opinion on whether and how the ACTD process relates to formal Acquisition. (Rapporteur's comment: The Army has a saying, "If it ain't in the POM, it ain't in the Program.")

With regard to Requirements, the needs are changing and perceptions have not yet stabilized since the fall of the Soviet empire. Clearly, there are new missions as well as, in some cases, greater emphasis on old missions. This often makes it difficult to follow the first rule of successful acquisition planning: "Stick to a game plan!"

As for the Quadrennial Defense Review, Navy assessments of ASW and Mine Warfare will have to fit new guidance. But the Mine Threat will not stand still. Therefore, we will increasingly use Commercial off-the-Shelf (COTS) technology and software controls to shorten acquisition cycles.

As an aside, Mr. Zdankiewicz pointed out we must be concerned about potential littoral warfare adversaries who will use submarines and mines together in an intelligent fashion. Thus, the miner may not be as sophisticated as we are, but he may be smarter. The miner plays from a different

“rule book,” with different objectives. He has the advantage of making the first move and loves the technical/tactical challenge presented by Naval Special Warfare MCM devices, as it presents him with a new “marketing opportunity.”

Another important point: We need to think Undersea Warfare (UW), not just Mine Warfare (MIW) or Anti-Submarine Warfare (ASW).

Mr. Zdankiewicz noted the lack of papers on offensive mining (they were not available because of classification). He pointed out that mines can assist in balancing the problem of having to meet greater navy commitments with smaller forces.

Mr. Zdankiewicz also picked up on a comment by Major General Clair F. Gill, USA, to the effect that the MCM approach lacks synergy -- researchers don't understand the operators, and vice versa. Yet, as Major General John E. Rhodes, USMC, pointed out, MCM is critical to the doctrine of Operational Maneuver from the Sea.

A note of caution: Don't define our future requirements by the period just ended; i.e., post-Cold War.

Consistency is very important in the Acquisition Process, and the Navy, especially, needs to improve in this area. Comptrollers can “smell” inconsistency. You can't have program stability without consistent requirements. An impediment to this is the constant rotation of senior leadership (in this, Mine Warfare is a microcosm of the difficulties affecting all programs).

On the upside, Congress is a consistent supporter of Mine Warfare. Congress insists on the Navy presenting a Mine Warfare Plan, and is prepared to make SECDEF certify that the plan is funded in the out-years. On the downside, the Navy's lack of consistency leads to “quick-fix” partial solutions and the addition of extra cycles and unnecessary time delays as partial solutions “steal” resources and often generate shortfalls in support.

In fairness, Mr. Zdankiewicz pointed out that the Assistant Secretary of the Navy's crusade for stability is noble, but extremely difficult to bring to fruition when readiness is being supported out of the modernization fund, all systems must now bear the “tax” resulting from operations in Bosnia and Zaire, etc., and there are additional claims for unplanned, unbudgeted efforts.

Improved “jointness” is one of the bright spots, both with other U.S. forces and with our allies, and it is affirmatively required by economics. Joint Strategic Forces simply would not be taking place in a better economic climate. In the future, there will also be smaller forces. We remain still uncertain about threats. And we need to operate with our allies and within coalitions.

We are grateful to Mr. Zdankiewicz for sharing his wisdom and concerns in this, his valedictory address.

Prof. Albert M. Bottoms, Rapporteur

# **Summary Overview of Roundtable on Identifying and Sizing the Mine Warfare Market**

**Ric Trotta**

President, Trotta Associates  
Session Chair

With Comments by

**Ron Blue**

Director, Undersea Systems,  
Lockheed Martin

Prior to the meeting, panelists were provided a list of potential issues for discussion and asked to be prepared to make some introductory comments on those topics. The format was to be round table discussion with considerable audience participation. The issues highlighted for discussion were:

- How large is the market US and International
- What are the products and services
- Who are the customers
- What are the issues associated with the market
- What criteria are used by industry in making investment decisions
- How are the needs communicated within government and to industry
- What are the opportunities for commercial technology insertion
- How do second tier companies get involved
- How do you use SBIR to leverage other investments or what role does SBIR play
- How could new technology WEB, CD ROM, etc. help communication

Mr. Ron Blue of Lockheed Martin Corporation provided some written comments to these issues and his comments are included as Appendix A.

The session was changed to the La Novia Room, Herman Hall Room to create an atmosphere conducive to panel interaction with the audience.

The session was introduced as a government industry panel discussing macro issues associated with mine warfare market covering: policy, market characteristics, industry investment decisions, communication of needs, leveraging investments with commercial technology and SBIR. The audience was told that the format would be informal discussion and that we wanted this to be an interactive meeting and that we were fortunate to have a diverse and knowledgeable audience on the subject. Introduced the panel and commented that our objective was to leave Al Bottoms with a summary of the issues discussed.

The La Novia room worked well and we had a full house estimated at over sixty in the audience with some very senior personnel including: ADM Thomas Hayward (former CNO), MGEN Ronald Beckwith USMC (retired), RADM Charles Horn (retired) and Mr. Ed Zdankiewicz ( Mine and Undersea Warfare). Session ran from 2:00 to 5:00 PM with one 15 minute break. Format was for brief five to ten minute comments by panelists and audience was encouraged to ask questions at any time. Discussion was lively and passionate and audience participation exceeded expectation. Format and topics worked well to stimulate discussion.

Areas discussed during meeting included:

- Humanitarian demining market characteristics
- Environmental remediation
- Changing industrial base and industry interaction
- Anti personnel mine policy
- Peace keeping
- Necessity of having number 1 guy involved (CNO / CINC)
- Science and technology application
- ACTDs
- System concept
- Structural organization and ownership
- False starts
- Market size to get industry involved
- Requirements balance
- Downsizing
- CRADAs
- Technology Transfer Act
- Expanding mine warfare plan to include technology
- Platforms
- Small Business Innovative Research Program

Recommend:

Senior industry and government working group to discuss and engage issues.

## APPENDIX A - RON BLUE COMMENTS

### MINE WARFARE ASSOCIATION

#### PANEL DISCUSSION

LADIES AND GENTLEMAN, GOOD AFTERNOON. IT IS A VERY GREAT HONOR TO BE INVITED TO BE ONE OF THE PARTICIPANTS IN THIS VERY IMPRESSIVE CONFERENCE, AND TO BE INCLUDED WITH THIS GROUP OF DISTINGUISHED PARTICIPANTS. I SHALL TRY TO KEEP MY COMMENTS BRIEF AND TO THE POINT, BUT HOPEFULLY WILL CREATE SOME OPPORTUNITY FOR DISCUSSION.

FIRST, I WOULD LIKE TO DEAL WITH SOME OF THE TOPICS WHICH RIC TROTTA PROVIDED AS SOME ISSUES PRIOR TO THE CONFERENCE.

#### HOW LARGE IS THE MARKET?

THE US MARKET FOR MINE WARFARE IS LIMITED BY THE TOA WHICH THE MISSION AND RESOURCE SPONSOR HAS TO SPEND. AT VARIOUS MEETINGS AND SYMPOSIA THAT NUMBER CONSISTENTLY IS PRESENTED AS RANGING BETWEEN \$250M AND \$300M PER YEAR FOR R&D AND PROCUREMENT. THIS REPRESENTS APPROXIMATELY 1% OF THE TOTAL NAVY AMOUNT. THIS TOTAL IS SPLIT BETWEEN BOTH OFFENSIVE AND DEFENSIVE MINE WARFARE, AIRBORNE AND SURFACE MINE COUNTERMEASURES. SUFFICE IT TO SAY THERE ARE NO MULTI-HUNDREDS OF MILLION DOLLAR PROGRAMS - OTHER THAN IN SHIP CONSTRUCTION - AND WE ARE RAPIDLY NEARING THE END OF A RECENT MAJOR MCM SHIP CONSTRUCTION PERIOD.

WORLDWIDE THE MARKET IS CLEARLY MANY TIMES LARGER, MANY COUNTRIES SPEND SIGNIFICANTLY LARGER PORTIONS OF THEIR DEFENSE BUDGET ON MINE WARFARE, BUT IN REAL DOLLARS IT IS PERHAPS TRIPLE OR QUADRUPLE AT BEST. ON THE DOWNSIDE IS THE FACT THAT THIS IS AN AREA IN THE WORLD MARKET WHERE THERE ARE A LARGE ARRAY OF COMPETITORS, WHO ENJOY A DEGREE OF INCUMBENCY IN THEIR RESPECTIVE NICHE'S, AND ARE DIFFICULT TO OVERCOME - AND MOST IMPORTANTLY ARE OFTEN INDIGENOUS SUPPLIERS.

#### WHAT ARE THE PRODUCTS?

THE PRODUCTS RUN THE GAMUT FROM FULL UP WEAPON SYSTEMS, COMBAT SYSTEMS, SENSOR SYSTEMS, COUNTERMEASURE SYSTEMS WHICH ARE A COMBINATION OF HARDWARE AND SOFTWARE. THE PRODUCTS TEND TO BE DOMINATED BY ACOUSTIC SENSORS AND SIGNAL PROCESSING, WITH MOVES NOW INTO ELECTRO-OPTICAL AND MAGNETIC



SENSORS. THE MINECLEARING SYSTEMS EMPLOY ACOUSTICS, MAGNETIC, MECHANICAL DEVICES AND ARE EMPLOYING VARIOUS EXPLOSIVE TECHNIQUES FOR CLEARING OF SHALLOW WATER MINES. INFORMATION AND INFORMATION PROCESSING, MISSION PLANNING, AND C4I ARE EMERGING AREAS WHICH ARE REQUIRED TO COORDINATE AND DIRECT THE GROWING AND DIVERSE PLATFORMS - BOTH ORGANIC AND DEDICATED.

WHO ARE THE CUSTOMERS?

THIS IS NEVER AN EASY QUESTION TO RESPOND TO. FIRST WE ARE ALL CUSTOMERS, SINCE WE ARE THE SOURCE OF THE REVENUE WHICH PAYS ALL THE BILLS. THE NAVY MARINE CORPS TEAM IN THE FIELD ARE THE CUSTOMERS, IN THAT THEY ARE THE USERS, OPERATORS AND BENEFACTORS OF THE VARIOUS SYSTEMS PROCURED FOR OUR COMMON DEFENSE. THE TYPE COMMANDER AND THE FLEET CINC'S ARE ALSO PART OF THE CUSTOMER CHAIN IN THAT THEY FORMULATE AND PRIORITIZE THE REQUIREMENTS, AND EMPLOY THE SYSTEMS DEVELOPED IN RESPONSE TO THEIR REQUIREMENTS. THE PEOPLE IN THE VARIOUS POSITIONS IN THE PENTAGON ARE PART OF THE CUSTOMER CHAIN IN THAT THEY DEVELOP THE PROGRAM ALTERNATIVES AND PLAN FOR AS WELL AS BUDGET AND DEFEND THE PROGRAM. THE FOLKS IN THE ACQUISITION SIDE OF THE NAVY - IN PEO'S, SYSTEMS COMMANDS, AND FIELD LABORATORIES - ARE A PART OF THE CUSTOMER/SUPPLIER END OF THE PROCESS. THEY DEVELOP THE DETAILS OF TECHNICAL ALTERNATIVES, ASSIST IN DETERMINING THE BEST VALUE SOLUTION, DEVELOP HIGH RISK TECHNOLOGY OR DO PROTOTYPING IF REQUIRED. ULTIMATELY THEY THEN PROCEED WITH THE ACQUISITION OF WHAT'S DECIDED TO MEET THE REQUIREMENTS. INDUSTRY SUPPLIES THEIR OFFERINGS TO THE ACQUISITION SIDE, AND ULTIMATELY THE SYSTEM IS FIELDDED TO THE ULTIMATE CUSTOMER, THE PERSON IN THE FIELD/FLEET. CONGRESS IS A PART OF THE CUSTOMER CHAIN, AND THEIR ROLE IS TO ENSURE THAT WE - THE BILL PAYERS - GET WHAT WE PAY FOR, THE BEST DEFENSE POSSIBLE FOR THE DOLLARS EXPENDED. SO LIKE SO MANY OTHER THINGS IN TODAY'S' WORLD, WE ARE ALL INVOLVED IN SOME MANNER IN BEING BOTH A PART OF THE CUSTOMER IN SOME RESPECTS, AND A PART OF THE SUPPLIER IN OTHERS.

WHAT OPPORTUNITIES ARE THERE FOR TECHNOLOGY INSERTION/ALTERNATIVES?

I BELIEVE THAT THERE ARE OPPORTUNITIES WHEN THERE IS A VALID REQUIREMENT, THERE IS A PROVEN TECHNOLOGY, WHICH CLEARLY

PROVIDES A BETTER REQUIRED CAPABILITY AT AN AFFORDABLE PRICE. THE TECHNOLOGY MUST BE SUFFICIENTLY MATURE, ROBUST, AND SUPPORTABLE SO THAT IT WILL CLEARLY MAKE A DIFFERENCE. MARGINAL IMPROVEMENTS, NOVELTIES, TECHNOLOGY FOR TECHNOLOGY SAKE ARE JUST NOT WORTH ANY OF OUR TAX DOLLARS. WE MUST ENSURE HOWEVER, THAT WE HAVE A SUFFICIENT INVESTMENT IN TECHNOLOGY TO MAKE SURE THAT WE HAVE WHAT WE WANT WHEN WE NEED IT. IF WE INVEST TOO LITTLE OR NONE AT ALL, THEN WE WILL BE CAUGHT SHORT. HOWEVER, IF WE JUST DEPEND ON TECHNOLOGY INVESTMENT, BECAUSE THERE IS SOMETHING BETTER, THEN WE WILL NEVER HAVE WHAT WE NEED IN THE FIELD. THIS IS A PRECARIOUS PROCESS WITH MANY PITFALLS.

#### HOW DO OTHERS GET INVOLVED?

THERE ARE A MYRIAD OF WAYS TO GET INVOLVED. NONE ARE SHORT, QUICK, PAINLESS. FIRST, UNDERSTAND WHAT THE PROBLEM IS. SECOND, WHAT HAVE YOU GOT WHICH WILL MAKE A DIFFERENCE. THIRD, WHAT ARE YOU WILLING TO DO TO CONVINCING THE "CUSTOMERS" THAT YOUR PRODUCT/PROCESS/TECHNOLOGY IS BETTER, FASTER, CHEAPER - HOW DO YOU PROVE IT? FOURTH, BE WILLING TO SPEND TIME AND MONEY, MEET, BRIEF, PRESENT, RESPOND - PERHAPS FOR MONTHS OR YEARS. PARTICIPATE IN THE VARIOUS ORGANIZATIONS. ANY OF THESE AREAS HAVE A COMMON THEME, THERE IS NO "GET RICH QUICK" AND THERE IS NO "MAGIC SOLUTION". IF ALL PARTS OF THE CUSTOMER CHAIN RECOGNIZE THIS THEN THERE CAN BE ENDURING, FRUITFUL, AND MEANINGFUL PARTNERSHIPS ESTABLISHED TO MEET NATIONAL REQUIREMENTS.

#### HOW DOES INDUSTRY REALLY GET INVOLVED?

USUALLY BY MAKING A CERTAIN LEVEL OF COMMITMENT, DEVELOPING THEIR OWN CONVICTIONS - NOT JUST TAKING SOMEONE'S WORD, FIGURING OUT WHAT THEY CAN CONTRIBUTE, HOW IT WILL MATCH THEIR BUSINESS EXPECTATIONS, AND TAKING THE LONG VIEW - 5 TO 10 YEARS. ARE YOU WILLING TO GET INVOLVED ON THAT BASIS, WHAT ARE YOU WILLING TO DO, HOW MUCH WILL YOU INVEST OR LEVERAGE, AND WHAT RETURN DO YOU EXPECT AND WHEN. IF YOU NEED SOMETHING IN 9 OR 10 MONTHS, THE LIKELIHOOD OF TRYING TO GET INVOLVED WILL NOT BE HIGH AND YOUR LEVEL OF FRUSTRATION WILL ONLY INCREASE. TIMELINES ARE DECREASING, BUT WE ARE STILL DEALING WITH A LARGE BUREAUCRATIC SYSTEM - A BUFFER OF SORTS - WHICH KEEPS OUR MONEY FROM BEING SUDDENLY SQUANDERED. IF YOU DEVELOP ALL OF

CROSS-POLLINATE. OPERATING COMPANIES ARE HOSTING "COMPANY DAYS" AS A MEANS TO INTRODUCE PRODUCTS, TECHNOLOGIES, AND PLANS TO OTHER OPERATING COMPANIES. SO WHILE THERE ARE INSTANCES IN THE NEAR PAST, AND MAY BE A FEW IN THE NEAR FUTURE, I WOULD EXPECT THAT WITHIN A YEAR, WE WILL HAVE THIS ISSUE BEHIND US AND WILL BE OPERATING AS A WELL COORDINATED, WELL LUBRICATED, HIGH TECH MACHINE.

THE ABOVE HAS FOCUSED ON THE INTERNAL SITUATION. CLEARLY THERE HAVE BEEN TIMES WHEN CUSTOMERS HAVE BEEN CONFUSED BY SEVERAL COMPETING SOLUTIONS FROM THE SAME CORPORATION. THE RESPONSE HAS BEEN MIXED FROM THEM. SOME LIKE THE IDEA OF HAVING A LARGE NUMBER OF DIVERSE SOLUTIONS TO SELECT FROM. OTHERS WANT THE CORPORATION TO FIGURE OUT WHAT THE BEST SOLUTION IS AND PROVIDE A SINGLE RESPONSE. NEEDLESS TO SAY IN THE LONG RUN, BOTH FROM THE SUPPLIER SIDE AND THE CUSTOMER SIDE, A SINGLE WELL THOUGHT OUT RESPONSE, INTEGRATING THE "BEST OF THE BEST" SEEMS TO BE THE RIGHT ANSWER. IT IS LESS COSTLY FOR THE COMPANY TO PROVIDE A SINGLE PROPOSAL, AND LESS COSTLY AND TIME CONSUMING FOR THE CUSTOMER TO EVALUATE.

HOW DOES A COMPANY DECIDE WHAT TO PURSUE, WHEN, HOW MUCH TO INVEST?

ANOTHER INTERESTING QUESTION. MOST COMPANIES HAVE DEVELOPED A LONG RANGE PLANNING PROCESS, WHICH IS DONE ON A YEARLY BASIS, WITH QUARTERLY UPDATES. IT IS QUITE SIMILAR TO THE DOD POM PROCESS, SO IF YOU UNDERSTAND ONE - YOU HAVE AN APPRECIATION FOR THE OTHER. IN THE BUSINESS CASE, THERE ARE FINANCIAL OBJECTIVES ESTABLISHED FOR THE COMPANY TO RESPOND TO. THE PLAN RESPONDS WITH THE APPROACH, THE COMMITMENT, AND THE RESOURCES REQUIRED TO EXECUTE. AS A PART OF DEVELOPING SUCH A PLAN, THE COMPANIES ARRAY ALL OF THE OPPORTUNITIES THEY KNOW ABOUT OR EXPECT OVER THE NEXT FIVE YEARS. THEY THEN ASSESS THE PROBABILITY OF THE PROGRAM OCCURRING, AND THE PROBABILITY OF WINNING THE PROGRAM. FINALLY AN ASSESSMENT OF THE REQUIRED INVESTMENT FOR EACH OF THESE OPPORTUNITIES IS MADE. NOT TO ANYONE'S SURPRISE THE REQUIRED RESOURCES TO PURSUE ALL IDENTIFIED OPPORTUNITIES NORMALLY FAR SURPASSES THE AVAILABILITY OF RESOURCES. SO THEN THE OPPORTUNITIES ARE PRIORITIZED - BASED ON THE VALUE AND THE COMBINED PROBABILITIES OF PROGRAM AND WIN. THIS METHODOLOGY ENABLES A LOGICAL MANNER TO ARRAY THE OPPORTUNITIES, AND APPLY RESOURCES AVAILABLE. THIS THEN HELPS IN GENERATING THE PLAN, THE STRATEGY,

THE ABOVE, THEN ANALYSIS, DEMONSTRATIONS, AND TECHNOLOGY APPLICATIONS ARE THE WAY TO BREAK IN, AND HAVE AN IMPACT.

HOW DOES A LARGE COMPANY COORDINATE BOTH INTERNALLY AND EXTERNALLY?

THIS IS A PARTICULARLY GERMANE QUESTION. AS I AM SURE MOST OF YOU ARE AWARE, MARTIN MARIETTA THROUGH THE ACQUISITION OF GE AEROSPACE, THEN PARTS OF GENERAL DYNAMICS, THEN MERGED WITH LOCKHEED WHICH ITSELF HAD ACQUIRED SANDERS AND OTHER PARTS OF GENERAL DYNAMICS, AND THEN THE NEW LOCKHEED MARTIN ACQUIRED THE DEFENSE BUSINESS OF LORAL LESS THAN 9 MONTHS AGO - WHICH ITSELF WAS COMPOSED OF VARIOUS OPERATIONS FROM IBM, UNISYS, VOUGHT, FORD, HONEYWELL, FAIRCHILD, AND GOODYEAR. TODAY THERE ARE OVER 190,000 EMPLOYEES OPERATING IN SOME 82 DIFFERENT OPERATING COMPANIES, WHICH ARE IN ONE OF SIX SECTORS.

SO THE MAGNITUDE BEGINS TO APPROACH THAT OF RUNNING A LARGE ORGANIZATION, SAY LIKE DOD, WHICH HAS A GROUP OF DIVERSE BACKGROUNDS AND CULTURES (ARMY, NAVY, AIR FORCE, MARINES). THE DIFFERENCE IS THAT THERE ARE FINANCIAL COMMITMENTS FOR ORDERS, SALES AND PROFIT - AND THERE ARE LONG TERM ESTABLISHED CUSTOMER RELATIONSHIPS E.G. ALL OF THE SUBMARINE LAUNCHED BALLISTIC MISSILES HAVE BEEN DEVELOPED AND BUILT BY THE SAME OPERATION, MOORESTOWN IS THE SOLE PRODUCER OF ALL AEGIS COMBAT SYSTEMS. AS THE MARKET SIZE CONTINUES TO SHRINK, THERE ARE MORE SEGMENTS OF INDUSTRY PURSUING OPPORTUNITIES OUTSIDE OF THEIR TRADITIONAL MARKETS. THIS WAS CLEARLY GOING ON IN WHAT TODAY MAKES UP LOCKHEED MARTIN, ALL OF WHICH HAS TRANSPIRED IN THE LAST 48 MONTHS, WITH THE BULK OF IT OCCURRING IN JUST THE LAST 18 MONTHS. SO IT IS NOT SURPRISING THAT WE FIND THAT WE ARE COMPETING WITH OTHER LOCKHEED MARTIN ORGANIZATIONS, SOMETIMES UNKNOWINGLY. WE ARE WORKING AT REMEDYING THIS, DEVELOPING APPROACHES WITHIN A SECTOR TO REMEDY CONFLICT, AND THEN WORK AT A SIMILAR APPROACH FOR INTERSECTOR DECONFLICTION WE ARE ON A PATH TO DESIGNATE LEAD OPERATING COMPANIES - LIKE THE NAVY DID A FEW YEARS BACK WITH THE LEAD LABS CONCEPT. THERE IS GREATER COORDINATION AND COOPERATION AS EACH DAY GOES BY. DURING THE RECENT LONG RANGE PLAN BRIEFINGS, EACH COMPANY HAD TO REPORT AND HIGHLIGHT AREAS WHERE THERE WERE SUCCESSES IN SUPPORTING OTHER OPERATING COMPANIES, OR HAVING BEEN SUPPORTED BY OTHER OPERATING COMPANIES. EMPLOYEES ARE BEING "CROSSDECKED" WHICH WILL FACILITATE COMMUNICATION. FIELD OFFICES ARE WORKING TO

AND TECHNOLOGY INVESTMENTS. LIKE ALL PLANS THERE IS ALWAYS A DEGREE OF UNCERTAINTY, SO FLEXIBILITY IN THE PLAN AND ITS EXECUTION IS KEY. THERE ARE MANY DIFFERENT TECHNIQUES WHICH ARE EMPLOYED, INCLUDING INCREMENTAL FUNDING OF PROGRAM PURSUITS BASED ON ESTABLISHED INTERNAL MILESTONES, A RESERVE HELD TO RESPOND TO SUDDEN CONTINGENCIES, PURSUING A GREATER NUMBER OF PROGRAMS THAN COMMITTED TO, ETC. PLANNING, GOOD MANAGEMENT, AND PROPER EXECUTION IS NOT UNIQUE TO THE GOVERNMENT, THE DEFENSE INDUSTRY, OR HIGH TECH. IT IS A DISCIPLINED PROCESS WHICH CAN AND SHOULD BE APPLIED TO VIRTUALLY ALL ENDEAVORS. IT HELPS TO ENSURE THAT THE DESIRED RESULTS ARE ACHIEVED. IT HAS BUILT IN CONTINGENCIES.

# **Appendix A**

## **The Technological Revolution in the Mine Problem**

**A Tutorial Brief  
Including Bibliographies on  
Naval Mines and Landmines**

**Prof. Albert M. Bottoms  
Ellis A. Johnson Chair of Mine Warfare  
Naval Postgraduate School**

**Pages in smaller typeface are intended  
as guides for lecturer's briefing;  
pages in larger typeface are intended  
to be converted into accompanying viewgraphs**

The views expressed herein are those of the author  
and do not necessarily represent the official positions  
of the Dept. of the Navy or of the Naval Postgraduate School



## **INTRODUCTION**

**No longer is the problem of mines relegated to the realm of military arcana.**

**In the military sense, mines on land and at sea can, and have, played the roles of "showstoppers". Mines of the most sophisticated types are readily available to organized combatant forces and to rogue groups and terrorists.**

**The magnitude of the problem of Humanitarian De-mining is of epic proportion. Today there are no clear solutions in sight. This is the challenge to technology and to national commitment.**



## **INTRODUCTION**

**\*CONVERGENCE OF FACTORS STIMULATE CONCERN ABOUT THE MINE PROBLEM**

**KUWAIT (1991) AND WONSAN (1951) THWART NAVY INITIATIVES  
IRAQ EMPLACED UPWARD OF 3 MILLION LANDMINES  
WORLD-WIDE HORROR AT NON-DISCRIMINATING ANTI-PERSONNEL  
MINES**

**\*REVIEW OF NAVY MINE COUNTERMEASURES TECHNOLOGY REVEALS  
"HOLES"**

**\*SOMALIA AND BOSNIA PLACE AMERICAN TROOPS AT RISK  
\*PRESIDENT PLEDGES US TECHNOLOGICAL LEADERSHIP IN  
HUMANITARIAN DE-MINING EFFORTS**

**AND, CLOSER TO HOME,**

**\*SYMPOSIUM ON AUTONOMOUS VEHICLES IN MINE COUNTERMEASURES AT  
NPS PROVIDES GLIMPSE OF WHAT COULD BE**

## **DIMENSIONS**

**A profusion of agencies and organizations within the Military Departments as well as in other Federal, State, and Local government entities have responsibilities in the problem areas shown on the figure.**

**The technical problems posed have much in common. This fact suggests that there be pooling of resources and a combination of interagency and interdisciplinary approaches so as to maximize the effect of R&D resources.**

**At the same time the operational needs of military agencies, law enforcement agencies, and civil applications - including Humanitarian De-mining - must be consciously kept in mind.**

**DIMENSIONS OF THE MINE PROBLEM (INCLUDING UXOS)**

**SCOPE**

**MILITARY COUNTERS TO MINES  
IN THE WATER AND LITTORAL  
ON LAND  
HUMANITARIAN DE-MINING  
UNEXPLODED ORDNANCE (UXO)**

**AND THE RELATED PROBLEMS**

**HAZARDOUS MATERIALS CLEANUP  
DEFANGING TERRORIST ACTIVITY  
URBAN SEARCH AND RESCUE IN NATURAL DISASTERS**

**WHAT IS AT RISK**

**A great deal!**

**In military operations the capability to execute tasks in a safe and timely manner.**

**In civil contexts, the capability to deny terrorist or rogue groups the power to disrupt, deny, and strike fear.**

**In mine-infected regions, the capability to resume economically productive use of land and infrastructure.**

**WORLD-WIDE THREAT AND IMPLICATIONS (What's at risk)**

**MINES ARE THE "WEAPONS OF CHOICE" FOR MILITARILY INFERIOR FORCES**  
**MINES EXERT GREAT LEVERAGE IN MILITARY OPERATIONS**  
**CHANNALIZE MILITARY MOVEMENTS**  
**DESTROY TIMELINES ESSENTIAL TO COORDINATED OPERATIONS**  
**MAJOR PSYCHOLOGICAL WEAPON - WEAPONS THAT WAIT**

**IN THE HANDS OF ROGUE NATIONS AND BANDS**  
**WEAPONS OF TERROR**

**U.S. ARMY ESTIMATES BETWEEN 125 AND 175 MILLION LANDMINES ALREADY**  
**IN THE GROUND AND MORE GOING IN AT RATES EXCEEDING THOSE OF**  
**REMOVAL BY AN ORDER OF MAGNITUDE.**

**THE ECONOMIC AND HUMANITARIAN COSTS ARE BEYOND COMPREHENSION**

## **POLICY ISSUES**

**Attempts to draw the analogy with chemical and biological warfare and to achieve a de facto ban on the use of such weapons have largely been unsuccessful. Military organizations in many countries point to the situations that can arise where defensive use of anti-personnel mines becomes necessary to redress force imbalances.**

**The declared policy of the U.S. is to work for a ban on the use of "dumb" anti-personnel mines - those that do not self-destruct or that do not contain some ingredient that renders them inert or easily detected.**

**POLICY ISSUES**

**THE INCREASING SOPHISTICATION OF MINE TECHNOLOGY  
AND THE PROLIFERATION OF MINES AND THEIR TECHNOLOGIES**

**CAN THERE BE AN ENFORCEABLE BAN ON "DUMB" ANTI-  
PERSONNEL MINES? SHOULD THE US DO IT UNILATERALLY?**

**TECHNOLOGY EXISTS TO MAKE LANDMINES MORE DETECTABLE NOT LESS**

**ALSO**

**LANDMINES COULD BE MADE TO SELF-DESTRUCT AFTER DESIGNATED  
PERIOD OF TIME**

**CONVENTIONS RESISTED BY COUNTRIES HAVING LARGE STOCKPILES OF OLD  
LANDMINES**

## **MINE TECHNOLOGY REMINDERS**

**Mines are readily available to any and all on the open arms market.**

**In talking about mine countermeasures, it is necessary to consider what types of mines, what the targets of the mines might be, and what features of the mines lead to countering, rendering safe, and removal.**

**This knowledge is the domain of strategic and economic intelligence to trace the flows of armaments and tactical or operational intelligence to assess intended use of mines and the types of mines being employed.**



**MINE TECHNOLOGY REMINDERS**

**WORLD-WIDE PRODUCTION**

**BIG EXPORTERS - RUSSIA, CHINA, POLAND, ISRAEL, ARGENTINA, ITALY,  
FRANCE**

**SOME 750 DIFFERENT TYPES OF LAND MINES (U. S. ARMY JOINT GROUND  
INTELLIGENCE CENTER)**

**MULTIPLE FUZING COMBINATIONS; CONTACT, PRESSURE, MAGNETIC,  
SEISMIC, TRIP WIRES**

**VARIATION IN MATERIALS OF CONSTRUCTION - INCREASING USE OF  
PLASTICS**

**SIZE FROM THAT OF A BASEBALL TO THAT OF A BOY SCOUT CANTEEN**

**SHAPES VARY FROM SPHERES TO OBLATE SPHEROIDS TO FLAT CYLINDER**

## **TECHNOLOGICAL ASPECTS (Con't)**

**In Humanitarian De-mining of areas that have been fought over and in the clean-up of U. S. military bases that are being closed and returned to the civilian communities, Unexploded Ordnance (UXO) and fragments of projectiles and bombs magnify the clean-up problem.**

**In many areas the mines and booby traps are strictly homemade, often primitive, but elegant in their simplicity (and resistance to ordinary countermeasures).**

**Operationally, it is often difficult to separate mines and booby traps from obstacles.**

**TECHNOLOGICAL ASPECTS (Con't)**

**UXO RANGE FROM BOMBS AND ARTILLERY SHELLS TO BOMBLETS AND  
FRAGMENTS**

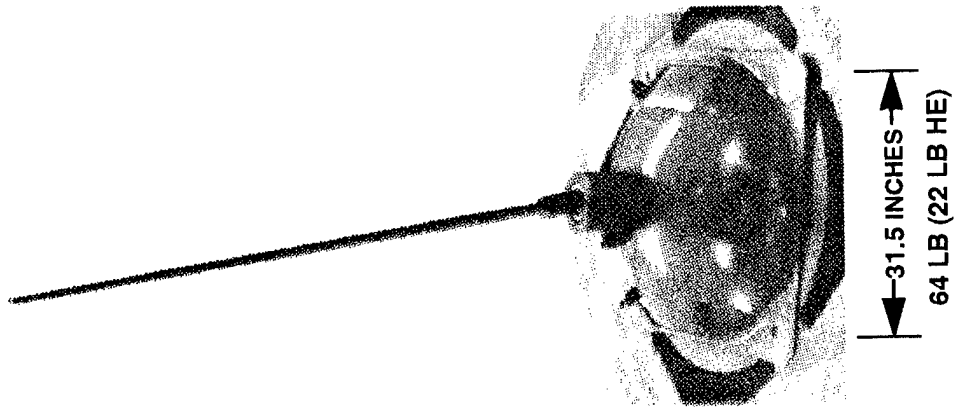
**MINES CAN BE "HOMEMADE" FROM MATERIALS OF OPPORTUNITY (COFFEE  
CANS, ETC)**

**OFTEN USED WITH OBSTACLES**

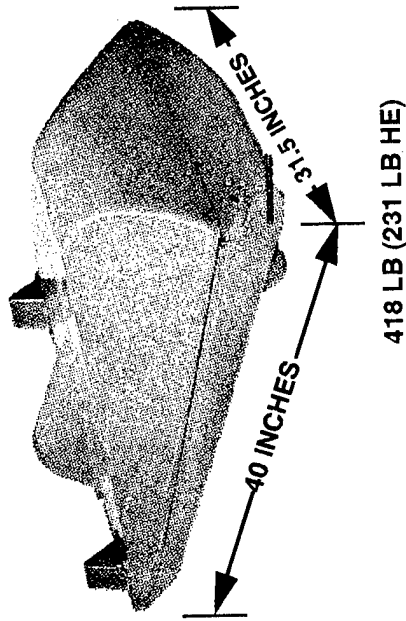
**PLACED IN ROWS OR SCATTERED**

# MINE THREAT SURF ZONE

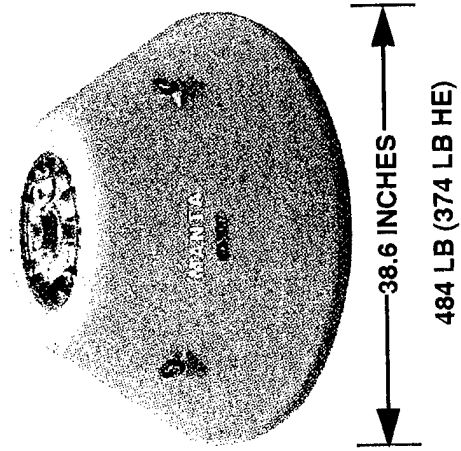
**PDM 1M**



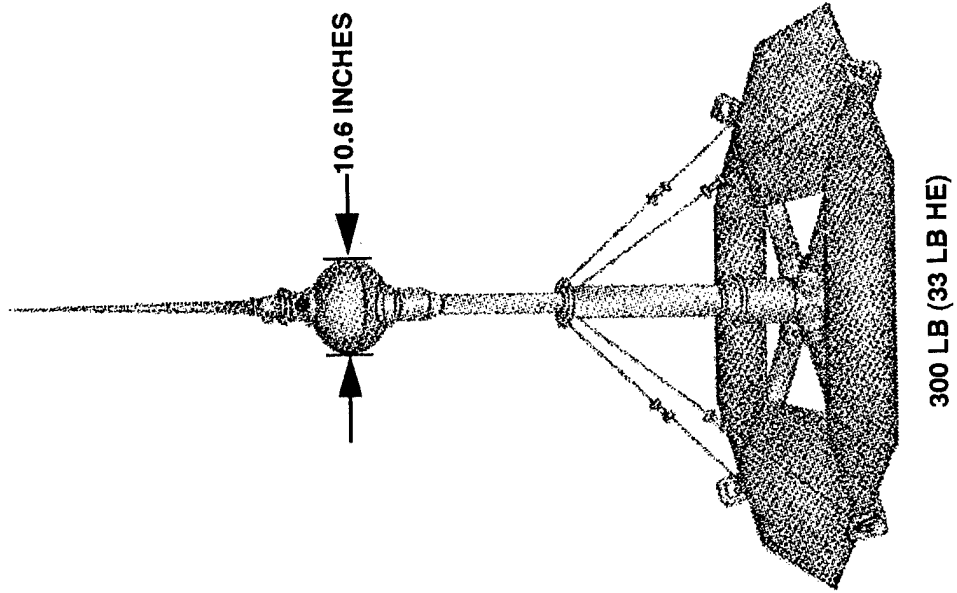
**ROCKAN**



**MANTA**

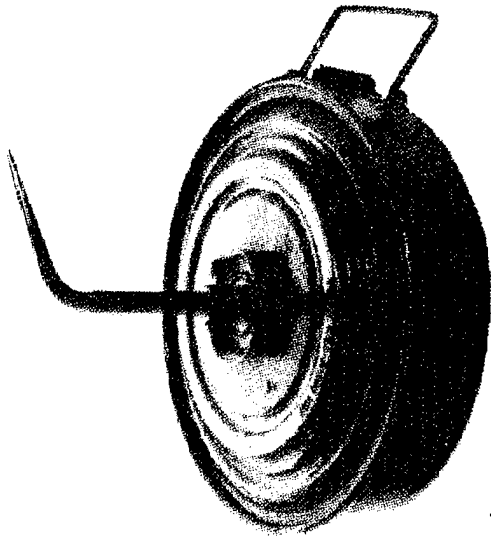


**PDM 2**



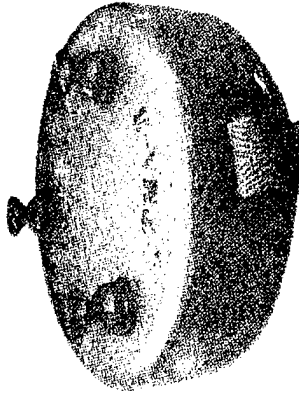
# MINE THREAT BEACH AND CRAFT LANDING ZONES

**TM 46**



12 INCHES  
18.9 LB (12.5 LB HE)

**TMA-3**



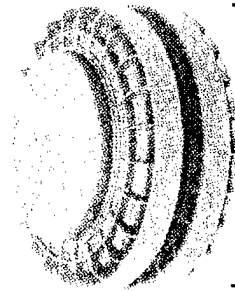
10.4 INCHES  
14.3 LB (~12 LB HE)

**TM 62M**



12.6 INCHES  
18.7 LB (15.9 LB HE)

**VS 1.6**



8.8 INCHES  
10 LB (4.8 LB HE)

## **SEA MINES**

**Sea mines and UXO in beach areas remain hazardous legacies. Since the end of World War II, some 600 commercial ships have been sunk by mines! These losses have occurred in the Home Islands of Japan and in the Channel Ports of Europe.**

**Until the Tanker War, there had been no use of floating mines. In fact, the Hague Convention requires that mines that break loose from their moorings become inert. That convention is no longer respected by all.**

**A rough rule of thumb is that water deeper than about 100 feet requires moored or rising (propelled warhead) mines. Shallower water is suitable for a variety of bottomed and buried mines.**

**Firing mechanisms possess arming delays, anti-sweep features, and target discrimination devices.**

**In the contest between the mine designer and the mine counterer, the designer is ahead.**

## **SEA MINES**

**PRODUCED (AND EXPORTED) BY 30 PLUS COUNTRIES**

**GENERALLY LARGER THAN LANDMINES ( 500 - 2000 POUNDS)**

**CONTACT AND INFLUENCE FUZING; SOME WITH ACOUSTIC HOMING WARHEADS**

**FLOATING, MOORED, OR BOTTOM - ALSO CONTROLLED (HUMAN OPERATOR)**

**SHAPES - SPHERICAL (MOORED AND FLOATING)**

**CYLINDRICAL (MOORED AND BOTTOM)**

**TRUNCATED CONE (MANTA ITALIAN MINE)**

**ROCK-LIKE (ROCKAN SWEDISH MINE)**

**MATERIALS - STEEL, PLASTIC**

**MINES CAN BE FOUND IN VERY DEEP TO VERY SHALLOW WATER**

## **WHAT WE DO NOW IN THE WATER**

The figure provides a brief description of the types of activities necessary to counter the naval mine. The pictorial illustrations provide even more graphic description of just what is involved.

The MCM-1 Class of ships is pound-for-pound the most heavily instrumented ship in the U.S. Navy. It costs about \$200 Million and has a crew of 80 highly trained and specialized individuals.

The MH-53E Helicopter is capable of carrying out influence sweeps and of doing minehunting using acoustic or electro-optical techniques.

Note the environment in which the swimmer must operate. (Illustration)



**WHAT WE DO NOW**

**IN THE WATER**

**SWEEPING - MECHANICAL, INFLUENCE -USING HELOS AND SHIPS  
HUNTING - PRIMARILY ACOUSTIC WITH VISUAL OR OPTICAL  
CLASSIFICATION**

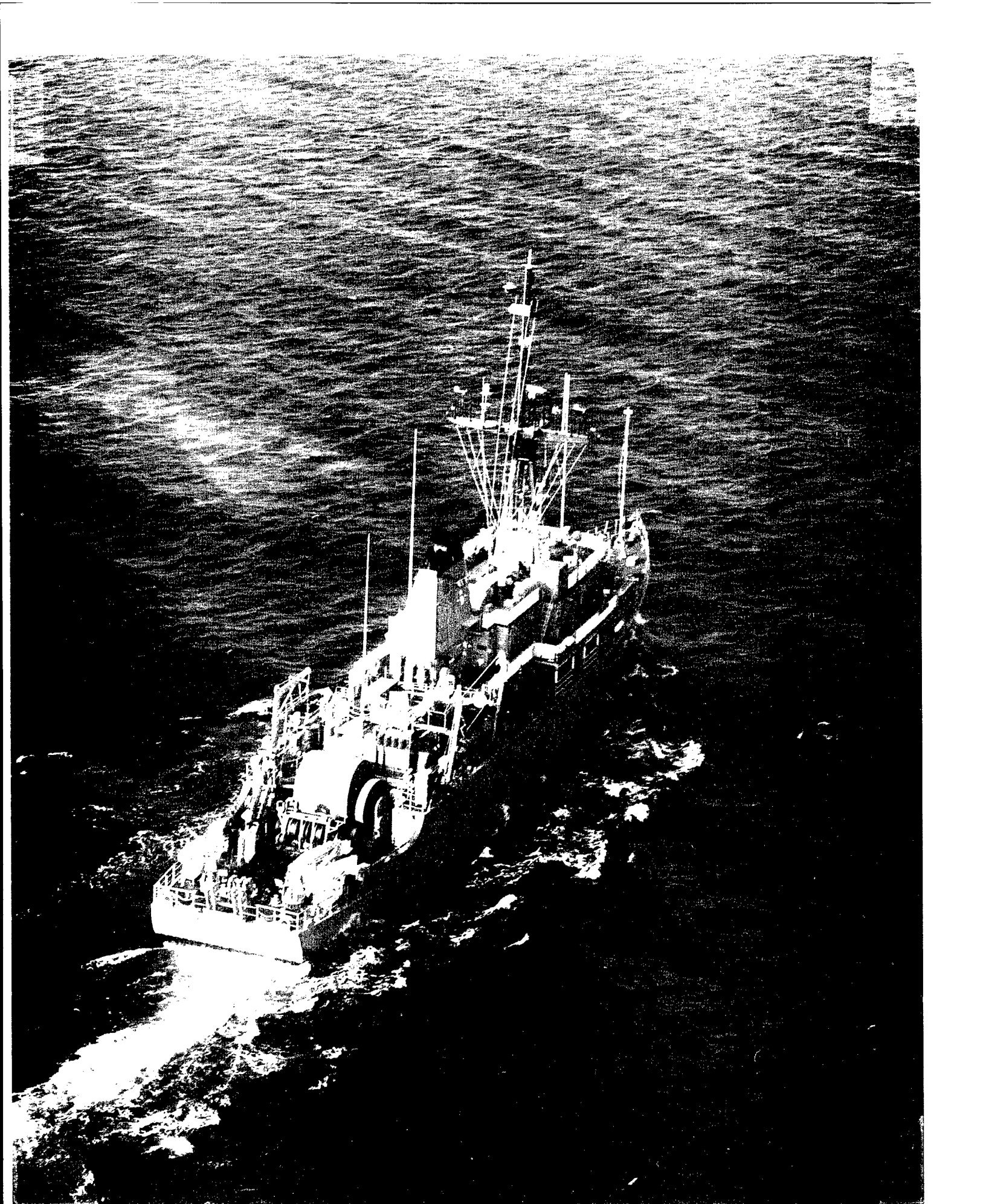
**USING SHIPS OR HELOS WITH TETHERED VEHICLES OR  
SWIMMERS**

**\*MAMMELS (DOLPHINS) VERY USEFUL PARTICULARLY FOR BURIED  
MINES**

**TEDIOUS, DANGEROUS PROCESS MADE MORE DIFFICULT BY  
PROFUSION OF FALSE (NON-MINE BUT MINE-LIKE) TARGETS**

**NEUTRALIZE - USUALLY BY SWIMMERS (DEFUZE OR PLACE REMOTELY  
COMMANDED CHARGES)  
AVOID**

**VERY SHALLOW WATER (<10FT) NEXT TO NO CAPABILITY**





## **WHAT WE DO NOW ON LAND**

**The illustrations show the brute force nature of land countermine operations.**

**Since World War I (1914-1918) generations of soldiers and marines haave relied on the bayonet as a hand-held probe for landmines. Today, in deference to the availability of magnetic fuzing, they use a plastic probe about 2 feet long! That is also the device in use in Humanitarian De-mining by personnel indigenous to the infested region.**

**The military also use hand-held magnetic mine detection sets.**

**To put the magnitude of the land countermine problem into a current context, some 18000 minefields have been reported in Bosnia as a result of the Dayton Agreements.**

**WHAT WE DO NOW (Continued)**

**ON LAND**

**AIRBORNE RECCE - VISUAL, IR, MICROWAVE RADAR  
TRACKED VEHICLES PUSHING ROLLERS OR BLADES OR PULLING  
PLOWS OR RAKES  
EXPLOSIVE LINE CHARGES AND CARPETS  
HAND-HELD ORDNANCE LOCATORS  
PLASTIC PROBES (HAND-HELD) - THE SUCCESSOR TO THE BAYONET  
(MAGNETIC)**

**CHARACTERIZED BY THE TERM "BRUTE FORCE"**

## **MINES AND OBSTACLES**

**The illustrations provide some idea of the magnitude of the engineering problem. Remember, that during actual military assault or breaching operations these mine and obstacle fields are covered by missile, artillery, and rifle fire.**

**During post-hostilities clean-up (Kuwait) and in Humanitarian De-Mining operations around the world, the covering fires are not present but the non-trivial hazards from mines and booby traps remain.**

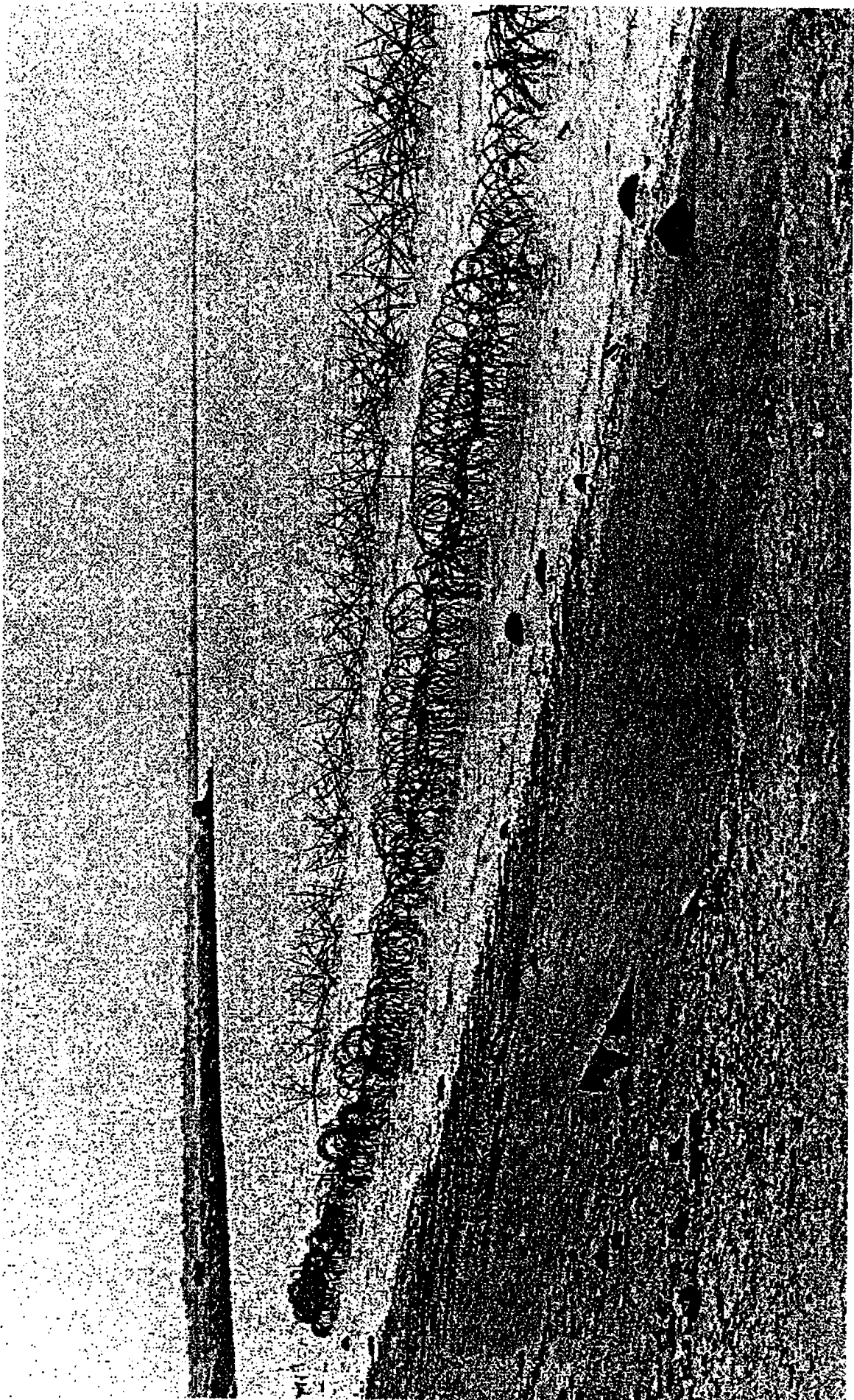
**MINES AND OBSTACLES**

**IN THE CONTEXTS OF LANDING FORCE OPERATIONS, RIVERINE WARFARE, AND  
LAND WARFARE**

**OBSTACLES AND MINES ARE FOUND TOGETHER**

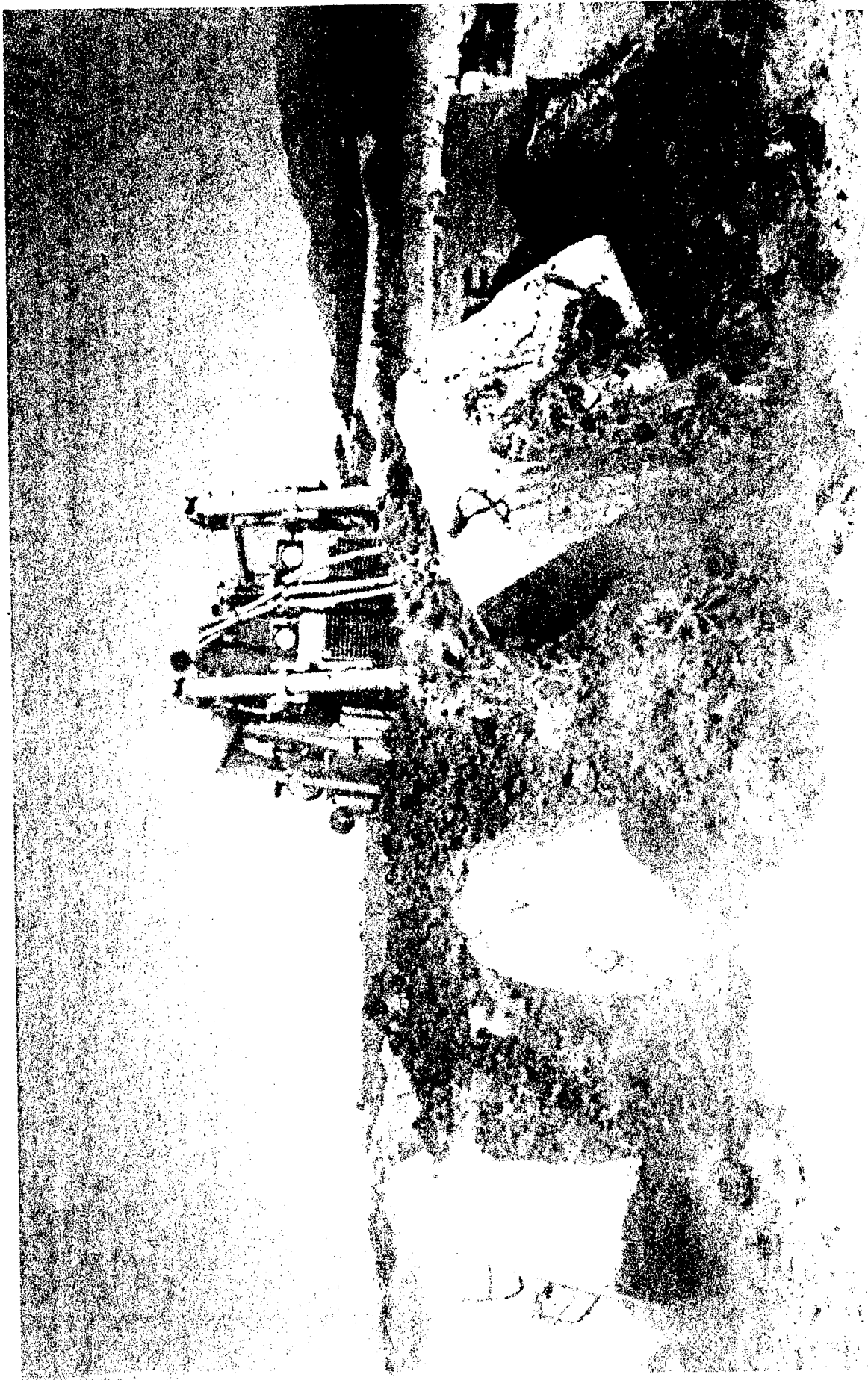
**THE MINES PROTECT THE OBSTACLES;  
THE OBSTACLES PROTECT THE MINES**

**NO CURRENT U.S. MILITARY SYSTEMS CAN OPERATE IN NATURAL OR MAN-  
MADE OBSTACLE ENVIRONMENTS**





# CLAUSEN POWER BLADE



## HUMANITARIAN DE-MINING

The question of what constitutes an affordable approach in Humanitarian De-Mining is a vexing one. The kinds of equipment - bulldozers, heavy tracked vehicles, sophisticated sensors, etc. - that the military forces of all countries employ are very capital intensive. But in a different way so is the economic impact on a mine infested region of the thousands of mine casualties and the denial of the use of land for economic purposes.

Operationally, there is a qualitative difference between military mine countermeasures and humanitarian de-mining. In the first, it is sufficient to bring the risk to the success of the military operation from mines to a level commensurate with the risks from other possible enemy actions. In humanitarian de-mining, on the other hand, it is necessary to provide assurance that the area is mine free. That is a tall order!

**HUMANITARIAN DE-MINING**

**ECONOMIC/POLITICAL CONSTRAINTS IN HUMANITARIAN DE-MINING  
U.S. FORCES CANNOT BE DIRECTLY INVOLVED IN HUMANITARIAN DE-  
MINING OPERATIONS  
SERVE AS TECHNICAL ADVISORS/TRAINERS  
NGO AND PRIVATE INTERNATIONAL CONTRACTORS ACTUALLY DO  
THE WORK  
TOOLS AND METHODS FOR HUMANITARIAN DE-MINING MUST  
BE OPERABLE BY INDIGENOUS PERSONNEL  
AFFORDABLE BY THE HOST COUNTRIES**

**RISK MANAGEMENT VS ASSURANCE  
TIMELINESS IS THE CHALLENGE IN MILITARY COUNTERMINE  
OPERATIONS  
ASSURANCE OF CLEARANCE IS THE CHALLENGE IN HUMANITARIAN  
DE-MINING**

**BOTTOM LINE: A VERY TOUGH PROBLEM  
THE CIVILIZED WORLD CANNOT IGNORE THE URGENT PROBLEM  
OF HUMANITARIAN DE-MINING**

## **THE FUTURE - THE SYSTEM OF SYSTEMS**

The functional classes of tasks in mine countermeasures/countermine are listed on the figure. The systems that perform these tasks in the water and on land must dovetail into a systemic whole - a truly seamless system of systems. In addition, in the military applications the objective is to achieve jointness - independence of military service - and interoperability. There are many historical, cultural, and logistical impediments to achieving the objective of jointness.

Perhaps the most intransigent aspect of the problem of creating the system of systems is the fact that mine countermeasures - humanitarian de-mining operations must be conducted in a variety of physical environments. These environments span the spectrum from the deep ocean through the shallow water/surf zone and on to the beach and inland environments. In each environmental segment there may be significant variations in flora and fauna.

There is no "silver bullet". It has taken a long time to recognize this fact.

**WHAT THE FUTURE HOLDS IN COUNTERMINE APPLICATIONS  
THE SYSTEM OF SYSTEMS**

**INTELLIGENCE, SURVEILLANCE, RECONNAISSANCE  
PASSIVE MINE COUNTERMEASURES  
HEAVY CONSTRUCTION EQUIPMENT  
EXPLOSIVE CLEARANCE (PELEC)  
SENSORS  
INFLUENCE SWEEPING  
AUTONOMOUS VEHICLES  
"ORGANIC" APPROACHES**

## **INTELLIGENCE, SURVEILLANCE, RECONNAISSANCE**

**The "Revolution in Military Affairs" that is occurring in this burgeoning information age is typified by the smart, operational use of information. Information and the capability to disseminate the information in useful form and in a timely manner are the essence of modern command and control. What used to represent archetypical "stovepipes" are now the enablers of modern mine countermeasures operations.**

**Emerging technology makes possible capabilities for clandestine and covert reconnaissance. These sensor, vehicle, and communications technologies come together in a system called the autonomous ocean network. This conceptual network features distributed sensors to monitor an ocean area, autonomous, programmed vehicles with different sensors to detect the presence of or introduction of mines, and covert communications capabilities to report changes or freedom from mines.**

**Intelligence is necessary if the forces are to "go where the mines are not".**

**INTELLIGENCE, SURVEILLANCE, RECONNAISSANCE**

**ECONOMIC INTELLIGENCE**

**HUMINT**

**NATIONAL TECHNICAL MEANS (RECON SATELLITES)**

**JSTARS**

**TACTICAL RECCE - AIRCRAFT, SEALS, SPECIAL FORCES**

**PLUS**

**CLANDESTINE AND COVERT RECONNAISSANCE**

**AUTONOMOUS OCEAN NETWORK**

## **PASSIVE MINE COUNTERMEASURES**

**The navigational capabilities and the capability to return to a spot that have been conferred by the Global Positioning System (GPS) represents a true breakthrough in the art of mine countermeasures - a truly enabling technology!**

**Basically, passive mine countermeasures reduce the possibility of a target-mine encounter and/or reduce the damage to the target if such an encounter occurs.**

**Most passive mine countermeasures are actions that can be taken by the targets themselves or that are incorporated in the construction of the unit.**

**Going where the mines aren't requires the outside assistance of reconnaissance or of combat engineer capabilities to install aerial tramways, causewayss, or foams to allow units relative impunity in transitting an area.**



**PASSIVE MINE COUNTERMEASURES**

**PRECISE NAVIGATION - GPS AND DIFFERENTIAL GPS  
EXPLOSION RESISTANCE  
SIGNATURE REDUCTION**

**DEGAUSSING**

**MASKING OF IR SIGNATURE**

**SPEED**

**FOAMS AND CAUSEWAYS - AERIAL TRAMWAYS**

**GO WHERE THE MINES AREN'T**

## **HEAVY CONSTRUCTION EQUIPMENT**

**The illustrations show a variety of heavy equipment that can be used to neutralize or minimize the exposure of troops and vehicles to mines. While many of these equipments could be applied to humanitarian de-mining, the unit costs are prohibitive for economically destitute third-world nations.**

**HEAVY CONSTRUCTION EQUIPMENT**

**BULLDOZERS**

**CLAUSEN POWER BLADE -ONLY INTERIM SYSTEM WITH AN ANTI-OBSTACLE  
CAPABILITY**

**TANDEM CHAIN DRAG**

**JMAC - A COMBINATION OF ROLLERS, RAKES, AND PLOWS**

**HEAVY-LIFT HELICOPTERS**

**WATTENBERG PLOW**

**LIFT SLING TO REMOVE OBSTACLES**

**ASSORTMENT OF RAKES, ROLLERS, PLOWS**

## **EXPLOSIVE MINE CLEARANCE**

**Mines in use during and after World War II were susceptible to sympathetic detonation by explosive charges placed nearby as in area bombing. The early acoustic naval mines could be spoofed by underwater explosions or by firing bursts of machine gun fire into the water. The mine designer answered with increasingly sophisticated anti-countermining features.**

**Explosive line charges and distributed fields of charges (nets) using shaped charges seek to break the mine cases and/or damage the internal mechanisms.**

**The logistics of explosive techniques are awesome to contemplate.**

**EXPLOSIVE CLEARANCE**

**PRECISION EMPLACEMENT OF LARGE EXPLOSIVE CHARGES (PELEC)- 12 -15  
THOUSAND POUND CHARGES,  
DETONATED IN ACCORDANCE WITH A TIMED SEQUENCE**

**LINE CHARGES - MODERN BANGALORE TORPEDOES**

**EXPLOSIVE NETS WITH SHAPED CHARGES  
FIRED FROM BARGES OR LAND VEHICLES  
DEPLOYED FROM REMOTELY GUIDED AIRCRAFT**

## **SENSORS**

**Sensor development is one of the most active of the mine countermeasures/countermine areas. Both in the water and on land the mine hunting process is plagued by contacts that look like mines but that are not mines. Classification of a mine like object as a mine usually requires a confirming detection by a sensor that operates on a different physical principle that the sensor making the initial detection.**

**Each of the types of sensors listed on the graphic could be the subject of a report. Each has certain capabilities in certain situations. All have significant limitations in the complex environments of the mine problem and may have restricted applicability because of size, power requirements, resolution, or range. The challenge is to exploit the complementary capabilities of several systems.**

**SENSORS**

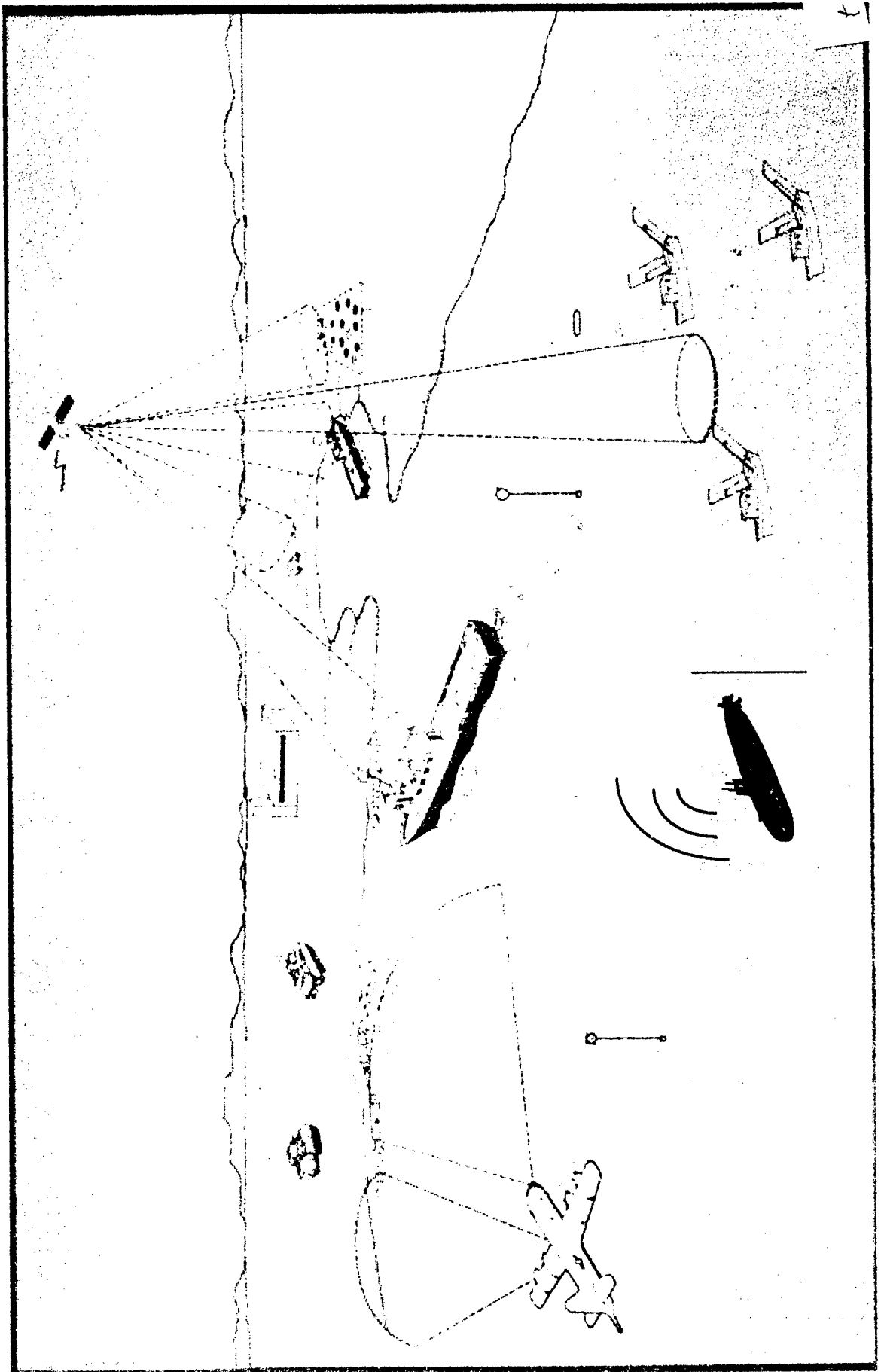
**FOR USE IN WATER**

**ELECTRO-OPTICAL (MAGIC  
LANTERN)  
LASER LINE SCAN  
MAGNETIC  
SIDE SCAN SONAR  
ACOUSTIC HOLOGRAPHY  
TV  
MAMMELS - BIO-BASED SYSTEMS  
CHEMICAL  
NUCLEAR**

**FOR USE ON LAND**

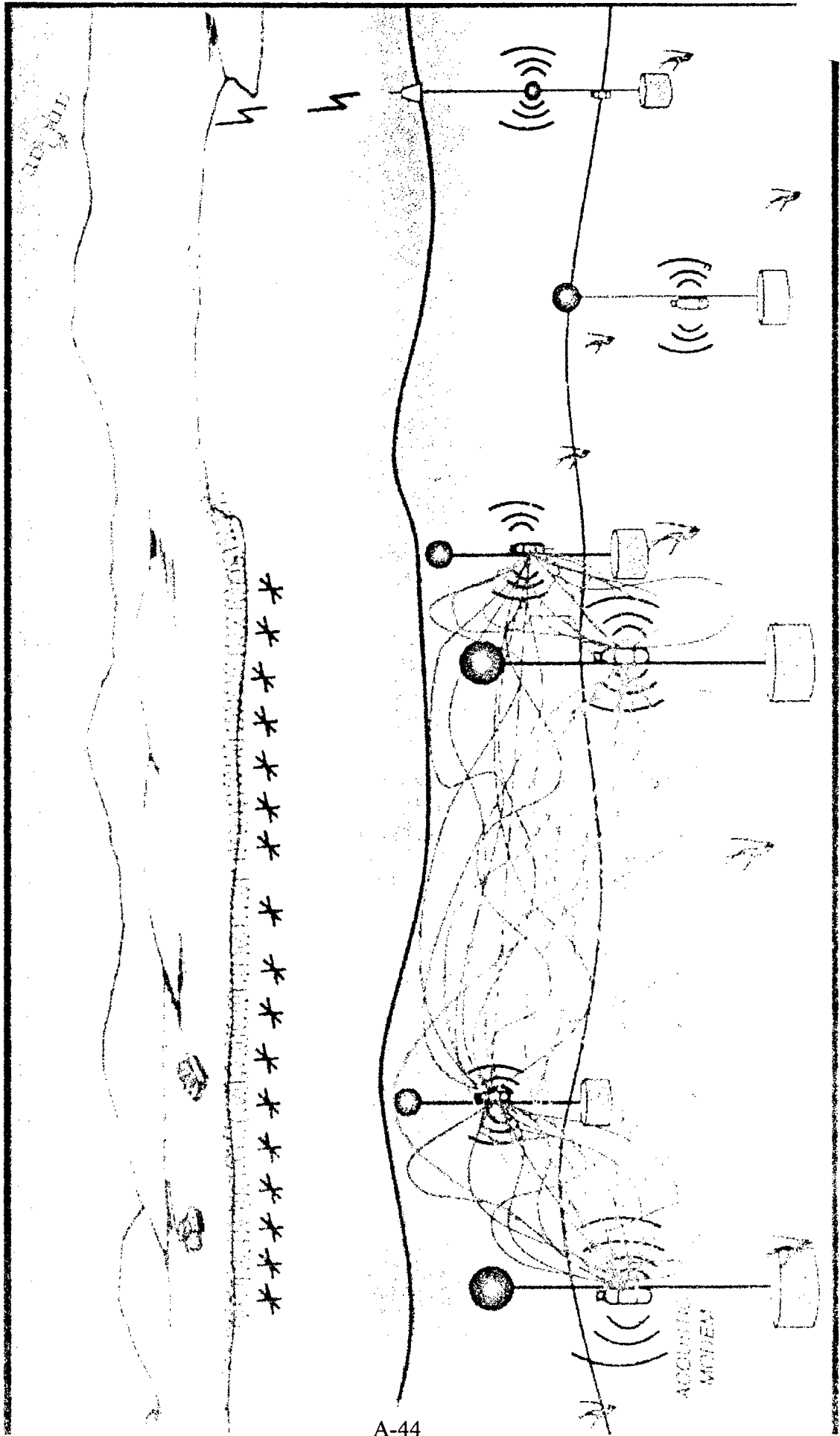
**RADAR  
MICROWAVE  
GROUND PENETRATING  
ELECTO-OPTICAL  
ACOUSTIC  
MAGNETIC  
CHEMICAL  
NUCLEAR  
ANIMALS (DOGS AND PIGS)**

# SURVEILLANCE SYSTEMS





# CLANDESTINE UNDERSEA SURVEILLANCE



## **INFLUENCE SWEEPING**

**Increased power in magnetic and acoustic sweeps has given larger sweep widths and coverage.**

**A minefield can be tailored to be most effective against a given class of target, say a carrier or a tanker. The issue is emulation in addition to simulation of the target signature.**

**INFLUENCE SWEEPING**

**FIRST GENERATION - TRICK MINE WITH SAME KIND OF INFLUENCE**

**SECOND GENERATION - REFINED "SHAPE" OF INFLUENCE PROVIDED**

**THIRD GENERATION - EMULATE THE SIGNATURE OF A SPECIFIC  
TYPE TARGET**

## **AUTONOMOUS VEHICLES**

**The mine is the world's first robotic weapon. It seems reasonable to expect that the counters could be largely autonomous.**

**The vision is a family or families of autonomous vehicles capable of doing some or all of the tasks of mine countermeasures, countermine, and humanitarian de-mining. Individual units should be affordable - in the range of \$5000 in production lots of 100,000.**

**Operationally, one envisions a hierarchy of robotic units; some for search and reconnaissance; some for classification; some for specialized tasks such as destruction of the mine or physical retrieval. Such a grouping of robots has been referred to as "The Autonomous Mine Countermeasures Brigade". The autonomous brigade is one of the systems in the "system of systems".**

**There is much R&D in industry, in academic circles, and in succch government activities as the Navy Laboratories and the Naval Postgraduate School that supports this vision.**

**AUTONOMOUS VEHICLES**

**EVOLUTIONARY PATH  
TETHERED  
PROGRAMMED  
ADAPTIVE OR AUTONOMOUS**

**REQUIRE NEW CONCEPTS OF OPERATION  
EMPLOYMENT  
TRAINING AND TACTICS  
LOGISTIC SUPPORT AND MAINTENANCE**

**FIRST STEPS - TEST BEDS FOR ENABLING TECHNOLOGIES**

**AT NPS WE BELIEVE THAT AVs WILL "CHANGE THE WORLD"**

## **"ORGANIC" APPROACHES**

**Up to the present time the Navy-Marine Corps Team had to send for specialized mine countermeasures units when problems erupted in Korea or Kuwait. The analogy is sending for the fire department instead of having fire extinguishing capabilities close at hand. The emerging technologies are those that enable this quest for organic capabilities.**

**A policy paper from the Commandant of the Marine Corps and the Chief of Naval Operations lays out this guidance.**

**"ORGANIC" APPROACHES**  
**COMPOSITION OF THE "MCM KIT" IS CHANGING**  
**WANT MCM CAPABILITIES INCORPORATED IN BATTLE FORMATIONS**  
**ANALOGOUS NEEDS FOR INDIGENOUS APPLICATIONS**  
**NAVY-MARINE CORPS "WHITE PAPER"**

## **THE WORLD-WIDE MARKET**

**The partnership among Defense Department laboratories, American industry, and America's universities has ensured America's technological lead in many areas since the end of World War II. In a market economy, industry has responsibilities to the stockholders. Investment of corporate capital and human resources - including the opportunity costs of pilot R&D - must be related to fairly identifiable returns on the investment. Development costs are high. The development cycle is long - sometimes as much as 20 years. Industry must see stable markets with the potential to permit expected return on the corporate investment.**

**These realities of the market economy are not always understood in government policy and systems acquisition circles.**



**THE IMPORTANCE OF IDENTIFYING THE WORLD-WIDE, FUTURE  
MARKET FOR COUNTERMINE SYSTEMS**

**BELIEF IN THE EXISTENCE OF A STABLE, LONG-TERM MARKET FOR MCM-  
RELATED TECHNOLOGIES AND SYSTEMS IS THE NECESSARY CONDITION TO GET  
INDUSTRY TO MAKE THE INVESTMENTS FOR SYSTEMS REDUCTION TO  
PRACTICE.**

**POST-COLD WAR US MILITARY MARKETS HAVE BEEN UNCERTAIN  
FUNDING CHANGES**

**FRAGMENTATION OF MARKETS ALONG NATIONAL LINES**

## **SUMMARY**

**The problem of mines is a new "old" problem. In land warfare mines have been used to shape the battlefield. In naval warfare mines play a variety of roles in interdiction and in causing delay. It has taken the stark realities of the lasting effects of anti-personnel landmines to raise the world's consciousness about the mine problem.**

**Technology is enabling a revolution in the approaches to mine countermeasures and, potentially, to approaches to humanitarian de-mining.**

**The major technical symposium on Technology and the Mine Problem in November, 1996, is the second in a planned series of such symposia that will take place at the Naval Postgraduate School at 18 month intervals. This event is open to all.**

**SUMMARY**

**HUMANITARIAN DE-MINING IS URGENT WORLD PROBLEM  
AT THRESHHOLD IN THE MINE COUNTERMEASURES TECHNOLOGY  
REVOLUTION  
MARKET FORCES MUST BE HARNESSED  
POLICIES - INCLUDING THOSE RELATIVE TO NGO - MUST BE CODIFIED**

**ALL THIS AND MORE WILL BE THE SUBJECTS AT THE  
SYMPOSIUM ON TECHNOLOGY AND THE MINE PROBLEM  
NOV. 18-21, MONTEREY, CA  
SEE YOU IN MONTEREY!**

**ACKNOWLEDGMENTS**

**DR. DAVID SKINNER, EXECUTIVE DIRECTOR  
COASTAL SYSTEMS STATION, DAHLGREN DIVISION, NAVAL SURFACE  
WEAPONS CENTER, PANAMA CITY, FL**

**DR. DAVE HEBERLEIN, ASSOC. DIRECTOR, AND MR "HAP" HAMBRIC  
U. S. ARMY NIGHT VISION AND ELECTRO-OPTICS LABORATORY,  
FT. BELVOIR, VA**

**MR. GEORGE POLLITT, TECHNICAL DIRECTOR  
COMMANDER, U. S. NAVY MINE FORCE, CORPUS CHRISTI, TX**

**MR. LEE M. HUNT  
NATIONAL RESEARCH COUNCIL - NATIONAL ACADEMY OF SCIENCES  
WASHINGTON, DC**

**MR. BILL BAKER  
CLAUSEN POWER BLADE, INC., MCPHERSON, KS**

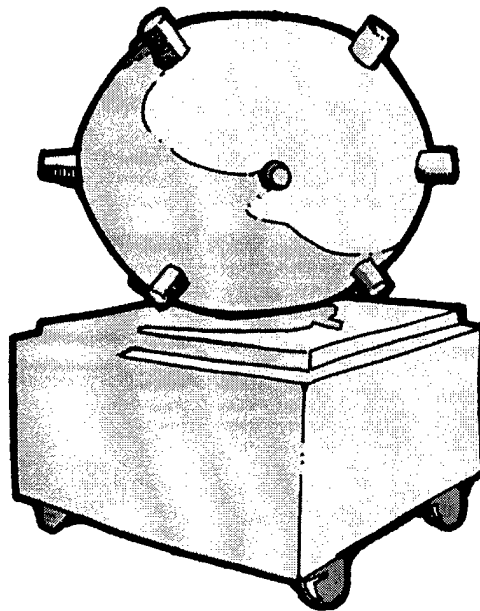
**PROF. TONY HEALEY AND DR. DON BRUTZMAN  
NAVAL POSTGRADUATE SCHOOL. MONTEREY, CA**

## SUGGESTED READING

- WEAPONS THAT WAIT**, Gregory K. Hartmann, Naval Institute Press, Annapolis, MD, 1979 294 pp. Extensive Bibliography on Naval Mines.
- AMERICA'S USE OF SEA MINES**. Robert C. Duncan, United States Government Printing Office, 1962, 173pp. Bibliography.
- "DAMN THE TORPEDOES"**, A Short History of U. S. Naval Mine Countermeasures, 1777-1991, Tamara Moser Melia. U. S. Government Printing Office, 1991. 209 pp. Extensive Bibliography including recent events (1991)
- LANDMINES A Deadly Legacy**. Human Rights Watch. 1993. 355pp plus Appendices. Bibliography of Books, Articles, Speeches, Official Documents.
- CLEARING THE FIELDS: Solutions to the Golbal Land Mines Crisis**. Edited by Kevin M. Cahill, M.D. A Joint Publication of Basic Books and The Council on Foreign Relations. 1995. 237 pp.
- JANES MINES AND MINE CLEARANCE**, Colin King, ed. © 1996 Jane's Information Group Ltd., Surrey, UK. ISBN 0-7106-1395-4 (print), 0-7106-1473-X (CD-ROM). To order, call 1-800-243-3852; Internet: <<http://www.janes.com>>.
- NAVAL MINEWARFARE**, Richard (Dick) Hansen. Turner Publishing Company, Paducah, KY, 1995. 104 pp. To order, call 502-443-0121.

# Appendix A-1

## SEA MINES AND COUNTERMEASURES, 1970-1996: A BIBLIOGRAPHY



October 1996

Greta E. Marlatt  
&  
Michael Lee Huygen

Dudley Knox Library  
Naval Postgraduate School  
Monterey, CA

**Please note: not all these resources are available in the Dudley Knox Library but they can be requested through Interlibrary Loan.**

## **BOOKS**

- Auer, James E. **The postwar rearmament of Japanese maritime forces, 1945-71.** New York: Praeger, 1973. 345 p.
- Bottoms, Albert, James Eagle, and Howard Bayless. **Proceedings of the Autonomous Vehicles in Mine Countermeasures Symposium.** Monterey, CA : Naval Postgraduate School, [1995].
- Belote, James and William Belote. **Typhoon of Steel, The Battle for Okinawa.** New York, NY: Harper & Row. 1970. 368 p.
- Bogart, Charles H. **Controlled mines: a history of their use by the United States.** Bennington, VT: Merriam Press, 1995 58 p.
- Bray, Jeffrey K. **Mine warfare in the Russian and Soviet navies.** M.A. thesis, Old Dominion University, 1989. 204 p.
- Breemer, Jan S. **U.S. Naval developments.** Annapolis, MD: The Nautical and Aviation Publishing Co., 1983. 194 p.
- Cambell, John. **Naval weapons of World War Two.** Annapolis, MD: Naval Institute Press, 1985. 403 p.
- Chen, Shih-Hsiung. **A mathematical model analysis of mine countermeasures in a harbor channel.** Monterey, CA: Naval Postgraduate School, 1996. 55 p.
- Chilstrom, John S. **Mines away! : the significance of US Army Air Forces minelaying in World War II.** Maxwell Air Force Base, AL: Air University Press, 1993. 52 p.
- Corse, Carl D., Jr. **Introduction to shipboard weapons.** Annapolis, MD: Naval Institute Press, 1975. 398 p.
- Croizat, Victor. **The Brown water navy: the river and coastal war in Indo-China and Vietnam, 1948-1972.** Dorset, UK: Blandford Press, 1984. 160 p.

- Cutler, Thomas J. **Brown water, black berets: coastal and riverine warfare in Vietnam.** Annapolis, MD: Naval Institute Press, 1988. 426 p.
- Daniel, Donald C. **Anti-submarine warfare and superpower strategic stability.** Urbana, IL: University of Illinois Press, 1986. 222 p.
- Elliott, Peter. **Allied minesweeping in World War 2.** Annapolis, MD: Naval Institute Press, 1979. 201 p.
- Else, G.H. "Anti-Mine Hovercraft : Has Their Time Come?" In **Jane's Naval Review**, edited by John Moore, p. 107-13. London: Jane's Publishing , 1986.
- Friedman, Norman. **The Naval Institute guide to world naval weapons systems.** Annapolis, MD: Naval Institute Press, 1989. 511 p.
- \_\_\_\_\_. **The Postwar naval revolution.** Annapolis, MD: Naval Institute Press, 1986. 240 p.
- \_\_\_\_\_. **The US maritime strategy.** New York, NY: Jane's Publishing Co., 1988. 246 p.
- \_\_\_\_\_. **U.S. naval weapons: every gun, missile, mine and torpedo used by the U.S. Navy from 1883 to the present day.** Annapolis, MD: Naval Institute Press, 1982. 287 p.
- Fulton, William B. **Riverine operations, 1966-1969.** Washington, DC: Department of the Army, 1973. 210 p.
- George, James L. (ed.). **The U.S. Navy: the view from the mid-1980s.** Boulder, CO: Westview Press, 1985. 385 p.
- Gerken, Louis C. **Mine warfare technology.** Chula Vista, CA: American Scientific Corp, 1989. 256 p.
- Gregory, Barry. **Vietnam coastal and riverine forces handbook.** Irthlingborough, UK: Patrick Stephens, 1981. 135 p.
- Grossnick, Roy. A. **Kite balloons to airships ... the Navy's lighter-than-air experience.** Washington, DC: Naval Historical Center, 1986.
- Griffiths, Maurice. **The hidden menace.** Greenwich, Eng.: Conway Maritime Press, 1981. 159 p.
- Gruendl, Paul L. **U.S. Navy airborne mine countermeasures: a coming of age.** Maxwell Air Force Base, AL: Air War College, Air University, 1975. 127 p.



- Hansell, Haywood S. Jr. **Strategic air war against Japan**. Washington, DC: U.S. Government Printing Office, 1980. 300 p.
- Hartmann, Gregory K. **Mine warfare history and technology**. Silver Springs, MD: Naval Surface Weapons Center, White Oak Laboratory, 1975. 43 p.
- \_\_\_\_\_. **Wave making by an underwater explosion**. Silver Spring, MD: Naval Surface Weapons Center, 1976. (NSWC/WOL MP 76-15) 167 p.
- \_\_\_\_\_. **Weapons that wait : mine warfare in the U.S. Navy**. Annapolis, MD: Naval Institute Press, c1991. 345 p. [updated edition]
- Hill, J.R. **Maritime strategy for medium powers**. Annapolis, MD: Naval Institute Press, 1986. 247 p.
- Hinge, Alan. **Mine warfare in Australia's first line of defence**. Canberra : Strategic and Defence Studies Centre, Research School of Pacific Studies, Australian National University, 1992. (Canberra papers on strategy and defence ; no. 86.) 253 p.
- Hooper, Edward Bickford. **Mobility, support, endurance: a story of naval operational logistics in the Vietnam War, 1965-1968**. Washington, DC: Naval History Division, 1972. 278 p.
- Hopper, Edwin Bickford, et al. **The United States Navy and the Vietnam Conflict. Volume I: The setting of the stage to 1959**. Washington, DC: Naval Historical Center, 1976.
- Hutcheon, Wallace S. Jr. **Robert Fulton, pioneer of undersea warfare**. Annapolis, MD: Naval Institute Press, 1981. 191 p.
- International Symposium on Mine Warfare Vessels and Systems, 1984. **Mine warfare vessels and systems**. London: Royal Institute of Naval Architects, 1984.
- Johnson, Ellis A. and David A. Katcher. **Mines against Japan**. Silver Spring, MD: Naval Ordnance Laboratory; [U.S. Govt. Print. Off., Washington, DC, 1973]. 313 p.
- Lenton, H. T. **American gunboats and minesweepers**. New York: Arco Publishing, 1974. 64 p.
- Levie, Howard S. **Mine warfare at sea**. Boston, MA : M. Nijhoff, c1992. 216 p.
- Lund, Paul and Harry Ludlam. **Out sweeps!: the story of mine sweepers in World War II**. London: W. Foulsham & Co., Ltd., 1978. 192 p.

- Lundeberg, Philip K. **Samuel Colt's submarine battery: the secret and the enigma.** Washington, DC: Smithsonian Institution Press, 1974. 90 p. [Smithsonian studies in history and technology, no. 29]
- Marolda, Edward J. **The United States Navy and the Vietnam Conflict: Volume II 1959 to 1965.** Washington, DC: Naval Historical Center, 1986. 591 p.
- Melia, Tamara Moser. **"Damn the torpedoes": a short history of U.S. naval mine countermeasures, 1777-1991.** Washington, D.C. : Dept. of the Navy, Naval Historical Center, 1991. 209 p. [Contributions to naval history ; no. 4]
- Moineville, Hubert. **Naval warfare today and tomorrow.** Oxford, Eng.: Basil Blackwell, 1983. 141 p.
- Moore, John E. **Submarine warfare: today and tomorrow.** Bethesda, MD: Adler & Adler, 1986. 308 p.
- Nitze, Paul H. et al. **Securing the seas: Soviet naval challenge and western alliance options.** Boulder, CO: Westview Press, 1979. 464 p.
- Palmer, Michael A. **Origins of the maritime strategy: American naval strategy in the first postwar decade.** Washington, DC: Naval Historical Center, 1988. 129 p.
- Patterson, Andrew, Jr. and Robert A. Winters (eds.). **Historical bibliography of sea mine warfare.** Washington, DC: National Academy of Sciences, 1977. 137 p.
- Perry, Milton F. **Infernal machines : the story of Confederate submarine and mine warfare.** Baton Rouge, LA: Louisiana State University Press, 1985, c1965. 230 p.
- Petersen, Charles C. **The Soviet Union and the reopening of the Suez Canal: mineclearing operations in the Gulf of Suez.** Arlington, VA: Center for Naval Analyses, [1975]. 29 p.
- Preston, Antony. **Navies of World War 3.** New York: Military Press, 1984. 192 p.
- Ranft, Bryan and Geoffrey Till. **The sea in Soviet strategy.** Annapolis, MD: Naval Institute Press, 1983. 240 p.
- Sallagar, Frederick M. **Lessons from an aerial mining campaign (Operation "Starvation") :** a report prepared for United States Air Force Project Rand. Santa Monica, CA: Rand, 1974. 80 p. [Rand Corporation Rand report ; R-1322-PR.]
- Stefanick, Tom. **Strategic antisubmarine warfare and naval strategy.** Lexington, MA: Lexington Books, 1987. 390 p.

**The Gulf of Suez mining crisis: terrorism at sea.** (Professional Seminar Series, United States Naval Academy, 30 May 1985). Annapolis, MD: Naval Institute Press, 1986.

**The Priorities for Australia's mine countermeasure needs.** The Parliament of the Commonwealth of Australia, Joint Committee on Foreign Affairs, Defence and Trade. Canberra : Australian Government Pub. Service, c1989. 160 p. [ Parliamentary paper (Australia. Parliament) ; no. 113/1989.]

U.S. Congress. House. Committee on Armed Services. Seapower and Strategic and Critical Materials Subcommittee. **The 600-ship navy and the maritime strategy.** 99th Congress 1st Session Washington, DC: U.S. Government Printing Office, 1988. 301 p.

U.S. Congress. House. Committee on Armed Services. Seapower and Strategic and Critical Materials Subcommittee. **Mine warfare.** 100th Congress 1st Session Washington, DC: U.S. Government Printing Office, 1988. 50 p.

U.S. Congress. House. Committee on Foreign Affairs. **The mining of Nicaraguan ports and harbors.** 98th Congress, 2nd session, April 11, 1984. Washington, DC : U.S. G.P.O., 1984. 59 p.

U.S. Congressional Budget Office. **Selected options for enhancing naval capability in regional conflicts.** Washington, DC: U.S. Government Printing Office, 1993. 29 p.

U.S. Naval Inshore Warfare Command. Task Force Sixty-Five. **Final report, Suez Canal Clearance Operation : Task Force 65.** [Norfolk, VA: U.S. Dept. of the Navy, 1975]. 114 p. [Middle East special studies, 1970-80 ; 7.]

Washburn, Alan R. **Mine warfare in NWGS.** Monterey, CA: Naval Postgraduate School, [1983]. 10 p. [NPS-55-83-004PR.]

Weber, Timothy R. **An analysis of Lemmings : a swarming approach to mine countermeasures in the VSW/SZ/BZ.** Master's thesis. Monterey, CA: Naval Postgraduate School, 1995. 91 p.

## PERIODICALS

"A Danish Convertible: One Ship For Four Combatant Tasks." **Marine Engineering/Log** September 1987 v. 92. p. 52-54.

- Aas, Halvor. "Norway's New MCM (Mine Countermeasure) Vessels: A Cost Effective Way to Combat An Elusive Enemy." **Naval Forces** 1990 v. 11, no. 5. p. 60-62+
- Ackerman, Robert K. "Airborne Detector Lays Bare Murderous Undersea Mines." **Signal** June 1994 v. 48, no. 10. p. 21-24.
- Adshead, Robin. "Minehunting." **Armed Forces** Apr 1988 v. 7. p. 165-169.
- "Advances in Mine Warfare." **Naval Forces** 1990 v. 11, no. 6. p. 49-53.
- "Aerial Minesweeping." **Defence Update International** Oct 1986 p. 42-48.
- "After the Storm: Special report." **Jane's Defence Weekly** April 6, 1991 v. 15, no. 14. p. 529-532+
- Alden, John D. "The Indestructible XMAP." **Naval History** Winter 1988 v. 2. p. 44-47.
- \_\_\_\_\_. "Tomorrow's Fleet." **US Naval Institute Proceedings** May 1987 v. 113. p. 177-186.
- Alm, Fredrik. "The Swedish Mine Counter Measure Vessel Programme." **Armada International** Feb 1985 v. 9. p. 108+
- "Amagnetic Diesels For Mine Warfare Vessels." **Marine Engineering/Log** September 1984 v. 89. p. 61+
- Annati, Massimo A. "Mine Countermeasures--ROVs (Remotely Operated Vehicles) the Second Revolution." **Naval Forces** 1995 v. 16, no. 3. p. 36-38+
- Aris, Hakki. "Mine Hunters for the Turkish Navy." **NATO's Sixteen Nations** 1992 v. 37, no. 2. p. 69-71.
- Armstrong, Harry C. "The Removal of the North Sea Mine Barrage." **Warship International** June 1988 v. 25. p. 134-169.
- Ashurov, Z. "Mines and Mine Sweeping." **Soviet Military Review** Nov 1971 no. 11. p. 29-31.
- Auld, Sonny. "First LANT COOP." **Surface Warfare** Nov-Dec 1985 v. 10. p. 10-11.
- "Avenger"--Advanced MCM Joins Fleet." **Marine Log** Jan 1988 v. 93. p. 52.
- Bakar, Rahim. "Naval Affairs: Launching and Recovery System For MCMV (Mine Counter-Measures Vessel)." **Asian Defence Journal** Nov 1990 no. 11. p. 92-93.

- Baker, Warren. "Ping-Pong Program Pings Back to U.S. (Situation Report: Arapaho)." **Sea Power** April 1986 v. 29. p. 133-134+
- Beaver, Paul. "Aerial Minesweeping: US Navy Developments." **Navy International** May 1984 v. 89. p. 305-309.
- Bell, R. and R. Able. "Mine Warfare CO-Operation." **US Naval Institute Proceedings** Oct 1984 v. 110. p. 147-149.
- Benz, Klaus G. "Mine Warfare At Sea." **Armada International** Dec 1990/Jan 1991 v. 14, no. 6. p. 28+
- Berk, Walter L. "Mine Clearance Abetted by Enhanced Technology." **National Defense** Oct 1994 v. 79, no. 501. p. 32-33.
- Blickensderfer, Thomas L. "Amphibious Mines: Silent Enemy of the Landing Force." **Marine Corps Gazette** Nov 1992 v. 76, no. 11. p. 84-87.
- Blouin, J.R. "Naval Mines and Modern Warfare." **National Defense** July-Aug 1975 v. 60. p. 39-42.
- Blunden, Alan. "Mine-Countermeasures Hovercraft." **International Defense Review** 1983 v. 16, no. 6. p. 840-842 .
- Boatman, John. "Clearing the Path to Safer Waters." **Jane's Defence Weekly** Feb 15, 1992 v. 17. no. 7. p. 243+
- Boatman, John and Mark Hewish. "Naval Mine Countermeasures: Finding the Needle in the Haystack." **International Defense Review** July 1993 v. 26, no. 7. p. 559-562.
- Booda, Larry L. "Mine Warfare Moves Ahead, Plays ASW Role." **Sea Technology** November 1984 v. 25. p. 10-11+
- Booker, R.W. "Survey Ship Goes Mine Hunting: Harkness and 'Intense Look'." **All Hands** Feb 1985 no. 815. p. 32-34.
- Boone, Terry et al. "Offboard Countermeasures: Today and Tomorrow." **Defense Systems Review** July-Aug 1984 v. 2. p. 40-44.
- Bowling, Tom. "New Mine Warfare Threat." **Canadian Defence Quarterly** Winter 1990 v. 20, no. 3. p. 17+

- Boyd, J. Huntly. "Nimrod Spar: Clearing the Suez Canal." **US Naval Institute Proceedings** Feb 1976 v. 102. p. 18-26.
- Boyles, Dennis W. "Navy/Marine Corps Team Takes a New Look at MCM (Mine Countermeasures)." **Marine Corps Gazette** Mar 1996 v. 80, no. 3. p. 32-35.
- Bray, Jeffery K. "Mine Awareness." **US Naval Institute Proceedings** April 1987 v. 113. p. 41-43.
- Breemer, Jan. "Mine Warfare: The Historical Perspective." **Naval Forces** 1988 v. 9. p. 36+
- Brill, Arthur P. "Last Twenty Feet (Mine Countermeasures in the Surf Zone)." **Sea Power** Nov 1995 v.38, no. 11. p. 43-46.
- Brown, David K. "Damn the Mines!" **US Naval Institute Proceedings** Mar 1992 v. 118, no. 3. p. 45-50.
- \_\_\_\_\_. "Design Considerations For MCMV." **Naval Forces** 1990 v. 11, no. 1. p. 31-34+
- Buchanan, Nancy. "Mine Warfare From a Different Perspective." **Armada International** Feb-Mar 1995 v. 9, no. 1. p. 20+
- Burns, Richard F. "EDO Corp.--Adjusted to the New Era." **Sea Technology** April 1996 v. 37. p. 31-3.
- Caldwell, Hamlin, A. "Air Force Maritime Missions." **US Naval Institute Proceedings** Oct 1978 v. 104. p. 28-36.
- Carus, W. Seth. "Soviet Naval Mines." **Jane's Soviet International Review** Feb 1989 v. 1. p. 50-53.
- Ceux, Jan. "Modern Minehunting." **NATO's Fifteen Nations** Feb-Mar 1982 v. 27. p. 84-85+
- Chatterton, Howard A. "The Minesweeping/Fishing Vessel." **US Naval Institute Proceedings** June 1970 v. 96. p. 121-125.
- Chichester, Michael. "Allied Navies & the Gulf War: Strategic Implications." **Navy International** June 1988 v. 93. p. 318-321.
- Chilstrom, John S. "Test For Joint Ops: USAAF Bombing Doctrine and the Aerial Minelaying Mission." **Air Power History** Spring 1993 no. 40, no. 1. p. 35-43.

- Christensen, Cyrus R. "A Minesweeping Shrimp Boat: A What?" **US Naval Institute Proceedings** July 1981 v. 107. p. 109-111.
- Chromeau, John. "Soviet Mine Warfare." **Naval War College Review** Dec 1971 v. 24. p. 94-96.
- Cislak, Jaroslaw and Jacek Krzewinski. "Minelayer/Transport Ships of the Lublin Class." **Jane's Intelligence Review** Dec 1992 v. 4, no. 12. p. 549-551.
- Clawson, Stephen H. and Douglas P. Tesner. "Sweeping the Med." **Surface Warfare** Feb 1982 v. 7. p. 14-18.
- Cockfield, D.W. "Breakout: A Key Role For the Naval Reserve." **US Naval Institute Proceedings** Oct 1985 v. 111. p. 52-58.
- Cogne, de Vaisseau Robert L. "French Hunt Mines." **US Naval Institute Proceedings** March 1988 v. 114. p. 108-112.
- Colucci, Frank. "Sea Dragners: The Airborne MCM (Mine Countermeasures) Force." **Sea Power** May 1983 v. 26. p.50-52+
- Combs, Amy E.C. "Surface Mine Warfare." **Surface Warfare** Jan-Feb 1987 v. 12. p. 19.
- "Command and Control for Mine Countermeasures." **Naval Forces** 1989 v. 10, no. 1. p. 72+
- "Composites Join the Fleet." **Engineering** (London, England) September 1989 v. 229. p. ACE10-11.
- "Computer Simulation Key to Mine-Clearing System." **Design News** October 23, 1995 v. 50[51]. p. 52.
- Connor, Steve. "How to Rid the Gulf of Mines." **New Scientist** August 20, 1987 v. 115. p. 26.
- "Cost Effective Coastal Minehunter." **Marine Engineering/Log** October 1986 v. 91. p. 43+
- Crane, R.H. "Mine Warfare History and Development." **Journal of Australian Naval Institute** Nov 1984 v. 10. p. 31-38.
- Crimmins, Jim. "Mine Warfare and Submarines." **US Naval Institute Proceedings** Oct 1994 v. 120, no. 10. p. 80-81.
- "Current Trends in Mine Warfare." **Naval Forces** (Supplement) 1984 v. 6. p. 38-39.

- Curtis, Ian. "Mines At Sea: Recognition At Last." **Defense & Foreign Affairs** July 1988 v. 16. p. 21-24.
- Dawson, Christopher. "Single-Role Minehunter For the Royal Navy." **International Defense Review** 1986 v. 19, no. 3. p. 305.
- Dawson, Christopher and Mark Hewish. "Mine Warfare -- New Ship Designs." **International Defense Review** Aug 1988 v. 21. p. 977-986.
- "Degaussing For MCMVs." **Naval Forces** 1989 v. 10, no. 1. p. 78+
- DeStefano, Robert. "The 27 Ship Navy: The Ultimate Mine Warfare Force?" **US Naval Institute Proceedings** Feb 1988 v. 114. p. 36-39.
- DeWilde, Josef. "Mine Warfare in the Gulf." **NATO's Sixteen Nations** 1992 v. 37, no. 1. p. 9-10+
- Dicker, R.J.L. "MIN (Mine Identification and Neutralization) --the Italian Navy's Mine Disposal Vehicle." **International Defense Review** 1990 v. 23, no. 3. p. 377-378.
- \_\_\_\_\_. "Mine Warfare Now and In the 1990's." **International Defense Review** 1986 v. 19, no. 3. p. 293-294.
- Dickey, Alan. "Kuwait May Buy UK's Mine-Hunting Robots." **The Engineer** (London, England) July 2, 1987 v. 265. p. 6.
- \_\_\_\_\_. "Scramble For Seabed Security." **The Engineer** (London, England) June 27, 1985 v. 260. p. 22-3.
- Dillion, David L. "Clear the (Suez) Canal." **Soldiers** June 1975 v. 30. p. 48.
- Dodd, Norman L. "Evolutionary Advances in Underwater Warfare." **Pacific Defence Reporter** April 1985 v. 11. p. 54.
- \_\_\_\_\_. "Mine Countermeasures At Sea." **Asian Defence Journal** April 1983 no. 4. p. 20-22+
- Donaldson, Thomas Q. "Meandering Mines." **US Naval Institute Proceedings** Sept 1984 v. 110. p. 137.
- Donohue, Hector. "Countering the Mine threat in the Asia-Pacific." **Asia-Pacific Defence Reporter** Sept-Oct 1995 v. 21, no. 12-13. p. 29-30+



- \_\_\_\_\_. "Mine Countermeasure Advances in the Asia Pacific." **Asia-Pacific Defence Reporter** Nov-Dec 1995 v. 21, no. 14-15. p. 23-24.
- Dunn, Michael C. "Fishing In Troubled Waters (The Significance of the Recent Mining of the Red Sea)." **Defense & Foreign Affairs** Oct 1984 v. 12. p. 16-19.
- Durwem, Simon. "'MAINS' -- The Latest Minehunting System." **Asian Defence Journal** March 1982 no. 3. p. 36+
- Duval-Destin, Marc and Michel Thomas. "Mine Clearance: A Key Factor in Resolving Future Crises." **Military Technology** Sept 1994 v. 18, no. 9. p. 62-65.
- Edwards, Rob. "Dervish Dances Through Killing Fields." **New Scientist** March 1996 v. 149. p. 25.
- Ennis, John. "Deep, Cheap & Deadly Mine Warfare: The Most Economical Weapon, and the Most Neglected." **Sea Power** Dec 1974 v. 17. p. 26-30.
- Farwell, Richard. "Sidescan Sonar--Low-Cost Solution to Today's Minesweeping Problems." **Sea Technology** Nov 1987 v. 28. p. 56.
- "FIMS--A Low-Cost Minehunting System." **Asian Defence Journal** June 1990 no. 6. p. 58-59.
- "First Netherlands-Built Tripartite Minehunter: HMS Alkmaar." **Marine Engineering/Log** October 1984 v. 89. p. 65.
- "First Picture of the Gorya Class Ocean-Going Minehunter." **Jane's Soviet International Review** Oct 1989 v. 1. p. 473.
- Fortin, Ernest. "Those Damn Mines." **US Naval Institute Proceedings** July 1992 v. 118, no. 7. p. 30-34.
- Fowler, Will. "Mine Warfare, Laying, Detecting and Neutralising." **Asian Defence Journal** Feb 1995 no. 2 p. 46+
- Foxwell, David. "MCM (Mine Countermeasures) Philosophies and Torpedo Defense Re-Defined." **International Defense Review** Sept 1992 v. 25, no. 9. p. 879-882+
- \_\_\_\_\_. "Mine Warfare In An Uncertain World: US Emphasizes Shallow-Water MCM (Mine-Countermeasures)." **International Defense Review** May 1992 v. 25, no. 5. p. 425-429.

- \_\_\_\_\_. "Naval Mine Warfare Unfunded and Underappreciated." **International Defense Review** Feb 1993 v. 26, no. 2. p. 125-129.
- \_\_\_\_\_. "New Technology Takes on the Sea Mine." **International Defense Review** Oct 1991 v. 24, no. 10. p. 1097-1099+
- \_\_\_\_\_. "Sea Mines and Minelaying." **International Defense Review Quarterly Report** 1996 no. 3. entire issue (16 p.).
- \_\_\_\_\_. "Sensor Triad Will Detect Buried Naval Mines." **International Defense Review** Dec 1991 v. 24, no. 12. p. 1359-1360.
- "French expertise in Mine Warfare." **Asian Defence Journal** Sept 1993 no. 9. p. 94+
- Friedman, Norman. "Postwar British Mine Countermeasures and National Strategy." **Warship** Jan 1987 v. 41. p. 43-51.
- \_\_\_\_\_. "US Mine-Countermeasures Programs." **International Defense Review** 1984 v. 17, no. 9. p. 1259+
- \_\_\_\_\_. "World Naval Developments." **US Naval Institute Proceedings** June 1988 v. 114. p. 119-120.
- Galatowitsch, Sheila. "Undersea Mines Grow Smarter and Deadlier." **Defense Electronics** March 1991 v. 23, no. 3. p. 57-58+
- Geisenheyner, Stefan. "Countermeasures Against Sea Mine Threats Show European Lead." **Defense Electronics** Apr 1980 v. 12. p. 43-44+
- \_\_\_\_\_. "Naval Warfare and the Sea Mine." **Asian Defence Journal** Aug 1984 no. 8. p. 12-14+
- \_\_\_\_\_. "Some Observations on Mine Warfare." **Asian Defence Journal** July-Aug 1980 no. 4. p. 72-74+
- "German MCMV Forces: The Arrival of a New Generation of Long Awaited Mine Countermeasures Vessels." **Military Technology** July 1988 v. 12. p. 28-29+
- Gillert, Doug. "Those Seagoing B-52s." **Airman** Jan 1989 v. 33. p. 29-33.
- Giusti, James R. "Sweeping the Gulf." **Surface Warfare** March-April 1988 v. 13. p. 2-5.
- Glenn, Christopher. "The Naval Electronics Gap." **Military Electronic/Countermeasures** March 1982 v. 8. p. 29-30+

Goodman, Glenn W., Jr. "Breaching Unseen Barriers: Offshore Mines Remain the Achilles' Heel of US Naval Expeditionary Forces." **Armed Forces Journal International** Nov 1995 v. 133, no. 4. p. 40-41.

Graham, David M. "Super SeaROVER Takes Role in U.S. Minesweeping Arena." **Sea Technology** March 1988 v. 29. p. 57-8.

Grazebrook, A. W. "Australia -- Mine Countermeasures Some Progress -- Some Problems." **Pacific Defence Reporter** Mar 1989 v. 15. p. 21-23.

\_\_\_\_\_. "Decision At Last On Mine Warfare (In Australia)." **Asia-Pacific Defence Reporter** Aug 1991 v. 18, no. 2. p. 25.

\_\_\_\_\_. "Further Delays For Inshore Minehunters." **Pacific Defence Reporter** Oct 1989 v. 16, no. 4. p. 14-15.

\_\_\_\_\_. "MCM (Mine Countermeasures) and the RAN (Royal Australian Navy)--A Frustrating Experience." **Naval Forces** 1992 v. 13, no. 2. p. 40-41+

\_\_\_\_\_. "Mine Countermeasures (in Australia)--Key Cross (Committee) Recommendations Rejected." **Pacific Defence Reporter** Apr 1990 v. 16, no. 10. p. 7-9.

\_\_\_\_\_. "Mines Surface With Gulf War." **Pacific Defence Reporter** Sept 1987 v. 14. p. 51+

\_\_\_\_\_. "Minesweepers for the RAN." **Pacific Defence Reporter** Oct 1983 v. 10. p. 49-50+

\_\_\_\_\_. "RAN (Royal Australian Navy) Reviews MCM (Mine Countermeasures) Plans." **Asia-Pacific Defence Reporter** Feb 1991 v. 17, no. 8. p. 20.

\_\_\_\_\_. "RAN's New Minesweepers Delayed Again." **Pacific Defence Reporter** July 1984 v. 11. p. 44.

"Great MCMV (Mine Countermeasures Vessels) Debate." **Military Technology** July 1992 v. 16, no. 7. p. 27-28+

Greeley, Brendan M., Jr. "Combined U.S. Forces Defeat Iranian Mine-Laying Mission." **Aviation Week & Space Technology** Sept 1987 v. 28. p. 32-33.

Greer, William L. and James Bartholomew. "The Psychology of Mine Warfare." **US Naval Institute Proceedings** Feb 1986 v. 112. p. 58-62.

Greville, P.J. "International Law Needed For Control of Mines." **Asia-Pacific Defence Reporter** Aug-Sept 1993 v. 20, no. 2-3 p. 40.

- Groning, H.W. "A New Concept in Mine Countermeasures." **Naval Forces** 1984 v. 5. p. 66-72.
- "Gulf of Suez: On Track With Courage." (Soviet Sailors Clear Mines at Southern Entrance of Suez Canal) **Soviet Military Review** Feb 1975 no. 2. p. 49-50.
- Hadden, Peter. "Mine Warfare--The Cinderella of Naval Weapons?" **Naval Forces** 1991 v. 12, no. 4. p. 40-42+
- Hamilton, Alfred T. "Clearing the Way: LANTFLT Mine Ops." **Surface Warfare** Sept 1981 v. 6. p. 28-31.
- Hansen, Richard. "Naval Minewarfare." **Turner Publishing Company**, Paducah, KY. 104 pp. (Call 502-443-0121).
- Harrison, Kirby. "Danger Below: Underwater Mines and Countermeasures." **Asia-Pacific Defense Forum** Spring 1984 v. 8. p. 35-39.
- Hastings, Scott A. "A Maritime Strategy for 2038." **US Naval Institute Proceedings** July 1988 v. 114. p. 30-35.
- Heine, Kenneth A. "Sweeping Ahead." **Surface Warfare** March-April 1988 v. 13. p. 6-9.
- Heffner, James A. "Athena-Class Research Ships: A Decade-Plus of Navy Service." **Sea Technology** March 1989 v. 30. p. 61-62.
- Heinl, Robert D., Jr. "Navy Can Learn From Suez Sweep." **Armed Forces Journal International** May 1974 v. 111. p. 7.
- Herteleer, W. "Mine Warfare in Peacekeeping Operations." **NATO's Sixteen Nations** 1994 v. 39, no. 1. p. 14-16.
- Hessman, James D. "In Search of 'The Weapon That Waits!'" **Sea Power** Pt. 1, Jul 1984 v. 27. p. 40-42; Pt 2, "Mine Warfare: A Two-Sided Game." Aug 1984 v. 27. p. 29-32.
- \_\_\_\_\_. "Lightening Under the Sea -- Magic Lantern: "Critically Needed" For Mine Detection." **Sea Power** Apr 1996 v. 39, no. 4. p. 93-94.
- \_\_\_\_\_. "Mine Warfare: A Sweeping Assessment." **Sea Power** Sept 1987 v. 30. p. 7-10.
- \_\_\_\_\_. "Mine Warfare: The Lessons Not Learned." **Sea Power** Pt. 1. Oct 1988 v. 31. p. 37-39; Pt. 2. "A Clear Path to Maritime Supremacy -- The Fiscal and Physical Dimensions of Mine Warfare." Nov 1988 v. 31. p. 36-40.
- Hessman, James D. and Vincent C. Thomas, Jr. "'Where the Warriors Are' ---Interview With Adm. Frank B. Kelso II, Commander in Chief, U.S. Atlantic Fleet." **Sea Power** Oct 1987 v. 30. p. 10+

- Hewish, Mark. "Remotely Operated Vehicles For Naval Mine Warfare." **International Defense Review** Apr 1989 v. 22. p. 441-445.
- Higman, Susan. "Boom Times Are Coming -- Avenger-Class MCMs Provide In-Depth Capabilities." **Sea Power** July 1988 v. 31. p. 39-40.
- Hoffmann, Roy F. "Offensive Mine Warfare: A Forgotten Strategy?" **US Naval Institute Proceedings** May 1977 v. 103. p. 142-155.
- Hohmann, Margitta. "Mine Hunting and Mine Avoidance Sonar: Why a Special Sonar?" **Naval Forces** 1995 v. 16, no. 5. p. 36-39.
- Holzer, Robert and Jason Glashow. "Staying on the Top of Mines." **Navy Times** Nov 28, 1994 v. 44. no. 8. p. 30.
- Horne, C.F. III. "New Role For Mine Warfare." **US Naval Institute Proceedings** Nov 1982 v. 108. p. 34-40.
- Hunt, Lee M. "In Stride." **U.S. Naval Institute Proceedings** Apr 1994 v. 120, no. 4. p. 59-62.
- Johnson, Thomas M. and Raymond T. Barrett. "Mining the Strait of Hormuz." **US Naval Institute Proceedings** Dec 1981 v. 107. p. 83-85.
- Jones, Mel R. "Closing the Mine Warfare Gap." **US Naval Institute Proceedings** Nov 1984 v. 110. p. 151-153.
- \_\_\_\_\_. "Mine Warfare Preparedness Begins Recovery After Years of Neglect." **Defense System Review** July-Aug 1984 v. 2. p. 37-39.
- Kandebo, Stanley W. "Kaman Offers Airborne Mine Detection to Navy." **Aviation Week & Space Technology** January 9, 1995 v. 142. p. 50-51.
- Keil, Robin. "Minehunting Sonar." **Naval Forces** 1994 v. 15, no. 6. p. 25-26.
- Keller, Kenneth. "MCM Avenger Class -- Learning the New Technology." **Surface Warfare** May-June 1987 v. 12. p. 14-15.
- Keller, Stephen H. "What Weapons That Wait? (Mine Warfare)." **US Naval Institute Proceedings** Oct 1994 v. 120, no. 10. p. 44-46.
- Kelso, Frank B., II. "Building Blocks of Naval Power." **US Naval Institute Proceedings** Nov 1992 v. 118, no. 11. p. 39-44.

- Key, William H., Jr. "Mine Countermeasures Can Be Assisted Cost-Effectively By Channel Conditioning Technique." **Defense Systems Review** 1985 v. 3, no. 6. p. 33-36.
- "Latest Mine Countermeasure Hovercraft Proposal: The SR-N4." **International Defense Review** Aug 1977 v. 10. p. 774-775.
- Lawson, Commo Max. "Tending the Mine Field: Sowing and Sweeping: The U.K. Is Working to Update Its Capabilities." **Journal of Defense & Diplomacy** Nov 1986 v. 4. p. 53-55.
- Layton, James Preston II. "Soviet Mine Barrier Warfare Capabilities in a Central Nuclear War." **Naval War College Review** July-Aug 1980 v. 33. p. 42-52.
- Leach, Henry. "The Channel Command: Jugular Vein of NATO." **NATO's Fifteen Nations** Oct-Nov 1978 v. 23. p. 38-40+
- Lenckus, Dave. "CAD/CAM System Pilots Wood Minesweeper Project." **Wood & Wood Products** March 1985 v. 90. p. 46+
- LeSueur Steve. "Snapshot of the Future (New Minehunting Technology)." **Navy Times** Nov 29, 1993 v. 43, no. 8. p. 40.
- Levie, Howard S. "Mine Warfare and International Law." **Naval War College Review** April 1972 v. 24. p. 27-35.
- Lobb, K. "Mine Countermeasures." **Naval Forces** (Special Supplement) 1984 v. 6. p. 35-37.
- \_\_\_\_\_. "Mine Countermeasures: New Trends in Operations and Tactical Planning." **Navy International** July 1984 v. 89. p. 421-424.
- Lok, Joris Janssen "Getting the Full Picture (Detect-Control-Engage Capability)." **Jane's Defence Weekly** June 10, 1995 v. 23, no. 23. p. 63-65+
- Longworth, Brian. "Mine Countermeasures." **Defence** Jan 1984 v. 15. p. 7-13.
- \_\_\_\_\_. "Solutions to the Shallow-Water Challenge." **Jane's Navy International** June 1996 v. 101. no. 5. p. 10-18.
- Luckow, Ulrik. "Victory Over Ignorance and Fear: The U.S. Minelaying Attack on North Vietnam." **Naval War College Review** Jan-Feb 1982 v. 35. p. 17-27.
- Mabesoone, Walter. "European Cooperation -- Naval Lessons From the Gulf War." **NATO's Sixteen Nations** (Special Issue: NATO 1949-1989 40 Years) 1989 v. 34. p. 67-68+

- Macbain, Merle. "Mines: The Forgotten Weapon." **Sea Power** May 1980 v. 23. p. 30-36.
- MacDonald, Scot. "The Naval Action at Mobile Bay." **Surface Warfare** May-June 1987 v. 12. p. 17-23.
- Manning, Harry. "Countering the Naval Mine Menace." **International Combat Arms** Nov 1988 v. 6. p. 42-47+
- Marriott, John. "Channel Command -- The Operational Forces." **NATO's Fifteen Nations** June-July 1973 v. 18. p. 28-38.
- \_\_\_\_\_. "Report on the Royal Navy Equipment Exhibition." **Armada International** Nov -Dec 1987 v. 11. p. 74-75.
- \_\_\_\_\_. "Survey of Modern Mine Warfare -- Mines and Mine Counter-Measures Currently Employed." **Armada International** Sept-Oct 1987 v. 11. p. 38-50.
- "Market for Mine Countermeasures Vessels." **Naval Forces** 1989 v. 10, no. 5. p. 87-90.
- Marsh, G.E. "The Royal Navy's New Minehunting Sonar 193M." **International Defense Review** Oct 1973 v. 6. p. 584-585.
- Martin, James M. and Bertrand P. Ramsay. "Sea Mines in Nicaragua." **US Naval Institute Proceedings** Sept 1990 v. 116, no. 9. p. 111-116.
- \_\_\_\_\_. "Seamines and the U. S. Navy." **Naval History** Summer 1989 v. 3. p. 44-48.
- \_\_\_\_\_. "Seamines and the U. S. Navy." **Naval History** Fall 1989 v. 3. p. 52-54.
- Marx, Stefan. "Baltic Mine Clearing Has Started." **Naval Forces** 1995 vo. 16, no. 4. p. 28.
- McCarthy, Dan B. "1975: Sailing the Suez Again." **Armed Forces Journal International** Feb 1975 v. 112. p. 26-27.
- McCauley, Brian. "Operation End Sweep." (Task Force 58 helicopters and minesweepers clear Haiphong Harbor) **US Naval Institute Proceedings** Mar 1974 v. 100. p. 18-25.
- McCoy, James M. "Mine Countermeasures: Who's Fooling Whom?" **US Naval Institute Proceedings** July 1975 v. 101. p. 39-43.
- McDonald, Wesley. "Mine Warfare: A Pillar of Maritime Strategy." **US Naval Institute Proceedings** Oct 1985 v. 111. p. 46-53.

- McFarlane, James. "Submersible Robots Extend Navigation, Mine Countermeasures Capabilities." **Defense Systems Review** Feb 1985 v. 3, no. 6. p. 23-25.
- "MCM Developments in FRG Navy." **Navy International** Apr 1984 v. 89. p. 212-215.
- "MCM (Mine Countermeasures) Product Survey." **Naval Forces** 1991 v. 12, no. 5. p. 62-65.
- "MCM Round Up." **Navy International** June 1988 v. 93. p. 305-307.
- Mecham, Michael. "Navy Deploys Helicopters to Counter Gulf Mine Threat." **Aviation Week & Space Technology** Aug 3, 1987 v. 127. p. 25-26.
- Miller, David. "Mine Countermeasures Marketplace Awash With Choices." **International Defense Review** Jan 1994 v. 27, no. 1. p. 44-50.
- "Mine Countermeasures." **Naval Forces** (Special Supplement) 1984 v. 6. p. 35-37.
- "Mine Countermeasures." **Navy International** June 1988 v. 93. p. 280-286.
- "Mine Countermeasures: Action Information Organization for MCMV." **Navy International** July 1984 v. 89. p. 404-410.
- "Mine Countermeasures and the Helicopter." **International Defense Review** Oct 1973 v. 6. p. 582-583.
- "Mine Countermeasures -- Command Systems Revolutionize Mine Warfare." **International Defense Review** (Naval Mine Warfare supp) Nov 1989 v. 22. p. 26-27.
- "Mine Countermeasures in the French Navy." **International Defense Review** Feb 1974 v. 7. p. 80-82.
- "Mine Countermeasures in the Persian Gulf--A German View." **Naval Forces** 1991. v. 12, no. 3. p. 59-60+
- "Mine Countermeasures -- MCMV (Mine-Countermeasures Vessels) Design and Trends." **International Defense Review** (Naval Mine Warfare supp) Nov 1989 v. 22. p. 13-20.
- "Mine Countermeasures -- Remotely Operated Vehicles." **International Defense Review** (Naval Mine Warfare supp) Nov 1989 v. 22. p. 28-33.
- "Mine Countermeasures -- Sonars: Still a Bright Future." **International Defense Review** (Naval Mine Warfare supp) Nov 1989 v. 22. p. 21-25.



- "Mine Countermeasures Vessels." **Marine Engineering/Log** December 1983 v. 88 p. 47.
- "Mine Menace and Countermeasures." **Maritime Defence** Apr 1989 v. 14. p. 98-125.
- "Mine Sonar For German MCMVs (Mine Countermeasures Vessels)." **Jane's Defence Weekly** Aug 24, 1991 v. 16, no. 8. p. 322.
- "Mine Types in Service." **Naval Forces** 1989 v. 10, no. 1. p. 82+
- "Mine Warfare and Countermeasures." **International Defense Review** Oct 1973 v. 6. p. 577-581.
- "Mine Warfare (1) -- The Lessons Of Two World Wars." **Defense Update International** Jan 1986 no. 67. p. 12-15+
- "Mine Warfare: The U.S. Navy Reacts." **Navy International** Jan 1985 v. 90. p. 35-38.
- "Mine Warfare: Threat and Counter Threat." **Navy International** Nov 1982 v. 87. p. 1422-1428.
- "Mine Warfare Today and Tomorrow." **Surface Warfare** Sept-Oct 1985 v. 10. p. 26-29.
- "Mine-Warfare Vessels and Systems." **International Defense Review** 1984 v. 17, no. 11. p. 1654-1662.
- "Minehunting For the 1990's." **Naval Forces** 1989 v. 10, no. 1. p. 63-66+
- "Minehunting Italian Style." **Marine Log** September 1988 v. 93. p. 61-3.
- "Mines and Mining." **Navy International** Feb 1986 v. 91. p. 106-111.
- "Minesweeper/Hunter Design." **Navy International** June 1988 v. 93. p. 288-298.
- "Minesweeping By Remote Control." **Marine Log** March 1988 v. 93. p. 35-6.
- Mobley, Richard A. "Intelligence support of the Mine Warfare Community." **Naval Intelligence Professionals Quarterly** Summer 1996 v. 12, no. 3. p. 1-2.
- "Modern Mine Programs From Upgrades to New Products." **International Defense Review** (Naval Mine Warfare supp) Nov 1989 v. 22., p. 6-7.
- Moorer, Thomas H. "Mine Warfare: Entering a New Era." **Wings of Gold** Fall 1984 v. 9. p. 7-8.

- Morison, Samuel L. "Norway: Its Mine Warfare Modernization Programme and Capabilities." **Naval Forces** 1996 v. 17, no. 1. p. 28-30.
- Mortimer, John. "Australian Mine Countermeasures Reflect Innovation, Flexibility." **Sea Technology** November 1989 v. 30. p. 18-19+
- "Naval Mine Warfare." **International Defense Review** (Naval Mine Warfare supp) Nov 1989 v. 22 entire issue.
- Nepean, Philip. "Naval Mine Countermeasures." **Armada International** March-April 1984 v. 8. p. 103-121.
- \_\_\_\_\_. "Sea Mines." **Armada International** Feb 1985 v. 9. p. 102-107.
- Norman, Stanley J. "Prepared For Mine Warfare?" **US Naval Institute Proceedings** Feb 1983 v. 109. p. 64-69.
- Osborne, Arthur M. "Air Defense for the Mining of Haiphong." **US Naval Institute Proceedings** Sept 1974 v. 100. p. 113-114.
- Padwick, Alan. "The Development and Present-Day Use of Mine Hunting Sonars." **Military Technology** March 1987 v. 11. p. 66-73.
- Paloczi-Horvath, George. "Hunt Ship Scheme Kicks Off." **The Engineer** (London, England) Nov 3, 1994 v. 279. p. 6.
- Patterson, Andrew, Jr. "Mining: A Naval Strategy." **Naval War College Review** May 1971 v. 23. p. 52-66.
- Patton, James H., Jr. "ASW: Winning the Race." **US Naval Institute Proceedings** June 1988 v. 114. p. 63-66.
- Pengelley, R.B. "Clearing the Suez Canal." **International Defense Review** Dec 1974 v. 7. p. 735-736.
- \_\_\_\_\_. "New MCM (Mine-Countermeasures) Vehicles for Royal Navy." **International Defense Review** July 1988 v. 21. p. 824.
- Phillip, John S. "Sea Mines: A Stealth Weapon." **Asian Defence Journal** Sept 1981 no. 9. p. 83+
- Pochhacker, Christian. "Minehunters of the Red Sea." **Defense Update International** 1985 no. 64. p. 30-33.

- \_\_\_\_\_. "Troika System: Remote Control Minesweeping." **Defense Update International** Aug 1986 no. 74. p. 42-45.
- Pollitt, George W. "MCM Computer for MSOs." **Surface Warfare** Feb 1982 v. 7. p. 20-21.
- Polmar, Norman. "The U.S. Navy: Mine Countermeasures." **US Naval Institute Proceedings** Feb 1979 v. 105. p. 117-119.
- "Portable Magnets Save Ships." **The Engineer** (London, England) June 7, 1990 v. 270. p. 34-5.
- Preston, Anthony. "Allied MCM (Mine Countermeasures) in the Gulf (Special Supplement)." **Naval Forces** 1991 v. 12, no. 4. p. 47-48+
- \_\_\_\_\_. "Deep Mine Warfare." **Naval Forces** 1989 v. 10, no. 3. p. 47-48+
- \_\_\_\_\_. "Intelligent Slaves: The Growing Importance of ROVs (Remotely Operated Vehicles) In Mine Warfare." **Naval Forces** 1993 v. 14, no. 1 p. 51+
- \_\_\_\_\_. "Mine Countermeasures For Asian and Pacific Navies." **Asian Defence Journal** Apr 1991 no. 4. p. 48+
- \_\_\_\_\_. "Mine Warfare in the 1990s." **Asian Defence Journal** May 1993 no. 5. p. 48+
- \_\_\_\_\_. "Minehunters and Minehunting." **Asian Defence Journal** Sept 1993 no. 9. p. 84-86+
- \_\_\_\_\_. "The Infernal Machine: Mines and Countermeasures." **Defence** Aug 1988 v. 19. p. 559-566.
- Prina, L. Edgar. "Deep Threat: The Navy Is Flunking Higher on Mine Warfare." **Sea Power** May 1983 v. 26. p. 41-48.
- \_\_\_\_\_. "No Exit, No Entry: U.S. and NATO Mine Warfare Capabilities Are Improving ... But Not Fast Enough!" **Sea Power** Feb 1986 v. 29. p. 6-12.
- Proctor, Barry and Marianne Nutting. "Mine Countermeasure Support Platform Conversion Ship Design." **Marine Technology** July 1994 v. 31. p. 201-214.
- "Radio-Controlled Drone Boats Used in Vietnam Minesweeping." **US Naval Institute Proceedings** Feb 1970 v. 96. p. 123-124.
- Raimondo, Natale. "Equipping Mine Countermeasures Ships for Channel Conditioning." **Sea Technology** April 1987 v. 28. p. 24-8.

- Resing, David C. "Mine Countermeasures In Coastal Harbors: A Force Planner's Dilemma." **Naval War College Review** Spring 1987 v. 40. p. 53-62.
- Robins, Yves. "Weapon System Series: The Tripartite Minehunter Program." **NATO's Fifteen Nations** Oct-Nov 1979 v. 24. p. 80-82+
- Robinson, John G. "Miners Served Here." **Surface Warfare** Aug 1980 v. 5. p. 26-29.
- Robinson, Richard. "Mine Countermeasures: How Much Is Enough?" **Defense Systems Review** Feb 1985 v. 3, no. 6. p. 37-40.
- Rodholm, I.B. "Advances In Mine Warfare." **Naval Forces** 1990 v. 11, no. 6. p. 49-53.
- Rogers, Edward J. "Mines Wait But We Can't!" **US Naval Institute Proceedings** Aug 1982 v. 108. p. 51-54.
- Rouarch, Claude. "A New Minehunter for the Swedish Navy." **International Defense Review** 1984 v. 17, no. 9. p. 1277-1279.
- \_\_\_\_\_. "The Naval Mine -- As Effective a Weapon As Ever." **International Defense Review** 1984 v. 17, no. 9. p. 1239-1240+
- Ruth, Michael S. "COOP: The Breakout Gang." **Surface Warfare** July-Aug 1984 v. 9. p. 19-20.
- Salitter, Michael and Ulrich Weisser. "Shallow Water Warfare in Northern Europe." **US Naval Institute Proceedings** March 1977 v. 103. p. 36-45.
- Savage, Don. "Crew Goes Miles at Own Expense to Service On Ship --Ocean-Going Minesweeper Attracts Reservists." **Officer** Oct 1987 v. 63. p. 20-22.
- Schemmer, Benjamin F. "Navy Likely to Renew Last Year's Unsuccessful Bid For 46 New MH-53Es." **Armed Forces Journal International** June 1980 v. 117. p. 16+
- Schlim, A.J.P. "Mine Warfare in European Waters." **NATO's Sixteen Nations** Feb-March 1986 v. 31. p. 20-22+
- \_\_\_\_\_. "Mine Warfare in the North Sea -- The Weak Link." **NATO's Sixteen Nations** (Special Issue I) April-May 1984 v. 29. p. 20-22.
- Schlimm, Andre. "The Belgian Navy and Mine Countermeasures in the Channel." **NATO's Fifteen Nations** (Special Issue) 1982 no. 2 p. 28-30.

- Schreadley, R.L. "The Mine Force: Where the Fleet's Going, It's Been." **US Naval Institute Proceedings** Sept 1974 v.100. p. 26-31.
- "Sea Eagle and Pluto -- Mine-Disposal Submersibles From Sweden and Italy." **International Defense Review** 1984 v. 17, no. 4. p. 500.
- Searight, Murland W. "Prepare to Sweep Mines (in Gulf of Tonkin, Jan 1968)." **US Naval Institute Proceedings** Jan 1970 v. 96. p. 54-59.
- Shchedrov, I. "Feat (of Clearing the Harbor) at Chittagong (Bangladesh)." **Soviet Military Review** Nov 1974 no. 11. p. 42-43.
- Shelley, Marke R. "A Better Game of Dodge'n Detonate." **US Naval Institute Proceedings** Feb 1988 v. 114. p. 41-43.
- Sherman, Robert J. "Mine hunting--First Line of ASW defense?" **Sea Technology** Nov 1986 v. 27. p. 31+
- "Shock Tests Conducted on Surface Effect Ship." **Sea Technology** May 1986 v. 27. p. 21.
- Shreadley, R.L. "The Mine Force -- Where the Fleet's Going, It's Been." **US Naval Institute Proceedings** Sept 1974 v. 100. p. 26-31.
- Simmons, Edwin H. "Mining at Wonsan -- and the Persian Gulf." **Fortitudine** Summer 1987 v. 17. p. 3-7.
- Skripsky, Alan J. "Handling the Magnetic Force: USS Peleliu Depermed." **Surface Warfare** July 1982 v. 7. p. 7-9.
- Smith, Robert H. "Mine Warfare: Promises Deferred." **US Naval Institute Proceedings** April 1980 v. 106. p. 26-33.
- Spooner, G.K. "Minewarfare -- Policy or Palsy?" **RUSI Journal for Defence Studies** March 1978 v. 123. p. 52-57.
- Starr, Barbara. "A Joint Approach to the Hidden Threat." **Jane's Defence Weekly** Feb. 14, 1996. v. 25, no. 7. p. 20+
- Starr, Barbara et al. "Multi-Role is Key to Smaller Air Wings (Size and Scope of U.S. Navy Carrier Aviation Is Being Rethought)." **Jane's Defence Weekly** Apr 3, 1993 v. 19 no. 14. p. 29-35.
- Staveley, William. "NATO's Defense Against Mines." **Naval Forces** 1984 v. 5. p. 14-21.

- Steiner, Walter K. "Norsemen of the Navy." **Officer** Jan 1987 v. 63. p. 19-22.
- Stillwell, Paul. "SS Bridgeton: The First Convoy." Interview with CAPT Frank C. Seitz, Jr. **US Naval Institute Proceedings** May 1988 v. 114. p. 52-57.
- Stone, Norman L. "Ocean Control: Soviets on Mine Warfare -- Does U.S. Fleet Measure Up?" **Military Electronic/Countermeasures** May 1980 v. 6. p. 58-60+
- Swarztrauber, S.A. "River Patrol Relearned." **US Naval Institute Proceedings** May 1970 v. 96. p. 120-157.
- "Sweeping the Suez: Delicate project (Nimbus Star/Nimbus Moon) Calls For Lots of Fast Talk." **Air Force Times** June 26, 1974 v. 34. p. 33.
- Tarpey, John F. "A Minestruck Navy Forgets Its History." **US Naval Institute Proceedings** Feb 1988 v. 114. p. 44-47.
- Taylor, Jeremy D. "Mining: 'A Well Reasoned and Circumspect Defense'." **US Naval Institute Proceedings** Nov 1977 v. 103. p. 40-45.
- "The 'Smart' Mine (MOBILE Water Mine [MOWAM])" **Armed Forces Journal International** Feb 1981 v. 118. p. 25.
- "The U.S. Navy's MCMVs: Wood and Glass Reinforced Plastic Construction." **Maritime Defence** May 1984 v. 9. p. 159-161.
- Thomas, Vincent C., Jr. "Equipment Capabilities, and the Human Element." **Sea Power** Mar 1992 v. 35, no. 3. p. 8-10+
- Tierney, Larry and Richard Funk. "The Tools of the Minehunting Trade." **Sea Technology** Nov 1985 v. 26. p. 47-50.
- Toremans, Guy A.H. "Navies Get the MOST (Mine Countermeasures Vessel (MCMV) Operational Sea Training) From MCM (Mine Countermeasures) Training." **Jane's Defence Weekly** Nov 11, 1995 v. 24, no. 19. p. 28-30.
- Tornberg, Claes. "Sweden Rethinks Its Strategy." **US Naval Institute Proceedings** Mar 1990 v. 116, no. 3. p. 80-84.
- "Tough Battle Starts Over Navy's Robot." **The Engineer** (London, England) April 2, 1987 v. 264. p. 11.

- Townley, Mark. "Command and Control in Mine Countermeasures." **Naval Forces** 1990 v. 11, no. 4. p. 38-39+
- "Troika Mine Sweeping Systems." **Journal of Defense & Diplomacy** Aug 1987 v. 5. p. 41-43.
- Truver, Scott. C. "Airborne Mine Countermeasures in the US Navy's Front Line." **International Defense Review** 1987 v. 20, no. 10. p. 1353-1355.
- \_\_\_\_\_. "Exploding the Mine Warfare Myth." **US Naval Institute Proceedings** Oct 1994 v. 120, no. 10. p. 36-43.
- \_\_\_\_\_. "Mines of August : An International Whodunit." **US Naval Institute Proceedings** May 1985 v. 111. p. 94-117.
- \_\_\_\_\_. "Naval Mine Countermeasures--Lagging Behind the Threat?" **International Defense Review** Sept 1995 v. 28, no. 9. p. 54-55+
- \_\_\_\_\_. "Tomorrow's Fleet." **US Naval Institute Proceedings** May 1989 v. 115. p. 302-317.
- \_\_\_\_\_. "Weapons That Wait ... and Wait ...." **US Naval Institute Proceedings** Feb 1988 v. 114. p. 31-40.
- Truver, Scott C. and Jonathan S. Thompson. "Navy Mine Countermeasures: Quo Vadis?" **Armed Forces Journal International** April 1987 v. 124. p. 70-74.
- Turbe, Gerard. "BAMO -- The French Mine-Countermeasures Vessel." **International Defense Review** 1987 v. 20, no. 10. p. 1361-1362.
- "Two New French Sonars: Ibis and Eledone." **International Defense Review** April 1977 v. 10. p. 300.
- "U.S. (in) Mid-East (Combined) Military Operation (Clearing the Suez Canal)." (Operation Nimbus Star). **Armed Forces Journal International** May 1974 v. 111. p. 22.
- "Underwater Robots Go It Alone." **The Engineer** (London, England) September 24, 1987 v. 265. p. 58.
- Van Kuffeler, F. deBlocq. "The Tripartite Minehunter -- A Model for International Cooperation?" **International Defense Review** 1978 v.11, no. 9. p. 1472-1476.
- Van Nortwick, John. "Endsweep." **Marine Corps Gazette** May 1974 v. 58. p. 29-36.

- Veth, K.L. "Shootout at Palembang: The 'Hellbirds' Mine the Moesi River." **American Aviation History Society Journal** Spring 1980 v. 25. p. 72-74.
- Walker, Robin A. "STANAVFORCHAN (Standing Naval Force Channel) : An Effective MCM (Mine Countermeasures) Squadron." **Armed Forces Journal International** Mar 1986 v. 5. p. 135-136.
- Walsh, Don. ROV's of the Sea." **Sea Power** July 1984 v. 27. p. 25-32.
- Walsh, Edward J. "Navy Adopts New Doctrine, New Technologies to Address Changing Mine Countermeasures." **Defense Electronics** July 1992 v. 24, no. 7. p. 40-42+
- \_\_\_\_\_. "Navy and Marines Focus on Achilles' Heel: Shallow-Water Mines." **Armed Forces Journal International** Aug 1993 v. 131, no. 1. p. 35-38.
- \_\_\_\_\_. "Navy Struggles to Manage Mine Warfare Shipbuilding." **Armed Forces Journal International** Mar 1991 v. 128, no. 8. p. 48+
- \_\_\_\_\_. "Riding the Wild Surf: Sea Services Zero in On Shallow-Water Mines." **Armed Forces Journal International** July 1994 v. 131, no. 12. p. 40-42.
- Walters, Brian. "Lidars (Laser-Based Light Detection and Ranging) to Probe the Sea From the Air." **Armada International** April-May 1995 v. 19, no. 2. p. 44-46+
- \_\_\_\_\_. "Mines -- A Neglected Aspect of Underwater Warfare." **Asian Defence Journal** June 1987 no. 6. p. 76-78+
- \_\_\_\_\_. "ROVs: An Integral Part of MCM." **Navy International** June 1988 v. 93. p. 299-304.
- Ward, Don. "Mine Boggling (After Desert Storm Changes For Mine Warfare)." **Navy Times** June 28, 1993 v. 42, no. 38. p. 12-14.
- Warner, John. "Any Ship Can Be a Minesweeper -- Once!" **Officer** (ROA National Security Report supp opposite p 22) Oct 1987 v. 63. p. 10-11.
- Watts, Anthony J. "Naval Forces' Mine of Potential." **Jane's Defence Weekly** May 13, 1995 v. 23, no. 19. p. 23-24.
- Watts, Tony. "Beware the Enemy Below (Mines and Submarines)." **Jane's Defence Weekly** May 7, 1994 v. 21, no. 18. p. 28-29.
- Wettern, Desmond. "Coping With 'The Hidden Threat'--The Neglected Art of Mine Warfare." **Sea Power** Mar 1991 v. 34, no. 3. p. 36-40.



- \_\_\_\_\_. "Light Naval Forces." **Defense & Diplomacy** May 1990 v. 8 no. 5. p. 29-30.
- \_\_\_\_\_. "Mine Countermeasures: Forgotten Lessons." **Defense & Diplomacy** Nov 1988 v. 6. p. 18-21.
- \_\_\_\_\_. "Mine Countermeasures: Sounding On a Growth Industry." **Military Technology** Feb 1991 v. 15, no. 2. p. 41-42+
- \_\_\_\_\_. "Mine Warfare: Still the Forgotten Factor." **Sea Power** Oct 1989 v. 32. p. 58+
- \_\_\_\_\_. "Receiving End -- European NATO Builds Up Its Mine Warfare Forces." **Sea Power** Oct 1988 v. 31. p. 42-45.
- \_\_\_\_\_. "RN's Major Mine Warfare Boost." **Pacific Defence Reporter** July 1985 v. 12. p. 37-38.
- \_\_\_\_\_. "The Alliance Deals With An Explosive Situation -- NATO Finally gets Serious About Mine Warfare." **Sea Power** Oct 1985 v. 28. p. 73+
- \_\_\_\_\_. "Unofficial Navy Add-Ons Worked Well (In Gulf War)." **Asia-Pacific Defence Reporter** May 1991 v.17, no. 11. p. 12-13.
- Whalen, John F. "The Ghost of Rebel Torpedoes." **US Naval Institute Proceedings** Sept 1996 v. 122. p. 58-63.
- Wheland, Mathew J. "Soviet Mine Warfare: Intent and Capability." **US Naval Institute Proceedings** Sept 1980 v. 106. p. 109-114.
- White, Carl. "Move and Countermove: Belated Recognition for Naval Mine Warfare and Mine Countermeasures Requirements." **Sea Power** June 1985 p. 12+
- Wile, Ted S. "(Soviet Union) Their Mine Warfare Capability." **US Naval Institute Proceedings** Oct 1982 v. 108. p. 145-151.
- Wilhelm, Charles E. "Forward...From the Sea: The Mine Warfare Implications." **Marine Corps Gazette** July 1995 v. 79, no. 7. p. 23-26.
- Wilson, Geroge C. "Navy is Ready to Clear Mines From Harbors of North Vietnam." **US Naval Institute Proceedings** March 1973 v. 99. p. 122-123.
- Witt, Mike. "Countering the Sea Mine." **Asian Defence Journal** Oct 1988 no. 10. p. 66+
- \_\_\_\_\_. "Finding the Sea Mine." **Asian Defence Journal** Feb 1993 no. 2. p. 39+

- \_\_\_\_\_. "Mine Countermeasures--Technology's Role." **Asian Defence Journal** Oct 1990 no. 10. p. 36+
- Wood, Colin G. "MAINS (Minehunting Action Information and Navigation System) -- Vital Adjunct to Mine Warfare." **Armada International** March-April 1984 v. 8. p. 126+
- \_\_\_\_\_. "Underwater Mines and Mine Countermeasures." **Armada International** Dec 1988/Jan 1989 v. 12. p. 42-43+
- Wight, C.C. "Origins of the 'Bird' Class Minesweeper Design." Appendix to Harry C. Armstrong, "The Removal of the North Sea Mine Barrage." **Warship International** June 1988 v. 25. p. 163-167.
- Wyatt, Keith. "Minesweeping For the Many: The 'Craft of Opportunity' Concept." **Sea Technology** October 1987 v. 28. p. 41-45.
- Yarovoi, G. "Antimine Defence." **Soviet Military Review** Sept 1974 no. 9. p. 24-25.
- Young, P. Lewis. "ADI's AMASS (Australian Defence Industries Minesweeping and Surveillance System)." **Asian Defence Journal** Jan 1996 no. 1. p. 25.
- \_\_\_\_\_. "Australia's Search For a New Coastal Mine Countermeasures Vessel." **Asian Defence Journal** Sept 1993 no. 9. p. 78-80+
- \_\_\_\_\_. "Mine Countermeasures: A Survey of Systems and Vessels in Service." **Asian Defence Journal** Nov 1984 no. 11. p. 74-76+
- \_\_\_\_\_. "Mining the Straits of Southeast Asia." **Jane's Intelligence Review** Feb 1996 v. 8, no. 2. p. 91-94.
- \_\_\_\_\_. "Royal Australian Navy's Mine Hunter Project." **Asian Defence Journal** Oct 1992 no. 10 p. 55+
- Young, Thomas-Durell. "Australian Navy's Catamaran Minehunter." **International Defense Review** 1986 v. 19, no. 3. p. 300-301.
- Zakhartchenko, Alexander Sergeevitch et al. "Russian Naval Mines Development." **Naval Forces** 1994 v. 15, no. 5. p. 26-27.

# TECHNICAL REPORTS

Ahn, S.W. **Neutralization of Surf Region Mines.** Trident scholar project rept.: Naval Academy, Annapolis, MD: 9 May 95. 124p.

*ABSTRACT: There is significant military interest in the dynamic behavior of a net array of circular cylinders traveling through a fluid medium. Although research has been conducted on a towed single line configuration in water, there is little information regarding the dynamic behavior of a towed net configuration. This investigation examined the effect that physical geometry, tow velocity, and tow angle-of-attack had on the lift and drag acting on a net towed in water. The measurements indicate a significant relationship between these factors and the stability of the net, and also provide normalized polynomial equations which will be useful in predicting the aero-ballistics of the net.*

ACCESSION NUMBER: ADA299408

Alexander, L. et al. **Q-Route Survey Demonstration Project Operational Assessment.** Final rept. Coast Guard Research and Development Center, Groton, CT: Jun 90. 119p.

*ABSTRACT: The Q-Route survey mission involves exploratory ocean floor reconnaissance and the location/relocation of mine-like objects along established routes from the entrance of major U.S. ports to the continental shelf. This report presents results of a joint U.S. Coast Guard - U.S. Navy Q-Route Survey project conducted in New London, CT. USCG vessels were equipped with commercially-available equipment and systems, and manned by a mix of USCG and USN personnel. Results of at-sea operational evaluations intended to measure the effectiveness of an integrated navigation/data management system in meeting Q-route survey mission requirements are discussed. An integrated system configuration comprised of side scan sonar, display/data management, and navigation/positioning subsystem was found to be highly effective for conducting detailed Q-route surveys. USCG vessels are suitable platforms from which to conduct coastal Q-route survey operations. No significant vessel-related constraints were associated with available working space, minimum vessel speed, or electrical power. A joint-service approach to Q-route survey operations effectively uses existing skills and talent. With only minimum training assigned USN personnel operated the equipment consoles while USCG personnel piloted the vessel and deployed/recovered the side scan sonar and acoustic tracker hydrophone. The most critical factor impacting the effective conduct of route survey operations was the availability and performance of the radio navigation system. During these trials Differential Loran-C provided a predictable, geodetic accuracy of 23 meters, 2 DRMS.*

ACCESSION NUMBER: ADA230638

Anderson, B. and G. Campanella. **Development of a Maneuvering Model for the RAN Precursor Mine Sweeping Drone Boat.** Technical rept. Materials Research Labs., Ascot Vale (Australia).: Jan 94. 27p.

*ABSTRACT: A three-degree-of-freedom mathematical model has been developed to describe the zigzag maneuvering behavior of a prototype hull form used in the Royal Australian Navy precursor mine sweeping drone boat. The model predicts the yaw rate of the vessel in response to the angle of thrust that a single outboard motor makes with respect to the center line of the boat. The outboard motor is assumed to supply a constant thrust. This report describes the development of the model from first principles and its transformation into a form suitable for use in closed loop control modeling. The coefficients of the model were determined using full scale maneuvering data for the prototype hull form.*

ACCESSION NUMBER: ADA279249

Anderson, L.B. and E.L. Schwartz. **Net Assessment Methodologies and Critical Data Elements for Strategic and Theater Force Comparisons for Total Force Capability Assessment (TFCA)**. Volume III. A Preliminary Documentation of a Naval Model. Interim rept. no. 2. Institute for Defense Analyses, Alexandria, VA. International Security Assessment Div. : Jan 82. 338p.

*ABSTRACT: The model described in this paper is an aggregated, fully automated, deterministic model of combat between two opposing forces. The Blue forces in this model can consist of aircraft carriers, escort ships, submarines, sea-based attack and defensive aircraft, and land-based defensive aircraft. The Red forces in the model can consist of surface ships, submarines, land-based attack and defensive aircraft, and ground defenses. The model is designed to simulate combat between these forces in areas in which geography can play a significant role, such as in the Mediterranean area. In particular, a goal in the design of this model was to include geographical considerations in an aggregated model--not to build a model that simulates either combat or geography (or both) in great detail. The description of the model in this paper is preliminary only in that portions of this description will be expanded in the near future in order to more thoroughly document in the model. The current status of the model is as follows: Its programming is complete. That is, an input routine, the combat interaction routines, the output routines, and the code to hold these routines together have been programmed. An unclassified and entirely hypothetical data base has been prepared, the model has been successfully run with this data base, and brief initial tests of the model have been completed.*

ACCESSION NUMBER: ADA123614

Autry, D. and D.G. Norton. **Increasing Maritime Role of the U.S. Air Force**. Research rept. Air War Coll., Maxwell AFB, AL.: May 89. 67p.

*ABSTRACT: This paper briefly reviews the history of recent Air Force participation in maritime operations and support of the U.S. maritime strategy. It analyses Air Force capabilities in antisurface warfare, mine warfare, antiair warfare, and maritime aerial refueling. Improvements in these capabilities are suggested. The paper concludes that Air Force aircraft have a significant role in U.S. maritime operations. However, JCS force planner and theater commanders must carefully plan how to use these scarce resources to best advantage.*

ACCESSION NUMBER: ADA217654

Ball, J.F. **Effects of Sea Mining Upon Amphibious Warfare**. Master's thesis Aug 91-Jun 92. Army Command and General Staff Coll., Fort Leavenworth, KS.: 5 Jun 92. 148p.

*ABSTRACT: This study investigates the effects of sea mining upon amphibious warfare. The methodology involves case studies of amphibious assaults conducted at Gallipoli Normandy, Wonsan, and the Persian Gulf during Operation Desert Storm. The cases are examined in terms of forces involved, mining conducted, and the effect the mining and mine countermeasures had upon the achievement of surprise in the assault. The study attempts to determine if the determining factor is the level of mine technology, or the size of the forces involved. It emphasizes the importance of rapid and complete mine countermeasures to the achievement of surprise in the amphibious assault. Based upon the four cases studied, the determinant appears to be force levels. At Normandy where levels were adequate, the operation was successful. At Gallipoli and Wonsan the results were either failure or inconclusive. The Persian Gulf study points out that failure would have been the likely result. A recommendation to prevent further deterioration of the mine countermeasures force is presented.*

ACCESSION NUMBER: ADA255564

**Bennett, R.H. Seabed-Structure Interaction: Workshop Report and Recommendations for Future Research Held in Metairie, Louisiana on 5-6 November 1991.** Final rept. Naval Oceanographic and Atmospheric Research Lab., Stennis Space Center, MS.: Feb 92. 28p.

*ABSTRACT: Intrinsic to the topic of Seabed-Structure Interaction (S-SI) of objects coupled with the seafloor is the dynamics of the 'system.' The dynamics involve environmental forcing of the object and the seabed, the fundamental properties of the geological material, the size and shape of the object, and the time-dependent processes associated with the coupling of the water column, seabed, and the object. Thus, the most crucial S-SI research problems to address in the Coastal Benthic Boundary Layer Special Research Project (SRP) should focus on the dynamics and time-dependent processes affecting objects coupled to the sea floor. The research efforts should include a range of scales from micro to macro but largely focused on the dynamics and processes in proximity to the object rather than broad scale geological oceanographic processes. Much is to be gained by interdisciplinary research well focused on specific S-SI phenomena. Acoustics, Sediments, Mines.*

ACCESSION NUMBER: ADA250692

**Berger, H.K. Mine Deployment and Operational Means.** Naval Intelligence Support Center, Washington, DC. Translation Div.: 25 Apr 83. 10p. [Trans. of Soldat und Technik (Germany, F.R.), D 6323 E, v2 p68-71 Feb 83.]

*ABSTRACT: No abstract available.*

ACCESSION NUMBER: ADA129041

**Blair, D.G. Array Design: Literature Survey For A High-Resolution Imaging Sonar System. Pt 1.** Technical note. Materials Research Labs., Ascot Vale (Australia): Dec 93. 37p.

*ABSTRACT: This report, together with the proposed Part 2, surveys the literature relevant to the design of a sonar array for imaging mines with a resolution approaching 1 mm. Written as a descriptive and sometimes critical review, the report draws out the connections to mine imaging. Background areas surveyed include acoustic propagation and scattering, signal processing and display. The theory of array beamforming is traced, beginning from basics and including the near field and broadband signals. Three-dimensional beamforming, by the delay-and-add method and by backpropagation (numerical holography), are discussed. Working systems and related development work are described, including sonar systems, high-resolution underwater imaging, imaging in medicine and nondestructive evaluation, synthetic aperture, acoustic holography and tomography.*

ACCESSION NUMBER: ADA277070

**Blood, C.G. Analyses of Battle Casualties by Weapon Type Aboard U.S. Navy Warships. (Reannouncement with New Availability Information).** Final rept. Naval Health Research Center, San Diego, CA: Feb 91. 9p.

*ABSTRACT: The number of casualties was determined for 513 incidents involving U.S. Navy warships sunk or damaged during World War II. Ship type and weapon were significant factors in determining the numbers of wounded and killed. Multiple weapon attacks and kamikazes yielded more wounded in action than other weapon types. Multiple weapons and torpedoes resulted in a higher incidence of killed in action than other weapons. Penetrating wounds and burns were the most prominent injury types. Kamikaze attacks yielded significantly more burns than incidents involving bombs, gunfire, torpedoes, mines, and multiple weapons. Mine explosions were responsible for more strains, sprains, and dislocations than the other weapon types.*

ACCESSION NUMBER: ADA259268

**Boboltz, D.A. USS AVENGER (MCM 1) Standardization, Locked Shaft, and Trailed Shaft Trials.** Final rept. Naval Surface Warfare Center Carderock Div., Bethesda, MD. Ship Hydromechanics Dept: May 92. 77p.

*ABSTRACT: Standardization, Trailed Shaft, and Locked Shaft Trials were conducted on USS AVENGER (MCM 1) to develop baseline speed and powering characteristics for the MCM 1 class minesweepers. The trials were performed off the west coast of St. Croix, U.S. Virgin Islands from 19 to 22 June 1989 as part of NAVSEA First of Class Performance Trials. During the Standardization Trial a maximum speed of 13.92 kn at 181.7 r/min average shaft speed was achieved with the propellers at nominal 100% of design pitch. To achieve this speed, AVENGER required 2,050 total shaft horsepower (1,530 kW), with 59,300 ft-lbf total torque (80,300 N-m) applied to the shafts. The maximum speed achieved during the Locked Shaft Trial was 9.13 kn with the port shaft driving the ship at a shaft speed of 167.2 r/min. At this speed the AVENGER used 970 hp (720 kW) and 30,400 ft-lbf of torque (41,200 N-m) on the driving shaft. During the Locked Shaft Trial, the pitch on the port propeller was at nominal 100%, while the pitch on the locked starboard shaft propeller was nominal 15%. For the Trailed Shaft Trial a maximum speed of 10.34 kn was achieved at 168.5 r/min shaft speed on the driving port shaft. This speed was accomplished with 980 hp (730 kW) and 30,300 ft-lbf torque (41,100 N-m) on the driving shaft. During the Trailed Shaft Trial nominal 100% pitch was used on the port propeller with the starboard propeller trailing at nominal 10% pitch. Baseline standardization, trailed shaft, and locked shaft curves are also developed for the AVENGER in this report.*

ACCESSION NUMBER: ADA253966

**Boerman, D.A. Finding an Optimal Path Through a Mapped Minefield.** Master's thesis 1 Jan 92-24 Mar 94. Naval Postgraduate School, Monterey, CA: Mar 94. 55p.

*ABSTRACT: An integer programming model is developed to find an optimal path through a naval minefield which has been completely mapped. The region of the minefield is discretized into a grid network and a network flow model with side constraints is created to minimize the sum of a weighted combination of risk and distance along any path through the minefield. Tests are conducted on a 20x20 grid with a field of 10 mines. This generates a model with 1470 variables and 818 constraints which is solved on an 80386 33 MHZ PC in 405 seconds. Tests are run for various weights and to test the effects of shifting the grid in space. Results show that varying the weight yields paths with sensible tradeoffs between distance and risk, and show that improved paths can be obtained by shifting the network grid. The model developed provides users with a means to plan a covert penetration of a minefield using the potential intelligence gathering capabilities of an autonomous underwater vehicle.*

ACCESSION NUMBER: ADA281012

**Bradley, S.C. Clearing the Vital Choke Points in the Sea Lines of Communication-Its not just a Navy Problem and Solution.** Final rept. Naval War Coll., Newport, RI. Dept. of Operations: 17 May 93. 32p.

*ABSTRACT: This paper is primarily a thought process. Many scholarly works and group efforts have pointed clearly to the abysmal condition of the United States Naval Mine Countermeasures (MCM) both in capability and size. The problems which the U S Navy has in this capability stem from two reasons: first, an historic lack of effort in funding a robust MCM capability, and second, there are limitations in the laws of physics which make detection of mines a difficult process. The purpose of this paper is not to split the arrow which has already landed in the center of the Navy's MCM forces, but to stimulate the reader to not view MCM as the Navy problem. There are no quick solutions to the problems. However, the operational commander who reviews the entire process of mine warfare and its countermeasures has a better chance of employing and assisting a Naval force in dealing with this threat. There are two purposes to this paper-first is to show that MCM operations are not just minesweeping/minehunting; second is to suggest that Army, Air Force, and Marine forces may be very useful in keeping the vital choke points in the Sea Lines Of Communication (SLOC) open against Naval mines.*

ACCESSION NUMBER: ADA266702

**Briggs, K.B. High-Frequency Acoustic Scattering from Sediment Interface Roughness and Volume Inhomogeneities.** Final rept. Naval Research Lab. Detachment, Stennis Space Center, MS: 5 Dec 94. 156p.

*ABSTRACT: High-frequency acoustic and geoacoustic data from five experiment sites with different sediment types are compared with predictions from the composite roughness model to ascertain the relative contribution of interface roughness and sediment volume scattering. Model fits to backscattering data from silty sediments indicate that volume scattering predominates, but measured bottom roughness was sufficient to explain the backscattering measured from a rippled, sandy sediment. Fluctuations in sediment porosity and sound velocity probably cause volume scattering, which is described by a free parameter in the composite roughness model comparisons. High-resolution vertical profiles of sediment porosity and compressional wave velocity collected from 14 diverse sites on continental shelves are used to calculate vertical spatial autocorrelation functions, variance of the fluctuations, and the dependence of sediment sound velocity and density on sediment porosity for parameterizing sediment volume inhomogeneity. Correlation lengths calculated from autocorrelation functions show maximum variability in poorly sorted sediments. The variance of porosity and velocity fluctuations, which determines the strength of volume scattering, exhibits wide variation with sediment type and depends on the processes that mix and transport sediments. Comparison of data from a large number of locations on continental shelves suggests that fluctuations in sediment porosity are due to biological and sedimentological processes and that fluctuations in sediment velocity are due to hydrodynamic processes.*

ACCESSION NUMBER: ADA291610

**Broughton, D.S. Application of the Analysis Phase of the Instructional System Development to the MK-105 Magnetic Minesweeping Mission of the MH-53E Helicopter.** Master's thesis. Naval Postgraduate School, Monterey, CA.: Sep 87. 95p.

*ABSTRACT: With the introduction of the MH-53E helicopter as a platform for airborne mine countermeasures, a new cockpit flight simulator was proposed. This simulator, device 2F141, will provide the U>S> Navy with the capability to simulate the flight environment of an airborne mine countermeasures mission. The method of the Instructional System Development (ISD) model was applied as a framework for development of a training program. This study concentrated on the analysis phase of the ISD process. Through the application of a task analysis and quantification methodology of the Mission Operability Assessment Technique (MOAT) a rank ordering of subtasks and major flight segments for the ship-based MK-105 magnetic minesweeping mission was determined. This study found that the major flight segments of landing, takeoff and preparation for tow, and transit to the minefield required the most improvement to increase the mission operability and effectiveness score. Therefore, a training program should be designed and developed that will effect these improvements by utilizing the cockpit flight simulator.*

ACCESSION NUMBER: ADA186282

**Carter, G.C. Submarine Sonar System Concepts for Littoral Waters (Preliminary Unabridged Version).** Final rept. Naval Undersea Warfare Center Div., Newport, RI: Jan 96. 17p.

*ABSTRACT: This documents contains the unabridged (original) manuscript submitted to the Naval Submarine League for publication in The Submarine Review.*

ACCESSION NUMBER: ADA304412

Cashman, T.M. **Sweeping Changes for Mine Warfare: Controlling the Mine Threat.**

Master's thesis. Naval Postgraduate School, Monterey, CA: Dec 94. 86p.

*ABSTRACT: This thesis proposes that the U.S. Navy deter and, if necessary, combat potential minelayers by pursuing a pro-active' offensive mine warfare strategy. Central to this proposed strategy is the development, acquisition, and use of Remote Controlled (RECO) mines. It is argued that, given the historical problems the United States has had in the area of naval mine warfare, a strategy aimed at the aggressive deterrence of enemy mine laying be embraced so as to project forces ashore in future amphibious operations.*

ACCESSION NUMBER: ADA293659

Clark, R. et al. **Mine Search System Model (MSSM).** Final technical rept. Alliant Techsystems, Inc., Arlington, VA. Advanced Technology Center: Dec 91. 67p.

*ABSTRACT: This document presents the results of conversion of a Honeywell internally-funded operator-interactive minefield penetration model to a DARPA-sponsored automated, high fidelity mine search system model (MSSM) capable of supporting Monte Carlo analysis. Major strengths of the converted model are: modularized construction, introduction of a current set and drift application, validation using at-sea derived data from SUBASWEX 3-89, heavy emphasis on replication of the sonar equation and environment, and resultant accurate simulations of SSN 688 and unmanned underwater vehicle (UUV) performance in minefield penetration runs. 3-D graphics were introduced parametric studies of UUV performance in a survey mission role were also completed, as were implications of multiplexing using an acoustic command link (ACL) between the UUV and SSN. Promising results of the first phase covered by this document have led to more advanced application of the MSSM under a NUSC-guided, DARPA-sponsored program during a two year period starting in December 1991.*

ACCESSION NUMBER: ADA245870

Compton, M.A. **Minefield Search and Object Recognition for Autonomous Underwater Vehicles.** Master's thesis. Naval Postgraduate School, Monterey, CA.: Mar 92. 257p.

*ABSTRACT: Autonomous Underwater Vehicles (AUV) are an outstanding minefield search platform. Because of their stealthy nature, AUVs can be deployed in a potential minefield without the enemy's knowledge. They also minimize dangerous exposure to manned and more expensive naval assets. This thesis explores two important and related aspects of AUV minefield search: exhaustive sensor coverage of a minefield through effective path planning and underwater object recognition using the vehicle's sensors. The minefield search algorithm does not require a priori knowledge of the world except for user-defined boundaries. It is a three-dimensional, prioritized graph search using a ladder based methodology and an A\* optimal path planning algorithm. The minefield search algorithm effectively ignores areas which are blocked by obstacles, performs terrain following and avoids local minima problems encountered by other area search solutions. The algorithm is shown to be effective using a variety of graphical simulators. The object recognition algorithm provides autonomous classification of underwater objects. It uses geometric reasoning and line fitting of raw sonar data to form geometric primitives. These primitives are analyzed by a CLIPS language expert system using heuristic based rules. The resulting classifications may be used for higher level mission planning modules for effectively conducting the minefield search. Actual NPS AUV swimming pool test runs and graphic simulations are used to demonstrate this algorithm which was built in cooperation with Lieutenant Commander Donald P. Brutzman, USN.*

ACCESSION NUMBER: ADA250093



Cottle, D.J. **Mine Avoidance and Localization for Underwater Vehicles Using Continuous Curvature Path Generation and Non-Linear Tracking Control.** Master's thesis Jun 92-Sep 93. Naval Postgraduate School, Monterey, CA. Dept. of Mechanical Engineering.: Sep 93. 74p.

*ABSTRACT: Many underwater vehicles have been designed to follow a straight path using linear approximations about that path. Tracking a dynamic path of arbitrary but continuous curvature may often be desired. This will require a nonlinear controller with enhanced robustness properties. One point of this thesis is to show how nonlinear control using sliding modes may be applied to follow a dynamic path. In a mine warfare setting using Autonomous Underwater Vehicles (AUVs), reflexive maneuvers will be required for mine avoidance. This thesis presents one way in which paths for mine avoidance maneuvers may be generated automatically and used as inputs to the nonlinear tracking control system of the vehicle. It has been shown through simulation that a random minefield can be traversed by an AUV while localizing and avoiding detected mines using these control concepts.*

ACCESSION NUMBER: ADA276070

Crawford, M.W. and R.L. Detwiler. **Through the Ice Mining Study.** Final rept. Epoch Engineering, Inc., Gaithersburg, MD.: Jun 83. 71p.

*ABSTRACT: A search for literature relevant to ice penetration by naval mines has shown that interest in the problem has existed since 1952. Early studies were followed by Arctic sea ice penetration tests using instrumented penetrators of varying sizes and weights. Empirical equations for prediction of ice penetration and longitudinal accelerations during ice penetration were originally developed by modification of earth penetration equations. Analysis of all available test data has validated the empirical equations within the originally stated limits of accuracy. Comparable test data appear to confirm the validity for structural tests of penetration testing in gypsite as a simulation of Arctic sea ice for the first few feet of penetration. Very little information exists concerning transverse acceleration and loading in either ice or gypsite. Parametric studies of mine design parameters for a typical moored mine with practical constraints show trends of the weight area factor relationship and the nose shape factor relationship to maximum thickness of ice perforation capability, the payload to penetration relationship and the weight efficiency of the payload in a constrained total weight system. The few data available suggest that the problem of structural survival of transverse loads may be far more severe than that of surviving the longitudinal deceleration forces.*

ACCESSION NUMBER: ADA174310

Deitchman, S. et al. **Air-Supported Anti-Infiltration Barrier.** Final rept. Institute for Defense Analyses, Alexandria, VA. Jason Div.: Aug 66. 68p.

*ABSTRACT: In this report we discuss a possible air-supported barrier or interdiction zone that would help to isolate the South Vietnam battlefield from North Vietnam. The ideas are not unrelated to proposals in this area that have been made previously, but they are perhaps explored in more depth than such ideas have been explained hitherto, and operations on a larger scale that have previously been considered are envisaged. Both advantages and difficulties are discussed, on the assumption of a relatively long war lasting several years. Part I gives some general views of the relation of such a barrier to the general course of the war; then in Part II we present a rough picture of the current infiltration system and of U.S. operations against the Ho Chi Minh Trail, as it has been presented to us in briefings. Part III, a system conception, is described for an air-supported barrier. An initial system is discussed, that could be largely operational within a year or so from go-ahead using nearly-available weapons, aircraft, and equipment. Even for such a system some component engineering will be necessary. Part IV gives a partial analysis of how such a barrier might be deployed, its potential impact on the communist war effort, and of strategic measures North Vietnam could take to circumvent it if it is successful.*

ACCESSION NUMBER: ADB954899

Eaton, D. **Canadian underwater mine apparatus: Unmanned performance validation of the second prototype second stage regulator.** DCIEM technical report no. 89-TR-44. Defence and Civil Inst. of Environmental Medicine, Downsview (Ontario): c1989. 15p.

*ABSTRACT: The Canadian underwater mine apparatus (CUMA) provides life support for a mine-countermeasures diver to depths of 80 m of seawater (msw). The design of the CUMA produces a breathing gas with constant oxygen partial pressure by mixing pure oxygen with a diluent, either nitrogen for diving to depths of 55 msw or helium for depths of 80 msw. A reliability test of the gas-mixing circuit, two manned evaluations of the CUMA, and a field trial proved that the gas-mixing circuit worked as desired. However, a crucial component in the diluent circuit, the second stage regulator, needed technical improvements to increase its compatibility with saltwater and helium. Changes were made and a test protocol was designed to evaluate the output characteristics, and to some extent the reliability, of the new regulator. This document describes the results of a series of tests performed to establish the linearity of the regulator, the coefficients of the regression line, and the repeatability of the relationship.*

ACCESSION NUMBER: MIC9206167

Eaton, D.J. and S.A. McDougall. **Project Review of the Experimental Diving Unit.** Semi-annual rept. Nov 93-Apr 94. Defence and Civil Inst. of Environmental Medicine, Downsview (Ontario): Jun 94. 46p.

*ABSTRACT: Two projects in EDU, development of a freeze-proof regulator and decompression tables for the Canadian Underwater Mine-countermeasures Apparatus (CUMA), continue to occupy the majority of the unit's time. Regulator development involved iterative testing and modification of two prototypes while two, four-week dive series were completed to add 173 more human exposures to the data base required to validate the CUMA decompression model and tables. The development of an integrated system of equipment for mine-countermeasures diving integrated well with the CUMA decompression table validation. During each dive series components, such as new weight harness prototypes or dry suit samples, were included in the dives so that development could continue in parallel with the table validation. Another project which dovetailed well with the CUMA decompression work was the development of the hand heating system under the Clearance Diver's Supplementary Heat project. Prototypes were evaluated during the CUMA decompression dives. This project has expanded to include whole body heating and electric suits for this purpose were obtained to compare their performance against the standard hot water suit.*

ACCESSION NUMBER: ADA284183

Eisenberg, P. **Research at the Hamburgische Schiffbau Versuchsanstalt Relating to Pressure Actuated Mines.** Technical rept. Naval Technical Mission in Europe: Oct 45. 135p.

*ABSTRACT: No abstract available.*

ACCESSION NUMBER: ADA953462

Elischer, P. and J. Howe. **Australia's Shock Testing Capability.** Defence Science and Technology Organisation, Canberra (Australia): 11 Feb 93. 9p. [Proceedings from the Institution of Engineers, Australia Dynamic Loading in Manufacturing and Service Conference Held in Melbourne, Victoria on 9-11 February 1990.]

*ABSTRACT: Australia's involvement in shock testing to evaluate the structural response of Naval vessels and ships' equipment to transient dynamic loads began in late 1970. It commenced with gaining the necessary understanding of underwater blast phenomena and culminated in the successful shock testing of an Australian designed and constructed, glass reinforced plastic (GRP), minehunter. Since then we have maintained an active role in conducting full scale shock trials to evaluate the vulnerability of vessels and*

*equipment supporting mine countermeasure operations. We also conduct smaller scale trials to support the submarine construction program and the various research tasks undertaken by DSTO. This paper presents an overview of the shock trials conducted to date, together with a brief description of facilities available and considerations which needed to be addressed when conducting such tests in shallow water.*

ACCESSION NUMBER: ADA2683340XSP

Elischer, P. and J. Howe. **Dynamic Loading in Manufacturing and Service: Australia's Shock Testing Capability.** Materials Research Labs., Ascot Vale (Australia): 11 Feb 93. 8p.

*ABSTRACT: Australia's involvement in shock testing to evaluate the structural response of Naval vessels and ships' equipment to transient dynamic loads began in late 1970. It commenced with gaining the necessary understanding of underwater blast phenomena and culminated in the successful shock testing of an Australian designed and constructed, glass reinforced plastic (GRP) minehunter. Since then we have maintained an active role in conducting full scale shock trials to evaluate the vulnerability of vessels and equipment supporting mine countermeasure operations. We also conduct smaller scale trials to support the submarine construction program and the various research tasks undertaken by DSTO. An overview of the shock trials conducted to date, together with a brief description of facilities available and considerations which needed to be addressed when conducting such tests in shallow water is presented.*

ACCESSION NUMBER: N94113040

Elliott, M.A. **Acoustic Transient Generator.** Patent. Department of the Navy, Washington, DC.

Filed 4 Aug 64, patented 2 Oct 90. 9p.

*ABSTRACT: This patent pertains to an underwater transient sound generator for broadcasting optimum acoustical sonic energy in sea water with an appropriate intensity and frequency spectrum to achieve passivation of acoustical mines. A high pressure bubble is released from a chamber while a resilient diaphragm is simultaneously vibrated, the diaphragm having at least one of its surfaces in contact with the sea water. The system provides an improved pneumatic-mechanical impact sound source that produces a controllable distribution of high power, broad band spectrum acoustical energy, to temporarily inactivate acoustical mines, while masking the noise of the ship as it passes the mine.*

PATENT: 4,961,181

Engebretson, K.R. **Comparison of Data Fusion Techniques for Target Detection with a Wide Azimuth Sonar.** Master's thesis. Air Force Inst. of Tech., Wright-Patterson AFB, OH: May 95. 127p.

*ABSTRACT: A group at the Charles Stark Draper Laboratory developed a concept for a mine reconnaissance platform called Intelligent Sonobuoy. This platform utilizes a low frequency sonar with wide aspect angle coverage. Furthermore the platform is designed to drift past an area of interest and thus obtain multiple detections from each sonar target. This thesis examines methods of fusing together those detections into a composite map of the target field in order to detect and localize those sonar targets. A technique based on hypothesis testing and maximum likelihood estimation is first derived and then applied to simulated data. Lastly, the system is validated on actual test data obtained in Mendum's Pond, New Hampshire during the summer and Fall of 1994. This system is shown to be effective at resolving targets to within a few meters. A competing approach based on the Hough transform is next examined. This clustering technique is applied to find the change in target location with respect to the buoy's position. The system works for simulated test data with a small number of detections. System performance declines rapidly as the number of detections increases and the system does not work well with the actual test data.*

ACCESSION NUMBER: ADA296540

Fanta, P.J. **Sea Mines at the Operational Level of War.** Final rept. Naval War Coll., Newport, RI: 13 Feb 95. 21p.

*ABSTRACT: Sea mines represent a significant challenge to the operational commander both in operational planning and execution. Mining affects all levels of warfare: strategic, operational and tactical. Through historical example, the impact of mines at the Operational level of war can be readily demonstrated. Analyzing lessons learned shows how mines can affect operational maneuver, operational tempo, surprise, and security. Additionally, since mines are inexpensive, plentiful, and can be easily placed, planning for mine countermeasure operations is a requirement for every operation, large or small. Using historical examples for a framework, a conceptual model to evaluate the need for mine countermeasures planning can be created, allowing for advance planning and for tailoring operations to better meet the threat.*

ACCESSION NUMBER: ADA293702

Fowler, J.E. et al. **Cooperative Laboratory and Field Study to Investigate Effects of Wave and Current Action on Dual-Rocket Distributed Explosive Array Deployment.** Final rept. Coastal Engineering Research Center, Vicksburg, MS: May 93. 73p.

*ABSTRACT: A series of 2-D (flume) laboratory and field tests were conducted to examine effects of waves and currents on a simulated dual-rocket distributed explosive array deployment (DRDEAD) system. The DRDEAD system consists of a large array of explosive material which can be deployed by rockets launched from Navy vessels across the surf zone in a mine-clearing operation. The U.S. Army Engineer Waterways Experiment Station (WES) Coastal Engineering Research Center's mid-scale 2-D facility was used to examine various wave conditions, methods of deployment, and anchoring systems for a simulated (inert) DRDEAD. Waves simulating sea state 3 conditions and lower (i.e., calm seas to 5-ft prototype waves) were used in the laboratory study. Laboratory tests indicated that sea state 3 will be a limiting condition for deployment of the array without additional weights or anchors. Field tests to assess effects of wave and current were conducted during the summer of 1992 at CERC's Field Research Facility (FRF) in Duck, North Carolina. Results of the field tests supported laboratory findings, but also indicated that longshore currents are likely to have equal or greater effects on the DRDEAD system and must be considered in the final design.... Array embedment, Explosive array, Landing craft, air cushion Buoys, Explosive array deployment, Longshore currents Coastal Engineering, Fall speed, Scaled model Research Center, Field tests Shallow Water Mine Countermeasures DRDEAD, IHDI/NAVSURFWARCEN, Program Dual-rocket distributed Indian Head Division SWMCM explosive array deployment, Laboratory tests Waterways Experiment Station Duck, North Carolina, LCAC.*

ACCESSION NUMBER: ADA266082

Fowler, J.E. et al. **Field Study on the Effects of Waves and Currents on a Distributed Explosive Array.** Final rept. Coastal Engineering Research Center, Vicksburg, MS: Dec 93. 82p.

*ABSTRACT: Field tests to assess the effects of waves and currents were conducted during the summer of 1993 at CERC's Field Research Facility (FRF) in Duck, NC. This test series is a follow-on to similar efforts accomplished in 1992 and was designed to incorporate lessons learned from those efforts. Major differences between the 1993 tests and those conducted in 1992 involved the use of a wider array, a compressed air gun to simulate the dual-rocket deployment technique, and shore-based tethers to stabilize the deployed array. Results of the 1993 field tests generally supported 1992 findings, which indicated that both waves and longshore currents have significant effects on the explosive array deployment system and must be considered in the final design. The tests also indicated that wide arrays used in conjunction with the tethers proved to be quite stable under the environmental conditions tested.* ACCESSION NUMBER: ADA275478

Fowler, R.W. **Mine Countermeasures at the Operational Level of War.** Final rept. Naval War Coll., Newport, RI. Dept. of Operations: 12 Nov 93. 32p.

*ABSTRACT: This paper examines the complex problems and difficulties facing an operational commander when conducting operations in a mine threat environment. A discussion of mine warfare history, operational considerations, and today's mine countermeasure assets as well as a hypothetical situation that a commander may actually be faced with in today's global crisis-oriented climate is considered. The ability of the U.S. Navy to accomplish its primary strategic goal of Power Projection in a mine-threat environment is extremely difficult and limited. The panacea for present day MCM operations is recognition of the threat, knowledge of own capabilities, fleet training, and frugal management of MCM assets.*

ACCESSION NUMBER: ADA265300

Gallagher, D.I. **Sea Lane Defense: Japanese Capabilities and Imperatives.** Master's thesis. Naval Postgraduate School, Monterey, CA.: Dec 87. 160p.

*ABSTRACT: Japan has significant capabilities to protect its sealanes out to 1000 nautical miles to the south of its main ports. By concentrating military expenditures on forces to improve air defense, strait control, and convoy operations, Japan could have a credible defense, even in the worst possibility: global war and a Soviet attack. The Japanese should concentrate on improving the air defense of Japan and the ocean between Iwo Jima and Okinawa, increasing their stockpile of mines and their mine warfare forces, and increasing the numbers of their long-range maritime patrol aircraft and surface escort ships. These improvements all maintain the defensive nature of Japanese forces and are attainable within the next decade.*

ACCESSION NUMBER: ADA189173

Gambiez, G. **Should We Fear Mine Warfare.** Study project. Army War Coll., Carlisle Barracks, PA.: 30 Mar 89. 44p.

*ABSTRACT: Mines are weapons. Thanks to the improvements allowed by electronics they become more and more efficient and cost effective. On land as well as at sea, they would be widely used at theater level by all belligerents in all types of conflicts. Unfortunately improvements in mine countermeasures are more difficult to realize and to use on the field. The nations of the free world should increase their efforts in the domain of those countermeasure systems, or they risk being the first victims of the increasing advances in mines and mine delivery systems. The problem is as difficult as urgent.*

ACCESSION NUMBER: ADA209180

Game, C.V. **Defensive Minefield Planning.** Master's thesis. Naval Postgraduate School, Monterey, CA.: Jun 89. 79p.

*ABSTRACT: This thesis is concerned with the problem of constructing an optimal minefield for inflicting casualties to a naval force attempting to penetrate the field. A microcomputer based simulation program dealing with this problem is presented and permits the user to select various mine characteristics (charge weight, depth, sensitivity), number of mines, number of transitting ships and navigational error.*

ACCESSION NUMBER: ADA215142

Garrigan, R.J. **Cost Analysis of MH-53E Avionics Maintenance Support Alternatives for Remote Deployment.** Master's thesis. Naval Postgraduate School, Monterey, CA.: Sep 87. 64p.

*ABSTRACT: The United States Navy is in the process of considering the use of Mobile Maintenance Facilities to provide an intermediate level maintenance capability to MH-53E helicopter minesweeping and mine countermeasure squadrons of four and seven aircraft while on deployment to remote locations. This thesis*

considers two alternatives: (1) no intermediate maintenance capability and, (2) full capability. Because of limited data only the repair of avionics components are considered. The alternative corresponding to no maintenance capability provides the increased inventory required to meet expected failures. The second alternative involves all of the elements of intermediate maintenance at a remote site as well needed supply support. Present value analyses of the life cycle costs are utilized to determine the least cost alternative. The results suggest that intermediate maintenance activities are the least cost alternative for avionics support for a seven-aircraft detachment and the most costly alternative for the four-aircraft detachment.

ACCESSION NUMBER: ADA186220

Gellert, E.P. et al. **Use of Composites in Naval Structures.** Materials Research Labs., Ascot Vale (Australia): 1992. 20p.

*ABSTRACT: Composite materials in the form of glass-fiber reinforced plastic (GRP) and GRP/foam sandwich are being increasingly applied to naval vessel construction. Candidate materials will respond differently to elevated temperatures, moist environments and fires. Some of the effects are described here. The bolted jointing of GRP to steel has been assessed.*

ACCESSION NUMBER: ADA270308

Glaz, J. **Statistical Methods for Minefield Detection.** Interim rept. Connecticut Univ., Storrs. Dept. of Statistics: 24 May 94. 12p.

*ABSTRACT: The Navy and the Marine Corps have been continually concerned about the antivehicle and antiship mines. The development of effective minefield detection procedures are of great importance as they will enhance the ability of the Navy and Marine Corps to perform their tasks. One approach that has been recently studied by the scientists of the Navy is the use of tests of randomness. In that study they express the need to develop detection methods that are based on two-dimensional processes that incorporate the dependence structure of the nearby observations. In this interim performance report four research projects related to this problem are discussed. The two-dimensional scan statistic, discussed in the last project, has the potential to be very useful in the minefield detection problem.*

ACCESSION NUMBER: ADA282161

Gluth, J.V. **Is the Navy's Mine Warfare Posture Bankrupt.** Final rept. Naval War Coll., Newport, RI. Dept. of Operations.: Jun 91. 33p.

*ABSTRACT: This paper addresses the Navy's posture on mine warfare (MIW). The purpose is to examine the perception that the Navy's MIW capabilities are inadequate and that appropriate corrective actions are not being taken. Despite MIW's lack of strong congressional sponsorship enjoyed by other warfare specialties, the Navy has developed a highly capable and responsive force of mine countermeasures (MCM) helicopters and ocean-going vessels, as well as the capability of providing limited MCM through the Craft of Opportunity Program (COOP). Even though a high proportion of MCM capability resides in the Naval Reserve Force, the channel survey and conditioning function they perform contributes directly to the readiness posture of the active Navy. The Navy's MIW posture is not bankrupt, but is vital and forward looking. Recommendations provided include expanding the COOP, protecting the Reserve MCM role, and institutionalizing the benefit of MIW experience among the officer corps.*

ACCESSION NUMBER: ADA236976

Gould, J.W. **German Navy Moored Minesweeping.** Technical rept. Naval Technical Mission in Europe: Oct 45. 73p.

*ABSTRACT: This report discusses the gear developed by the German Navy for moored minesweeping. This gear was limited in size by the policy of handling all gear by hand. The material for this report was obtained from the German Naval Experimental Mine Warfare Command (SVK) located in Kiel.*

ACCESSION NUMBER: ADA954501

Green, D.M. **Monitoring Technology Proliferation: An Open Source Methodology For Generating Proliferation Intelligence.** Master's thesis. Naval Postgraduate School, Monterey, CA: Dec 93. 108p.

*ABSTRACT: This thesis develops a methodology to monitor technology proliferation. It is designed to provide proliferation intelligence on specific threat technologies and can be used to augment export controls or enhance counter proliferation initiatives. A high-tech component used to upgrade underwater mines is the subject of the case study developed in this thesis. This technology monitoring method exploits the exponentially expanding volume of open source information occurring as a result of the information revolution.*

ACCESSION NUMBER: ADA277295

Greer, W.L. and J.C. Bartholomew. **Psychological Aspects of Mine Warfare.** Center for Naval Analyses, Alexandria, VA. Naval Studies Group.: Oct 82. 24p.

*ABSTRACT: This paper examines historical and physiological data concerning mine warfare. It then goes beyond those observations to consider how the psychological warhead in minefields can be exploited.*

ACCESSION NUMBER: ADA128244

Holden, K.T. **Mine Countermeasures: What the Operational Commander Must Know.** Final rept. Naval War Coll., Newport, RI. Dept. of Operations: 8 Feb 94. 35p.

*ABSTRACT: A great deal has been written concerning the need for more and improved mine countermeasures equipment. What seems lacking is adequate focus at the operational level regarding how to effectively and efficiently employ existing systems in support of current and future operations. In many situations, to achieve a military objective, it is essential the operational commander know the existing or potential mine threat, understand current mine countermeasure capabilities, determine the available courses of action, and select the course of action that will provide the highest probability of success in support of an assigned mission. This paper is intended to emphasize the importance of mine countermeasures to the operational commander. It draws upon the lessons of history to show that mine warfare has had a significant impact on naval and joint operations. While the paper addresses some technical and tactical aspects of mine countermeasures, the primary focus is on the operational considerations and options available to the operational commander.*

ACCESSION NUMBER: ADA279712

Hong, Y.S. **Improved Prediction of Drift Forces and Moment.** Final rept. David W. Taylor Naval Ship Research and Development Center, Bethesda, MD.: Sep 83. 43p.

*ABSTRACT: A three-dimensional method is developed to improve the computation of the drift force and moment for small-waterplane-area, twin-hull (SWATH) and surface ships in oblique waves with zero forward speed. Numerical results have been computed for three ships: SWATH 6A, Stretched SSP, and MCM experiment. For MCM 5371, the results of two- and three- dimensional methods are almost identical to each other and these results show good agreement with experiment when the wavelength ratio is not too small. Even though there are no test data available for SWATH 6A, the application of three dimensional theory is likely to improve the results of drift force and moment for SWATH ships.*

ACCESSION NUMBER: ADA134055

Hurley, W.J. et al. **General Approach to Investing in the New Modeling and Simulation Tools With A Case Study: Naval Mine Countermeasures Programs.** Institute for Defense Analyses, Alexandria, VA: Jul 95. 218p.

*ABSTRACT: Recent advances in computing, networking and visualization have led to dramatic improvements in modeling and simulation (MS) capabilities. The key issue for DoD is how to successfully convert these impressive technical developments into useful tools for addressing DoD's needs. This study proposes a general framework for deciding how to invest in the new MS tools. The framework begins with an articulation of a key need facing the decision maker. It then addresses the potential roles for MS in meeting that need, the implied characteristics of the MS tools, their costs, value added, risks, funding, and management. It then repeats this process for a range of needs facing the decision maker, and, by looking for common elements and setting priorities, seeks to integrate the results across all of the needs into a single MS plan. As a case study, this process is applied to the area of naval mine countermeasures (MCM). No detailed road map for MS investment is given, but the issues that arise are described along with some methods that may be used to resolve them. A strawman approach to MCM MS investments is presented. This is a 'fleet first' approach which focuses initially on training, tactical development and mission rehearsal with later applications to acquisition once acceptance of the MS tools, and confidence in them, have been established. The general framework described should be applicable to any area where the benefits and costs of the new MS tools are under consideration.*

ACCESSION NUMBER: ADA305451

Ingold, B.W. **Key Feature Identification from Image Profile Segments Using a High Frequency Sonar.** Master's thesis. Naval Postgraduate School, Monterey, CA: Dec 92. 67p.

*ABSTRACT: Many avenues have been explored to allow recognition of underwater objects by a sensing system on an Autonomous Underwater Vehicle (AUV). In particular, this research analyzes the precision with which a Tritech ST1000 high resolution imaging sonar system allows the extraction of linear features from its perceived environment. The linear extraction algorithm, as well as acceptance criteria for individual sonar returns are developed. Test results showing the actual sonar data and the sonar's perceived environment are presented. Additionally, position of the sonar relative to the perceived image is determined based on the identification of key points in the scene.... Autonomous Underwater Vehicle (AUV).*

ACCESSION NUMBER: ADAA261926

**Integrated Logistics Support Management Plan for the Remote Minehunting System (RMS).** Naval Sea Systems Command, Washington, DC: Sep 91. 35p.

*ABSTRACT: Provide a management plan for ensuring that support elements, for the Remote Minehunting System (RMS) are available for delivery upon turn-over of the of the RMS from CSS to the Fleet.*

ACCESSION NUMBER: ADA255806

Jappinga, E.M. and D.L. Patel. **Technical Transfer Report on a TNT Enzymoluminescent Vapor Detection System.** Final technical rept. Army Belvoir Research Development and Engineering Center, Fort Belvoir, VA: Feb 91. 104p.

*ABSTRACT: This report describes the historical breadboard effort with enzymoluminescent 2,4,6-trinitrotoluene (TNT) vapor detection system. The system comprises a sample train, vapor generator, and luminescence detector using a TNT reductase enzyme. This breadboard system is the culmination of a long-term effort evolving from several programs that examined the TNT enzymoluminescent and bioluminescent response of marine bacteria, antibodies, and enzymes under BRDEC auspices. This program was suspended by BRDEC because its slow reaction time (total more than 22-minutes sampling and detection time with a 0.25 part per trillion (ppt) TNT-in-air lower detection limit) and therefore cannot be used for mine*



*detectors. This report discusses an engineering design analysis that was performed for a new configuration of an enzylluminescent TNT vapor detection system that utilizes an integrated sample-reactor module to provide an estimated TNT rate-of-response of less than 60 seconds and a 0.0025 ppt minimum detectable concentration. This improvement can be of significant value in noncountermine applications. The most feasible and adaptable current application for the conceptual system is that of enclosure monitoring (building, room, etc.) for the presence of TNT vapors. The report describes system operation and use is examined in these applications.*

ACCESSION NUMBER: ADA233444

Jasper, N.H. **Ship Signature Modifier**. Patent. Department of the Navy, Washington, DC: Filed 27 Nov 68, patented 21 Sep 93. 6p.

*ABSTRACT: A unique system of disposition-controlled, water-filled, fabric bags is suspended from and towed beneath a ship to effect the modification of the inherent water pressure signature thereof and thus prevent detonation of a marine mine programmed to be exploded thereby.*

PATENT: 5,245,928

Kern, G.E. **Mine Neutralization System**. Patent. Department of the Navy, Washington, DC.: Filed 22 Mar 67, patented 4 Dec 90. 7p.

*ABSTRACT: This patent discloses a mine neutralization system having self-propelled explosive charges fired at submarine mines by a mine detection and fire control system.*

PATENT: 4,975,888

Kirkland, J.L. **Electrical Cable Marker**. Patent. Department of the Navy, Washington, DC: Filed 13 Feb 75, patented 20 Nov 90. 7p.

*ABSTRACT: A marine mine control wire tagging system is disclosed as including a transmitter and a receiver, a mobile underwater vehicle having a launcher mounted thereon, a radio frequency signal tag loaded in said launcher, a sensor and a fire control system for launching said tag upon the detection of said marine mine control wire by the aforesaid sensor. If so desired, said transmitter and receiver may be mounted on a boat which also tows said underwater vehicle to a position in proximity with said control wire.*

PATENT: 4,972,388

\_\_\_\_\_. **Radio Frequency Phase Sensitive Wire Detector**. Patent. Department of the Navy, Washington, DC: Filed 20 Apr 73, patented 28 Sep 93. 7p.

*ABSTRACT: An underwater object detection system and method are described which utilize changing phase relationships between radio waves received by a moving underwater receiver, via a retransmitting underwater object, and radio waves received through air directly from a transmitter. The moving underwater receiver is characterized by an envelope or encapsulation of material of different radio wave propagation rate than that of the water medium, so that a markedly different phase change relation exists when the underwater receiver is in contact with the object.*

PATENT: 5,249,162

\_\_\_\_\_. **Regenerative Radio-Frequency Wire Detector**. Patent. Department of the Navy, Washington, DC: Filed 7 Jan 72, patented 14 Sep 93. 8p.

*ABSTRACT: A regenerative radio-frequency wire detector is disclosed which incorporates a radio antenna and a radio receiver connected thereto. A radio transmitter is timely energized by an output signal from the aforesaid radio receiver which, in turn, causes the transmitting of electromagnetic energy within the environment ambient to the wire to be detected. A commercial radio station or other source is employed as*

*a covert initial energizer of the wire to be detected. When so energized, said wire re-radiates electromagnetic energy to the receiving antenna which starts the regenerative processing within the system loop constituting the radio receiving antenna, the radio receiver, the radio transmitter, the transmitting radio antenna, the wire, and the environmental medium or mediums within which it is disposed. Due to the amplification effected by the aforesaid regeneration process, the detection of marine mine command wires, for example, is facilitated.*

PATENT: 5,245,588

Kish, L.A. **Acoustic Mine Countermeasures.** Patent. Department of the Navy, Washington, DC. Filed 9 Dec 63, patented 13 Nov 90. 7p.

*ABSTRACT: This patent discloses a mine sweeping method and related apparatus for achieving at least temporary passivation of underwater acoustic influence mines by the generation of particular underwater sounds of progressively increasing intensity. The water is acoustically pulsed by repetitively injecting into the water individual metered slugs of heated water, which water is heated to its saturation pressure but below the critical point. The metered slugs of heated water may be of the same or of progressively increasing size, i.e. weight, and can be released from a heated pressure chamber into the water from either a stationary array or from an array towed from a moving ship, and at a depth such that the expanding bubbles, produced by the change of state of the heated water, do not break the water surface. The rapid expansion of the metered slugs produce the desired sound output for temporarily rendering the acoustic influence mines passive actuating their anti-countermine circuits.*

PATENT: 4,969,399

Kleijnen, J.P.C. and G.A. Alink. **Validation of Simulation Models: Mine-Hunting Case-Study.** Research memo. Tilburg Univ. (Netherlands). Dept. of Economics: Feb 92. 38p.

*ABSTRACT: Stringent validation requires that simulation and real-life responses have the same mean. The responses, however, may show not only sampling error but also measurement error. Moreover, simulated and real responses are not comparable if they are obtained under different environmental conditions or scenarios. Modules within the simulation model should be submitted to sensitivity analyses based on experimental design theory and regression analysis. A weaker validation procedure tests whether the estimated simulation and real responses are positively correlated (they do not necessarily have a common mean). These issues are illustrated through a study on mine hunting at sea by means of a sonar.*

ACCESSION NUMBER: PB9220891

Krauss, H.J. **From the Sea in 1950: Lessons for the 21st Century From Operation Chromite.** Final rept. Naval War Coll., Newport, RI. Dept. of Operations: 22 Feb 93. 35p.

*ABSTRACT: The Navy and Marine Corps' combined vision for the 21st Century is articulated in the joint White Paper . . . From the Sea. The focus is designed to provide a direction for the Naval Expeditionary Forces to proceed in shaping its forces in support of the National Security Strategy. The new direction is to be shaped for joint operations and structured to build power from the sea, operating forward in the littoral regions of the world. The purpose of this paper is to conduct a historical study of the United States' last major amphibious operation, with joint/combined force during a major regional conflict. Current national demobilization trends mirror the strategic culture of the late 1940s. The study of Operation Chromite: The Inchon-Seoul Campaign of 1950, revealed a nation ill prepared to respond to a major regional conflict due to a precipitous demobilization. The operational art employed by General MacArthur during Operation Chromite capitalized on synchronized amphibious maneuver and interdiction to attack North Korean centers of gravity. The success of the operation highlighted the importance of understanding the operational art, pursuing specialized amphibious training, and maintaining the capability of generating*

*superior firepower. The weaknesses our Naval Service will bring into the 21st Century for a littoral Navy are insufficient naval gunfire, mine countermeasures, and amphibious lift resources.... National Security Strategy and Amphibious Operations.*

ACCESSION NUMBER: ADA264284

Kusumoto, N.J. **Lost Art of Maritime Mining.** Final rept. Naval War Coll., Newport, RI.: 13 Feb 95. 34p.

*ABSTRACT: Maritime minefields have been employed to achieve strategic and operational objectives in the five major American wars of the 20th century. The United States has been both the miner and, most recently, the victim. Mining can strike at the heart of the enemy, take advantage of an Achilles' heel, or compensate for one's own weakness. The U.S. Navy maintains a modest inventory of mines which can be laid in volume by Navy and Air Force aircraft, or covertly by submarines. Today's operational commander faces an increasingly challenging task: tackle a diverse, changing threat with fewer forces and resources without alienating the American public. Minefields can be an integral part of the plan to achieve battlespace dominance and project power. Mining can seize the initiative through surprise, enhance mass and maneuver by achieving economy of force, and expand the commander's battlespace and timeline while compressing those of the enemy. A minefield is a stealthy, persistent, and economical weapon which can deter without killing. Against a maritime foe, the operational commander should consider mining's strategic and operational potential when planning a major operation.*

ACCESSION NUMBER: ADA293379

Lawson, K.R. and D.D. Richardson. **Australian Mine Sweeping Game.** Technical rept. Materials Research Labs., Ascot Vale (Australia): Feb 94. 34p.

*ABSTRACT: This Note describes the Australian Mine Sweeping Game (AMSG). The game represents minesweeping and enables MCM officers to become more familiar with the consequences of various sweeping tactics. The game is designed for a single Player (or a team of Players working together) and an Umpire. The Umpire can lay a minefield, selecting mines from a list of five types. The scene can be set for the Players, and their performance monitored. The Players appraise the situation, and then devise the tactics for sweeping the minefield. Hints are provided on likely mines in the field. The game will show the Players how effective the tactics they chose proved to be, by showing a simulation of the minefield being swept.*

ACCESSION NUMBER: ADA279264

Laxar, K. et al. **Relative Effectiveness of Four Color Coding Techniques for Intensity Coding on Simulated Advanced Mine Detection System (AMDS) Displays.** Interim rept. Naval Submarine Medical Research Lab., Groton, CT: 10 Sep 93. 17p.

*ABSTRACT: Four methods of color coding the intensity levels of sonar returns on the Advanced Mine Detection System displays, currently under development, were studied to determine how the added use of color could enhance operability. The target detection and identification performance of seven experienced observers was measured using the following schemes for coding signal intensity into eight discrete steps: levels of green (the original coding method), levels of white, colors approximating specifications supplied by the Naval Undersea Warfare Center (NUWC), and colors arranged according to lightness, from dark to light. A portion of a static AMDS display 726 pixels wide by 323 pixels high was simulated on a computer controlled color display system. A single target simulating six sonar pings, or histories, was six pixels wide (10.2 arc min visual angle) by one pixel high, and was present on 50% of the trials. It could be located anywhere in the background. Four target signal strengths were used. The randomized distributions of the background noise levels and the target levels were specified by NUWC and considered to be representative of those expected at sea. Each observer ran on two 100-trial sessions of each of the 16 conditions, combinations of one of the four target strengths and one of the four color coding schemes. In a signal*

*detection paradigm, for each trial the observer signalled, by key press, confidence in the presence or absence of a target on a four-point scale, and indicated the location of the target, when present, by means of a trackball cursor. The hit rates (percentage of trials Decision making, Tactical displays, Human subjects, Visual sonar displays, Performance.*

ACCESSION NUMBER: ADA275196

**Lessons of the Falklands.** Summary Rept. Department of the Navy, Washington, DC.: Feb 83.  
78p.

*ABSTRACT: Contents: Air Operations; Antiair Warfare/Antiship Missile Defense; Antisubmarine Warfare; Antisurface Warfare; Amphibious Warfare; Command, Control, and Communications; Electronic Warfare; Intelligence; Environmental Conditions; Logistics/Sustainability; Mine Warfare; Personnel; Press Coverage; Readiness and Mobilization; Ship Survivability; Special Forces Operations; Submarine Operations; Surface Ship Operations.*

ACCESSION NUMBER: ADA133333

**Lindgren, E.D. Impact of Mine Warfare upon U.S. Naval Operations during the Civil War.**  
Master's thesis. Army Command and General Staff Coll., Fort Leavenworth, KS: 1994.  
119p.

*ABSTRACT: This study investigates the impact of Confederate naval mine warfare against the operations of the U.S. Navy during the Civil War. Mine warfare was a cost effective method for the Confederacy to defend its long coastline and inland waterways. A wide variety of fixed, moored, and drifting mines were deployed and used with effect at locations along the Atlantic coast, the Gulf coast, and along rivers, including those in the Mississippi basin. Despite loss and damage to thirty-five Union naval vessels, mine use had virtually no strategic impact upon the course of the war. At the operational level, effects were apparent. Federal naval operations at Charleston and on the Roanoke River were frustrated, in large part because of the mine threat. The impact of mines was great at the tactical level. These cost effective weapons caused delays in Union operations, resulted in involved countermine operations, and caused fear and apprehension in crews. The lessons from the mine warfare experience of the Civil War are still applicable in today's warfare environment. Naval mines are a preferred weapon of minor naval powers and the U.S. Navy will be required to deal with this threat when operating in the World's coastal regions.*

ACCESSION NUMBER: ADA284553

**Lluy, P.A. Mine Warfare: An Old Threat Presents New Challenges for NATO's Post-Cold War Navies.** Master's thesis. Naval Postgraduate School, Monterey, CA: Dec 95. 211p.

*ABSTRACT: This thesis analyzes the possible implications to global maritime interests posed by the growing international proliferation of advanced sea mines, and examines the role of NATO's mine countermeasures (MCM) forces in countering this threat in the post-Cold War security environment. It is argued that, given the Iraqi mining success during the Gulf War, the current global proliferation of sophisticated sea mines, and deficiencies in the international laws which govern their use, mine warfare will present a growing threat to vulnerable Western nations into the next century. Consequently, NATO's mine countermeasure forces will have a prominent role in future Alliance or UN-mandated out-of-area naval contingencies, ranging from counter-terrorism operations to major regional conflicts, and will be called upon to provide a credible MCM capability to protect Alliance and coalition naval forces, secure vital sea lines of communication (SLOCs), and ensure unimpeded maritime freedom of the seas prescribed under international law. NATO's capability to meet these challenges will depend largely on its ability to reorient its focus toward the requirements necessary to train and maintain a first-rate MCM rapid deployment force. As a leader within NATO, the United States Navy must assume the lead in forging multinational transatlantic MCM forces capable of dealing with any global mining contingency.*

ACCESSION NUMBER: ADA305846

**Logistics Support Analysis Strategy, Working Papers Remote Minehunting System (RMS).** Naval Sea Systems Command, Washington, DC: 1991. 67p.

*ABSTRACT: Document is an initial, tailored implementation of the LSA and LSAR requirements for the RMS program.*

ACCESSION NUMBER: ADA255807

**Lu, H.C. Using Expert Systems in Mine Warfare.** Master's thesis. Naval Postgraduate School, Monterey, CA.: Jun 91. 90p.

*ABSTRACT: Historically, sea mines warfare have played an important role in warfare, which a naval officer cannot afford to neglect. During the recent mine campaign in the Middle East involving Iran and Iraq, commanders delayed decisions on whether or not to deploy mine countermeasure (MCM) forces. As a result, damage occurred to ships in a minefield that could have been prevented by the speedy application of MCM. Before the operational mission commenced, there are several uncertain questions in the mind of the commander: Do the mine-fields exist. Which country laid the mines. What type of delivery platform laid the mines. Where are the mines. What kind of mines are they. Do we need to deploy the MCM forces. Previously, these kinds of fuzzy questions were very difficult to answer by a tactical principle. In this thesis, the probabilistic inference network in the expert system environment is used to answer the above questions. The probabilistic inference network method is supported by the certainty factors. Calculations involving quantitative probabilities for answers to the above questions could enable the MCM experts to offer suggestions to the commander for reducing the ship's vulnerability at sea during wartime.*

ACCESSION NUMBER: ADA247758

**Marolda, Edward J. and G.W. Pryce. A Select Bibliography of the United States Navy and the Southeast Asian Conflict 1950 - 1975.** Naval Historical Center, Washington, DC. : Jun 82. 54p.

*ABSTRACT: General Titles; Strategy, Tactics, and Policy; Air Operations; Riverine Operations; Coastal Patrol; Amphibious Warfare; Naval Gunfire Support; Special Operations; Mine Warfare; Advisors and Military Assistance; Civic Action; Maritime Evacuations; Military Construction; Logistic Support; Medical Support; Ships, Weapons, and Material; Prisoners of War; Tonkin Gulf Incident; Miscellaneous.*

ACCESSION NUMBER: ADA122955

**Martin, P. et al. Proceedings of the Ship Control Systems Symposium (5th), Held at U. S. Naval Academy, Annapolis, Maryland on October 30 - November 3, 1978.** Volume 2. David W. Taylor Naval Ship Research and Development Center, Annapolis, MD: 3 Nov 78. 349p. [See also Volume 3, AD-A159 083.]

*ABSTRACT: Partial contents: Ship Handling Simulator; Ship Control Centre Training Facilities for the Royal Navy; Ship Maneuverability Transducer Controlled by Mini-Computer for Training Ship - Onboard ship handling simulator; Modern Control Theory for Dynamic Positioning of Vessels; Design and Simulation of Navigation and Ship Control Algorithms for a Minesweeper; Automatic and Manual Control of the 'Tripartite' Minehunter in the Hover and Track Keeping Modes - a Preliminary design; Reversing Dynamics of a Gas Turbine Ship with Controllable-Pitch Propeller; Transient Behavior of Gasturbo-electric and Fixed Pitch Propeller; Gas-Turbine Simulation Techniques for Ship Propulsion Dynamics and Control Studies; New Ship Technical Control Systems for the Royal Norwegian Navy; Development of a Machinery Control and Surveillance System for a Mine Countermeasures Vessel; Developments in Marine Gas Turbine Condition Monitoring Systems; Optimal Control of Hydrofoil Ship Lateral Dynamics; Future Propulsion Control System Functional Requirements; and High Power Superconducting Ship Propulsion System - Its control functions and possible control schemes.*

ACCESSION NUMBER: ADA159082

**MAS Bulletin. Soundtrak ASW Target Simulator. Military applications summary bulletin.** Office of Naval Research European Office: 8 Mar 89. 1p.

*ABSTRACT: Thorn EMI Electronics LTD, a Uk company, has developed an ASW target simulator called 'Soundtrak' which is a towed low-frequency sound source capable of providing a realistic acoustic target for training the crews of submarines and surface ships equipped with towed arrays and aircraft fitted with sonobuoys. Soundtrak can also be used as an effective deceptive acoustic countermeasure. Given a suitable winch and towed-body handling facilities, Soundtrak can be deployed from any vessel. Soundtrak provides the following: A realistic acoustic signature for operators and command teams, thereby reducing the need for deployment of both ships and submarines in an exercise role; Simplified performance assessment of noise ranges and all types of passive sonar including towed arrays and bow, flank, intercept, and sonobuoy systems; Improved training in antisubmarine warfare techniques for surface ships, submarines, fixed-wing aircraft, and helicopters; Acoustic and mine countermeasure capabilities; and A low-frequency sound source for scientific and experimental purposes.*

ACCESSION NUMBER: ADA270692

**Mason, R.I. Harbor Approach-Defense Embedded System.** Patent. Department of the Navy, Washington, DC. Filed 27 Jun 91, patented 11 Aug 92. 10p.

*ABSTRACT: Acoustically mapping (fingerprinting) the main channel, or 'Q' routes, of a harbor, over relatively long time periods by using transducers anchored near the harbor or Q route floor. Sonar pulse returns are processed so that echoes from acoustic targets are constantly monitored and integrated over long periods of time. The integrated sonar data are used to establish a characteristic bottom-image map for the presence and location of permanent objects such as debris, underwater formations and the like. The long term, integrated record is obtained to establish a reliable acoustic fingerprint or reference mapping of the bottom. This acoustical record or map, which is quite stable over long periods of time, is used to compare newly detected acoustic variances from the established map. A combination of active and passive acoustic sensors that are installed at fixed positions submerged in the channel permit the determination of both range and bearing when an intruding object has been detected.*

PATENT: 5,138,587

**McFee, J.E. and Y. Das. Advances in the Location and Identification of Hidden Explosive Munitions.** Defence Research Establishment Suffield, Ralston (Alberta): Feb 91. 96p.

*ABSTRACT: No abstract available.*

ACCESSION NUMBER: ADA233665

**McIntyre, T.A. Ultrasonic Acoustic Characteristics of Air Bubbles in the Surf Zone.**

Master's thesis. Naval Postgraduate School, Monterey, CA: Sep 95. 119p.

*ABSTRACT: Understanding the movement of sediment in the nearshore region due to wave motion and longshore currents is important in beach erosion studies, and has tactical significance in beach front mine warfare. Using ultrasonic acoustic backscatter, the Coherent Acoustic Sediment Flux Probe (CASP) is capable of tracking the movement of scatterers within the surf zone. Laboratory experiments were run to determine the ultrasonic acoustic backscatter characteristics of surf zone bubbles. Bulk void fraction and optical sizing methods were explored to develop a means of measuring bubble populations produced in the laboratory for calibration of the backscattered energy received by the CASP system in the presence of bubbles.*

ACCESSION NUMBER: ADA305430

McKinney, C. **International Symposium on Mine Warfare Vessels and Systems Held at London, England on 12-15 June 1984.** Conference rept. Office of Naval Research, London (England): 19 Jul 84. 15p.

*ABSTRACT: The International Symposium on Mine Warfare Vessels and Systems was held in London from 12 through 15 June 1984. This report discusses presentations on platforms and propulsion equipment for mine countermeasures systems, and minehunting systems and components.*

ACCESSION NUMBER: ADA146408

McShane, S.L. **Where Are My Submarines.** Final rept. Naval War Coll., Newport, RI: 13 Feb 95. 24p.

*ABSTRACT: The unique operational capabilities and employment advantages inherent to the U.S. attack submarine force provide a cost effective and highly powerful platform to the Unified Commanders for shaping their respective theaters across the entire range of military operations. Attack submarines (SSNs) offer considerable operational flexibility and firepower while fulfilling many roles including forward presence, indication and warning, anti-submarine, anti-surface, strike, mine laying, mine countermeasure and special forces insertion. Preemptive conventional strike capability is considerably more credible in an environment where the threat of nuclear weapon employment has diminished. Therefore, the SSN's formidable conventional strike capability presents a powerful force to be reckoned with by any potential adversary. Moreover, the SSN's stealth, mobility, endurance and readiness enhance its offensive potential, making the SSN uniquely the platform of choice in most forward deployed scenarios. During the Cold War our senior military leaders, when confronted with a regional crisis, would ask where their carriers were... I would argue that in today's post Cold War era, they should be asking where their submarines are.*

ACCESSION NUMBER: ADA293261

McWhite, Peter B and H. Donald Ratliff. **Defending a Logistics System Under Mining Attack.** Center for Naval Analyses, Arlington, VA: Aug 1976. 35p.

*ABSTRACT: A fundamental problem in mine warfare defense is to deploy mine countermeasure resources and to route supplies so that shipping losses are minimized. The shipping losses at a port are a function of the mining attack, the quantity and duration of countermeasure efforts, and the amount shipped from the port. Models and solution algorithms are developed in this paper to optimally apportion scarce countermeasure resources when the quantity of supplies shipped out of each port is not subject to control and for the case when one can control both flow routing and countermeasures deployment. When the shipping schedule is fixed, the models are special cases of minimum cost network flow problems. For the more general problem, an enumeration algorithm is developed and computational results presented.*

ACCESSION NUMBER: ADA030454

**Naval Surface Warfare Center Dahlgren Division. Technical Digest. Ship Defense Technology.** September 1994. Naval Surface Warfare Center, Dahlgren, VA. Dahlgren Div.: Sep 94. 155p.

*ABSTRACT: CONTENTS - Guest Editor's Introduction: Towards A Proactive Surface Force-The Role of Ship Defense in the 21st Century; Short-Range Anti-air Warfare Missile Systems Engineering; Integrated Interior Communications and Control-Engineering Validation of a Total Ship Architecture; Tactical Ballistic Missiles Trajectory State and Error Covariance Propagation; Superconducting Magnetic Sensors for Mine Countermeasures; Managing the Dynamics of the Electromagnetic Environment to Maximize Combat System Performance Electronic Warfare in Ship Defense Signal Simulators Used in Deception Nonlinear Least-Squares Estimation in Naval Gun Fire Control Robust Flight Control for Surface-Launched Tactical Missiles Water Barrier Ship Self-Defense Concept.*

ACCESSION NUMBER: ADA294929

**NAVY-21 UPDATE: Implications of Advancing Technology for Naval Operations in the Twenty-First Century.** National Research Council, Washington, DC: 1993. 70p.

*ABSTRACT: In the summer of 1988, the National Research Council issued the Naval Studies Board's report Implications of Advancing Technology for Naval Operations in the Twenty-First Century, known as Navy 21 (National Academy Press, Washington, D.C.). The study had been carried out over the previous 18 months, at the U.S. Navy's request. In the terms of reference for that study, the Chief of Naval Operations (CNO) asked how future technological trends might change Navy force structure, what the impact of those changes on U.S. maritime strategy might be, and how the Soviet Union might respond. The study involved 188 civilian experts and 22 Navy and Marine Corps liaison officers. It was informally agreed when the study was completed that it represented a broad and solid base from which to continue to examine the Navy's future problems, and that it would be useful to reexamine the position of the Navy and the country every 5 to 10 years, to see what trends had been reinforced, what trends had changed, and how the differences would affect the Navy from then on. The purpose of this report is to revisit the 1988 Navy-21 forecast of Navy trends and technological opportunities in light of world events in the 5-year period from 1988 to 1993. A few major themes emerged from this update of the 1988 Navy-21 report, as indicated: (1) Orienting to a New Environment; (2) The Information War Is Crucial: Intelligence, Combat Information Network, Battle Management; (3) Air and Surface Forces: A New Balance-Precision Strike, Focused Defense; (4) Amphibious Forces: Enhanced Force Projection Ashore; Countermine Critical; (5) Undersea Forces: Other Than Strategic Forces, Shore Oriented; and (6) New Approaches to Managing Technology and People Issues for Urgent Navy Attention.*

ACCESSION NUMBER: ADA306545

**Neto, R. and J. Augusto. Mine Search Algorithm for the Naval Postgraduate School Autonomous Underwater Vehicle.** Master's thesis. Naval Postgraduate School, Monterey, CA: Dec 94. 102p.

*ABSTRACT: This thesis develops, implements and tests a mine search algorithm for the Naval Postgraduate School Autonomous Underwater Vehicle (Phoenix). The vehicle is 72 inches long and displaces 400 pounds. Its maneuvers are performed using two propellers and four thrusters. It contains two embedded computer systems. The algorithm directs the autonomous search of a specified area mapping all obstacles and computing an estimate of the cumulative probability of detection. The algorithm uses no prior knowledge of the terrain or the location of mines. The algorithm, which is written in Lisp, can execute on the vehicle's computer systems. Along with the search and mapping capabilities, the algorithm executes obstacle avoidance. The algorithm is tested in several simulated scenarios with different placement of mines and obstacles; the amount of resources used and the fraction of the area searched is computed. A similar algorithm that uses hill-climbing search is implemented for comparison. In all cases, the newly developed algorithm performed equal or better than the one that uses hill-climbing.*

ACCESSION NUMBER: ADA290024

**Niemann, K.P. Mine Warfare Forces.** Naval Intelligence Support Center, Washington, DC. Translation Div.: 25 Apr 83. 10p.

[Trans. of Soldat und Technik, D 6323 E, n.p., v2 p62-67 Feb 83.]

*ABSTRACT: No abstract available.*

ACCESSION NUMBER: ADA128971

**Perraut, R.E. Gulf War Lessons Learned by Iraq (A.K.A. How to Fight the United States and Win).** Final rept. Naval War Coll., Newport, RI: 17 Jun 94. 37p.

*ABSTRACT: The invasion of Kuwait was undertaken by Saddam Hussein to solve his severe economic problems, to fix a historical claim, to secure access to the Persian Gulf, and to increase his personal power and status*



*within the Middle East. Iraq's campaign was built on some flawed assumptions and unraveled in execution. In a future campaign to invade Kuwait, Iraq could apply what it learned from the Gulf War. There are two main approaches: what Iraq could do to keep the United States out of the Gulf and how to fight deployed U.S. forces. Keeping U.S. forces out of Saudi Arabia would greatly hamper U.S. efforts to liberate Kuwait. If U.S. forces are deployed to the region, Iraq has three options. First, Iraq could fight the United States nose-to-nose and seek a negotiated settlement before the United States overwhelms the Iraqi forces. Secondly, Iraq could attempt to bloody the U.S. nose with attacks to inflict massive casualties in order to undermine the U.S. and Saudi Arabia's will to continue military actions against Iraq. And thirdly, Iraq could immediately seek a negotiated settlement hoping to keep at least part of Kuwait. Based on these approaches and options, USCENTCOM faces many serious planning challenges for the next Gulf War in terms of responding, deploying, and fighting. Gulf War, Desert Storm, WMD, Sea mines, Coalition, Saudi Arabia, Kuwait, Iraq, Saddam, USCENTCOM.*

ACCESSION NUMBER: ADA283409

**Preston, J.M. Coordinates as determined by side-scan sonar: Theory and applications.**

DREP technical memorandum no. 88-02. Defence Research Establishment Pacific, Victoria (British Columbia): c1988. 48p.

*ABSTRACT: A central issue in minehunting is the accuracy with which the coordinates of a mine-like object can be determined. This survey process is done in stages, first locating the ship, then locating the object with respect to the sonar, then determining the vector between the ship and the towfish if side-scan sonar is used. This report derives the equations which determine the chart coordinates of a bottom object from the 14 variables describing the side-scan sonar deployment which imaged that object. Improvements in the accuracy of the coordinates which could be achieved by improving the accuracy with which any variable is measured are then predicted. Coordinate data acquired during MINEX 87 is used to calculate the unmeasured angular variables which characterized that deployment.*

ACCESSION NUMBER: MIC910014

**Pritchard, L.L. Distributed Computing Environment for Mine Warfare Command.** Master's thesis. Naval Postgraduate School, Monterey, CA: Jun 93. 108p.

*ABSTRACT: The Mine Warfare Command in Charleston, South Carolina has been converting its information systems architecture from a centralized mainframe based system to a decentralized network of personal computers over the past several years. This thesis analyzes the progress of the evolution as of May of 1992. The building blocks of a distributed architecture are discussed in relation to the choices the Mine Warfare Command has made to date. Areas that need further attention and development are discussed based on the research findings. Finally, recommendation for future planning, procurement and improvements to the system are made. Lessons learned by this command during the conversion to a networked system are described.*

ACCESSION NUMBER: ADA268799

**Proceedings of the Ship Control Systems Symposium (7th) Held in Bath, England on 24-27 September 1981.** Volume 1. Ministry of Defence, Bath (England): 27 Sep 84. 115p.

[See also Volume 2, AD-A211 134.]

*ABSTRACT: Contents: Digital progress in the Royal Navy; US Navy control systems overview; Machinery control initiatives -- A Canadian perspective; Ship automation -- A Dutch view on practice and progress; Digital control and surveillance system for the M-Class frigate of the Royal Netherlands Navy; Propulsion control in the Swedish M80 Class Mine Countermeasures Ships; Practical experience in the application of microprocessors to machinery control and surveillance; Multivariable adaptive control of ships motions; A classical approach to a microprocessor based PID Autopilot design; Model tests and full-scale trials with a rudder-roll stabilisation system.*

ACCESSION NUMBER: ADA211133

Read, C.H. **Hydrographic Survey Requirements System (HYSUR)**. Final rept. Defense Mapping Agency Hydrographic/Topographic Center, Washington, DC.: Jun 83. 9p.

*ABSTRACT: The Defense Mapping Agency (DMA) has no automated system with which to determine the survey precedence of the 8.2 million square nautical miles of worldwide coastal areas which require hydrographic surveying. In response to this vast requirement, the DMA Hydrographic/Topographic Center (HTC) is developing the Hydrographic Survey Requirements System (HYSUR). This software system will enable managers to make timely, systematic decisions, thereby enhancing the utility of the Naval Oceanographic Office (NAVOCEANO) survey vessels. This report discusses the practical applications of this system which will identify hydrographic data deficiency areas; establish a rank order for required survey areas considering economic, political, military, and physical factors; provide an alternative planning capability to answer management-level questions; and produce survey program plans based on the results of the ranking procedures, available resources, and estimated cost. (Author)*

ACCESSION NUMBER: ADA131115

**Report of the Mine Warfare Study Group. Volume 8. The SWATH as an MCM (Mine Countermeasures) Platform.** National Academy of Sciences-National Research Council, Washington, DC.: Sep 82. 80p.

*ABSTRACT: The following are among the Task Groups findings: (1) A SWATH hull form displacing 33 to 54 t appears to have excellent seaworthiness characteristics for the inshore MCM mission while housing ample payload for minehunting with limited neutralization. (2) The seakeeping characteristics predicted for the SWATH hull form will permit a hull mounted sidelooking sonar option with minimum yaw compensation and no roll and pitch compensation. (3) The results of computer predictions of the motions of the two proposed SWATH designs show that, when suitably averaged for all headings, and when operating at 6 kt in a state 3 sea the roll angle amplitude for all designs will be less than 2 deg; the heave amplitude at the LCG will be approximately 2 ft; and the LCG accelerations approximately 0.04 g. These small motions and accelerations provide a comfortable working environment for crew and instrumentation. and (4) The comparative seaworthiness of a monohull, ASR Catamaran form, and MCM SWATH in the same environment are presented. The motions and accelerations of the SWATH hulls were substantially less than those for monohull and catamaran.*

ACCESSION NUMBER: ADA133442

Ricci, J.J. **Preliminary Risk Assessment of the Remote Minehunting System (RMS)**. Naval Sea Systems Command, Washington, DC: 23 Oct 91. 32p.

*ABSTRACT: This Risk Assessment of the RMS rates the risks associated with developing the sub-systems and components of the RMS. The risks are identified as low, medium, and high level so that high risk may be provided the highest resource priority.*

ACCESSION NUMBER: ADA255805

Richardson, M.D. **Coastal Benthic Boundary Layer Special Research Program. Program Direction and Workshop Recommendations**. Final rept. Performer: Naval Oceanographic and Atmospheric Research Lab., Stennis Space Center, MS: Aug 92. 164p.

*ABSTRACT: A 5-year Special Research Program (SRP) has been established at the Naval Research Laboratory that addresses the physical characterization and modeling of benthic boundary layer processes and the subsequent impact of these processes on the seafloor properties that affect mine countermeasure operations. This special project outlines the SRP scientific program and reviews the results of the four*

workshops convened to establish scientific priorities. Workshop participants agreed that sediment structure provides the common perspective: to quantitatively model relationships among sediment physical properties; to quantify the effects of environmental processes on sediment properties; and to model sediment behavior (acoustic, electrical, and mechanical). Hypotheses based on quantitative physical models that incorporate three-dimensional sediment structure will be tested by a series of field experiments at coastal locations where differing environmental processes dominate sediment structure. These experiments stress the role of sediment structure in determining high-frequency acoustic phenomena such as scattering, penetration, and propagation, as well as the physical relationships between remotely sensed acoustic properties and mechanical strength parameters.

ACCESSION NUMBER: ADA256608

Richardson, M.D. et al. **Environmental Support for High Frequency Acoustic Measurements at NOSC Oceanographic Tower, 26 April-7 May 1982. Part 1. Sediment Geoacoustic Properties.** Final rept. 26 Apr-7 May 82. Naval Ocean Research and Development Activity, NSTL Station, MS: Jun 83. 70p.

*ABSTRACT: This is the first of a four-volume report on environmental support for a high frequency acoustic experiment conducted near the Naval Ocean Systems Center (NOSC) Oceanographic Tower, one mile off the California coast near San Diego, 26 Apr-7 May 1982. The objective was to provide improved shallow-water acoustic models required for development of advanced mine-hunting sonar systems. This report, presents, sediment geoacoustic measurements made concurrently with backscatter measurements for the NOSC Tower Experiment. Two sediment types were evident from visual observation and from laboratory analysis of sediment geoacoustic properties. The sediments closest to the transmit-receive tripod were coarse sands with higher compressional wave velocity and lower attenuation and impedance values than those of fine sands surrounding the target spheres. Sediment compressional wave velocity and attenuation increased with depth in the sediment, probably as a results of a decrease in porosity due to compaction and packing. Surficial gradients in sediment geoacoustic properties may be important factors in the prediction of high frequency bottom reverberation.*

ACCESSION NUMBER: ADB076818

Russell, B.F. **Operational Theater Mine Countermeasures Plan: More than a Navy Problem.** Monograph. Army Command and General Staff Coll., Fort Leavenworth, KS: 14 May 95. 54p.

*ABSTRACT: This monograph finds that theater commanders, with vital maritime choke points/canals in their theater, should have their J-5 planners develop and integrate a comprehensive counter mine plan into the theater's campaign plans. In the past, regional mine countermeasure's plans have been viewed as a Navy responsibility. However, today's theater commander may face short regional conflict warning times which require the conduct of mine countermeasures (MCM) operations before Naval MCM planners and their forces (ships and aircraft) can arrive in theater. Using joint theater forces (Army, Air Force, Special Operations Forces, Navy, and Space assets), the theater commander can conduct MCM operations to prevent mines from going in the water or to detect and record locations of enemy mine laying operations, reducing greatly the time required for counter mine operations by Naval MCM ships and aircraft upon their in-theater arrival. The coordination and allocation of Joint theater forces to conduct MCM operations requires a theater commander to plan and prepare for mining threats long before the first enemy sea mine enters the water. This monograph uses the Secretary of Defense's October 1993 Report on the Bottom-Up Review as a reference, to identify real world MCM missions from a scenario that involves two nearly simultaneous conflicts in the Korean and Persian Gulf regions. To execute counter mine missions in these theaters, the J-5 planing staffs must develop MCM plans for the theater commander. This monograph takes the J-3 planner through the required building blocks to develop an effective theater MCM plan. The monograph describes the North Korean and Iraqi mining threats, past and present, to*

*include mine types, mine delivery platforms, and possible battlespace areas that could be effectively mined. The strengths and weaknesses of U.S. MCM forces, ships and aircraft.*

ACCESSION NUMBER: ADA301152

Ryan, P.J. and C.J. Akenfelds. **Effect of Ship Motion on Ship Magnetic Signature.** Materials Research Labs., Ascot Vale (Australia): May 88. 33p.

*ABSTRACT: The effects of roll, pitch and yaw motions on a ship's magnetic signature are investigated. These three modes of rotary motion, each simple harmonic, are treated as uncoupled and a dipole model representation is used to describe the ship's magnetization. Signatures are computed for a model ship assumed, for simplicity, to be bearing due magnetic North and compared with the steady-state signatures (for no rotary motion). Oscillatory magnetic field components result from these ship motions which decrease in significance, compared to the steady-state fields, as the observation point is moved further away from the ship's passage. These field deviations decrease more rapidly with a beam displacement than with depth. Variation with ship speed is more complicated and depends critically on the values assigned for the amplitudes, frequencies, and relative phases of the three modes of motion. In high sea states the magnetic signatures can vary considerably from those in calm seas with implications for magnetic-influence mine actuation*

ACCESSION NUMBER: ADA200045

Savage, K.D. and R. W. Meredith. **Modeled High-Frequency Acoustic Backscattered Levels from Range-Independent and Simplistic Range-Dependent Sand Bottoms.** Final rept. Naval Research Lab. Detachment, Stennis Space Center, MS: 21 Feb 96. 17p.

*ABSTRACT: Results investigating the effects of variable bottom composition on modeled high-frequency backscattered levels are presented for a typical shallow-water, variable bottom (range-dependent) environment. The modeled environment consisted of a single sound speed profile, a flat sea bottom with range-dependent bottom composition, and a smooth, flat sea surface. Coarse-and fine-grained sandy areas were partitioned in range to create range dependence. Bottom backscattering and reflection loss for each partition were obtained from a recent University of Texas high-frequency ocean bottom backscatter model. Maximum differences of S dB were discernible between the fine- coarse-fine sand bottom and a range-independent fine-sand bottom for ranges <500 m. The trend and structure of the backscattered levels were nearly identical for both bottom types. In all cases, surface reverberation had a strong impact on the backscattered levels, trends, and structures.*

ACCESSION NUMBER: ADA305987

Scala, P.A. **U.S. Logistics Vulnerability: Major Regional Conflict with Iran.** Naval War Coll., Newport, RI. Dept. of Operations: 16 May 94. 45p.

*ABSTRACT: The United States has chosen to emphasize a power projection role for its military. This capability proved itself during Operation Desert Storm. However, Desert Storm also pointed out a significant weakness. To stop the U.S. military, an enemy need only interrupt the logistics chain. How well does the U.S. guard its Logistic ability. This paper addresses the possibility that a dedicated, marginally capable opponent could do significant damage to the U.S. Logistics system. This in turn could cause the U.S. to abandon or change national priorities*

ACCESSION NUMBER: ADA283377

Schnell, D.A. **Stormy Waters: Technology, Sea Control and Regional Warfare.** Master's thesis. Naval Postgraduate School, Monterey, CA: Jun 94. 165p.

*ABSTRACT: An important aspect of the current strategic calculus is the diffusion of technology and proliferation of advanced weaponry, particularly naval weapon systems. This is of particular concern for the United*

*States' Navy, historically the first on-scene and the likely target of any initial challenge to our presence. The Navy's new war-fighting doctrine, '...From the Sea' focuses the Navy on these challenges. However, it has not been complimented by the necessary recapitalization and procurement to make it truly operational. To bridge the gap between the doctrinal concepts of '...From the Sea' and current capabilities, the Navy must improve its ability to exercise sea control and dominate the littoral battlespace. This will require tough procurement choices and significant investments in mine warfare, advanced military aircraft and state-of-the-art C4I systems. It may also be necessary for the Navy to postpone certain improvements or abandon certain missions in order to refocus and selectively modernize elements of the fleet.*

ACCESSION NUMBER: ADA283945

Schroeder, E.A. and G. Green. **Finite Element Shock Analysis of a Cryogenic Refrigerator.** Interim rept. Jan-Aug 93. Naval Surface Warfare Center Carderock Div., Bethesda, MD. Ship Systems and Programs Directorate: Dec 94. 30p.

*ABSTRACT: Two-stage Gifford-McMahon refrigerators are candidates for use in cooling superconducting magnets for naval applications in mine countermeasures and electric-drive propulsion for ships. For these applications, the refrigerators can be expected to undergo shock and vibration due to the motion of the platform on which they are mounted and to explosions of nearby mines. If the refrigerator is to continue operating effectively, the cylinder walls must not be permanently deformed when subjected to shock loads, and therefore stresses in the walls must not approach the elastic limit of the wall material. The stress in the cylinder walls due to specified shocks was determined by an axisymmetric finite element shock analyses of the two-stage cylinder and displacer assembly. For this analysis, it was assumed that the displacers were at the bottom of their stroke and each was resting on the bottom of its cylinder. Constant horizontal and vertical accelerations of 100 g and a time-dependent acceleration with maximum amplitude of 103 g were applied to the model. The analysis for the vertical shock loading produced a maximum stress of 36.7 MPa, 5 percent of yield for the 304-type stainless steel used for the cylinder walls.*

ACCESSION NUMBER: ADA294278

**Semi-annual project review of the Experimental Diving Unit, November 1993 to April 1994.** Interim research report no. DCIEM no. 94-30. Defence and Civil Inst. of Environmental Medicine, Downsview (Ontario): c1994. 47p.

*ABSTRACT: Description of 12 projects of the Experimental Diving Unit conducted from November 1993 to April 1994. Major projects include the development of a freeze-proof regulator, and decompression tables for the Canadian Underwater Mine-countermeasures Apparatus. For each project, information is given on defence relevance, description of the project, progress, and projections. A task description sheet is also included for each.*

ACCESSION NUMBER: MIC940726

Shen, J.W. **Finite Difference Methods Applied to Biot Theory in Porous Medium.** Master's thesis. Naval Postgraduate School, Monterey, CA.: Sep 95. 55p.

*ABSTRACT: Finite difference methods are used to solve the Biot equations for wave propagation in a porous medium. The computational domain is a two dimensional grid of uniform spacing where truncation of the grid on all sides is accomplished by applying homogeneous Dirichlet boundary conditions. The difference method is second order in space and time, and is seen to accurately predict phase speeds of the primary compressional and shear waves.*

ACCESSION NUMBER: ADA306214

Spieker, H. **Mine Countermeasures.** Naval Intelligence Support Center, Washington, DC.  
Translation Div.: 25 Apr 83. 13p. [Trans. of Soldat und Technik, D 6323 E (Germany,  
F.R.) v2 p72-78 Feb 83.]

*ABSTRACT: No abstract available.*

ACCESSION NUMBER: ADA129354

Steel, N., M. Philips and G. Meagher. **Interactive Neural Network System for Acoustic  
Signal Classification.** Final rept. 1 Sep 89-28 Feb 90. Advanced Resource Development  
Corp., Columbia, MD.: 28 Feb 90. 123p.

*ABSTRACT: The objectives of this project was to develop an understanding of the effect of neural networks, implemented in interactive systems, on sonar operators and other naval personnel. Specifically, the project called for the development of a prototype system, employing neural networks to test the effect of interactive (man-in-the-loop) operations. ARD developed such a system which is used to classify time domain signals generated from the insonification of an underwater mine-like target. The system converts the time domain signals to frequency domain and frequency over time (spectrograms) and displays the signals at the users' request in all three formats. A time windowing function is also provided to allow the user to closely inspect specific portions of the time domain signal. In addition, a neural network system classifies the signal according to three parameters: shell thickness, interior content and angle of insonification. Results have shown that most users exhibit a large bias towards the use of the neural network analysis because of their highly accurate classification. Future work will concentrate on the integration of neural network tools into existing systems in real-world situations. A better understanding of the human-network interactions will be gained when the ability of the networks to classify real world signals is decreased due to the complex geometries of actual mines and environmental effects on the sonar returns (thermoclines, shallow water, surface returns).*

ACCESSION NUMBER: ADA219278

Strain, P.M. **Amphibious Operations in the 21st Century: A Viable Forced-Entry  
Capability for The Operational Commander.** Army Command and General Staff  
Coll., Fort Leavenworth, KS. School of Advanced Military Studies: 14 May 93. 67p.

*ABSTRACT: Since the demise of the former Soviet Union, the world has witnessed greater international turmoil, aggression, and conflict. The possibility of a global conflict is minimal, but the opportunities for United States involvement in regional conflicts has increased in order to protect its vital interests. The current reductions in armed forces and forward deployment of units require the maintenance of a strong power projection and forced-entry capability. The two form of force-entry operations available to the operational commander are amphibious and airborne operations. The requirement to conduct amphibious forced-entry operations remains valid. The United States is a maritime nation and the majority of its interests lie close to the sea. However, the reduction in amphibious shipping, naval surface fire support, and mine-countermine capabilities, and the proliferation of advanced technology and weapons to potential third world foes, calls to question the ability of the United States to conduct traditional amphibious forced-entry operations. To remain viable in a much more lethal environment, amphibious operations must be conducted from a maneuver warfare perspective.*

ACCESSION NUMBER: ADA274020

**. Infrared Reflectance Measurements of Replica Mines and Reference Targets.**

Memorandum rept. Defence Research Establishment Suffield, Ralston (Alberta).: Feb  
89. 49p.

*ABSTRACT: Remote minefield detection (RMD) can be performed by mounting downward-looking sensors on airborne platforms such as remotely-piloted vehicles (RPVs). Scatterable mines lying on the surface of the*

ground may be detected using a carbon-dioxide laser mounted on the RPV as a source of thermal infrared radiation and by measuring the reflected signals to create an image of the terrain below. Such an active infrared system is capable of operating covertly at all times of the day or night and makes use of much of the technology found in current passive infrared sensors (ie. forward-looking infrared imagers, FLIRs, on military aircraft, ground vehicles, and ships). This report presents reflectance data on a number of replica mines which have been found to be specular (mirror-like) at thermal IR wavelengths. The measurements of the replica mines and a number of reference materials were made in a laser laboratory, and retro-reflectivity data for each target are presented graphically as a function of the angle at which the IR laser beam hit the target surface. The fact that the replica mines are specular means that the RMD sensor must be downward-looking and only those mines within a fairly small angular field-of-view will give significantly large reflected signals.

ACCESSION NUMBER: ADA209084

Stuart, G.C. **Remote Minefield Detection Using Infrared Laser Radar.** Memorandum rept. Defence Research Establishment Suffield, Ralston (Alberta): Nov 88. 131p.

*ABSTRACT: High-resolution infrared laser radars are shown to be effective sensors for use in remote minefield detection (RMD). The theoretical aspects and practical limitations of imaging laser radars are discussed and the conceptual designs of two airborne carbon-dioxide laser radars are presented. A design which uses direct detection and a linear-array detector is shown to be superior to one using heterodyne detection and a single-element detector. Countermeasures to active infrared RMD systems are discussed and suggestions made for further study.*

ACCESSION NUMBER: ADA202206

Thomas, M.J. **Missing from the Toolbox: Preemptive Strike.** Final rept. Naval War Coll., Newport, RI: 16 May 95. 21p.

*ABSTRACT: The national security strategy of the United States requires the military to prosecute two nearly simultaneous major regional conflicts. This is similar to the Israeli asymmetric strategy of fighting one enemy while holding another. Once the first is defeated, Israeli attention focuses on defeating the second enemy. To make the strategy work, the Israelis pre-emptively strike their enemies to gain the initiative. American national strategy does not include a provision for preemptive action. Past American wars, including the Persian Gulf War, relied on a significant build-up of regional combat power before taking offensive action. An enemy might conclude that the best way to fight the United States is to isolate the region from the introduction of U.S. forces. A combination of sea mines and an anti-air lift plan could keep U.S. forces from a theater. Because sea mining is likely to be part of an initial enemy action, preempting sea mining operations is as important as gaining air superiority. Once the sea mines are planted, will take significant time to conduct mine counter-measures operations. An enemy with a clearly defined objective and good diplomatic initiative could use the time that the U.S. was isolated from the theater to gain a peace on its terms.*

ACCESSION NUMBER: ADA297956

Tooma, S.G. and M. D. Richardson. **Key West Campaign University, Government Laboratory, International Effort Focuses on Coastal Benthic Boundary Layer, Combining Basic, Applied Programs.** Journal article. Naval Research Lab. Detachment, Stennis Space Center, MS: Jun 95. 10p.

*ABSTRACT: During February 1995, four research vessels (WFS Planet, R/Vs Seward Johnson, Pelican, and Seaward Explorer) and 115 scientists and technicians from five nations mounted a major scientific campaign in waters off the western Florida Keys. Experiments focused on the shallow-water, carbonate, sedimentary environments in the vicinity of the Marquesas Keys and the Dry Tortugas in recognition that*

*naval operations have shifted focus to nearshore coastal operations that emphasize mine countermeasures (MCM). The Florida Keys are the only U.S. waters analogous to the shallow-water, tropical, carbonate settings that are becoming increasingly important to naval operations (e.g., Persian Gulf) and where the biogeochemical processes that are typical of those carbonate environments can be studied.*

ACCESSION NUMBER: ADA297997

U.S. General Accounting Office. **Mine Warfare: Ingleside, Texas, may not be the Best Location for Consolidation.** General Accounting Office, Washington, DC. National Security and International Affairs Div.: Dec 91. 8p.

*ABSTRACT: This report concludes that the Navy's decision to homeport its mine countermeasures ships at Ingleside will necessitate the expenditure of significant additional funds to accommodate the ships and consolidate other mine warfare forces. Ingleside's distance from the Atlantic and Pacific Fleets could also increase operational costs and hamper efforts to better integrate mine warfare forces into overall Navy operations. Further, we believe that the Navy has not adequately addressed these concerns of sufficiently analyzed the potential benefits of locating mine warfare forces at a base on both the East and West Coasts.*

REPORT NUMBER: GAO/NSIAD-92-63

ACCESSION NUMBER: ADA244141

U.S. General Accounting Office. **Navy Mine Warfare: Budget Realignment Can Help Improve Countermining Capabilities.** General Accounting Office, Washington, DC. National Security and International Affairs Div.: 13 Mar 96. 53p.

*ABSTRACT: Operation Desert Storm highlighted major weaknesses in the Navy's capability to detect and disarm enemy mines. The Navy possessed only a very limited capability at that time to conduct mine countermeasures at various water depths. In addition, two Navy warships, the U.S.S. Princeton and the U.S.S. Thpoli, both struck Thaqi mines in open waters in the Persian Gulf. The combined damage to the two ships, which totaled about \$21.6 million, was caused by two mines—one estimated to cost \$10,000 and the other about \$1,500. The Navy has since made a number of organizational changes and initiated several research and development projects to address the weaknesses in its mine countermeasures program. At the request of the Chairman, Subcommittee on Military Research and Development, House Committee on National Security, GAO examined the steps the Navy is taking to ensure a viable, effective naval force that will be ready to conduct mine countermeasures in two nearly simultaneous major regional conflicts. Specifically, GAO evaluated the (1) status of the Navy's research and development projects, (2) readiness of the Navy's on-hand mine countermeasures assets, and (3) match between the Navy's planned and on-hand mine countermeasures assets and its mine countermeasures requirements.*

REPORT NUMBER: GAO/NSIAD-96-104

ACCESSION NUMBER: ADA305721

U.S. General Accounting Office. **Navy Ships: Lessons of Prior Programs May Reduce New Attack Submarine Cost Increases and Delays.** General Accounting Office, Washington, DC. National Security and International Affairs Div.: Oct 94. 19p.

*ABSTRACT: The Navy's plans to incorporate lessons learned from prior submarine programs, particularly the Seawolf SSN-21 program into the design and construction of the NSSN, a new class of nuclear-powered attack submarine were assessed. Several factors make the NSSN both an excellent opportunity and a challenge for the Navy to control acquisition costs and to improve the quality of the design and construction process. These factors are (1) a reduced antisubmarine warfare threat; (2) the U.S. defense budget, which has been more tightly constrained each year; and (3) the early stages of the NSSN acquisition cycle, which allow an agency to apply lessons of past programs to future programs. The NSSN's missions include battlegroup support, covert strike warfare, covert intelligence, special warfare,*



*covert mine warfare, antisubmarine warfare, and antisurface warfare operating in both open ocean and littoral (coastal) areas.*

GAO/NSIAD-95-4

ACCESSION NUMBER: ADA285905

**U. S. Naval Forces, Vietnam Monthly Historical Supplement for January 1967.** Naval Forces, Vietnam: 20 Mar 67. 110p.

*ABSTRACT: No abstract available.*

ACCESSION NUMBER: ADA953681

**U.S. Naval Forces, Vietnam Monthly Historical Supplement for March 1967.** Naval Forces, Vietnam: 29 May 67. 121p.

*ABSTRACT: No abstract available.*

ACCESSION NUMBER: ADA953640

**U.S. Naval Forces, Vietnam Monthly Historical Supplement for April 1967.** Naval Forces, Vietnam: 3 Jul 67. 104p.

*ABSTRACT: No abstract available.*

ACCESSION NUMBER: ADA953639

**U.S. Naval Forces, Vietnam Monthly Historical Summary for May 1967.** Naval Forces, Vietnam: 5 Jul 67. 51p.

*ABSTRACT: No abstract available.*

ACCESSION NUMBER: ADA953638

**U.S. Naval Forces, Vietnam Monthly Historical Supplement for December 1967.** Naval Forces, Vietnam: 7 May 68. 167p.

*ABSTRACT: No abstract available.*

ACCESSION NUMBER: ADA953641

**U.S. Naval Forces, Vietnam Monthly Historical Supplement for June 1968.** Naval Forces, Vietnam, : 18 Feb 69. 185p.

*ABSTRACT: No abstract available.*

ACCESSION NUMBER: ADA953598

**U.S. Naval Forces, Vietnam Monthly Historical Summary for January 1970.** Naval Forces, Vietnam: 10 Mar 70. 197p.

*ABSTRACT: No abstract available.*

ACCESSION NUMBER: ADA953634

**U.S. Naval Forces, Vietnam Monthly Historical Summary for April 1970.** Naval Forces, Vietnam: 13 Jun 70. 138p.

*ABSTRACT: No abstract available.*

ACCESSION NUMBER: ADA953608

**U.S. Naval Forces, Vietnam Monthly Historical Summary for June 1970.** Naval Forces,  
Vietnam: 17 Sep 70. 111p.  
*ABSTRACT: No abstract available.*  
ACCESSION NUMBER: ADA953607

**U.S. Naval Forces, Vietnam Monthly Historical Summary for July 1970.** Naval Forces,  
Vietnam: 22 Sep 70. 75p.  
*ABSTRACT: No abstract available.*  
ACCESSION NUMBER: ADA953606

**U.S. Naval Forces, Vietnam Monthly Historical Summary for August 1970.** Naval Forces,  
Vietnam,; 6 Oct 70. 90p.  
*ABSTRACT: No abstract available.*  
ACCESSION NUMBER: ADA953605

**U.S. Naval Forces, Vietnam Monthly Historical Summary for September 1970.** Naval  
Forces, Vietnam,; 8 Nov 70. 87p.  
*ABSTRACT: No abstract available.*  
ACCESSION NUMBER: ADA953604

**U.S. Naval Forces, Vietnam Monthly Historical Summary for November 1970.** Naval  
Forces, Vietnam.: 9 Feb 71. 94p.  
*ABSTRACT: No abstract available.*  
ACCESSION NUMBER: ADA953596

**U.S. Naval Forces, Vietnam Monthly Historical Summary for September 1971.** Naval  
Forces, Vietnam: 23 Nov 71. 106p.  
*ABSTRACT: No abstract available.*  
ACCESSION NUMBER: ADA953636

Van Buren, A.L. **Near-Field Calibration Arrays for Acoustic Wavefield Determination.  
(Reannouncement with New Availability Information).** Naval Research Lab., Orlando,  
FL. Underwater Sound Reference Detachment: Feb 92. 6p.

*ABSTRACT: This paper describes the use of the near-field calibration array (NFCA) to determine the far-field properties of acoustic receivers and projectors by measurements made in their near-field. When used as a projector to evaluate receivers, the NFCA produces a nearly uniform plane wave over a large volume in its near-field and over a large frequency range. When used as a receiver to evaluate projectors, the NFCA becomes a plane-wave filter for acoustic radiation (or target scattering) originating from within the plane-wave volume. The basis of the NFCA is a reciprocity principle. Numerical implementation of this principle provides the complex weighting factors to be used as shading coefficients for the individual elements in the NFCA. The original Trott NFCA's W.J. Trott, J. Scous. Soc. Am. Vol. 36, pp. 1557-1568, Aug. 1964 were planar. This paper describes the subsequent extension of the concept to a cylindrical NFCA suitable for determining the azimuthal far-field pattern and a spherical NFCA that allows a determination of the entire three-dimensional far-field pattern.*

ACCESSION NUMBER: ADA251462

**Wallace, R.J. Mine Warfare: Its Implication for the Future of Amphibious Operations.**

Research rept. Aug 92-Apr 93. Industrial Coll. of the Armed Forces, Washington, DC: Apr 93. 31p.

*ABSTRACT: The purpose of this research paper is to explain the importance of amphibious operations in relation to the President's National Security Strategy. The barrier that may hinder our success in future regional conflicts is the amphibious mine. All Third World countries have access to these mines, which can destroy shipping lines of communications and battle plans. In today's environment, with the shrinking defense budget, I stress the requirement to continue funding mine countermeasures' programs. Funding these programs is essential to maintaining our National Security policies throughout the globe.*

ACCESSION NUMBER: ADA276771

**Wallander, B.L. Electronic Countermeasures (ECM) and Acoustic Countermeasures Supported Protection for Merchant Ships against SSM/ASM Missiles and Mines.**

Masters's thesis. Naval Postgraduate School, Monterey, CA.: Dec 89. 195p.

*ABSTRACT: The necessity for merchant ship self protection has become more and more obvious during recent years. This thesis will investigate the threat (missiles and mines) and associated counter-measures that might be installed to provide a reasonable degree of protection. The results indicate that it is possible to get protection against a sea-skimming missile with a combination of ECM and ESM deployed aboard the ship. For protection against the mine threat, a sonar is designed in order to give the ship enough warning time to make an avoiding maneuver. The sonar investigation indicates the difficulty in designing a sonar that can fulfill all design objectives year-round in a complex acoustic environment.*

ACCESSION NUMBER: ADA222805

**Watson, R.B. et al. User Guide and Specification for Discrete-Event Minehunting Simulation Model MHUNT.** Defence Science and Technology Organisation, Canberra (Australia): Mar 93. 75p.

*ABSTRACT: Minehunting is a complex process involving detection and classification of contacts using sonar and the subsequent identification and disposal of mines generally using a remotely operated underwater vehicle (ROV). However, making suitable assumptions, minehunting can be approximated by a series of connected events and thus made amenable to modelling using the technique of discrete-event simulation. In this report, a discrete-event minehunting simulation model is described together with instructions for its operation. The model can be applied to evaluate the effectiveness of minehunting systems for a given operational scenario and also to investigate new concepts.*

ACCESSION NUMBER: ADA304116

**Wave Walker.** Phase I . Final rept. Redzone Robotics, Inc., Pittsburgh, PA: 30 Nov 94. 34p.

*ABSTRACT: Improved near shore mine detection and neutralization capability is needed by the U.S. Navy. Analysis of the littoral warfare mission and the Persian Gulf experience identified this need. The littoral warfare mission increases emphasis on near shore and amphibious operations. Mine detection and neutralization involves a number of tasks and many efforts are underway to improve existing capabilities. The Office of Naval Research is using the SBIR program as part of these capability improvement activities. Red Zone Robotics received a Phase I SBIR contract to develop a concept for a walking robot that can operate in near shore environments. This robot would be used to clear near shore areas of mines before an assault. In operation, many robots would be released near the mine field with a general heading for the area to be cleared. The robots would proceed to spread out and canvas the area for mines. When a robot encountered a mine, it would stop and enter a wait mode. If other robots discovered the same mine, they would sense that a robot was already there in wait mode. When the area had been adequately covered, explosive charges in the robots would be detonated to destroy the mines and the robots.*

ACCESSION NUMBER: ADA288332

Widmayer, R.S. **Strategic and Industrial Assessment of Sea Mine Warfare in the Post-Cold War Era. --Research rept.** Aug 92-Apr 93. Industrial Coll. of the Armed Forces, Washington, DC: Apr 93. 33p.

*ABSTRACT: The purpose of my paper is to provide a strategic-level assessment of sea mine warfare in the post-Cold War era by addressing both government and industrial points of view. I review and summarize U.S. national security and military strategies vis-a-vis mine warfare, and I emphasize the basic roles mine warfare has the potential of playing in implementation of these strategies. The strategic role of mine countermeasures in future regional crises and contingencies is clear cut, having been unquestionably demonstrated during Desert Storm. However, the role of in is far less defined, but, as I substantiate in my paper, is also of significant strategic importance in the future. I recommend maintaining and preferably expanding the mine countermeasures program being supported by the Navy, and I recommend initiating a program to tune our mine inventory to the post-Cold War era threat. From the industrial perspective, I offer the significantly expanding mine countermeasures program as a very attractive industrial incentive. In addition, I provide several recommendations for both industry and government to help enhance the role industry can play in mine warfare in the future.*

ACCESSION NUMBER: ADA276881

Williams, K.E. et al. **Proceedings of the Ship Control Systems Symposium (5th), Held at U. S. Naval Academy, Annapolis, Maryland on October 30 - November 3, 1978.** Volume 5. David W. Taylor Naval Ship Research and Development Center, Annapolis, MD: 3 Nov 78. 241p. [See also Volume 6, AD-A159 086.]

*ABSTRACT: Partial contents: A New Look at Some Old Ship Handling Problems Employing CAORF's Man-in-the-Loop Ship Simulator; Red or White Light on Ship Bridges; Ships Pilotage in Britain - Past, present, and future; Criteria Optimized by Collision Avoidance Strategies; FFG-7 Class Propulsion Controls - Design and dynamic performance; Simulation and Performance Evaluation of a Mine Countermeasures Vessel Concept; Propulsion Control Optimization of Controllable Reversible Pitch Propeller Driven Ships; A Microprocessor-Based Stabilizer Fin Control System; Use of Micro Processors in Surface Ships Bridge Control Systems; Microprocessor Software - A structured approach to control & surveillance software for marine applications; and Propulsion Control System for the 1980's.*

ACCESSION NUMBER: ADA159085

**Wire Sweep Monitoring Equipment (WSME) Test Report. Test and evaluation rept.**

Performer: Naval Coastal Systems Center, Panama City, FL.: Dec 88. 58p.

*ABSTRACT: Naval Sea System Command tasked Naval Coastal Systems Center to evaluate the Wire Sweep Monitoring Equipment (WSME) which is currently in production by BAJ LTD for use on the UK Royal Navy River Class Fleet Minesweepers. The US Navy is building two new classes of mine countermeasure ships (MCM-1 and MHC-51) and the usefulness of WSME is being evaluated for applicability to these new ships. The WSME system offers the potential for improvement in performance to both in-service and developmental mechanical minesweeping equipment. The objective of this test were to evaluate the concept of sweeping by tension using WSME: Verify, using Size 1 equipment towed from an MSO class ship, that a flat mechanical minesweeping profile could be achieved and maintained by towing at a constant tension, and compare sweeping by tension to the conventional sweeping by ship speed and define in terms of hog/sag the advantage and disadvantages of each method.*

ACCESSION NUMBER: ADA208751

Won, I.J. and K. Smits. **Airborne Electromagnetic Bathymetry**. Final rept. Naval Ocean Research and Development Activity, NSTL Station, MS.: Apr 85. 23p.

*ABSTRACT: An experimental airborne electromagnetic (AEM) survey was carried out in the Cape Cod Bay area to investigate the potential of extracting bathymetric information for a shallow ocean. A commercially available Dighem III AEM system was used for the survey without any significant modification. The helicopter-borne system operated at 385 Hz and 7200 Hz, both in a horizontal coplanar configuration. A concurrent ground truth survey included extensive acoustic soundings, as well as spot water conductivity measurements. Because of a lack of knowledge about the absolute system calibration figures, an acoustic-sounding calibration was made for each flight line using a small portion of AEM data to derive the zero-level signal, amplitude, and phase calibration factors for each coil pair. The interpreted bathymetric profiles show excellent agreement with corresponding acoustic depth profiles up to one (possibly more) skin depth of the source frequency. It is envisioned that with further improvements in hardware and software, the bathymetric resolution may extend beyond the skin depth. AEM data can also produce (as by-products) conductivity profiles of both seawater and bottom sediments that may find potential applications in mine warfare and offshore geotechnical engineering works.*

ACCESSION NUMBER: ADA158640

Woodward, R.L. and J.S. Mathias. **Ship Survivability Enhancement Program: Feasibility Study Report**. General document. Materials Research Labs., Ascot Vale (Australia). : Apr 92. 50p.

*ABSTRACT: This report examines the feasibility of undertaking a series of experiments and exercises, using a decommissioned Destroyer Escort, aimed at generating information that will enhance ship survivability. Consideration is given to the sites for these experiments, timing, cost and manpower implications to Navy and DSTO, and to the range of experiments to be undertaken. It is recommended that some experiments be undertaken immediately before decommissioning and some immediately after, and that the sites at which these are to be done should be in Western Australia. The recommended experiments fall into four groups (1) Electromagnetic Transient Propagation, (2) Underwater Explosive Shock Response, (3) Weapons Effects, Fire, Smoke, Damage Control and Personnel Protection, and (4) Weapons Demonstration Firings. A program is proposed whereby each set of experiments can be accepted or rejected as a whole without influencing the others.*

ACCESSION NUMBER: ADA250320

Yoerger, E.J. et al. **Surface Forward-Scattered Acoustic Measurements and Analysis**. Final rept. Naval Research Lab. Detachment, Stennis Space Center, MS: Jun 93. 5p.

*ABSTRACT: A shallow water, high-frequency acoustic experiment was conducted off the coast of Panama City Florida during August 1991. Acoustic measurements of surface forward scattering, surface reverberation, and direct path intensities were made utilizing two (2) large stationary towers resting on the seafloor. Each tower was equipped with horizontal and vertical receiving arrays, while the two (2) sources were located on only one of the towers. The water bottom was 30 m deep and covered with a fine, rippled sand. The range of acoustic frequencies varied from 20 kHz to 180 kHz. Concurrent environmental measurements including wave heights, sound velocity profiles, and sample cores were made. This paper reports on the surface forward-scattered measurements made at 24 kHz.*

ACCESSION NUMBER: ADA276998

Zatt, D.K. **Joint Operations in the James River Basin, 1862 - 1865.** Master's thesis 3 Aug 92-4 Jun 93. Army Command and General Staff Coll., Fort Leavenworth, KS: 4 Jun 93. 128p.

*ABSTRACT: This study is an analysis of Union joint operations in the James River Basin from 1862 to 1865. Specifically the contributions made by the Union Navy during the battles of this period. It begins with an analysis of the Peninsula Campaign conducted by Major General McClellan and Rear Admiral Louis M. Goldsborough in 1862 and concludes with the Union forces entry into Richmond in April 1865. The Union Navy played a significant role in shaping the outcome of battles for control of the James River and the eventual capture of Richmond. The Navy's control of the river allowed Grant to maintain his main supply base well forward in the theater. This enabled Grant to rapidly maneuver and resupply his force. The study provides lessons on the difficulties of joint operations and the requirements to ensure success in the joint arena. Furthermore, it provides today's U.S. military with a view of riverine and mine warfare operations and the implication of allowing these warfare areas to decay.*

ACCESSION NUMBER: ADA274011

## INTERNET SITES

### Advanced Concept Technology Demonstration Home Page

**URL:** [http://www.acq.osd.mil/at/actd\\_home.html](http://www.acq.osd.mil/at/actd_home.html)

From the Dept. of Defense's Acquisitions office, this provides links to several mine related programs.

**Countermine** <http://www.acq.osd.mil/at/CM/cm.html>

**Joint Countermine (CM)** [http://www.acq.osd.mil/at/CM/cm\\_more.html](http://www.acq.osd.mil/at/CM/cm_more.html)

### DOT&E Activity Summary and Program Oversight

**URL:** <http://www.dte.osd.mil/reports/FY95/toc95.html>

The Dept. of Defense's Office of the Director, Operational Test & Evaluation provides program information for several of the Navy's mine warfare programs (e.g. Coastal Minehunter [MHC], Mine Countermeasures [MCM] ship and the MH-53E Airborne Mine Countermeasures [AMCM] Helicopter).

### Mine Countermeasures Diving Systems

**URL:** <http://www.dciem.dnd.ca/DCIEM/EDU/G-02.html>

From Canada's Defence and Civil Institute of Environmental Medicine, this provides information about their efforts to improve and develop systems to enhance the operational efficiency and safety of mine-countermeasures (MCM) diving.

## **MINWARA -- Mine Warfare Association**

**URL:** *<http://www.minwara.org/>*

This is a non-profit organization devoted to education and the raising of awareness concerning mines. This site includes the Mine Lines newsletter, announcements and links to other related web sites.

## **NATO SACLANT Undersea Research Centre Home Page**

**URL:** *<http://www.saclantc.nato.int/>*

The Centre's mission is to conduct undersea research to assist SACLANT (NATO Supreme Allied Commander, Atlantic) and other MNCs in their mission to meet the challenge of the prevention of submarine attacks and the hostile use of sea mines.

## **Naval Postgraduate School's Center for Autonomous Underwater Vehicle Research**

**URL:** *<http://www.cs.nps.navy.mil/research/auv/auv.html>*

This site provides links to Underwater Robotics Laboratories on the Web, briefing notes, information about the Phoenix AUV, related thesis work, abstracts of publications and some papers in hypertext.

## **Navy Fact File: Mine Countermeasures Ships**

**URL:** *<http://www.navy.mil/navpalib/factfile/ships/>*

The Navy Dept.'s Fact File provides information and descriptions of the ship classes related to mine warfare (Mine Countermeasures Ships - MCM and Coastal Minehunter Ships - MHC).

## **NSWC Coastal Systems Station**

**URL:** *<http://www.ncsc.navy.mil/>*

The Naval Surface Warfare Center's Coastal Systems Station is a Navy research and development laboratory which specifically does research in the areas of sea and land mine countermeasures. Project areas include Joint Countermine Operations Simulation and Naval Mine Warfare Simulation.

## **The Unofficial Mine Warfare Home Page**

**URL:** *<http://www.ae.utexas.edu/~industry/mine/>*

Topics include underwater offensive and defense mining, mine countermeasures and explosive ordnance disposal. Also has various mine images as well as providing links to other related web sites.

# Appendix A-2

## LAND MINES AND DEMINING, 1970-1996: A BIBLIOGRAPHY



October 1996

Michaele Lee Huygen  
&  
Greta E. Marlatt

Dudley Knox Library  
Naval Postgraduate School  
Monterey, CA





**Please note: not all these resources are available in the Dudley Knox Library but they can be requested through Interlibrary Loan.**

## **BOOKS**

- Bigl, Susan R. **Change in orientation of artillery-delivered anti-tank mines in snow.** [Hanover, N.H.]: US Army Corps of Engineers, Cold Regions Research & Engineering Laboratory, [1984]. CRREL report ; 84-20. 20 p.
- Bingham, Price T. **Air power and the defeat of a Warsaw Pact offensive: Taking a different approach to air interdiction in NATO.** Maxwell Air Force Base, Alabama: Air University Press, 1987. AU-ARI-CP ; 87-2. 41 p.
- Bottoms, Albert, James N. Eagle, and Howard Bayless (eds.). **Proceedings of the Autonomous Vehicles in Mine Countermeasures symposium, 1995.** Monterey, CA: Naval Postgraduate School, 1995.
- Cahill, Kevin M. (ed) **Clearing the fields: solutions to the global land mines crisis.** New York : Basic Books, 1995. 237 p.
- Cahill, Kevin M and Thomas Roma. **Silent witnesses.** [New York?]: United Nations: Center for International Health and Cooperation: Worldwide distribution by HarperCollins, c1995. 91 p.
- Chan, Philemon C. et al. **Acceleration threat to truck occupants due to land mine explosions.** IN: SAFE Association (U.S.). Symposium. Proceedings of the annual symposium, SAFE Association. 33rd (1995). p. 447-460.
- Convention on Prohibitions or Restrictions on the Use of Certain Conventional Weapons (1980) **Convention on Prohibitions or Restrictions on the Use of Certain Conventional Weapons: message from the President of the United States transmitting the Convention on Prohibitions or Restrictions on the Use.** [Corr. print.]. Washington, D.C. : U.S. G.P.O., 1995. Treaty doc. ; 103-25. 23 p.
- Cornish, Paul. **Anti-personnel mines: controlling the plague of 'butterflies'.** London : Royal Institute of International Affairs, c1994. 38 p.
- Davies, Paul. **War of the mines: Cambodia, landmines and the impoverishment of a nation.** London [England]; Boulder, CO., U.S.A.: Pluto Press, 1994. 172 p.

- De Waal, Alexander. **Violent deeds live on: landmines in Somalia and Somaliland.** Cockermouth, Cumbria [England]: Mines Advisory Group; London African Rights, [1993]. 82p.
- Disarmament Week Symposium (1994: United Nations) **Disarmament : ending reliance on nuclear and conventional arms.** New York: United Nations, c1995. 155 p.
- Dubey, Abinash C. et al (eds.) **Detection and remediation technologies for mines and minelike targets.** 9-12 April 1996, Orlando, Florida; sponsored by SPIE--the International Society for... Bellingham, Wash.: SPIE, c1996. Proceedings of SPIE--the International Society for Optical Engineering; v. 2765. 588 p.
- Dubey, Abinash C. et al (eds.) **Detection technologies for mines and minelike targets.** 17-21 April 1995, Orlando, Florida; sponsored and published by SPIE--the International Society for... Bellingham, Wash., USA: SPIE, c1995. Proceedings of SPIE--the International Society for Optical Engineering; v. 2496. 1036 p.
- Fine, Jonathan E. **Hidden enemies: land mines in Northern Somalia: a report.** Boston, MA: Physicians for Human Rights, 1992. 51 p.
- Geyer, Richard G. **Magnetostatic measurements for mine detection.** Boulder, CO. : National Institute of Standards and Technology, U.S. Dept. of Commerce, 1988. NISTIR ; 88-3098.
- Handbook of employment concepts for mine warfare systems.** Fort Belvoir, VA.: U.S. Army Engineer Center and School, [1986]. 155 p.
- Harber, David. **Improvised land mines: their employment and destructive capabilities.** Boulder, CO: Paladin Press, 1992. 80 p.
- Hidden death : landmines and civilian casualties in Iraqi Kurdistan.** Middle East Watch. New York: Human Rights Watch, [1992]. 67 p.
- Jane's military vehicles and logistics.** Coulsdon, Surry, U.K.; Alexandria, VA: Jane's Information Group, 1991- [annual]
- Janes Mines and Mine Clearance.** Colin King, Editor. Janes Information Group Ltd., Surrey, UK. Nov 1996. Hardback print and CD-ROM formats. (Call 1-800-243-3852).
- Land mines in Cambodia: the coward's war, September 1991.** Asia Watch, Physicians for Human Rights. [New York]: Asia Watch: Human Rights Watch, 1991. 129 p.
- Land mines in El Salvador and Nicaragua: the civilian victims.** New York, NY: Americas Watch Committee, c1986. 117 p.

- Landmines: a deadly legacy.** The Arms Project of Human Rights Watch & Physicians for Human Rights. New York: Human Rights Watch, c1993. 510 p.
- Landmines and Demining: A Global Problem.** [CD-ROM] Charlottesville, VA: National Ground Intelligence Center, 1996?
- Landmines in Mozambique.** Human Rights Watch Arms Project [and] Human Rights Watch/Africa (formerly Africa Watch). New York: Human Rights Watch, c1994. 119 p.
- McGrath, Rae. **Land mines in Angola: An Africa Watch Report.** New York: Human Rights Watch, c1993. 69 p.
- Mine warfare.** Peking, Foreign Languages Press, 1971. 6 p. [178 p. of illustrations]
- Morris, Michael et al. **Limpet-mine sabotage in South Africa : weapon data, saboteur tactics, incident list.** Cape Town, S.A.: Terrorism Research Centre, c1982. 54 p.
- Omaar, Rakiya et al. **Violent deeds live on: land mines in Somalia and Somaliland.** London: African Rights and Mines Advisory Group, [1993] 82 p.
- Pena Gomez, Manuel Vicente. **Un pueblo mutilado: El Carmen de Chucuri.** [Bogota, Colombia]: Fundacion para los Deberes Humanos, [1994?]. 75 p.
- Prokosch, Eric. **The technology of killing: a military and political history of antipersonnel weapons.** London; Atlantic Highlands, NJ: Zed Books, c1995. 224 p. ; 23 cm.
- Reports of El Salvador: mines.** [San Salvador]: Ministry of Foreign Affairs, El Salvador, 1988. 40 p.
- Roberts, Shawn. and Jody Williams. **After the guns fall silent: the enduring legacy of landmines.** 1st. ed. Washington, D.C.: Vietnam Veterans of America Foundation, 1995. 554 p.
- Sloan, C. E. E. **Mine warfare on land.** London; Washington, D.C.: Brassey's Defence Publishers, 1986. 153 p.
- Smith, Christopher. "Anti-Personnel Mines: The Arguments Over Military Utility." pgs. 273-285 chap in **Brassey's Defence Yearbook.** London: Brassey's, Center for Defence Studies, 1996.
- Stiff, Peter. **Taming the landmine.** Alberton, RSA: Galago, 1986. 128 p.

Stolfi, Russel, H.S. **Mine and countermine warfare in recent history, 1914-1970.** BRL Report no. 1582. Aberdeen Proving Ground, MD: Ballistic Research Laboratories, 1972. 166 p.

Towle, Philip. **Limiting the use of conventional weapons: prospects for the 1979 UN conference: the future of incendiaries, cluster bombs, high velocity rifles, fuel-air explosives and land mines.** Canberra: Research School of Pacific Studies, Australian National University, [1979] 22 p. [Working paper / Strategic and Defence Studies Centre; no. 9]

United States. Congress. Senate. Committee on Appropriations. Subcommittee on Foreign Operations, Export Financing, and Related Programs. **The global landmine crisis:** hearing before a subcommittee of the Committee on Appropriations, United States Senate, One Hundred Third Congress, second session, special hearing. Washington, D.C. : U.S. G.P.O. : , 1994. 137 p.

United States. Congress. Senate. Committee on Foreign Relations. **Convention on Prohibitions or Restrictions on the Use of Certain Conventional Weapons: report (to accompany Treaty doc. 103-25)** [Washington, D.C.? : U.S. G.P.O., 1995]. Senate Executive report; 104-1. 31 p.

United States. Department of State. **The global landmine crisis: 1994 report to the U.S. Congress on the problem with uncleared landmines and the United States strategy for demining and landmine control.** [Washington, D.C.] : United States. Department of State, Bureau of Political-Military Affairs, Office of International Security Operations. [1994]. [27] p. ["Hidden killers 1994 : the global landmine crisis."]

\_\_\_\_\_. **Hidden killers: the global problem with uncleared landmines: a report on international demining.** [Washington, D.C.]: United States. Department of State, Political-Military Affairs Bureau, Office of International Security Operations., [1993]. 185 p.

United States. Dept. of the Army. **Boobytraps.** Washington D.C. :Dept. of the Army, 1965. Field manual, 5-31. 132 p.

\_\_\_\_\_. **Land mine warfare.** Washington, D.C.: Department of the Army, 1949. Field manual ; 5-31. 218 p.

\_\_\_\_\_. **Mine/countermine operations.** [Washington, DC] : Headquarters, Dept. of the Army, 1986- Field manual; FM 20-32.

United States. General Accounting Office. **Cambodia: limited progress on free elections, human rights, and mine clearing** . Washington, D.C.: The Office , 1996. GAO/NSIAD-96-158BR.

\_\_\_\_\_. **Mine warfare: consolidation at Ingleside has not been justified** . Washington, D.C.: The Office, 1993. GAO/NSIAD-93-147. 10 p.

\_\_\_\_\_. **Mine warfare: Ingleside, Texas, may not be the best location for consolidation** . Washington, D.C.: The Office, 1991. GAO/NSIAD-92-63. 7p.

\_\_\_\_\_. **Mission area analyses conducted by the Army Training and Doctrine Command.** Washington, D.C.: The Office, 1983. GAO/MASAD-83-20. 4p.

\_\_\_\_\_. **Unexploded Ordnance: a coordinated approach to detection and clearance is needed.** Washington, D.C.: The Office, 1983. GAO/NSIAD-95-197. 30p.

United States. Joint Chiefs of Staff. **Joint doctrine for barriers, obstacles, and mine warfare.** Washington, D.C.: Joint Chiefs of Staff, 1993- Joint pub ; 3-15.

United States. War Department. **Land mines and booby traps** : War Department [Corps of Engineers], 1 November 1943. Washington, D.C.: United States Gov't Printing Off., 1943. War Department field manual; FM 5-31.

**Victimas civiles del uso de minas sembradas en tierra en El Salvador y Nicaragua.** New York, NY: Americas Watch Committee, 1987. 97 p.

Voldman, Daniele. **Attention mines -- 1944-1947.** Paris: Editions France-Empire, c1985. 190 p.

Walker, John K., Jr. **Air scatterable land mines as an Air Force munition** . Santa Monica, CA: Rand Corporation, 1978. 19 p.

## **PERIODICALS**

Aakre, Keith E. "Volcano -- Providing Army Aviation With a UH-60 Scatterable Mining Capability." **USA Aviation Digest** Nov 1986 v. 32. p. 40-45.

"After the Storm: Special Report." **Jane's Defence Weekly** Apr 6, 1991 v. 15, no. 14. p. 529-532+

"AJAX/APILAS Off-Route Mine Demonstrates Its Punch." **Asian Defence Journal** Nov 1987 no. 11. p. 68-69.

- Akins, Frank T. "Mine-Clearing Line Charge (MICLIC): Avoiding an Engineer's Nightmare." **Engineer** Dec 1994 v. 24. p. 18-24.
- Alder, Konrad. "Modern Land Mine Warfare." **Armada International** Nov-Dec 1980 v. 4. p. 6-8+
- Alexander, David R. "Antihelicopter Mines: The Emerging Threat to Helicopter Operations." **U.S. Army Aviation Digest** May-Jun 1993 no. 3. p. 37-43.
- Andersson, Neil et al. "Social Cost of Land Mines In Four Countries: Afghanistan, Bosnia, Cambodia, and Mozambique." **British Medical Journal** Sept 16, 1995 v. 311, no. 7007. p. 718+
- Andrews, Michael A. "Tank-Delivered Scatterable Mines." **Military Review**. Dec 1978 v. 58. p. 34-39.
- "AN/PSS-12 Handheld Metallic Mine Detector." **Army** Mar 1991 v. 42, no. 3. p. 54-55.
- "AN-19/2 -- The 'Finale' Mine Detector." **Asian Defence Journal** Sept 1994 no. 9. p. 68-69.
- "Anti-Tank Mines and Countermeasures." **Asian Defence Journal** Apr 1983 no. 4. p. 26+
- "Area Defence By Mine Deployment." **Asian Defence Journal** Feb 1983 no. 2. p. 64-65.
- Armbruster, Francis E., Jr. "Tandem Vehicle Clears Minefields." **Military Engineer** Nov-Dec 1989 v. 81 p. 68-71.
- Armstrong, Charles L. "Mines & Boobytraps -- A Primer." **Marine Corps Gazette** June 1990 v. 74, vo. 6. p. 23-24.
- "Army Completing Field, Flight Tests of Volcano Mine Dispensing System." **Aviation Week & Space Technology** February 15, 1988 v. 128 p. 93.
- "Army's Armor Acquisition Hub Adapts to New Market." **National Defense** Jan 1995 v. 79, no. 504. p. 32-33.
- Ary, Vaughn A. "Concluding Hostilities: Humanitarian Provision in Cease-Fire Agreements." **Military Law Review** Spring 1995 v. 148. p. 186+
- Ashley, Steven. "Flushing Out Land Mines." **Mechanical Engineering** Mar 1992 v.114 p.122.

- \_\_\_\_\_. "Searching for Land Mines; Sophisticated Mine Detectors." **Mechanical Engineering-CIME** Apr 1996 v.118, no. 4. p. 62+
- Askin, Steven and Stephen Goose. "The Market For Anti-Personnel Landmines -- A Global Survey." **Jane's Intelligence Review** Sept 1994 v. 6, no. 9. p. 425-431.
- Backofen, Joseph, Jr. and Larry W. Williams. "Antitank Mines." **Armor** pt 1., Jul-Aug 1981 v. 90 p. 26-30; pt.2. Sept-Oct 1981, v. 90. p. 35-37; pt. 3. Nov-Dec 1981 v. 90. p. 34-39.
- Bailey, Tom. "Only a Step Away." **Army Digest** Mar 1971 v. 26. p. 64-65
- Baker, Brian L. "Standoff Minefield Detection System." **Engineer** Mar 1989 v.18. p. 11.
- Baxter, William P. "Soviet Mine Warfare: Army's 'Silent Death'." **Army** Jul 1982 v. 32. p. 42-44.
- Belov, M. "Remote Mining." **Soviet Military Review** June 1977 no. 6. p. 26-27.
- Bennett, Drew A. "Minefield Breaching: Doing the Job Right." **Armor** July-Aug 1992 v.101, no. 4. p.19-21.
- Bennett, Stephen H. "Multipurpose Mine Probe." **Marine Corps Gazette** Sept 1989 v.73. p. 43.
- Berg, Robert. "Evaluating Robotics Systems." **Engineer** Aug 1994 v. 24. p. 10-13.
- Berhow, James. E. "Operating a Mine Detector: Proficiency Through Practice." **Engineer** Aug 1994 v. 24. p. 22-24.
- Berk, Walter L. "Mine Clearance Abetted by Enhanced Technology." **National Defense** Oct 1994 v. 79, no. 501. p. 32-33.
- Blass, Eric H. "Demining: The Finnish Line." **Armada International** Dec-Jan 1994-1995 v. 18, no. 6. p. 30-31.
- Birch, Stuart. "How They Build the Spider Mine." **The Engineer** (London, England) Nov 21, 1985 v. 261. p. 36.
- Blagden, P.M. "Kuwait: Mine Clearing After Iraqi Invasion." **Army Quarterly & Defence Journal** Pt. 1. Jan 1996 v. 126, no. 1. p. 4-12.
- Boatman, John. "Sweep Up After the Storm (US Involvement in Mine and Munitions Clearance in Kuwait)." **Jane's Defence Weekly** May 9, 1992 v.17, no. 19. p. 821-822.



- Bonsignore, Ezio. "Land Mines -- No More?" **Military Technology** Apr 1994 v. 18, no. 4  
p. 68-69+
- Boschmann, Peter. "Mobile Barrier -- Land Mine Warfare in the 90s." **NATO's Sixteen Nations**  
Jul 1986. v. 31. p. 54-56+
- "Bosnia: After the Troops Leave." **The Washington Quarterly** Summer 1996 v. 19, no. 3.  
p. 59+
- Boutro-Ghali, Boutros. "The Land Mine Crisis: A Humanitarian Disaster." **Foreign Affairs**  
Sept-Oct 1994 p. 8+
- Buchanan, Nancy. "Bofors Demining Vehicle Demonstration." **Armada International**  
Feb-Mar 1996 v. 20, no. 1 p. 56-57.
- \_\_\_\_\_. "Mine Warfare From A Different Perspective." **Armada International** Feb-Mar 1995  
v. 19, no. 1. p. 20+
- Bunten, Kathleen. "Mines in Bosnia: A Lethal Legacy." **Jane's Defence Weekly** May 29, 1996  
v. 25, no. 22. p. 16-17.
- Caires, Greg. "Army Looks to South Africa for Bosnia Countermining Effort." **Defense Daily**  
May 29, 1996 v. 191, no. 42.
- "Cambodia: Recent Developments." **US Department of State Dispatch** May 23, 1994  
v. 5, no. 21. p. 343-344.
- Campbell, James L. and John Moser. "The Commander Has Less Mobility Than He Thinks."  
**Infantry** Mar-Apr 1973 v. 63. p. 52-54.
- Carnahan, Burris M. "The Law of Land Mine Warfare: Protocol II to the United Nations  
Convention on Certain Conventional Weapons." **Military Law Review** Summer 1984,  
no. 105. p. 73-95.
- Castella, Paul. "Operation Salam--Mine Clearance for the Mujahideen." **International Defense**  
**Review** Feb 1990 v. 23, no. 2. p. 141-142.
- Chignell, R. J.; et al. "Early Development in Ground-Probing Radar at ERA Technology Ltd."  
**IEE Proceedings. Part F, Communications, Radar and Signal Processing** August  
1988 v.135 p.362-70.
- Chirio, Lawrence M. "Lessons Learned: Kuwaiti Demining Operations." **Engineer** Aug 1994  
v. 24. p. 25-28.

- Christopher, Warren M. "Hidden Killers: U.S. Policy on Anti-Personnel Landmines: Remarks Upon Release, State Dept Report Hidden Killers: The Global Landmine Crisis 1994." **DISAM Journal** Summer 1995 v. 17, no. 4. p. 81-84.
- Coisplet, Michel. "Stopping the Tank -- A European Project: MACPED/ACEATM." **NATO's Sixteen Nations** Dec 1990 v. 35, no. 7. p. 36-37+; **Military Technology** Apr 1991 v. 15, no. 4. p.71+
- "Combat Engineering: Minefield Breaching -- Soviet Style." **Defense Update International** 1985 no. 63. p. 37-41.
- Connor, Steve. "Ground Wars." **New Scientist** July 23, 1987 v.115 p.44-9.
- Cooper, Pat. "Combatants Embrace Mines Despite Ban Efforts." **Defense News** July 8, 1996 p.10+
- \_\_\_\_\_. "Countermine Technologies Flow From Increased Threat." **Defense News** July 8, 1996 p. 10+
- Coupland, Robin M. and Adriaan Korver. "Injuries From Antipersonnel Mines: The Experience of the International Committee of the Red Cross." **British Medical Journal** Dec 14, 1991 v. 303, no. 6816. p. 1509+
- Crevecoeur, Pierre. "Anti-Tank Defence." **Armada International**. May-June 1982. v.6. p. 57+
- \_\_\_\_\_. "Anti-Tank Mines of the Second Generation." **Armada International** Jan-Feb 1984 v. 8. p. 26+
- \_\_\_\_\_. "Second-Generation AT Ground Mines." **Armada International** Jul 1985 v. 9. p. 45-46+
- \_\_\_\_\_. "The FFV 028 Anti-Tank Mine." **International Defense Review** June 1977 v. 10. p. 529-530.
- Curtis, Ian G.S. "Today's Battlefield Mobility Gives New Importance to Battlefield Engineering." **Defense and Foreign Affairs Strategic Policy** Dec 1990 v. 18, no. 12. p. 22-24.
- "Danish Conference Heightens Landmine Awareness." **Defense Week** July 22, 1996 v. 17, no. 30.
- Deen, Thalif. "UN Peacekeepers Latest Victims in Landmine War." **Jane's Defence Weekly** Jan 24, 1996 v. 25, no. 4. p. 5.

- delle Capre, Enrico. "Barrage Rockets." **Asian Defence Journal** July-Aug 1980 No. 4.  
p. 61-62+
- "Demining Honduras." **Soldiers** May 1 1996 v. 51, no. 5. p. 21.
- Dickey, Alan. "Anger as Mine-Hunter Order Goes to US-France Consortium." **The Engineer**  
(London, England) July 10, 1986 v. 263. p. 6.
- Dodd, Norman L. "Mines and Mine Clearance." **Asian Defence Journal** Dec 1983. no. 12.  
p. 74-76+.
- \_\_\_\_\_. "New Off-Route Mine Will Destroy Any Tank." **Pacific Defense Reporter** Feb 1988  
v. 14. p. 42.
- Dodds, Henry. "MTK Mine Clearing Systems." **Jane's Intelligence Review** Oct 1991 v. 3,  
no. 10. p. 478-480.
- Donnelly, John. "GAO, Army Differ On Effectiveness Of Top Mine Detector." **Defense Week**  
September 16, 1996. v. 17, no. 37.
- Dorris, Albert F. "Engineer Support for the Combined Arms Team." **Armor** Sept-Oct 1980  
v. 89 p. 39-43.
- Draper, Stephen E. "Mobility/Counter-mobility in Winter Warfare." **Defense Update**  
**International** 1984 no. 45. p. 55-63.
- Dunham, Steven R. and Richard G. Rhett. "REMIDS (Remote Minefield Detection System)." **Engineer** Mar 1989 v. 18. p. 12-13.
- Duval-Destin, Marc and Michel Thomas. "Mine Clearance: A Key Factor in Resolving Future  
Crises." **Military Technology** Sept 1994 v. 18, no. 9 p. 62-65.
- Eberharter, Steven. "Mine Awareness." **Engineer** May 1996 v. 26. p. 11-15.
- Eshel, Tamir. "End to Static Deterences? Mine Warfare in the 1980s and Beyond." **Defense**  
**Update International** Nov 1988 no. 91. p. 42-49.
- Eubanks, Catherine. "Schiebel AN19/2 Hand-Held Mine Detector: A Canadian's View; includes  
an interview with LtCol Normand Levert." **Engineer** Aug 1994 v. 24. p. 29-31.
- Evers, Stacy. "Plough (De-Mining Device) May Face Bosnia Test." **Jane's Defence Weekly**  
Jan 31, 1996 v. 25, no. 5. p. 82.

- "Explosion in the Market (For Mines)?" **International Defense Review** 1986 v. 19, no. 3.  
p. 294-299.
- "Fact Sheet: U.S. Initiative for Demining And Landmine Control." **US Department of State Dispatch**. May 30, 1994 v. 5 no. 22. p. 362.
- "Fact Sheet: U.S. Initiatives for Demining and Landmine Control." **US Department of State Dispatch** Feb 6, 1995 v. 6, no. 6. p. 72.
- "Fact Sheet: U.S. Policy on a Landmine Control Regime." **US Department of State Dispatch** Sept 26, 1994 v. 5, no. 39. p. 637.
- "Fact Sheet: U.S. Proposals To Improve the Landmines Protocol of the Convention on Conventional Weapons." **US Department of State Dispatch** Sept 25, 1995 v. 6, no. 39. p. 710.
- Flamm, Don. "Critical Need for Army Non-Metallic Mine Detectors." **Asian Defence Journal** Nov 1990 no.11. p. 52+
- Flamm, Mikel. "'Hidden Shadows' -- Landmines and Misery in Cambodia." **Asian Defence Journal** Oct 1993 no. 10. p. 23+
- \_\_\_\_\_. "'Land Mines in Cambodia -- The most Heavily Mined Country in the World.'" **Asian Defence Journal** May 1993 no. 5. p. 27-28.
- Forbes, Gordon J. "Mine Warfare Capability for Canada." **Canadian Defense Quarterly** Apr 1989 v. 18 p. 34-36+
- Ford, Max B. "TEXS (Tactical Explosive System) Neutralizes Mines." **Military Engineer** Aug 1985 v. 77. p. 456-457.
- Foss, Christopher F. "Designing a Path To Safety (A New Mineclearing System Developed By Israel)." **Jane's Defence Weekly** Feb 5, 1994 v. 21, no. 5. p. 20.
- Fowler, Will. "Mine Warfare, Laying, Detecting and Neutralising." **Asian Defence Journal** Feb 1995. no. 2. p. 46+
- Friedman, Avner. "Detection of Mines By Electric Measurements." **SIAM Journal on Applied Mathematics** Feb 1987 v. 47. p. 201-12.
- Frost, Roger. "Italy's Mine Makers." **International Defense Review** 1986 v. 19, no. 5.  
p. 655-660.

- "Funds for Demining in Cambodia." **Insight** Mar 14, 1994 v. 3, no. 3. p. 10.
- Furlong, R.D. M. "WAAM (Wide Area Anti-Armour Munitions) -- the U.S. Air Force's Next Generation of Anti-Armour Weapons." **International Defense Review** 1978 v. 11, no. 9. p. 1378-1379.
- Fursdon, Edward. "Saving Afghans From Lethal Litter." **Pacific Defence Reporter** Mar 1990 v. 16, no. 9. p. 31-32+
- Galitsky, Y. "Mine Obstructions in Mountains and Deserts." **Soviet Military Review** Jan. 1971 no. 1. p. 24-26.
- Gander, Terry J. "Iraq's Bicycle Wheel Mine." **Jane's Intelligence Review** Aug 1991 v. 3, no. 8. p. 355.
- \_\_\_\_\_. "MON Mines." **Jane's Soviet Intelligence Review** Jan 1990 v. 2, no. 1. p. 44 . [pictorial only].
- \_\_\_\_\_. "MVN-72 Magnetic Fuze." **Jane's Soviet Intelligence Review** Nov 1989 v. 1. p. 501.
- \_\_\_\_\_. "MVZ-62 Anti-Tank Land Mine Fuze for TM-62 Mines." **Jane's Soviet Intelligence Review** June 1990 v. 2, no. 6. p. 258-259.
- \_\_\_\_\_. "OZM Bounding Anti-Personnel Mine Series." **Jane's Soviet Intelligence Review** May 1989 v. 1. p. 213.
- \_\_\_\_\_. "PGMDM Scatterable Anti-Tank Mine." **Jane's Soviet Intelligence Review** Apr 1989 v. 1. p. 153.
- \_\_\_\_\_. "POM-K Scatterable Anti-Personnel Mine." **Jane's Soviet Intelligence Review** Mar 1991 v. 3, no. 3. p. 128-130.
- \_\_\_\_\_. "Soviet Mine-Clearing Ploughs and Rollers." **Jane's Soviet Intelligence Review** Mar 1989 v. 1. p. 138-143.
- \_\_\_\_\_. "TM-83 Off-Route Mine." **Jane's Intelligence Review** Sept 1993 v. 5, no. 9. p. 389.
- Gander, Terry J. et al. "Disposing of the Threat." **International Defense Review** Oct 1995 v. 28, no. 10. p. 47-48+
- Geisenheyner, Stefan. "Landmines for Offence and Defence." **Asian Defence Journal** Apr 1983 no. 4. p. 12-15+

- \_\_\_\_\_. "Some Observations On Mine Warfare." **Asian Defence Journal** July-Aug 1980 no. 4.  
p.72-74+
- Glass, Jim. "STRAC (Standards in Training Commission): A Training Strategy That Works."  
**Engineer** Oct 1990 v. 20. p. 22-26.
- Goodman, Glenn, Jr. "From the Boardroom: Frank P. Ragano, President and Chief Executive  
Officer, CMS (Conventional Munitions Systems) Inc., Interview." **Armed Forces  
Journal International** Aug 1992 v. 130, no. 11. p. 56.
- Gordon, Martin K. "R&D in Wartime: The Tank Dozer." **Military Engineer** June-July 1994  
v. 86, no. 564. p. 88.
- Gourley, Scott R. "Countermine Programs for US Light Forces." **International Defense Review**  
Apr 1991 v. 24, no. 4. p. 323-324.
- Grant, Randall L. "Minerollers: Mobility For the Armor Task Force." **Armor** May-June 1986  
v. 95. p. 30-35.
- Grant, Richard B. "Mines Come of Age." **Marine Corps Gazette** Aug 1978 v. 62. p. 35-38.
- Graves, Ralph H. "AVLB (Armored Vehicle Launched Bridge) + MICLIC (Mine-Clearing Line  
Charge) = AVLM Or, How the AVLM Was Born." **Military Engineer** Mar-Apr 1992 v.  
84, no. 548. p. 9-12.
- Greville, P.J. "International Law Needed for Control of Mines." **Asia-Pacific Defence Reporter**  
Aug-Sept 1993 v. 20, no. 2-3. p. 40.
- Gribble, W.C., Jr. "Mine Warfare Problems." **Ordnance** Sept-Oct 1971 v. 56. p. 151.
- Guest, Tim. "'Dealing' with Minefields." **Military Technology** Aug 1987 v. 11. p. 82-85+
- \_\_\_\_\_. "European Programme With An Off-Route Solution." **Military Technology** July 1989  
v. 13, no. 7. p. 48+
- \_\_\_\_\_. "Intelligence Beneath the Surface: The HPD2 2nd-Generation, Anti-Tank Mine."  
**Military Technology** Apr 1989 v. 13. p. 110+
- Hackworth, David, H. "Automatic Ambush." **Infantry** May-June 1970 v. 60. p. 53-54.
- Hall, Keneth G. et al. "Standoff Minefield Detection Systems (STAMIDS) Advanced  
Technology Transition Demonstration (ATTD)." **Military Engineer** Aug 1991 v. 83, no.  
544. p. 16-17.

- Hallatshek, Josef R. "Infantry Breaching Kits." **Infantry** Sept-Oct 1992 v. 82, no. 5. p. 36-37.
- Hammick, Murray and Gerard Turbe. "Going Deep -- Countermining Ops Dig Beneath the Threat." **International Defense Review** Apr 1991 v. 24, no. 4. p. 316-317.
- Hammick, Murray et al. "Gulf War in Review." **International Defense Review** Pt. 1. May 1991 v. 24, no. 5. p. 451-453+; Pt. 2. July 1991 v. 24, no. 7. p. 735-738+; Pt.3. Sept 1991 v. 24, no. 9. p. 979-980+
- Hansen, John V.E. "Mine Games: Serious Business." **Military Engineer** June-July 1994 v. 86, no. 564. p. 32-34.
- Hanshaw, Terilee. "AMIDARS (Airborne Minefield Detection and Reconnaissance System). **Engineer** Mar 1989 v. 18. p. 14-15+
- Heck, Robert. "Mines on the Battlefield." **Armada International** Jan-Feb 1980 v. 4. p. 70-72+
- Heiberg, E.R. "Readiness... Preserves Peace." **Military Engineer** Jan-Feb 1988 v. 80. p. 14-19.
- Hesler, Stephen R. and Ronald N. Light. "Bullet Trap: Hastening the In-Stride Breach." **Engineer** Apr 1992 p. 47-49.
- Hewish, Mark. "Land Mines -- Cheap and Effective Area Denial." **International Defense Review** 1986 v. 19, no. 8. p. 1085-1091.
- \_\_\_\_\_. "Robots on the March." **International Defense Review** - Extra, August 1, 1996 v. 1, no. 8. p. 1+
- \_\_\_\_\_. "The British Army's New Mine Plough." **International Defense Review** 1984 v. 17, no. 5. p. 617-618.
- Hewish, Mark and Leland Ness. "Mine-Detection Technologies." **International Defense Review** Oct 1995 v. 28, no. 10. p. 40+
- "Hidden Killers: U.S. Policy On Anti-personnel Landmines." **US Department of State Dispatch** Feb 6, 1995 v. 6, no. 6. p.71.
- Hiemstra, Michael A. "CMTC (Combat Maneuver Training Center): Stability Operations Training." **Field Artillery** Mar-Apr 1996 p. 20-21.
- Hocke, Reinhold and Michael S. Humphreys. "Demining Germany's Borders." **Engineer** Aug 1994 v. 24, no. 3. p. 14-19.

- Howell, Milton L. Jr. "Scatterable Mines." **Military Engineer** Nov-Dec 1977 v. 69. p. 396-399.
- Ide, Douglas. "Demining Honduras." **Soldiers** May 1996 v. 51, no. 5. p. 21.
- "Israeli Mine Plough." **International Defense Review** 1985 v. 18, no. 5. p. 795.
- Jean, Barbara. "Clearing the Perilous Road To Peace." **International Defense Review - Extra** February 1, 1996 v. 1, no. 2. p.1+
- Jefferson, Paul. "Soviet Directional Anti-Personnel Mines." **Jane's Soviet Intelligence Review** Aug 1990 v. 2, no. 8. p. 346-350.
- Johnson, Richard H. "Lethal Legacy of Land Mines." **Army** Jan 1994 v. 44, no. 1. p. 34-39.
- Jones, Mel R. "Mine Warfare Preparedness Begins Recovery After Years of Neglect." **Defense Systems Review** Jul-Aug 1984 v. 2. p. 37-39.
- Karnoil, Robert. "Asia Resisting UN Efforts to Extend Landmine Treaty." **Jane's Defence Weekly** Jun 17, 1995 v. 23, no. 24. p. 25.
- \_\_\_\_\_. "Clearing a Path To Peace (Disposing of Millions of Mines Laid in Cambodia). **Jane's Defence Weekly** May 16, 1992 v. 17, no. 20. p. 856+
- Kearney, Jack. "Gator Mine." **USAF Fighter Weapons Review** Fall 1986 v. 34. p. 6-9.
- Kervin, Frank W. "The M-56 Scatterable Mine System." **USA Aviation Digest** April 1978 v. 24. p. 44-46.
- King, Colin. "Former Yugoslav Booby Traps." **Jane's Intelligence Review** Feb 1995 v. 7, no. 2. p. 57-60.
- \_\_\_\_\_. "Former Yugoslav Land Mines." **Jane's Intelligence Review** Jan 1995 v. 7, no. 1. p. 15-18.
- \_\_\_\_\_. "Land Mines in Cambodia." **Jane's Intelligence Review** Pt. 2. July 1995 v. 7, no. 7. p. 311-314; Pt. 1, June 1995 v. 7, no. 6. p. 273-276.
- \_\_\_\_\_. "The Mine Conundrum: The Threat to Mine-Clearance Operations." **Jane's Intelligence Review -- Special Report No. 8** 1995 Entire issue.
- Kitching, John. "Land Mine Warfare." **International Defense Review** Oct 1975 v. 8 p. 691-694.
- \_\_\_\_\_. "Minefield Breaching." **International Defense Review** June 1977 v. 10. p. 523-525.



- Kleiner, Kurt. "Robotic Insects Tread Where Humans Fear to Go." **New Scientist** February 24, 1996 v. 149. p. 14.
- Knyazkov, Viktor. "Mine Dectectors." **Soviet Military Review** Mar 1986 no. 3. p. 26-27.
- \_\_\_\_\_. "Mines." **Soviet Military Review** May 1987 no. 5. p. 21-22.
- Kolcum, Edward H. "GPS, Other New Technologies Help Clear Ordnance From Kuwaiti Desert." **Aviation Week & Space Technology** April 27, 1992 v. 136. p. 54-5.
- Kowadlo, Keith. "Visualizing Mine/Countermining Operations As Part of Synchronization." **Engineer** Feb 1994 v. 24. p. 18-20.
- "Kuwait -- Cleaning Up After The Storm." **Armada International** Jun-July 1992 v. 16, no. 3. p. 60+
- "Land Forces Update." **Jane's Defence Weekly** June 3, 1995 v. 23, no. 22. p. 33.
- "Land Mine Warfare: Detection and Clearance." **The DTIC Review** March 1996 v.2, no. 1. entire issue. <http://www.dtic.mil/dtic/review/review2.html#papers>.
- "Landmines: The Real Weapons of Mass Destruction." **The Defense Monitor** July 1996 v. 25, no. 5. entire issue.
- Lane, Larry. "Mapping Bosnian Minefields." **Soldiers** Apr 1996 v. 51, no. 4. p. 18-21.
- \_\_\_\_\_. "Step At A Time (Land Mine Warfare Class)." **Soldiers** Mar 1995 v. 50, no. 3. p. 18-20.
- Lawson, Commo Max. "Tending the Mine Field: Sowing and Sweeping: The U.K. is Working to Update Its Capabilities." **Journal of Defense and Diplomacy** Nov 1986 v. 4. p. 53-55.
- Ledbetter, Homer, M. "A Tank Killer -- A Field Plough!" **Armor** Mar-Apr 1972 v. 81. p. 50-51.
- Lee, Harry B.J. "USA Warrant Officers Had Start As Mine Planters." **Officer** Aug 1982 v. 58. p. 34-35.
- Leighow, John K. "Route Clearance Operations." **Infantry** Sept-Oct 1995 v. 85, no. 5. p. 16-22.
- \_\_\_\_\_. "Route-Clearance Operations (Countermining Capabilities)." **Engineer** Aug 1995 v. 25. p. 54-61.

- Levin, V. "Combat Engineers Train to Clear the Way." **Soviet Military Review** Nov 1971 no. 1. p. 18-19.
- Lewis, Mark R. "JRTC (Joint Readiness Training Center) Lessons Learned: An Airborne Platoon in the Defense." **Infantry** Sept-Oct 1993 v. 83, no. 5. p. 42-44.
- Lok, Joris Janssen. "Getting the Full Picture (Detect-Control-Engage Capability)." **Jane's Defence Weekly** Jun 10, 1995 v. 23, no. 23. p. 63-65+
- \_\_\_\_\_. "Upgrade for NATO Mine School." **Jane's Defence Weekly** Jan 29, 1994 v. 21, no. 4. p. 25-26.
- Loretti, Alessandro. "Landmines: Dragon's Teeth: Cause Injury and Death In The World." **World Health** Sept 1995 v. 48, no. 5. p. 14+
- Lowry, Robert. "Uganda's Three-Sided War of Attrition." **Jane's Defence Weekly** September 25, 1996 v. 26. no. 13. p. 41+
- Machmud, Benjamin. "FASCAM (Family of Scatterable Mines) -- The Force Multiplier." **Asian Defence Journal** July 1991 no. 7. p. 32-36.
- Marapoti, James A. "Tactical Mobility and Minefield Breaching." **Marine Corps Gazette** Jan 1988 v. 72. p. 56-62.
- Marsden, James N. "Defeat of Tactical Mine Fields." **National Defense** Sept-Oct 1975 v. 60. p. 127-129.
- Marubbio, Arthur A. "Realistic Training on a Budget: The Device Solution." **Engineer** Nov 1988 v. 19. p. 24-26.
- Matthews, William. "Allied War on Mines Proves Slow and Risky." **Air Force Times** Feb 12, 1996 v. 56, no. 28 p. 18.
- \_\_\_\_\_. "Spring Brings Worries About Mines (in Bosnia)." **Air Force Times** Apr 8, 1996 v. 56, no. 36 p. 8.
- McCall, Jack H, Jr. "Infernal Machines and Hidden Death: International Law and Limits on the Indiscriminate Use of Land Mine Warfare." **The Georgia Journal of International and Comparative Law** 1994 v. 24, no. 2 . p. 229.
- McGee, H.W. "Preparing for Mine Warfare (Exercise Palm Tree). **Marine Corps Gazette** Aug 1978 v. 62. p. 12.

- McHugh, Jane. "New BASIC (Body Armor Set, Individual Countermine) Outfit May Shield Troops From Bosnia Mines." **Army Times** Jan 29, 1996 v. 56, no. 27. p. 16.
- Menzel, Sewall H. "Automatic Ambush." **Armor** Nov-Dec 1970 v. 79. p. 34-35.
- Merchant, Julie M. "Threat Weapons and Weapons Technologies: Implications for Army SOF (Special Operations Forces)." **Special Warfare** July 1994 v. 7, no. 3 p. 32-39.
- Meyer, Deborah G. "Countermine Warfare: Deadly Game of 'Hide and Seek' Using World War II Technology." **Armed Forces Journal International** Mar 1982 v. 119. p. 22+
- Meyer, Gerd. "Long-Range Deployable Mine System." **Military Technology** Oct 1988 v. 12. p. 127-128+
- Miller, David. "Mine Countermeasures Marketplace Awash with Choices." **International Defense Review** Jan 1994 v. 27, no. 1. p. 44-50.
- "Mine Warfare (1) -- The Lessons of Two World Wars." **Defense Update International** Jan 1986 no. 67. p. 12-15+
- "MLRS Phase II AT2 Anti-Tank Mine." **NATO's Sixteen Nations** Special Edition 1990 MLRS Sup 22-23.
- Mulliner, N. "Cambodia: UK's Substantial Contribution." **Army Quarterly & Defence Journal** Jan 1995 v. 125, no. 1. p. 20-29.
- Nash, Trevor. "RO (Royal Ordnance) in Kuwait: The Big Clean-up." **Military Technology** July 1991 v. 15, no. 7. p. 59+
- Naylor, Sean D. "Mine-Clearing Job (in Bosnia) Has Successful Start." **Army Times** Jan 22, 1996 v. 56, no. 26. p. 12-14.
- Nelson, Carl W. et al. "Robotic Mobile Mines Facilitate AirLand Battle 2000 Tactics." **Defense Systems Review** Nov 1983 v. 1. p. 18-22.
- "New Land Mine Countermeasures in Mill." **Armed Forces Journal International** Aug 1974 v. 111. p. 18+
- "New U.S. Land Mine Policy; Statement by President Clinton Followed by a Press Briefing Old Executive Office Building, Washington, May 16, 1996." **Defense Issues** 1996 v. 11, no. 40. p. 1-6.

- Nordwall, Bruce D. "New SAR Images of Bosnia Show Accurate Elevations." **Aviation Week and Space Technology** September 9, 1996 v. 145, no. 11. p. 67+
- Nowicki, John C. "Mines From the Sky." **Armor** Jan-Feb 1974 v. 83. p. 16-17; **Military Engineer** May-June 1974 v. 66. p. 169.
- "Now's Time to Compensate For Years of Neglect -- Mine Countermeasures-Modernization Is A Must." **Officer** Jan 1988 v. 64. p. 18-21.
- Nunes-Vais, Allan R. "A New Dimension in Land Mine Warfare." **Armed Forces Journal International** June 1974 v. 111. p. 18.
- \_\_\_\_\_. "Aggressive Development Program Improves (Land) Mine Warfare Capability." **Defense Management Journal** Oct 1974 v. 10. p. 26-29; Adaptation. **National Defense** Nov-Dec 1974 v. 59. p. 240-242.
- O'Malley, T.J. "Land Mines and Countermeasures -- the Continuing Duel." **Armada International** Dec-Jan 1990-1991 v. 14, no. 2. p. 42+
- \_\_\_\_\_. "Seek and Destroy -- Clearing Mined Land." **Armada International** Feb-Mar 1993 v. 17 no. 1 p. 6-8+
- Parker, Frederick E. "Soviet Countermobility Operations." **Engineer** 1987 v. 17, no. 1. p. 14-15.
- Parker, James M. "Modern AT (Anti-Tank) Mines -- A Real and Lethal Threat." **Armor** May-Jun 1994 v. 103, no. 3. p. 48-49.
- Pearn, John. "Landmines: Time For An International Ban, The United Nations Must End This Indiscriminate Killing and Maiming of Civilians." **British Medical Journal** April 20, 1996 v. 312, no. 7037. p. 990+
- Peebles, Alec A. "British View on American ADSM (Artillery Delivered Scatterable Mines)." **Engineer** July 1990 v. 20. p. 38-45.
- Pendreigh, Kim. "Assistance for Demining in Cambodia." **Insight: Australian Foreign Affairs and Trade** Mar 21, 1995 v. 4, no. 3. p. 17.
- Pengelley, Rupert. "MEDDS (Mechem Explosives and Drug Detection System): Detecting the "Undetectable" Mine." **International Defense Review** Feb 1993 v. 26, no. 2. p. 131-132.
- \_\_\_\_\_. "South Africa Hones Land-Mine Sweeping and Disposal Techniques." **International Defense Review** Feb 1993 v. 26, no. 2. p. 134-135.

- Pochhacker, Christian. "PAP 104 Mine Hunter." **Defense Update International** Nov 1988 no. 91. p. 50-53.
- Pohling-Brown, Pamela. "CMS Goes Clean and Green (in Ordnance and Explosive Waste Disposal)." **International Defense Review** Feb 1993 v. 26, no. 2. p. 132-133.
- Porter, Michael D. "LAVs (Light Armored Vehicles), Snowshoes, and Mine Detectors (USMC's Proactive Focus On Future Combat Needs)." **Sea Power** April 1994 v. 37, no. 4. p. 59-60+
- Powers, Mary Buckner. "Cleaning Up Buried Bombs May Bust Environmental Budget." **ENR** March 6, 1995 v. 234 p. 50-2+
- Pranger, Stephen A. and Kenneth G. Hall. "Demonstrating SMD (Standoff Minefield Detection) Technology." **Engineer** Mar 1989 v. 18. p. 16-17.
- Preston, Antony. "Mine Warfare." **Asian Defence Journal** Dec 1988 no. 12. p. 60-62+
- "Protection of War Victims." **US Department of State Dispatch** Sept 6, 1993 v. 4, no. 36. p. 615-616.
- Purdy, Phil. "AN/PSS-12 Mine Detector: A Proven Performer." **Engineer** Aug 1994 v. 24. p. 20-21.
- Quinn, Woodrow L. Jr. "Dogs in Countermining Warfare." **Infantry** Jul-Aug 1971 v. 61. p. 16-18.
- Ragano, Frank P. "Operation Desert Sweep Ousts Battlefield Waste." **National Defense** Mar 1994 v. 78, no. 496. p. 30-31.
- \_\_\_\_\_. "Operation Desert Sweep (Minesweeping in Kuwait After the Gulf War)." **Military Engineer** Oct 1994 v. 86, no. 566. p. 29-30.
- "Reaffirming U.S. Commitment To Democracy and Reconstruction In Cambodia." **US Department of State Dispatch** Aug 14, 1995 v. 6, no. 33. p. 632-635.
- Reed, Philip L. "One-Hour Minefield -- A Rapid Drill for Combat Engineers or Mechanized Infantry." **Engineer** 1987 v. 17, no. 1. p. 22-24.
- Rhyne, David W. "War in the Lithosphere." **Army** Aug 1986 v. 36. p. 60-64+
- Rider, Bruce. "Obstacle Breaching and Marking For Squads." **Engineer** Oct 1990 v. 20. p. 29-33.

- Roach, J. Ashley. "Certain Conventional Weapons Convention: Arms Control or Humanitarian Law?" **Military Law Review** Summer 1984 no. 105. p. 3-72.
- Robinson, Richard. "Mine Countermeasures: How Much Is Enough?" **Defense System Review** 1985 v. 3, no. 6. p. 37-40.
- \_\_\_\_\_. "Mine Warfare: A Non-Nuclear Strategic Deterrent." **Defense System Review** Nov 1984 no. 2. p. 34-35+
- "Robotics Under Study." **Defense Management Journal** 1st Qrt 1982 v. 18. p. 48.
- Roos, John G. "Hunting Hidden Killers: Most Promising Mine-Detecting Technologies Now on Fast Track." **Armed Forces Journal International** June 1996 v. 133, no. 11. p. 18-19.
- \_\_\_\_\_. "The Unending Menace: Military Countermine Efforts Are No Solution." **Armed Forces Journal International** July 1994 v. 131, no. 12. p. 15-16.
- Ryan, John T. "Tank Mine Clearing Blade: Eagle or Albatross?" **Armor** July-Aug 1994 v. 103, no. 4. p. 26-30.
- Rybicki, John F. "Emerging Mine Warfare Capabilities." **Military Engineer** Nov-Dec 1987 v. 79. p. 574-578.
- \_\_\_\_\_. "Land Mine Warfare and Conventional Deterrence." **NATO's Sixteen Nations** Sept-Oct 1984 v. 29. p. 75+
- Schneck, William. "Desert Storm Countermine Improvisations." **Engineer** July 1992 v. 22. p. 2-7.
- Schneck, William C. et al. "Advances in Mine Warfare: Antitank Weapons." Pt. 3. **Engineer** Nov 1993 v. 23 p. 38-45; Pt. 1 "An Overview" Apr 1993 v. 23. p. 2-7; Pt. 2. "Antipersonnel Mines." Aug 1993 v. 23 p. 26-33.
- Schneck, William C., Jr. and Brian M. Green. "Techniques and Procedures for Route Clearance (Mine-Sweeping Operations)." **Engineer** Mar 1996 v. 26. p. 3-10.
- Schneider, Wolfgang. "MTK-2 Mine-Clearing Tank." **International Defense Review** Sept 1990 v. 23, no. 9. p. 939.
- Selyavin, V. "Artillery Breaches Obstacles." **Soviet Military Review** Aug 1975. no. 8. p. 28-29.
- Shelkin, Michael and J. Philip Purdy. "Counterobstacle Vehicle: An Enhancement to Battlefield Mobility." **Military Engineer** July 1986 v. 78. p. 362-364.

- Shumilov, Pyotr. "Mine-Detection and Clearance Party." **Soviet Military Review** Aug 1987  
no. 8. p. 22-23.
- Sickler, Robert A. "Future Land-Mine Warfare." **Engineer** Mar 1989 v. 18. p. 9-10+
- \_\_\_\_\_. "Mine Warfare For AirLand Battle-Future." **Military Review** Oct 1989 v. 69. p. 42-51.
- \_\_\_\_\_. "Projecting Robotics Technology in Operations Other Than War." **Engineer** Aug 1994  
v. 24. p. 2-9.
- "Smart Weapons Define Tomorrow's Battlefield." **Machine Design** October 26, 1995 v. 67.  
p. 20+
- "Solving Problems in Hazardous Environments." **Defense System Review** 1985 v. 3, no. 6.  
p. 45-47.
- Sommerville, Roger J. "Mobile Obstacle Detachment." **Military Engineer** Pt. 2 Mar-Apr 1989  
v. 81 p. 38-40.
- "Soviet Landmine Operations." **Infantry** Pt.1. May-June 1988 v.78. p. 27-31;  
Pt. 2. July-Aug 1988 v. 78. p. 22-25.
- Spoooner, G.R. "Minewarfare -- Policy or Palsy?" **RUSI Journal of Defense Studies** Mar 1978  
v. 123 p. 52-57.
- Stanley, A.T. "Barriers -- Past, Present, Future." **Military Engineer** May-June 1974 v. 66.  
p. 167-168.
- Starr, Barbara. "A Joint Approach to the Hidden Threat. **Jane's Defence Weekly**  
February 14, 1996 v. 25, no. 7. p. 20+
- \_\_\_\_\_. "Defuzing the World Landmine Threat." **Jane's Defence Weekly** Feb 14, 1996 v. 25,  
no. 7. p. 19-21.
- \_\_\_\_\_. "USA Declares War on Land Mines in Bosnia." **Jane's Defence Weekly** Jan 3, 1996  
v. 25, no. 1. p. 27.
- Starr, Douglas H. "This Land Is Mined Land -- Or Should Be!" **Armor** May-June 1977 v. 86.  
p. 44-48.
- Stinson, David L. et al. "Terrain and Weather Affect Counter mobility." **Military Engineer**  
Aug 1987 v. 79. p. 445-446.

- Stobbs, Emmett E., Jr. and James E. Alty Jr. "Engineering at DNA (Defense Nuclear Agency)." **Military Engineer** Oct 1994 v. 86, no. 566. p. 5-6.
- Stover, Eric; and Dan Charles. "The Killing Minefields of Cambodia." **New Scientist** October 19, 1991 v. 132. p.26-30.
- Strada, Gino. "The Horror of Land Mines." **Scientific American** May 1996 v. 274. p. 40-5.
- Sweeney, Patrick C. "Artillery-Delivery Mines." **Infantry** Nov-Dec 1981 v. 71. p. 42-43.
- Taylor, Carolyn. "Land Mine Warfare Section Provides International Support." **Inscom Journal** Sept 1, 1994 v. 17, no. 9. p. 9.
- Taylor, Kate and Terry L. Gander. "Mine Clearance in Cambodia." **International Defense Review** - Extra February 1, 1996 v. 1, No. 2. p. 5+
- Tesdahl, R. Michael. "Probing for a Solution." **Armor** May-June 1977 v. 86. p. 54-57.
- "They Call It Schiebel. [Advertising Supplement]" **International Defense Review** Oct 1995 v. 28, no. 10. p. 53-56.
- Thomas, Daniel L. "CBU-89 "Gator" Minefield." **Infantry** Jan-Feb 1992 v. 82, no. 1. p.18-19.
- Thomas, F.R. "Employing Tank Mine Rollers and Ploughs." **Armor** Sept-Oct 1985 v. 94. p. 16-17.
- Thorp, A.F. "Countermining." **Military Engineer** Mar-Apr 1971 v. 63. p. 89-90.
- Tillery, G.C. and R.M. Bankey. "Countermine Operations." **Field Artillery** Oct 1987 p. 35-38.
- Tippett, David F. "The BLU-31 mine." **USAF Fighter Weapons Newsletter** March 1970 No. 1. p. 24-26.
- Townsend, James J. "Battlefield Electronics: A Western Edge." **Military Technology** May 1988 v. 12. p. 31-33+
- "Tractors Take On Mine Clearing." **Jane's Defence Weekly** Sept 7, 1991 v. 16, no. 10. p. 428.
- Trinkaas, Hanns Peter. "METEX and FEREX -- State-of-the-Art Hand-Held Mine Detectors." **International Defense Review** 1978 v. 11, No. 9. p. 1482-1484.
- Turbe, Gerard. "GIAT's Rapid Minelaying System." **International Defense Review** Feb 1990 v. 23, no. 2. p. 201-202.



- \_\_\_\_\_. "MACPED Mine Program (Joint Program For An Off-Route Horizontal-Action Anti-Tank Mine)." **International Defense Review** Mar 1990 v. 23, no. 3. p. 311.
- Tusa, Francis. "Lessons From the Gulf War." **Armed Forces Journal International** June 1994 v. 131, no. 11. p. 45.
- "U.S. Initiatives for Demining and Landmine Control." **Defense Trade News** Jul 1, 1994 v. 5, no. 3. p. 4.
- "UH-60A Tested With Volcano Multiple Delivery Mine System." **Aviation Week & Space Technology** March 2, 1987 v. 126. p. 73.
- Van Nortwick, John. "Endsweep." **Marine Corps Gazette** May 1974 v. 58. p. 29-36.
- Vehnekamp, Billy. "Explosive Ordnance Disposal." **Military Engineer** Sept-Oct 1970 v. 62. p. 308-309.
- Walters, Brian. "LIDARS (Light Detection and Ranging System) -- A New Way to Deal With Mines." **Asian Defence Journal** Dec 1995 no. 12. p. 122-123.
- Wandke, Richard D. "TEMAWS (Tactical Effectiveness of Minefields in the Antiarmor Weapons System)." **Armor** Mar-Apr 1981 v. 90. p. 24-26.
- Ware, Walter A. "Mounted Breach -- Making It Work." **Armor** Jan-Feb 1992 v. 101, no. 1. p. 19-23.
- Washecheck, David W. "Operation Salam." **Army** Jan 1991 v. 41, no. 1. p. 37-38.
- Waters, James K. "Countermining Operations in El Salvador." **Engineer** 1987 v. 17, no. 1. p. 29-31.
- Watts, Anthony J. "The Mine -- A Weapon 'In Being'." **Armada International** Nov-Dec. 1982 v. 6. p. 33+
- West, Harold W. "Mine/Countermining Research." **Military Engineer** Aug. 1985 v. 77. p. 472-474.
- Wettern, Desmond. "Mine Countermeasures: Sounding on a Growth Industry." **Military Technology** Feb 1991 v. 15, no. 2. p. 41-42+
- \_\_\_\_\_. "Mine Countermeasures: Forgotten Lessons." **Journal of Defense & Diplomacy** Nov 1988 v. 6. p. 18-21.

- Whaley, Wayne. "Revising the Standard Pattern Minefield." **Engineer** 1987 v. 17, no. 2.  
p. 37-39.
- Williams, Byron J. "Mine Warfare Training." **Infantry** Jul-Aug 1973 v. 63. p. 42-45.
- Williams, E.S. "Only Two Mistakes -- Mine Warfare in Afghanistan." **Armed Forces** Oct 1988  
v. 7. p. 451-452.
- Williford, James R. "Mine Warfare: Too Cost Effective To Keep." **Armed Forces Journal  
International** June 1974 v. 111. p. 20-22.
- Wright, Thomas. "Mobile Obstacles For a Mobile Defence." **NATO's Sixteen Nations** Dec 1989  
v. 34, no. 7. p. 52-55.
- Wyatt, J.R. "Land Minewarfare -- Recent Lessons and Future Trends." **International Defense  
Review** Nov 1989 v. 22. p. 1499-1500+
- Yarovoi, G. "Antimine Defence." **Soviet Military Review** Sept 1974 no. 9. p. 24-25.
- Zhuravlyov, A. "Breaching Obstacles." **Soviet Military Review** Oct 1974 no. 10. p. 42-43.

## **TECHNICAL REPORTS**

Adams, M.S. **In-Minefield Effectiveness Measure for Breaching Vehicles**. Army Mobility Equipment Research and Development Command, Fort Belvoir, VA. : Jun 83. 36p. [This article is from 'Proceedings of the Conference on the Design of Experiments in Army Research Development and Testing (28th) Held at Monterey, California on 20-22 October 1982,' AD-A130 826. p109-144.]

*ABSTRACT: The development of realistic models is required to assess the military worth of countermine systems in mine warfare scenarios. Explicit closed form solutions of delineating countermine equipment effectiveness are being developed to become modular components of a more complex war game modelling mine warfare. This report develops a closed solution to measure the effectiveness of armored vehicles proceeding through cleared lanes. An equation is derived to determine the expected number of mines a vehicle will encounter in a scenario. The expected number of mine encounters is used to calculate a measure to compare the value of changes in tactical methods and countermine materiel. A discussion of the applicability of the effectiveness measure to support mine and countermine studies is also presented. A set of mine warfare situations are formulated as an example of the ease of using the expression derived in this report.*

**ACCESSION NUMBER: ADP001575**

**Advanced Planning Briefing for Industry Proceedings, 15-16 September 1987**. Army Armament Research and Development Center, Dover, NJ. Requirements and Analysis Office.: Sep 87. 176p.

*ABSTRACT: Partial Contents: Soviet Military Power; Mission Area Materiel Plan (MAMP); Technology Trends in Artillery Weapons; Electromagnetic Launch Technology; The Advanced Field Artillery System (AFAS); Manpower and Personnel Integration (MANPRINT) Applied To Future Artillery; Regenerative Liquid Propellant Gun Technology; Advanced Solid Propellants; Shoot-To-Kill/Smart Munitions; Warheads (Including More Powerful Explosives); **Mine Warfare - A Significant Combat Multiplier**; VHSIC Processor For Fire Control/Battlefield Management System; Artificial Intelligence.*

**ACCESSION NUMBER: ADA192152**

**Albert, D.G. Use of an Artificial Snow Platform for WAM Tests.** Special rept. Cold Regions Research and Engineering Lab., Hanover, NH.: Jan 92. 16p.

*ABSTRACT: Because of the lack of a deep snow cover at the February 1991 Wide Area Mine (WAM) ground sensor tests held in Grayling, Michigan, an attempt was made there to simulate the effects of a deeper snow cover by making a pile of snow, compacting it and placing the WAM ground sensor prototype package upon the resulting platform. Recordings of moving military vehicles were then obtained with these sensors. To investigate the effects of this approach, a test was conducted in Hanover, New Hampshire, a few days later under similar snow conditions, but using a simple acoustic source (a pistol firing blank shots) rather than moving vehicles. The Hanover tests are described and reported here. The results show that the use of a small snow platform has little effect on the sensor response, and that the Grayling test procedure would be unsuccessful in simulating the effects of a deeper snow cover. The underlying cause of this failure is that the acoustic effect of a snow cover arises over a large areal extent and cannot be simulated by changing the snow properties in a small area near the sensors.*

**ACCESSION NUMBER: ADA247868**

**Anderson, Alan A. Methodologies for the High Resolution Modeling of Minefield Dynamics.** Master's thesis. Monterey, Calif.: Naval Postgraduate School, Sept. 1991. 182 pgs.

*ABSTRACT: Landmines are a continuing threat to the mobility required by the modern army. Efforts to develop solutions for the problems presented by mines are hampered by a lack of useful, realistic, high resolution models. To assist in developing the needed modeling capabilities, several methodologies are proposed. Methodologies for modeling vehicle navigation error, mine encounters, plow displacement of mines, by passing obstructions and the presence of overwatching direct fires are developed and explained. These methodologies are then implemented using simscript and simgraphics into a minefield breaching model. The model will run in a graphics mode, allowing a visual validation of the model algorithms. The problem of plow width versus breaching force casualty rates is examined as an example of the potential utility of the model.*

**ACCESSION NUMBER: ADA247255**

**Anderson, M.S. Land Mine Warfare - Applying the Principles.** Student essay. Army War Coll., Carlisle Barracks, PA.: 23 Mar 87. 45p.

*ABSTRACT: A historical analysis of land mine warfare repeatedly demonstrated certain principles which when correctly applied yield decisive results. this essay begins by examining the employment of mines in four battles - Alam Halfa, El Alamein, the Golan and the Falklands. It then assess how well our current land mine warfare doctrine, organization and equipment facilitate the timely and sound application of the fundamentals demonstrated by history to today's Airland Battlefield. Areas in which we must improve or change are identified and some new ideas are proposed.*

**ACCESSION NUMBER: ADA182849**

**Army Study Highlights.** Volume 8. Office of the Chief of Staff (Army), Washington, DC. Study Management Office.: Oct 87. 17p. [See also Volume 1, AD-A103 349.]

*ABSTRACT: The Principal Findings: (1) The divisional engineer battalion, working alone, can successfully support the Light Infantry Division (LID) during the initial phase of a short-duration, low-intensity conflict. However, the*

*LID needs immediate Echelon-Above-Division (EAD) augmentation to support extended low-intensity situations and all mid- to high-intensity conflicts. Specific recommendations for theater augmentation units are detailed in the study. (2) The mix of engineer equipment in the current divisional battalion needs to be changed to better align capabilities with the most vital combat requirements. Equipment mix and density recommendations were made that do not increase the C-141 deployment profiles of the LID engineer battalion. (3) The LID will greatly benefit from the fielding of advanced land mining systems. New scatterable and improved conventional mine systems will both increase the range of mobility and countermobility tasks the division can undertake, and substantially reduce the Class IV and V transportation requirements.*

**ACCESSION NUMBER: ADA189213**

**Assessment of Chemical and Biological Sensor Technologies.** National Research Council, Washington, DC. Committee on Chemical and Biological Sensor Technologies.: 1984. 125p.

*ABSTRACT: Chemical and biological warfare agents are divided into three categories: chemical (synthetic compounds), biological (live organisms), and toxins (biologically derived chemical substances). Chemical agents may be subclassified by persistency, degree of toxicity, and physiological effect. Chemical agents can be delivered via rockets, missiles, bombs, artillery shells, sprays, and land mines. Biological agents may be delivered by similar means but may also be used clandestinely. They could be conveniently used to poison water or food supplies, for example. To defend against these agents, sophisticated sensors are required that quickly detect, identify, and monitor very small concentrations. Detection of a chemical agent requires a short response time in order to minimize casualties and a low false alarm rate to maintain credibility. Because the detector will be exposed to high initial concentrations, high sensitivity is relatively less important. Following detection, identification of the agent is essential to deciding what course of action to take. In general, it takes longer to identify than to detect an agent.*

**ACCESSION NUMBER: ADA1434083**

Azevedo, S.G.; et al. **Landmine detection and imaging using Micropower Impulse Radar (MIR).** Lawrence Livermore National Lab., CA. : 7 Aug 95. 8p.

*ABSTRACT: The Lawrence Livermore National Laboratory (LLNL) has developed radar and imaging technologies with potential applications in mine detection by the armed forces and other agencies involved in determining efforts. These new technologies use a patented ultra-wideband (impulse) radar technology that is compact, low-cost, and low power. Designated as Micropower Impulse Radar, these compact, self-contained radars can easily be assembled into arrays to form complete ground penetrating radar imaging systems. LLNL has also developed tomographic reconstruction and signal processing software capable of producing high-resolution 2-D and 3-D images of objects buried in materials like soil or concrete from radar data. Preliminary test results have shown that a radar imaging system using these technologies has the ability to image both metallic and plastic land mine surrogate targets buried in 5 to 10 cm of moist soil. In dry soil, the system can detect buried objects to a depth of 30 cm and more. This report describes our initial test results and plans for future work.*

**REPORT NUMBER: UCRLID121669**

**ACCESSION NUMBER: DE96000870**

**Statement of capabilities: Micropower Impulse Radar (MIR) technology applied to mine detection and imaging.** Lawrence Livermore National Lab., CA.: 13 Mar 95. 14p.

*ABSTRACT: The Lawrence Livermore National Laboratory (LLNL) has developed radar and imaging technologies with potential applications in mine detection by the armed forces and other agencies involved in demining efforts. These new technologies use a patented ultra-wideband (impulse) radar technology that is compact, low-cost, and low power. Designated as Micropower Impulse Radar, these compact, self-contained radars can easily be assembled into arrays to form complete ground penetrating radar imaging systems. LLNL has also developed tomographic reconstruction and signal processing software capable of producing high-resolution 2-D and 3-D images of objects buried in materials like soil or concrete from radar data. Preliminary test results have shown that a radar imaging system using these technologies has the ability to image both metallic and plastic land mine*

surrogate targets buried in 5 to 10 cm of moist soil. In dry soil, the system can detect buried objects to a depth of 30 cm and more. This report describes LLNL's unique capabilities and technologies that can be applied to the demining problem.

**REPORT NUMBER: UCRLID120801**

**ACCESSION NUMBER: DE95017714**

**Balck, H. Translation of Taped Conversation with General Hermann Balck, 12 January 1979 and Brief Biographical Sketch.** Special rept. Battelle Columbus Labs., OH. Tactical Technology Center.: Jan 79. 64p.

*ABSTRACT: This document is a transcript of an interview conducted in 1979 with General Hermann Balck, who served as a Commander of German Panzer Divisions during World War II. The question-and-answer session includes such topics as effectiveness of the U.S., German, and Russian air forces, air-ground tactics, use of mines, German military tradition, armored tactics, armored division organization, reconnaissance, and artillery.*

**ACCESSION NUMBER: ADA160703**

**Ballistic Tests of Armor Materials. Final report on test operations procedure.**

Army Test and Evaluation Command, Aberdeen Proving Ground, MD.: 7 Feb 84. 58p.

*ABSTRACT: This report describes methods available for assessing the ability of armored vehicle armor to provide protection against attacking projectiles and land mines. Tests of the basic armor rather than tests of the vehicle are emphasized.*

**ACCESSION NUMBER: ADA137873**

**Bernhardt, R. and R. Chesney. Description of the DRES (Defence Research Establishment Suffield) Practice Mine Hardware.** Defence Research Establishment Suffield, Ralston (Alberta). : Jul 88. 91p.

*ABSTRACT: The development of scatterable mines and intelligent mine fuzes featuring full width attack capabilities has dramatically changed mine warfare. Unfortunately, not all mine training devices have kept pace with these developments. A distinction must be made at this point between those training mines classified as drill mines and those classified as practice mines. Drill mines are used to train engineer troops to correctly handle mines, while practice mines are used to train non-engineer combat troops about mine warfare. Drill mines therefore simply have to mimic the arming and disarming procedures of the newer types of mines; they do not have to offer all the features of these advanced mines to have some training value. The practice type of training mine, because of its different training role, must emulate all features of the newer mines. However, existing practice mines do not do this; they are, for the most part, unrealistic in form, activation mechanism, and result. Because of this, these devices have little training value, and consequently the troops who encounter them do not fully appreciate the problems associated with mine warfare. Canada. (jes)*

**ACCESSION NUMBER: ADA197999**

**Biddle, S.D., J. Klare, and J. Rosenfeld. Military Utility of Landmines: Implications for Arms Control.** Final rept. Institute for Defense Analyses, Alexandria, VA. : Jun 94. 76p.

*ABSTRACT: This briefing evaluates the military utility of landmines in high intensity, mechanized land warfare and draws implications from this for landmine arms control. While military utility is clearly only one of wide range of issues bearing on the advisability of any particular arms control proposal, it has nevertheless played an unusually important role in the debate to date. While IDA is continuing a broader assessment of this issue, it is hoped that this more narrowly focused analysis will shed some important, if necessary partial, light on that broader debate. The basic conclusion of the briefing is that issues of military utility in high intensity conflict need not preclude further consideration of landmine arms control. A rather demanding set of assumptions and preconditions is required for the military utility of landmines in such conflicts to be so high as to make arms control unworthy of further*

consideration requires as especially demanding set of assumptions about the nature of future warfare. It is far from obvious that the required assumptions can be sustained.

**ACCESSION NUMBER: ADA283061**

**BM 1000 Mines Developed by the German Air Force.** Technical rept.

Naval Technical Mission in Europe. : Oct 45. 38p.

*ABSTRACT: No abstract available.*

**ACCESSION NUMBER: ADA953474**

Briggs, B.D. **General Computer Program for Use in Determining Track Width Plow-Minefield Effectiveness Criteria.** Army Mobility Equipment Research and Development Command, Fort Belvoir, VA. : 1973. 11p. [This article is from 'Proceedings of the Annual U.S. Army Operations Research Symposium (12th), 2-5 October 1973. Volume I,' AD-A125 989.]

*ABSTRACT: The U.S. Army Mobility Equipment Research and Development Center (USAMERDC) has developed a computer program for use in assessing the effectiveness of a track width mine clearing plow moving through an area containing mixed mine types/fuze mechanisms. This program includes important modifications and extensions of some of the methods currently used for obtaining countermeasure-minefield effectiveness criteria and yields statistical information that cannot be determined from other existing models. The approach to this problem makes use of a Monte Carlo computer simulation technique developed at the USAMERDC. Because of a need to investigate current and future threats for ascertaining mine-target interactions within a minefield, the computer program has been written in such a way that the only additional coding required is the so-called threat subroutine, against which the countermeasure effectiveness of the target can be determined. (Author)*

**ACCESSION NUMBER: ADP000613**

Buhl, M.R.; et al. **Dual-band, infrared buried mine detection using a statistical pattern recognition approach.** Lawrence Livermore National Lab., CA.: Aug 93. 39p.

*ABSTRACT: The main objective of this work was to detect surrogate land mines, which were buried in clay and sand, using dual-band, infrared images. A statistical pattern recognition approach was used to achieve this objective. This approach is discussed and results of applying it to real images are given.*

**REPORT NUMBER: UCRLID114838**

**ACCESSION NUMBER: DE93041279**

Campbell, J.G. **Landmine Detection by Scatter Radiation Radiography.** Final rept.

Army Military Personnel Center, Alexandria, VA. : 2 Jul 87. 564p.

*ABSTRACT: The application of scatter radiation radiography to the detection of buried nonmetallic antitank landmines is examined. A combination of calculations and measurements is used to address the problem. The primary calculation tool is a Monte Carlo photon transport code. Measurements are made with an x-ray source, sodium iodide detector, and soil box positioning system. The soil box containing a model of a nonmetallic antitank mine is moved beneath the x-ray source to simulate both the forward motion of a vehicle transporting the detection system and raster of the beam to search a path of sufficient width to allow safe passage. Measurements are used to validate the calculation results for a small detector and produce images of buried mines. The calculations are extended to large area detectors which are required to provide path searches of approximately three widths. Environmental parameters, such as height sensitivity, soil density and moisture content, and inhomogeneities are examined in both calculations and measurements. Calculations are used to suggest mine detection mechanisms and to optimize geometric parameters and x-ray beam quality. Power requirements are also addressed.*

**ACCESSION NUMBER: ADA182227**

Carpenter, R.D., and G.N. Romstedt. **Counterobstacle Vehicle (COV) Utility Study. Volume 1.** Final technical rept. Jan-Apr 86. McLean Research Center, Inc., VA. : May 86. 127p.

*ABSTRACT: The purpose of this study is to identify and evaluate the utility of a single, multi-purpose counterobstacle system on the future battlefield. The study is accomplished by conducting a time-phased analysis of the interrelationship between counterobstacle equipment, missions, and threats over a 30 year period, extending from 20 years ago to 10 years in the future (1965-1995). The analysis involved isolating the counterobstacle mission, by identifying, in priority, the functions performed in accomplishing that mission. A data base was then established listing US Counterobstacle equipment developed and used over the time period, together with the opposing threat capability over the same period. These capabilities were then compared in light of the counterobstacle mission. Wargame analysis was used to show the utility of the counterobstacle system over the timeframe, and to evaluate the utility of a single, multicapable system, called a counterobstacle vehicle (COV) for the future. The findings of the study include the following: - The COV is able to reduce the extra losses that accrue to an attacker from a minefield by one-third. - The COV can improve the chance of successful mission accomplishment of an attacking force by ten percent. .*

**ACCESSION NUMBER: ADA169309**

Carroll, P.W. **Mine and Boobytrap Warfare: Lessons Forgotten.** Study project. Army War Coll., Carlisle Barracks, PA. : 29 Feb 88. 27p.

*ABSTRACT: Low-intensity conflict has brought with it many new training opportunities in the methods of warfare. Considering the probability of involvement at this end of the spectrum of conflict, we must revisit some of the lessons learned over the past wars and take advantage of the experience gained by our friends and allies. This study examines the experience of U.S. forces in three conflicts and tracks the changes in the use of mines and boobytraps in terms of casualties. The experiences of the Thai and Malaysian armies in current hostilities involving mines and boobytraps is also studied. The purpose is to highlight a potential shortfall in our current training emphasis through an examination of history, probability of intensity and current training emphasis.*

**ACCESSION NUMBER: ADA194094**

Charles F.J. **Combat Engineer Equipment: Achilles Heel in the Offense.** Student essay. Army War Coll., Carlisle Barracks, PA. 7 Apr 86. 31p.

*ABSTRACT: There is some question whether or not US Army combat engineers have the equipment necessary to provide mobility support to offensive operations as would be found in Air Land Battle. The current status of engineer equipment and its shortcomings are described. Recent trends in research, development and acquisition of engineer equipment to provide counterobstacle and countermine support on the battlefield are discussed. The inability of engineers to obtain the priority and funds needed to modernize their equipment is attributed to a general lack of understanding and appreciation of the necessity of engineer support in the offense. To counter this condition the need to retain the initiative in the offense, the nature of the Soviet threat, and weaknesses in realistic combat engineer combined arms training are cited. The conclusion is that weaknesses in combat engineering equipment can be overcome only with support of the other combat arms who must carefully weight the risks incurred during offensive operations if engineer equipment does not complement the modernize systems of the combined arms team. (Author)*

**ACCESSION NUMBER: ADA170235**

Chotiros, Nicholas P., et al. **Physics of Buried Mine Detection and Classification.** Final technical rept. Texas Univ. at Austin. Applied Research Labs.: 12 May 95. 15p.

*ABSTRACT: The physics of buried mine detection in offshore sediments and in the surf zone was investigated. Optical techniques are useless because they cannot penetrate sediments while magnetic techniques are of low value because of low resolution, short range, and the introduction of non-magnetic mines. For buried mine detection in the off-shore sediment acoustic penetration at shallow grazing angles was explored. An experiment was conducted jointly with SACLANTCEN to measure sound propagation into a sediment in the 500 Hz to 2 kHz band, and a*

*theoretical fast field model was developed to model the penetration. In the surf zone, where bubble clouds are expected to render acoustic methods unreliable, seismic sonar methods were explored as a means to echo range off buried targets. Tests with controlled pulses revealed that the far-field response was dominated by two interface waves. The results have been very encouraging.*

**ACCESSION NUMBER: ADA294394**

Clark, G.A.; et al. **Computer vision and sensor fusion for detecting buried objects.** Lawrence Livermore National Lab., CA.: Oct 92. 7p. [Annual Asilomar conference on signals, systems, and computers (26th), Pacific Grove, CA (United States), 25-30 Oct 1992.]

*ABSTRACT: Given multiple images of the surface of the earth from dual-band infrared sensors, our system fuses information from the sensors to reduce the effects of clutter and improve the ability to detect buried or surface target sites. Supervised learning pattern classifiers (including neural networks,) are used. We present results of experiments to detect buried land mines from real data, and evaluate the usefulness of fusing information from multiple sensor types. The novelty of the work lies mostly in the combination of the algorithms and their application to the very important and currently unsolved problem of detecting buried land mines from an airborne standoff platform.*

**REPORT NUMBER: UCRLJC112103, CONF92102314**

**ACCESSION NUMBER: DE93012605**

\_\_\_\_\_. **Computer vision for locating buried objects.** Lawrence Livermore National Lab., CA. : Nov 91. 7p. [Asilomar conference on signals, systems and computers, Pacific Grove, CA (United States), 4-6 Nov 1991.]

*ABSTRACT: Given two registered images of the earth, measured with aerial dual-band infrared (IR) sensors, we use advanced computer vision/automatic target recognition techniques to estimate the positions of buried land mines. The images are very difficult to interpret, because of large amounts of clutter. Conventional techniques use single-band imagery and simple correlations. They rely heavily on the judgment of the human doing the interpretation, and give unsatisfactory results with difficult data sets of the type we analyzed. Our automatic algorithms are able to eliminate most of the clutter and give greatly improved indications of regions in the image that could be interpreted as mines. The novelty of our approach lies in the following aspects: (1) a patented data fusion technique using two IR images and physical principles based on Planck's law, (2) a new region-based texture segmentation algorithm using Gabor Transform features and a clustering/thresholding algorithm based on a neural network (Self-Organizing Feature Map), (3) Prior knowledge of measured feasible temperatures and emissivities, and (4) results with real data using buried surrogate mines.*

**REPORT NUMBER: UCRLJC107626, CONF91111012**

**ACCESSION NUMBER: DE92013979**

\_\_\_\_\_. **Data fusion for the detection of buried land mines.** Lawrence Livermore National Lab., CA. : Oct 93. 13p. [International symposium on substance identification technologies, Innsbruck (Austria), 4-8 Oct 1993.]

*ABSTRACT: The authors conducted experiments to demonstrate the enhanced detectability of buried land mines using sensor fusion techniques. Multiple sensors, including imagery, infrared imagery, and ground penetrating radar, have been used to acquire data on a number of buried mines and mine surrogates. The authors present this data along with a discussion of the application of sensor fusion techniques for this particular detection problem. The authors describe the data fusion architecture and discuss some relevant results of these classification methods.*

**REPORT NUMBER: UCRLJC114623, CONF93101649**

**ACCESSION NUMBER: DE94006189**



\_\_\_\_\_. **Detection of buried objects by fusing dual-band infrared images.** Lawrence Livermore National Lab., CA. : Nov 93. 13p. [Institute of Electrical and Electronic Engineers (IEEE) asilomar conference on signals, systems, and computers, Pacific Grove, CA (United States), 1-3 Nov 1993.]

*ABSTRACT: We have conducted experiments to demonstrate the enhanced detectability of buried land mines using sensor fusion techniques. Multiple sensors, including visible imagery, infrared imagery, and ground penetrating radar (GPR), have been used to acquire data on a number of buried mines and mine surrogates. Because the visible wavelength and GPR data are currently incomplete. This paper focuses on the fusion of two-band infrared images. We use feature-level fusion and supervised learning with the probabilistic neural network (PNN) to evaluate detection performance. The novelty of the work lies in the application of advanced target recognition algorithms, the fusion of dual-band infrared images and evaluation of the techniques using two real data sets.*

**REPORT NUMBER: UCRLJC114321, CONF93111355**

**ACCESSION NUMBER: DE94008286**

\_\_\_\_\_. **Land mine detection using multispectral image fusion.** Lawrence Livermore National Lab., CA. : 29 Mar 95. 12p. [Symposium on autonomous vehicles in mine countermeasures, Monterey, CA (United States), 3-7 Apr 1995. ]

*ABSTRACT: Our system fuses information contained in registered images from multiple sensors to reduce the effects of clutter and improve the ability to detect surface and buried land mines. The sensor suite currently consists of a camera that acquires images in six bands (400nm, 500nm, 600nm, 700nm, 800nm and 900nm). Past research has shown that it is extremely difficult to distinguish land mines from background clutter in images obtained from a single sensor. It is hypothesized, however, that information fused from a suite of various sensors is likely to provide better detection reliability, because the suite of sensors detects a variety of physical properties that are more separable in feature space. The materials surrounding the mines can include natural materials (soil, rocks, foliage, water, etc.) and some artifacts. We use a supervised learning pattern recognition approach to detecting the metal and plastic land mines. The overall process consists of four main parts: Preprocessing, feature extraction, feature selection, and classification. These parts are used in a two step process to classify a subimage. We extract features from the images, and use feature selection algorithms to select only the most important features according to their contribution to correct detections. This allows us to save computational complexity and determine which of the spectral bands add value to the detection system. The most important features from the various sensors are fused using a supervised learning pattern classifier (the probabilistic neural network). We present results of experiments to detect land mines from real data collected from an airborne platform, and evaluate the usefulness of fusing feature information from multiple spectral bands.*

**REPORT NUMBER: UCRLJC120710, CONF95041544**

**ACCESSION NUMBER: DE95017825**

\_\_\_\_\_. **Multispectral image fusion for detecting land mines.** Lawrence Livermore National Lab., CA.: Apr 95. 17p. [SPIE international symposium on aerospace/defense sensing and dual-use photonics, Orlando, FL (United States), 17-21 Apr 1995.]

*ABSTRACT: This report details a system which fuses information contained in registered images from multiple sensors to reduce the effects of clutter and improve the ability to detect surface and buried land mines. The sensor suite currently consists of a camera that acquires images in six bands (400nm, 500nm, 600nm, 700nm, 800nm and 900nm). Past research has shown that it is extremely difficult to distinguish land mines from background clutter in images obtained from a single sensor. It is hypothesized, however, that information fused from a suite of various sensors is likely to provide better detection reliability, because the suite of sensors detects a variety of physical properties that are more separable in feature space. The materials surrounding the mines can include natural materials (soil, rocks, foliage, water, etc.) and some artifacts.*

**REPORT NUMBER: UCRLJC120319, CONF95047222**

**ACCESSION NUMBER: DE96002641**

\_\_\_\_\_. **Sensor feature fusion for detecting buried objects.** Lawrence Livermore National Lab., CA.: Apr 93. 13p. [Society of Photo-Optical Instrumentation Engineers (SPIE) OE/aerospace science and sensing meeting, Orlando, FL (United States), 11-16 Apr 1993.]

*ABSTRACT: Given multiple registered images of the earth's surface from dual-band sensors, our system fuses information from the sensors to reduce the effects of clutter and improve the ability to detect buried or surface target sites. The sensor suite currently includes two sensors (5 micron and 10 micron wavelengths) and one ground penetrating radar (GPR) of the wide-band pulsed synthetic aperture type. We use a supervised teaming pattern recognition approach to detect metal and plastic land mines buried in soil. The overall process consists of four main parts: Preprocessing, feature extraction, feature selection, and classification. These parts are used in a two step process to classify a subimage. The first step, referred to as feature selection, determines the features of sub-images which result in the greatest separability among the classes. The second step, image labeling, uses the selected features and the decisions from a pattern classifier to label the regions in the image which are likely to correspond to buried mines. We extract features from the images, and use feature selection algorithms to select only the most important features according to their contribution to correct detections. This allows us to save computational complexity and determine which of the sensors add value to the detection system. The most important features from the various sensors are fused using supervised teaming pattern classifiers (including neural networks). We present results of experiments to detect buried land mines from real data, and evaluate the usefulness of fusing feature information from multiple sensor types, including dual-band infrared and ground penetrating radar. The novelty of the work lies mostly in the combination of the algorithms and their application to the very important and currently unsolved operational problem of detecting buried land mines from an airborne standoff platform.*

**REPORT NUMBER: UCRLJC113727, CONF93044522**

**ACCESSION NUMBER: DE9301866**

Dashcund, D. **IRAAM Wind Tunnel Test.** Task III. Final technical rept. Avco Systems Div., Wilmington, MA.: 30 Aug 83. 63p.

*ABSTRACT: A deceleration, orientation and stabilization system for the deployment of the anti-armor mine (IRAAM) submunition was developed and tested at the Wright-Patterson vertical wind tunnel facility. The system employs a flexible samara airfoil with a tip mass arranged to provide the proper spin rate, descent rate and coning angle. Samara wings of KEVLAR material were fabricated using a flat webbing construction and also a construction consisting of KEVLAR cords enclosed in a nylon envelope. Blades varied in both area and planform aspect ratio. Blade spans ranged from 2.5 to 10.0 inches. Blade widths varied from 2 to 4 inches. All of the IRAAM models used for testing were dimensionally full scale. One model of the nominal configuration was full weight. The other two models were half weight. The tip weight varied up to 5% of the model weight. The test program is outlined. All test procedures and equipment are described. The test results are analyzed and recommendations are made for future developmental studies. (Author)*

**ACCESSION NUMBER: ADA135256**

Dean, A.M., and C.R. Martinson. **Mine Detection Using Non-Sinusoidal Radar. Part 1. Spatial Analysis of Laboratory Test Data.** Special rept. Cold Regions Research and Engineering Lab., Hanover, NH. : Aug 84. 105p.

*ABSTRACT: The interaction among UHF radiation, winter roadway conditions and buried mines was investigated in a refrigerated facility. The near-field spatial return from each target was unique. When the target was not in the near field the spatial return was not at all unique. Cobbles in the medium had little effect, but surface-thawed conditions significantly affected the spatial return, and the reflected signal strength and frequency content. The primary frequency content of the returned signal was either spread over a band broader than that of the transmitted primary frequencies, or completely outside of the primary detection band. We conclude that the complexity of winter*

roadway conditions requires (1) a much broader frequency band than is currently being considered, and (2) a more complex and adaptive background-removal, signal-enhancement scheme than is currently used. Further, more data are required describing the interaction of the winter media, UHF radiation, and buried mines so that adequate detection instrumentation can be developed.

**ACCESSION NUMBER: ADA150471**

Dean, K.J., and J.A. Christians. **Battlefield Related Evaluation and Analysis of Countermining Hardware (BREACH)**. Army Mobility Equipment Research and Development Command, Fort Belvoir, VA.: 1973. 11p. [This article is from 'Proceedings of the Annual U.S. Army Operations Research Symposium (12th), 2-5 October 1973. Volume I,' AD-A125 989. ]

*ABSTRACT: This paper presents the methodology being used at MERDC to describe and evaluate the effectiveness of the integrated family of countermining equipment. The scenarios and hierarchy of models used to determine systems effectiveness and operational feasibilities are described. The essential countermining missions of the Army are examined along with a comparative evaluation of a typical baseline system. (Author)*

**ACCESSION NUMBER: ADP000615**

Del Grande, N. **Sensor fusion methodology for remote detection of buried land mines**. Lawrence Livermore National Lab., CA. : Apr 90. 20p. [National symposium on sensor fusion (3rd), Orlando, FL (USA), 16-20 Apr 1990. ]

*ABSTRACT: We are investigating a sensor fusion methodology for remote detection of buried land mines. Our primary approach is sensor interfusion. Our dual-channel passive IR methodology decouples true (corrected) surface temperature variations of 0.2(degree)C from spatially dependent surface emissivity noise. It produces surface temperature maps showing patterns of conducted heat from buried objects which heat and cool differently from their surroundings. Our methodology exploits Planck's radiation law. It produces separate maps of surface emissivity variations which allow us to reduce false alarms. Our secondary approach is sensor interfusion using other methodologies. For example, an active IR CO(sub 2) laser reflectance channel helps distinguish surface targets unrelated to buried land mines at night when photographic methods are ineffective. Also, the interfusion of ground penetrating radar provides depth information for confirming the site of buried objects. Together with EG&G in Las Vegas, we flew a mission at Nellis AFB using the Daedalus dual-channel (5 and 10 micron) IR scanner mounted on a helicopter platform at an elevation of 60 m above the desert sand. We detected surface temperature patterns associated with buried (inert) land mines covered by as much as 10 cm of dry sand. The respective spatial, spectral, thermal, emissivity and temporal signatures associated with buried targets differed from those associated with surface vegetation, rocks and manmade objects. Our results were consistent with predictions based on the annual Temperature Wave Model. They were confirmed by field measurements. The dual-channel sensor fusion methodology is expected to enhance the capabilities of the military and industrial community for standoff mine detection. Other important potential applications are open skies, drug traffic control and environmental restoration at waste burial sites. 11 figs.*

**REPORT NUMBER: UCRLJC103626, CONF90041881**

**ACCESSION NUMBER: DE90010633**

**Temperature Evaluated Mine Position Survey (TEMPS) application of dual-band infrared methodology**. Lawrence Livermore National Lab., CA.: Mar 90. 20p. [ IRIS Specialty Group meeting on passive sensors and atmospheric physics, Laurel, MD (USA), 13 Mar 1990. ]

*ABSTRACT: We are investigating a temperature evaluated mine position survey (TEMPS) for remote detection of buried land mines. The TEMPS methodology uses two passive IR channels peaked near 5 and 10 microns to decouple temperature from emissivity related effects. The true (corrected) temperature maps show surface temperature variations of 0.2(degree)C. Corrections are made for air-path interference and reflected sky radiation. We exploit a property of Planck's radiation law which applies for small temperature excursions from 288 K. The*

radiant emittance is proportional to emissivity times absolute temperature to the power of (50/wavelength in microns). Our corrected temperature maps show patterns of conducted heat generated by buried objects which heat and cool at different rates than the surrounding materials. These patterns are distinguished from the patterns produced by surface objects. Their respective spatial, spectral, thermal, emissivity and temporal signatures differ. EG & G flew a dual-band IR scanner at 60 m for our demonstration of the TEMPS methodology at Nellis AFB. We detected simulated mine targets covered by 10 cm of dry sand. Optimization of this technology is expected to enhance the capabilities of the military community for standoff mine detection and other applications. 9 refs., 11 figs., 1 tab.

**REPORT NUMBER: UCRLJC103264, CONF9003963**

**ACCESSION NUMBER: DE90009182**

Del Grande, N.K.; et al. **Buried object remote detection technology for law enforcement.**

Lawrence Livermore National Lab., CA.: Mar 91. 28p. [SPIE International Symposium on Optical Engineering and Photonics in Aerospace Sensing, Orlando, FL (USA), 1-5 Apr 1991.]

*ABSTRACT: We have developed a precise airborne temperature-sensing technology to detect buried objects for use by law enforcement. Demonstrations have imaged the sites of buried foundations, walls and trenches; mapped underground waterways and aquifers; and been used to locate underground military objects. Our patented methodology is incorporated in a commercially available, high signal-to-noise, dual-band infrared scanner with real-time, 12-bit digital image processing software and display. Our method creates color-coded images based on surface temperature variations of 0.2 (degrees)C. Unlike other less-sensitive methods, it maps true (corrected) temperatures by removing the (decoupled) surface emissivity mask equivalent to 1(degrees)C or 2(degrees)C; this mask hinders interpretation of apparent (blackbody) temperatures. Once removed, we are able to identify surface temperature patterns from small diffusivity changes at buried object sites which heat and cool differently from their surroundings. Objects made of different materials and buried at different depths are identified by their unique spectra, spatial, thermal, temporal, emissivity and diffusivity signatures. We have successfully located the sites of buried (inert) simulated land mines 0.1 to 0.2 m deep; sod-covered rock pathways alongside dry ditches, deeper than 0.2 m; pavement covered burial trenches and cemetery structures as deep as 0.8 m; and aquifers more than 6 m and less 60 m deep. Our technology could be adapted for drug interdiction and pollution control. 16 refs., 14 figs.*

**REPORT NUMBER: UCRLJC104637, CONF91045013**

**ACCESSION NUMBER: DE91013587**

Delaney, J.E. **Apparatus for Clearing Mines.** Patent. Department of the Navy, Washington, DC.: Filed 4 Jun 92, patented 29 Jun 93. 15p.

*ABSTRACT: An abstract is provided which is capable of clearing encased explosives such as land mines. This apparatus combines a shaped charge jet with a plate penetrator. A depression is formed in a column of a first explosive material. The depression is provided with a metal liner such that detonation of the first explosive material forms a shaped charge jet. The shaped charge jet passes through a hole in a plate penetrator and exits the device without detonating a second explosive material. The shaped charge jet strikes the ground and imparts kinetic energy. As the energy in the shaped charge jet is consumed, the second explosive material detonates and drives the plate penetrator to supersonic velocities. Since shaped charge jet velocity exceeds the detonation velocity of the second explosive material, the shaped charge jet clears a path ahead of the plate penetrator. This results in higher velocity when the plate penetrator impacts the encased explosive, and consequently a greater chance of inducing explosion and neutralization.*

**REPORT NUMBER: PATENT5223666**

DeLony, J.W. **Tactical Mobility and the In-Stride Obstacle Breach: Impossible, Probable, Futuristic.** Army Command and General Staff Coll., Fort Leavenworth, KS. School of Advanced Military Studies.: 29 Nov 88. 72p.

*ABSTRACT: This monograph analyzes the concept of an in-stride breach of an obstacle by a tactical maneuver force. Its focus is on a historical and current review of the tactical doctrines of the U.S. and Soviet armies development of tactics, equipment, and force structure to execute an in-stride breach of an obstacle concurrent to sustaining the momentum of a maneuver force. Given the friction of terrain and combined arms operations, the paper seeks to answer whether the in-stride obstacle breach is possible for either force on today's battlefield. The study begins with a discussion of tactical mobility theory associated with an in-stride obstacle breach. Historical experiences and doctrine for breaching obstacles from World War II are presented for the U.S. and the Soviets. Current doctrine, equipment, and force structure for the two armies are reviewed for analysis and comparisons. Conclusions as to the strengths and weaknesses of each army's capability to conduct an in-stride obstacle breach are made. A final section of recommendations for future U.S. AirLand Battle in-stride obstacle breach operations is presented. (sdw)*

**ACCESSION NUMBER: ADA221445**

**Detection of Remote Minefields Project Plan I.** Environmental Research Inst. of Michigan, Ann Arbor.: 15 Dec 78. 124p.

*ABSTRACT: The objective of the minefield detection project is to determine the effectiveness of remote sensing systems and other methods of detecting and identifying mines, minefields, minelaying equipment, or minelaying operations, and to recommend continuing effort on the most promising this research and development program. This first project plan (Plan I) defines the work to be performed during the contract period with primary emphasis on the first years' effort. The project effort will concentrate on the European Theater of Operations. The terrain of interest is the West German border areas which are generally exemplified by flat plains to the north and rolling terrain to the south. Primary emphasis will be placed on detecting and identifying anti-tank (AT) and anti-vehicular (AV) mines, and will be directed toward hasty mining and minefields associated with tactical offensive operations (i.e., surface mines). Minefields may be detected by both direct observation or by inferential observations, and both approaches will be investigated. Work under the project concerned with each of the concepts to be investigated will be performed in a sequence of four major tasks: (1) identification and screening of promising techniques; (2) preliminary systems analysis and definition of experimental or other data acquisitions systems; (3) acquisition of critical data through experiment, literature survey, or access to SCI; and (4) evaluation of conceptual systems for technical and military usefulness. Four major scenarios for Soviet mine warfare operations have been adopted for analytical purposes.*

**ACCESSION NUMBER: ADA172476**

**Dillencourt-M.B.; et al. Expert System for Minefield Site Prediction. Phase 1.** Annual technical rept. Feb 87-Jan 88. PAR Government Systems Corp., Reston, VA.: Feb 88. 46p.

*ABSTRACT: The software design of the prototype Minefield Site Prediction Expert Systems (MSPES) is described. The ultimate goal of the system is to emulate the role of a terrain analyst in predicting likely mine sites. The major components of the system are the inference system, the geographic information system, and the user interface. The inference system is driven by a goal-directed backward chaining mechanisms. The geographic information system is based on quadtrees. The user interface is menu-driven, and is based on an object-oriented graphics package. This report describes the implementation of the prototype system. It also contains recommendations for the operational system, based on an evaluation of the prototype system. Descriptions of data format conversion capabilities, a detailed description of the geographic processing algorithms, and a complete listing of the rulebase are included as appendices.*

**ACCESSION NUMBER: ADA192990**

**Disposal of Chemical Munitions and Agents.** National Research Council, Washington, DC.: Committee on Demilitarizing Chemical Munitions and Agents, 1984. 234p.

*ABSTRACT: For more than half a century, the United States has maintained a stockpile of highly toxic chemical agents and munitions for possible use in a wartime situation. The United States maintains its stockpile principally to*

deter other countries from using such munitions against U.S. forces. Four basic chemicals are kept. These are the nerve agents VX, which is persistent in its effects, and sarin (GB),\* which is nonpersistent; the mustard agents H, HD, and HT, which are usually referred to simply as H; and the hallucinogenic agent BZ. These chemical agents are stored at eight U.S. Army depots in the Continental United States as well as on Johnston Atoll in the Pacific Ocean. The latter depot was not a part of this study. Each depot varies in size, in the type and number of agents and munitions in storage, and in its proximity to off-site civilian populations. Moreover, the agents are kept in a variety of containers and munitions--rockets, land mines, artillery and mortar shells, bombs and spray tanks, and bulk containers.

**ACCESSION NUMBER: ADA148584**

**Evaluation of Individual Demonstrator Performance at the Unexploded Ordnance Advanced Technology Demonstration Program at Jefferson Proving Ground (Phase I).**

Report for Aug 93-Dec 94. Indian Head, MD: Naval Explosive Ordnance Disposal Technology Center, Indian Head, Mar 95. 194p. Prepared in collaboration with Institute for Defense Analyses, Alexandria, VA

*Abstract: The data contained in this report is a supplement to report SFIM-AEC-ET-CR-94120, "Unexploded Ordnance Advanced Technology Demonstration Program at Jefferson Proving Ground (Phase I)." This report provides a further analysis of the individual demonstrators and the performance of their systems when used to detect, identify and/or remedy buried unexploded ordnance under realistic, controlled conditions.*

**ACCESSION NUMBER ADA295074**

**Expert System to Help Assess Tactical Air Readiness and Capability. Phase 1 Report.**

Synergy, Inc., Washington, DC.: 30 May 86. 97p. [See also Appendices, AD-A173 698 - AD-A173 700. Prepared in cooperation with Systems Research and Applications Corp., Arlington, VA.]

*ABSTRACT: Being built is a demonstration expert system that allows users to ask questions in English about major resources and their effects on U.S. tactical aircraft sorties in central Europe. The system will handle two types of questions. The first are those that require understanding the request, knowing what data bases (if any) to search, searching those data bases, selecting the right piece of information, and presenting the answer to a user in a format he wants. The second type are those questions that require substantive expertise and thinking to answer (i.e., those that require both an intelligent search for information and expert analysis of that information). The demonstration system will answer questions drawing on 6 types of information: 1) Characteristics of U.S. tactical aircraft in Europe; 2) The specific missions those aircrafts fly; 3) The number and type of conventional munitions associated with U.S. tactical aircraft; 4) Availability of and POL requirements for U.S. tactical aircraft; 5) Aircrew status and availability; and 6) Status and descriptions of 4 U.S. tactical airfields (Spangdahlem, Bitburg, Hahn, Ramstein).*

**ACCESSION NUMBER: ADA173697**

Fitch, V.L., and L. Lederman. **Air-Sown Mines for the Massive Barrier.** Research paper. Institute for Defense Analyses, Alexandria, VA. Jason Div.: May 67. 7p.

*ABSTRACT: A discussion of a series of air-sown mines designed to complement the use of gravel mines and to be sown densely along wider trails and roads is presented. The basic design is a pencil-shaped, fin-stabilized device which would be capable of soil penetration to a predetermined depth, so that a plunger-activator projects just slightly above the trail surface. The objective is to produce a system of cheap, small devices that would present a formidable barrier to infiltration and would be difficult to counter. (Author)*

**ACCESSION NUMBER: AD383442**

Fitzsimmons, F. **FASCOM Soldering Process Control Evaluation.** Final rept.

Battelle Columbus Labs., OH.: 31 Dec 82. 18p.

*ABSTRACT: Based upon observations of the manufacturing processes at Honeywell, Inc., New Brighton, MN and Aerojet Corp., Downey, CA, the writer feels that certain major activities must be performed to ensure minimum risk and maximum reliability of the finished product. The recommendations contained in this report will promote similarity in FASCAM products. ADAM and RAAM are both delivered to target in basically the same manner; both are expected to face the same stress conditions in storage and in use. Therefore, there should be a single, unified standard of workmanship for FASCAM products.*

**ACCESSION NUMBER: ADA164194**

Gambiez, G. **Should We Fear Mine Warfare.** Study project. Army War Coll., Carlisle Barracks, PA.: 30 Mar 89. 44p.

*ABSTRACT: Mines are weapons. Thanks to the improvements allowed by electronics they become more and more efficient and cost effective. On land as well as at sea, they would be widely used at theater level by all belligerents in all types of conflicts. Unfortunately improvements in mine countermeasures are more difficult to realize and to use on the field. The nations of the free world should increase their efforts in the domain of those countermeasure systems, or they risk being the first victims of the increasing advances in mines and mine delivery systems. The problem is as difficult as urgent. Keywords: Land mines, Underwater mines. (GC/AW)*

**ACCESSION NUMBER: ADA209180**

Garland, M.W. **KHAFJI: A Combat Simulation.** Master's thesis. Naval Postgraduate School, Monterey, CA.: Sep 91. 137p.

*ABSTRACT: This thesis presents a high resolution, discrete event driven combat simulation. This model was developed to facilitate the analysis of tactical options available to a small unit (company/platoon) commander using artillery and multiple lanes in overcoming a minefield obstacle. KHAFJI is a high fidelity combat simulation written in SIMSCRIPT 11.5 with SIMGRAPHICS I. Employing user input parameters which define a minefield scenario, the model generates output which enables the user to compare various tactical options available to maneuver commander in crossing a minefield. By using menu driven input screens, the user has a choice of multiple crossing lanes, size of crossing force, distribution of forces upon crossing lanes, multiple mine belts, and use of indirect fires against the minefield. Using SIMGRAPHICS I software, KHAFJI displays the minefield and the unit as it crosses the minefield. KHAFJI depicts each mine, each member of the crossing unit, and each impacting artillery round. The graphics provided by KHAFJI allows the user to see the crossing as it unfolds, thereby, reinforcing user confidence in the resultant data. When running multiple replications, graphics can be turned off to speed processing. An example of the type of analysis that can be performed with KHAFJI is presented in Chapter IV.*

**ACCESSION NUMBER: ADA245170**

Gavel, D.T.; et al. **Impulse radar array for detecting land mines.** Lawrence Livermore National Lab., CA.: 3 Apr 95. 12p. [Symposium on autonomous vehicles in mine countermeasures, Monterey, CA (United States), 3-7 Apr 1995.]

*ABSTRACT: The Lawrence Livermore National Laboratory has developed radar and imaging technologies with potential application in demining efforts. A patented wideband (impulse) radar that is very compact, very low cost, and very low power, has been demonstrated in test fields to be able to detect and image nonmetallic land mines buried in 2-10 cm of soil. The scheme takes advantage of the very short radar impulses and the ability to form a large synthetic aperture with many small individual units, to generate high resolution 2-D or 3-D tomographic images of the mine and surrounding ground. Radar range calculations predict that a vehicle-mounted or man-carried system is quite feasible using this technology. This paper presents the results of field tests using a prototype unit and describes practical mine detection system concepts. Predicted capabilities in terms of stand-off range and radiated power requirements are discussed.*

**REPORT NUMBER: UCRLJC120550, CONF95041543**

**ACCESSION NUMBER: DE95017847**

**Graham, W.J. Focused Synthetic Microwave Array for Mine Detection and Imaging.** Final rept. 3 Jun-3 Dec 91. Graham Research, Bensalem, PA.: 3 Dec 91. 85p.

*ABSTRACT: This report presents the results of a feasibility study of a proposed focused synthetic rectangular array for microwave detection and imaging of mines. The proposed techniques uses a bistatic antenna system with transmitter and receiver located at the angles of incidence and reflection, respectively of the radiation illuminating the ground. These angles are equal to the Brewster angle of the ground medium so that ground reflections are minimized for vertical polarization. The transmit antenna has a broad beam which illuminates the field of view on the ground. The receiver antenna is a horizontal line array, which forms a rectangular synthetic array by the forward motion of the system. The results of an analytical study are presented, and experimental results are described which give high resolution three-dimensional images of various types of buried anti-tank mines. A system design for a focused rectangular synthetic counter mine array is also given. A design of an experimental system for Phase II and a test plan is described.*

**ACCESSION NUMBER: ADA245850**

**Granuzzo, J.P. Performance Oriented Packaging (POP) Testing Packaging for Ground Emplaced Mines (i.e., M74, M75 and M79 Mines).** Final rept. DoD Performance Oriented Packaging of Hazardous Materials, Washington, DC.: 24 Mar 94. 6p.

*ABSTRACT: This report contains the tests performed and test results on the Ground. Emplaced Mines (i.e., M74, M75 and M79 Mines) that are packed 40 mines per metal ammunition container IAW drawing number 9243805 for Performance Oriented Packaging Certification.*

**ACCESSION NUMBER: ADA277849**

**Groot, J.S. and Y.H. Janssen. Remote Land Mine(Field) Detection: An Overview of Techniques.** Physics and Electronics Lab. RVO-TNO, The Hague (Netherlands).: Sep 94. 52p.

*ABSTRACT: A near real time land mine(field) detection system is essential for military commanders to enable them to circumvent the mines, or to allocate/employ mine neutralisation/breaching assist to clear a safe route through a minefield. Basic principles and strengths and weaknesses of such a system with visual, near infrared, midwave infrared, longwave infrared, microwave radiometric and radar sensors are presented. Recommendations for a vehicle mounted multi-sensor demonstrator system are given since the Genie expressed its interest in such a system, it is cheaper than an aircraft mounted system and because sensor fusion can be tested and applied relatively easy on such a system. Promising techniques for a vehicle mounted detection system are: (1) passive and active infrared imaging, (2) microwave radiometry, (3) passive and active visual and near infrared wavelength discrimination, (4) radar ground and vegetation penetration. Proposed steps in the development of a vehicle mounted mine detection demonstration system are a feasibility study, tower measurements and design, construction and testing of the demonstrator.*

**ACCESSION NUMBER: ADA288635**

**INTERNET <http://www.dtic.mil/dtic/review/a288635.pdf>**

**Ground Penetrating Radar for Ordnance Contaminated Site Restoration.** Indian Head, MD: Naval Explosive Ordnance Disposal Technology Center, Mar 95. 348p.

*Abstract: The main purpose of this document is to apply ground penetrating radar (GPR) technology to the problem of locating and identifying buried ordnance at military sites. The emphasis of the research applied GPR technology to an airborne system that will allow very large parcels of land to be processed. This contract represents one portion of an overall U.S Government program to clear former and present military ordnance ranges of all unexploded ordnance and other buried devices that pose a threat to the public.*

**ACCESSION NUMBER ADA295153**



Guadagno, J.; et al. **Radiation Protection Safety Protocol for Industrial X-Ray Backscatter Radiography Experiments.** Final rept. Army Belvoir Research Development and Engineering Center, Fort Belvoir, VA.: Nov 90. 30p.

*ABSTRACT: Scattered radiation has been used in medical and engineering applications to determine properties and form images of irradiated objects. Scattered radiation is ideally suited to the geometry of mine detection which depends upon differences between the number of photons scattered from mines and soil to produce an image as opposed to conventional radiography which uses the transmission of photons through an irradiated object to produce an image. Mine detection through backscatter radiation measures the amount of radiation that is backscattered from the ground to a NaI detector which is mounted next to the x-ray source. To generate sufficient backscatter radiation to image buried land mines, an industrial x-ray unit must be operated continuously at or above 150 kVp for 2 to 3 hours. Operating an industrial x-ray unit at this level and duration for the purpose of mine detection requires a complete radiological review of both the exposure room and the x-ray unit itself. (JS)*

**ACCESSION NUMBER: ADA229740**

Gupta, A.D. **Structural Analysis of a Mine with Two Viscoelastic Explosive Fills.**

Army Armament Research and Development Command, Aberdeen Proving Ground, MD.

Ballistic Research Lab.: Feb 83. 25p. [This article is from 'Transactions of the Conference of Army Mathematicians (28th) Held at Bethesda, Maryland on 28-30 June 1982,' AD-A128 683.]

*ABSTRACT: The structural response of a Soviet TM-46 land mine with two viscoelastic explosive fills subjected to an externally applied pressure wave has been analyzed with the ADINA finite element code. The main charge consists of 5.72 kg TNT while the booster charge in the fuze contains .04 kg Tetryl in the fuze well. The finite element model of the mine uses the axisymmetric two-dimensional mesh configuration with a rigid base support boundary condition. Both implicit and explicit time integration schemes have been used for this analysis.*

**ACCESSION NUMBER: ADP001035**

Hanson, J.V.; et al. **Mine Detection in Dry Soils Using Radar.** Army Topographic Engineering Center, Fort Belvoir, VA.: 17 Mar 92. 16p.

*ABSTRACT: The detection of mines and subsurface ordnance continues to present a challenging problem for both the Army and U.S. Marine Corps. An initiative was launched by the Army's Topographic Engineering Center (TEC) to determine the feasibility of using penetrating radars to detect subsurface objects in very dry soils. A test site was selected at Twenty-nine Palms, CA, and soil samples were collected and analyzed. The soils were very dry, containing on average less than 2 percent moisture, and consist mainly of fine sand with some gravel. An analysis of soils collected in the Middle East showed they were sufficiently comparable for the demonstration. A minefield test site was constructed reflecting known doctrine and combat engineering practices. Metallic and nonmetallic mines were emplaced on the surface and at varying depths. Corner reflectors were placed around the test site, both on the surface as well as underground. Overflights were conducted utilizing X-, C- and L- band radars. ground-penetrating radar, arid regions, mines, minefields, synthetic aperture radar (SAR).*

**ACCESSION NUMBER: ADA254259**

Healey, Anthony J., and William T. Webber. **Sensors for the Detection of Land-Based Munitions.** Technical rept. Naval Postgraduate School, Monterey, CA. Dept. of Mechanical Engineering.: 18 Sep 95. 29p.

*ABSTRACT: This report provides a summary of current land-based munition detection sensor development. Sensors are categorized based upon the principle of their operation: electromagnetic, conductive, mechanical, optical, acoustic, and chemical. Each category is subdivided into particular operational sensor types. Theory of operation for each particular sensor type is provided, as well as a discussion of advantages and disadvantages of each. A*

*discussion of sensor performance is included. The final section of the report is a survey of commercially available munition detection sensors along with comments concerning their performance.*

**ACCESSION NUMBER: ADA300930**

**INTERNET <http://www.dtic.mil/dtic/review/a300930.pdf>**

Held, M. **Anti Tank Mines.** Messerschmitt-Boelkow-Blohm G.m.b.H., Munich (Germany, F.R.). Information und Dokumentation.: 1984. 21p. [ International Seminar on Defence Technology, Rawalpindi (Pakistan), 28 Nov 1984. ]

*ABSTRACT: According to the method of deployment and to the mechanism of performance types of anti-Tank mines are reviewed. There is given an overview about 3 generations of mines. According to the mode of action and to the principle of function the mines are classified. Examples of modern anti-tank mines and pictures are presented.*

**ACCESSION NUMBER: TIBB8680835**

Janzon, B. **International Workshop of Technical Experts on Ordnance Recovery and Disposal in the Framework of International Demining Operations.** Held in Stockholm, Sweden on June 8-10, 1994. Foersvarets Forskningsanstalt, Stockholm (Sweden). Dept. of Weapons and Protection.: Sep 94. 46p.

*ABSTRACT: The Workshop was arranged by FOA, the National Defence Research Establishment of Sweden, as a result of discussions with the United Nation's Under-Secretary General for Human Affairs, with the UN Coordinator for Demining Operations, and with the Government of Sweden. The purpose of this workshop was to be a forum for the exchange of information, identification of problems and possible means of solving them, and specification of principle requirements on new systems and methods, within the general areas of mine and other ordnance detection, recovery and disposal, particularly in connection with demining operations.*

**ACCESSION NUMBER: PB95222907**

Jessl, P., and W. Koeppel. **Development of Environmental Support on Mine Detection Techniques.** Special rept. no. 1, Jun-Jul 83. Battelle-Inst. e.V., Frankfurt am Main (Germany, F.R.): Jul 83. 17p.

*ABSTRACT: Terrain factor maps have been established for the following data: land-use (basic information); crop type; crop/vegetation height; and crop/vegetation condition. A continuous flight line map at the scale 1:2.500 (600' flight height) plus single overlays (M=1:500, 300' flight height) were prepared in detail. As the meteorological data and also interviews clearly indicate, 1982 had extremely dry summer conditions. Thus, all beef-raising crops (pastures, rape, etc.) and also truck crops yielded quite good crops. It was sometimes difficult to identify characteristic differences between beef-raising crops and meadows/pastures because of the extremely poor crop conditions of these areas (which resulted in untypical colours and textures).*

**ACCESSION NUMBER: ADA132761**

Johnson, J.H.; et al. **Oxalate Ester Chemiluminescence, Improved Low Temperature Formulations.** Final technical rept. Jul 83-Sep 84. Naval Weapons Center, China Lake, CA.

*ABSTRACT: The objective of the program was to develop and test new chemiluminescent formulations which were usable at lower temperatures than the systems currently in use. The visibility requirements included a minimum visual range of 10 meters for 30 minutes at -25 degrees F or lower. The oxalate ester-hydrogen peroxide chemiluminescent system was used. A series of new formulations were developed which offer reduced temperature sensitivity in a variety of colors. The formulations were tested at Ft. Greely, Alaska, where the program objectives were met and exceeded. (Mine clearance).*

**ACCESSION NUMBER: ADA157899**

Johnson, John V., et al. **Project Ostrich, A Feasibility Study: Detecting Buried Mines in Dry Soils Using Synthetic Aperture Radar.** Technical Report, Sep 90-May 93. Fort Belvoir, VA: Army Topographic Engineering Center, Sep 93. 108p.

*Abstract: Metallic and nonmetallic mines were utilized to construct a mine field in arid soil at Twenty-nine Palms, California to assess the extent to which long-wavelength radar could be used to detect buried mines by remote sensing. Surface and subsurface mines were placed in accordance with known enemy doctrine, and the site was imaged with X\_J C\_ and L-band radar from a Navy P-3 aircraft. This report describes the construction and physical characteristics of the test sites, and presents and discusses the results of imagery analysis.*

**ACCESSION NUMBER: ADA274141**

Kieft, L.J., and D.L. Bowman. **Sensitivity Evaluation of M15 and Analog Mines.** Final rept. Oct 89-Jun 90. Army Ballistic Research Lab., Aberdeen Proving Ground, MD.: Sep 90. 27p.

*ABSTRACT: This study analyzes the explosive destruction or deactivation of land mines. Computer modeling was used extensively to calculate and predict mine initiation. In order to facilitate comparisons between modeling predictions and experimental data, mine analogs were made. These analogs were intended to represent actual mines in their sensitivity to initiation by explosive countermeasures. In reality, the analog mines were found to be somewhat more sensitive than had been predicted by computer modeling, and thus might not accurately represent the M15 mine. To determine the reasons for this discrepancy in sensitivity, four analog mines and one M15 mine were sawed open and their contents analyzed. It was found that there are definite physical differences between the analog mines and the M15 which could account for this sensitivity difference. The differences are metal thickness, void structure, interfacial voids, and variations except void structure were in the direction of causing an increase in sensitivity of the analog mines as compared with that of the M15 mine.*

**ACCESSION NUMBER: ADA226489**

Kimmit, M.T. **Rethinking FASCAM (Family of Scatterable Mines) Principles for the Use of Artillery Delivered Mines.** Army Command and General Staff Coll., Fort Leavenworth, KS. School of Advanced Military Studies: 18 Nov 88. 65p.

*ABSTRACT: This monograph addresses existing shortcomings in the principles for employment of scatterable and remotely delivered mines. Such mines, part of an overall revolution in the conduct of land mine warfare, are an integral component of the deep, close and rear battlefields. Yet, the doctrine and principles of these mines has not kept pace with the advances in land mine technology. One area in which this is abundantly clear is in the use of Field Artillery weapon systems to deliver scatterable mines. While the Field Artillery has made great advances in the development and integration of such systems as precision guided munitions and advanced artillery data technology, the RAAM (Remote Anti-Armor Mine) and ADAM (Area Denial Artillery Munition) systems lack adequate doctrine and principles to fully exploit their potential on the battlefield. In schoolhouse exercises, and FTX's worldwide, the lack of such doctrine is reflected in ad hoc, highly personal approaches to FASCAM (Family of Scatterable Mines) employment. While the lack of any wartime testing of these systems precludes definitive doctrine on the subject, most often these systems are employed without fully understanding their potential or shortcomings. The author argues for the development of thorough and consistent doctrine for the use of artillery scatterable mines. As one component in a 'Triad' of delivery systems, the artillery may be the most responsive and flexible leg of that triad, but it is also the most vulnerable. (KR)*

**ACCESSION NUMBER: ADA210973**

Korjack, T.A. **Two-Dimensional Finite Difference Time Domain (FD-TD) Model of Electromagnetic (EM) Scattering From a Buried Rectangular Object.** Final rept. Jun 93-Jun 94. Army Research Lab., Aberdeen Proving Ground, MD. : Feb 95. 36p.

*ABSTRACT: A two-dimensional transverse-magnetic (TM) electromagnetic (EM) scattering problem from buried dielectric objects due to a Gaussian pulse is numerically solved using the Finite Difference Time Domain (FD-TD)*

method with absorbing boundary conditions via Maxwell's equations. The scatterers are rectangular cross sections in a multilayer media; the Gaussian pulse is reflected into a lossy earth by a finite, 450 plate that is part of the detector that receives the EM signal. Spatial distributions of electric field components are calculated over time for single and multiple land scatterers (mines). The scattered fields gradually diminish with time and are then eventually dissipated. Carpet plots are illustrated to depict the spatial distributions of the scattered field component at comparative time steps for one, two, and three distinct scatterers or land mines within the lossy media. Results clearly illustrate the typical wave patterns expected under the simulated conditions as presented in this report - i.e., conductivity ( $s$ ) for the air is 0, conductivity for the earth is 0.01, conductivity for the grass is 0.005, and conductivity for the mines are 0, 0.02, and 0.008; permeability values ranged from 1 for air, 9 for earth, 5.5 for grass, and 2.3, 5.6, and 23.0 for the mines, respectively. Numerical analysis indicates that the difference of scattered signals between single and multiple scatterers are considerably obvious from the point of view of both time domain and frequency domain. (AN).

**ACCESSION NUMBER: ADA293685**

Kovel, Steven, and John Brand. **Research Support for the Depth and Simultaneous Attack Battle Lab**. Final rept. Jan-Dec 94. Army Research Lab., Adelphi, MD.: Jan 95. 68p.

*ABSTRACT: We performed an assessment of the 6.1/6.2 sensor technology programs that support four of the operational capability requirements (OCRs) related to real-time targeting, formulated by the Depth and Simultaneous Attack Battle Lab. The assessment focused on (1) how the research programs support the OCRs and (2) which research programs are required to support each OCR. Four programs were found to have the greatest potential for supporting the OCRs: Automatic Target Detection-Recognition- Identification, Radar Sensor and Signature Research, Smart Mines Sensor System, and Ultra-Wideband Foliage-Penetrating Synthetic Aperture Radar. These programs were selected based on the information generated by these sensor technologies. In addition, we identified the need for realistic war game simulations that incorporate these sensor program concepts, in order to quantitatively evaluate the concepts. In assessing the support required by the OCRs, we found that automatic target recognition was least mature link, and we recommend that the greatest effort be in developing this technology. Finally, we found that the battlefield damage assessment OCR requires a clearer definition before a technology assessment can be performed.*

**ACCESSION NUMBER: ADA289874**

Lehowicz, L.G.; et al. **Analysis of Scatterable Mine Doctrine**. Study project. Army War Coll., Carlisle Barracks, PA.: 2 Jun 83. 73p.

*ABSTRACT: This study summarizes the capabilities, strengths, and limitations of scatterable mine systems; analyzes the doctrine concerning scatterable mine battlefield employment, command, and control; establishes some proposed guidelines for the employment of scatterable mines in support of a main battle area defense against a Soviet/Warsaw Pact attack into Western Europe; and provides some broad conclusions on the integration of scatterable mines onto the modern battlefield. Scatterable mines offer the Army and Air Force a powerful means to counter the battlefield mobility of any potential armored or mechanized enemy. However, the maneuver doctrine described in the Airland Battle concept reinforces the requirement to preserve the full freedom of movement for friendly forces. A balance must be struck between these two competing demands. That balance can be attained by viewing scatterable mines as several distinct munitions, which are emplaced by different delivery systems and have unique strengths and weakness.*

**ACCESSION NUMBER: ADA131659**

Lindsey, G.R. **Battlefield of the 1990s**. Memorandum rept. Operational Research and Analysis Establishment, Ottawa (Ontario): Dec 82. 19p.

*ABSTRACT: While the new weapons likely to appear on the battlefields of the 1990s will add formidable capabilities, some will be offset by direct countermeasures and others by the effects of properly integrated combined arms tactics. There will be important improvements to ground-based air defence weapons, to air-to-ground*

*weapons, to anti-tank guided missiles, to land mines, and to anti-personnel weapons. Dominant features of the 1990s will be electronic warfare, fast movement, and the rapid expenditure of ammunition. (Author)*

**ACCESSION NUMBER: ADA126587**

**McIntosh, A.C., Jr. MIL-STD-1660 Test of XM87 and XM8 Volcano Mine Pallet.** Savanna, IL: Army Defense Ammunition Center and School, Evaluation Div., March 1987. 20 pgs.

*ABSTRACT: The U.S. Army Defense Ammunition Center and School (USADACS), Evaluation Division (SMCAC-DEV, has been tasked by the U.S. Army Armament Research, Development and Engineering Center (SMCAR-AEP), Picatinny Arsenal, NJ, to design, fabricated, and test a metal pallet for the PA113 Volcano Mine Cannister. This engineering report contains the results of the MIL-STD-1660 pallet testing sequence of the palletized PA113 Volcano Mine Cannister. As a result of these tests, recommendations to strengthen the pallet and modify the PA113 bundling procedure evolved.*

**ACCESSION NUMBER: ADA207182**

**Mei, K.K. Electromagnetic Wave Scattering by Partially-Buried Metallic and Dielectric Objects.** Final rept. California Univ., Berkeley. Electronics Research Lab.: Mar 84. 20p.

*ABSTRACT: The objective of this research is to study the feasibility of computing electromagnetic wave scattering by objects which are buried or partially buried in a lossy ground. The datas obtained through computer solutions of the related Maxwell's Equations can be applied to detection of plastic land mines, tunnels and natural resources. The method used in this investigation is based on the Unimoment method, a unique hybrid of analytical and numerical methods. The extension of the method to include lossy ground half-space was made possible by the development of special eigenfunctions which include the continuity of the air-ground interface. Results were obtained for scattering by buried body of revolution, buried body of revolution with arbitrary orientation and two-body scattering.*

**ACCESSION NUMBER: ADA140109**

**Mei, K.K., and T.M. Kvam. Numerical Parametric Study of Electromagnetic Wave Scattering by Buried Dielectric Land Mines.** Final rept. Geo Electromagnetics, Inc., Berkeley, CA.: 1983. 95p.

*ABSTRACT: The unimoment method is applied to solve the electromagnetic scattering by a buried dielectric finite cylinder simulating a land mine. Computed results are reported at frequencies from 400 MHz to 1400 MHz at 100 MHz intervals. The dielectric constants of the ground are considered to be dispersive which simulates soil with 5%, 10% and 20% water content. Results are computed for the scattered electric and magnetic fields which are presented in terms of the cylindrical components of E and noH at a distance of 1 in. to 4 in. above the ground at 1 in. intervals. The numerical results are computed along the positive x-axis for each azimuthal mode. The fields at points on the positive x-axis may be obtained by summing the modal fields directly. Fields at points other than the positive x-axis may be obtained by summing the modal fields multiplied by the proper azimuthal function. Sample results are given in the report and the complete data are stored on magnetic tape. This report include documentation for the tapes.*

**ACCESSION NUMBER: ADA124980**

**Messinger, M. Mixed Minefield Modeling.** Picatinny Arsenal, Dover, NJ.: 1973. 17p. [This article is from 'Proceedings of the Annual U.S. Army Operations Research Symposium (12th), 2-5 October 1973. Volume I,' AD-A125 989.]

*ABSTRACT: The purpose of this section is to present a model for analyzing the effectiveness of mine clearing plows mounted in front of the tracks of a tank in a AM minefield. The plow's function is to sweep AM mines away from the path of the tank's tracks thereby preventing a track - AM mine contact, thus increasing the tank's survivability. The minefield to be considered consists of a mixture of AM munitions with three different types of fuzes; anti-handling*

(AH), pressure (PR), long impulse (LI). AH munitions will almost certainly be detonated upon contact with the plow whereas PR and LI munitions will usually be pushed aside without detonation. A major purpose of employing AH munitions in the minefield is to countermeasure plows.

**ACCESSION NUMBER: ADP000614**

Metz, C.D. et al. **Recent Developments in Tactical Unmanned Ground Vehicles**. San Diego, CA: Naval Command Control and Ocean Surveillance Center, RDT&E Division, Jun 93. 9p. [Availability: Pub. In Proceedings AUVS-92, 19th Annual Technical Symposium and Exhibition, 22 Jun 92.]

*Abstract: Unmanned ground vehicles have long been envisioned in battlefield support roles involving reconnaissance, surveillance, target acquisitions and NBC and mine detection. Appropriate utilization of robotic vehicles for these tasks can be an effective force multiplier and an enhancement to soldier survivability. Over the past six years there has been substantial progress in the development of prototype unmanned ground vehicles for use by the Army and the Marine Corps. This paper looks at several versions of tactical unmanned ground vehicles and discusses technical issues with respect to remote platforms, mission modules and control units.*

**ACCESSION NUMBER: ADA266171**

**Mines and Demolitions**. Final rept. Army Test and Evaluation Command, Aberdeen Proving Ground, MD.: 29 Apr 83. 24p. [Supersedes report dated 22 Apr 74, AD-A031 850.]

*ABSTRACT: Provides tests for evaluating the performance characteristics of mines and demolitions. Describes safety evaluation, supplementary environmental and shock tests, and tests for weathering, fuze functioning, mine/fuze compatibility, effectiveness, bullet impact, blast sensitivity, sympathetic detonation, and parachute delivery. Discusses reliability, human factors and maintenance evaluations. Describes equipment and technique for determining burst height of bounding mines. Tabulates mine types and applications and physical characteristics of explosives. Not applicable to chemical mines. (Author)*

**ACCESSION NUMBER: ADA127777**

Moler, Robert B. **Nuclear and Atomic Methods of Mine Detection**. Technical rept. Army Belvoir Research Development and Engineering Center, Fort Belvoir, VA.: 1 Nov 91. 40p.

*ABSTRACT: This report summarizes the results of a project to provide technical review and analysis, developmental assessments, and studies of current and new technology applicable to the detection of landmines using nuclear and atomic techniques. Additionally, technical support for new research initiatives was provided in the form of independent analytical studies that sought to verify expectations and predictions for a range of techniques, including neutron capture, gamma ray induced reactions on nitrogen (an important element in military explosives), neutron elastic and inelastic scatter, gamma ray nuclear resonance scattering on nitrogen, x-ray backscatter imaging, dual energy x-ray Compton scattering, and nuclear magnetic resonance. For relatively mature technologies such as x-ray backscatter imaging, thermal neutron capture, and the reaction of nitrogen with 13.6 MeV gamma-rays, plans for laboratory testing were reviewed and plans for field tests were developed. The project had its principal focus on x-ray backscatter imaging, particularly the optimization of the technique, the development of appropriate x ray sources capable of scanning a 3 meter wide search path, and the development of detectors and collimators capable of withstanding the field environment. A unique type of x ray generator was proposed that could meet the scan rate requirements. It consisted of a single 3 m long cylindrical anode with 150 grid controlled cathodes. The technical specification of this tube were developed. A laboratory demonstration of the feasibility of this concept was carried out by an associate contractor.*

**ACCESSION NUMBER: ADA243332**

**\_\_\_\_\_ . Workshop Report: Nuclear Techniques for Mine Detection Research, July 22-25, 1985, Lake Luzerne, New York.** Army Belvoir Research and Development Center, Fort Belvoir, VA. Jul 85. 74p.

*ABSTRACT: The purpose of this workshop was to investigate the use of ionizing radiation techniques for detecting land mines and, in particular, to identify technological advancements that would alter the assessment of the prior workshop held on March 1973. Although emphasis was placed on application of developed or emerging technology to the problem of the detection of buried land mines, detection of concealed explosives in the context of security was also considered. Automatic detection of explosives in luggage and hand-carried items received the greatest attention. Lesser attention was given to detecting explosives concealed within a building's structure. Three particular explosives detection scenarios were considered, and the requirements for each were explicitly discussed by panel members. The first of these, the detection of buried, nonmetallic, anti-vehicular mines, was the area of greatest concern and was given the greatest emphasis by the panel. The other two, detection of anti-personnel mines and detection of explosives in luggage and packages, were considered in less detail.*

**ACCESSION NUMBER: ADA167968**

**Morgan, M.A. Scattering of Radar Waves by Mine Fields.** Final rept. Geo Electromagnetics, Inc., Berkeley, CA.: 1980. 65p.

*ABSTRACT: Radar scattering by an array of surface land mines is studied. The array is considered to be a random perturbation of a uniform array. The analytical evaluation of the expectation is performed for this problem under specified, but realistic, assumptions. The analytic expression for the expectation contains coherent and incoherent array factors, each of which are summations of terms that are weighted by the effect of the antenna pattern. By curve fitting the antenna gain pattern with exponential functions in elevation and azimuth the resultant series are summable. The resultant expression for normalized signal to clutter ratio displays the coherent contributions from the radar system parameters (such as, beamwidths, frequencies, depression angle and pulse width) in conjunction with the randomness of mine placement and the clutter distribution.*

**ACCESSION NUMBER: ADA129693**

**Olness, D.U., and A.S. Warshawsky. Representation of the MON-50 antipersonnel mine for application in SEES.** Lawrence Livermore National Lab., CA.: Aug 92. 6p.

*ABSTRACT: The Security Exercise Evaluation Simulation (SEES) was used to study an ambush of a train carrying soldiers. An integral part of the analysis required that directional, antipersonnel mines (similar to Claymore mines) be included in the scenario. SEES does not have a capability to model the effects of such a weapon explicitly. It was possible, however, to approximate the effect of the mines, albeit crudely, in a way that was judged adequate for the specific study at hand. This report describes that approximation.*

**REPORT NUMBER: UCRLID111813**

**ACCESSION NUMBER: DE93007397XSP**

**Performance Oriented Packaging (POP) Testing and Packaging for Ground Emplaced Mines (i.e. M74, M75 and M79 Mines).** Final rept. Army Armament Research, Development and Engineering Center, Dover, NJ.: 24 Mar 94. 6p.

*ABSTRACT: This Performance Oriented Packaging (POP) report is for the Ground Emplaced Mines (M74, M75, M79 Mines) packed 40 per metal ammunition container IAW drawing 12624514. This report describes results of testing conducted on a similar packaging which is used as an analogy for this item.*

**ACCESSION NUMBER: ADA277845**

**Pijor, T.D. Mine/Countermine Basis of Issue Optimization Plan.** Master's thesis. Naval Postgraduate School, Monterey, CA.: Jun 88. 161p.

*ABSTRACT: The mobility and effective employment of tanks in a future conflict may be seriously threatened by enemy land mines. This thesis presents a high resolution stochastically based simulation to be used in the evaluation of measures of effectiveness to determine the optimal basis of issue of mine/countermine equipment. A discussion of the types of breaching equipment and the tactics involved is used to provide background for the simulation. Several measures of effectiveness are used to determine how the various configurations of breaching equipment affect the battle and battle outcome.*

**ACCESSION NUMBER: ADA200117**

**Printz, J. Pursuit Deterrent Munition Reserve-Cell Ammonia Battery Redesign Analysis.** Final rept. 1986-1990. Army Armament Research and Development Center, Dover, NJ. Fire Support Armament Center.: Apr 91. 42p.

*ABSTRACT: The M86 pursuit deterrent munition (PDM) went into full-scale production in early 1989. At this time a serious design flaw was discovered in the electronics system of the mine. the reserve ammonia battery in the system had a serious performance problem at cold temperatures. This performance problem had not been apparent on the M692/M731 area denial artillery munition (ADAM), a ballistically-launched antipersonnel land mine that was later adapted for hand-emplacement (and subsequently evolved into PDM). A thorough engineering analysis, involving a Taguchi design of experiments, was necessary to determine how the battery could be improved to solve the performance problems encountered. This report discusses this engineering analysis, in detail, from the development of the PDM until the incorporation of the corrective fix for the system.*

**ACCESSION NUMBER: ADA234943**

\_\_\_\_\_. **RAAM Integrated Circuit Source Change Analysis.** Final rept. 1989-1990. Army Armament Research and Development Center, Dover, NJ. Fire Support Armament Center.: Sep 90. 38p.

*ABSTRACT: This report prepared to provide an analysis of the change from gold eutectic die attach integrated circuits (I.C.) to silver-glass die attach I.C. for the M718/M741 remote antiarmor mine (RAAM). An overview of the contract history of the present RAAM electronic lens assembly (ELA) contractor, Accudyne Corporation of Janesville, WI, is presented. An outline of both the gold eutectic die attached process and the silver-glass die attach process is also given. The Government test plan for the die attach change was analyzed and the results and conclusions of the tests listed in the plan are provided.*

**ACCESSION NUMBER: ADA227325**

**Required Operational Capability (ROC) Number LOG 1.59 for a Mine Clearing Plow System.** Marine Corps, Washington, DC.: 1 Apr 83. 12p.

*ABSTRACT: A system, device or combination of devices which can be temporarily mounted to the front of a standard armored tracked vehicle (tank) chassis or other tracked vehicle and controlled by an operator inside the vehicle is required to clear land mines and explosive devices from the path of the vehicle. It should be capable of physically extracting or removing any land mine and/or explosive device which is laying on the surface or buried under up to four inches (10.6cm) of soil cover from the area in front of each track. An Initial Operational Capability of 1985 is desired.*

**ACCESSION NUMBER: ADA1274752/ADA129447**

**Required Operational Capability (ROC) Number LOG 1.63 for the Trailer Mounted Mine Clearing Line Charge (MICLIC) System.** Marine Corps, Washington, DC.: 7 Apr 83. 13p.

*ABSTRACT: The U.S. Marine Corps requires an easily transportable, rapidly deployable mine clearing capability which can be employed without modification or permanent attachment to tactical wheeled and tracked vehicles. A trailer mounted mine clearing line charge would provide a surface-launched capability which could be rapidly employed by mechanized infantry, armored and combat engineer units. A MICLIC system is needed to create a*



vehicle-width cleared lane for tracked and wheeled vehicles through minefield obstacles. The M58A1 Linear Demolition Charge is a standard Marine Corps ordnance item and will satisfy safety and explosive clearing requirements. This line charge will create a breach path approximately 100m long and 10-16m wide against tactically laid, single-impulse pressure mines. The MK 22 rocket used to deploy the M58A1 line charge is in the Marine Corps ordnance inventory. The M353 general purpose, 3 1/2-ton, chassis trailer is an existing asset that can easily be adapted to carry the M58A1 line charge. A launch rail and framework will be required to launch the MK22 rocket and carry the M58A1 line charge pallet on the M353 trailer chassis. The adaptation of existing ordnance and trailer assets will satisfy many of the basic requirements.

**ACCESSION NUMBER: ADA129426**

**Required Operational Capability, USMC-ROC-213.3.5 for Amphibious Continuous Breach Land Mine Countermeasure System.** Marine Corps, Washington, DC.: 20 May 87. 23p.

*ABSTRACT: The Marine Corps has a requirement for a mobile mine countermeasure system (hereafter referred to as the system) capable of breaching enemy minefields in very shallow water and from the high watermark inland in conjunction with lead echelons of the amphibious assault. The system will be employed by assault amphibious vehicle (AAV) units to provide a highly mobile, quick response capability for the assault breaching of single impulse pressure and tilt-rod antitank and antipersonnel minefield. A preplanned product improvement (P3I) goal will be the neutralization of magnetically fuzed, blast hardened and multiple impulse mines. The initial operational capability (IOC) for the system is FY91. The date for full operational capability (FOC) is scheduled for FY94.*

**ACCESSION NUMBER: ADA183962**

Riggs, Lloyd S., and Charles A. Amazeen. **Measurements in Moist and Wet Soils with the Waveguide Beyond Cutoff or Separated Aperture Dielectric Anomaly Detection Technique.** Final rept. Army Belvoir Research Development and Engineering Center, Fort Belvoir, VA.: Jun 91. 38p.

*ABSTRACT: This report present experimental results concerning the separated aperture (or waveguide beyond cutoff) buried mine detection scheme. More specifically, the experimental data presented describes the ability of the separated aperture sensor to detect buried dielectric anomalies under moist or saturated (wet) soil conditions. This data was collected during June - August 1990 at the Fort Belvoir Experimental Mine Lanes Facility, Fort Belvoir, Va. This report is part of ongoing research to build an engineering database to be used in a long-term research program directed toward the development of a complete understanding of the fundamental electromagnetic principles underlying the separated aperture mine detection technique and to assess the general feasibility of separated aperture mine detectors. The moist and wet soil experiments described in this report should be viewed as a continuation of earlier experimental efforts described in BRDEC Technical Report No. 2497, August 1990, (AD-A227008).*

**ACCESSION NUMBER: ADA239409**

\_\_\_\_\_. **Research with the Waveguide Beyond Cutoff or Separated Aperture Anomaly Detection Scheme.** Fort Belvoir, VA.: Army Belvoir Research Development and Engineering Center, Aug. 1990. 67 pgs.

*ABSTRACT: This report presents experimental results concerning the separated aperture (or waveguide beyond cutoff) buried mine detection scheme. The primary purpose of this research effort is to contribute to an engineering database to be used in a long term research program directed toward the development of a complete understanding of the fundamental electromagnetic principles underlying the separated aperture mine detection technique and to assess the general feasibility of separated aperture mine detectors.*

**ACCESSION NUMBER: ADA227008**

Romstedt, G.N. **CSS/EMW/SOF (Combat Service Support/Engineering and Mine Warfare/Special Operations Forces) Mission Area Materiel Plan (MAMP) Software.** Final rept. Feb-Sep 86. McLean Research Center, Inc., VA.: Sep 86. 343p.

*ABSTRACT: This report documents the status of the Combat Service Support (Database Management Systems)/Engineering and Mine Warfare (EMW)/Special Operations Forces (SOF) Mission Area Material Plan (MAMP) Software. This software is used for program planning and resource allocation AMC RDT&E initiatives. It also presents an analysis of some of the system aspects of the automated MAMP as it is instituted throughout AMC, and of the program prioritization methods used.*

**ACCESSION NUMBER: ADA172652**

Sabol, B., and T. Berry. **Effects of Microtopographic Features on Tilt of the Wide Area Mine Ground Platform.** Final rept. Army Engineer Waterways Experiment Station, Vicksburg, MS. Environmental Lab.: May 91. 25p.

*ABSTRACT: Under the Proof of Principle Program for development of the Wide Area Mine (WAM), the US Army Engineer Waterways Experiment Station was responsible for characterizing terrain features expected to affect the WAM performance. The off-vertical angle of the WAM ground platform (tilt) erected on the terrain surface will affect several critical functions of candidate WAM systems. Digital terrain elevation data of adequate spatial resolution (2-ft horizontal spacing) was not available to accurately estimate the distribution of tilt angles for the WAM ground platforms. Actual tilt measurements were therefore made on pre-erected (legs locked in pulse) WAM surrogates (mass models) on four terrain surface types representing managed and agricultural lands. Mean tilt angles ranged from 2 deg for meadowland to almost 11 deg for a freshly plowed and rowed field. The Textron Defense System WAM exhibited a slightly larger mean and standard deviation of tilt angle than the Honeywell, Inc., WAM for each terrain surface type; however, this difference was statistically significant in only one of the four cases. Because this study did not consider the ground platform erection process, these data should not be interpreted as tilt angles resulting from realistic deployment of WAMs.*

**ACCESSION NUMBER: ADA237421**

Sabol, B.M.; et al. **Environmental Site Characterization for the Wide Area Mine Sensor Demonstration, Aberdeen Proving Ground, October 1988.** Final rept. Army Engineer Waterways Experiment Station, Vicksburg, MS. Environmental Lab.: May 91. 43p.

*ABSTRACT: Under the proof-of-principle program for the development of a wide area mine (WAM), the US Army Engineer Waterways Experiment Station was responsible for characterization of the temperature environment in which WAM developmental tests would be conducted. The principal temperate area for WAM testing was designated to be the US Army Aberdeen Proving Ground, Maryland. This report presents data that characterize terrain and environmental factors expected to affect WAM sensor performance. Field measurements were made before and during the conduct of WAM captive flight tests and ground sensor data acquisition exercises. Measurements included soil and seismic tests, a quantitative vegetation survey, thermal terrain characterization measurements, and the collection of onsite meteorological data.*

**ACCESSION NUMBER: ADA237045**

Sanz, G.M. **Countermine Combat Systems Analysis (Mine Plow Evaluation Module).** Technical rept. Feb-Sep 85. BDM Corp., Vienna, VA.: 15 Sep 85. 70p.

*ABSTRACT: This report summarizes the results of tasks conducted to provide the Engineer Support Laboratory with a low cost evaluation model to be used in the assessment of countermine concept alternatives. The model is microcomputer-based and supported by a commercial software package which provides ease of use, rapid computational abilities, and useful graphics features.*

**ACCESSION NUMBER: ADA159444**

Sargis, P.D. **Buried mine detection using ground-penetrating impulse radar.** Lawrence Livermore National Lab., CA.: Mar 95. 13p. [Symposium on autonomous vehicles in mine countermeasures, Monterey, CA (United States), 3-7 Apr 1995.]

*ABSTRACT: LLNL is developing a side-looking, ground-penetrating impulse radar system that can eventually be mounted on a robotic vehicle or an airborne platform to locate buried land mines. The system is described and results from field experiments are presented.*

**REPORT NUMBER: UCRLJC119069, CONF95041541**

**ACCESSION NUMBER: DE9501144**

Schwartz, Richard E. and Dennis F. DeRiggi. **SIMNET-Based Tests of Antihelicopter Mines.** Final Report. Alexandria, VA: Institute for Defense Analyses, Jan 94. 58p.

*Abstract: This report describes a series of SIMNET Semi-automated forced armor engagements in which antihelicopter mines are deployed. The impact of two types of antihelicopter mines on armor exchange ratios and other combat measures is presented. Learning effects are analyzed for both types of mines. Antihelicopter mines can have a significant effect on small unit engagements when used in conjunction with an effective air defense system. Direct fire and sublet launched antihelicopter mines, when properly deployed are capable of depriving attack helicopters safe ingress routes and firing positions.*

**ACCESSION NUMBER ADA281162**

Schwartz, Richard E.; et al. **The Smart Mine Simulator User's Guide and Algorithm Description.** Final Rept. Institute for Defense Analyses, Alexandria, VA. 1 Dec 93. 74p.

*ABSTRACT: The Smart Mine Simulator (SMS) is a computer simulation that runs on two UNIX workstations and operates in the SIMNET/BDS-D distributed simulation environment. It simulates smart antiarmor mines, two variations of smart antihelicopter mines, and conventional antiarmor mines, enabling these mines to participate in SIMNET exercises for analytic, training, demonstration, or other purposes. This document describes the SMS structure, its algorithms for simulating mines, and how to install and use it. The document is intended to support both the planning of distributed simulation exercises and the installation and operation of the SMS on simulation networks.*

**ACCESSION NUMBER: ADA277803**

**Semi-Annual Performance Report on Physics of Buried Mine Detection and Classification.** Technical Letter Report, 1 Mar-31 Aug 94. Austin, TX: Texas University at Austin Applied Research Labs, Jan 95. 8p.

*Abstract: A better understanding of the science and engineering of buried mine detection in (1) offshore and (2) surf zone sediments, leading to safe, standoff detection technologies. This project is part of a leveraged investment program for ONR and APPA offices, which involves SPECWAR and USMC interests, to pursue major research thrusts already begun by the authors, that will lead the way to systems development. The work is further leveraged by the cooperation of the SACLANT Undersea Research Center (SACLANTCEN) which will provide cooperating seafloor scientists, research tools and research vessels in a joint effort to research the basic physics of the governing processes.*

**ACCESSION NUMBER ADA289786**

Shoenfelt, N.M. **Selectable Lightweight Attack Munition Operating Component of the Gate Array.** Technical rept. Army Armament Research and Development Center, Dover, NJ. Fire Support Armament Center.: Apr 91. 26p.

*ABSTRACT: The selectable lightweight attack munition (SLAM) is a small explosive armament. It can be used similarly to a mine where it can be placed on the ground to detonate when the magnetic signature of the desired*

target is detected. It can also be used with a tripline or to detonate after a set period of time. The operation of the SLAM is controlled by electronics with the majority of functions on a gate array. The functions of the gate array that control the operation of the SLAM are described in this report.

**ACCESSION NUMBER: ADA233926**

**Simard, Jean-Robert. Experimental Evaluation of the Apparent Temperature Contrast Created by Buried Mines as Seen by an IR Imager.** Defence Research Establishment Suffield, Ralston (Alberta).: Nov 94. 35p.

*ABSTRACT: The detection of buried mines is a problem of prime interest internationally. One potential method to succeed in this task is to use passive IR imaging to form thermal images of the soil surface. Even though this technique has been intensively investigated for the last 15 years, only few publicly reported studies show quantitative measures of the apparent temperature contrast at the soil surface above buried mines. This document aims to improve this situation. Apparent temperature contrasts are measured for different mine-soil combinations over 24 hour periods with a camera sensitive to long wave infrared (8-12 micrometer). The effect of the variation of burial depth is investigated and special attention is taken to differentiate the thermal effects associated with the soil disturbance from the mine itself. A maximum average of 2 degrees C in apparent thermal contrast disappears when the burial depth exceeds 8 cm for the case where the thermal disturbance is related to the buried mine only. A 50% increase (-3 degrees C) is observed when the thermal effect of the soil disturbance is present. Furthermore, this last apparent thermal contrast shows little dependency with the burial depth. These results are promising for the detection of mines buried in compacted soil. However, serious reservations about an acceptable false alarm rate and the duration of the thermal effect created by the soil disturbance are expressed.*

**ACCESSION NUMBER: ADA289856**

**INTERNET <http://www.dtic.mil/dtic/review/a289856.pdf>**

**Sinn, J.L. Land Mine Options in Future Crisis and Conflicts.** Student essay. Army War Coll., Carlisle Barracks, PA.: 9 Mar 87. 33p.

*ABSTRACT: Newly developed land mine barrier and obstacle systems play a significant role in AIRLAND battle tactical concepts. However, little has been written regarding the use of these systems at the operational and strategic levels of war. This paper examines the potential impact of land mine systems on the range of military, political, and socio-psychological options available to American decision-makers in future crisis and conflicts. It deliberately avoids questions concerning system cost, the number and mix of systems to procure, and the possible limitations involved. Rather, its purpose is to stimulate thinking about ways in which land mine systems may contribute to crisis bargaining, deterrence of conflict, and termination of the same.*

**ACCESSION NUMBER: ADA182782**

**Smith, F.G. History of the Army Ground Forces.** Study Number 17. History of the Third Army. Army Ground Forces, Washington, DC. Historical Section.: 1985. 152p.

*ABSTRACT: The History of the Third Army, 1932-1944, (from organization to combat), was started with the other three field armies on 9 August 1932, by direction by the Army Chief of Staff, General Douglas MacArthur. Third Army was assigned the area formerly administered by the Fourth and Eighth Corps, with its mission coverage the area the Gulf of Mexico and the southern frontier. The Commander had a dual hat as the Corps Area Commander. With the change of command 30 September 1940, the Army HQ was moved from Atlanta to Fort Sam Houston. The Army continued with large scale maneuvers to develop and test doctrine and personnel. Its mission of training and preparation continued until its was alerted and sent overseas for combat deployment. The mission and command was taken over by the Fourth Army.*

**ACCESSION NUMBER: ADA166409**

Stathacopoulos, A.D.; et al. **Combat Illumination Model (COIL). User's Manual.** Final rept. General Research Corp., Santa Barbara, CA.: Sep 75. 164p.

*ABSTRACT: Under ARPA Order No. 2727, General Research Corporation has developed a computer model to represent the illumination in a modern battlefield during extensive ground operations. Called the Combat Illumination model (COIL), it is described in the contract final report in terms of its overall structure and input/output capabilities. Some representative sample results in the visible and IR parts of the spectrum are also presented there. This document is the user's manual for COIL. It supplements the description provided in the final report and provides detailed instructions for its use.*

**ACCESSION NUMBER: ADB008727**

Steinberg, Bernard D and Donald Carlson.. **Research in Ground-to-Air Microwave Imaging.** Philadelphia, PA: Moore School of Electrical Engineering, Mar 95. 29p..

*Abstract: Many potential applications exist for high resolution radar such as direction finding, high accuracy tracing, target counting, and high resolution radar imaging. All of these applications require the use of large, thinned, random or periodic antenna arrays. Many uncertainties exist in such large antenna systems. For example, exact element positions are generally not known because of surveying problems or flexing of the large antenna structure. Adaptive beamforming (ABF) is the solution to the unusual design that achieves these objectives. It deduces the errors in the locations of the receivers that are distributed around the airport or on the air frame and automatically compensates for them in the image processing. This year's work concentrated on three tasks. The first was to develop a generalized ABF theory for the class of spatial correlation algorithms. The second was to extend the resolution of a microwave leading radar to 15 cm, and the third was to study enhanced target detection sensitivity and target recognition.*

**ACCESSION NUMBER ADA292907 ALSO AVAILABLE ON THE INTERNET**

Sullivan, J.D., and C.N. Kingery. **JUGFAE (Jug-Contained Fuel-Air Explosive) Concept.** Final rept. Army Ballistic Research Lab., Aberdeen Proving Ground, MD.: Apr 88. 51p.

*ABSTRACT: Uncontested minefields, ones without covering enemy fire, are cleared cautiously but still cause casualties. The Jug-Contained Fuel-Air-Explosive (JUGFAE) concept does not send men into the minefield, but lets them proceed methodically from the minefield boundary. Safety and thoroughness are inherent in the setup process. The concept prescribes crane emplaced rows of plastic jugs containing detonable fuel. When fueled jugs are in place, a single large fuel-air explosion is triggered. The explosion will neutralize susceptible land mines. The 'don't cross' repeats line is moved across the neutralized area and the setup operation is repeated. The cycle repeats until the mined area is cleared. The errors in placing jugs and overlapping fuel-air clouds can be reduced so that a long line of clouds explodes. Based on 55 liters of fuel per jug, the needs are 92 jugs per km of front and a cost of about \$1 per square meter. In very large minefields, jug numbers and costs are daunting. Increased cloud radius (6.2m presently) significantly reduces the needs.*

**ACCESSION NUMBER: ADA195794**

**System/Design Trade Study Report for the Navigation of the Airborne, Ground Vehicular and Man-Portable Platforms and Support of the Buried Ordnance Detection, Identification, and Remediation Technology.** Indian Head, MD: PRC, Inc., Mar 95. 79p.

*Abstract: This document contains a System Design Trade Study on the optimum navigation systems for airborne, ground-vehicle and man-portable Unexploded Ordnance detection platforms. This study will be used by Unexploded Ordnance Advanced Technology Demonstration decision-makers to make informed technical and programmatic decisions concerning the use of new navigation and location technologies in the detection, identification and remediation of Unexploded Ordnance.*

**ACCESSION NUMBER ADA295740**

**INTERNET <http://www.dtic.mil/dtic/review/a295760.pdf>**

Turbiville, G.H. **Soviet Troop Reductions in Europe: The Changing Face of Engineer Force Structure and Operations.** Final rept. Army Combined Arms Center, Fort Leavenworth, KS. Soviet Army Studies Office.: Apr 89. 8p. [Pub. in *The Military Engineer*, p10-14 Mar-Apr 89.]

*ABSTRACT: Communist Party General Secretary Mikhail S. Gorbachev's December 7, 1988 announcement of unilateral Soviet troop reductions gave Western defense specialists new factors to consider in the NATO/Warsaw Pact balance. It also highlighted what military planners had long known: that the implications of any troop cuts depend as much on the status of specialized units and combat support formations as they do on tanks, artillery, aircraft, and other traditional combat power measures. Central to Gorbachev's announcement was to promise to reduce certain types of landing and engineer assault units, together with ground maneuver units and weapons systems. These reductions, and a concurrent restructuring of other Soviet forces in Eastern Europe, will result in what Gorbachev asserted will be a defensive posture. While the stated Soviet cuts and changes have many dimensions, the important implications for Soviet engineer force structure and operations are particularly intriguing and little studied. These implications must be considered in the context of Soviet perceptions and military developments, and in the recognition that there are many uncertainties in what is to come.*

**ACCESSION NUMBER: ADA216487**

U.S. General Accounting Office. **Mission Area Analyses Conducted by the Army Training and Doctrine Command.** General Accounting Office, Washington, DC. Mission Analysis and Systems and Acquisition Div.: 7 Apr 83. 4p.

*ABSTRACT: TRADOC's mission area analysis program was established in response to Army Regulation 1000-1 which requires that mission needs be based on an analysis of Army missions. For purposes of the TRADOC mission area analysis program, the Army's combat tasks were divided into the following 12 mission areas: Close Combat (Light); Close Combat (Heavy); Fire Support; Air Defense; Combat Service Support; Aviation; Nuclear Defense, Bacteriological or Chemical Environment, and offensive Chemical Warfare; Battlefield Nuclear Warfare; Engineering and Mine Warfare; Intelligence and Electronic Warfare; Communications; and Command and Control.*

**REPORT NUMBER: GAO/MASAD-83-20**

**ACCESSION NUMBER: ADA126610**

\_\_\_\_\_. **Unexploded Ordnance: A Coordinated Approach to Detection and Clearance is Needed.** General Accounting Office, Washington, DC. National Security and International Affairs Div.: Sep 95. 30p.

*ABSTRACT: Over the past 2 years, several accounts of the casualties caused by antipersonnel landmines have brought to light the threat such munitions pose years after hostilities cease. The deaths and injuries attributed to these mines each year have been estimated to total about 30,000. Many of the victims are civilians, including children. While the contamination of land caused by landmines and other forms of unexploded ordnance (UXO) may appear to be primarily a Third World issue, closer examination suggests that the problem is shared by developed nations as well. As you requested, we assessed the extent to which ongoing or foreseeable technology efforts offer solutions to worldwide landmine and other UXO problems.*

**REPORT NUMBER: GAO/NSIAD-95-197**

**ACCESSION NUMBER: ADA300773**

Von Tresckow, Arnold. **Land Mines (Landminen).** Trans. of Soldat und Technik (West Germany) no. 8 1975. Washington, D.C.: Naval Intelligence Support Center, Translation Div, Feb 1978. 43p.

*ABSTRACT: Long before World War I, the term 'Mine Warfare' was well known. The term was used to denote tunnels, advanced towards enemy positions and usually filled with large amounts of explosives which, when*

*initiated, were to bury enemy positions or destroy them, in order to make possible the breakthrough of friendly forces. Also covered by this term was combat against ships with naval mines. While this article is entitled 'landmines', its discussion is limited to antitank mines and mines used against other ground vehicles, as well as mines used against live targets on the ground. Both types of mines had their origin as a result of the conditions prevailing during World War I. (Author)*

**ACCESSION NUMBER ADA053305**

Walczak, J., and K.J. Bathe. **Nonlinear Analysis of a TM-46 Soviet Land Mine.** Final rept. 25 Mar 86-Mar 88. Adina Engineering, Inc., Watertown, MA.: 29 Mar 88. 55p.

*ABSTRACT: A static and dynamic analysis of a TM-46 land mine is presented. The objective of this study was to establish a finite element analysis of the mine including an accurate modeling of the contact conditions. The report presents the finite element modeling and solution results for the static buckling response and the dynamic response under blast pressure loading.*

**ACCESSION NUMBER: ADA206986**

Wissler, J.E. **Anti-Mechanized Defense: A Computerized Simulation for Squad Leader Training.** Master's thesis. Air Force Inst. of Tech., Wright-Patterson AFB, OH. School of Systems and Logistics.: Sep 83. 359p.

*ABSTRACT: Marine Corps doctrine requires deployment of one combat engineer platoon with each BLT. Engineer squad leaders provide anti-mechanized defense expertise to Battalion Landing Team rifle company commanders. This expertise includes the effective use of barriers and obstacles in conjunction with organic direct fire antimech weapons and combined arms support. Current squad leader training in these areas is limited due to budget, equipment, and training area constraints during both shipboard and ashore periods. Gaming has proven a satisfactory approach in supplying this training. This research developed a two-player, Pascal-based, computerized simulation incorporating USMC and Soviet direct and indirect fire weapons, standard barriers and obstacles, and appropriate Soviet tactics. Development of the game included initial verification and validation testing through comparison of game responses to MCCRES standards and interpretation of actual Marine enlisted playtesting. The completed prototype war game was shown to provide realistic and enjoyable training on the squad leader level.*

**ACCESSION NUMBER: ADA134962**

Wuest, C.R. **Energetic charged particle beams for disablement of mines.** Lawrence Livermore National Lab., CA.: 27 Mar 95. 11p. Autonomous vehicles in mine countermeasures symposium, Monterey, CA (United States), 5 May 1995.]

*ABSTRACT: LLNL has an ongoing program of weapons disablement using energetic charged particle beams; this program combines theoretical and experimental expertise in accelerators, high-energy and nuclear physics, plasma physics and hydrodynamics to simulate/measure effects of electron and proton beams on weapons. This paper reviews work by LLNL, LANL and NSWC on detonating sensitive and insensitive high explosives and land mines using high-current electron beams. Computer simulations are given. 20--160 MeV electron beams incident on wet/dry soils are being studied, along with electron beam propagation in air. Compact high current, high energy accelerators are being developed for mine clearing. Countermining missions of interest are discussed. 25 refs., 9 figs.*

**REPORT NUMBER: UCRLJC120594, CONF95051972**

**ACCESSION NUMBER: DE95009669**

## **INTERNET SITES**

### **Ban Land Mines Project**

Physicians for Global Survival, Canada.

URL: <http://www.web.apc.org/~pgs/pages/ldmn0.html>  
for their Landmine Links and WWWs

URL: <http://www.web.apc.org/~pgs/pages/ldwwlst.html>

### **Berserkistan Travel Advisories**

URL: <http://www.linder.com/berserk/mines.html>

Landmine Awareness and Survival Techniques – adapted from the manuals of the Mine Clearance Training Unit (UNTAC) UN Forces, Cambodia. Includes descriptions as well as links to other sites

### **The Brutal Reality of Land Mines... A Mechanical Means of Land Mine Detection.**

URL: <http://faramir.mece.ualberta.ca/landmine.html>

### **Canada and the Global Land Mine Crisis**

URL: <http://www.dfait-maeci.gc.ca/english/foreignp/disarm/mines.htm>  
Canada's approach to the land mine crisis.

### **Canadian Disarmament Digest**

URL: <http://www.dfait-maeci.gc.ca/english/foreignp/disarm/cddhome1.htm>

The CANADIAN DISARMAMENT DIGEST provides a summary of developments concerning non-proliferation, arms control and disarmament issues from a Canadian perspective. It is produced by the Non-proliferation, Arms Control and Disarmament Division of the Canadian Department of Foreign Affairs and International Trade.

### **CIDC: Land Mines**

URL: <http://eagle.uccb.ns.ca/demine/index.html>  
Canadian International Demining Centre homepage.



## **Demining Research at University of Western Australia**

**URL:** <http://mech.uwa.edu.au/jpt/demining.html>

A copy of their working paper on Robotic Landmine Clearance as well as links to other landmine sites is available.

## **DeTeC HOMEPAGE - The Demining Technology Center at the EPFL**

(Ecole Polytechnique Federale de Lausanne – Swiss Federal Institute of Technology)

**URL:** <http://diwww.epfl.ch/lami/detec/>

Provides a lot of good links

## **Hidden Killers 1994: The Global Landmine Crisis (U.S. State Dept)**

**URL:** <gopher://dosfan.lib.uic.edu:70/0F-1%3A7332%3A1994%20Land%Mines%20Report>

or go to the Department of State's GOPHER and to do a search

**URL:** <gopher://dosfan.lib.uic.edu:70/7A:Gopher:2:7>

## **Human Rights and Landmines**

**URL:** <http://www.maui.com/~lesslie/landmines.html>

## **Humanitarian Demining**

Sponsored by the U.S. Army communications Electronics Command, Night Vision and Electronic Sensors Directorate, Countermining Division

**URL:** <http://www.demining.brtrc.com/>

This site provides some great links including to a world map showing mine infestation areas, other links and most usefully, a mine identification guide database which identifies mines based on their characteristics. Pictures are included.

## **International Federation of Medical Students' Association Standing Committee on Refugees and Peace (IFMSA-SCORP)**

**URL:** <http://crick.fmed.uniba.sk/ifmsa/scorp/org.html>

This site entitled "Organizations Working to Ban Landmines" provides names and addresses of over 427 organizations and 33 countries working to ban landmines.

## **ICRC: International Red Committee of the Red Cross**

**URL:** <http://www.icrc.ch/icrcnews/2276.html>

This location contains basic facts and information about landmines, a bibliography, press releases and news items on antipersonnel weapons.

## **JAYCOR: Standoff Mine Detection Radar System**

**URL:** <http://www.jaycor.com/Mine/Mine.html>

Describes the JAYCOR standoff mine detection system. It can detect and identify both surface and buried mines.

## **Land Mine Warfare: Detection and Clearance**

The DTIC Review, vol 2, no. 1 (entire issue) and includes a list of electronic references.

**URL:** <http://www.dtic.mil/dtic/review/review2.html#papers>

## **Land Mines**

**URL:** <http://www.cfcsc.dnd.ca/links/peace/mines.html>

Links under Peace and disarmament, from the Information Resource Centre, Canadian Forces College, Department of Defence (Canada)

## **Landmines Special Report Top Page**

**URL:** <http://www.oneworld.org/landmines/index.html>

ONEWORLD ONLINE and its partners give the facts about landmines, examine the arguments for banning them, report on the UN review conferences

## **Links to Conventional Arms Trade and Other Relevant Sites**

Center for Defense Information

**URL:** <http://www.cdi.org/atdb/atdblink.html>

Arms Transfer Working Group (ATWG), from the Arms Trade Database. This site includes links to many other land mine sites.

## **Links to Landmine sites, Warchild Landmine Project**

**URL:** <http://www.warchild.org/news/links.html>

This provides a number of good links

## **Mennonite Central Committee Peace Program**

**URL:** <http://www.mennonitecc.ca/mcc/programs/peace/land-mines.html>

News and links

## **MineFacts**

**URL:** <http://204.7.227.67/infonet/minecd.html>

An interactive database program developed by the U.S. Department of Defense. It contains information and graphics on over 675 landmines from around the world.

## **MINERATS: Anti-personnel Mine Clearance Robots**

**URL:** <http://fourmilab.ch/documents/minerats>

Common anti-personnel mines (with pictures)

**URL:** <http://fourmilab.ch/documents/minerats/figures/mines.html>

## **Minrapport**

**URL:** <http://www.rb.se/kampanj/mine1.html>

Sweden's Landmine Defence (full text document)

## **MINWARA – The Mine Warfare Association**

**URL:** <http://www.minwara.org/>

## **North Atlantic Assembly (of the North Atlantic Treaty Organization)**

**URL:** <http://superior.carleton.ca/~dcohn/NAA/>

Index of documents including Landmines.

## **Norwegian People's Aid - The Menace of Mines**

**URL:** <http://www.fna.no/nofo/info/mine.html>

Norwegian People's Aid - International de-mining activities. The Menace of Mines. Obstacle and Challenge in Development. Map of solidarity and mine-clearing activity.

## **Pacific Talk Virtual Library Index**

**URL:** <http://www.pactok.net.au:80/docs/>

Provides documents on/by the Cooperation Committee for Cambodia (CCC), the Documentation Center for Cambodia (DCCAM), and LANDMINES, under the Convention on Conventional Weapons (CCW)

## **Stiftung Menschen gegen Minen**

The Humanitarian Foundation of People against Landmines homepage (in English).

**URL:** <http://www.dsk.de/mgm/indexe.htm>

Includes 100 best links to humanitarian demining.

## **UNICEF**

**URL:** <http://www.unicef.org/sowc96pk/mines.htm>

## **The United Nations Demining Database**

**URL:** <http://www.un.org/Depts/Landmine/>

Includes demining programme reports, country and area reports and casualties and incidents as well as links to other Landmine sites.

## **United Nations International Meeting on Mine Clearance**

**URL:** <http://www.fourmilab.ch/documents/minerats/GenevaUNReport.html>

Report on the United Nations International Meeting on Mine Clearance. Geneva, July 5-7, 1995.

## **U.S. Announces Anti-Personnel Land Mine Policy**

THE WHITE HOUSE Office of the Press Secretary: For Immediate Release May 16, 1996.

**URL:** <http://docs.whitehouse.gov/white-house-publications/1996/05/1996-05-16-fact-sheet-on-us-anti-personnel-landmine-policy.text>

## **U.S. Army's Mines, Countermines and Demolitions' Web site**

**URL:** <http://www.pica.army.mil/orgs/pm-mcd/>

## **Vietnam Veterans of America Foundation**

**URL:** *<http://www.vvaf.org/landmine/weblinks5.htm>*

Established by a dedicated group of Vietnam Veterans in 1980, VVAF has transformed the experience of war suffered by America's Vietnam veterans into a program of service to others who have suffered the scourge of national and international conflict. Links to International and U.S. Campaigns to Ban Landmines.

## **World Health Organization Land Mine Report**

**URL:** *<http://www.web.apc.org/~pgs/pages/lmnwho.html>*

Direct and Indirect Consequences of Landmines on Public Health by Faiz Kakar, Ph.D, Consultant, Division of Emergency and Humanitarian Action, WHO, July 1995.

## **GOOD SITES FOR SEARCHING**

(should be used along with the standard web searchers)

### **CALL - Center for Army Lessons Learned database**

**URL:** *<http://call.army.mil:1100/cgi-bin/webinator>*

This searches the following sites: CALL, Warfighter XXI, JVCAAT, FMSSO, Military Review, Soldiers Magazine Online, Ft Leonard Wood, Armor Magazine and Ft Knox web sites.

### **DTIC's STINET**

**URL:** *<http://www.dtic.mil/stinet/public-stinet/all/>*

DTIC's Scientific and Technical Reports Collection. This allows you to search simultaneously the following sites: DoD Index of Specifications and Standards; DOE OPENNET Database; DOE Reports Bibliographic Database; DTIC U2 Technical Report Database; DoD Directives; DoD Instructions; NASA Technical Reports Database; NASA Open Literature Database; NASA NACA Technical Reports Database and NASA Goddard Technical Reports Database.

### **GovBot Database of Government Web sites**

**URL:** *<http://pardoo.cs.umass.edu/GovBot/>*

GovBot has gathered over 125,000 web pages from U.S. Government and Military sites around the country.

# Appendix A-3

## Bibliography on Mine Warfare by Richard Hansen, NMA Historian

- Abbot, Henry L. - **BEGINNINGS OF MODERN SUBMARINE WARFARE** Under Captain Lieutenant David Bushnell - A facsimile reproduction of the rare 1881 pamphlet with Biographical Appendices and Bibliography by Frank Anderson. ARCHON BOOKS, Hamden, Connecticut, 1966.
- Abbot, Henry L., Lt. Col. Corps of Engineers, U.S. Army - **A REPORT upon SYSTEM OF SUBMARINE MINES for defending the HARBORS OF THE UNITED STATES** - Government Printing Office - Washington - 1881
- THE AMERICAN ORDNANCE ASSOCIATION - NOTES ON NAVAL ORDNANCE of the AMERICAN CIVIL WAR 1861-1865** - Washington, D.C. - 1960
- Abbot, Willis J. - **THE NAVAL HISTORY OF THE UNITED STATES, Vol 1** Peter Fenelon Collier - Dodd, Mead and Company - 1898
- Allen, Peter - **ONE MORE RIVER, The Rhine Crossings of 1945** - Charles Scribner's Sons - New York - 1980
- Bailey, Dan E. - **WORLD WAR II WRECKS OF PALOU** - 1991 - North Valley Diver Publications - Redding, CA
- Bailey, Dan E. - **WORLD WAR II WRECKS OF THE KWAALEIN AND TRUK LAGOONS** - second revised edition - North Valley Diver Publications - Redding, CA
- Baker, Mark - **NAM, The Vietnam War in the Words of the Men and Women Who Fought There** - William Morrow and Company, Inc - New York - 1981
- Belknap, Reginald R., Captain, USN - **THE YANKEE MINING SQUADRON, or, LAYING THE NORTH SEA MINE BARRAGE** - Naval Institute - Annapolis, Maryland - 1920
- Belte, James & William - **TYPHOON OF STEEL, The Battle for Okinawa** - Harper & Row - New York, Evanston, and London - 1970
- Blair, Clay, Jr. - **SILENT VICTORY, The U.S. Submarine War Against Japan** - J.B. Lippincott Company - Philadelphia and New York - 1975
- BLUE JACKETS' MANUAL** - Naval Institute Press - 1968
- Bogart, Charles H. **CONTROLLED MINES, A History of their use by the United States** - Weapons and Warfare Press - 1985
- Boggs, H. Glenn, Lt(jg), USN - **A STUDY OF THE CONFEDERATE NAVAL MINING CAPABILITY IN THE U. S. CIVIL WAR** - 11 May, 1970 - Naval Schools, Mine Warfare, Naval Base, Charleston, South Carolina
- Breuer, William B. - **OPERATION DRAGOON, The Allied Invasion of the South of France** - Presideo Press - Novato - 1987
- Brodie, Bernard - **A GUIDE TO NAVAL STRATEGY** - Princeton University Press - Princeton, 1944.
- Bureau of Naval Personnel - Training Manual - **THE EVOLUTION OF NAVAL WEAPONS** - August, 1947
- Bucknill, James Townsend - **SUBMARINE MINES and TORPEDOES as APPLIED TO HARBOUR DEFENCE** - John Wiley & Sons - London - 1889
- Cagle, Malcomb W., Commander, USN & Manson, Frank A., Commander, USN - **The SEA WAR IN KOREA** - Naval Institute Press - Annapolis, MD - 1957
- Cambell, John - **NAVAL WEAPONS OF WORLD WAR TWO** - Naval Institute Press - 1985
- Chant, Christopher - **THE ENCYCLOPEDIA OF CODE NAMES OF WORLD WAR II** - Routledge & Kegan Paul, London, England 1986
- Chief of Naval Operations - **MINE WARFARE IN THE NAVAL ESTABLISHMENT** - no date - no publisher - 1946

Cleator, P.E. - **WEAPONS OF WAR** - Thomas Y. Crowell Company - New York - 1967

Coleta, Paolo E. - **A BIBLIOGRAPHY OF AMERICAN NAVAL HISTORY** - Naval Institute Press - 1981

Cowie, J.S., Captain, Royal Navy - **MINES, MINELAYERS, AND MINELAYING** - Oxford University Press - London, New York, Toronto - 1949

Crowther, J.G. & Whiddington, R. - **SCIENCE AT WAR** - Philosophical Library - New York - 1948

Cutler, Thomas J., LCDR, USN - **BROWN WATER, BLACK BERETS, Coastal and Riverine Warfare in Vietnam** - Naval Institute Press - Annapolis, MD - 1988

Davis, Noel, Lt. Cmdr., USN - **THE REMOVAL OF THE NORTH SEA MINE BARRAGE** - National Geographic - February, 1920

Dommett, W.E. - **SUBMARINE VESSELS including MINES, TORPEDOES, GUNS, STEERING, PROPELLING, & NAVIGATING APPARATUS.** Whittaker & Co. - London - 1915.

Dorling, Taprell, Captain Royal Navy - **SWEPT CHANNELS, BEING AN ACCOUNT OF THE WORK OF MINESWEEPERS IN THE GREAT WAR (WW I)** - Hodder and Stoughton, Ltd. - London - 3rd edition - 1938

Duncan, Robert G., PhD - **AMERICA'S USE OF SEA MINES** - United States Naval Ordnance Laboratory, White Oak, Silver Springs, Maryland. January, 1962.

Elliott, Peter - **ALLIED MINESWEEPING IN WORLD WAR 2** - Naval Institute Press - Annapolis, MD - 1979

Fahey, James C. - **THE SHIPS and AIRCRAFT of the UNITED STATES FLEET - 1939 (1939) - Two Ocean Fleet Edition (1942) - War Edition (1942) - Victory Edition (1945) - Sixth Edition (1950) - Seventh Edition (1958) - Eighth Edition (1965)**

Fahey, James J. - **PACIFIC WAR DIARY, 1942-1945** - Zebra Books - New York - 1963

Field, James A., Jr. - **HISTORY OF UNITED STATES NAVAL OPERATIONS KOREA** - Government Printing Office, Washington, D.C. 1962.

Foster, Simon - **OKINAWA 1945, Final Assault on the Empire** - Arms and Armour - London - 1994

Friedman, Norman - **U.S. NAVAL WEAPONS - Every GUN, MISSILE, MINE and TORPEDO used by the U.S. Navy from 1883 to the present day** - Conway Maritime Press - 1983

Griffiths, Maurice - **THE HIDDEN MENACE** - Conway Maritime Press - Greenwich, Connecticut - 1981

Hansell, Haywood S, Jr., Major General USAF, Retired - **STRATEGIC AIR WAR AGAINST JAPAN** - Government Printing Office, Washington, D.C. - 1980

Hartmann, Gregory K. **MINE WARFARE HISTORY AND TECHNOLOGY** - Naval Surface Weapons Center - White Oak Laboratory - Silver Springs, Maryland - 1 July, 1975

Hartmann, Gregory K., with Scott C. Truver - **WEAPONS THAT WAIT, Mine Warfare in the U.S. NAVY** - Naval Institute - 1991

Hoyt, Edwin P. - **CLOSING THE CIRCLE, War in the Pacific, 1945** - Avon - 1982

Hutcheon, Wallace S., Jr. - **ROBERT FULTON, Pioneer of Undersea Warfare** - Naval Institute Press - 1981

Hyams, Joe - **FLIGHT OF THE AVENGER, George Bush at War** - Harcourt Brace Jovanovich - San Diego, New York, London - 1991

Johnson, Ellis a. & David A. Katcher - **MINE AGAINST JAPAN** - Naval

Ordnance Laboratory - White Oak - Silver Springs Maryland - June, 1947.

Johnson, Bruce H. Lt(jg), USN - **MINE WARFARE OPERATIONS IN THE RUSSO-JAPANESE WAR (1904-1905)** - Mine Warfare School, Navy Base, Charleston, South Carolina - 25 November, 1968

Joint Army-Navy Assessment Committee - **JAPANESE NAVAL AND MERCHANT SHIPPING LOSSES DURING WORLD WAR II BY ALL CAUSES.** - Government Printing Office - February, 1947

Jones, J. M., Captain, Canadian Navy - **THE VANGUARD HAD TO BE MINECRAFT** - Navy Mine Warfare School - Charleston, SC - November, 1969

Karig, Commander Walter USNR, and Lieutenant Welbourn Kelley, USNR - **BATTLE REPORT, Pearl Harbor to Coral Sea** - Farrar & Rinehart, Inc - New York, Toronto -1944

Keegan, John - **The TIMES Atlas of the SECOND WORLD WAR** - Harper & Row, New York - 1989

King, Arthur D., M.D. - **VIGNETTES OF THE SOUTH PACIFIC, The Lighter Side of World War II** - Privately printed - Cincinnati, Ohio - 1991

Knox, Dudley W. Commodore, USN - **THE HISTORY OF THE UNITED STATES NAVY** - G.P.Putnam's Sons - New York - 1948

Kurzman, Dan - **FATAL VOYAGE, The Sinking of the USS INDIANAPOLIS** Atheneum - New York - 1990

Lenton, H.T. - **AMERICAN GUNBOATS and MINESWEEPERS** - unknown publisher - 1974

Levie, Howard S. - **MINE WARFARE AT SEA** - Martinus Nijhoff Published - Dordrecht/Boston/ London - 1992

Lott, Arnold S. - **BRAVE SHIP - BRAVE MEN** - Naval Institute - 1986

Lott, Arnold S. Lt Cmdr, USN - **MOST DANGEROUS SEA** - Naval Institute Press - 1959

Low, Archibald Montgomery, Professor of Automotive Engineering - **MINE and COUNTERMINE** - Sheridan House, New York - 1940

Lund, Paul, and Harry Ludlam - **OUT SWEEPS, The Story of Mine Sweepers in World War II** - W. Foulsham & Company, LTD. - London, New York, Toronto, Cape Town, Sydney - 1978

Lundeberg, Philip K. - **Colt's SUBMARINE BATTERY - The Secret and the Enigma** - Smithsonian Institute Press - City of Washington - 1974

Maury, Matthew Fontaine - Private papers obtained from the Library of Congress.

McEathron, Ellsworth Dudley, Rear Admiral, USN, Retired - **MINECRAFT IN THE VAN** - unpublished paper he prepared for the United States Navy but it was never published. Books 1 & 2 of 4.

Melia, Tamara Moser - **"DAMN the TORPEDOES", A Short History of U.S. Naval Mine Countermeasures 1777-1991** - Contributions to Naval History #4 - Naval Historical Center - Washington Navy Yard - 1991

Moffat, Alexander W., Captain, USNR (retired) - **A NAVY MAVERICK COMES**



OF AGE, 1939-1945 - Wesleyan University Press - Middletown, CT - 1977.

Morison, Samuel Eliot - HISTORY OF UNITED STATES NAVAL OPERATIONS DURING WORLD WAR II - Little Brown & Company - 1950 to 1962 - 15 volumes.

Morrill, John, Lt. Cmdr., U.S.N. - SOUTH FROM CORREGIDOR - Simon & Schuster - New York - 1943

Naval Analysis Division - THE OFFENSIVE MINE LAYING CAMPAIGN AGAINST JAPAN - Department of the Navy - November, 1946

Naval History Department - ADMINISTRATIVE HISTORY OF MINE CRAFT IN THE PACIFIC FLEET - Mimeographed copy obtained through the Navy History Department - 10 April, 1959

Naval Historical Center - The UNITED STATES NAVY and the VIETNAM CONFLICT - The Setting of the Stage to 1959 - Edwin Bickford Hopper, Dean C. Allard, & Oscar P. Fitzgerald - 1976

Naval Historical Center - The UNITED STATES NAVY and the Vietnam Conflict - Volume II 1959 to 1965 - Edward J. Marolda & Oscar P. Fitzgerald - 1986.

Naval History Division - NAVAL CHRONOLOGY, World War II - Prepared for the Office of the Chief of Naval Operations - Government Printing Office - Washington - 1955

Navy History Division - Guide to UNITED STATES NAVAL ADMINISTRATIVE HISTORIES OF WORLD WAR II - Department of the Navy 1976

Naval History Division, Navy Department - CIVIL WAR NAVAL CHRONOLOGY, 1961-1865 - Washington, D.C. 1971.

Navy Department - DICTIONARY OF AMERICAN FIGHTING SHIPS - Ten Volumes - 1959 to 1981 - Government Printing Office - Washington, D.C.

Navy Department, Bureau of Ordnance - GERMAN UNDERWATER ORDNANCE MINES - 1946

Navy Ordnance Laboratory - CUMULATIVE INDEXES OF PAPERS FROM THE PROCEEDINGS OF MINEFIELD CONFERENCES (I through VX) - Naval Ordnance Laboratory - White Oak, Silver Springs, MD - October, 1972

Nofi, Albert A. - A CIVIL WAR TREASURY - Combined Books - Conshohocken, PA - 1992

Office of the Chief of Engineers - Dale E. Floyd - UNITED STATES COAST DEFENSE, 1775-1950: A BIBLIOGRAPHY - Historical Division - Corps of

Engineers - 1 July, 1984

Ota, Misahide - **This Was The BATTLE of OKINAWA** - Naha Publishing Company - 1981

Patterson, Andrew, Jr. - **A BRIEF HISTORY OF MINE WARFARE** - Mine Advisory Committee, National Academy of Science - Washington, D.C. - 15 January, 1970 - A mimeographed copy

Patterson, Andrew, Jr. & Winters, Robert A. - **A BIBLIOGRAPHY OF THE HISTORY OF NAVAL MINE WARFARE** - Navy Studies Board - January, 1974

Perry, Milton F. - **INFERNAL MACHINES, The Story of Confederate Submarine and Mine Warfare** - Louisiana State University Press - 1965.

Petty, Gilbert "Gib" and June Petty - **A CLEAN SWEEP, A Sailor's Diary, in the Pacific World War II** - Petty Publishing - Kingston, WA

Pfannes, Charles E and Victor A Salamone - **GREAT ADMIRALS of WORLD WAR, Volume 1: The AMERICANS** - Zebra Books, Kensington Publishing Corporation - 1983

Price, Alfred - **The HARDEST DAY, The Battle of Britain, 18 August, 1940** - Charles Scribner Sons - New York - 1980

Rowland, Buford, Lt. Cmdr. USNR & Boyd, William B., Lt. (jg) USNR U.S. **NAVY BUREAU OF ORDNANCE IN WORLD WAR II** Bureau of Ordnance - Government Printing Office - 1948

Sanford, Alfred, Commander, USNR - **FORCE MULBERRY, The Planning and Installation of the Artificial Harbor off U.S. Normandy Beaches in World War II** - William Morrow & Company - New York, 1951

Sheppard, Don - **RIVERINE, A Brown Water Sailor in the Delta, 1967** Originally published by Presideo Press, Novato, CA - Copyright 1992 by Don Sheppard. Issue read published by **POCKET BOOKS, 1994.**

Stafford, Edward Perry, Commander, USN **THE FAR AND THE DEEP** - G.P. Putnam's Sons - New York, 1966

Stirling, Yates, Rear Admiral, USN, Retired - **WHY SEA POWER WILL WIN THE WAR** - Frederick Fell, Inc - New York - 1944

Sullivan, Barry W., Lt(jg), USN - **MINE COUNTERMEASURES IN THE U. S. CIVIL WAR** - Naval Schools, Mine Warfare, Naval Base, Charleston, South Carolina

Tansill, Charles Callan - **BACK DOOR TO WAR, The Roosevelt Foreign**

Policy, 1933-1941 - Henry Regnery Company - Chicago - 1952

Toner, Captain Raymond J., USN - GAMBLE OF THE MARINES - Albert Whitman & Company - Chicago - 1963

Turner, John Frayn - SERVICE MOST SILENT, The Navy's Fight against Enemy Mines - George G. Harrap & Co., Ltd. - London, Toronto, Wellington, Sydney - 1955

Veth, Kenneth F. Retired as Vice Admiral, United States Navy - Oral History department of the Naval Institute - undated

Webb, Edgar D., Commander, Royal Navy - H.M.S. VERNON A Short History from 1930 to 1955 - Published by the WARDROOM MESS COMMITTEE, H.M.S. VERNON - Christmas, 1955

Williams, Frances Leigh - MATTHEW FONTAINE MAURY, Scientist of the Sea - Rutgers University Press - New Brunswick, NJ - 1963

Windas, Cedric W. - TRADITIONS OF THE NAVY - Our Navy Press - Brooklyn, NY - 1942

Winslow, Captain W.G., USN, Retired - THE FLEET THE GODS FORGOT, The U.S. Asiatic Fleet in World War II - Naval Institute Press - Annapolis, MD - 1982

Wolfert, Ira - AMERICAN GUERRILLA in the Philippines - Simon and Schuster - New York - 1945

Ziegler, Janet - WORLD WAR II: BOOKS IN ENGLISH, 1945-65 - Hoover Institution Press - Stanford University - Stanford, CA - 1972

# **Appendix B**

## **Speakers and Attendees at the Symposium on Technology and the Mine Problem**

**November 18-21, 1996  
Naval Postgraduate School  
Monterey, California**



**Technology and the Mine Problem Symposium  
Attendees List**

Dr. Lyles C. Adair  
Coastal Systems Station, DD, NSWC  
Code A21  
6703 W. Highway 98  
Panama City, FL 32407-7001  
USA  
904-234-4260  
436-4260  
904-235-5751  
adair\_lyles@ccmail.ncsc.navy.mil

Russ Adamchak  
Mercury Computer Systems, Inc  
8260 Greensboro Drive #135  
McLean, VA 22039  
USA  
703-761-1156  
703-690-0289  
ADAMCHAK@MC.COM

Ron E. Akers  
Battle Lab U.S. Army Infantry Center  
Commander, USAIC  
Attn: Battle Lab Bld.4 RM343  
Attn: Ron Akers  
Fort Benning, GA 31905  
USA  
706-545-8344 x 835  
706-545-3096  
akersr@benning\_emh2.army.mil

Lex N. Allen  
Tracor Aerospace  
6500 Tracor Lane  
Maildrop 28-47  
Austin, TX 78703  
USA  
512-929-4324  
512-929-2980  
1na@eng1.tracor.com

Dr. Edgar An  
Florida Atlantic University  
Dept. of Ocean Engineering  
Boca Raton, FL 33431  
USA  
561-367-2459  
561-367-3885  
ean@or.fan.edu

Dr. C. John Anderson  
Mining Resource Engineering  
1555 Sydenham Road, R.R. #8  
Kingston, Ontario K7L-4V4  
Canada  
613-545-0466  
613-542-8029

Dr. Jame S. Andrews  
OPNAV  
Navy Pentagon Room 5C715  
Washington, D.C.  
USA  
703-614-5843  
703-697-8368

Matt Arnold  
K 2 T, Inc  
One South Linden Street  
Duquesne, PA 15110  
USA  
412-469-3150 x11  
412-469-8120  
marnold@k2t.com

Captain William G. Arnold  
Airborne Mine Defense  
2531 Jefferson Davis Highway  
Arlington, VA 22242  
USA  
703-602-5095  
703-332-5095  
703-602-5105  
arnold\_william\_g\_capt@hq.navsea.navy.mil

Professor John Arquilla  
NPS  
589 Dyer Road  
Monterey, CA 93943  
USA

**Technology and the Mine Problem Symposium  
Attendees List**

Janet C. Arrowood  
Omnitech Robotics, Inc.  
2640 S. Raritan Cir.  
Englewood, CO 80110  
USA  
303-922-7773  
303-922-7775  
janeta@omnitech.com

ADM Stan Arthur USN (Ret)  
Lockheed Martin Corp.  
1725 Jefferson Davis Hwy, Suite 900  
Arlington, VA 22202-4159  
USA  
703-416-5516

Stephen G. Azevedo  
Lawrence Livermore National Laboratory  
Imaging & Detection Program  
P.O. Box 808, L-437  
Livermore, CA 94551  
USA  
510-422-8538  
510-422-3358  
azevedo3@11n1.gov

Major Ron Baczkowski  
Marine Forces Pacific  
P.O. Box 64117  
Camp H.M. Smith, HI  
96861 USA  
808-477-2752  
808-477-2752  
808-477-3960  
baczkowskir@emhi.mfp.usmc.mil

Ed Bahniuk  
GEC Marconi  
6003 Saddle Horse  
Fairfax, VA 22030  
USA  
703-830-6897  
703-968-0780  
embahn@ibm.net

Dr. Ruzena Bajcsy  
BRASP Laboratory, Rm 301C  
3401 Walnut Street  
Philadelphia, PA 19104-6228  
USA  
215-898-0370  
215-573-2048  
bajcsy@cis.upenn.edu

William N. Baker  
Clausen Power Blade, Inc  
P.O. Box 1326  
McPherson, KS67460  
USA  
316-241-6354  
316-733-2848

Susan L. Bales  
Office of Naval Research  
Ballston Centre Tower Three,  
Rm 143  
800 North Quincy Street  
Arlington, VA 22217-5660  
USA  
703-696-2901  
703-426-2901  
703-696-4162  
bales@onr.navy.mil

Steve F. Ballinger  
Mertz, Inc.  
1018 W. Hartford  
P.O. Box 150  
Ponca City, OK 74602-1443  
USA  
405-762-5646  
405-767-8411  
ballingr@pcok.com

Mrs. Martha C. Barker  
Naval Oceanographic Office  
1002 Balch Blvd.  
Stennis Space Center  
Stennis Space Center, MS  
39522 - 5001  
USA  
601-688-5932  
485-5932  
601-688-5602

**Technology and the Mine Problem Symposium  
Attendees List**

Colonel Dennis C. Barlow  
James Madison University  
College of Integrated Science &  
Technology  
University Blvd.  
Harrisonburg, VA 22807  
USA  
540-568-2760  
540-568-2747  
BARLOWDC@JMU.EDU

COL Leroy Jr. Barnidge  
28th Bomb Wing Commander  
1985 Scott Dr. Suite 1  
Ellsworth Air Force Base, SD  
57706-4710  
USA  
605-385-2801  
675-2801  
605-385-4407

Stephen L. Baron  
Baron and Associates, Inc  
207 Mission St.  
Santa Cruz, CA 95060  
USA  
408-426-4910  
408-429-1071

Professor Don Barr  
U.S. Military Academy  
Dept. of Systems Engineering  
West Point, N.Y. 10996  
USA  
914-938-4374  
914-688-4374  
914-938-5919  
fd4168@exmail.usma.edu

LTCOL Garth J. Barrett  
Mechem International  
4198 Graydon Road  
San Diego, CA 92130  
USA  
619-259-5521

Dr. Carl E. Baum  
PhilliOps Laboratory WSQW  
3550 Aberdeen Ave. SE  
Kirtland AFB, NM 87117-5776  
USA  
246-5092

Alan R. Beam  
ARL/PSU  
P.O. Box 336  
Tracyton, WA 98393  
USA  
360-396-2260  
360-396-4845

MGEN Ronald L. Beckwith USMC  
LeeCor, Inc.  
2001 Jefferson Davis Hwy  
Ste. #1100  
Arlington, VA 22202-3604  
USA  
703-418-1702  
703-418-0034  
rlbeckwith@aol.com

Willard R. Becraft  
General Atomics  
355 G.A. Court  
San Diego, CA 92121  
USA  
619-455-4523

Dr. Joseph Bendahan  
Science Applications International Corp.  
2950 Patrick Henry Drive  
Santa Clara, CA 95054  
USA  
408-727-0607

John R. Benedict  
Johns Hopkins University  
Applied Physics Laboratory  
Johns Hopkins Road  
Laurel, MD 20723-6099  
USA  
301-953-5521  
301-953-5910  
john\_benedict@jhuapl.edu



**Technology and the Mine Problem Symposium  
Attendees List**

Lim Beng Boon  
Chartered Ammunition Industries Ltd  
249 Jalan Boon Lay  
Singapore 619523 Singapore  
650-6607-131  
650-265-7003

Willard Randell Bercraft  
General Atomics  
USA

Captain Thomas R. Bernitt  
Commander, Explosive Ordnance  
Disposal Group One  
2424 Rendova Road  
San Diego, CA 92155-5584  
USA  
619-437-0727  
619-577-0727  
619-437-0726  
n00\_at\_eodgru1@cnspl.navy.mil

Jay Bertelli  
Mercury Computers  
199 Riverneck Road  
Chelmsford, MA01824  
USA  
508-256-1300  
508-256-3599

Hal E. Bertrand  
Institute for Defense Analyses  
1801 North Beauregard Street  
Alexandria, VA 22311-1772  
USA  
703-578-2775  
703-931-7792  
hbertrand@ida.org

Matthew C. Beyard  
Naval Surface Warfare Center  
Indian Head Division Code 9510  
101 Strauss Avenue  
Indian Head, MD 20640  
USA  
301-743-4331  
301-743-4196  
mbeyard@xplo.ih.navy.mil

COL, USMC (Ret)  
Edward O. Bierman  
AMA, Ltd  
28 Jacome Way  
Middletown, RI 02842  
USA  
401-849-8900 x 401  
tbierman@amaltd.com

Louis H. Billard  
Naval EOD Technology Div  
Code 50BII  
2008 Stump Neck Road  
Indian Head, MD 20640  
USA  
301-743-6850 x253  
354-6850 x253  
301-743-6947  
billard.eodtc@eodmgate.navsea.navy.mil

Harold Bishop  
Arete Associates  
1725 Jefferson Davis Highway  
Suite 703  
Arlington, VA 22202  
USA  
703-413-0290  
703-413-0295  
hrbishop@arete\_dc.com

Matthew D. Blake  
Lockheed Martin  
1111 Lockheed Martin Way  
O/V2-90 B/55OW  
Sunnyvale, CA 94088-3504  
USA  
408-742-2513  
408-742-8720  
matt.blake@lmco.com

Norman Bleistein  
Center for Wave Phenomena  
Colorado School of Mines  
Golden, CO 80401-1887  
USA  
303-273-3461  
303-273-3478  
norm@dix.mines.edu

**Technology and the Mine Problem Symposium  
Attendees List**

D. Richard Blidberg  
Autonomous Undersea Systems Institute  
86 Old Concord Turnpike  
Lee, NH 03824  
USA  
603-868-3221  
603-868-3283  
blidberg@ausi.org

Ronald R. Blue  
Lockheed Martin  
1725 Jefferson Davis Highway,  
Ste 403  
Arlington, VA 20772  
USA  
703-413-5894  
703-413-5888

Bradley Blume  
Nichols Research Corporation  
P.O. Box 9474  
Panama City, FL 32417-9474  
USA  
904-233-0667  
904-233-1262  
blumeb@puzzler.nichols.com

Professor Albert M. Bottoms  
NPS  
300 Glenwood Circle Apt. 282  
Monterey, CA 93940-4712  
USA  
408-656-3770  
408-878-3770  
408-656-3679  
ambottom@nps.navy.mil

Richard R. Braddock  
SAIC  
1710 Goodridge Drive  
Mc Lean, VA 22101  
USA  
703-821-4420  
703-790-1409  
david.l.stanford@cpmx.saic.com

Claude P. Brancart  
C.S. Draper Laboratory  
555 Technology Square  
Cambridge, MA 02139  
USA  
617-258-3097  
617-258-2942  
brancart@snap.org

Beverly D. Briggs  
CECOM Night Vision Electronics &  
Sensors Directorate  
Night Vision Directorate  
AMSEL RD NV CD ES  
10221 Burbeck Rd., Ste. 430  
Ft. Belvoir, VA 22060-5806  
USA  
703-704-1073  
703-654-1073  
703-654-3001  
shendrix@nvl.army.mil

Mitch Brown  
National Security Affairs,  
Naval Post Graduate School  
589 Dyer Road  
Monterey, CA 93943  
USA  
408-656-2286  
408-656-2949  
msbrown@nps.navy.mil

Dr. Ronald E. Brown  
Tracor Aerospace  
Mine Counter Measures Division  
P.O. Box 196  
San Ramon, CA 94583  
USA  
510-743-3537  
510-820-3132  
rebrown@ttn@aol.com

Don Brutzman  
Naval Postgraduate School  
589 Dyer Road  
Monterey, CA 93943  
USA  
408-656-2149

**Technology and the Mine Problem Symposium  
Attendees List**

Captain Peter W. Bulkeley  
Naval Doctrine Command  
1540 Gilbert Str.  
Norfolk, VA 23511-2785  
USA  
757-445-0561  
757-565-0570  
757-445-0570

Jaime Bunczek  
NSWC Coastal Systems Station  
6703 W. Hwy 98  
Panama City, FL 32407-7001  
USA  
904-234-4947  
904-235-5057

Professor Joel Burdick  
California Institute of Technology  
Mechanical Engineering Dept.  
Robotics, Mail code 104-44  
Pasadena, CA 91125  
USA  
818-395-4139

Captain James M. Burin  
Acting Superintendent, NPS  
Herrmann Hall, East Wing  
Room 301  
Monterey, CA 93943  
USA  
408-656-2581  
408-656-3262

Sean P. Burke  
CECOM Night Vision Electronics &  
Sensors Directorate  
Night Vision Directorate, AMSEL RD NV  
CD ES  
10221 Burbeck Rd., Ste 430  
Ft. Belvoir, VA 22060-5806  
USA  
703-704-1047  
703-654-1047  
703-654-3001  
sburke@nvl.army.mil

Terence C. Burke  
PMS-EOD at NAVEODTECHDIV  
2008 Stump Neck Rd  
Indian Head, MD 20640-5070  
USA  
301-743-6837  
301-743-6973  
burke.eodtc@eodmgate.navsea.navy.mil

Paul L. Callahan  
ARL/PSU  
4001 N.9th St. Suite 106  
Arlington, VA 22203  
USA  
703-243-1160  
703-243-1162

James NMN Campbell III  
NVESD Countermine Division  
10221 Burbeck Rd., Suite 430  
AMSEL-RD-NV-CD-ES  
Ft. Belvoir, VA 22060-5806  
USA  
703-704-2115  
703-654-1041  
jcampbell@nvl.army.mil

Dr. Lawrence Carin  
Duke University  
Dept. of Electrical & Computer  
Engineering  
P.O. Box 90291  
Durham, NC 27708-0291  
USA

David C. Carlton  
NCCOSC RDTE DIV  
53560 Hull Street  
San Diego, CA 92152-5001  
USA  
619-553-3456  
619-553-3468

Alf L. Carroll  
Sippican, Inc  
7 Bavnabns Road  
Marion, MA 02738  
USA  
505-748-1160 ext 375

**Technology and the Mine Problem Symposium  
Attendees List**

Suzanne C. Cattanach  
Analysis & Technology, Inc.  
Route 2, P.O. Box 220  
North Stonington, CT 06359-0220  
USA  
860-599-3910 x2780  
860-599-6508  
scattanach@cc.atinc.com

Nicholas C. Ceradini  
Nothrop Gruman  
Electronic Sensors & Systems Div.  
P.O. Box 746 - MSG8  
Baltimore, MD 21203  
USA  
410-993-9208  
410-765-8463

CDRE J. R. Chapman  
Thomson Marconi Sonar  
Wilkinthrop House  
Templecorrbe  
Somerset BA8 ODH  
United Kingdom  
1-935-44-2231  
1-935-44-2009

Shiou-wen Chen  
University of Delaware  
913 Bowman Dr.  
Lewes, DE 19958  
USA  
302-645-4244  
302-645-4201  
bobchen@uded.edu

LTC Bruce A. Childress  
J7 USACOM  
116 Lakeview, Suite 100  
Suffolk, VA 23435-2697  
USA  
757-686-7292  
564-9100 ext 7292  
757-686-7253  
childres@jtasc.acom.mil

Dr. Nicholas P. Chotiros  
University of Texas at Austin  
Applied Research Laboratories  
P.O. Box 8029  
Austin, TX 78713-8029  
USA  
512-835-3512  
512-835-3259  
chotiros@arlut.utexas.edu

Colin Clark  
Defense Week  
627 National Press Building  
Washington, D.C. 20048  
USA  
202-662-9716  
202-662-9744  
ozjude@juno.com

Floyd L. Clarke  
Wyle Laboratories, Inc.  
1841 Hillside Ave.  
Norco, CA 91760  
USA  
909-737-0871 x419  
909-735-4030  
1clarke@earthlink.nct

Glen Clausen  
Clausen Power Blade  
P.O. Box 1326  
McPherson, KS 67460  
USA  
316-241-6354  
316-733-2848

Dr. Ted R. Clem  
Naval Surface Warfare Center, Dahlgren  
Division  
Coastal System Station  
Code R22  
Panama City, FL 32407-7001  
USA  
904-234-4670  
904-235-5462  
clem\_ted@ccmail.ncsc.navy.mil

**Technology and the Mine Problem Symposium  
Attendees List**

James Clynch  
Naval Post Graduate School  
589 Dyer Road  
Monterey, CA 93943  
USA  
408-656-3268  
872-3268  
408-656-2712  
clynch@nps.navy.mil

Ronald G. Cochran  
Explosive Ordnance Disposal  
/LIC, PM, OST Building 3  
10530 Riverview Road  
Fort Washington, MD20744  
USA  
301-203-2638  
301-203-2641

Charles Colby  
Aero-Nautical Robotics Corp.  
2991 Alexis Dr.  
Palo Alto, CA 94304  
USA  
415-941-9090

Steve L. Collignon  
ONR  
800 North Quincy Street  
Arlington, VA 22217-5660  
USA  
703-696-3039  
703-696-0760  
colligs@onrhq.onr.navy.mil

COL Raul J. Colon  
Interamerican Defense Board  
2600 16th Street, N.W.  
Washington, D.C. 20441  
USA  
202-939-7568  
202-265-7026  
iadc4@nmaa.org

RADM Dennis R. Conley USN  
COMINEWARCOM  
Mine Warfare Command  
325 Fifth Street, S.E.  
Corpus Christi, TX 78419-5032  
USA  
512-939-4860  
512-939-4862  
ndrcl@navtap.navy.mil

Mark J. Connolly  
Dept. of Mechanical Engineering, UCLA  
48-121 Engineering IV,  
P.O. Box 951597  
Los Angeles, CA 90095-1597  
USA  
310-473-2267  
connolly@seas.ucla.edu

Dr. David C. Cook  
United Defense, LP  
4800 E. River Road  
Mpls, MN 55421-1498  
USA  
612-572-6052  
612-572-4900  
david\_cook@fmc.com

Charles C. Cotton  
A&T/GSS  
511 Skyview Drive  
Panama City Beach, FL 32408  
USA  
904-230-3791  
904-230-3810  
charles\_cotton@cc.atinc.com

LCDR James D. Coupe  
NSWC Coastsysta (Code A01)  
6703 W. Hwy 98  
Panama City, FL 32407-7001  
USA  
904-234-4003  
904-436-4003  
904-234-4107

**Technology and the Mine Problem Symposium  
Attendees List**

Cregg K. Cowan  
SRI International  
333 Ravenswood Ave.  
Menlo Park, CA 94040  
USA  
415-859-2403

Michael P. Coyle  
Alliant Techsystems Inc.  
600 2nd St. N.E.  
Hopkins, MN 55343  
USA  
612-931-6352  
612-931-4305

Dr. Gregory K. Crawford  
SRI International  
333 Ravenswood Ave.  
Menlo Park, CA 94025  
USA  
415-859-5530  
415-859-6259  
gcrawfor@unix.sri.com

Tom J. Crocker  
RAHCO International  
P.O. Box 7400  
Spokane, WA 99207  
USA  
509-467-0770  
509-466-0212

Robert A. Cross  
Fraunhofer Center for Research in  
Computer Graphics  
167 Angell St.  
Providence, RI 02906  
USA  
401-453-6363 x113  
401-453-0444  
rcross@crcg.edu

Daniel A. Crute  
Naval Surface Warfare Center/Dahlgren  
6703 West Highway 98  
Panama City, FL 32407-7001  
USA  
904-234-4506  
436-4506  
904-234-4141  
crute\_dan@ccmail.ncsc.navy.mil

Thomas J. Cummins  
The MITRE Corp.  
1820 Dolley Madison Blvd.  
Mc Lean, VA 22102  
USA  
703-883-5853  
703-883-6817  
tcummins@mitre.org

Max C. Current  
JHU/APL  
John Hopkins Road, Bldg. 8-233  
Laurel, MD 20723  
USA  
301-953-5359  
301-953-6620  
chris.current@jhuapl.edu

Robert J. Currie  
Alliant Techsystems  
MN11-1403  
600 Second Street NE  
Hopkins, MN 55343-8384  
USA  
612-931-5867  
612-931-4305

**Technology and the Mine Problem Symposium  
Attendees List**

Keith P. Curtis  
The MITRE Corporation  
1820 Dolley Madison Blvd.  
Mc Lean, VA 22102  
USA

Tom D'Andrea  
NSBIR  
c/o BRTRC  
8260 Willow Oaks Corp. Drive,  
Suite 800  
Fairfax, VA 22031  
USA  
703-204-9277  
703-204-9447  
tandrea@brtrc.com

Charles H. Dabney  
TRW  
2361 Jefferson Davis Hwy  
Arlington, VA 22202  
USA  
703-415-0093  
703-418-1780

LCDR Frank L. Daggett  
COMSURFWARDEVGRU  
NAB Little Creek  
2200 Amphibias Dr.  
Norfolk, VA 23521-2850  
USA  
751-464-7965 x680  
751-464-8295

Ray Daigh  
RAHCO International  
P.O. Box 7400  
Spokane, WA 99207  
USA  
509-467-0770  
509-466-0212  
rahcoeng@dmi.com

Colonel Joseph H. Daves  
52nd Ordnance Group (EOD)  
Fort Gillenn  
Forest Park, GA 30050-5000  
USA  
404-363-5890  
404-797-5890  
404-362-3336  
davesj@ftmcphsn\_emh2.army.mil

Geoff Davis  
Mertz, Inc.  
1018 W. Hartford  
P.O. Box 150  
Ponca City, OK 74602-1443  
USA  
405-762-5646  
405-767-8411

Christopher K. De Bolt  
Naval Explosive Ordnance  
Disposal Tech Div.  
2008 Stump Neck Road  
Indian Head, MD 20640  
USA  
301-743-6850 x247  
301-354-6850  
301-743-6947  
debolt.eodtc@eodmgate.navsea.mil

Dr. James J. De Corpo  
Office of Naval Research  
800 N. Quincy St.  
Balston Tower #1  
Arlington, VA 22217  
USA  
703-696-1300  
703-426-1300  
703-696-4065  
decorpjdonrhq.onr.navy.mil

**Technology and the Mine Problem Symposium  
Attendees List**

Vid Deksheniaks  
Westinghouse Savannah River  
Company  
773-41A Room 279  
Aiken, SC 29808  
USA  
803-725-5480  
803-725-4129  
vid.deksheniaks@srs.gov

Walter E. Dence Jr.  
Coastal Systems Station  
Code A61  
10907 New Hampshire Avenue  
Sliver Spring, MD 20903-5640  
USA  
301-394-1707  
301-290-1707  
301-394-4510  
wdence@nswc.navy.mil

Elise Dick  
K 2 T, Inc  
One South Linden Street  
Duquesne, PA 15110  
USA  
412-469-3150 x19  
412-469-8120  
elise@k2t.com

Dominic DiOrio  
Analysis & Technology  
One Corporate Place  
Middletown, RI 02842-6277  
USA  
410-849-5952 ext3598  
401-847-6660  
dom\_diorio@ima.atinc.com

Timothy M. Doherty  
Army Ordnance Missile & Munition  
ATTN: ATSK-CMT-Z  
Redstone Arsenal, AL 35897-6095  
USA  
205-876-9178  
205-876-5979  
msm@redstone\_emh2.army.mil

BrigGen Dennis Doneen USAF (Ret)  
Battelle, Pacific Northwest National  
Laboratory  
P.O. Box K6-48  
Richland, WA 99352  
USA  
509-372-1465  
509-372-1585  
dd\_doneen@pnl.gov

Donald A. Drayer  
Sanders, A Lockheed Martin Company  
P.O. Box 868  
Mer15-2656  
Nashua, NH 03060  
USA  
603-885-2211  
603-885-7861  
ddrayer@mailgw.sanders.lockheed.  
com

Prof. James N. Eagle  
Naval Postgraduate School  
589 Dyer Road  
Monterey, CA 93943  
USA

James R. Edberg  
CALTECH Jet Propulsion Laboratory  
P.O. Box 1480  
La Canada, CA 91012  
USA  
818-393-3966  
818-354-7694  
james.r.edberg@jpl.nasa.gov

Ira Ekhaus  
SYNAP Corporation  
100 Wildwood Avenue  
Arlington, VA 02174  
USA  
617-641-3295  
617-641-2415  
ekhaus@synacorp.com



**Technology and the Mine Problem Symposium  
Attendees List**

John D. Endsley  
EG & G  
2450 Alamo Ave. S.E.  
Albuquerque, NM 87112  
USA  
505-243-2233  
505-243-1021

Roy E. Erickson  
Esquimalt Defence Research  
Detachment  
B.C.  
250-363-2906  
250-255-2906  
250-363-2856  
erickson@edrd.dnd.ca

Mike Farruella  
Foster Miller  
350 2nd Avenue  
Walthouse, MA 02254  
USA  
617-684-4317

Milton Finger  
Lawrence Livermore National Laboratory  
P.O. Box 808, L-159  
Livermore, CA 94551  
USA  
510-422-6370  
510-423-7354  
finger2@llml.gov

John E. Flanagan  
Northrop Grumman Corp.  
P.O. Box 1488  
895 Oceanic Drive  
Annapolis, MD 21404  
USA  
410-260-5871  
401-260-5393

Barbara Fletcher  
Imetrix Inc.  
1235 Route 28A  
P.O. Box 152  
Cataumet, MA 02534-0152  
USA  
508-564-6460  
508-564-6860  
bfletcher@imetrix.com

Dr. Carl B. Fliermans  
Savannah River Technology Center  
Westinghouse Savannah River Co.  
704-8T  
Aiken, SC 30909  
USA  
803-557-7720  
803-557-7223  
carl.fliermans@srs.gov

Robert W. Floyd  
NCCOSC, RDT&E Division  
Code 372  
San Diego, CA 92152  
USA  
619-553-6264  
619-553-6917  
floyd@nos.mil

Melba C. Ford  
NVESD, Countermine Division  
10221 Burbeck Rd., Suite 430  
Fort Belvoir, VA 22060-5806  
USA  
703-704-2473  
703-654-1032  
mford@nvl.army.mil

Andrew J. Fosina  
Logicon Syscor, Inc.  
484 Viking Drive, Suite 200  
Virginia Beach, VA 23452  
USA  
757-486-4411  
757-486-2651  
afosina@logicon.com

**Technology and the Mine Problem Symposium  
Attendees List**

Russell I. Foster  
BDS Washington  
UKLO c/o U.S. Army ARDE  
Picatinny Arsenal, NJ 07806-5000  
USA  
201-724-6431  
201-724-6300

James J. Franciscovich  
Lockheed Martin Sanders  
P.O. Box 868  
Manchester, NH 03063  
USA  
603-645-5477

Craig A. Freed  
NAVEODTECHDIV  
2008 Stump Neck Road  
Indian Head, MD 20640  
USA  
301-743-6850  
301-354-6850  
301-743-6947

William A. Friedl  
CEROS  
73-4460 Queen Kaahumanu Highway  
Suite 111  
Kailua-Kona, HI  
96740  
USA  
808-327-3350  
808-327-3355  
billf@ceros.org

David E. Frost  
Lockheed Martin - ADO  
15250 Ave. of Science  
San Diego, CA 92128  
USA  
619-451-2604  
frostrow@aol.com

Leolan H. Fry Jr.  
U.S. Navy-Coastal Systems Station  
6703 W. Hwy 98  
Panama City, FL 32407-7001  
USA  
904-235-5460  
904-234-4355  
fry\_lee@ccmail.ncsc.navy.mil

Ferrell W. Furr  
Naval Surface Warfare Center  
Indian Head Division  
101 Strauss Avenue  
Indian Head, MD 20640-5035  
USA  
301-743-6742  
301-743-6719

RADM Paul G. Gaffney II  
Office of Naval Research  
Ballston Centre Tower One  
800 North Quincy Street  
Arlington, VA 22217-5660  
USA  
703-696-4258  
703-696-4065

Vincent D. Galindo  
Lockheed Martin  
1725 Jefferson Davis Hwy. Suite 900  
Arlington, VA 22202  
USA  
703-416-5562  
703-416-5588

LTGEN Robert Gard USA (Ret)  
Monterey Institute of International  
Studies  
425 Van Buren Street  
Monterey, CA 93940  
USA  
408-647-4102  
408-647-4104  
rgard@miis.edu

**Technology and the Mine Problem Symposium  
Attendees List**

Ray Garriott  
GDE Systems  
16250 Technology Dr.  
San Diego, CA 92127  
USA  
619-592-5567  
619-592-5309

Joel B. Gaspin  
Naval Surface Warfare Center  
10901 New Hampshire Avenue  
Silver Spring, MD 20903-5640  
USA  
301-394-2204  
301-290-2204  
301-394-4657

Robert G. Gately  
OASD (SO/LIC)  
The Pentagon  
Room 1D469  
Washington, D.C.  
USA  
703-693-9847  
703-614-6962

Gregory C. Gebhardt  
Raytheon Electronic Systems  
1847 West Main Road  
Portsmouth, RI 02871  
USA  
401-842-2664  
401-842-5214  
gebhardg@ccmail.ssd.ray.com

Mark E. Gebicke  
U.S. General Accounting Office  
441 F. St. N.W., Room 4928  
Washington, D.C. 20548  
USA  
202-512-5140

Colonel Louis C. Gerken  
American Scientific  
3250 Holly Way  
Chula Vista, CA 91910  
USA  
619-422-1754  
619-426-1280

MGEN Clair F. Gill USA  
U.S. Army Engineer Center  
Fort Leonard Wood, MO 65473-5000  
USA  
573-563-6117

Alex Gliksman  
Lawrence Livermore National Lab  
3800 N. Fairfax Dr. #1305  
Arlington, VA 22203  
USA  
703-524-2988  
703-524-2988

Major Timothy G. Goddette  
Mines Countermines & Demo  
ATTN: SFAE-ASM-MCD-C  
10100 Duportail Road, Suite 4  
Ft. Belvoir, VA 22060-5811  
USA  
703-704-1088  
703-654-1967  
703-704-1969  
tgoddett@nvl.army.mil

Leonard P. Gollobin  
Presearch Incorporated  
8500 Executive Park Ave.  
Fairfax, VA 22031  
USA  
703-876-6601  
703-876-6411

Steve Goose  
Human Rights Watch  
1522 K Street, N.W., Suite 910  
Washington, D.C. 20005  
USA  
202-371-6592  
202-371-0124  
gooses@hrw.org

Edward C. Gough Jr.  
APL/UW  
1013 NE 40th Str.  
Seattle, WA 98105-6698  
USA  
206-543-1300

**Technology and the Mine Problem Symposium  
Attendees List**

Myron P. Gray  
Johns Hopkins University  
Applied Physics Lab  
Johns Hopkins Road  
Laurel, MD 20723-6099  
USA  
301-953-5053

COL Robert Greenwalt Jr., USA  
USAES, DCD  
Bldg. 3200 Hope Hall, Room 166  
Fort Leonard Wood, MO 65473-5000  
USA  
573-563-4076  
573-563-4071  
greenwar@wood-vines.army.mil

Helen Greiner  
IS Robotics  
Twin City Office Center, Suite #6  
22 McGrath Highway  
Somerville, MA 02143  
USA  
617-629-0055 x35  
617-629-0126  
helen@isr.com

James D. Grembi  
Office of Programs. Exec. Officer, Mine  
Warfare  
2531 Jefferson Davis Hwy  
Arlington, VA 22242-5167  
USA  
703-602-2231  
703-332-2231  
703-602-2906  
grembi\_james\_d@hq.navsea.navy.mil

Captain David J. Grieve  
Sonalysis, Inc.  
Two Corporate Placw  
Middletown, RI 02840  
USA  
401-849-0400 x149  
401-846-8490  
dgrieve@sonalysis.com

Alfred B. Gschwendtner  
Lincoln Laboratory, Massachusetts  
Institute of Technology  
244 Wood Street, Bld. S  
Lexington, MA 02173-9185  
USA  
617-981-4223  
617-981-4486  
gsch@ll.mit.edu

Steve Haeger  
NAVOCEANO  
Stennis Space Center  
1002 Balch Avenue  
Stennis Space Center, MS 39522  
USA  
601-688-4457  
601-688-4078

Dr. Lyndell Z. Hales  
U.S. Army Corps of Engineers  
3909 Halls Ferry Road  
Attn: CEWES-CP-D  
Vicksburg, MI 39180  
USA  
601-634-3207  
601-634-4253  
l.hales@cerc.wes.army.mil

Richard W. Hall  
Naval Command Control  
Ocean Surveillance Center  
RDT&E Div. 53405 Front Street  
San Diego, CA 92152-6530  
USA  
619-553-1350  
619-553-1350  
619-553-1355  
rhall@nosc.mil

Monica T. Hallisey  
Naval Undersea Warfare Center  
Code 3093, B-1320  
1176 Howell St.  
Newport, RI 02841-1708  
USA  
860-440-6216  
hallisey@A1.vsdec.no.nuwc.navy.mil

**Technology and the Mine Problem Symposium  
Attendees List**

Harry N. Hambric  
U.S. Army CECOM RDEC  
ATTN: AMSEL-RD-NV-CD-ES  
10221 Burbeck Road, Suite 430  
Fort Belvoir, VA 22060-5806  
USA  
703-704-1086  
703-654-1086  
703-704-2432  
David K. Han  
ONR  
800 N. Quincy Street  
Arlington, VA 22217  
USA  
703-696-0517  
703-696-3390  
hand@onrhq.onr.navy.mil

Celeste Z. Hansel  
Coastal Systems Station  
Code 2120  
NSWC, Dahlgren Division  
Panama City, FL 32407  
USA  
904-234-4772  
904-234-4355  
hansel.celeste@ccmail.ncsc.navy.mil

Michael E. Haran  
Lockheed Martin Federal Systems  
9500 Godwin Drive  
Manassas, VA 20110  
USA  
703-367-1397  
703-367-6091  
michael.haran@lmco.com

Kip Harrington  
AlliedSignal Ocean Systems  
15825 Roxford Street  
Sylmar, CA 91342  
USA  
818-833-2610  
818-367-0403  
kip.harrington@alliedsignal.com

Michael M. Harris  
Naval Research Laboratory  
Code 7440  
Stennis Space Center,  
MS 39529-5004  
USA  
601-688-4420  
601-485-4420  
601-688-4863  
mike.harris@nrlssc.navy.mil

John Hart  
Applied Physics Lab  
University of Washington  
1013 N.E. 40th Str.  
Seattle, WA 98105  
USA  
206-543-3223  
206-543-6837

ADM Thomas B. Hayward  
TBH Associates  
2200 Ross Ave, Suite 3800  
Dallas, TX 75201  
USA  
214-978-3803  
214-978-3838

Professor Anthony Healey  
Naval Postgraduate School  
589 Dyer Road  
Monterey, CA 93943  
USA  
408-656-3462

Dr. David C. Heberlein  
U.S. Army CECOM RDEC  
ATTN: AMSEL-RD-NV-OD-CM  
10221 Burbeck Road, Suite 430  
Fort Belvoir, VA 22060-5806  
USA  
703-704-1538  
703-704-1041  
dheber1@nvl.army.mil

**Technology and the Mine Problem Symposium  
Attendees List**

Fred Heinemann  
Global Associates, Ltd  
901 N. Stuart St. Suite 601  
Arlington, VA 22203  
USA  
703-276-9200  
703-276-9208  
bmetzger@adss.globalus.com

Thomas Henderson  
Camber Corporation  
7411 Alban Station Court #B250  
Springfield, VA 22060  
USA  
703-704-2564  
703-654-3001  
thenders@nvl.army.mil

CAPT Daniel L. Hendrickson USN (Ret)  
Hendrickson & Associates  
111 Acaia Way  
Coronado, CA 92118  
USA  
619-437-8534  
619-646-5301

Sue Hendrix  
BRTRC  
10221 Burbeck Rd., Ste 430  
AMSEL-RD-NV-CD-ES  
FT. Belvoir, VA 22060-5806  
USA  
703-704-3277  
703-624-3001  
shendrix@nvl.army.mil

Timothy S. Hennessey  
Naval Surface Warfare Center  
101 Strauss Ave.  
Indian Head, MD 20640  
USA  
301-743-6783 x1  
301-743-6719  
4120d@usdesign.ih.navy.mil

CAPT Bill Herman USN (Ret)  
Rockwell International Corp.  
3370 Miraloma Ave.  
P.O. Box 3105  
Anaheim, CA 92803-3105  
USA  
714-762-3148  
714-762-0661  
waherman@anet.rockwell.com

Dr. Frank L. Herr  
Office of Naval Research  
Ocean, Atmosphere & Space Dept.  
800 North Quincy Street  
Arlington, VA 22217-5660  
USA  
703-696-4125  
703-426-4125  
703-696-2007  
herrf@onrhq.onr.navy.mil

Captian Leslie W. Hewett Jr.  
Analysis & Technology  
2154 North Center St., Suite A105  
North Charleston, SC 29406  
USA  
803-797-2217  
803-797-0195  
whewett@cc.atinc.com

Charles W. Hill Jr.  
Office Mine Warfare  
Asst. PEO Program Analysis Evaluation  
2531 Jefferson Davis Hwy  
Arlington, VA 22242-5167  
USA  
703-602-9807  
703-602-2906  
hill\_charles@hq.navsea.navy.mil

Richard S. Hillyer  
Planning Systems, Inc.  
7923 Jones Branch Drive  
McLean, VA 22102  
USA  
703-734-3473  
703-734-3456  
rhillyer@plansys.com

Dennis R. Hiscock  
1101 Tower House Clarendon Road  
Southsea, Hampshire  
PO52LA  
England  
44-1705-828015

Dr. Owen C. Hofer  
Sparta, Inc.  
4901 Corporate Drive  
Huntsville, AL 35805  
USA  
205-837-5282 x2600  
205-890-2041  
owen\_hofer@huntsville.sparta

Eric Hoffman  
K 2 T, Inc  
One South Linden Street  
Duquesne, PA 15110  
USA  
412-469-3150 x15  
412-469-8120  
eric@k2t.com

The Hon. Allen H. Holmes  
The Pentagon  
Asst. Secretary of Defense  
Room 2E 258  
Washington, D.C. 20301-2500  
USA  
703-693-2985  
703-693-6335

Eric B. Holmes  
Lockheed Martin  
315-456-2691  
315-456-1706

Barbara Honegger, M.S.  
Public Affairs Office  
Naval Postgraduate School  
Home: 3131 Pico Street  
Carmel, CA 93923  
408-622-9584

Andrew E. Hooper  
USA Yuma Proving Ground  
STEYP-TD-ATO  
Yuma, AZ 85365  
USA  
520-328-6111  
520-899-6283  
ahooper@yuma\_emh1.army.mil

RADM Charles F. Horne III  
McDermott Inc./Babcock & Wilcox  
1525 Wilson Blvd., Suite 100  
Arlington, VA 22209  
USA  
803-971-9052  
803-971-0333  
chuckhorne@aol.com

John D. Horton  
COMINWAR COM  
325 5th Street, S.E.  
Corpus Christi, TX 78419-5032  
USA  
512-939-4899 x214  
512-851-4899  
512-939-4898  
nsapcmwc@nemo.nose.mil

Ross C. Houston  
GDE Systems, Inc  
P.O. Box 509008  
San Diego, CA 92150-9008  
USA  
619-592-5081  
619-592-5420

Ernest Howard  
PEO-MIW  
2531 Jefferson Davis Hwy.  
Arlington, VA 22242-5167  
USA  
703-602-5100 x220  
703-602-5105  
howard\_mfke@hq.navsea.navy.mil

Michael D. Howard  
Marine Corps Intelligence Activity  
3300 Russell Road, Suite 250  
Quantico, VA 22134-5100  
USA  
703-784-6160  
703-278-6160  
703-784-2026  
howardm@mqg\_smtp3.usmc.mil

**Technology and the Mine Problem Symposium  
Attendees List**

LTGEN Jefferson Davis Howell Jr.  
Commanding General  
Marine Forces Pacific  
P.O. Box 64108  
Camp H.M. Smith, HI 96861-4108  
USA  
808-477-0057  
808-477-0057  
808-477-0058  
nsapcmfp@nosc.mil

CAPT Wayne Hughes USN (Ret)  
Naval Postgraduate School  
Professor of Operations Research, Code  
C3  
Root Hall, Room 203 A  
Monterey, CA 93943  
USA  
408-656-2484  
408-656-2595

Lee Hunt  
Consultant  
7715 Lookout Court  
Alexandria, VA 22306  
USA  
703-765-1046  
202-334-3695  
1hunt@nas.edu

Claude Jean Huyaux  
Thomson-CSF Services Industrie  
13 Avenue Salvador Allende  
Arcueil Cedex 94117  
France  
+33-1-41-48-40-00  
+33-1-41-48-43-30

Professor Ming Ivory  
James Madison University  
College of Integrated Science  
University Blvd.  
Harrisonburg, VA 22807  
USA  
540-568-2760  
540-568-2747  
IVORYM@JMU.EDU

Michael J. Jennings  
NVESD, Countermine Division  
10221 Burbeck Rd., Suite 430  
Fort Belvoir, VA 22060-5806  
USA  
703-704-1032  
703-654-1032  
mjennin@nvl.army.mil

Jack Jensen  
USA

George M. Johnson  
EODGRU ONE VSE MCM  
2424 Rendova Road  
San Diego, CA 92155-5584  
USA  
619-437-5709  
619-577-4444  
619-437-5766  
progmam@adnc.com

COL Richard H. Johnson (USA,Ret)  
Dyn Meridian  
7939 Lake Pleasant Drive  
Spring field, VA 22153  
USA  
703-461-2257  
703-461-2020  
johnsor@dyniet.com

John E. Jordan  
Sparta/ Pacific Synergistics (PSI)  
PO Box 309  
San Clemente, CA 92674  
USA  
714-492-0804  
714-498-6877

RADM Herbert C. Kaler  
PEO Mine Warfare  
2531 Jefferson Davis Highway  
Arlington, VA 22242-5167  
USA  
703-602-9807  
703-602-2906



**Technology and the Mine Problem Symposium  
Attendees List**

Professor Yutaka Kanayama  
Computer Science Dept., NPS  
589 Dyer Road  
Monterey, CA 93943  
USA  
408-656-2095  
408-878-2095  
408-656-2814  
kanayama@cs.nps.navy.mil

David Kang  
C.S. Draper Laboratories  
555 Technology Square  
Cambridge, MA 02139  
USA  
617-258-4100  
617-258-2474

Dr. Christos A. Kapetanakes  
SFA  
1401 Mc Cormick Drive  
Largos, MD 20774-5322  
USA  
202-767-3135  
202-767-3950

Dr. Vladimir R. Karasik  
Babcock & Wilcox  
Naval Nuclear Fuel Division  
P. O. Box 785  
Lynchburg, VA 24505  
USA  
804-522-6477  
804-522-6905  
karasik@usa.pipline.com

Richard W. Kataoka  
Naval Command Control  
Ocean Surveillance Center  
RDTE Div 53405 Front Str.  
San Diego, CA 92152-6530  
USA  
619-553-1348  
619-553-1348  
619-553-1355  
kataoka@mosc.mil

Gerry Kawamura  
Rockwell International  
350 Collins Road N.E.  
Cedar Rapids, IA 52498  
USA  
319-295-5270  
319-295-5111  
jkawamu@rockwell.cacd.com

CDR Timothy P. Keating  
SACLANT  
7857 Blandy Road, Suite 100  
Code: C-361  
Norfolk, VA 23551-2490  
USA  
757-445-3611  
757-565-3611

Dr. Norris R. Keeler  
KAMAN Diversified Technologies Corp.  
1111 Jefferson Davis Hwy, Ste. 700  
Arlington, VA 22202  
USA  
703-416-2500  
703-416-2512

J.W. Kesner  
Alliant Techsystems, Inc.  
1911 North Fort Meyer Drive  
Suite 601  
Arlington, VA 22209  
USA  
703-558-9431  
703-558-9424  
bill\_kesner@atk.com

Captian Anthony J. Kibble  
Logicon Syscon, Inc.  
10 John Clark Road  
Middletown, RI 02842  
USA  
401-849-6270  
401-849-5630  
akibble@logicon.com

**Technology and the Mine Problem Symposium  
Attendees List**

Professor Mary Kimsey  
James Madison University  
College of Integrated Science &  
Technology  
University Blvd.  
Harrisonburg, VA 22807  
USA  
540-568-2760  
540-568-2747  
KIMSEYMB@JMU.EDU

Major Colin King  
British Army  
73 Massetts Road  
Horley Surrey  
RH6 7EB  
England  
011-44-1293-785-277

Lt. COL Dieter E. Kirchhoff  
MGM  
Diessemer Bruch 150  
Krefeld 47805  
Germany  
++49-2151-555733  
++49-2151-511448  
100704.2566@compuserve.com

Kenneth G. Koller  
MACTEC Idaho Division  
2325 West Broadway, Suite D  
Idaho Falls, ID 83402  
USA  
208-524-5300  
208-524-1411  
kgkoller@srv.net

Michael A. Kolodny  
Army Research Lab  
2800 Powder Mill Road  
Adelphi, MD 20783  
USA  
301-394-3110  
301-394-4605

John H. Korneder  
Sherikon  
P.O. Box 1234  
Gig Harbor, WA  
98335  
USA  
206-857-3486  
206-857-3486  
jkornede@harbornet.com

Jeffrey R. Kramer  
U.S. Army Tradoc Analysis Center  
Attn: ATRC-WAD  
White Sands Missile Range  
White Sands, NM 88002  
USA  
505-678-2249  
505-258-2249  
505-678-1450  
kramerjo.trac.wsmr.army.mil

Dean Krossa  
Bristol Aerospace Limited  
P.O. Box 874  
Winnipeg Manitoba  
R3C 2S4  
Canada  
204-775-8331  
204-774-0195

David N. Langhorne  
British Defence Staff (Navy)  
3100 Massachusetts Ave.  
Washington, D.C. 20008  
USA  
202-588-6727  
202-588-7871  
nlanghor@moduk.org

Francois-Regis Martin- Lauzer  
DGA-DEN Brest Gesma  
BP 42  
Brest Naval 29240  
France  
33-98-22-50-20  
33-98-22-7213

**Technology and the Mine Problem Symposium  
Attendees List**

L/COL. USA Ret Han Ken Lee  
National Security Affairs  
c/o Prof. Ed Olsen  
13020 La Paloma Road  
Los Altos Hills, CA 94022  
USA  
408-656-3906

Michael S. Lee  
Naval EOD Tech Div  
2008 Stump Head Road  
Indian Head, MD 20640  
USA  
301-743-6848  
301-354-6848  
301-743-6947

Mark E. Lehr  
University of California at Riverside  
Dept. of Statistics  
Riverside, CA 92521-0138  
USA  
909-787-3774  
909-787-3286  
mlehr@ucrstat2.ucr.edu

Richard K. Leidigh  
Marine Forces Pacific  
G-5.Science Advisor  
P.O. Box 64119  
Camp H.M. Smith, HI 96861-4119  
USA  
808-477-0139  
808-477-0138  
leidighr@mfp.usmc.mil

Captain Lit Siew Li  
Singapore Armed Forces  
AFPN 0001  
303 Gombak Drive #04-24  
Singapore  
669645  
Singapore  
65-768-2831  
65-768-4445

Steve Lingsch  
Naval Oceanographic Office  
1002 Balch Blvd.  
Stennis Space Center,  
MS 39522-5001  
USA  
601-688-5313  
601-485-5313  
601-688-5101

William C. Lingsch  
Naval Oceanographic Office  
1002 Balch Blvd.  
Stennis Space Center, MS 39522  
USA  
610-688-5858  
610-485-5858  
601-688-4333  
wcl@navo.navy.mil

Yung Y. Liu  
Argonne National Laboratory  
9700 South Cass Avenue  
MS308  
Argonne, IL 60439-4832  
USA  
630-252-5127  
630-252-3250  
yyliu@anl.gov

Dr. R. Kenneth Lobb  
Applied Research Lab  
The Pennsylvania State University  
P.O. Box 30  
State College, PA 16804-0030  
USA  
703-414-8783  
703-415-0116  
rkl4@psu.edu

CDR Philip E. Logan  
Joint Warfighting Center  
Fenwick Road, Bldg. 96  
Ft. Monroe, VA 23651-5000  
USA  
757-726-6407  
757-680-6407  
757-726-6552  
logan@jwfc.army.mil

**Technology and the Mine Problem Symposium  
Attendees List**

CDR Frederic C. Louderback  
GDE Systems Inc.  
P.O. Box 509008  
San Diego, CA 92150-9008  
USA

Dr. Warren E. Loughmiller  
NAVSURFWARCENDIV  
300 Highway 361  
Crane, IN 47522-5001  
USA  
812-854-5412  
812-482-5412  
812-854-1976  
wel703@smtpnwscs.sea06.navy.mil

Steve Loui  
Pacific Marine & Supply Co., Ltd.  
Davies Pacific Center  
841 Bishop Street, Suite 1880  
Honolulu, HI 96813  
USA  
808-531-7001 x15  
808-523-7668

Ronald R. Luman  
Johns Hopkins University  
Applied Physics Lab  
Johns Hopkins Rd., Bldg. 8-237  
Laurel, MD 20723-6099  
USA  
301-953-5239  
301-953-6620  
rondald.luman@ihuapl.edu

Robert C. Lytikainen  
P.O. Box 89  
Spencerville, MD 20868  
USA

Dr. Joeseeph M. Mack  
Los Alamos National Laboratory  
P.O. Box 1663, Mail Stop D410  
Los Alamos, NM 87545  
USA  
505-667-3416  
505-667-7684  
jmmack@lanl.gov

Dr. Wagih H. Makky  
Aviation Security R&D Division  
AAR-520  
Atlantic City Int'l Airport, NJ  
08405  
USA  
609-485-5330  
609-383-1973

Dr. Arnis Mangolds  
Foster-Miller Inc.  
350 Second Avenue  
Waltham, MA 02154-1796  
USA  
617-684-4379  
617-890-3489  
amangolds@foster-miller.com

CDR David G. Markham  
Naval Research Laboratory  
4555 Overlook Aveune, S.W.  
Washington, D.C. 20375  
USA  
202-404-8162  
202-754-8162  
202-404-8183  
markham@utopia.nrl.navy.mil

Louis C. Marquet  
Night Vision & Electronic Sensors  
AMSEL-RD-NV-OD  
10221 Burbeck Rd Suite 430  
Fort Belvoir, VA 22060-5806  
USA  
703-704-1172  
703-654-1172  
703-704-1171  
1marquet@nvl.army.mil

CDR David L. Martin  
OPNAV, CNO  
2000 Navy Pentagon Room SE613  
Washington, D.C. 20390  
USA  
703-697-0044  
703-697-3848

**Technology and the Mine Problem Symposium  
Attendees List**

LT. Stephen D. Martin  
CNO (N096)  
U.S. Naval Observatory  
3450 Massachusetts Ave. N.W.  
Washington, D.C. 20392  
USA  
202-762-1020  
202-762-1020  
202-762-0208

Professor Xavier K. Maruyama  
Institute for Joint Warfare Analysis  
Naval Postgraduate School  
Dept. of Physics, Code Ph/MX  
Monterey, CA 93943  
USA  
408-656-2431  
408-656-2834

Dr. Wen Masters  
Office of Naval Research  
Math, Computer, & Information Science  
Div.  
800 North Quincy Street  
Arlington, VA 22217-5660  
USA  
703-696-4314  
703-696-2611

Dr. Maja Mataric  
VOLEN Center for Complex Systems  
Computer Science Dept.  
Brandeis University Second Floor  
Waltham, MA 02254-9110  
USA  
617-736-2700  
617-736-2741  
maja@es.brandeis.edu

William W. Mathis  
Lockheed Martin Tactical Defense  
Systems  
9255 Wellington Road  
Manassas, VA 20110  
USA  
703-367-3351  
703-367-1637  
william.w.mathis@1mco.com

Robert J. Mauer  
Metratek, Inc.  
12330 Pinecrest Road  
Reston, VA 20191  
USA  
703-620-9500  
703-620-9696

Ronald S. Mc Carter  
Sparta Hardware Systems Sector  
16516 Bernardo Center Drive  
Suite 200  
San Diego, CA 92128-2549  
USA  
619-485-8815  
619-485-6759  
steve\_mccarter@cirdan.sparta.com

Elena M. Mc Carthy  
Naval Undersea Warfare Center,  
Division Newport  
Code 814  
Mechanical Systems Division  
1176 Howell St.  
Newport, RI 02841-1708  
USA  
401-841-7824  
401-841-4991  
mccarthy@c813.npt.nvwc.navy.mil

Thomas S. Mc Crobie  
SFG (A) Fort Campbell  
P.O. Box 627  
Oak Grove, KY 42262  
USA  
502-798-6962  
502-635-6962  
502-798-4115

Steve V. Mc Donald  
AlliedSignal Ocean Systems  
15825 Roxford Street  
Sylmar, CA 91342  
USA  
818-833-2201  
818-364-2491

**Technology and the Mine Problem Symposium  
Attendees List**

James R. Mc Farlane  
International Submarine Engineering  
1734 Broadway Str.  
Port Coquitlam, B.C.  
V3C2M8  
Canada  
604-942-5223  
604-942-7577  
info@ise.bc.ca

Captain Kenneth R. Mc Gruther  
MC Associates  
P.O. Box 1173  
Westcliff, CO 81252  
USA  
719-783-3052  
innovfut@aol.com

Allan H. Mc Lean  
Lockheed Missiles & Space  
512 Walnut Ave.  
Santa Cruz, CA 95060  
USA  
408-742-2507

Curtis A. Mc Vey  
Coastal Systems Station  
Code R32  
Panama City, FL 32407  
USA  
703-695-0574 x 227  
703-697-3808

Professor Robert McGhee  
Computer Sciences Department, Naval  
Postgraduate School  
589 Dyer Road  
Monterey, CA 93943  
USA  
408-656-2026

Robert F. McGurrin  
Raytheon Electronic System  
180 Hartwell Road  
Bedford, MA 01730  
USA  
617-274-3137  
617-274-3161  
robert=f=mcgurrin%amraam%msd  
bed@vines.msd.ray.com

CDR Denis Meanor  
U.S. Naval Observatory  
CNO (N096)  
3450 Mass Ave., NW  
Washington, D.C. 20392-5421  
USA  
202-762-1042  
202-762-1-42  
202-762-1-18

Michael E. Melich  
Naval Postgraduate School  
589 Dyer Road  
Code PH/Mm  
Monterey, CA 93943-5000  
USA  
408-656-3776

William C. Meredith  
U.S. General Accounting Office  
441 G. St. N.W., Room 4928  
Washington, D.C. 20548  
USA  
202-512-5140  
202-512-7982

William R. Metzger  
Global Associates, Ltd.  
901 N. Stuart St., Suite 601  
Arlington, VA 22203  
USA  
703-276-9200  
703-276-9208  
bmetzger@dss.globalus.com

**Technology and the Mine Problem Symposium  
Attendees List**

Michael D. Miggins  
SAIC  
8500 Gruder Bed Road, Suite 120  
P.O. Box 8500  
Newuatou, VA 22122-8500  
USA  
703-550-5435  
703-550-1986  
mikem@dn336mail.saic.com.cvr.cpmssp

Matthew R. Miller  
GSS  
511 Skyview Drive  
Panama City Beach, FL 32408  
USA  
904-230-3810  
matt\_miller@cc.atinc.com

Professor Knox Millsaps  
Mechanical Engineering  
Naval Post Graduate School  
589 Dyer Road  
Monterey, CA 93943  
USA  
408-656-3382

Professor Raj Mittra  
Penn State University  
Applied Res Lab  
P.O. Box 30  
State College, PA 16804  
USA  
814-865-1298  
814-865-1299  
r1mece@enr.psu.edu

Dr. Fabiborz Mokhtari  
Department of Political Science  
Norwich University  
Northfield, VT 05663  
USA  
802-485-2366  
802-485-2252  
fmokhtar@norwich.edu

Dr. Joseph Molitoris  
GRC International  
6802 Silver Ann Drive  
Lorton, VA 22079  
USA  
703-339-7244  
703-550-8276  
xlqm71a@prodigy.com

LTC Jon C. Moneyhun  
Unmanned Ground Vehicles/Systems  
JPO  
Building 3221  
Redstone Arsenal, AL 35898  
USA  
205-955-6995  
205-645-6993  
205-842-0947  
moneyhun\_jc@fhssmtp.redstone.army.mil

CDRE Richard Moore  
Thomson Marconi Sonar  
Wilkinthroop House  
Templecorrbe, Somerset  
BA8 ODH  
United Kingdom  
1-935-44-2231  
1-935-44-2009

LCDR Steven M. Morris  
U.S. Naval War College  
686 Cushing Rd.  
Newport, RI 02841-1207  
USA  
401-841-3233  
401-948-3233  
401-841-4628

CPT(P) Mark A. Moulton  
Tradoc Analysis Center  
Attn: ATRC-WAD, White Sands Missile  
Range  
200 Anniston Ave.  
White Sands, NM 88002  
USA  
505-678-1370  
505-258-1370  
505-678-5104

**Technology and the Mine Problem Symposium  
Attendees List**

Dr. Thomas Muir  
Applied Research Laboratories  
The University of Texas at Austin  
P.O. Box 8029  
Austin, TX 78713  
USA  
512-835-3076  
512-835-3259  
muir@arlut.utexas.edu

Dominique Munoz  
DGA/DSTI  
Stsat-Boite Postale 712  
Route de Guerry, Bourges  
18000  
France  
33-3827-4213  
33-4827-4901

Douglas W. Murphy  
Naval Command Control & Ocean  
Surveillance Center, RDT&L Div.  
53475 Strothe Road  
San Diego, CA 92152-6343  
USA  
619-553-5838  
619-553-5838  
619-553-6356  
murphy@nosc.mil

Richard E. Myers  
ISX Corporation  
4353 Park Terrace Drive  
Weslake Village, CA 91367  
USA  
818-735-6828  
818-706-2056  
rmyers@isx.com

Dr. Richard H. Nadolink  
Naval Undersea Warfare Center  
Code 10, Bld. 990/6  
Newport, RI 02841-1708  
USA  
401-841-6760  
401-948-6760  
401-841-4660  
nadolink!npt.nuwc.navy.mil

Allen D. Nease  
WL/FIVCKF  
Robotics Laboratory  
Tyndall Air Force Base, FL 32403  
USA  
904-283-3725  
904-283-9710  
anease@robosun.tyndall.af.mil

Lawrence J. Nee  
U.S. Army Mines, Countermine, &  
Demolitions  
Attn: SFAE-ASM-MCD-C  
10100 DuPortail Road  
Fort Belvoir, VA 22060-5811  
USA  
703-704-1970  
703-654-1970  
703-704-1969  
lnee@nvl.army.mil

Dr. David Netzer  
Naval Postgraduate School  
589 Dyer Road  
Monterey, CA 93943  
USA  
408-656-3241  
408-656-2038  
netzer@aa.nps.navy.mil

Tuan N. Nguyen  
Naval EOD Tech Div  
2008 Stump Neck Road  
Indian Head, MD 20640  
USA  
301-743-6850 x281  
301-743-6941

Anthony M. Nicoli  
Lockheed Martin Infrared & Imageing  
Sys.  
2 Forbes Road  
Lexington, MA 02173  
USA  
617-863-3586  
617-863-4809  
tony.nicoli@lmco.com



**Technology and the Mine Problem Symposium  
Attendees List**

Professor J. D. Nicoud  
Laboratoire de Microinformatique (LAMI)  
EPFL-INF-Ecublens  
CH-1015, Lausanne  
Switzerland  
41-21-693-2641  
41-21-693-5263  
nicoud@di.cpfl.ch

Richard M. Noble  
Naval Underseas Warfare Center  
Code 3114, B-1320, Room 122  
1176 Howell Street  
Newport, RI 02841-1708  
USA  
401-841-3867

COL Randy Norton  
Mine Warfare PEO-MIW  
2531 Jefferson Davis Hwy.  
Arlington, VA 22242-5167  
USA  
703-602-9808  
703-332-9808  
703-602-2906

LT Jeffrey L. Nowlin  
Naval Undersea Warfare Center  
1176 Howell Str.  
Newport, RI 02841-1708  
USA  
401-841-3353  
401-948-3353  
401-948-4749  
nowlin@c223.npt.nuwc.navy.mil

John J. O'Brien  
EDO Corporation  
14-04 111th Street  
College Point, N.Y. 11356  
USA  
718-321-4200  
718-321-4244

Mike J. O'Connell  
CATERPILLAR  
P.O. Box 470 TC-A  
Mossville, IL 61552-0470  
USA  
309-578-6950  
309-578-3739  
uscatx39@ibmmail.com

Thomas C. O'Connell  
Alliant Techsystems Inc.  
600 2nd St. N.E.  
Hopkins, MI 55343  
USA  
612-931-4306  
612-931-4305

Chris O'Donnell  
Naval EOD Technology Center  
2008 Stump Neck Road  
Indian Head, MD 20640-5070  
USA  
301-743-6850 x 262  
301-354-6850  
301-743-6947  
odonnell.eodtc@eodmgate.navsea.navy.  
mil

Peter O'Neill  
OUSD (A&T)/S&TS-M  
3090 Defense Pentagon  
Washington, D.C. 20301-3090  
USA  
703-695-1468  
703-614-3496  
oneillpm@acq.osd.mil

Major Brigid Ockrassa  
USAES DCD  
104 La Salle  
Waynasville, MO 65583  
USA  
573-563-4074

**Technology and the Mine Problem Symposium  
Attendees List**

Professor Richard C. Olsen  
Naval Postgraduate School  
589 Dyer Road  
Monterey, CA 93943  
USA  
408-656-2019  
408-656-2834  
olsen@physics.nps.navy.mil

Captain Fred G. Orchard  
Naval War College  
686 Cushing Road  
Newport, RI 02841-1207  
USA  
401-841-2103  
401-948-2103  
401-841-4628

James F. Outlaw  
U.S. Army Yuma Proving Ground  
Advanced Technology Office  
USAYPG, ATTN: STEYP-TD-AT  
Yuma, AZ 85365  
USA  
520-328-3278  
520-899-3278  
520-328-6283

Dr. Kevin M. Owen  
Naval Postgraduate School  
589 Dyer Road  
Monterey, CA 93943  
USA  
408-656-2098  
408-656-2099

COL (Ret) Jim Pansegrouw  
Consultant  
P.O. Box 912454  
Silverton  
0127  
South Africa  
+ 27 12 8037290  
+ 27 12 0828928170  
+ 27 12 8037189

David W. Parish  
Omnitech Robotics, Inc  
2640 S. Raritan Circle  
Englewood, CO 80110  
USA  
303-922-7773  
303-922-7775  
dparish@omnitech.com

Captian Richard J. Parish  
Naval Surface Warfare Center  
Dahlgren Division  
Coastal Systems Station  
6703 West Highway 98  
Panama City, FL 32407-7001  
USA  
904-234-4201  
904-436-4201 or 4210  
904-234-4902  
parish)rj\_capt@ccmail.ncsc.navy.mil

Dr. Divyakant Patel  
CECOM Night Vision Electronics &  
Sensors Directorate  
Night Vision Directorate  
AMSEL RD NV CD ES  
10221 Burbeck Rd., Ste 430  
Ft. Belvoir, VA 22060-5806  
USA  
703-704-2505  
703-654-2505  
dpatel@nvl.army.mil

RADM John D. Pearson USN  
COMINWARCOM  
325 Fifth Street, S.E.  
Corpus Christi, TX 78419-5032  
USA  
512-939-4860

Commander-  
Royal Navy Russell Pegg RN  
British Navy Staff-Washington  
3100 Massachusetts Ave NW  
Washington, D.C. 20008  
USA  
202-588-6808  
202-588-7871  
rpegg@moduk.org

**Technology and the Mine Problem Symposium  
Attendees List**

CDR John C. Peterson  
4148 Sunset Lane  
Pebble Beach, CA 93953  
USA  
408-625-6789

Captain William M. Peterson  
Murray G. Peterson Assoc., Inc.  
Jones Cove  
48 Jones Point Road  
South Bristol, MA 04568-4310  
USA  
207-644-8100  
207-644-8200

Dr. Mary C. Pfeifer  
INEL  
P.O. Box 1625  
Idaho Falls, ID 83415  
USA  
208-526-1893  
208-526-0875  
mpc@inel.gov

W. Stephen Piper  
USA

George Pollitt  
COMINEWARCOM  
code N02R  
325 Fifth Street, S.E.  
Corpus Christi, TX 78419  
USA  
512-939-4899  
512-939-4898  
ngwpl@navtap.navy.mil

Richard T. Porter  
Lockheed Martin Missiles & Space  
20 E. Main St. #60  
Los Gatos, CA 95032  
USA  
408-756-8514  
408-756-4488

James N. Price  
U.S. Naval Forces Europe  
CINCUSNAVEUR (021), PSC 802  
P.O. Box 9  
FPO, AE  
09499-0154  
USA  
011-44-171-514-4770  
nsapcne@nosc.mil

Gary C. Prybyla  
Naval Surface Warfare Center  
Indian Head Division  
Indian Head, MD 20640  
USA  
301-743-4884  
301-354-4884  
301-743-4262  
prybyla@jill.ih.navy.mil

Dr. Sidney D. Putnam  
Pulse Sciences, Inc  
600 McCormick Street  
San Leandro, CA 95477  
USA  
510-632-5100 x206  
510-632-5300

Associate Professor Roger D. Quinn  
Mechanical Engineering-C.W.R.U.  
Cleveland, OH 44106-7222  
USA  
216-368-3222  
216-368-6445

Maureen Ann Raley  
OUSD(A&T) S&TS/LW  
3100 Defense Pentagon  
Room 3B1060 Attn: M. Raley  
Washington, D.C. 20301-3100  
USA  
703-697-0854  
703-227-0854  
703-693-7029  
raleyma@acq.usd.mil

**Technology and the Mine Problem Symposium  
Attendees List**

Dr. Steven E. Ramberg  
DON/Office of Naval Research  
800 North Quincy Street  
Arlington, VA 22217-5660  
USA  
703-696-4358  
703-426-4358  
703-696-2007  
rambers@onrhq.onr.nvay.mil

Provost Jackson E. Ramsey  
James Madison University  
College of Integrated Science &  
Technology  
University Blvd.  
Harrisonburg, VA 22807  
USA  
540-568-2760  
540-568-2747  
RAMSEYJE@JMU.EDU

Walter Rankin  
Naval Surface Warfare  
Center/Dahlegren  
Advanced Concepts Office  
Code 10-C  
6703 West Highway 98  
Panama City, FL 32407-7001  
USA  
904-235-5712  
904-436-5712  
904-234-4141  
rankin\_walt@ccmail.ncsc.navy.mil

Thomas G. Ratliff  
Tracor Aerospace  
6500 Tracor Lane  
Austin, TX 78703  
USA  
512-929-4433  
512-929-2980  
tgr@eng1.tracor.com

Captain Richard Reass  
PURIVIS Systems  
5700 Thurston Ave., Suite 205  
Virginia Beach, VA 23451-1618  
USA  
757-460-4725  
757-460-5341  
psireassr@aol.com

Sidney G. Reed  
Naval Studies Board  
2101 Constitution Ave.  
Washington, D.C. 21408  
USA  
202-334-3523

Jason R. Regnier  
CECOM Night Vision Electronics &  
Sensors Directorate  
Night Vision Directorate, AMSEL RD NV  
CD ES  
10221 Burbeck Rd., Ste 430  
Ft. Belvoir, VA 22060-5806  
USA  
703-704-2438  
703-654-1047  
703-654-3001  
jregnier@nvl.army.mil

COL (Ret) Robert R. Renier  
USACOM JTASC  
116 Lake View Parkway  
Suffolk, VA 23435-2697  
USA  
757-686-7843  
757-686-7836

Dennis Reust  
Mertz, Inc.  
1018 W/ Hartford  
P.O. Box 150  
Ponca City, OK 74602-1443  
USA  
405-762-5646  
405-767-8411  
mbays@pcok.com

**Technology and the Mine Problem Symposium  
Attendees List**

David H. Reynhout  
Raytheon Electronic Systems  
1847 West Main Road  
Portsmouth, RI 02871-1087  
USA  
401-842-2184  
401-842-5205

MajGen John E. Rhodes USMC  
Marine Corps Combat Development  
Command  
3300 Russel Road, Ste. 225  
Quantico, VA 22134-5001  
USA  
703-784-3457

Dr. Michael J. Ricard  
C.S. Draper Laboratory  
555 Technology Square  
Cambridge, MA 02139  
USA  
617-258-3019  
617-258-1131  
mricard@draper.com

Les Richards  
Tracor Aerospace  
6500 Tracor Lane  
Maildrop 28-4  
Austin, TX 78725-2070  
USA  
512-929-4792  
512-929-2980  
lhr@eng1.tracor.com

Captain James D. Richardson  
ASN(M/UW)  
1000 Navy Pentagon, Room 5C738  
Washington, D.C. 20350-1000  
USA  
703-695-7949  
703-225-2905  
703-614-4608  
richardson\_dana@hq.secnav.navy.mil

CDR John W. Richmond  
Babcock & Wilcox  
P.O. Box 10548  
Lynchburg, VA 24506-0548  
USA  
804-948-4640  
804-948-4747  
john.w.richmond@mcdermott.com

CDR, RN Michael J. Riley  
Headquarters Royal Marines  
West Battery  
Whale Island, Portsmouth  
Hampshire Po2 BD  
United Kingdom  
44-705 547870  
44-105 547699

LCDR John T. Ririe  
MINEWARTRA CEN  
330 Coral Sea Road  
Ingleside, TX 78362-5000  
USA  
512-776-5549  
512-776-5549  
512-776-5621

Dr. Kathleen J. Robertson  
Booz Allen and Hamilton  
8283 Greensboro Drive  
McLean, VA 22102  
USA  
703-917-2476  
703-902-3338  
robertson\_kathleen@bah.com

Donald Robeson  
Coastal Systems Station, NSW  
6703 West Highway 98  
Panama City, FL 32407-7001  
USA  
904-235-5536  
904-234-4141  
robeson\_don@ccmail.ncsc.navy.mil

**Technology and the Mine Problem Symposium  
Attendees List**

Cassie Robinette  
NSBIR  
c/o BRTRC  
8260 Willow Oaks Corp. Dr.,  
Suite 800  
Fairfax, VA 22031  
USA  
703-205-1526  
703-204-9447  
crobinet@brtrc.com

Dr. William I. Roderick  
SACLANT Undersea Research Centre  
Viale San Bartolomeo, 400  
La Spezia 19138  
Italy  
+39-187-540300  
+39-187-540331  
roderick@saclantc.nato.int

Richard R. Rogowski  
BRTRC  
8260 Willow Oaks Corp. Dr.  
Suite 800  
Fairfax, VA 22031  
USA  
703-205-4528  
703-204-4528  
rogowski@brtrc.com

Jay Roland  
Roland & Associates  
500 Sloat Street  
Monterey, CA 93940  
USA  
408-373-2025  
408-373-2841

David Rossi  
Office of Naval Research  
Industrial Programs Department  
800 N. Quincy Street  
Arlington, VA 22217-5660  
USA  
703-696-4024  
703-426-4448  
703-696-4884  
rossid@onrhq.onr.navy.mil

Dr. Robert Rowntree  
Naval Postgraduate School  
Monterey, CA 93940  
USA  
408-656-3770  
408-655-4956

Charles A. Rowzee  
3009 Greencastle Road  
Burtonsville, MD 20866  
USA  
301-384-9597

Captain Dieter K. Rudolph  
Naval Oceanographic Office  
1002 Balch Blvd.  
Stennis Space Center,  
MS 39522-5001  
USA  
601-688-4203  
601-688-5287  
dkr@navo.navy.mil

Henry L. Rutkowski  
Lawrence Berkeley National Laboratory  
MS 71-259  
1 Cyclotron Road  
Berkeley, CA 94720  
USA  
510-486-4113  
510-486-5788  
hlrutkowski@lbl.gov

Captain Dennis L. Ryan  
DON/Office of Naval Research  
800 North Quincy Street  
Arlington, VA 22217-5660  
USA  
703-696-5123  
703-426-4358  
703-696-2007  
rayand@onrhq.onr.navy.mil

**Technology and the Mine Problem Symposium  
Attendees List**

Dr. Fred Saalfeld  
Office of Naval Research  
Ballston Centre Tower One,  
Room 907  
800 North Quincy Street  
Arlington, VA 22217-5660  
USA  
703-696-4517  
703-696-4065  
saalfef@onrhq.onr.navy.mil

Dr. James M. Sabatier  
University of Mississippi  
NCPA  
University, MS 38677  
USA  
601-232-5404  
sabatier@olemiss.edu

Mr. Yair Sagie  
RAMTA Division  
IAI-RAMTA  
P.O. Box 323  
Beer-Shevr, Israel  
84102  
Israel  
011-972-7-6272231  
011-972-7-6276770

LCDR Paul L. Salerni  
Merlin Technologies, Inc  
910 American Street  
San Carlos, CA 94070  
USA  
415-591-2229  
wwilson910@aol.com

Amos L. Samuel  
ESSEX Corporation  
1430 Springhill Road, #510  
McLean, VA 22102  
USA  
703-556-9400  
703-790-8180  
ssamuel@essexcorp.com

Dr. Walter J. Sarjeant  
SUNY at Buffalo  
ECE Department  
312 Bonner Hall  
Buffalo, NY 14260-1900  
USA  
716-645-2422 x1208  
716-645-5964

Craig Sayre  
Naval Command, Control & Ocean  
Surveillance Center Research  
Development, T.& E. Div, cde D8501  
San Diego, CA  
USA  
619-553-3777  
619-553-2052  
sayre@nosc.mil

Vincent Schaper  
Office of Naval Research (362)  
Industrial Outreach Division  
800 North Quincy Street  
Arlington, VA 22217-5660  
USA  
703-696-8528  
703-426-8528  
703-696-4884  
schapev@onrhq.onr.navy.mil

Dr. Alan Schaum  
Naval Research Laboratory  
Code 562D  
4555 Overlook Ave. SW  
Washington, D.C. 20375  
USA  
202-767-9366  
202-404-7493  
schaum@nrl.navy.mil

Hans G. Schiebel  
Schiebel Instruments, Inc.  
USA

**Technology and the Mine Problem Symposium  
Attendees List**

William Schneck  
CECOM Night Vision Electronics &  
Sensors Directorate  
Night Vision Directorate AMSEL RD NV  
CD ES  
10221 Burbeck Rd., Ste 430  
Ft. Belvoir, VA 22060-5806  
USA  
703-704-2446  
703-654-1047  
703-654-3001  
wschneck@nvl.army.mil

Professor Carl Schneider  
U.S. Naval Academy  
572 Holloway Road  
Annapolis, MD 21402-5062  
USA  
410-293-6663  
410-281-3729  
schneide@nadn.navy.mil

Dr. Charles M. Schoman  
SSII  
3600 Pimlico Place  
Silver Spring, MD 20906  
USA  
301-598-5962  
301-598-9661  
vuac02a@prodigy.com

Dr. Jay Sculley  
Allied Research Corporation  
8000 Towers Crescent Drive,  
Suite 750  
Vienna, VA 22182  
USA  
703-847-5268  
703-847-5334

Dr. Gregory C.L. Searle  
Embassy of Australia  
1601 Massachusetts Ave. NW  
Washington, D.C. 20036  
USA  
202-797-3378  
202-797-1838  
condsa@capcon.net

Carl A. Shaver  
Marine Corps Programs Department  
NOCPACDIV, Fallbrook Det.  
700 Ammunition Road  
Fallbrook, CA 92028  
USA  
619-731-3668  
619-873-3668  
619-731-3484  
shaverc@fb.sbeach.navy.mil

GEN John J. Sheehan USMC  
Supreme Allied Command, Atlantic  
Commander in Chief,  
U.S. Atlantic Command  
1562 Mitscher Avenue, Suite 200  
Norfolk, VA 23551-2490  
USA  
804-445-3284  
804-322-6810  
doorey@acom.mil

Frank B. Shelby  
Space Applications Corp.  
4001 North Fairfax Drive  
Arlington, VA 22203  
USA  
703-524-0701  
703-524-3419  
fshelby@atad.spaceapp.com

Robert Sherman  
U.S. Arms Control & Disarmament  
Agency  
D/AP, Room 5844  
320 21st Street, N.W.  
Washington, D.C. 20451  
USA  
202-647-4622  
202-736-7318  
shermaro@acda.gov



**Technology and the Mine Problem Symposium  
Attendees List**

Charles G. Sienkiewicz  
Applied Physics Laboratory  
University of Washington  
1013 NE 40th Street  
Seattle, WA 98105-6698  
USA  
206-543-1384  
206-543-6785  
chuck@apl.washington.edu

RADM John F. Sigler USN  
Deputy Chief of Staff  
Commander in Chief,  
U.S. Pacific Fleet  
250 Makalapa Drive  
Pearl Harbor, HI 96860-7000  
USA  
808-471-9727  
808-474-5161

Nikolas Simos  
Brookhaven National Laboratory  
Bldg 197c  
Upton, NY 11973  
USA  
516-344-7229  
516-344-7650  
simos@bnl.gov

David P. Skinner  
Department of the Navy  
Coastal System Station,  
Dahlgren Division  
Naval Surface Warfare Center  
Panama City, FL 32407-7001  
USA  
904-235-5291  
904-234-4842

Dale R. Slaboszewski  
Insta-Foam Products, Inc  
1500 Cedarwood Drive  
Joliet, IL 60435  
USA  
815-741-6800 ext 510  
815-741-6822

CDR Darrell H. Smith  
Naval Meteorology & Oceanography  
Command  
Stennis Space Center  
Stennis Space Center,  
MS 39529-5005  
USA  
601-688-4173  
601-485-4173  
601-688-5335  
n32.@cnmoc.navy.mil

Jim Smith  
Aeroflex Laboratories  
100 Smith Street  
Farmington, NY 11735  
USA  
516-391-4635  
516-293-0359  
jimsmith@aeroflex.com

Peter M. Smith  
Naval Research Laboratory  
Code 7240  
Stennis Space Center.  
MS 39527  
USA  
601-688-5267  
601-485-5267  
601-688-4149

Samuel M. Smith  
Florida Atlantic University  
Ocean Engineering  
777 Glades Road  
Boca Raton, FL 33431  
USA  
561-367-3606  
561-367-3885  
smith@oe.fau.edu

Dr. Tamara A. Smith  
900 East Armstrong Street  
Frankfort, IN 46041  
USA  
317-654-6195  
317-659-5275  
tamara@accs.net

**Technology and the Mine Problem Symposium  
Attendees List**

Thomas L. Smith  
OASD SO.LIC Dept. of Defense  
1566 B. Westmoreland St.  
Mc Lean, VA 22101  
USA  
703-693-9847  
703-614-6962

Luther W. Snyder  
Planning Systems, Inc.  
7923 Jones Branch Drive  
Mc Lean, VA 22102  
USA  
703-448-3206  
703-734-3456  
lu\_snyder@plamsys.com

Carl Sorrell  
Rockwell  
3370 Miraloma Ave  
Box 3105  
Anaheim, CA 92647  
USA  
714-762-6971  
714-762-4200  
ccsorrell@anet.rockwell.com

Dr. Gary Dean Sower  
EG&G MSI  
2550 Alamo Ave. S.E.  
Albuquerque, NM 87107  
USA  
505-243-2233

Michael J. Speltz  
Raytheon Electronic Systems  
180 Hartwell Road  
Bedford, MA 01730  
USA  
508-858-4503  
617-274-3161

Michael Stankosky  
Science Applications International Corp.  
1710 Goodridge Drive  
Mc Lean, VA 22102  
USA  
703-448-6348  
703-769-9470  
micheal.stankosky@cpm.saic.com

Diane E. Steinberger  
HQ Defense Special Weapons Agency  
ATTN: PMAC  
6801 Telegraphr Road  
Alexandra, VA 22310  
USA  
703-325-1309  
703-221-1309  
703-325-2953  
steinberger@hq.dswa.mil@ddn

Renata L. Steiner  
OPNAV  
CNO N852N  
2000 Navy Pentagon  
Washington, D.C. 20350-2000  
USA  
703-697-0044  
703-227-0044  
703-697-3808  
cno\_N852N@cno.navy.mil

Dr. William K. Stewart  
Woods Hole Oceanographic Institution  
Deep Submergence Laboratory  
MS #7/Blake  
Woods Hole, VA 02543  
USA  
508-289-2644  
508-457-2191  
kstewart@whoi.edu

Robert H. Stokes  
Tracor Applied Sciences  
6500 Tracor Lane  
Austin, TX 78725  
USA  
512-929-4141  
512-929-2055  
stokes@caliled.tracor.com

**Technology and the Mine Problem Symposium  
Attendees List**

Dr. Larry G. Stolarczyk  
Raton Techology Research, Inc  
P.O. Box 428  
848 Clayton Hwy  
Raton, NM 87740  
USA  
505-445-3607  
505-445-9659  
lstolar@internetmci.com

Professor Renjeng Su  
University of Colorado  
Center for Space Construction  
Campus Box 529  
Boulder, CO 80309-0529  
USA  
303-492-2556  
303-492-0290  
renjeng.su@colorado.edu

Fred U. Sulmer  
Lockheed Martin Federal System  
9500 Godwin  
Manassas, VA 20110  
USA  
703-367-4374

Nicholas J. Susner  
SETS Technology, Inc.  
300 Kahelu Ave. Suite 10  
Milani, HI  
96789  
USA  
808-625-5262  
808-625-2474  
nick@harpo.sets.hawaii.com

Thomas E. Swean Jr.  
ONR  
Code 321 OE  
800 N. Quincy  
Arlington , VA 22217  
USA  
703-696-4025  
703-696-2710

Dr. Mark L. Swinson  
Institute for Advanced Technology  
11316 Jollyville Rd #195  
Austin, TX 78759  
USA  
512-471-9060  
512-471-1381  
swinson@email.iat.utexas.edu

CDR Cy S. Tandy  
PMS-EOD at NAVEODTECHDIV  
2008 Stump Neck Road  
Indian Head, MD 20640-5070  
USA  
301-743-6837 x354  
301-743-6973  
tandy.eodtc@eodmgate.navsea.navy.mil

Dr. Barend J.E. Taute  
CSIR-AEROTEK  
P.O. Box 395  
Pretoria  
0001  
South Africa  
+27(12)841-4063  
+27(12)349-1766  
btaute@csir.co.za

Mr. Leslie C. Taylor  
NSWC/Indian Head  
101 Strauss Ave  
Indian Head, MD 20817  
USA  
301-394-3466  
301-290-3466  
301-394-5835  
lctaylo@nswc.navy.mil

Paul Gerhard Terlaje  
COMOPTEVFOR  
7970 Diven St.  
Norfolk, VA 93505  
USA  
757-444-5546 x3170  
757-564-5546  
757-444-4958  
terlajep@cotf.navy.mil

**Technology and the Mine Problem Symposium  
Attendees List**

Lawrence M. Tierney  
Office of Special Technology  
10530 Riverview Road  
Bldg. 3  
Fort Washinton, MD 20744-5821  
USA  
301-292-8526  
301-203-2641

Maj Perdit K. Tiwari  
Singapore Armed Forces  
AFPN 0001  
303 Gombak Drive #04-24  
Singapore  
669645  
Singapore  
65-768-2831  
65-768-4445

RADM Paul E. Tobin  
CNO (N096)  
U.S. Naval Observatory  
3450 Massachusetts Ave. N.W.  
Washington, D.C. 20392-5421  
USA  
202-762-1020  
202-762-1020  
202-762-0208

Dr. Douglas G. Todoroff  
Office of Naval Research  
800 N. Quincy Street  
Arlington, VA 22217  
USA  
703-696-2485  
703-696-2007  
todorod@onrhq.onr.navy.mil

LTC Michael W. Trahan  
Defense & Arms Control Studies  
DACS-MIT  
292 Main Street (E38-670)  
Cambridge, MA 02139  
USA  
617-258-9440  
617-258-7858  
mtrahan@mit.edu

Dr. Gus P. Tricoles  
GDE Systems, Inc.  
P.O. Box 509009  
San Diego, CA 92150-9009  
USA  
619-675-2818  
619-675-1995

Gary M. Trimble  
Lockheed Martin  
USA  
408-742-7596

Joseph L. Trocino  
Golden West Products International  
15233 Ventura Blvd., P-8  
Sherman Oaks, CA 91403  
USA  
818-981-6400  
818-501-6181  
nmexplo@aol.com

Ric Trotta  
Trotta Associates  
21 Little Bull Court  
Centerport, NY 11721  
USA  
516-424-0494  
516-271-8611  
rictrotta@aol.com

Dr. Allen J. Tulis  
IIT Research Institute  
10 W. 35th Street  
Chicago, IL 60137  
USA  
312-567-4543

Steven A. Tunick  
Hughes Electro-Optical Systems  
BLDG E-1 M/S F150  
P.O. Box 902  
El Segundo, CA 90245  
USA  
310-616-6096  
310-616-2628

**Technology and the Mine Problem Symposium  
Attendees List**

Frank Uhlig Jr.  
U.S. Naval War College  
Code 3  
683 Cushing Road  
Newport, RI 02841-1207  
USA  
401-841-2003  
401-948-2003  
401-841-4258

Martin J. Uram  
Concept Engineering Group Inc.  
610 William Pitt Way  
Pittsburgh, PA 15238-1332  
USA  
412-826-3191  
412-826-3193

Kenneth G. Vaglio  
U.S. Army  
AMSEL-RD-AS-AT  
Fort Monmouth, N.J. 07703-5000  
USA  
908-532-0030  
908-992-0030  
908-427-4168

Tish Vajta-Williams  
Space Imaging  
9351 Grant St., Suite #500  
Thornton, CO 80229  
USA  
303-254-2050  
303-254-2211  
tish@spaceimage.com

Frank E. Varljen  
Varljen Associates  
6508 Shamrock Road  
Manassas, VA 20112-3818  
USA  
703-791-6218  
703-791-6547

LTCOL Dennis Verzera  
Naval Surface Warfare Center  
6703 West Highway 98  
Panama City, FL 32407-7001  
USA  
904-234-4461  
904-436-4461  
904-235-5057

James M. Victorine  
Essex Corp.  
1430 Springhill Road, #510  
Mc Lean, VA 72102  
USA  
703-556-9400  
703-790-8180  
vil@essexcorplcom

Mike Voisine  
The Ensing-Bickford Co.  
660 Hopmcadow Street  
Simsbury, CT 06070  
USA  
860-843-2329  
860-843-2621

Claudia A. Vos  
U.S. Army Yuma Proving Ground  
Advanced Technology Officw  
USAYPG, Attn: STEYP-TD-AT (C.Vos)  
Yuma, AZ 85365  
USA  
410-278-1484  
410-298-1484  
410-278-1475  
cvos@yuma\_emh1.army.mil

Richard M. Walden  
Operation USA  
8320 Melrose Ave. #200  
Los Angeles, CA 90069  
USA  
213-658-8876  
213-653-7846  
opusa@lafn.org

**Technology and the Mine Problem Symposium  
Attendees List**

LT Colin S. Walsh  
COMINWARCOM  
325 Fifth St., S.E.  
Corpus Christi, TX 78419  
USA  
512-939-4860  
512-861-4860  
512-939-4862  
ncsw1@navtap.navy.mil

Donald L. Walters  
Naval Postgraduate School  
589 Dyer Road  
Monterey, CA 93943  
USA  
408-656-2267

Keith B. Ward  
Office of Naval Research  
Code 341  
800 North Quincy  
Arlington, VA 22217-5660  
USA  
703-696-0361  
703-696-1212  
ward@onr.navy.mil

CDR Brian Warren  
Naval Doctrine Command  
Strategy & Concepts Div.  
1540 Gilbert Street  
Norfolk, VA 23511-2785  
USA

Alan R. Washburn  
Naval Postgraduate School  
589 Dyer Road  
Monterey, CA 93943  
USA  
408-656-3127

Kennard Watson  
NSWC Coastal Systems Station  
Code R11  
6703 W. Hwy 98  
Panama City, FL 32407-7001  
USA  
904-234-4643  
904-235-5374  
watsonk@atcf.ncsc.navy.mil

Thomas Alan Watson  
7970 Diven St.  
Norfolk, VA 23505  
USA  
751-444-5546 x3119  
751-564-5546  
751-444-3958

Robin M. Watters  
Sonalysts, Inc.  
2 Corporate Pl.  
Middletown, RI 02842  
USA  
401-849-0400 x121  
401-846-8490  
rwatters@sonalysts.com

CDR (Ret) F. G. West Jr.  
Integrated Systems Center  
56 Parkwood Ave.  
Charleston, SC 29403  
USA  
803-744-7472  
803-744-7463  
mwest@iscvb.com

Abby W. Westerman  
NCCOSC RDTE DIV  
53560 Hull Street D745  
San Diego, CA 92152-5001  
USA  
619-553-1909  
619-553-3468  
abby@nosc.mil

**Technology and the Mine Problem Symposium  
Attendees List**

John P. Wetzel  
WL/FIVCF, Robotics Laboratory  
Tyndall Air Force Base. FL 32403  
USA  
904-283-3725  
904-283-9710  
jwetzel@robosun.tyndall.af.mil

Edward Whitman  
U.S. Naval Observatory  
Oceanographer of the Navy  
3450 Massachusetts Ave. NW  
Washington, D.C. 20392-5421  
USA  
202-762-1026  
202-762-1020  
202-762-0208  
096T@iceab,ysbi.navy.mil

Julius C. Wicke  
Coastal Systems Station,  
Dahlgren Division, NSWC  
6703 W HWY 98  
Panama City, FL 32407-7001  
USA  
904-234-4804  
904-436-4804  
904-234-4450  
wicke)charles@ccmail.ncsc.navy.mil

Dr. Ray Widmayer  
Mine Countermeasures Branch  
Expeditionary Warfare Directorate, ICN  
Navy 2000, N852T, the Pentagon  
Washington, D.C. 20350  
USA  
703-697-0044

Michael Willey  
Physics International Company  
2700 Merced Street  
P.O. Box 5010  
San Leandro, CA 94577  
USA  
510-577-7245  
510-577-7108  
mjwilley@corp.olin.com

Jody Williams  
Vietnam Veterans of America  
Foundation  
2001 S. St. NW  
RR#1 P.O. Box 891  
Putney, VT 05346  
USA  
802-387-2080  
802-387-2081  
banmines@soverinet

RADM Richard D. Williams III  
Program Executive Officer,  
Mine Warfare  
2531 Jefferson Davis Highway  
Arlington, VA 22242-5167  
USA  
703-602-9807  
703-602-2906  
williams\_richard\_d\_@hq.navsea.  
navy.mil

Prof. Oscar B. Wilson  
Naval Postgraduate School  
589 Dyer Road  
Monterey, CA 93943  
USA  
408-656-2729

Walter A. Wilson  
Merlin Technologies  
910 American Street  
San Carlos, CA 94070  
USA  
415-591-2229  
wwilson910@aol.com

LCDR Gary R. Windhorst  
Bureau of Naval Personnel  
(PERS 416)  
2 Navy Annex  
Washington, D.C. 20370  
USA  
703-693-1973  
703-223-1973  
703-614-5184

**Technology and the Mine Problem Symposium  
Attendees List**

Richard J. Wold  
Geometrics, Inc  
395 Jara Drive  
Sunnyvale, CA 94089  
USA  
408-734-4616  
408-745-6131  
rwold@geom.geometrics.com

Tom Wollny  
QRC  
5 Mandeville Court  
Monterey, CA 93940  
USA  
408-622-0240  
408-644-0946  
tom@qrc

Dr. Ronald L. Woodfin  
Sandia National Laboratories  
MS 0860  
P.O. Box 5800  
Albuquerque, NM 87185-0860  
USA  
505-844-3111  
505-844-7020  
rlwood@sandia.gov

Arthur St.C. Wright  
Williamson & Associates Inc.  
731 N. Northlake Way  
Seattle, WA 98103  
USA  
206-547-1133  
206-547-3773

Major George G. Wright  
Defense Evaluation Support Activity  
2251 Wyoming Blvd  
Kirtland AFB, NM 87119  
USA  
505-260-2711  
505-260-2701  
wright@desa.osd.mil

Dr. James Wright  
ERIM  
4400 Highway 20 East  
Suite 407  
Niceville, FL 32578-9735  
USA  
904-897-4489  
904-897-3938  
jwright@erim.org

Christopher A. Wynn  
EODGRU One  
VSW Test DECT  
EODMU Three  
NAP Coronado, CA 92155  
USA  
619-553-1530  
619-553-1530  
wynnc@nosc.mil

Dr. William M. Wynn  
Naval Surface Warfare Center  
Dahlgren Division  
Coastal Systems Station  
Panama City, FL 32407-5000  
USA  
904-234-4682  
904-436-4682  
904-235-5462  
wynn.mike@ccmail.ncsc.navy.mil

Maj Kong Nee Yeo  
Singapore Armed Forces  
AFPN 0001  
303 Gombak Drive #04-24  
Singapore  
669645  
Republic of Singapore  
65-768-2831  
65-768-4445



**Technology and the Mine Problem Symposium  
Attendees List**

Captain Charles Young  
Department of the Navy  
Navy Unmanned Undersea Vehicles  
2531 Jefferson Davis Highway  
Arlington, VA 22242-5369  
USA  
703-604-6052 x543  
604-6052 x543  
703-604-6056  
young\_charles@hq.navsea.navy.mil

Gary R. Young  
Night Vision & Electronic Sensors  
Directorate  
10221 Burbeck Rd.,  
Attn: AMSEL-RD-NV-OD  
Fort Belvor, VA 22060-5806  
USA  
703-704-1593  
703-654-1593  
703-704-1171

Liane Young  
Office of Naval Research  
800 North Quincy Street  
BCT #1, Room 915  
Arlington, VA 22217-5660  
USA  
703-696-0749  
703-696-5940  
young1@onrhq.onr.navy.mil

Suzy V. Young  
U.S. Army MICOM  
AMSMI-RD-AC  
Redstone Arsenal, AL 35898  
USA  
205-876-1240  
205-876-0640  
young\_sd@redstone.army.mil

COL George NMN Zahaczewsky  
OASD(SO.LIC)F&R  
The Pentagon  
Room 1A674B  
Washington, D.C. 20301-2500  
USA  
703-693-5224 x23  
703-223-5224/23  
703-693-3030  
williamm@policy.policy.osd.mil

Ed Zdankiewicz  
Mine & Undersea Warfare 2000 Navy  
Room 5C 738  
The Pentagon  
Washington, D.C. 20350  
USA  
703-695-2905  
zdankiewicz\_edward@shq.secnav.navy.  
mil

# **Appendix C**

**Information  
and  
Membership Application Form  
for the  
Mine Warfare Association  
(MINWARA)**

## THE MINE WARFARE ASSOCIATION AND MINE LINES

The Mine Warfare Association (MINWARA) was formed as a Not-for-Profit Corporation in the Commonwealth of Virginia to educate and increase awareness about Mine Warfare, Mine Threats and the Mine Problem; to enhance communication among individuals and organizations concerned with all aspects of mine warfare, including mining and mine design, mine countermeasures and counter-mine activity, and demining and remediation of areas contaminated by mines, unexploded ordnance, and hazardous chemical, biological and radiological materials; to provide a focus both in the U.S. and abroad for efforts such as the development of international protocols for the control of the spread and proliferation of mines and mine technologies to nations, factions and agencies indiscriminate and irresponsible in their use; and to promote the application of appropriate technology to expedite minefield neutralization in both military and humanitarian contexts.

MINWARA meets the requirements of a 501(c)(3) corporation under the Internal Revenue Act of 1954 as amended.

The financial resources needed to conduct the business of MINWARA and to prepare, publish and disseminate the organization's newsletter, MINE LINES, come from membership fees and contributions from individuals and corporations. Officers and Directors serve without compensation and there is no subsidy for the publication or mailing of MINE LINES. Such revenues as may be derived from Symposia, workshops and other educational and research activities are used to offset the expenses and costs of event preparation.

Through MINE LINES, MINWARA seeks to stimulate professional exchange and to announce the periodic workshops and meetings that the organization sponsors and co-hosts. These events are in addition to the sesquiannual Symposium on Technology and the Mine Problem.

The Symposium Announcement and Registration Issue of MINE LINES were sent to an expanded mailing list. This was made possible by planning funds from the Office of Naval Research. The PROCEEDINGS of this Symposium will be mailed to each Registrant in Spring 1997 as part of the Registration fee.

A MINWARA Membership Application form is available in this Program or at the Registration Desk throughout the Symposium. Information on Individual and Corporate Membership classes and benefits may be obtained by writing MINWARA, P.O. Box 185, Newington, VA 22122-0185, or from the MINWARA Secretary-Treasurer, Dr. Joseph Molitoris, at (703) 339-7244 or on the World Wide Web at <http://www.minwara.org>.

## MINE WARFARE ASSOCIATION MEMBERSHIP APPLICATION

NAME \_\_\_\_\_

ADDRESS \_\_\_\_\_

TEL (HOME) \_\_\_\_\_ TEL (OFFICE) \_\_\_\_\_

FAX \_\_\_\_\_ E-MAIL \_\_\_\_\_

PROFESSIONAL AFFILIATION \_\_\_\_\_

CITIZEN OF \_\_\_\_\_

MEMBERSHIP CLASS FOR WHICH APPLYING \_\_\_\_\_

Charter Individual: \$100. Active Individual: \$25;

For Corporate Membership classifications, and fees please contact

MINWARA Secretary-Treasurer, Dr. Joseph Molitoris at (703) 339-7244.

MINWARA year is 1 October to 30 September.

REMITTANCE \$ \_\_\_\_\_

AREAS OF INTEREST AND EXPERTISE (Please check as many as apply):

OPERATIONAL \_\_\_\_\_ TECHNOLOGICAL \_\_\_\_\_ ARMS CONTROL \_\_\_\_\_

HUMANITARIAN \_\_\_\_\_ DEMINING \_\_\_\_\_ WEAPONRY \_\_\_\_\_

HISTORICAL \_\_\_\_\_ REMEDIATION OF CONTAMINATED AREAS \_\_\_\_\_

OTHER (Please Specify) \_\_\_\_\_

WILLINGNESS TO TAKE ACTIVE PART IN MINWARA AS AN:

OFFICER \_\_\_\_\_ BOARD MEMBER \_\_\_\_\_ EVENT \_\_\_\_\_

SPONSOR \_\_\_\_\_

RESOURCE PERSON \_\_\_\_\_ EVENT ORGANIZER \_\_\_\_\_ MEMBERSHIP \_\_\_\_\_

OTHER (Please Specify) \_\_\_\_\_

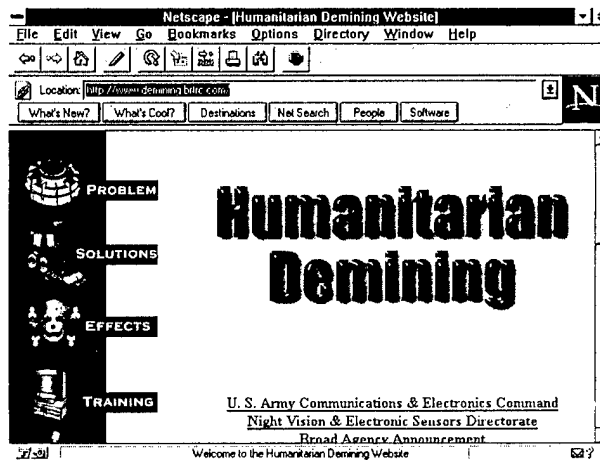
Mail with your Remittance to:

MINWARA, P. O. Box 185, Newington, VA 22122-0185

<http://www.minwara.org>

# APPENDIX D

# Humanitarian Demining On the Internet

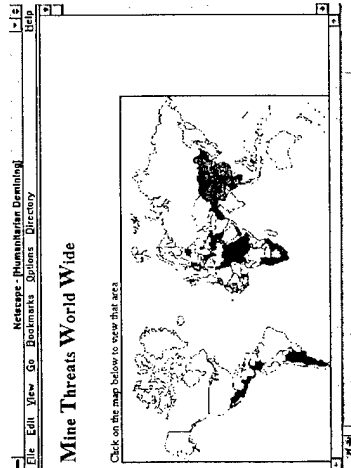


Available On-line  
<http://www.demining.brtrc.com>

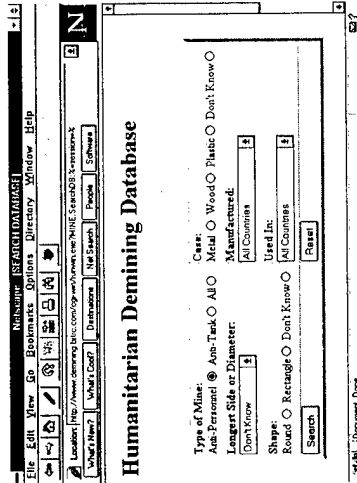
- Quick and Easy Access to Pertinent Information

# Problems

Pinpoint world problem areas



Search the mine database based on physical characteristics and location of mines

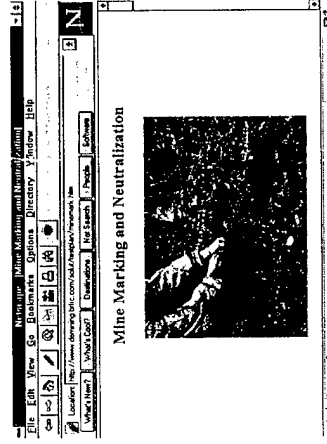
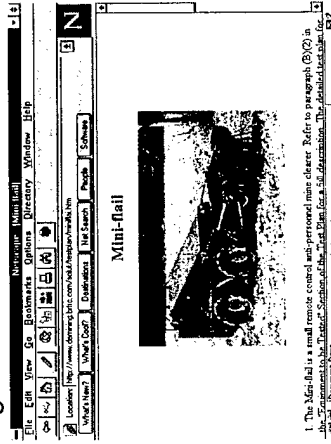


Browse other Mine Related information sources on the internet

- Comprehensive On-line Information and Searchable Databases

# Solutions

Explore current solutions developed by the Night Vision and Electronic Sensors Directorate, Countermine Division and other organizations



# Effects

Information of mine effects and emergency medical treatment

- Continuously Updated

# Training

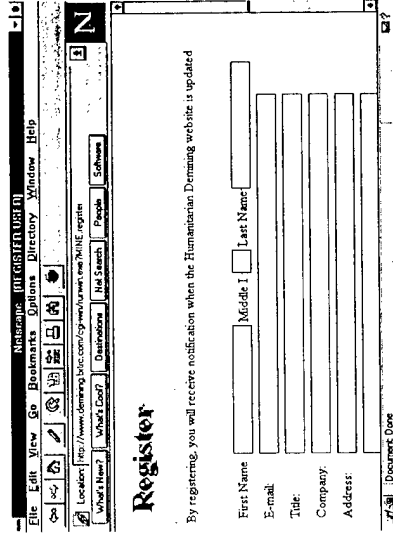
Use the latest Interactive Training Tools. Learn what to do if you encounter a mine

# Feedback

Input your feedback regarding the Humanitarian Demining Technologies Program. Interact real-time with others regarding Humanitarian Demining

# Register

Register for automatic notification of updates to the Humanitarian Demining Website



For More Information  
Please Contact

The Humanitarian Demining Technologies  
Development Program Office

Mr. Ricardo Gonzalez  
703-704-2493  
rgonzale@nvl.army.mil

Mr. Ivan Martinez  
703-704-2501  
imartin@nvl.army.mil

Fax 703-704-3001

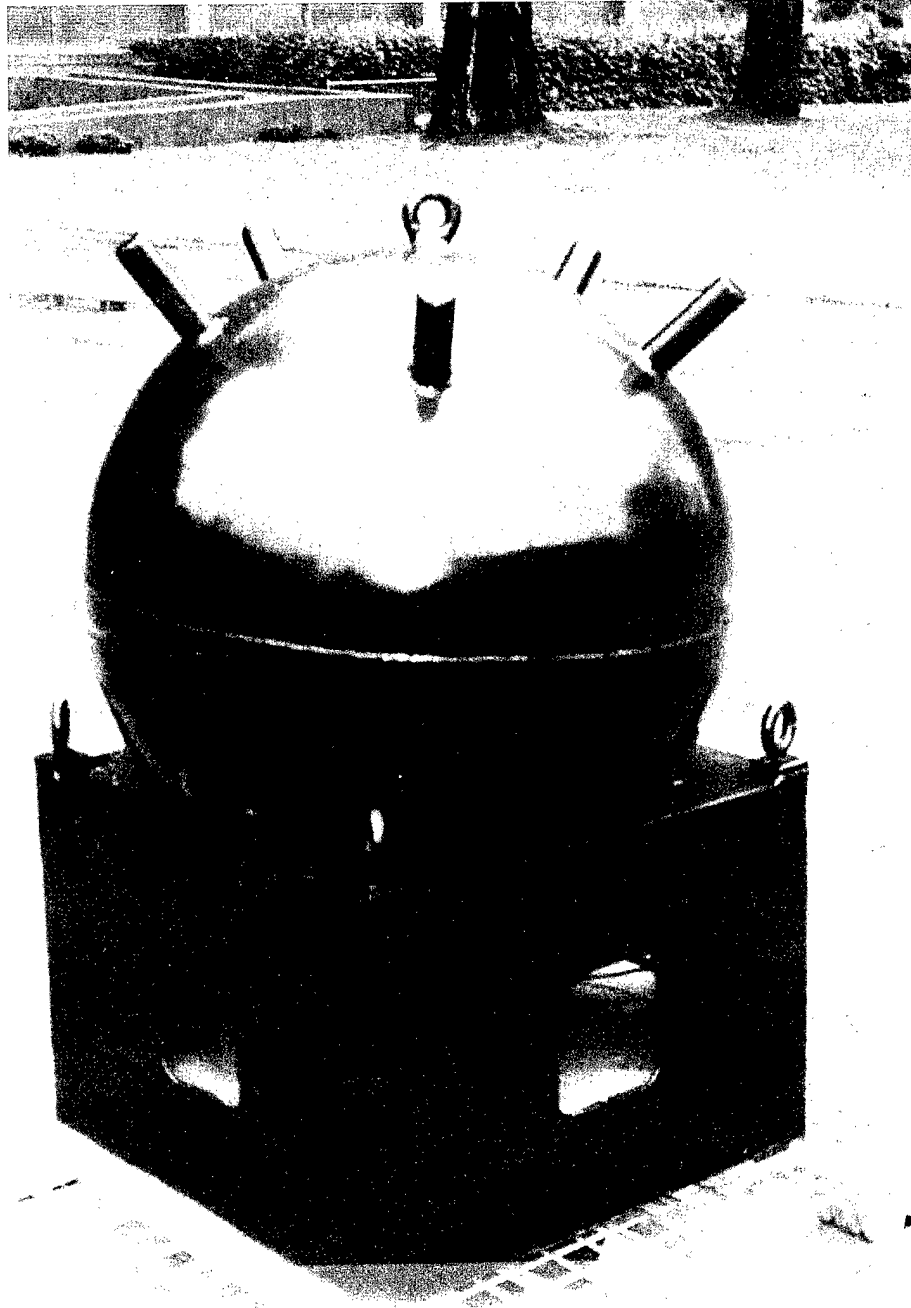


**REPORT DOCUMENTATION PAGE**Form Approved  
OMB No. 0704-0188

Public reporting burden for this collection of information is estimated to average 1 hour per response, including the time for reviewing instructions, searching existing data sources, gathering and maintaining the data needed, and completing and reviewing the collection of information. Send comments regarding this burden estimate or any other aspect of this collection of information, including suggestions for reducing this burden to Washington Headquarters Services, Directorate for Information Operations and Reports, 1215 Jefferson Davis Highway, Suite 1204, Arlington, VA 22202-4302, and to the Office of Management and Budget, Paperwork Reduction Project (0704-0188), Washington, DC 20503.

1. AGENCY USE ONLY (Leave blank)		2. REPORT DATE <b>January 21, 1997</b>	3. REPORT TYPE AND DATES COVERED <b>Final Nov. 18-21, 1996</b>	
4. TITLE AND SUBTITLE <b>Proceedings of the Technology and the Mine Problem Symposium</b>			5. FUNDING NUMBERS  <b>N00014-96-1-1300</b>	
6. AUTHOR(S)  <b>Albert M. Bottoms, General Editor Barbara S. Honegger, M.S., Proceedings Editor</b>				
7. PERFORMING ORGANIZATION NAME(S) AND ADDRESS(ES) <b>Mine Warfare Association P.O. Box 185, Newington, VA 22122-0185 Albert M. Bottoms, President Joseph Molitoris, Secretary-Treasurer</b>			8. PERFORMING ORGANIZATION REPORT NUMBER  <b>ONR Report 1</b>	
9. SPONSORING / MONITORING AGENCY NAME(S) AND ADDRESS(ES) <b>Naval Postgraduate School (Code UW) 58 9 Dyer Road, Root Hall 200A Monterey, CA 93943 James N. Eagle, Professor and Chair, USW</b>			10. SPONSORING / MONITORING AGENCY REPORT NUMBER  <b>N/A</b>	
11. SUPPLEMENTARY NOTES  <b>Report of the Second in a Series of Major Technical Symposia on Technology and the Mine Problem</b>				
a. DISTRIBUTION / AVAILABILITY STATEMENT  <b>Unlimited distribution</b>			12. DISTRIBUTION CODE  <b>No Limitations; Available to public</b>	
13. ABSTRACT (Maximum 200 words)  This volume of Invited and Contributed Papers constitutes the PROCEEDINGS of the Second Symposium on Technology and the Mine Problem. This series is held at the Naval Postgraduate School, Monterey, CA. Major technical symposia occur every 18 months. All aspects of Mine Warfare are included: mining, military mine countermeasures on land and at sea, and Humanitarian DeMining. There is considerable emphasis on emerging technologies, particularly those that support increasing degrees of autonomy in minecountermeasures/countermine operations. The PROCEEDINGS includes statements regarding military requirements by very senior officers in the Army, Navy, Marine Corps, and OSD. The technical papers can be thought of as the responses from academe, industry, and the government laboratories to those requirements.				
14. SUBJECT TERMS <b>Mine Warfare, Humanitarian DeMining, Mine Countermeasures, Countermine, Sensors, Autonomous Systems, Explosive, Historical Record, Market, Requirements, Marine Corps, Army, Navy, Mechanical Sweeping, Obstacles, landmines, Magic Lantern, Clausen Power Blade, Ground Penetrating Radar</b>			15. NUMBER OF PAGES <b>1634</b>	
			16. PRICE CODE <b>N/A</b>	
17. SECURITY CLASSIFICATION OF REPORT <b>Unclassified</b>	18. SECURITY CLASSIFICATION OF THIS PAGE <b>Unclassified</b>	19. SECURITY CLASSIFICATION OF ABSTRACT <b>Unclassified</b>	20. LIMITATION OF ABSTRACT  <b>None</b>	





**Practice Naval mine provided the Naval Postgraduate School courtesy of NRaD San Diego**