



Calhoun: The NPS Institutional Archive
DSpace Repository

Theses and Dissertations

1. Thesis and Dissertation Collection, all items

1986-06

An experimental investigation of combustion modulation techniques for a solid fuel ramjet

Lowe, Stephen R.

<https://hdl.handle.net/10945/21845>

This publication is a work of the U.S. Government as defined in Title 17, United States Code, Section 101. Copyright protection is not available for this work in the United States.

Downloaded from NPS Archive: Calhoun



Calhoun is the Naval Postgraduate School's public access digital repository for research materials and institutional publications created by the NPS community. Calhoun is named for Professor of Mathematics Guy K. Calhoun, NPS's first appointed -- and published -- scholarly author.

Dudley Knox Library / Naval Postgraduate School
411 Dyer Road / 1 University Circle
Monterey, California USA 93943

<http://www.nps.edu/library>



DUBLEY KNOX LIBRARY
NAVAL POSTGRADUATE SCHOOL
MONTEREY, CALIFORNIA 93943-5002

NAVAL POSTGRADUATE SCHOOL

Monterey, California



THESIS

AN EXPERIMENTAL INVESTIGATION OF
COMBUSTION MODULATION TECHNIQUES FOR
A SOLID FUEL RAMJET

by

Stephen R. Lowe

June 1986

Thesis Advisor:

David W. Netzer

Approved for public release; distribution is unlimited

T230698

REPORT DOCUMENTATION PAGE

a REPORT SECURITY CLASSIFICATION Unclassified		1b. RESTRICTIVE MARKINGS	
a SECURITY CLASSIFICATION AUTHORITY		3 DISTRIBUTION/AVAILABILITY OF REPORT Approved for public release; distribution unlimited	
b DECLASSIFICATION/DOWNGRADING SCHEDULE		5 MONITORING ORGANIZATION REPORT NUMBER(S)	
PERFORMING ORGANIZATION REPORT NUMBER(S)		7a NAME OF MONITORING ORGANIZATION Naval Postgraduate School	
a NAME OF PERFORMING ORGANIZATION Naval Postgraduate School	6b OFFICE SYMBOL (If applicable) 67	7b. ADDRESS (City, State, and ZIP Code) Monterey, California 93943-5000	
c ADDRESS (City, State, and ZIP Code) Monterey, California 93943-5000		9 PROCUREMENT INSTRUMENT IDENTIFICATION NUMBER	
a NAME OF FUNDING/SPONSORING ORGANIZATION Naval Weapons Center	Bb OFFICE SYMBOL (If applicable)	10 SOURCE OF FUNDING NUMBERS	
c ADDRESS (City, State, and ZIP Code) China Lake, Ca 93555		PROGRAM ELEMENT NO	PROJECT NO N6053086 WR30021
		TASK NO	WORK UNIT ACCESSION NO
1 TITLE (Include Security Classification) AN EXPERIMENTAL INVESTIGATION OF COMBUSTION MODULATION TECHNIQUES FOR A SOLID FUEL RAMJET			
2 PERSONAL AUTHOR(S) Lowe, Stephen R.			
3a TYPE OF REPORT Master's Thesis	13b TIME COVERED FROM _____ TO _____	14 DATE OF REPORT (Year, Month, Day) June 1986	15 PAGE COUNT 39
6 SUPPLEMENTARY NOTATION			
7 COSATI CODES		18 SUBJECT TERMS (Continue on reverse if necessary and identify by block number)	
FIELD	GROUP	Swirl, Regression Rate, Gas Injection, Equivalence Ratio, Combustion	
9 ABSTRACT (Continue on reverse if necessary and identify by block number) An experimental investigation was conducted to examine the effects of inlet air swirl and secondary gas injection on the combustion properties in a solid fuel ramjet. Tests were conducted with both HTPB and PMM fuels in order to obtain general results. The swirl tests were conducted at high and low air mass fluxes with equivalence ratios less than unity. Swirl was found effective for increasing the fuel regression rate but the magnitude was highly dependent upon motor geometry, fuel type and operating environment. The gas injection tests included hydrogen at low equivalence ratios, and nitric oxide and nitrous oxide at high equivalence ratios. Secondary injection generally resulted in increases in combustion pressure in agreement with equilibrium, adiabatic combustion expectations.			
20 DISTRIBUTION/AVAILABILITY OF ABSTRACT <input checked="" type="checkbox"/> UNCLASSIFIED/UNLIMITED <input type="checkbox"/> SAME AS RPT <input type="checkbox"/> DTIC USERS		21 ABSTRACT SECURITY CLASSIFICATION Unclassified	
22a NAME OF RESPONSIBLE INDIVIDUAL David W. Netzer		22b TELEPHONE (Include Area Code) (408) 646-2980	22c OFFICE SYMBOL 67Nt

Approved for public release; distribution is unlimited.

An Experimental Investigation of Combustion Modulation
Techniques for a Solid Fuel Ramjet

by

Stephen R. Lowe
Lieutenant, United States Navy
B.S., Auburn University, 1978

Submitted in partial fulfillment of the
requirements for the degree of

MASTER OF SCIENCE IN ENGINEERING SCIENCE

from the

NAVAL POSTGRADUATE SCHOOL
June 1986

ABSTRACT

An experimental investigation was conducted to examine the effects of inlet air swirl and secondary gas injection on the combustion properties in a solid fuel ramjet. Tests were conducted with both HTPB and PMM fuels in order to obtain general results. The swirl tests were conducted at high and low air mass fluxes with equivalence ratios less than unity. Swirl was found effective for increasing the fuel regression rate but the magnitude was highly dependent upon motor geometry, fuel type and operating environment. The gas injection tests included hydrogen at low equivalence ratios, and nitric oxide and nitrous oxide at high equivalence ratios. Secondary injection generally resulted in increases in combustion pressure in agreement with equilibrium, adiabatic combustion expectations.

TABLE OF CONTENTS

I. INTRODUCTION ----- 10

II. DESCRIPTION OF APPARATUS ----- 15

 A. RAMJET MOTOR ----- 15

 B. AIR AND GAS SUPPLY AND CONTROL SYSTEM ----- 16

III. EXPERIMENTAL PROCEDURES ----- 21

 A. CALIBRATION ----- 21

 B. DATA EXTRACTION ----- 21

 C. REACTING FLOW TESTS ----- 22

IV. RESULTS AND DISCUSSION ----- 25

 A. INLET AIR SWIRL ----- 25

 B. GASEOUS INJECTION ----- 28

V. CONCLUSIONS AND RECOMMENDATIONS ----- 36

LIST OF REFERENCES ----- 37

INITIAL DISTRIBUTION LIST -----38

LIST OF TABLES

1.	SWIRL TEST FUEL GRAIN CHARACTERISTICS -----	30
2.	SWIRL TEST RESULTS--MASS FLOW RATES -----	30
3.	SWIRL TEST RESULTS--COMBUSTION PROPERTIES -----	31
4.	SUMMARY OF GASEOUS INJECTION TESTS -----	32

LIST OF FIGURES

1.	SCHEMATIC OF SIMPLE SFRJ -----	11
2.	SCHEMATIC OF SOLID FULE RAMJET ASSEMBLY -----	17
3.	STEP INSERT AND ELEMENTS FOR INLET AIR SWIRL -----	18
4.	STEP INSERT FOR GASEOUS FACE INJECTION -----	18
5.	INJECTION RING FOR SIDE WALL INJECTION -----	19
6.	EXPERIMENTAL THRUST STAND AND SFFJ -----	19
7.	SCHEMATIC OF AIR AND GAS SUPPLY SYSTEM -----	20
8.	REGRESSION RATE VS SWIRL VANE ANGLE; HTPB FUEL -----	33
9.	REGRESSION RATE VS SWIRL VANE ANGLE; PMM FUEL -----	34
10.	PERCENT CHANGE IN CHAMBER PRESSURE; ACTUAL VS EQUILIBRIUM ADIABATIC COMBUSTION -----	35

TABLE OF SYMBOLS

A^*	nozzle throat area
a	air
C_d	discharge coefficient
d	diameter
\bar{D}_i	average initial port diameter
\bar{D}_f	average final port diameter
F	thrust
G	air mass flow per unit area in the fuel port
g_c	gravitational constant
H_2	hydrogen
i	inlet, initial
K_p	calibration constant
L	length of solid fuel grain
m	mass flow rate
NO	nitric oxide
N_2O	nitrous oxide
o	zero
O_2	oxygen
P	pressure
P_c	chamber pressure
P_t	stagnation pressure
R	gas constant
\dot{r}	fuel regression rate

T temperature
 T_t stagnation temperature
th theoretical
 t_b burn time
 V_p pressure transducer voltage
 ΔW weight change
 ϕ equivalence ratio
 $\eta_{\Delta t}$ temperature-rise combustion efficiency
 ρ density
 γ ratio of specific heats

ACKNOWLEDGEMENTS

I wish to acknowledge the guidance and patience of Professor David Netzer who greatly assisted me in the completion of this project. A special thanks to Mr. Glenn Middleton for his prompt and exceptional work and expert advice. I would also like to thank Mr. Don Harvey and Mr. Pat Hickey for their assistance and cooperation.

I. INTRODUCTION

With weapon systems becoming more advanced there is a need for a tactical missile propulsion system capable of providing longer missile ranges without increasing weight or volume. Currently the principal propulsion system used in tactical missiles is the solid propellant rocket. A solid fuel ramjet (SFRJ) can deliver higher fuel efficiency and specific impulse than a solid propellant rocket since it uses inlet air as a source of oxygen. The rocket must carry its own oxidizer, which adds weight and uses valuable fuel loading space. A relatively simple ramjet design consists of an air inlet, a combustor and an exhaust nozzle. The ramjet does not require a mechanical compressor, but supersonic speeds are required for effective compression of intake air. Various fuel grain designs are possible including addition of an integral boost grain to eliminate the need for a separate booster. Since the fuel is fully contained in the combustor there is no need for a separate fuel tank and associated delivery and control systems. Figure 1 illustrates the basic SFRJ.

A disadvantage of the SFRJ is its limited ability to meet varying operational envelopes of altitude and Mach number without significant combustor modifications. Although it has the capability to operate at high subsonic or low

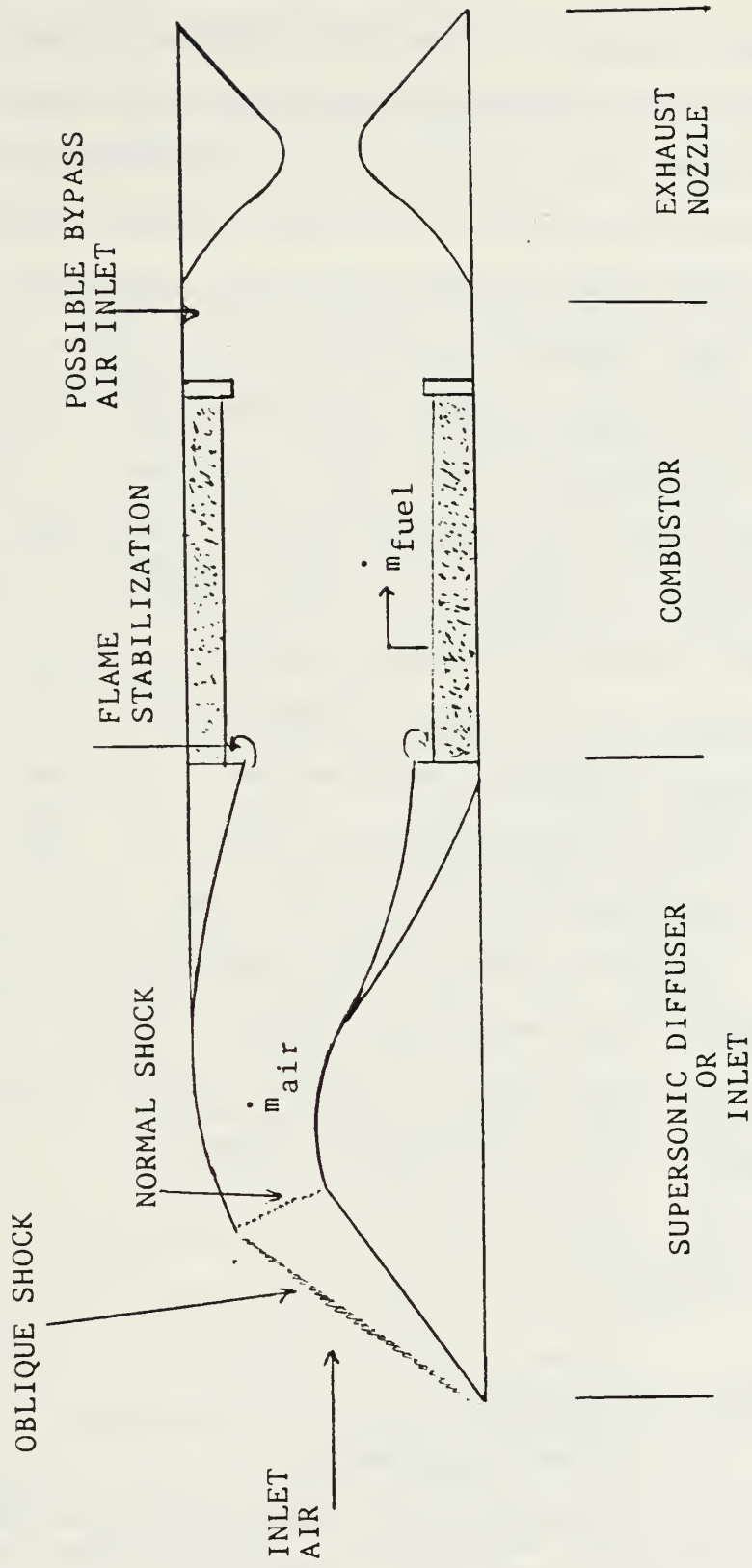

Figure 1. Schematic of Simple SFRJ.

supersonic speeds, increased diffuser and combustion performance are realized at high supersonic speeds. The SFRJ is therefore best suited for these higher Mach numbers.

Inside the combustor the gases near the surface of the fuel are fuel-rich and the gases near the center of the port are air-rich. Combustion efficiency can be increased by appropriately mixing these gases. One method used to promote mixing is the use of bypass air, where part of the inlet air is dumped into an aft mixing chamber. The bypass air enters the aft mixing chamber at high angles to the flow of combustion gases to facilitate mixing. Although combustion efficiency may be increased, undesired flow coupling could exist, causing pressure oscillations in the combustor/inlet.

The SFRJ is self-throttling since the fuel regression rate (\dot{r}) is dependent on the air mass flux through the engine. Although the SFRJ generally provides good performance, limited fuel control allows only small variations in altitude to maintain optimum fuel-air ratio. The relation for \dot{r} is generally given by

$$\dot{r} = a p_c^k T_i^m G^n$$

where a = constant

p_c = chamber pressure

G = mass flow per unit area in the fuel port

T_i = inlet air temperature

Typical values for the exponents are:

k : 0.1 - 0.3

m : 0.3 - 0.7

n : 0.3 - 0.6

Changes in \dot{r} can greatly influence the propulsive thrust and combustion efficiency of the SFRJ. As the air flow changes, so does \dot{r} , but to a lesser extent. Control of the air flow through the fuel port could be accomplished with the use of variable bypass, although the added complexity of such a system may not be desired. One alternative could be the use of variable inlet air swirl.

Campbell [Ref. 1] investigated the use of inlet air swirl on HTPB fuel as a means of controlling regression rate. He found that \dot{r} increased significantly for small amounts of swirl when the equivalence ratio was greater than unity, but larger amounts of swirl had less effect. With inlet swirl, the air flow through the port has an angular component, which may increase the residence time of the flow by increasing the effective length of the combustion section, and may increase fuel-air mixing. Thus, combustion efficiency may be increased with swirl but the thrust can be adversely effected by the loss in axial momentum.

Ko [Ref. 2] investigated the secondary injection of air, oxygen and gaseous fuel into the combustor as a possible means of thrust augmentation. He concluded that secondary

injection did not have a significant effect on \dot{r} , but injection of oxygen and gaseous fuel could have a strong influence on combustion pressure/thrust.

In the combustion process there may be unburned carbon in the form of soot exiting the fuel grain section. A gas rich in oxygen could be injected into the combustion process, enhancing the burning of this excess carbon. If the equivalence ratio is less than unity, there is excess oxygen in the motor. If a gaseous fuel is injected, it could burn with this excess oxygen. Both of these processes could increase combustion pressure and thrust. Such processes could be used to provide increased thrust at critical points in flight, such as at take-over from boost.

In this investigation two series of tests were conducted to help clarify earlier results. One series of tests was conducted to examine the effects of inlet swirl using PMM fuel at low G and HTPB fuel at low and high G. A second series was conducted to examine the effects of nitrous oxide and nitric oxide injection in the presence of soot and hydrogen injection in the presence of excess oxygen.

II. DESCRIPTION OF APPARATUS

A. RAMJET MOTOR

The ramjet motor used in this investigation has been used at the Naval Postgraduate School in earlier investigations [Refs. 1 and 2]. Figure 2 is a schematic of the SRFJ assembly. Inlet air from the plenum dumps is turned 90 degrees by a wedge in the head-end. There are radially oriented ports at the face of the inlet step for injection of ignition gas and the igniter torch. The step insert is interchangeable to allow different inlet configurations. A modified step inlet with a tube-in-hole injector [Ref. 1] was used for the swirl tests. Figure 3 shows the step insert and tubes used for the swirl tests. Another step insert shown in Figure 4, with injection ports on the step face [Ref. 2], was used for gas injection into the recirculation zone.

The fuel grain section consisted of either polymethylmethacrylate (PMM) or HTPB fuel. These grains were cylindrically perforated with various diameters and lengths. The fuel grain was held in place between the head-end and aft mixing chamber by threaded rods. Gas injection in the fuel grain section downstream of the recirculation zone was accomplished using a side wall injection ring [Ref. 2] as illustrated in Figure 5. The aft mixing chamber, which

consists of stainless steel sections, provided inlets for bypass air and gas injection and a chamber pressure tap. Photographs of the thrust stand and SFRJ assembly are shown in Figure 6.

B. AIR AND GAS SUPPLY AND CONTROL SYSTEM

Figure 7 is a schematic of the SFRJ air and gas supply system. The primary inlet air pressure was set using a remotely controlled dome loader with the air flow being controlled by a sonically choked nozzle. Methane was used in the vitiated air heater with make-up oxygen being injected downstream. Ethylene was used for the ignition gas and the purge gas was nitrogen. The tests were initiated from the control room using the Hewlett-Packard 9836S Computer and 3054A Data Acquisition/Control system to automatically sequence the solenoid-operated valves for primary air, ignition and purge gas. Ignition of the air heater and fuel grain were provided by ethylene/oxygen torches.

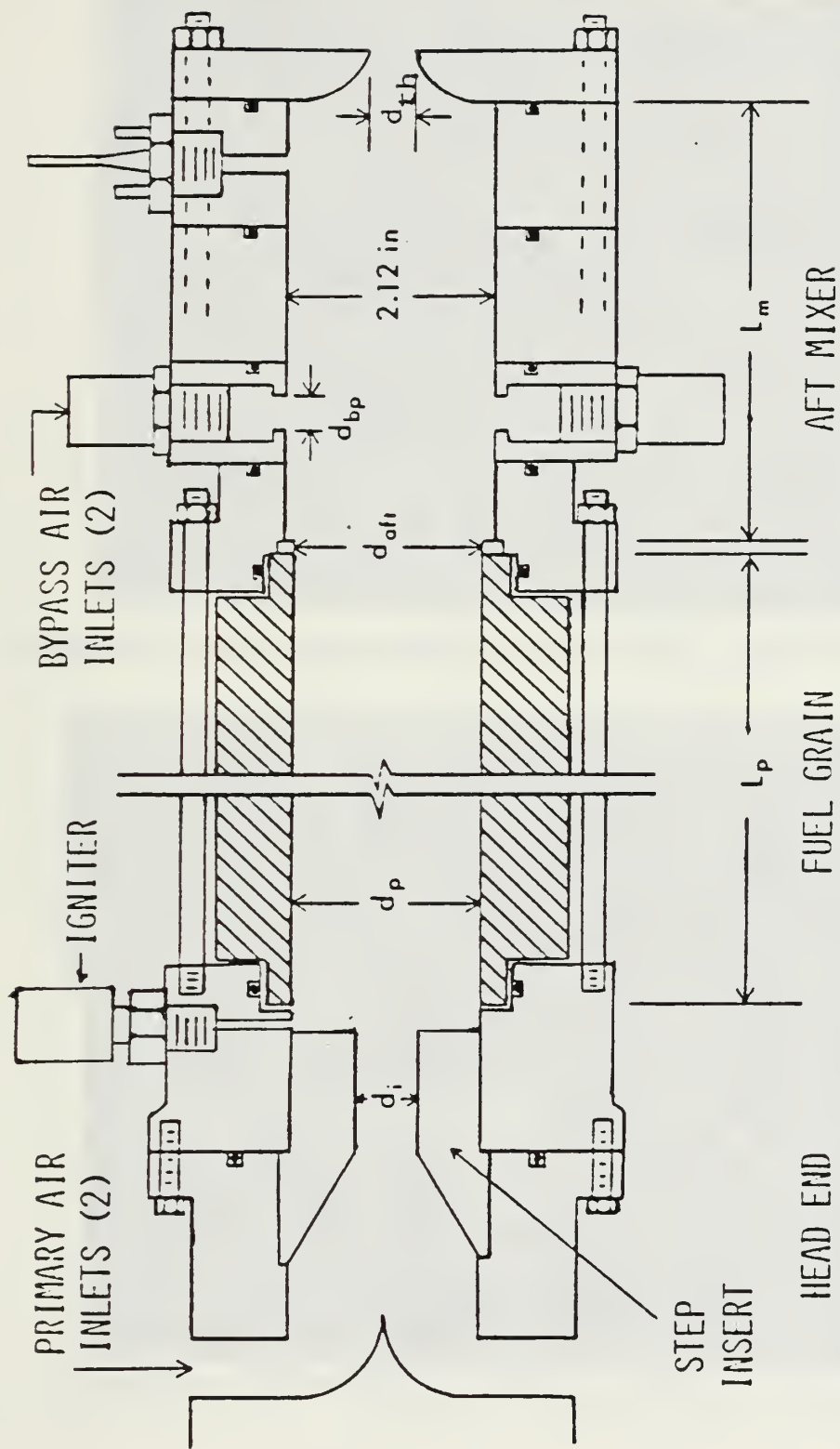

Figure 2. Schematic of Solid Fuel Ramjet Assembly.



Figure 3. Step Insert and elements for Inlet Air Swirl.

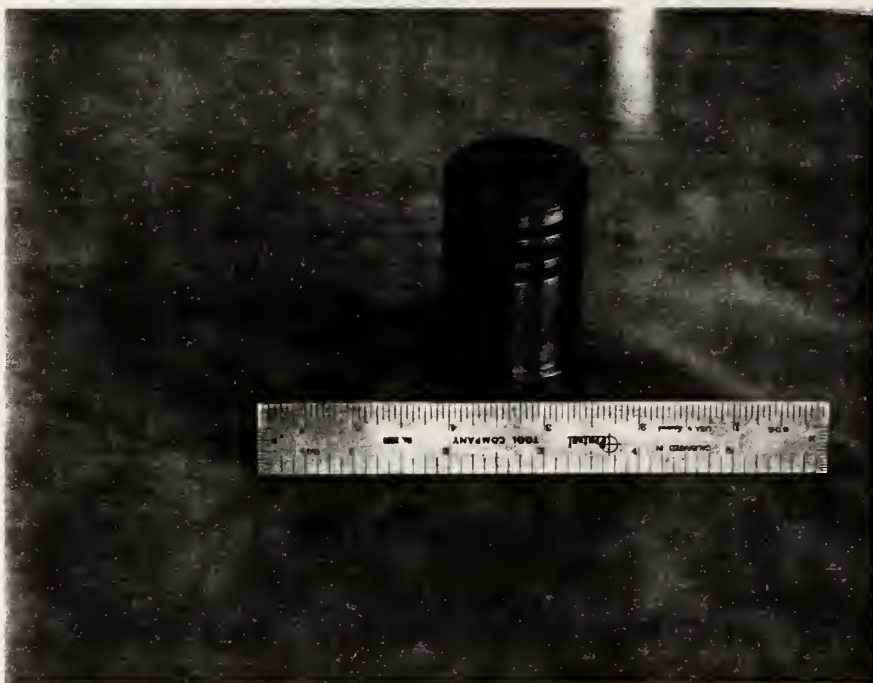

Figure 4. Step Insert for Gaseous Face Injection.

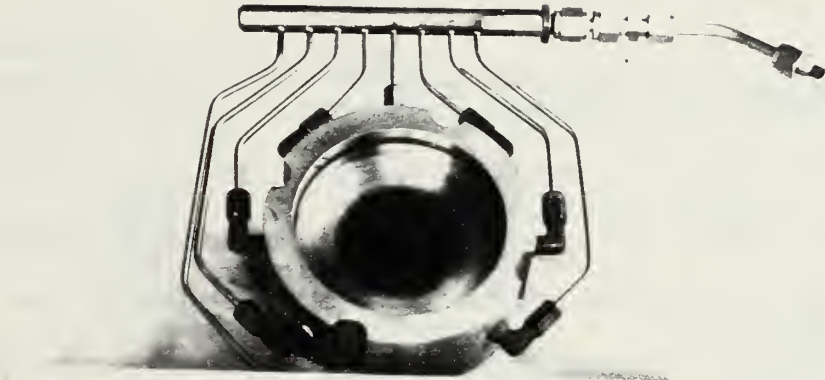

Figure 5. Injection Ring for Side Wall Injection.

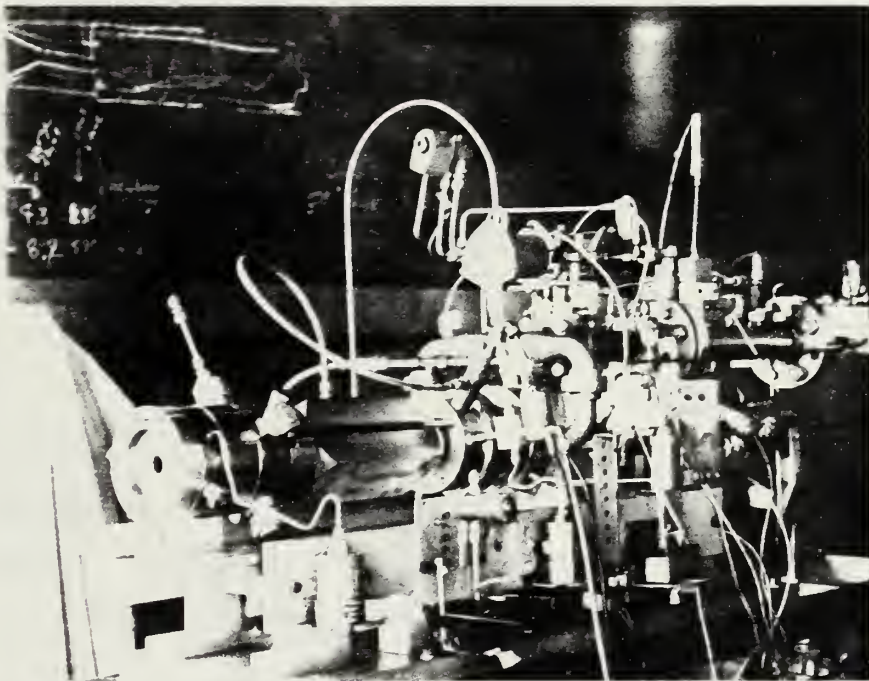

Figure 6. Experimental Thrust Stand and SFRJ.

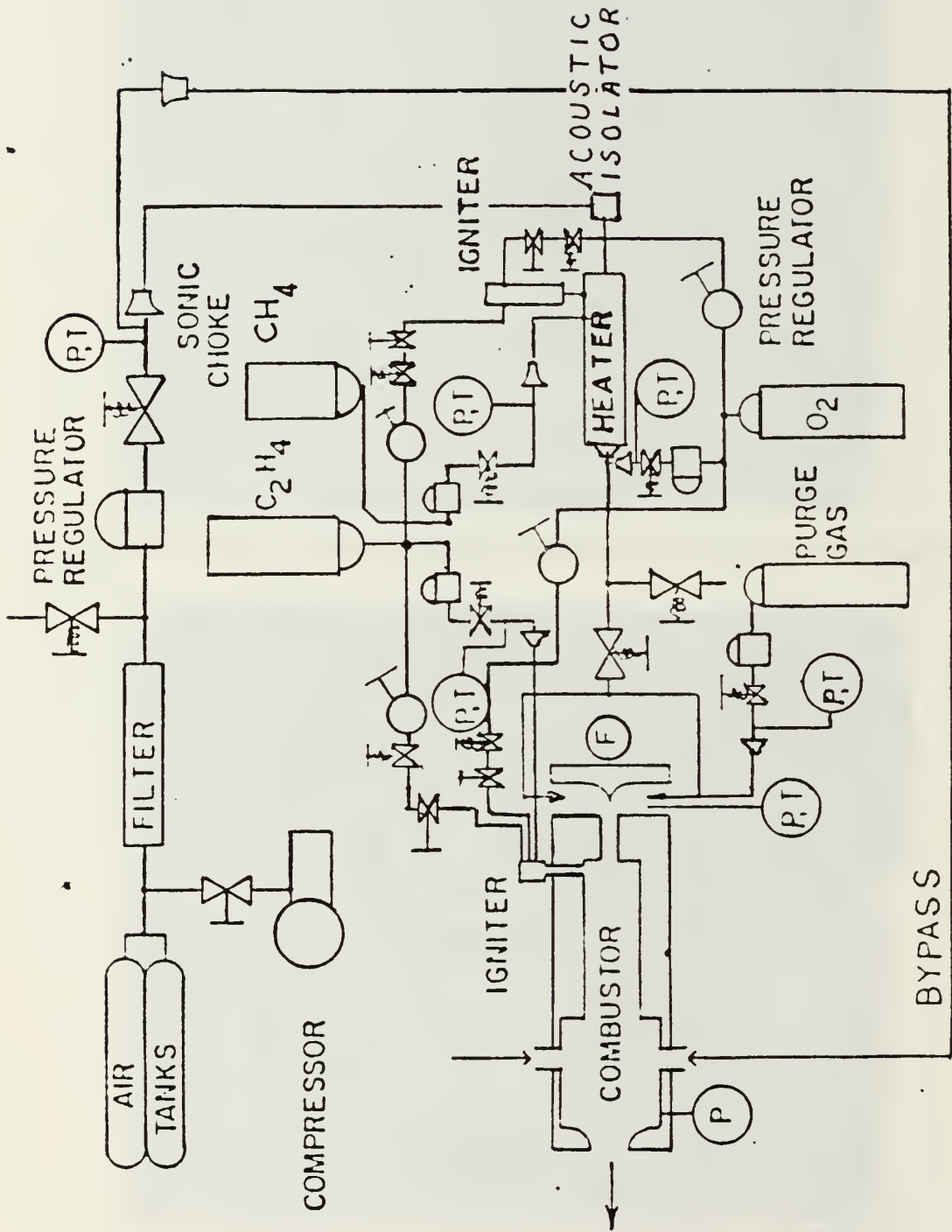

Figure 7. Schematic of Air and Gas Supply System

III. EXPERIMENTAL PROCEDURES

A. CALIBRATION

Prior to each days runs the pressure transducers were calibrated to the maximum expected operating pressure using a dead-weight tester. The thrust load cell was calibrated using a weight tray attached to the thrust stand with a cable/pulley. A calibration constant for each transducer (K_p), used in data acquisition during the runs, was determined by reading the voltage outputs from the transducer at atmospheric pressure and at maximum pressure. K_p was then calculated by

$$K_p = \frac{V_{p_{\max}} - V_{p_0}}{P_{\max}}$$

where $V_{p_{\max}}$ = voltage reading at maximum pressure

V_{p_0} = voltage reading at atmospheric pressure

P_{\max} = Maximum applied pressure

B. DATA EXTRACTION

A Honeywell 1508 Visicorder was used to record thrust (F), chamber pressure (P_c), primary air pressure (P_a), heater fuel pressure (P_{hf}), heater oxygen pressure (P_{ho}) and ignition gas pressure (P_{ig}) from the transducers. A Hewlett-Packard 9836S Computer and 3054A Automatic Data

Acquisition/Control System were also used to record and process all pressure, temperature and thrust digital data.

C. REACTING FLOW TESTS

The air flow was set by the remotely controlled dome loader for the primary air. The flow passed through a sonic choke with pressure and temperature being measured. The flow rate was calculated using the one dimensional continuity equation for a perfect gas.

$$\dot{m} = C_d P_t A^* \sqrt{\frac{g_c}{RT_t} \left(\frac{2}{\gamma+1} \right)^{\frac{\gamma+1}{\gamma-1}}}$$

where C_d is the discharge coefficient which was assumed to be 0.97.

The fuel grains were ignited by an oxygen/ethylene torch with ignition gas being injected into the recirculation zone. Each run was terminated by stopping the primary air flow through the motor and purging for three seconds with nitrogen.

Prior to each run the weight, internal diameter and length of the fuel grain were obtained. Upon completion of the run, the fuel grain was removed and weighed. The burn time, average chamber pressure and average thrust were obtained from the Visicorder trace. By subtracting the final weight from the initial weight, the mass of the fuel burned was determined. The average fuel mass flow rate was found by dividing the mass burned by the burn time.

The final average internal diameter of the fuel grain was calculated based on weight loss and length by using

$$\overline{D}_f = \sqrt{\frac{4\Delta W}{\pi\rho L} + \overline{D}_i^2}$$

The average fuel regression rate was then calculated using

$$\dot{r}_{\text{avg}} = \frac{\overline{D}_f - \overline{D}_i}{2t_b}$$

Average values of the mass flow rates for primary air, heater fuel, heater oxygen and ignition gas, along with the air inlet temperature were calculated from the digital output for the run.

The mass flow rates obtained for each run, along with inlet air temperature and chamber pressure were used as inputs into the Naval Weapons Center (NWC) China Lake, Ca., Propellant Evaluation Program (PEPCODE) to obtain the theoretical adiabatic combustion temperature and combustion gas properties (γ and R). The temperature-rise combustion efficiencies based on chamber pressure and thrust were calculated using these values. Ko [Ref. 2] gives a complete explanation of the procedures used in calculating the efficiencies.

For the series of tests using gas injection a remotely controlled solenoid valve was used to turn on and off the injection gas flow during the run. The changes in average chamber pressure and thrust were noted on the Visicorder,

corresponding with the addition of the injection gas. The expected change in pressure for equilibrium combustion was obtained by calculating values for the chamber pressure using the choked flow equation based on the total mass flow, throat area and the equilibrium combustion gas properties from PEPCODE (T_{th} , γ and R) for each run with and without the injection gas.

IV. RESULTS AND DISCUSSION

A. INLET AIR SWIRL

Tests were conducted using HTPB fuel with high G (0.5) and low G (0.25) and PMM fuel at low G (0.2). For the low G cases, a 0.92 inch diameter inlet with a tube-in-hole injector with either no vanes or swirl vane angles of 15 or 30 degrees was used (Fig. 3). For no swirl, a straight tube was used in which approximately 70 % of the airflow passed through the tube. Because of blockage by the blades, the air flow through the swirl elements dropped to approximately 56 % with 15 degrees vane angle and 46 % with 30 degrees vane angle. For the high G cases, a 1.125 inch diameter inlet with a tube-in-hole injector with either no vanes or swirl vane angles of 15 degrees was used. This larger inlet was necessary because of excessive blockage with the smaller inlet, resulting in the flow being choked through the inlet during the hot firing.

For this series of tests, the fuel grains were sized to give an equivalence ratio (ϕ) between approximately 0.6 and 0.8. Earlier tests conducted by Campbell [Ref. 1] were at equivalence ratios much greater than 1.0. Table 1 lists the physical characteristics of the fuel grains used in this investigation.

Measured quantities for each run are given in Tables 2 and 3. A plot of the regression rate vs swirl vane angle for HTPB fuel is given in Figure 8 together with the earlier results obtained by Campbell. A plot of the regression rate vs swirl vane angle for PMM fuel is given in Figure 9. The effects of swirl on regression rate seemed to be influenced by several factors, including length of the fuel grain, the ratio of inlet diameter to port diameter and the equivalence ratio.

For the HTPB fuels, the tests at low G were similar to those conducted by Campbell [Ref. 1]. The regression rate increased slightly with 15 degrees, but increasing the vane angle to 30 degrees had little additional effect. The tests conducted by Campbell showed more of an increase in regression rate. This difference could have been due to the higher equivalence ratio and longer grain lengths. This would indicate that the swirl effects on \dot{r} occur primarily at significant distances downstream of the reattachment point. The swirl had little effect on the combustion efficiency, possibly due to dissipation downstream. At high G there was also little effect on \dot{r} with 15 degrees of swirl, although only approximately 30 % of the air flow passed through the swirl element because of the larger inlet diameter.

For the PMM fuels the effects of swirl on \dot{r} varied with port diameter. With a 1.5 inch diameter port, the

regression rate actually decreased with 15 degrees swirl. When the port diameter was increased to 1.75 inches, \dot{r} increased slightly with 15 degrees swirl, and when increased to 2 inches there was a larger effect. There were no successful firings with 30 degrees swirl with PMM, probably due to the large inlet-to-port diameter ratio. As with the HTPB fuel, there was little effect on the combustion efficiency with swirl.

Since the different parameters for each run (T_i , G and P_c) were not constant for each firing, the regression rate was "corrected" to a base condition for comparison. For HTPB the relation for \dot{r} is given by

$$\dot{r} = k G^{.53} P^{.23} T^{.71} L^{.2}$$

Since there was a radial component of the inlet airflow, there was a loss in the axial momentum of the airflow. This could result in a decrease in thrust if the center flow is maintained at the swirl angle through the exhaust nozzle. For a 15 degree swirl angle using the 0.92 inch inlet, this would lead to approximately a 15 % drop in thrust and, therefore, a significant drop in combustion efficiency based on thrust. This drop did not occur, probably due to the swirl flow dissipating in the aft mixing chamber.

These results indicate that swirl can be used to increase the fuel regression rate for specific fuels with specific geometries and operating conditions. However, the

observed wide variation in the effects of swirl indicate that it will not be a simply applied method of regression rate control.

B. GASEOUS INJECTION

Tests were conducted with both PMM and HTPB fuels at various equivalence ratios. Table 4 presents a summary of the data for each hot firing. A plot of the measured increase in chamber pressure obtained with secondary gas injection, compared to the expected change in pressure for equilibrium adiabatic combustion is given in Figure 10. Also shown are some of the earlier results obtained by Ko [Ref. 2].

For H_2 injection there was a large increase in P_c and thrust, with the strongest effect occurring with head-end injection and $\phi \ll 1$. In order to verify the expected dependence on ϕ , one firing was conducted at $\phi > 1$, which resulted in little change in P_c . However, there was a visible increase in soot exiting from the motor, indicating the hydrogen was replacing the carbon in the combustion process.

N_2O and/or NO have received attention in liquid hydrocarbon combustion as possible enhancers/catalysts for soot combustion. For N_2O injection at the head-end and inlet step with PMM fuel, the increase in P_c was slightly higher than that expected from equilibrium combustion, indicating

some enhanced conversion of C/CO. However, this enhancement did not appear to vary with equivalence ratio and there was no evidence of enhancement with HTPB fuel. HTPB produces significantly more soot than PMM, indicating that enhanced soot consumption was not occurring to any major degree.

For NO injection with HTPB fuel, the increase in P_c was less than expected from equilibrium combustion, indicating no effect on the soot present. In fact, it may have been detrimental to combustion.

In summary, secondary injection of H_2 into the SFRJ results in the expected equilibrium-adiabatic increase in pressure/thrust. This could be a viable method for augmenting thrust of the SFRJ at critical points in the operating envelope (such as take-over from boost), allowing the motor design to be tailored to provide higher performance over the balance of the operating envelope. N_2O and NO did not appear to provide any significant enhancement for soot combustion.

TABLE 1

SWIRL TEST FUEL GRAIN PHYSICAL CHARACTERISTICS

Run #	Vane Angle (deg)	L_p (in)	D_p (in)	D_i (in)	D_{th} (in)	W_i (gm)
HTPB-1	0	7.531	1.753	0.920	0.943	397
HTPB-2	0	7.531	1.757	0.920	0.943	399
HTPB-3	15	7.480	1.756	0.920	0.943	396
HTPB-4	15	7.500	1.758	0.920	0.943	397
HTPB-5	15	6.880	1.756	0.920	0.943	362
HTPB-6	30	7.500	1.756	0.920	0.943	395
HTPB-7	30	6.720	1.758	0.920	0.943	353
HTPB-8	0	11.970	1.753	1.125	1.329	634
HTPB-9	15	11.938	1.760	1.125	1.329	633

PMM-1	0	11.875	1.505	0.920	0.735	2620
PMM-2	0	11.813	1.754	0.920	0.735	2672
PMM-3	0	11.875	2.000	0.920	0.943	2328
PMM-4	15	11.875	1.550	0.920	0.735	2714
PMM-5	15	11.938	1.754	0.920	0.735	2572
PMM-6	15	11.844	2.035	0.920	0.943	2339

TABLE 2

SWIRL TEST RESULTS--MASS FLOW RATES (LBM/SEC)

Run #	\dot{m}_{air}	\dot{m}_{fuel}	$\dot{m}_{htr_{O_2}}$	$\dot{m}_{htr_{CH_4}}$	\dot{m}_{if}	\dot{m}_{tot}
HTPB-1	0.582	0.0339	0.0234	0.0068	0.0039	0.646
HTPB-2	0.611	0.0356	0.0256	0.0074	0.0044	0.679
HTPB-3	0.605	0.0376	0.0370	0.0081	0.0035	0.688
HTPB-4	0.562	0.0373	0.0304	0.0072	0.0037	0.637
HTPB-5	0.590	0.0336	0.0284	0.0070	0.0038	0.659
HTPB-6	0.595	0.0379	0.0258	0.0079	0.0040	0.667
HTPB-7	0.633	0.0338	0.0253	0.0074	0.0044	0.700
HTPB-8	1.189	0.0629	0.0620	0.0146	0.0070	1.329
HTPB-9	1.231	0.0643	0.0417	0.0141	0.0090	1.351

PMM-1	0.357	0.0286	0.0158	0.0045	0.0026	0.406
PMM-2	0.467	0.0368	0.0246	0.0055	0.0035	0.534
PMM-3	0.627	0.0547	0.0311	0.0077	0.0040	0.721
PMM-4	0.351	0.0260	0.0158	0.0043	0.0025	0.397
PMM-5	0.470	0.0397	0.0265	0.0059	0.0036	0.542
PMM-6	0.642	0.0562	0.0322	0.0076	0.0041	0.738

TABLE 3

SWIRL TEST RESULTS--COMBUSTION PROPERTIES

Run #	γ	R ($\frac{ft-lbf}{lbm-\circ R}$)	T _i (°R)	\bar{P}_c (psia)	\bar{P}_{air} (psia)	\bar{F} (lbf)	\bar{F}_{air} (lbf)
HTPB-1	1.2526	53.15	1124	117	59	88	39
HTPB-2	1.2524	53.16	1107	123	62	91	38
HTPB-3	1.2496	53.12	1136	128	62	95	39
HTPB-4	1.2471	53.17	1151	123	60	89	36
HTPB-5	1.2537	53.14	1126	122	62	91	39
HTPB-6	1.2482	53.24	1149	121	61	89	35
HTPB-7	1.2567	52.99	1104	125	64	93	39
HTPB-8	1.2567	53.14	1187	107	57	166	78
HTPB-9	1.2572	53.19	1158	110	59	169	76

PMM-1	1.2585	53.17	1019	102	51	49	20
PMM-2	1.2599	53.08	1032	138	69	68	29
PMM-3	1.2534	53.10	1165	125	63	95	44
PMM-4	1.2649	53.17	991	97	48	45	19
PMM-5	1.2560	53.07	1045	143	69	71	28
PMM-6	1.2534	53.07	1178	133	60	101	46

Run #	\dot{r} (in/sec)	ϕ	T _{t_{th}} (°R)	$\eta_{\Delta T_{P_c}}$ (%)	$\eta_{\Delta T_F}$ (%)
HTPB-1	0.0226	0.751	3954	98.5	97.7
HTPB-2	0.0235	0.754	3940	94.7	89.0
HTPB-3	0.0249	0.788	4045	98.3	94.7
HTPB-4	0.0245	0.847	4197	102.8	94.9
HTPB-5	0.0241	0.730	3892	104.2	101.7
HTPB-6	0.0251	0.821	4129	90.5	85.0
HTPB-7	0.0250	0.691	3758	92.7	95.1
HTPB-8	0.0258	0.677	3768	89.5	83.9
HTPB-9	0.0267	0.681	3768	93.3	83.8

PMM-1	0.0099	0.632	3467	99.1	85.0
PMM-2	0.0113	0.617	3437	96.7	92.0
PMM-3	0.0142	0.685	3725	94.2	93.5
PMM-4	0.0089	0.583	3187	91.1	86.0
PMM-5	0.0118	0.659	3571	96.9	93.9
PMM-6	0.0151	0.687	3740	101.0	102.0

TABLE 4

SUMMARY OF GASEOUS INJECTION TESTS

Run #	\dot{m} air (lbm/sec)	\dot{m} inj (lbm/sec)	ϕ	Injection location	$\frac{\Delta P_c}{P_c}$ (%)	$\frac{\Delta P_c}{P_c}$ equal (%)

7.5 % N ₂ O Injection						
PMM-7	0.270	0.0212	1.010	inlet step	11.3	5.0
PMM-8	0.274	0.0212	0.959	6" past step	8.9	6.6
PMM-9	0.345	0.0275	1.140	head end	14.9	10.0
PMM-10	0.365	0.0275	1.144	aft mix	10.4	10.0
PMM-11	0.362	0.0275	0.720	head end	9.1	6.3

HTPB-10	0.368	0.0275	1.796	head end	12.7	12.0
HTPB-11	0.367	0.0275	1.806	aft mix	12.5	12.0

5 % NO Injection						

HTPB-12	0.341	0.0177	1.590	head end	8.0	10.3
HTPB-13	0.353	0.0177	1.540	aft mix	6.0	10.3

2 % H ₂ Injection						

PMM-12	0.279	0.005	0.481	inlet step	31.6	36.0
PMM-13	0.365	0.007	0.769	head end	16.0	11.5
PMM-14	0.358	0.007	0.783	aft mix	10.5	11.5
PMM-15	0.362	0.007	1.290	head end	3.6	0

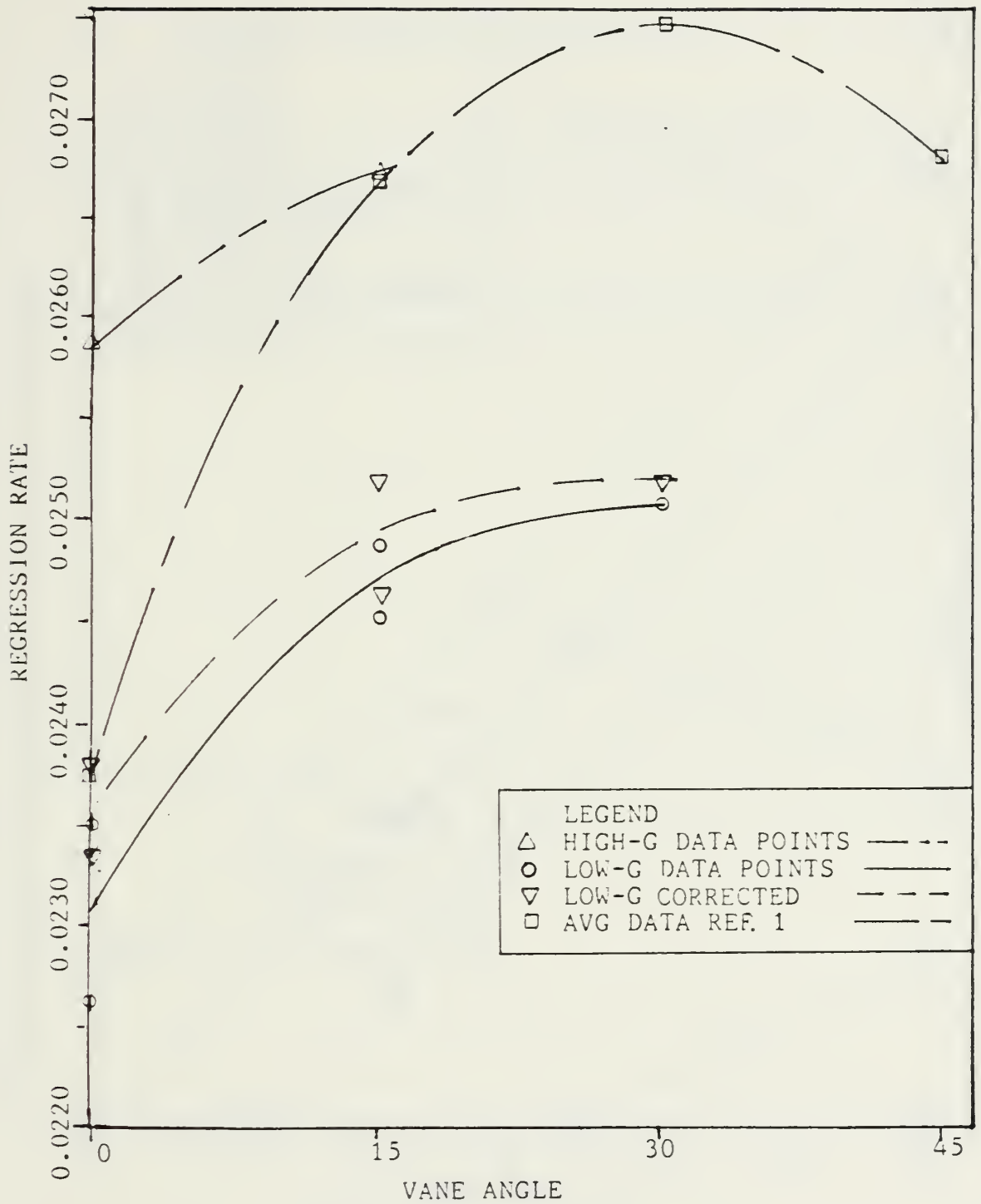

Figure 8. Regression Rate vs Swirl Vane Angle; HTPB Fuel.

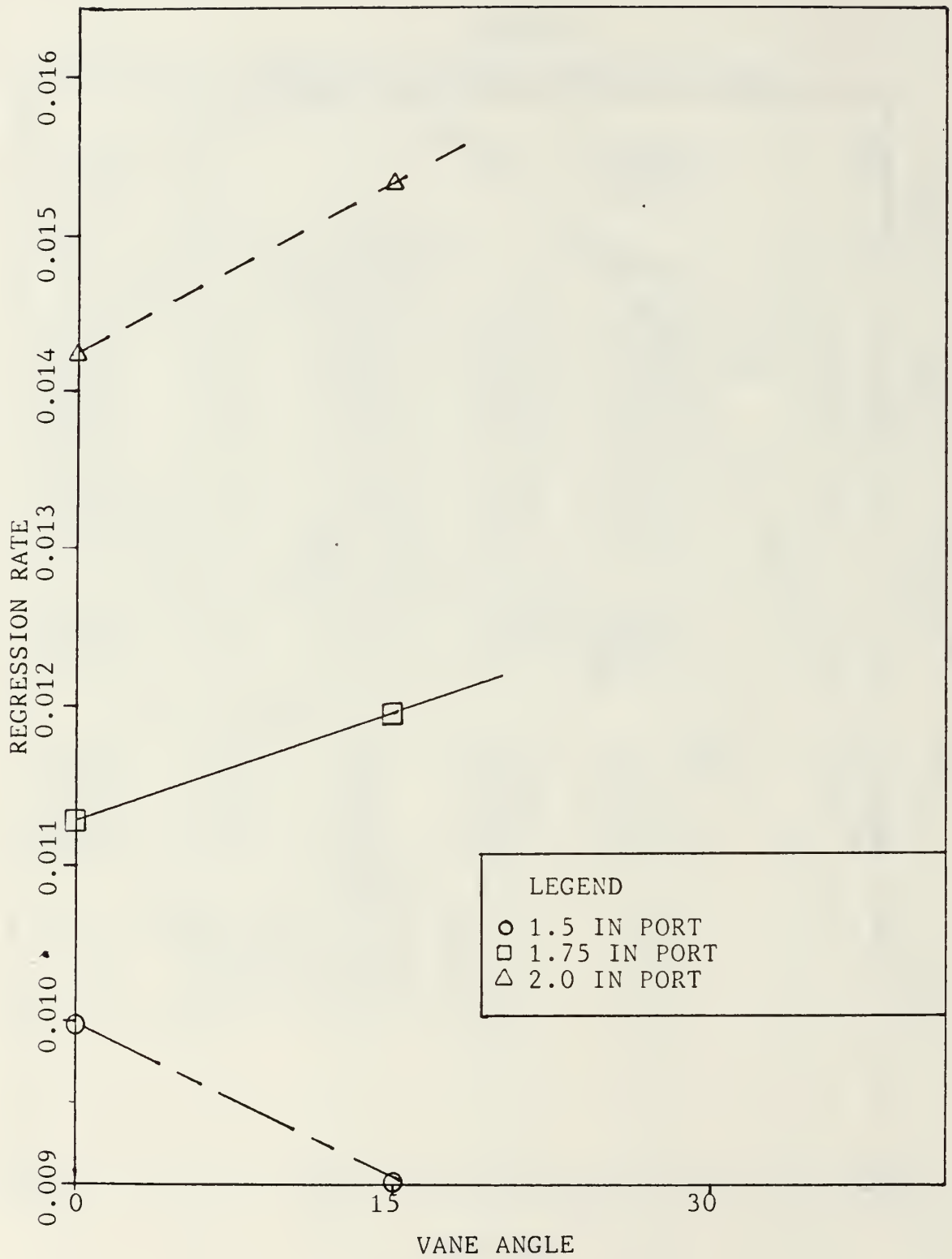

Figure 9. Regression Rate vs Swirl Vane Angle; PMM Fuel.

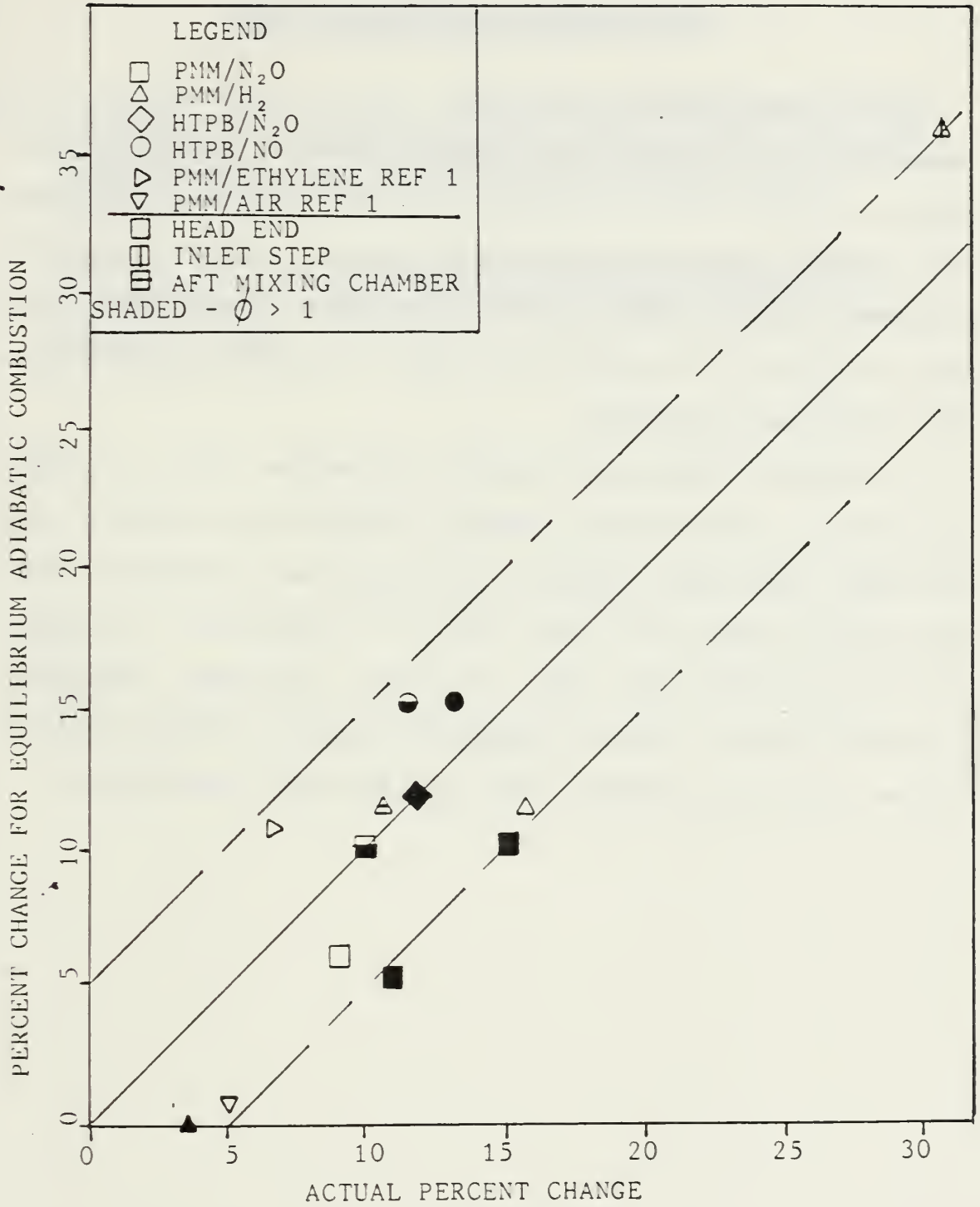

Figure 10. Percent Change in Chamber Pressure; Actual vs Equilibrium Adiabatic Combustion.

V. CONCLUSIONS AND RECOMMENDATIONS

This investigation verified that regression rate generally does increase with inlet air swirl, although the extent of the increase appears to be dependent on the equivalence ratio, grain length and inlet diameter to port diameter ratio. It is therefore concluded that inlet air swirl could only be used effectively for specific geometries and operating conditions.

In general, the use of gaseous injection led to small increases in combustion pressure with the exception of hydrogen. When small amounts of hydrogen were injected with equivalence ratios less than unity, a substantial increase in pressure and thrust were realized. Hydrogen injection could be used for thrust augmentation during critical points in the operating envelope (such as take-over from boost).

LIST OF REFERENCES

1. Campbell, William H. Jr., An Experimental Investigation of the Effects of Swirling Air Flows on the Combustion Properties of a Solid Fuel Ramjet Motor, M. S. Thesis, Naval Postgraduate School, Monterey, California, December, 1985.
2. Ko, Bog Nam, An Experimental Investigation of Fuel Regression Rate Control in Solid Fuel Ramjets, M. S. Thesis, Naval Postgraduate School, Monterey California, December 1984.

INITIAL DISTRIBUTION LIST

	No. Copies
1. Defense Technical Information Center Cameron Station Alexandria, Virginia 22304-6145	2
2. Superintendent Attn: Library, Code 0142 Naval Postgraduate School Monterey, California 93943-5000	2
3. Department Chairman, Code 67 Department Of Aeronautics Naval Postgraduate School Monterey, California 93943-5000	1
4. Professor D. W. Netzer, Code 67Nt Department Of Aeronautics Naval Postgraduate School Monterey, California 93943-5000	2
5. Lt. Stephen R. Lowe Naval Ordnance Missile Test Station White Sands Missile Range, New Mexico 88002-5510	2

218801

Thesis

L8577 Lowe

c.1

An experimental investigation of combustion modulation techniques for a solid fuel ramjet.

218801

Thesis

L8577 Lowe

c.1

An experimental investigation of combustion modulation techniques for a solid fuel ramjet.

thesL8577

An experimental investigation of combust



3 2768 000 67107 7

DUDLEY KNOX LIBRARY