



**Calhoun: The NPS Institutional Archive**  
**DSpace Repository**

---

Theses and Dissertations

1. Thesis and Dissertation Collection, all items

---

2008-12

# Combating the military's escalating pharmacy costs: a lean Six Sigma approach

Nuce, James; Sikora, Tom; Robinson, Lydia

Monterey, California. Naval Postgraduate School

---

<https://hdl.handle.net/10945/10316>

---

This publication is a work of the U.S. Government as defined in Title 17, United States Code, Section 101. As such, it is in the public domain, and under the provisions of Title 17, United States Code, Section 105, is not copyrighted in the U.S.

*Downloaded from NPS Archive: Calhoun*



Calhoun is the Naval Postgraduate School's public access digital repository for research materials and institutional publications created by the NPS community. Calhoun is named for Professor of Mathematics Guy K. Calhoun, NPS's first appointed -- and published -- scholarly author.

**Dudley Knox Library / Naval Postgraduate School**  
**411 Dyer Road / 1 University Circle**  
**Monterey, California USA 93943**

<http://www.nps.edu/library>



**NAVAL  
POSTGRADUATE  
SCHOOL**

**MONTEREY, CALIFORNIA**

---

**MBA PROFESSIONAL REPORT**

---

**Combating the Military's Escalating Pharmacy Costs:  
A Lean Six Sigma Approach**

---

**By: James Nuce,  
Lydia Robinson, and  
Tom Sikora  
December 2008**

**Advisors: Keebom Kang,  
Uday Apte,  
Susan Heath**

*Approved for public release; distribution is unlimited.*

THIS PAGE INTENTIONALLY LEFT BLANK

<b>REPORT DOCUMENTATION PAGE</b>			Form Approved OMB No. 0704-0188	
Public reporting burden for this collection of information is estimated to average 1 hour per response, including the time for reviewing instruction, searching existing data sources, gathering and maintaining the data needed, and completing and reviewing the collection of information. Send comments regarding this burden estimate or any other aspect of this collection of information, including suggestions for reducing this burden, to Washington headquarters Services, Directorate for Information Operations and Reports, 1215 Jefferson Davis Highway, Suite 1204, Arlington, VA 22202-4302, and to the Office of Management and Budget, Paperwork Reduction Project (0704-0188) Washington DC 20503.				
<b>1. AGENCY USE ONLY (Leave blank)</b>		<b>2. REPORT DATE</b> December 2008	<b>3. REPORT TYPE AND DATES COVERED</b> MBA Professional Report	
<b>4. TITLE AND SUBTITLE:</b> Combating the Military's Escalating Pharmacy Costs: A Lean Six Sigma Approach			<b>5. FUNDING NUMBERS</b>	
<b>6. AUTHOR(S)</b> James Nuce, Lydia Robinson, and Tom Sikora				
<b>7. PERFORMING ORGANIZATION NAME(S) AND ADDRESS(ES)</b> Naval Postgraduate School Monterey, CA 93943-5000			<b>8. PERFORMING ORGANIZATION REPORT NUMBER</b>	
<b>9. SPONSORING / MONITORING AGENCY NAME(S) AND ADDRESS(ES)</b> N1 – Naval Manpower			<b>10. SPONSORING / MONITORING AGENCY REPORT NUMBER</b>	
<b>11. SUPPLEMENTARY NOTES</b> The views expressed in this report are those of the author(s) and do not reflect the official policy or position of the Department of Defense or the U.S. Government.				
<b>12a. DISTRIBUTION / AVAILABILITY STATEMENT</b> Approved for public release; distribution is unlimited.			<b>12b. DISTRIBUTION CODE</b>	
<b>13. ABSTRACT</b>  The pharmacy operations of three military, Medical Treatment Facilities (MTF) were observed, to determine possible process improvements and cost saving mechanisms that may be achieved through Lean Six Sigma methodologies. After mapping the processes of each facility (one large, one medium, and one small) each was modeled and validated in order to forecast potential savings, increases in efficiency, and/or waste reduction while either maintaining or improving customer satisfaction (i.e., processing times). The research proved that Lean Six Sigma methodologies can be implemented within pharmacy operations, often at little or zero cost, while realizing significant savings and increased customer satisfaction.				
<b>14. SUBJECT TERMS</b> Lean six sigma, Pharmacy, Pharmacy operations, Military treatment facilities, Military healthcare, Discrete-event Simulation			<b>15. NUMBER OF PAGES</b> 143	
			<b>16. PRICE CODE</b>	
<b>17. SECURITY CLASSIFICATION OF REPORT</b> Unclassified	<b>18. SECURITY CLASSIFICATION OF THIS PAGE</b> Unclassified	<b>19. SECURITY CLASSIFICATION OF ABSTRACT</b> Unclassified	<b>20. LIMITATION OF ABSTRACT</b> UU	

THIS PAGE INTENTIONALLY LEFT BLANK

**Approved for public release; distribution is unlimited.**

**COMBATING THE MILITARY'S ESCALATING PHARMACY COSTS:  
A LEAN SIX SIGMA APPROACH**

James Nuce  
Captain, United States Army  
B.A., University of West Florida, 1999

Lydia Robinson  
Lieutenant, MSC, United States Navy  
B.S., University of Maryland, 1999

Tom Sikora  
Captain, United States Marine Corps  
B.A., The Citadel, 2001

Submitted in partial fulfillment of the  
requirements of the degree of

**MASTER OF BUSINESS ADMINISTRATION**

from the

**NAVAL POSTGRADUATE SCHOOL  
December 2008**

Authors:

---

James Nuce

---

Lydia Robinson

---

Tom Sikora

Approved by:

---

Susan Heath, Support Advisor

---

Uday Apte, Lead Advisor

---

Keebom Kang, Support Advisor

---

Theresa Rea, CAPT, USN, Acting Dean  
Graduate School of Business and Public Policy

THIS PAGE INTENTIONALLY LEFT BLANK

# **COMBATING THE MILITARY'S ESCALATING PHARMACY COSTS: A LEAN SIX SIGMA APPROACH**

## **ABSTRACT**

The pharmacy operations of three military Medical Treatment Facilities (MTF) were observed to determine possible process improvements and cost saving mechanisms that may be achieved through Lean Six Sigma methodologies. After mapping the processes of each facility (one large, one medium, and one small), each was modeled using discrete-event simulation in order to forecast potential savings, increases in efficiency, and/or waste reduction while either maintaining or improving customer satisfaction (i.e., wait times). The research proved that Lean Six Sigma business practices could be implemented within military pharmacy operations, often at little or zero cost, while realizing significant savings and increased customer satisfaction.



THIS PAGE INTENTIONALLY LEFT BLANK

# TABLE OF CONTENTS

<b>EXECUTIVE SUMMARY .....</b>	<b>1</b>
<b>I. INTRODUCTION.....</b>	<b>3</b>
<b>II. LITERATURE REVIEW OF LEAN SIX SIGMA APPLICATIONS .....</b>	<b>5</b>
<b>A. LEAN SIX SIGMA .....</b>	<b>5</b>
<b>B. APPLICATIONS FOR COST REDUCTIONS IN MANPOWER .....</b>	<b>6</b>
<b>C. APPLICATIONS FOR FACILITY REDUCTIONS.....</b>	<b>10</b>
<b>D. APPLICATIONS FOR DISPENSING PRACTICES .....</b>	<b>11</b>
<b>III. COST OF THE PHARMACY .....</b>	<b>15</b>
<b>A. PHARMACY COSTS.....</b>	<b>15</b>
1. Manpower Costs.....	18
2. Dispensing Costs .....	19
<b>B. CONGRESSIONAL LEGISLATION .....</b>	<b>20</b>
1. TRICARE for Life .....	21
2. Cost-sharing Initiatives .....	21
3. Reserve Benefits .....	22
4. New Legislation for Pharmaceuticals.....	22
<b>IV. IMPROVING PHARMACY OPERATIONS USING LEAN SIX SIGMA .....</b>	<b>23</b>
<b>A. METHODOLOGY .....</b>	<b>24</b>
<b>B. DEFINE THE PHARMACY CUSTOMER.....</b>	<b>25</b>
1. Project Charter .....	25
2. The Core Business Process Involved in Operations (SIPOC).....	26
3. The Critical to Quality (CTQ) Issues Involved in Operations.....	27
<b>V. DLI PHARMACY.....</b>	<b>29</b>
<b>A. VOICE OF THE CUSTOMER (VOC).....</b>	<b>29</b>
<b>B. PROCESS FLOW MAP.....</b>	<b>31</b>
<b>C. DATA COLLECTION AND ANALYSIS .....</b>	<b>32</b>
1. The Fishbone Diagram Analysis.....	33
2. Collect Data for Determining Defects and Metrics.....	36
<b>D. SIMULATION ANALYSIS .....</b>	<b>40</b>
1. Arena Simulation Model Information and Flow .....	40
2. Simulation Entities.....	44
3. Simulation Resources.....	45
4. Simulation Processes.....	45
5. Experiment Description.....	46
6. Results Analysis.....	48
7. Conclusions and Recommendations.....	50
<b>VI. TRAVIS AFB PHARMACIES .....</b>	<b>53</b>
<b>A. VOICE OF THE CUSTOMER .....</b>	<b>54</b>
<b>B. PROCESS FLOW MAP.....</b>	<b>56</b>

1.	The Travis Air Force Base Hospital Pharmacy .....	56
2.	The Travis Air Force Base PX Annex Pharmacy .....	58
3.	Travis Air Force Base Annex Pharmacy (Re-fill Operations).....	60
C.	DATA COLLECTION AND ANALYSIS .....	61
1.	The Fishbone Diagram .....	61
2.	Collect Data for Determining Defects and Metrics.....	61
a.	<i>Main Pharmacy</i> .....	62
b.	<i>Annex Pharmacy</i> .....	69
c.	<i>Refill Pharmacy</i> .....	72
D.	SIMULATION ANALYSIS .....	76
1.	Travis AFB Main Pharmacy.....	76
a.	<i>Arena Simulation Model Information and Flow</i> .....	76
b.	<i>Simulation Entities</i> .....	77
c.	<i>Simulation Resources</i> .....	77
d.	<i>Simulation Processes</i> .....	78
e.	<i>Simulation Results</i> .....	78
2.	Travis AFB Base Exchange Annex Pharmacy .....	80
a.	<i>Arena Simulation Model Information and Flow</i> .....	80
b.	<i>Simulation Resources</i> .....	81
c.	<i>Simulation Processes</i> .....	81
3.	Results Analysis.....	83
a.	<i>Travis Air Force Base Main Pharmacy</i> .....	83
b.	<i>Travis Air Force Base Annex Pharmacy</i> .....	84
c.	<i>Travis Air Force Base Refill Pharmacy</i> .....	85
E.	CONCLUSIONS AND RECOMMENDATIONS.....	86
1.	The Travis AFB Main Pharmacy .....	87
2.	The Travis AFB Annex Pharmacy .....	88
VII.	SAN DIEGO NAVAL BASE PHARMACY (BALBOA) .....	91
A.	VOICE OF THE CUSTOMER .....	92
B.	PROCESS FLOW MAP.....	92
C.	DATA COLLECTION AND ANALYSIS .....	94
1.	The Fishbone Diagram Analysis.....	95
2.	Collect Data for Determining Defects and Metrics.....	95
D.	SIMULATION ANALYSIS .....	100
1.	Arena Simulation Model Information and Flow .....	100
2.	Simulation Resources.....	102
3.	Simulation Processes.....	102
4.	Opportunities for Improvement .....	103
E.	CONCLUSIONS AND RECOMMENDATIONS.....	104
VIII.	CONCLUSIONS AND RECOMMENDATIONS FOR FURTHER STUDY ...	107
A.	SUMMARY .....	107
B.	CONCLUSIONS .....	107
C.	RECOMMENDATIONS.....	109
D.	SUGGESTIONS FOR FURTHER STUDY .....	111

<b>LIST OF REFERENCES .....</b>	<b>115</b>
<b>APPENDIX A .....</b>	<b>119</b>
<b>APPENDIX B .....</b>	<b>121</b>
<b>INITIAL DISTRIBUTION LIST .....</b>	<b>123</b>

THIS PAGE INTENTIONALLY LEFT BLANK

## LIST OF FIGURES

Figure 1.	Past and Projected Resources for Operations and Support.....	16
Figure 2.	Past and Projected Resources for the Military Medical System.....	17
Figure 3.	SIPOC Process Diagram.....	26
Figure 4.	DLI Process Flow Map.....	31
Figure 5.	DLI Fishbone Diagram for Excessive Costs.....	34
Figure 6.	DLI Fishbone Diagram for Processing Time.....	35
Figure 7.	DLI Prime Vendor Expenditures for FY 2008.....	38
Figure 8.	DLI Credit Card Expenditures for FY 2008.....	39
Figure 9.	DLI Simulation: Drug arrivals and initial inventory.....	41
Figure 10.	DLI Simulation: Patient arrivals.....	42
Figure 11.	DLI Simulation: Initial patient and order processing.....	42
Figure 12.	DLI Simulation: Physical filling of prescriptions.....	43
Figure 13.	DLI Simulation: Matching of patient and filled prescription.....	43
Figure 14.	Travis AFB Main Pharmacy Process Flow Map.....	56
Figure 15.	Travis AFB Annex Pharmacy Process Flow Map.....	58
Figure 16.	Travis AFB Call-in Process Flow Map.....	60
Figure 17.	Travis AFB Main Pharmacy Patient Wait times by Month.....	63
Figure 18.	Travis AFB Main Pharmacy – Possible Work Reductions.....	64
Figure 19.	Travis AFB Prime Vendor Expenditures for FY 2008.....	66
Figure 20.	Travis AFB Credit Card Expenditure for FY 2008.....	66
Figure 21.	Travis AFB Annex Patient Processing times by Month.....	70
Figure 22.	Travis AFB Annex – Possible Work Reductions.....	71
Figure 23.	Balboa Naval Hospital Pharmacy Process Flow Map.....	92
Figure 24.	Balboa – Monthly Patient Processing Times.....	98
Figure 25.	Balboa – Monthly Patient Processing Times without Q-flow.....	99

THIS PAGE INTENTIONALLY LEFT BLANK

## LIST OF TABLES

Table 1.	Pay Comparison for GS and military pharmacy employees.....	18
Table 2.	DLI Pharmacy Patient Survey .....	30
Table 3.	DLI Patient Volume Report .....	37
Table 4.	DLI Total Pharmaceutical Expenditures for FY 2008.....	39
Table 5.	DLI Process Analyzer Model Results.....	47
Table 6.	DLI (with Script Call-in) Process Analyzer Model Results .....	48
Table 7.	Travis AFB Main Pharmacy Patient Survey.....	54
Table 8.	Travis AFB Annex Pharmacy Patient Survey .....	55
Table 9.	Travis AFB Main Pharmacy Patient Volume Report .....	62
Table 10.	Travis AFB Main Pharmacy Patient Wait times.....	63
Table 11.	Travis AFB Main Pharmacy – Possible Work Reductions.....	64
Table 12.	Travis AFB Main Pharmacy – Total Expenditures for FY 2008.....	67
Table 13.	Travis AFB Main Pharmacy – Employee Pay Table.....	68
Table 14.	Travis AFB Annex Patient Volume Report .....	69
Table 15.	Travis AFB Annex Patient Processing Times .....	70
Table 16.	Travis AFB Annex – Employee Pay Table.....	72
Table 17.	Travis AFB Refill Pharmacy – Personnel Pay Chart.....	74
Table 18.	Travis AFB Pharmaceutical Stocked Line-items.....	74
Table 19.	Travis AFB Pharmaceutical Stocked Line-item Consolidation.....	75
Table 20.	Travis Main Pharmacy Process Analyzer Results .....	79
Table 21.	Travis Annex Process Analyzer Results .....	82
Table 22.	Travis Annex Process Analyzer Results (Script Only).....	83
Table 23.	Balboa Medical Center Patient Volume Report.....	96
Table 24.	Balboa Medical Center Patient Wait times .....	97
Table 25.	Balboa Medical Center Total Expenditures for FY 08 .....	99
Table 26.	Balboa Process Analyzer Results.....	104



THIS PAGE INTENTIONALLY LEFT BLANK

## LIST OF ACRONYMS AND ABBREVIATIONS

AFB	AIR FORCE BASE
CBO	CONGRESSIONAL BUDGET OFFICE
CHCS	COMPOSITE HEALTH CARE SYSTEM
CMOP	CONSOLIDATED MAIL ORDER PHARMACY
CTQ	CRITICAL TO QUALITY
DLA	DEFENSE LOGISTICS AGENCY
DLI	DEFENSE LANGUAGE INSTITUTE
DMAIC	DEFINE, MEASURE, ANALYZE, IMPROVE, CONTROL
DoD	DEPARTMENT OF DEFENSE
FSS	FEDERAL SUPPLY SYSTEM
GS	GOVERNMENT
LSS	LEAN SIX SIGMA
MAR	MEDICATION ADMINISTRATION RECORDS
MBA	MASTERS OF BUSINESS ADMINISTRATION
MTF	MEDICAL TREATMENT FACILITY
O&S	OPERATIONS AND SUPPORT
OE	ORDER ENTRY
OMB	OFFICE OF MANAGEMENT AND BUDGETING
OPM	OFFICE OF THE PERSONNEL MANAGEMENT
OR	OPERATING ROOM
PDTS	PATIENT DATA TRANSACTION SYSTEM
POE	PROVIDER ORDER ENTRY
PTO	PHARMACY TYPE ORDER
RX	PHARMACEUTICAL PRESCRIPTION
SIPOC	SUPPLIES, INPUTS, PROCESS, OUTPUT, CUSTOMER
TFL	TRICARE FOR LIFE
TMOP	TRICARE MAIL ORDER PHARMACY PROGRAM
TRICARE	TRI-SERVICE HEALTHCARE SYSTEM

THIS PAGE INTENTIONALLY LEFT BLANK

## **ACKNOWLEDGMENTS**

We would like to personally thank our families, Professors Kang, Apte, and Heath; and the staff of each of the facilities that we visited. Without their help, the successful accomplishment of this MBA Project would not have been possible.

THIS PAGE INTENTIONALLY LEFT BLANK

## **EXECUTIVE SUMMARY**

Healthcare costs throughout the United States are on the rise, drawing increased scrutiny from government officials and Congress. The Department of Defense (DoD) is not immune to the increasing costs or the increasing scrutiny, as health care for service members, their dependents, and military and government retirees comprise the largest percentage of defense spending. In addition, as the number of retirees increases, and the DoD remains engaged in two wars, increases in health care expenses become even more pronounced. The cost of pharmacy operations and pharmaceuticals is growing at a rate higher than that of the total cost of military healthcare itself. As in the civilian sector, pharmaceutical costs are growing at an alarming rate.

Recent congressional legislation has essentially given the DoD the ultimatum of either cutting costs for beneficiaries, wherever possible, or possibly have benefits arbitrarily cut by Congress. In the face of this possibility, cutting costs through better business practices must be explored particularly within the realm of pharmacy operations. This project explores the possible cost savings that might be realized by implementing Lean Six Sigma (LSS) methodologies in pharmacy operations of Medical Treatment Facilities (MTF).

We have developed simulation models to analyze and improve pharmacy operations of small, medium, and a large MTFs using discrete-event simulation software. Upon validation of the simulation models, system changes were tested in order to forecast their impact on costs, patient processing times, and overall efficiency. The research proves that implementation of Lean Six Sigma methodologies will improve military pharmacy operations, often at little or zero cost, while realizing significant savings and increased customer satisfaction.

THIS PAGE INTENTIONALLY LEFT BLANK

## I. INTRODUCTION

Rising healthcare costs are a fact of life for U.S. citizenry, both in and out of uniform. Military personnel costs are skyrocketing, and the biggest percentage of this growth is coming from the military healthcare system. The military must look at fixing healthcare on its own as good stewards of taxpayer dollars, and before a possible congressional “fix” that could be more counterproductive. The congressional efforts of adding to the overall costs with TRICARE for Life and extended Reservist eligibility for TRICARE, makes the current military healthcare situation even worse. The prognosis for the state of military healthcare does not look good with growth of at least 1 percent a year forecasted by the military. The Congressional Budgeting Office (CBO) forecasted growth of 3 percent, with an anticipated deficit to the system of approximately 38.4 billion dollars (CBO Paper, 2006). The cost of pharmacies is the single biggest continuous line item on any hospital budget.

The purpose of this study is to use Lean Six Sigma (LSS) methodology to study operations within the pharmacies of Medical Treatment Facilities (MTF) to improve operations and realize quantifiable benefits in terms of improved efficiency in the use of manpower, facilities, and pharmaceutical cost savings. Since 2001 (post 9/11) and the institution of TRICARE for Life (TFL), pharmacies have seen significant increases in customers, and subsequently increased costs. Congress has mandated using civilian business organizations as benchmarks to improve efficiency in the hopes of saving money within the military. Previous work done in analyzing military pharmacies has studied benchmarking, Coon (2006), and least cost procurement methods, Henning (2008); but neither of these has involved possible efficiency and financial benefits that could be reaped from utilizing LSS methodologies in military pharmacies.

This MBA project involves the utilization of LSS tools to improve small, medium and large pharmacy operations of military medical hospital. The facilities studied were the Defense Language Institute (DLI) medical clinic pharmacy in Monterey, CA; the Travis Air Force Base hospital, consisting of three pharmacies in Fairfield, CA; and the Balboa Naval Medical Center pharmacy in San Diego, CA. Chapter II, through a



literature review, discusses pharmacy costs associated with manpower, facilities, and dispensing, and what impact the congressional legislation has had on them. Chapter III discusses issues related to the pharmacy customers: hospital staff, the DoD, beneficiaries, and taxpayers. Chapters IV, V, VI, and VII illustrate the use of selected LSS tools to depict a cost benefit at the three medical treatment facilities. Chapter VIII provides the project summary, conclusions, and recommendations for further implementation and study in the area.

## **II. LITERATURE REVIEW OF LEAN SIX SIGMA APPLICATIONS**

This chapter presents a review of existing research and ideas about the use of Lean Six Sigma and methodologies as it applies to pharmacy operations. In addition, it familiarizes the reader with contrasting points of view on the topic, and sheds light on the strengths and weaknesses of these studies. The importance of the implementation process in each of five phases of Lean Six Sigma will be discussed.

### **A. LEAN SIX SIGMA**

Lean and Six Sigma has actually been around for a number years, but existed as two separate and contrasting ideas. For example, “Lean improvements focus on process speed and waste removal while Six Sigma, like its predecessor, Total Quality Management (TQM), focuses on the removal of process defects and the reduction of process variability” (Apte & Kang, 2006, p. 9). When a process is Lean, process activities that do not add value to the customer has been eradicated, and only the “absolute minimum of resources to add value to the product or service” remains (Apte & Kang, 2006, p.10). Furthermore, Lean focuses on the elimination or reduction of eight types of wastes. These wastes according to Apte & Kang (2006) are, “Human, Talent, Over-production, Waiting time, Transportation, Processing, Inventory, Motion, and Scrap” (Apte & Kang, 2006, p.10). When waste is eliminated, benefits such as reduced production time, quality improvement, and cost reduction are attained.

Overall, Six Sigma focuses on identifying issues dealing with variation within an activity or organization and then, through the use of specific tools, seeks to eliminate the variation. The goal is to remove waste in a process and reduce process inconsistencies. Six Sigma seeks to identify and remove the causes and defects in business processes by using quality management techniques. Apte & Kang (2006) supports this belief by stating that, “Six Sigma is all about locating and eliminating root causes of process problems” (Apte & Kang, 2006, p. 9). By eliminating errors and defects in a process, organizations obtain improved customer satisfaction, which results in increased profitability.

Six Sigma uses a meticulous and structured approach to process improvement. This approach consists of five phases, and is referred to as, DMAIC (Define, Measure, Analyze, Improve, and Control) (Apte & Kang, 2006, p. 13). In the Define phase, the customer, their requirements for services and products, and their expectations are defined. This phase also includes a process flow chart that defines the process that needs is in need of improvement. In the Measure phase, a data collection plan is developed and data is collected from various sources to determine what metrics will be used. The Analyze phase involves analyzing the data collected and the process map from the previous phase to determine the root causes of defects, and whether or not there are gaps between current performance and performance goals. This is also the phase where sources of variations are identified. In the Improve phase, creative and innovative solutions are designed to fix and prevent the existing problem followed by the development and organization of an implementation plan. Finally, the Control phase involves controlling the improvements so that the new process does not revert back to the old process. To be successful, this requires the development and implementation of a continuing monitoring plan.

More recently, practitioners who believed that Lean and Six Sigma can only be used as separate methodologies have come to realize that both approaches are “dependent on each other for greater success” (Apte & Kang, 2006, p. 14). Although these methodologies can still be used separately, together, they result in tremendous process improvement.

## **B. APPLICATIONS FOR COST REDUCTIONS IN MANPOWER**

Brian Robinson (2008) defines Lean Six Sigma as a process improvement methodology that focuses on both efficiency and quality through the following methods: determining the problem and defining metrics for measuring the problem; gathering information about the problem and preparing it for analysis; identifying why people are not doing what they’re supposed to and why a process fails to provide necessary controls; deciding what improvements are needed and implementing them and finally checking to see that implemented changes are continuous (Robinson, 2008, p. 34).

The Lean Six Sigma methodology is applicable across industry sectors and can lead to substantial cost and process improvement benefits. For example, the Department of Defense (DoD) has adopted Lean Six Sigma as its tool of choice for improving efficiencies, solving business process problems, and saving money. In his article, “DoD Rallies around Lean Six Sigma,” Brian Robinson (2008) states that, “for DoD, Lean Six Sigma has been in use in various places in the military since the 1990’s, but its use greatly expanded after 2000” (Robinson, 2008, p. 32). In 2007, the Army estimated a savings of \$1.2 billion after completing 770 projects, a savings credited to its implementation of Lean Six Sigma. Another success story is “the use of Lean Six Sigma by the Army’s Armament Research, Development and Engineering Center, which helped it win the National Institute of Standards and Technology 2007 Malcolm Baldrige National Quality Award, one of the top national prizes for performance management and business quality” (Robinson, 2008, p. 34). The Army has received awards from Utah State University’s College of Business for excellence in manufacturing based on their use of Lean Six Sigma methodology. For example, prior to the Army’s use of Lean Six Sigma their Humvee refitting operation averaged three a day. After Lean Six Sigma application, Humvee revamping operation averaged 23 rebuilds per day.

Other services within the DoD and within the government have also had success with Lean Six Sigma. According to Robinson (2008), “the Navy Air Systems Command, which developed a new approach to the joint Standoff Weapon Block II program by using Lean Six Sigma, generated savings of more than \$133 million in fiscal 2006 and more than \$420 million for the life of the Navy/Air Force program” (Robinson, 2008, p. 34). To further illustrate successes with Lean Six Sigma methodology and its contribution to process improvement, in June 2007, a joint effort by DoD, the Office of Management and Budget (OMB), and the Office of Personnel Management (OPM) “completely re-engineered the government’s security clearance process” using Lean Six Sigma (Robinson, 2008, p. 34). This was “one of the most ambitious Lean Six Sigma projects” (Robinson, 2008, p. 34).

It is clear that this article presents a one-sided argument in relation to Lean Six Sigma and how successful it has been for the Department of Defense and various

departments throughout the federal government. Robinson is clearly singing the praises of Lean Six Sigma methodologies and does not present a counter argument. The author's claim is that Lean Six Sigma methodology is so effective that even the Department of Defense is using it. This article relates to our research as we seek to apply Lean Six Sigma methodologies to pharmacy operations in small, medium and large Medical Treatment Facilities (MTF) to determine possible process improvements and cost savings. Understanding how other organizations applied the Lean Six Sigma concepts to their processes and the outcomes provides us with a fundamental knowledge base of how we should approach our study.

In their article, "Lean Six Sigma in Healthcare," Koning et al. (2006), illustrates the use of Lean Six Sigma methodologies in the healthcare industry. The article supports the notion that Lean Six Sigma can be used to improve any organizational process regardless of industry. The author reiterates the point that with the increasing cost in healthcare, implementing Lean Six Sigma methodologies is critically important to a healthcare organization by providing better healthcare, improving quality, and controlling healthcare cost increases. There are numerous departments within a hospital that can experience operational inefficiencies. These inefficiencies can be associated with direct medical care delivery processes, pharmacy operations processes, logistical processes and administrative processes, just to name a few.

The author uses an analogy to illustrate similarities between logic underlying the healthcare processes and the Lean Six Sigma methodology. For example, the article states that five phases of Lean Six Sigma are similar to the steps taken in healthcare procedures in that, "relevant information is assembled followed by careful diagnosis, a treatment plan, and then implementation of the proposed treatment plan. The final step is to check to see if the treatment was successful (Koning, 2006, p. 5). This parallels the DMAIC phases of Lean Six Sigma. The author's ability to present her ideas to an audience in their language contributes to a greater understanding of the overall process of how Lean Six Sigma is implemented within healthcare.

Not only has Lean Six Sigma methodology been applied across industries, it is also being utilized across nations. For example, in Koning's (2006) article about a Red

Cross hospital in the Netherlands, management found that Lean Six Sigma methodology provided solutions to many of their existing problems. The article systematically takes us through the five phases of Lean Six Sigma. For example, in the Define phase, the hospital determined that there were numerous problems that needed to be addressed. Their list of problems included shortening length of hospitalization for patients with chronic obstructive pulmonary disease; reducing the level of invoice errors from temporary agencies; revising the terms of payment; allowing parents to stay in rooms with hospitalized children; reducing the requirement for intravenous antibiotics; shortening the preparation time of intravenous medication; reducing the number of mistakes found on invoices (Koning, 2006, p. 7). As the author states, inefficiencies can be found in any department throughout any hospital ranging from administrative to patient care delivery. The analysis phase revealed that only 15 percent of the invoices were correct. The goal of the hospital was to have a 100 percent accuracy regarding invoices. Further analysis found that important signatures were missing, breaks were not recorded, there were inaccuracies on hours worked and incorrect hour wages were applied, to name a few. It was discovered that the root cause of the problem was the fact that there were differences in the invoices used by different temporary agencies. As part of the improvement phase, the hospital implemented a standardized worksheet, centralized request for temporary employees, reduced the number of temporary agencies previously used, and implemented a system that checked invoices for accuracy. These changes “resulted in reduced rework and significant cost savings” (Koning, 2006, p. 9).

The relevance of this article lies in the fact that it depicts the successful application of Lean Six Sigma methodologies in a healthcare setting, and supports the idea that along with cost savings, process improvement also results in improved employee morale. The article brings to light the qualitative effects of using Lean Six Sigma methodologies and although morale cannot be measured, it is certainly important to any organization.

### **C. APPLICATIONS FOR FACILITY REDUCTIONS**

In her article “Using Six Sigma and Lean Methodologies to Improve Operating Room (OR) Throughput,” Fairbanks (2007) illustrates the importance of the five phases of Lean Six Sigma, by depicting how a hospital in Vermont improved patient throughput by implementing Lean Six Sigma methodologies for patient who was undergoing elective surgery. According to Fairbanks (2007), the project comprised of five phases; Define, Measure, Analyze, Improve, and Control. In the Define phase, the “project began with the perception that surgical procedures could not be scheduled in the OR in a manner that met surgeon or patient needs” (Fairbanks, 2007, p. 75). To help further identify the problem, the project team distributed surveys to nursing staff and grouped survey responses into major themes. Based on the survey responses, procedural delays were determined to be the major cause of the problem.

In the Measurement phase, the use of computer programming was necessary in order to obtain scheduling information from the OR. Charts and graphs were created based on the scheduling information provided by the OR. Using this data along with statistical methods, the information was analyzed to “understand the cause-and-effect relationship in the process or system” (Fairbanks, 2007, p. 77). This allowed the team to determine where improvement efforts can best be applied. An important factor for the analysis phase is that solutions are based on data rather than on assumptions.

As with any organization, support from leadership and open communication is essential to process improvement. Specific to this hospital, the Improvement phase required that leadership and all healthcare providers continuously maintain open communication and commit to “doing things differently from the way things had been done for many years” (Fairbanks, 2007, p. 80). In addition, Fairbanks (2007) states that support from leadership “was critical to the success of the Improvement phase. The changes in the hospital’s patient flow process resulted in a dramatic on-time improvement from 12 percent in December 2005, to 89 percent (Fairbanks, 2007, p. 80). This dramatic change was attributed to the eliminating the amount of time it takes to transport patients, administering anesthesia and other necessary medications in a timely manner, surgeon’s

confidence that patient will be transported on time when they are finished on time, and eliminating telephone calls and communication among team members when patients are admitted. In addition to an improvement in surgeries being completed on time, turnaround times also decreased from a mean of 23.8 minutes to 17.9 minutes (Fairbanks, 2007, p. 80).

The final phase, the Control phase assures that improvements are sustained. In this hospital setting, staff members were assigned specific tasks to ensure sustainability and to ensure that there is no “loss of interest by stakeholders.” According to Fairbanks (2007) “changes can be difficult to maintain, and only by vigilant control of the gains can practices be kept from slipping back to previous patterns” (Fairbanks, 2007, p. 81). Although Lean Six Sigma focuses on process improvement, an important outcome in this hospital project was the improvement in morale among staff members. Fairbanks (2007) states, “after Lean Six Sigma initiatives were employed, staff members noted a greater sense of cohesiveness, collaboration, and pride in their accomplishments” (Fairbanks, 2007, p. 81).

Similar to some of the previously discussed articles, the author presents a thorough description of actions taken in each of the five phases. This body of information contributes to our knowledge of DMAIC and broadens our understanding of the importance of conducting each phase thoroughly. The article allows us to see the outcome when theory is successfully put into practice. Although it significantly contributes to our study, the article like many others, only point out successes and does not provide a counter argument regarding the applications of Lean Six Sigma methodologies. The claim in this article is that Lean Six Sigma works.

#### **D. APPLICATIONS FOR DISPENSING PRACTICES**

In her article, “Lean Six Sigma Reduces Medication Errors,” Grace Esimai (2005), illustrates the use of Lean Six Sigma methodologies in a healthcare setting, specifically a pharmacy in an anonymous hospital. Similar to the previous article, Esimai (2005) walks the reader through the five phases and provides detail descriptions of what was done in each phase, and the outcomes. The problem at this hospital directly relates to



our study. They were experiencing an increase in the rates of error in medication administration records. A project team was assembled with an objective to conduct investigations and come up with a process that would greatly minimize medication errors. The project team consisted of individuals who were in positions to “recommend and implement interventions to error reduction” (Esimai, 2005, p. 51).

The project team began by defining the problem and for the purpose of consistency, determined that the most urgent problem was the unknown error rate in the hospital medication administration records. They “reviewed and verified the process maps against current practices and sequence of operations” (Esimai, 2005, p. 52). They reviewed the errors found in the pharmacy medication order entry process (OE), and began to clearly define those errors and their origins. Subsequently they discovered that physician comments and instructions that were indicated on original faxed orders were not being inputted by the pharmacy, medication dosage were different from the original faxed order, wrong drug or different description from original faxed order, frequency differ from original faxed order, certain medication were omitted without reasons, some were profiled twice with different prescription numbers, discontinued medication were still being entered into the pharmacy OE., faxed medication not received or could not be located by pharmacy personnel, incorrect profile of medication order, and medication were profiled and routed incorrectly (Esimai, 2005, p. 52).

The project team found that some employees committed as many as 112 errors in a two-month period while some committed zero errors. The team reviewed the errors with employees and found that many of the errors were committed because of a “misunderstanding of certain guidelines and instructions” (Esimai, 2005, p. 53). So that everyone was clear on the standard procedures, the pharmacy conducted training and provided close supervised its personnel to ensure that standard procedures were being adhered to. The project team used statistical methods to estimate the trends of the errors and created charts and graphs that depicted positive trends.

After the investigation, in the Analyze phase, the project team found that there were many contributors to the existing problem. For example, they found that there were problems with the fax machine, problems with understanding physician’s handwriting,

distractions and interruptions when entering information in the system, non-reconciliation among nurses and pharmacist regarding the route, frequency and times of day to administer medication, and oversight due to human errors attributed to stress and an unpleasant working environment.

Part of the Improvement phase involved redesigning the pharmacy's process maps and installing new equipment. The project team also recommended that the hospital institute a high performance standard through instruction and supervision, fully implement computerized physician order management, install a system to separate the fax line from the phone lines, agree on standards of medication administration, designate one pharmacy employee to handle all external calls, and finally, hold monthly meetings so that nurses and pharmacist can build better relationships. Esimai (2005) suggests that, "in healthcare, the best approach appears to be error prevention using software that flags mistakes so employees will take immediate corrective action" (Esimai, 2005, p. 55).

The implementation of Lean Six Sigma at this hospital resulted in a decrease in the number of order entry errors, a decrease in total error rate from 0.33 percent to 0.14 percent in five months, and an estimated labor cost reductions of \$550,000. In addition, "improved employee morale and better relationship between nurses and pharmacists" along with patient satisfaction were also results of the success of implementing Lean Six Sigma (Esimai, 2005, p. 57).

This article directly relates to our research and provides us with a road map for conducting our study. It utilizes graphs and charts to provide quantitative analysis and support for the qualitative portion of the study. Like many other article, there is no counter argument provided. The author was clearly pro Lean Six Sigma. Importantly, the article was thorough and provided us with a foundation for how we are going to approach the five phases of Lean Six Sigma when conducting our research.

By implementing the Lean Six Sigma approach, many organizations have realized that it is possible to streamline their operations to create value that would benefit management, employees and customers. The bottom lines of companies have soared with the successful implementation of Lean Six Sigma. Organizations are drawn to the

Lean Six Sigma methodology because it can be implemented and produce results rather quickly without increase cost to the organization.

The previous articles all presents Lean Six Sigma in a positive light without providing any counter arguments and without illustrating anything that can essentially go wrong. Not surprisingly, not everyone shares the belief that Lean Six Sigma is a cure all for cost savings and process improvement. In his article, “A Values-Bases Critique of Lean and Six Sigma as a Management Ideology,” Dr. Christopher R. Paparone (2008) suggests that “organizational cultures that are attracted to the Tayloristic (scientific management) qualities of LSS-type systems may be blinded to other important interpretations of effectiveness and criteria for decision making” (Paparone, 2008, p. 35). Paparone does not suggest that Lean Six Sigma does not work; rather, he suggests that total reliance on Lean Six Sigma for process improvement will cause an organization to miss opportunities to learn new ways of improving their processes. Paparone presents his argument in a way that other articles on Lean Six Sigma have not. He does not dispute that Lean Six Sigma methodologies are useful in some instances, but warns against total reliance on what he views as an ideological method.

### **III. COST OF THE PHARMACY**

This chapter discusses the cost of Military Healthcare and specifically the cost of MTF pharmacies in such areas as manpower, facilities, and pharmaceuticals. The chapter also discusses Congressional legislation and policy on pharmacy benefits to beneficiaries and the impact it has had on the total cost of the military pharmacy on its customers.

#### **A. PHARMACY COSTS**

This section discusses the current military healthcare situation. At present the U.S. military is fully engaged with commitments to the Global War on Terror and other Stability and Support missions across the globe. As a result of these worldwide commitments, funding within the Department of Defense has become a critical issue and more so with the joint service medical departments. The medical departments have to fund deployed troops as well as provide needed support for veterans, and service members alike, not only in forward deployed areas, but also in the United States. Regardless of the actual size of the annual Defense Authorization Act, Congress cuts the defense budget annually. The subsequent effects of these budget cuts are seen throughout the services' respective medical commands that have to operate their departments with what they believe to be a minimal amount of staff to provide the maximum amount of capacity. One such department is the pharmacy, which is located within every medical treatment facility.

The Defense Department has also long operated on a “spend it all-up” culture in regards to budgeting. This defense spending culture must be overcome, particularly when it comes to fully instituting civilian business practices, i.e., Lean Six Sigma, in the DoD in order to truly capture cost savings.

The current Congressional Budget Office (CBO) and DoD estimates put military healthcare spending at roughly 20 percent of the total money to be spent in the operations and support budget. As seen in Figure 1, medical has grown considerably since 1980 in comparison to other funded areas.

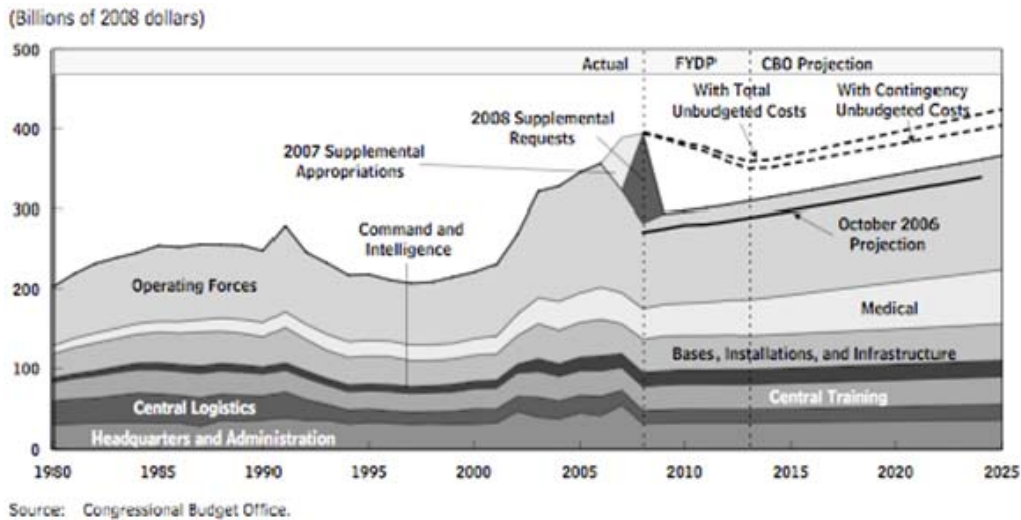

Figure 1. Past and Projected Resources for Operations and Support

The cost of medical benefits to beneficiaries is growing to encompass more than 20 percent of total Operations and Support monies. This is a fact of life in the civilian healthcare arena as well as the military. The DoD projected growth in medical spending was expected to be nominal with the proposed increase in co-pays and user fees; however, as seen in the 2008 Defense Appropriations Bill, that effort went unsupported by Congress. Now it is more likely that the CBO estimates of a growth in medical spending will increase to \$63.3 billion or a real expenditure increase of 65 percent is indeed more accurate (CBO Paper, 2006). These figures directly feed back into the analysis of the total Operations and Support (O&S) spending for the military. Increases in medical spending in (O&S) will account for 37 percent of the growth in that account by 2024. (CBO Paper, 2007)

The cost of the pharmacy is growing at a rate higher than that of the total cost of military healthcare itself. As in the civilian sector, pharmaceutical costs are growing at an alarming rate. These costs, as seen in Figure 2, for the military have “grown more than 200 percent” since 2000 and will likely continue to grow due to pharmaceutical company’s R&D costs (Henning, 2008). The 200 percent increase encompasses a growth in pharmaceutical funding of more than 40 percent.

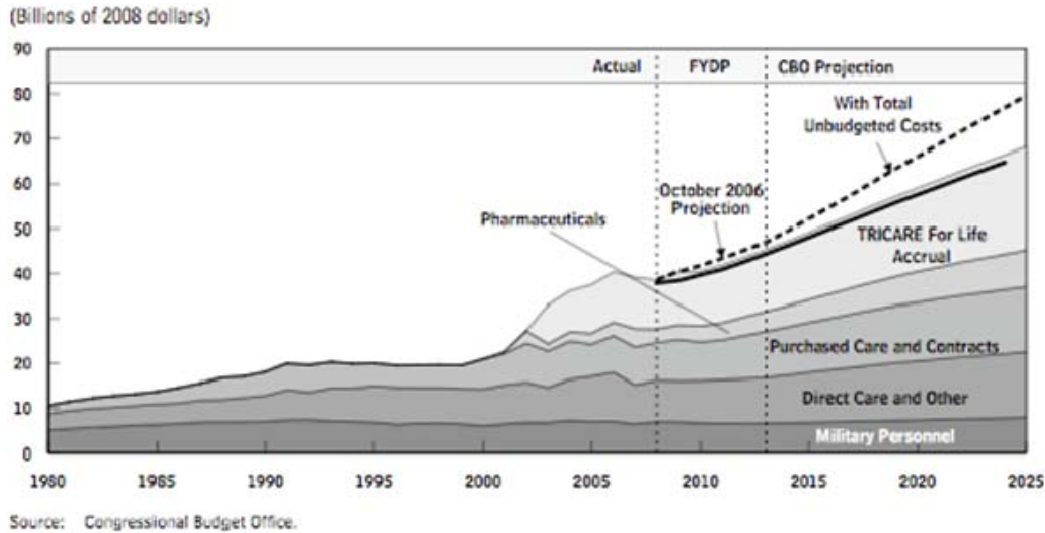

Figure 2. Past and Projected Resources for the Military Medical System

TFL is just TRICARE now since it essentially covers active duty from enlistment to retirement to death. TFL also must deal with the cost of continuous operations with supplements from beneficiary co-payments. With any other government-funded benefit whether it's a bridge, expressway or even a parking garage, there must be a payment on the part of the customer for the service. This service fee, or in the case of the pharmacy benefit a co-pay, is augmented or even gets reduced funding based on the anticipated fee. However, Congress has increased the pool of beneficiaries without regard to properly sourcing the funding, and restricted the medical department from increasing co-pays to make up for the difference. This has made and will continue to make a significant impact on TFL accruals as shown by the October 2006 projection with total unbudgeted costs in Figure 2. Based on this new Congressional policy or postponement of DoD policy regarding co-pay, CBO has changed their cost estimates for medical spending in the coming years. CBO now estimates a growth in medical spending to \$68.3 billion and a real increase of 77 percent.

TFL is funded by payments from beneficiaries and put into a healthcare fund and is in turn charged against monies appropriated for military personnel pay. If annual accrual charges are taken into consideration for that account, CBO projects that the

accrual changes for the TFL benefit will grow from \$9.3 billion to \$20 billion in the coming years (CBO Paper, 2007). Of that growth, accrual payments for the pharmacy will account for 40 percent. Regardless of the fact that MTF care for retirees is not a new benefit, MTF care for retirees over the age of 65 should be taken into consideration since prior to 2001 they fell under Medicare and Medicaid and would not have normally been seen at MTFs.

Now that costs involving congressional legislation, TFL, reserve benefits and cost sharing initiatives have been discussed; manpower, facilities, and dispensing will be outlined to demonstrate their impact on the cost of pharmacy operations.

**1. Manpower Costs**

A past and continuing trend in the military, and especially in the medical department, has been to utilize civilian manpower in lieu of military. A review of the most recent military and government service employee pay-charts for 2008 yields interesting information. The DoD is outsourcing its manpower to civilians at a cost higher than it would already pay its military service members. If it is taken into consideration that troop strengths within the services are quite steady and actually have grown in the years since 9/11, then these manpower costs would have to be considered as sunk costs. Table 1 depicts the average yearly salary for a pharmacy technician and a pharmacist under 2008 pay-charts.

Table 1. Pay Comparison for GS and military pharmacy employees

Worker	Pharmacy Tech	Pay	Pharmacist	Pay	Total
Civilain	GS4	\$25,824	GS10-12	\$58,210	\$84,034
Military	E1-4	\$20,358	CPT/LT	\$54,540	\$74,898

A typical civilian pharmacy technician starts at a GS 4 making \$25,824 a year and ranges up in grade while their military counterpart ranges in rank from E1-E4 averaging less at \$20,358 a year. DoD civilian pharmacists' average in pay grades from GS 10-12 and the average salary is \$58,210, while the military pharmacists are annually paid \$54,540. At first, the difference in salaries does not appear to be much in comparison at

just over \$9,000 annually, but this is just from analyzing the two types of employees at a single military pharmacy. If the difference is spread across all the employees at a typical pharmacy, the difference grows to \$40,137 including six technicians and two pharmacists. Moreover, if this difference is further spread to more than 230 military hospitals worldwide, that difference grows to over \$9,231,433. These costs are taken on just an average of six technicians and two pharmacists and do not include contracted employees that would considerably increase the final total. The DoD also plans to increase civilian employee pay at a rate of three percent in 2008 and 2.3 percent each year from 2009 through 2013 projecting that their pay would grow in real terms by 33 percent from present through 2025. (CBO Paper, 2007) Thus, the proposed outsourcing must be questioned for what true value it brings to the military. We have a volunteer military so the question is, are there enough servicemen available? It becomes a question of supply and demand.

## **2. Dispensing Costs**

This section will cover the three methods in which beneficiaries of DoD pharmacies are able to obtain their medical prescriptions: through local civilian pharmacies, through the TRICARE Mail Order Program, and through the local MTF pharmacy.

All three methods have their benefits to the patient; however, until the 2008 National Defense Authorization's Act there were different individual drug costs associated to all three programs, to the customer, and to the DoD. Before this act, the cost of obtaining medications through local civilian pharmacies did not fall under the Federal Supply System (FSS) and items such as aspirin varied in price between the MTF, civilian pharmacy, and TMOP. The costs beneficiaries would see for utilizing local civilian pharmacies were \$3 for generic drugs and \$9 for brand name drugs, the same as going through the MTF and TMOP. However, since those medications were not covered under the FSS agreement, the DoD would see significantly higher bills for their portion of the beneficiary visit to the pharmacy due to the procurement costs of drugs. As of



2008, the DoD pays the same for all three beneficiary procurement choices and the beneficiary continues to pay the minimal out of pocket expense of \$3 for generic and \$9 for brand name medications for a 30 day supply at the local pharmacy.

Now that dispensing costs for all three beneficiary procurement choices are the same for the DoD and are the same under the FSS agreement, there is not much of a benefit for further discussion on how to save money for the DoD and invalidates the previous work on least cost procurement methods, Henning (2008). Other studies have looked at the savings of time and the money that can be reaped by the beneficiary associated with their procurement method: MTF, civilian pharmacy, and TMOP. There is much to be considered here with the cost of fuel, time in line and overall convenience; however, this is not within the scope of our study.

What is within the scope of our study however, is how to save money and increase efficiency through implementing LSS methodologies in the MTF pharmacy. Pharmacy business operations and methodology will be discussed in the following chapter, but improvements in the cost of operations are directly impacted by the beneficiary's choice in medication procurement options. Refill medications take up approximately 15 percent of the MTF pharmacy's time, and the less time the MTF pharmacy spends on filling refill prescriptions the more time can be used on filling in-patient and outpatient prescriptions (Kelly, 2008). Freeing up the time of the MTF pharmacy from doing refills could improve efficiency on the aforementioned prescriptions and enable possible reductions in manpower, facilities and the volume of medications in the pharmacy. Of course, the effect on other military pharmacies of sending these refill prescription requests to them must be considered.

## **B. CONGRESSIONAL LEGISLATION**

This section discusses legislation and policy that has impacted military healthcare. It is broken down into four subsections discussing TLF, cost sharing initiatives, reserve benefits and new legislation for pharmaceuticals. It also specifically lays the background for costs that will be covered in Chapters V, VI, and VII.

## **1. TRICARE for Life**

TRICARE for life (TFL) is a relatively new healthcare benefit that extends medical and prescription drug coverage to beneficiaries that would have ordinarily sought coverage under Medicare and Medicaid. Although not contractually stipulated in enlistment contracts of service members, there has been a traditionally held belief that medical and prescription coverage would be a benefit to service members and dependants until death. In 2001, Congress enacted legislation that enveloped members and dependants under TRICARE ensuring continual coverage until death. TFL beneficiaries are able to seek medical attention at any MTF on a space available basis, but can utilize any MTF pharmacy without restriction.

## **2. Cost-sharing Initiatives**

The current legislated co-pay by beneficiaries for prescription drugs is \$3 for generic medication and \$9 for brand name medication. The Department of Defense planned to raise co-payments of beneficiaries for pharmaceutical benefits from \$3 for generic and \$9 for brand name drugs to \$5 and \$15, respectively (CBO Cost Estimate, 2008). However, the National Defense Authorization Act for 2008 defeated that plan in favor of freezing co-payments at their current level. This freeze will remain in effect through 2009 and will cover all beneficiaries of the Department of Defense pharmaceutical benefits. The CBO estimates that this reduction in planned co-payment amounts will increase direct spending under that program by \$99 million over the remainder of 2008 (CBO Cost Estimate, 2007). Without adjustments to beneficiary co-pays, at the very least to cover inflation, which “DoD’s own guidance stipulates 10.1 percent for pharmaceuticals,” the TRICARE pharmacy benefit will continue to accumulate costs for the program (CBO Paper, 2007). The pharmacy benefit to beneficiaries has significantly grown to cover baby-boomers and their dependants, a significantly expanded “active duty” reserve force, and a growing active duty force fighting the War on Terrorism. Without a raise in co-payments, a \$99 million shortfall in the cost of support to pharmacy operations will continue to grow over the coming years.

### **3. Reserve Benefits**

The U.S. Military Reserves and the states' National Guards receive medical, dental, and pharmacy benefits during their service on active duty. Since September 11, 2001, there have been numerous reserve and guard units that have been called to active duty for service in the continental U.S., Afghanistan, and Iraq. Most units being called to service are serving periods of at least 18 months. The service consists of six months of training prior to deployment and then a one-year deployment. After numerous incidents of deployment delays, due to medical issues with reserve and guard service members, deployment orders authorized members to start receiving benefits up to 90 days prior to their report date. This new procedure attempted to ensure all reporting members were medically fit for duty. However, for the DoD Healthcare system, this also meant a surge in the number of beneficiaries that started receiving benefits, lasting up to 22 months. With the current Global War on Terrorism, a healthcare system that is predominately sourced to provide care for active duty, dependants and retirees is being stretched beyond its means.

### **4. New Legislation for Pharmaceuticals**

Under current pricing for pharmaceutical procurement, pharmaceutical companies provide significant cost savings to the military under the Federal Supply Schedule (FSS). The military is able to provide medications through medical treatment facilities and the TRICARE Mail Order Program (TMOP) at the same reduced rates under the FSS; however, previously these reduced rates did not encompass medications procured by beneficiaries at retail pharmacies. Under the National Defense Authorization Act for 2008, section 703 now requires drug manufacturers to provide FSS pricing on purchases covered by TRICARE at all retail pharmacies. Again, this highlights the previous discussion on the identical pricing for all drugs destined for DoD patient consumption. The CBO estimates that implementing this section would reduce direct spending by \$2.6 billion over the 2008-2013 periods (CBO Cost Estimate, 2008). The new legislation has done a lot to address costs incurred by the Department of Defense from use of retail pharmacies by beneficiaries, but fails to address escalating costs within military pharmacies and the growing pool of beneficiaries of the pharmacy benefit.

## **IV. IMPROVING PHARMACY OPERATIONS USING LEAN SIX SIGMA**

This chapter contains the methods that were utilized in data collection in order to analyze the pharmacy process of our selected study sites. It also contains how we defined the customer. In defining the customer there are Critical to Quality (CTQ) issues involved with operations, not just at the pharmacy level, but also at the pharmacy user's level. In order to identify what was needed in the study the authors also formulated a project charter that outlined the project boundaries. Core business processes were also dissected in order to weigh the advantages and disadvantages of processes to satisfy all or most of the customer requirements, their expectations, and to identify better options for an improved process flow. That initial step will be shown as part of the SIPOC diagram.

The following three chapters will comprise three case studies of the locations included in our study. They will cover measuring the performance of pharmacy core business processes. Here we develop a data collection plan for those processes and determine possible defects and metrics for measuring them as well as performing customer surveys to measure possible shortfalls. They will also cover the analysis of data collected and the mapped process to determine the causes of problems as well as possible solutions. The analysis will also identify gaps between current performance at the visited sites versus their goal performance prioritizing opportunities for improvement and identifying sources of variation for elimination. The chapters will cover the improvement in the target processes by designing creative solutions to fix and even prevent problems all together. Here we inject innovative solution using technology within the constraints of each organization developing an implementation plan for possible future utilization. Finally, they will cover control of the improvement to keep the new process on course in order to revert to the old process as well as possible requirements for development, documentation and implementation of a monitoring plan.

## **A. METHODOLOGY**

This study attempts to utilize three methods of data collection and inference in order to explore the potential effects of Lean Six Sigma on pharmacy operations: Lean Six Sigma methodology, discrete-event simulation and personal interviews/surveys. In order to achieve the most accurate findings possible, all three methods together have been determined by the researchers/authors to produce the most thorough and comprehensive findings.

When applying LSS, the authors sought to eliminate inefficiencies within the observed pharmacy systems. By inefficiencies, we mean any process, step or procedure that negatively impacts cost within the system. As mentioned previously, savings in time, personnel, assets or resources may be equated to a savings in cost, and/or an improvement in customer service.

Initially, we considered the layout of the steps within each process. Much like a factory, excessive amounts of time that employees spend moving from point A to point B in order to perform tasks necessary for a process may be modified in order to realize a cost savings. In addition, variables such as proximity of necessary equipment, ease of communication between personnel, and location of key personnel, may also impact the various aspects of a LSS system and in many cases be easily modified.

Housekeeping can also play a significant role as excessive clutter, unnecessary equipment and personnel, or even too many tasks being completed in the same location can reduce the efficiency with which tasks may otherwise be performed.

Finally, the processes of each pharmacy will be screened to determine whether there are unnecessary steps within particular processes in order to eliminate procedures that have no added value to the system.

## **B. DEFINE THE PHARMACY CUSTOMER**

The authors used the commonly accepted Lean Six Sigma methodology as the basis for its application to pharmaceutical operations. The steps in Lean Six Sigma, Define, Measure, Analyze, Improve and Control (DMAIC) is the commonly accepted approach to its implementation, and were applied by the authors to pharmacy operations. The Define stage is discussed in this section and the other stages are covered in the following chapters.

The first step in the Define stage is defining the customer(s) followed by developing a project charter, developing a process diagram, and then obtaining the voice of the customer(s). We defined two primary customers in this stage, the patient and the DoD. Ultimately, the patient is the primary customer in the military healthcare system; however, for the purposes of our study and because we are also trying to determine cost benefits to the DoD through the use of LSS, we've also identified the DoD as a customer.

### **1. Project Charter**

We selected three military pharmacy locations that were geographically close and diverse in size and branch of service. For our study, we selected the Army's Defense Language Institute (DLI) in Monterey, CA; Travis Air Force Base in Fairfield, CA; and the San Diego Naval Base in San Diego, CA. Once the facility locations were identified for the study our team had to develop a project charter for the study. Once the project charter was completed, and the facilities were approved for inclusion into the study, the actual visit to the facilities took place. The actual project charter can be found in Appendix A. The charter presents a concise statement of what the project will encompass, what the project will do, and what the project will not accomplish, and is an essential step in the LSS process.

Due to its location and size, the first pharmacy visited was DLI. Since it was the smallest of the three facilities, we believed it would be the easiest to test data collection techniques and remedy any potential problems prior to visiting the larger pharmacies.

## 2. The Core Business Process Involved in Operations (SIPOC)

The basic core processes involved in all three facilities were constant throughout our study and can be seen below in Figure 3 in the SIPOC (Suppliers, Inputs, Process, Output, Customer) process diagram. Suppliers of drugs for these pharmacies were either the pharmaceutical prime vendor, Cardinal Healthcare, or an alternate source of supply through procurement with the pharmacy's government purchase card. Patients also had to be seen as suppliers of each pharmacy since they bring in the medication orders. The inputs were the actual pharmaceuticals and drug orders once they were processed in the system. The process was to receive them, process it for distribution, then give the filled order to the patient. The output was that the patient receives the filled order, and the government pays for both the inputs and the process. Finally, the customers identified were the patient and the DoD.

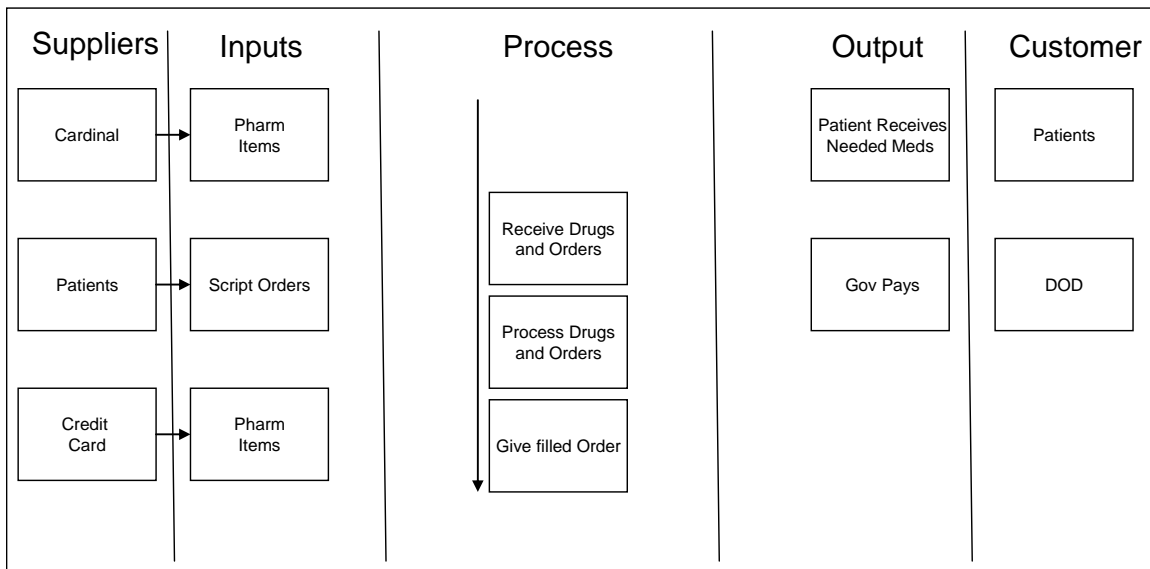

Figure 3. SIPOC Process Diagram

### **3. The Critical to Quality (CTQ) Issues Involved in Operations**

To more fully understand the customer, we also needed information on the voice of the customer. As customers, the problem for the DoD was clear. For the patient however, the problem is not as clear. For the purpose of the study, in order to define the potential problem(s) faced by patient customers, the team had to ask patients directly by having them complete surveys. Appendix 2 is the patient customer survey that was utilized to obtain the voice of the patient customers. The survey covered questions about patient demographics, about travel time to the pharmacy, wait time information, and their overall satisfaction with pharmacy services.

The authors conducted a survey of patients of each pharmacy in order to gauge the overall effectiveness and quality of service of the respective pharmacies. We also attempted to measure patient satisfaction and the receptiveness to changes within the current processes, which may impact patients. Measurements such as the convenience of the pharmacy location and the reasons for utilizing one pharmacy over another may also indicate satisfaction and cost impact of one particular pharmacy over another.

The sample population was taken from all outpatients physically utilizing each pharmacy on the days visited by the authors. Race, ethnicity and gender played no role in the population selection and were not measured. Surveys were conducted face to at the pharmacy locations themselves. Inpatients and medical personnel utilizing pharmacy services did not participate in the survey and were not measured. 83 percent (17 percent chose not to participate) of the patients visiting the pharmacy participated in the survey.

Identifying the customer and defining the problem are the first steps in the LSS process. The problem, as previously stated, has been identified at the highest levels, as rising costs of health care and pharmaceuticals coupled with budget cuts and constraints leave the Department of Defense questioning how much to cut, and from where. The authors contend that significant savings may be seen through increases in efficiency and better use of manpower, thus cushioning the quality of pharmacy services from these cuts and cost increases.



There are several facets within the scope of this study regarding the customer. First, the pharmacy customers who will be receiving prescriptions must be considered because as end users, they will ultimately be affected by changes to pharmacy operations. Our hope is that any proposed changes will either positively impact, or have no impact on the quality of care and service that users of MTF pharmacies receive. It is important to note that patients are not the only end users of MTF pharmacies. Doctors and nurses requiring pharmaceuticals for emergent care patients are also indirect customers of MTF pharmacies. Personnel working within the pharmacy i.e., pharmacists, pharmacy technicians, etc, are indirect customers. While pharmacy personnel may not use the pharmacy, they will observe the effects of LSS and may be responsible for changes to current pharmacy operations. Commonly seen effects of LSS, such as increased efficiency, decreased workload and decreased manpower utilization, will ultimately benefit pharmacy employees making them customers of Lean Six Sigma. However, for the purposes of this study, these users are not beneficiaries of military healthcare benefits and will not be studied as customers.

Finally, MTF commanders and the Department of Defense are also considered indirect customers much in the same way as pharmacy employees. The previously mentioned increases in efficiency, decreased workload and manpower utilization can ultimately result in an overall cost savings in pharmacy and hospital operations. With costs of pharmaceuticals, and manpower shortages, any significant savings in cost and manpower will benefit the MTF commanders, and the Department of Defense as a whole.

## **V. DLI PHARMACY**

As previously stated, the authors are demonstrating the potential impact of LSS practices on overall savings within pharmacy operations and the impact of cost saving measures on pharmacy beneficiaries. The DLI pharmacy was the smallest facility included in our study and was chosen by the researchers to be representative of all clinic pharmacies throughout the military due to the population served by this and most other clinics. The clinic pharmacy employs two military pharmacy technicians and two civilian pharmacists (GS). The clinic maintains less than 300 line items of inventory and spends an average of \$90,000 per month on medications. The facility processes an average of 200 drug orders per day and 4,500 per month. The four employees process an approximate total of 50 orders per employee per day. The personnel cost of the four employees is a total of \$14,627 per month with a total of 4,500 scripts processed. This would value the cost of processing each script without considering drug costs or other overhead costs at \$3.25 per order. In order to identify a relative baseline and potential issues within the pharmacy, customers were asked what services were important to them and what potential problems might exist.

### **A. VOICE OF THE CUSTOMER (VOC)**

The survey conducted at the Defense Language Institute Health Clinic resulted in the participation of 39 patients. It was conducted during the pharmacy's peak hours from 0800 to 1200 hours, and 100 percent of pharmacy customers who entered the waiting area were asked to participate. Only four chose not to do participate citing an inability to due to chronic health conditions or illness. An additional three customers did not enter the waiting area, but instead, immediately entered an exam room or left the clinic altogether.

The survey, consisting of 39 participants, at DLI yielded the following data outlined in Table 2.

Table 2. DLI Pharmacy Patient Survey

Component				
<b>Army</b>	<b>Navy</b>	<b>AF</b>	<b>Marine</b>	
25.64%	28.21%	35.90%	10.26%	
<b>Status</b>				
<b>A/D</b>	<b>Retired</b>	<b>Dependent</b>		
89.74%	5.13%	7.69%		
<b>Frequency of Visit</b>				
<b>Less than monthly</b>		<b>Greater than monthly</b>		<b>Monthly</b>
71.79%		7.69%		20.51%
<b>Distance</b>				
<b>&lt;20 miles</b>		<b>20-50 miles</b>	<b>&gt;50 miles</b>	
97.44%		2.56%	0.00%	
<b>Mode</b>				
<b>Self-transport</b>		<b>Other</b>		
97.44%		2.56%		
<b>Favorability of home delivery</b>				
<b>Favorable</b>		<b>No opinion</b>		
58.97%		41.03%		
<b>Average Wait time</b>				
<b>&lt;30 minutes</b>		<b>30 min to 1 hr</b>		
92.31%		7.69%		
<b>Level of satisfaction</b>				
<b>Very Satisfied</b>		<b>Moderately Satisf</b>	<b>No opinion</b>	
61.54%		28.21%	10.26%	

The above figure further defines the customer base as well as measuring potential areas of concern for the pharmacy beneficiaries. Keeping in mind that these customers have a choice as to which pharmacy they use or whether to use a military or commercial pharmacy, it is important to understand the relative convenience of using the MTF. Although the results seem initially unremarkable, certain aspects of the patient demographic becomes significant when compared to the results of the other observed pharmacies that will be discussed later. In addition, patients were given the opportunity to comment or make recommendations regarding pharmacy operations. Although the majority of the comments were positive, long wait times, and relatively high level of customer service were two themes that recurred on a number of surveys. Due to competing demands of DLI students and active duty personnel aboard the installation, the majority of patients use their lunch break in order to receive refills or avoid any perceived wait on an initial prescription. After observing the number of patients in the pharmacy waiting area, some patients opted to return to work or other activities with the intention of returning at a later time when a wait time would be less intrusive on their schedules.

## B. PROCESS FLOW MAP

The actual processes at each facility were far more involved than what the SIPOC process diagram depicts. The DLI operation was the smallest of the three facilities and thus a little less involved. This can be seen below in the detailed DLI process flow map in Figure 4.

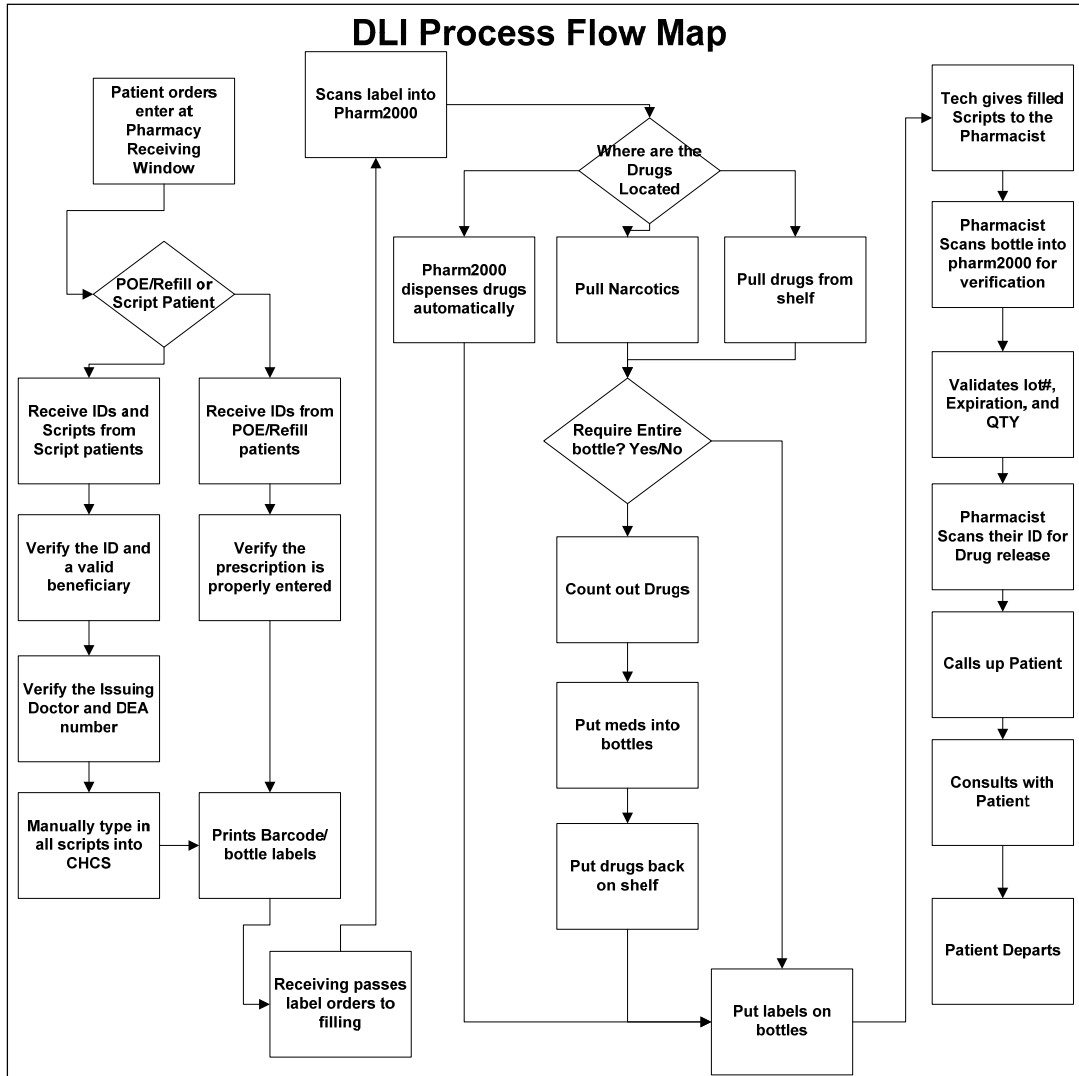

Figure 4. DLI Process Flow Map

Figure 4 depicts each process used within the DLI model regardless of its amount of time, value to the overall system, or its value and visibility to the customer. After the pharmacy opens to receive patients/scripts the customer can take one of two routes within the process map based on the type of script the customer requires. Note that outpatient scripts require additional processes within the system. When the two types of customers resume their common path, another “decision point” exists within the system based on the method each medication is dispensed. From this point, the flow once again becomes a common path as labeled bottles are dispensed to the patient.

The process as it is depicted above is the simplest process that the clinic can support based on the population served, the size of the operation, and budget constraints. The patient waiting in line to get to the window has no value added to the customer, and the minimal cost of approximately \$2,500 to institute an automated ticket dispenser would be extravagant given the average daily patient flow of 60 personnel.

The average wait times for patients’ waiting to drop off prescription requests ranges from 2 minutes to 25 minutes with a mean of 15 minutes given the current operational configuration. The clinic’s goal is to have an internal process time of three minutes not including the time spent waiting in line. The wait time adds no value to the patient and will be discussed later in this chapter. However, the non-value added wait time could be mitigated if the pharmacy were to accept script call-ins the day prior. Approximately 25 percent of the pharmacy’s business comes from walk-in script requests from civilian healthcare providers. A bottleneck at the receive IDs station is caused by this 25 percent of personnel and transcends through the entire process flow causing a longer wait time than would normally occur. The discussion on potential fixes for this process will also be presented later in this chapter.

### **C. DATA COLLECTION AND ANALYSIS**

The facilities chosen for the project was based on size and customer population and each facility has a markedly different structure and processes from the others. Measurements of current pharmacy operations have been taken through a variety of means to better analyze the potential effects of Six Sigma on pharmaceutical operations

and the identified customers. From each, we collected the cost data, usage data, projected goals (formal or informal) as well as overall customer/patient satisfaction with the current processes and service. In addition, each pharmacy's operations were observed first-hand by the research team in order properly map and time each process for later modeling and analysis.

The cost usage data was derived from a variety of sources, both internal and external to the pharmacy. The GAO and DoD resources as well as those of the pharmacies, MTFs, and civilian contractors and Prime Vendors will be used in order to obtain the most accurate data possible. In addition, a customer satisfaction survey, was used to measure the level convenience, or ease, with which pharmacy customers are able to utilize their services as well as the general "openness" to a mail order or a home delivery pharmacy system.

Performance metrics and variables had to be identified in relation to the respective processes within each of the three observed pharmacies before first hand data could be collected. The number of steps, or potential bottlenecks within the overall pharmacy operation is a significant measurement itself. The amount of time necessary to process patients, or their prescriptions, through each step and the number of personnel assigned to the processing of each step must be considered within the performance metrics. All three pharmacies were asked what performance metrics do they place upon themselves and all responses were the same. Their metric for success was the measure and reduced customer processing time. Not surprisingly, customer wait time was also the most important factor for the customer found in the voice of the customer in completed surveys.

## **1. The Fishbone Diagram Analysis**

The best way to identify savings (Chapter I) is to model the SIPOC process and process flow maps discussed above. Using the fishbone diagram, however, the authors were further able to dissect problems that were initially identified by the voice of the customer observations at the pharmacy. The information provided below is similar for all

four pharmacies and any differences will be discussed below in each chapter's fishbone diagram analysis. The fishbone (Ishikawa) diagram attempts to graphically display problems, their root causes, and their interactions. The fishbone diagram is a common LSS tool to assist in problem identification by breaking the problem down into bite-sized pieces (Kang, 2006).

The problems, as outlined in Figures 5 and 6, are the excessive costs, both material and labor, and the excessive patient processing times that occur in pharmacy operations and for the patient. These excessive costs will be the primary focus of our study and, later in our simulations, potential cost saving measures will become more evident.

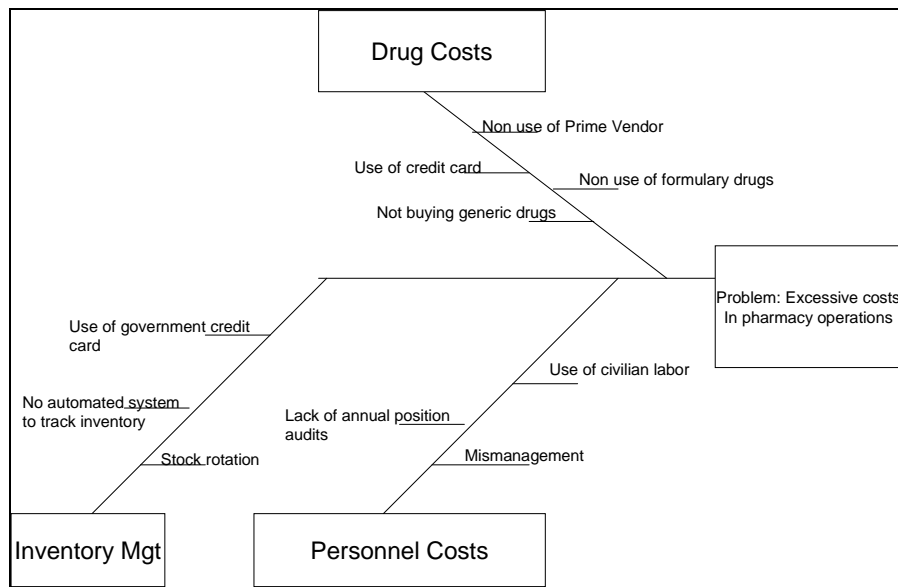

Figure 5. DLI Fishbone Diagram for Excessive Costs

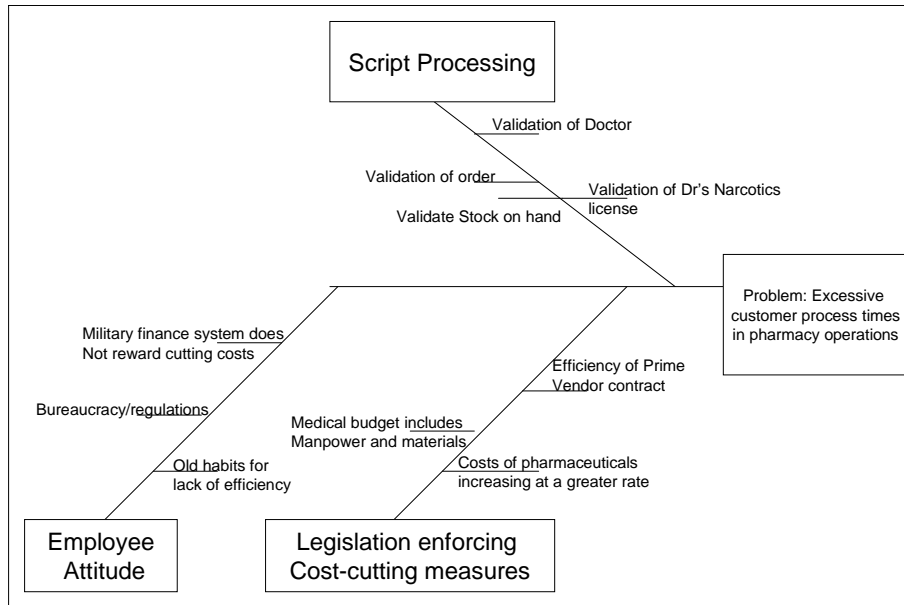

Figure 6. DLI Fishbone Diagram for Processing Time

Excessive cost is the first problem in the pharmacy, and is analyzed in Figure 5. The costs can be attributed to drug costs, personnel costs and a lack of inventory management. The drug costs can come from the lack of using the contracted pharmaceutical prime vendor. Not utilizing the prime vendor negates the benefit of having a contractually agreed low price on pharmaceuticals. Any purchase of drugs from a third party source or on the government credit card will incur higher procurement costs. Personnel costs are also an issue. Most of the pharmacies visited utilized contract employees or GS employees where military could have been utilized. A personnel audit of each job position should be performed annually to justify employees. Inventory management is the last cost. Not performing stock rotation or utilizing First In First Out for stocked medications leads to expired drugs. No automated inventory management system also leads to excess medications on hand, and with a prime vendor that resupplies daily there should be minimal lines stocked for daily use.

The second problem, analyzed in Figure 6, is that new scripts increase total patient processing time. The increased processing time comes from the validation processing that the receiving technician must perform as each new script arrives. The processing includes validation of the doctor, the doctor's narcotics license (DEA



number), validation of the order, and a validation that the medication is in fact stocked and on the formulary. Employee attitudes and legislation enforcing cost-cutting measures are also factors. The attitudes of the employees also show some issues with their old habits and processes with resistance to change or be open to new ways of doing things, regulations of a government bureaucracy can also pose certain issues, and the military finance system does not actually reward services and departments for cutting costs. A dollar saved this year is a dollar one does not receive next year. There are also legislative measures that require cost saving measures in the military; however, costs of pharmaceuticals continue to rise, and budgets continue to dwindle possibly offsetting potential gains from cost savings.

## **2. Collect Data for Determining Defects and Metrics**

The primary data collected from DLI were the patient process times from physically observing patients at the pharmacy, patient service volume reports collected from the pharmacy for the entire fiscal year 2008, and financial expenditures on medications. The volume reports reflected patient data broken down into three categories: POE, script patients from civilian healthcare providers and refill patients. The script patients were further broken down into retirees and pediatric patients. Neither retirees nor children are seen at the DLI clinic. The refill patients are broken down into either military patients or civilians. Below are the actual patient numbers seen for fiscal year 2008. The months of August and September were forecasts based on a trend analysis of all the prior months. Monthly totals and the annual average for each of the patients discussed can be seen below in Table 3.

Table 3. DLI Patient Volume Report

Month	Total	Military	Civilian	Pediatric	Refill	%POE	%Scripts	%Refill
October	4374	2135	1324	190	725	48.81%	34.61%	16.58%
November	3830	1885	1106	164	675	49.22%	33.16%	17.62%
December	3562	1828	853	190	691	51.32%	29.28%	19.40%
January	4390	2311	1254	204	621	52.64%	33.21%	14.15%
February	5389	3040	1431	223	695	56.41%	30.69%	12.90%
March	4820	2769	1175	229	363	57.45%	29.13%	7.53%
April	5247	3305	1129	169	644	62.99%	24.74%	12.27%
May	4550	2774	927	178	671	60.97%	24.29%	14.75%
June	4082	2351	805	130	796	57.59%	22.91%	19.50%
July	4871	3067	933	168	647	62.97%	22.62%	13.28%
August	4951	3183	898	165	645	64.29%	21.46%	13.04%
September	5031	3299	862	161	644	65.57%	20.34%	12.80%
TOTAL	40244	22398	10004	1677	5881			
AVG	4472	2489	1112	186	653	57.52%	27.20%	14.48%

The second type of data collected at DLI was the patient wait times. There was no special priority for patients waiting in line to be seen at the Receiving Window or within the pharmacy. However, there was a difference in process time between script patients compared to POE and refill patients. POE and refill patients could normally be serviced at the pharmacy-Receiving Window in less than one minute while the script patients would take from 2 to 20 minutes, at the same window, based on the amount of paper pharmacy scripts. There were only two script patients observed during the visit to DLI.

The non-value added time was not only experienced by the script patient, but also by the other patients waiting in line due to the bottleneck created at the single Receiving Window that processed script orders (variation). The crux of the problem was the time it took for the pharmacy technician to type into the system every medication script a script patient had, as well as verify the prescribing physician's Drug Enforcement Agency's prescriber number. This was a very tedious process in order to get each medication required for the script patient. The significant non-value added time could be forgone if script patients could call-in their prescription requests in the afternoon the day prior to coming in to pick up their medications. The analysis of this problem will be discussed later in the chapter, but implementation of a call in system could reduce overall wait time by as much as 4 minutes.

The last type of data collected from DLI was the financial expenditures on medications for the entire fiscal year. The expenditures are broken down into two categories: credit card purchases and prime vendor purchases. The Defense Logistics Agency (DLA) negotiates the prime vendor contract for the entire western region of the United States and is a joint services contract for all healthcare facilities within the region. The negotiated price is based on a joint pharmacy formulary of medications and a federal supply catalog of pricing for each type of medication. The contract is the best price the DoD can secure for its pharmacies to avoid facilities in certain geographical areas from paying higher prices. The contract also reduces the need to carry excessive amounts of inventory because it mandates a 95 percent minimum fill rate on all requests as well as next day delivery of all orders. However, the contract does not negate the need for the pharmacy to practice good inventory management.

Inventory management is an essential key to keeping costs down in the pharmacy. The stock rotation of medication must occur at each inventory item location to ensure the First In First Out concept to avoid expiration of potency and dated medications. The pharmaceutical expenditures from the prime vendor and on the government credit card could indicate further that proper inventory management is not being conducted at the DLI pharmacy. Below are the prime vendor and credit card expenditures for the 2008 fiscal year depicted in Figures 7 and 8 and Table 4.

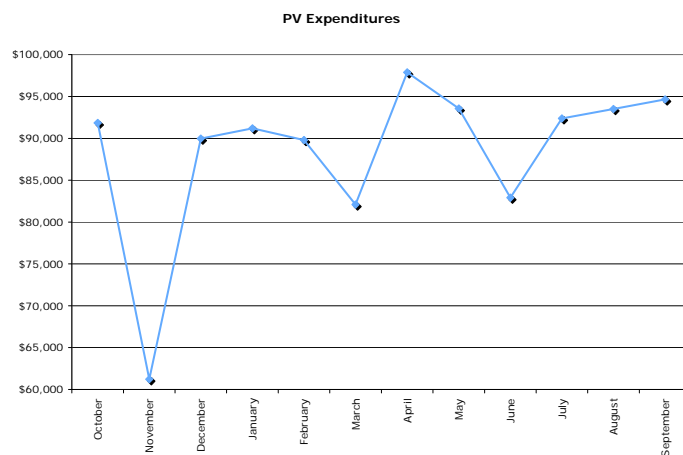

Figure 7. DLI Prime Vendor Expenditures for FY 2008

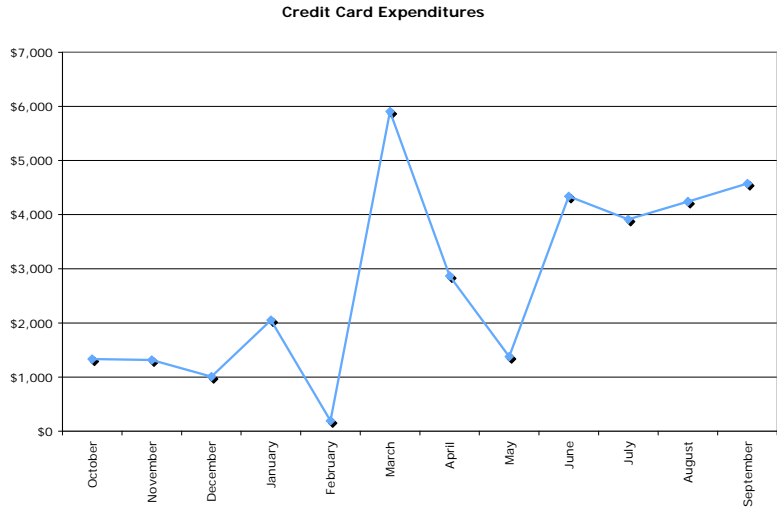

Figure 8. DLI Credit Card Expenditures for FY 2008

Table 4. DLI Total Pharmaceutical Expenditures for FY 2008

	PV	CC	Total
OCT	\$91,828	\$1,333	\$93,161
NOV	\$61,239	\$1,317	\$62,556
DEC	\$89,958	\$1,007	\$90,965
JAN	\$91,199	\$2,052	\$93,250
FEB	\$89,796	\$191	\$89,987
MAR	\$82,091	\$5,906	\$87,997
APR	\$97,869	\$2,869	\$100,738
MAY	\$93,558	\$1,376	\$94,935
JUN	\$82,898	\$4,340	\$87,238
JUL	\$92,378	\$3,915	\$96,292
AUG	\$93,510	\$4,244	\$97,754
SEP	\$94,642	\$4,574	\$99,217
TOTAL	\$1,060,966	\$33,124	\$1,094,090

DLI’s prime vendor expenditures range between \$62,000 and \$100,000 per month with total annual expenditures in excess of \$1,000,000. The biggest indication of a potential inventory problem is the use of the government credit card to procure drugs. The use of the government credit card is reserved for one-time procurements and for emergency need items. The use of the card, especially through the latter half of the year, demonstrates an issue with ordering supplies from the prime vendor. Again, the use of

prime vendor does not negate the need for inventory management, but it does help to defray the cost of pharmaceuticals. This is why most pharmaceutical government credit card purchases should only be conducted on an emergency basis since purchasing pharmaceuticals with the credit card does not have the benefit of reduced cost like purchasing through the prime vendor.

#### **D. SIMULATION ANALYSIS**

The authors observed the medical clinic at the Defense Language Institute in Monterey, CA and collected data in order to accurately model its current operations and processes. A model was then created in the Arena Software suite in order to accurately forecast any potential impact that changes in current operations may have on customer wait times and personnel utilization.

##### **1. Arena Simulation Model Information and Flow**

The flow of our model can be partitioned into five areas and each is discussed below. The areas consist of drugs entering the system, patients entering the system, drug orders entering the system, drug orders getting processed, and then patients receiving there drugs and leaving the system.

In our first area, Figure 9, we model drugs coming into the clinic pharmacy. There were three drug types: machine dispensed, shelf drugs and narcotics. The drugs arrive once daily in the morning and are added to the initial inventory. The drugs arrive and are in-processed by pharmacy technicians and remain in a Hold (i.e., inventory) until the pharmacy technician station Signals for the correct drug based on its Drug Attribute.

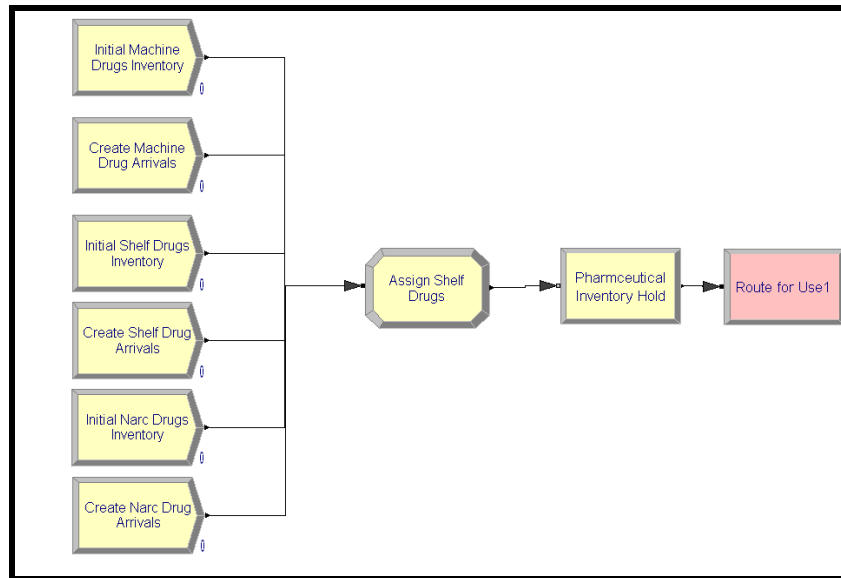

Figure 9. DLI Simulation: Drug arrivals and initial inventory

Figure 10 illustrates the patients entering the system. The inter-arrival time of patients was modeled using an exponential distribution. They arrived at inter-arrival time of one patient every 2.4 minutes as demonstrated by the pharmacy’s historical data. In the simulation models it is assumed that each patient brings an order for a single prescription. The patients were further randomly assigned an Attribute of “Patient Type” based on the historical percentages of patients served by the pharmacy. The Patient Types are Provider Order Entry (POE), script, and refill patients. POEs are patients seen by a physician within the military hospital whose scripts are entered manually by their physician. Script patients are those seen by a civilian care provider outside the facility. These patients physically carry their prescription to the pharmacy to be entered into the computer system by pharmacy personnel. Refill patients’ data is already present in the pharmacy computer system. Patients are further assigned attributes, pictures and variables. They are separated into patients and orders having a drug attribute and a ticket variable (TKT) to ensure a correct match of drug type to the ordered drug to the correct patient using the TKT variable later in the model. Patients and orders then flow to their respective areas for processing; patients to a “Waiting room” and scripts to “Inprocessing.”

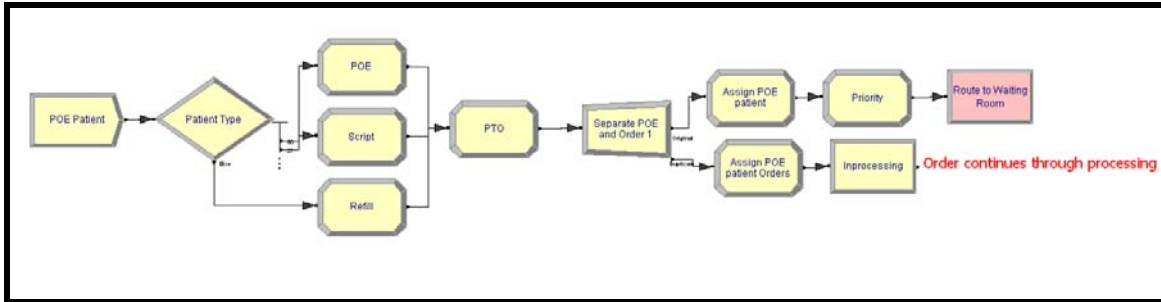

Figure 10. DLI Simulation: Patient arrivals

The third area of the discrete-event simulation, as seen in Figure 11, models the patients/orders proceeding to the Receiving Window that is processed by a receiving technician. The patients then flow into a waiting area while the orders separate from the patient and are assigned a drug attribute flowing into an order filling station. For the patients, a search module will then search for their processed order/drug by the TKT attribute. Patients will flow to a match module and wait until the correct, completed order is found.

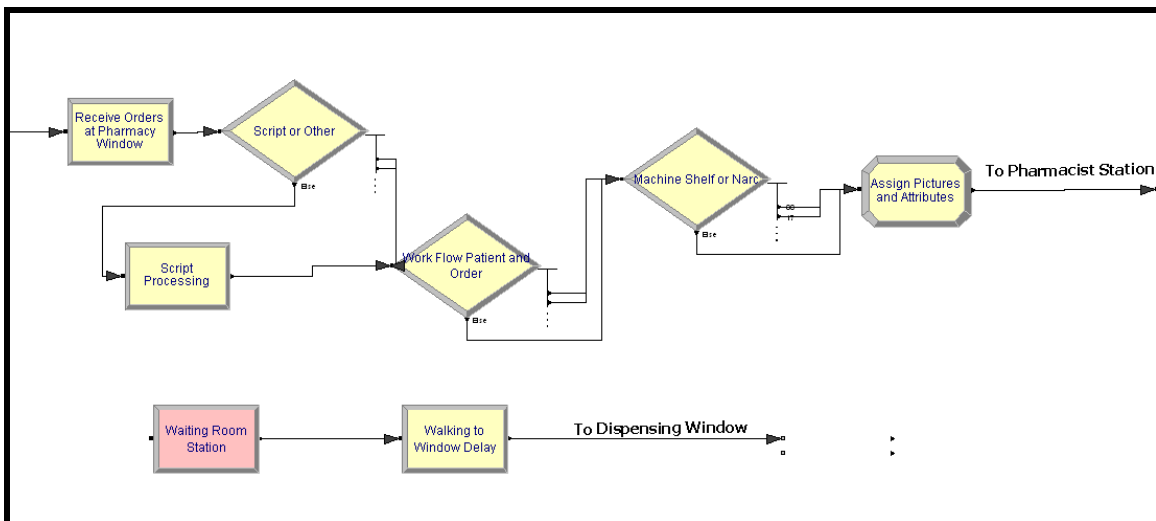

Figure 11. DLI Simulation: Initial patient and order processing

After the order is separated from the patient, as seen in Figure 11, the order flows through a decide module to allow for the additional in-processing required for script patients. Orders proceed further and are assigned pictures and attributes for animation

purposes. Patients, represented on the lower portion of the figure, are routed to a waiting area, where they will wait in queue to be matched with their proper order. Figure 12 models the orders being signaled from stock (the Pharmaceutical Hold in Figure 8) and then processed, matched by drug attribute, batched, and sent to the pharmacist. The filled order will then flow to the Pharmacist Station where they are verified for correctness and are passed to a match module where they search the Patient Hold for the correct filled order based on the TKT variable. In the Match Module, as seen in Figure 13, the TKT number matches the filled order and patient; then they are batched and processed out of the system.

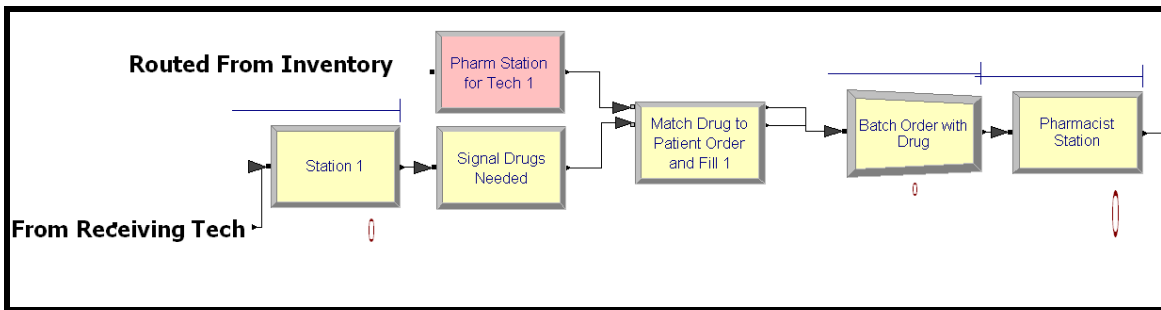

Figure 12. DLI Simulation: Physical filling of prescriptions

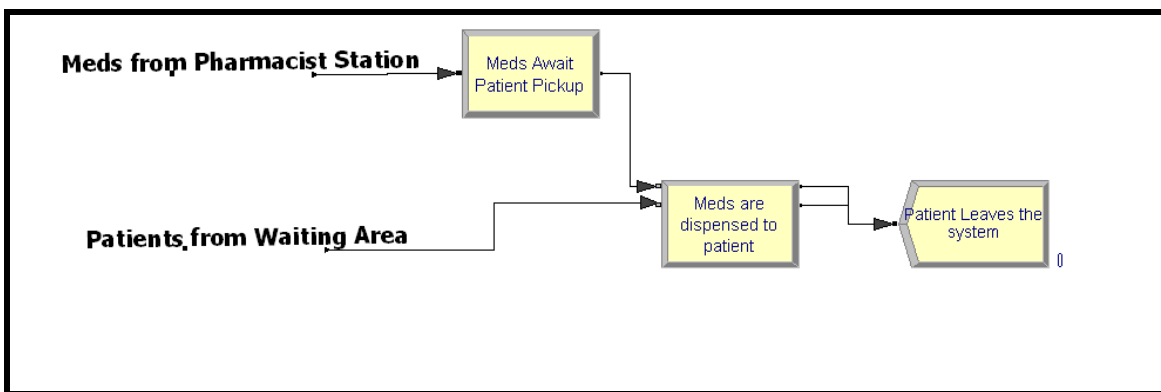

Figure 13. DLI Simulation: Matching of patient and filled prescription



## 2. Simulation Entities

The entities of the model were broken down into nine types that consist of three types of patients with corresponding order types in combination with three types of drugs. The three types of patients with corresponding order types are: POE patients, script patients, refill patients. Patients enter pharmacy and are assigned a patient type attribute (Provider Order Entry POE, Script, and Refill Patient). The arrival rates of the different drugs (automatically dispensed, shelf and narcotic) and the patients (POE, script, refill) were modeled as having inter-arrival rates per hour. The inter-arrival rate of patients is derived from an exponential distribution. During pharmacy business hours, patients enter the model every 2.3 minutes. They are further assigned an Attribute of “Patient Type,” randomly, based on the historical percentages of patients served by the pharmacy. 85 percent of the patients served are POE patients while 27 percent are script patients, and 15 percent are refill patients. POE patients, script patients, and refill patients are seen inside the clinic and have no priority in the pharmacy, meaning a bottleneck anywhere in the system (i.e., script patients) increases the overall processing times of all patients.

There are three drug create modules: machine, shelf and narcotics (narc). They also are assigned an attribute of drug with a corresponding one, two, or three to represent the type of drug their prescription is for. They are assigned a variable of TKT (ticket number) with an incremented attribute to correctly match not only the type of drug, but also the right drug order of the specific type. Their arrival into the system occurs during pharmacy hours of operation.

The machine drugs consist of 72 lines of their fast moving items and are automatically dispensed when the pharmacy technician, at the processing station, scans the printed label for the order. Their arrival into the system is based on a schedule and is assigned an attribute, drug type one. The shelf drugs are slow moving drugs that must be located, pulled, counted and then returned to the shelf. Their arrival is based on schedule and is assigned an attribute, drug type two. The narc drugs are narcotics that must be pulled from the safe, counted and then put back. Their arrivals are based on a schedule and it is assigned an attribute, drug type three.

### **3. Simulation Resources**

The simulation utilized two types of resources: windows and personnel. Both resources are available to be used according to a schedule based on the pharmacy's hours of operation. The model does not account for breaks, lunches or absenteeism; however, these factors are discussed in the conclusion found in Chapter VIII. The resources are also only available during pharmacy hours of operation. It is important to note that the pharmacy is staffed with four personnel, two pharmacy technicians and two pharmacists, each of which is responsible for more than one process. For example, the pharmacy-receiving technician set consists of any two of the four personnel that will be utilized at random to take orders at the pharmacy window as needed. The pharmacy technician set consists of two personnel and is utilized at random to process and pull drugs, process orders, and then take the order to the pharmacist for review. The pharmacist set consists of only two personnel (the pharmacist) and will primarily process filled orders for review of accuracy, but can also work at the fill station if needed. The final set is the stocker set that consists of all four of the personnel in order to process arrivals of medication from the pharmaceutical prime vendor; however, drug arrivals do not occur during the pharmacy's patient service hours and do not inhibit the work processes. From the personnel perspective, two pharmacy technicians are in both the receiving set and the fill set and two pharmacists are in both the fill set and the pharmacist set.

### **4. Simulation Processes**

The simulation consists of five processes. The "In-processing" Process requires both a technician and a Receiving Window. This is where the patient gives their prescription to the receiving technician at the Receiving Window. The receiving technician must process the patient in the system by swiping the patient identification card, verifying the prescription is properly inputted, and then printing a prescription label. To model the processing time we used a Triangular distribution with a minimum value of .5 minutes, most likely value of .7 minutes, and a maximum value of 1 minute (TRIA(.5, .7, 1)). Script patients must complete an additional process, "Script Processing" which

simulates the time taken to enter new patient data into the pharmacy computer system. This process requires one technician and one Receiving Window. “Script Processing” used a triangular distribution of  $TRIA(1, 1.25, 1.5)$ . There were only two script patients observed during the DLI visit. Each patient had several scripts that were processed with total processing times of 15 and 20 minutes. The processing distribution for scripts was an average of only those two patients each of whom averaged between 1 and 1.5 minutes per script yielding a total processing time of 15 to 20 minutes.

All prescriptions then proceed to the pharmacy fill station process that operates with two personnel and the “Fill Station”. The process used a Triangular distribution of  $TRIA(.75, .9, 1.1)$  that was observed by the authors and the pharmacy’s historical data. The utilized Triangular distribution took in to account processing times for all three types of drugs. Machine drugs were processed faster than other types of drugs; however, the overall distribution is representative of processing one script order at the fill station.

Finally, the “Pharmacist Station” randomly pulls from the set of two pharmacists to verify orders before signaling and issuing the filled order to the correct patient. This Process used a Triangular distribution of  $TRIA(.5, 1, 1.5)$ . Issuing the order to the patient also requires a Pharmacist Window.

The system also has a “Storeroom” process which randomly pulls from the stocker set to stock new shipments of drugs when they arrive into the pharmacy; however, this does not affect the patients, as it is performed before pharmacy business hours. It was included in the model in order to more accurately measure personnel/resource utilization.

## **5. Experiment Description**

In the model the authors experiment with controls on resources to vary the number of resources to see if there were any changes to the amount, by the type of patients, that we were able to serve and if there was a change in processing time. We utilized the discussed controls in an effort to reduce patient wait time and costs in the

pharmacy. If the model shows no significant drop in services or an increase in processing time by cutting personnel, then we could show that there is money to be saved. The results of the Process Analyzer are as follows.

Table 5 illustrates our experiments with the current resources and manning levels of the DLI clinic pharmacy that provides service to active duty members, dependents, DoD employees, and retired veterans. In the first scenario (1a) we ran what we believe to be an accurate representation of the current operations with no changes. At the request of DLI pharmacy personnel, we then examined the overall resource usage of the receiving and pharmacist dispensing windows, by measuring the overall output and resource utilization after increasing the number of “Receiving Windows,” and “Pharmacist Windows” (dispensing) by one, respectively scenarios 1b and 1c. In scenario 2a, 2b, and 2c the authors measured changes in processing times and resource utilization after changes were made to the number of personnel available for use in the pharmacy. We used each of the worker utilizations, and the processing times of each type of patient as a baseline for later changes/reductions in services. Scenario 2a represents normal operations with a decrease of one less pharmacist within the pharmacy, while scenarios 2b and 2c represent operations with a decrease in one pharmacy technician and an additional receiving and dispensing window, respectively. The additional window was only modeled at the request of DLI pharmacist.

Table 5. DLI Process Analyzer Model Results

NAME	REC WINDOW	PHARM WINDOW	CONTROLS						RESPONSES								
			TECH 1	TECH 2	PHARM 1	PHAR M 2	POE OUT	REFIL L OUT	SCRIPT OUT	POE TIME	REFILL TIME	SCRIPT TIME	TECH 2 UTIL	PHARM 2 UTIL	TECH 1 UTIL	PHARM 1 UTIL	Avg time per patient
Scenario 1a	1	1	1	1	1	1	239.8	64.8	103.9	33.43	35.065	37.64	0.39	0.41	0.41	0.392	35.38
Scenario 1b	2	1	1	1	1	1	239.8	64.8	103.9	33.43	35.065	37.64	0.39	0.41	0.41	0.392	35.38
Scenario 1c	1	2	1	1	1	1	239.8	64.8	103.9	33.43	35.065	37.64	0.39	0.41	0.41	0.392	35.38
Scenario 2a	1	1	1	1	0	1	231.8	72	103.3	69.13	67.884	101.36	0.46	0.47	0.48	0	79.46
Scenario 2b	2	1	1	1	0	1	231.8	72	103.3	69.13	67.884	101.36	0.46	0.47	0.48	0	79.46
Scenario 2c	1	2	1	1	0	1	231.8	72	103.3	69.13	67.884	101.36	0.46	0.47	0.48	0	79.46

Table 6 reflects a change in Script Processing times. As previously suggested, the authors contend that providing a means for Script Patients to call the pharmacy prior to submitting a new script would alleviate the occasional backlog currently experienced at the Receiving Window. This would reduce Script Processing times to equal those of

refill and POE patients. We then incorporated this change into our experimentation with the number of available windows and reductions in personnel. Scenarios 3 and 4 represent the DLI pharmacy with a “Call Ahead” service. In scenario 3 the number of available windows (receiving and dispensing) are increased while scenario 4 illustrates changes in personnel as well as the additional windows. Note that Scenario 3a represents only changes made for a call-ahead service with no changes in resources.

Table 6. DLI (with Script Call-in) Process Analyzer Model Results

NAME	REC WINDOW	PHARM WINDOW	CONTROLS						RESPONSES									
			TECH 1	TECH 2	PHARM 1	PHARM 2	POE OUT	REFILL OUT	SCRIPT OUT	POE TIME	REFILL TIME	SCRIPT TIME	TECH 2 UTIL	PHARM 2 UTIL	TECH 1 UTIL	PHARM 1 UTIL	Avg time per patient	
Scenario 3a	1	1	1	1	1	1	1	244.3	67.1	106.2	35.23	35.024	28.915	0.397	0.413	0.35	0.397	33.06
Scenario 3b	2	1	1	1	1	1	1	244.3	67.1	106.2	35.23	35.024	28.915	0.397	0.413	0.35	0.397	33.06
Scenario 3c	1	2	1	1	1	1	1	244.3	67.1	106.2	35.23	35.024	28.915	0.397	0.413	0.35	0.397	33.06
Scenario 4a	1	1	1	1	0	1	1	237.5	69.2	108.7	71.624	72.834	73.427	0.462	0.479	0.416	0	72.63
Scenario 4b	2	1	1	1	0	1	1	237.5	69.2	108.7	71.624	72.834	73.427	0.462	0.479	0.416	0	72.63
Scenario 4c	1	2	1	1	0	1	1	237.5	69.2	108.7	71.624	72.834	73.427	0.462	0.479	0.416	0	72.63

## 6. Results Analysis

The Defense Language Institute is a much smaller pharmacy when compared to the other facilities covered in this study. The biggest differences were the volume of orders processed by the facility and the number of resources that DLI had to process their daily workload. There are only four personnel resources consisting of two pharmacy technicians and two pharmacists. The four personnel have one Receiving Window, one fill station, and one dispensing window to process all of their daily orders. When the authors visited the facility the main concern from the pharmacist in-charge was the facility’s plan to expand to three windows; that is, either having two Receiving Windows or two dispensing windows.

Table 5 shows the results of our discrete-event simulation using the Arena Software suite after completing 100 replications of each scenario. We can note that there was no change in the number of patients processed or their respective process times when a third window is added as a resource either at the receiving end or at the dispensing end of DLI’s current process. DLI has already commenced with renovation of a new

pharmacy that will consist of three windows; however, the results of Scenarios 1 and 3 clearly demonstrate that an increase in window resources will not improve the patient cycle time.

In addition, Scenario 2 attempted to measure the results of decreasing the number of personnel available to service customers. Though the number of customers served by the system did not change significantly, the process times of those served nearly doubled. In addition, the utilization of the remaining personnel increased significantly. Basically, personnel are working harder, potentially, with fewer breaks. Despite the ability to maintain the same level of productivity with fewer workers, the authors cannot recommend a reduction in manpower for the DLI system. Any reduction would have negative results as overall processing times will increase and there would be no replacement personnel during lunch periods, leave periods, etc. This would negatively impact the customer base of the DLI pharmacy as a whole.

What the authors immediately noticed, and further demonstrated in Scenarios 3 and 4, was that DLI was not attempting to decrease the variation of their customer base. Allocating a phone line for calling in all civilian healthcare provider script orders could easily decrease variation if it is automated or updated before/after working hours like the stocking process. This is the biggest variation in the DLI processes and appears to present the greatest savings in the overall patient processing times. Allowing day prior call in of script orders could thus treat all arriving patients the same in terms of how they are handled at the Receiving Window process and eliminate the manual input process currently required by scripts at the Receiving Window. Call a head orders could be retrieved from a messaging system or automatically processed as in the case of the Travis refill pharmacy that will be discussed in Chapter VI. Currently scripts cause the Receiving Window to become a bottleneck, adding up to 2.5 additional minutes for just that process. However, when Scenario 3a and 4a in Table 6 are taken into consideration, the added effort of calling ahead by the patient and the new phone line saves script patients an overall processing time of approximately 9 minutes and a decrease of

approximately 3 minutes for all customers. In addition, Scenarios 3b and 3c and 4b and 4c further emphasize that an increase in the number of windows presents no added value to the customer.

## **7. Conclusions and Recommendations**

The ultimate question for the DLI would be whether a 9-minute reduction in processing time for script patients and a total reduction in processing time of 3 minutes are worth the costs and inconvenience of implementation. Would the customers' overall satisfaction improve at the expense of the script patients?

The Defense Language Institute was modeled to answer two questions: Could they reduce customer flow time by changing their current process configuration and could they reduce waiting time by adding a receiving or dispensing window.

1. There was no difference in processing time or the amount of patients processed by instituting the use of an additional service window for either dispensing or receiving.

2. Due to the size of the facility and the resources utilized in its day-to-day operations, it was not possible to recommend any personnel reductions or increases. The lead pharmacist also requested a modeling study of the value of implementing a third patient service window. The additional window would come in the form of a second Receiving Window or second dispensing window. Based on the information collected at the facility, with the number of patients seen daily and the processing times for all processes within the pharmacy, there would be no added benefit to the patient to add a third window, i.e., there would be no reduction in patient processing time as a result, as seen in Table 5.

3. The researchers did identify one potential area of improvement within the DLI pharmacy that may decrease patient processing times within the system. This was a longer processing time for patients seen by civilian doctors. The civilian scripts take a significantly longer time to process and caused a subsequent bottleneck in the waiting line for all patients. A call-in procedure, as seen Scenarios 3 and 4 should be adopted by

the pharmacy for all script patients that will insure that patient data entered into the computer system prior to their arrival. This would eliminate some of the variability in processing times for the DLI pharmacy affording all patients an identical processing system with no additional steps or processes. This procedural change would yield a total average processing time reduction of 9 minutes for script patients and 3 minutes for all patients.



THIS PAGE INENTIONALLY LEFT BLANK

## VI. TRAVIS AFB PHARMACIES

The main hospital pharmacy at Travis was the second largest facility included in our study and was chosen to be representative of all medium hospitals throughout the military. The main hospital pharmacy employs 15 military pharmacy technicians, seven contractor technicians, one civilian (GS) technician and one civilian (GS) pharmacist. The main hospital pharmacy maintains more than 600 line items of inventory and spends an average of \$2.2 million a month on medications. The facility processes an average of 960 drug orders per day and 21,100 per month. The 24 total employees process an average of 40 orders per day per employee. The personnel cost of the twenty-four employees is a total of \$62,688 per month with a total of 21,100 scripts processed. This would value the cost of processing each script without considering drug costs or other overhead costs at \$2.97 per order.

The Travis AFB has three pharmacies: the main hospital pharmacy, which services POE patients, the Post Exchange annex pharmacy which services script patients, and the call-in refill pharmacy which services refills. Each pharmacy is completely separate with pharmacy personnel and with their own physical location for inventory of pharmaceuticals that provide medicines for daily operations and the hospital's Medical Logistics personnel restock each pharmacy individually.

The Travis hospital pharmacy was designed to service POE patients at the main pharmacy, new script patients at the annex pharmacy, and all refill patients at the annex refill pharmacy. The separation was in an effort to reduce variation at each of the facilities and reduce patient processing time. However, the separation has not been strictly enforced. The annex employs two military pharmacy technicians, two contractor technicians, and two GS pharmacists. The annex maintains more than 340 line items of inventory and the money spent on medications is part of the \$2.2 million spent by the main pharmacy. The facility processes an average of 281 drug orders per day and 7,033 per month. Each of the six employees processes an average of 47 orders each day. The annex processes seven more orders per employee a day than the main pharmacy. The

personnel cost of the six employees total \$21,731 per month with 7,033 scripts processed. This would value the cost of processing each script without considering drug costs or other overhead costs at \$3.08 per order.

**A. VOICE OF THE CUSTOMER**

The survey conducted at the Travis main hospital pharmacy resulted in the participation of 38 patients as seen below in Table 7. Similar to DLI, it was conducted from 0800 to 1200 hours, during peak hours, and 100 percent of pharmacy customers who entered the waiting area were asked to participate. A small number (three) were incapable of participating due to health conditions or handicap. In addition, many of the pharmacy patients never entered the waiting area, presumably because they were hospital employees or worked in close proximity to the hospital, and we were unable to query them for the survey.

Table 7. Travis AFB Main Pharmacy Patient Survey

<b>Service Component</b>			
<b>Army</b>	<b>Navy</b>	<b>AF</b>	<b>CG</b>
6.67%	26.67%	60.00%	6.67%
<b>Status</b>			
<b>A/D</b>	<b>Retired</b>	<b>Dependent</b>	
6.67%	66.67%	26.67%	
<b>Frequency of Visit</b>			
<b>Less than monthly</b>	<b>Greater than monthly</b>	<b>Monthly</b>	
40.00%	33.33%	26.67%	
<b>Distance</b>			
<b>&lt;20 miles</b>	<b>20-50 miles</b>	<b>&gt;50 miles</b>	
46.67%	33.33%	20.00%	
<b>Mode</b>			
<b>Self-transport</b>	<b>Other</b>		
100.00%	0.00%		
<b>Favorability of home delivery</b>			
<b>Favorable</b>	<b>no opinion</b>		
80.00%	20.00%		
<b>Average Wait time</b>			
<b>&lt;30 minutes</b>	<b>30 min to 1 hr</b>	<b>&lt; 1 hr</b>	
33.33%	53.33%	13.33%	
<b>level of statsfaction</b>			
<b>Very Satisfied</b>	<b>Moderately Satisfied</b>	<b>No opinion</b>	
66.67%	26.67%	6.67%	

The second survey conducted was at the Travis AFB annex pharmacy and resulted in the participation of only 15 patients as seen below in Table 8. It was conducted from 1300 to 1500 hours, and 100 percent of pharmacy customers who sat in the waiting area were asked to participate. Many chose not to participate due to pending appointments or a need to use other facilities on the base. Another reason for the low number of participants is the adjacent “call-in” pharmacy; it shares the Base Exchange facility, has almost zero wait time, and enjoys considerably more patronage.

Table 8. Travis AFB Annex Pharmacy Patient Survey

<b>Service Component</b>				
<b>Army</b>	<b>Navy</b>	<b>AF</b>	<b>Marine</b>	<b>Other</b>
	7.89%	13.16%	71.05%	5.26% 2.63%
<b>Status</b>				
<b>A/D</b>	<b>Retired</b>	<b>Dependent</b>		
	36.84%	42.11%	21.05%	
<b>Frequency of Visit</b>				
<b>Less than monthly</b>	<b>Greater than monthly</b>	<b>Monthly</b>		
	52.63%	15.79%	31.58%	
<b>Distance</b>				
<b>&lt;20 miles</b>	<b>20-50 miles</b>	<b>&gt;50 miles</b>		
	81.58%	7.89%	10.53%	
<b>Mode</b>				
<b>Self-transport</b>	<b>Other</b>			
	92.11%	7.89%		
<b>Favorability of home delivery</b>				
<b>Favorable</b>	<b>no opinion</b>			
	92.11%	34.21%		
<b>Average Wait time</b>				
<b>&lt;30 minutes</b>	<b>30 min to 1 hr</b>	<b>&gt; 1 hr</b>		
	65.79%	31.58%	2.63%	
<b>Level of satisfaction</b>				
<b>Very Satisfied</b>	<b>Moderately Satisfied</b>	<b>No opinion</b>		
	78.95%	18.42%	2.63%	

Again, the numbers alone are not remarkable until compared with our other data; however, other themes arose in the “comments” section of the survey that are worthy of mentioning, and must be considered. While numerous patients cited a significant decrease in patient processing times at the Travis AFB hospital, a relatively large number of participants (approximately 20 percent) demonstrated an inability to confidently or accurately manipulate the pharmacy’s automated systems. Customers of the Travis AFB

Exchange pharmacy may submit refill prescriptions via automated telephone, fax, or the Internet; however, the majority of the customers surveyed were retired and elderly, and were seemingly intimidated by these systems. The automated system is only utilized in the refill pharmacy and the facility will be discussed below. In addition, it is important to note that as the percentage of retired personnel increases, so does the amount of distance traveled to use pharmacy services, increasing the need for reliance on the existing automated systems in the refill pharmacy.

## B. PROCESS FLOW MAP

### 1. The Travis Air Force Base Hospital Pharmacy

The main hospital pharmacy's process flow for operations is depicted below in Figure 14.

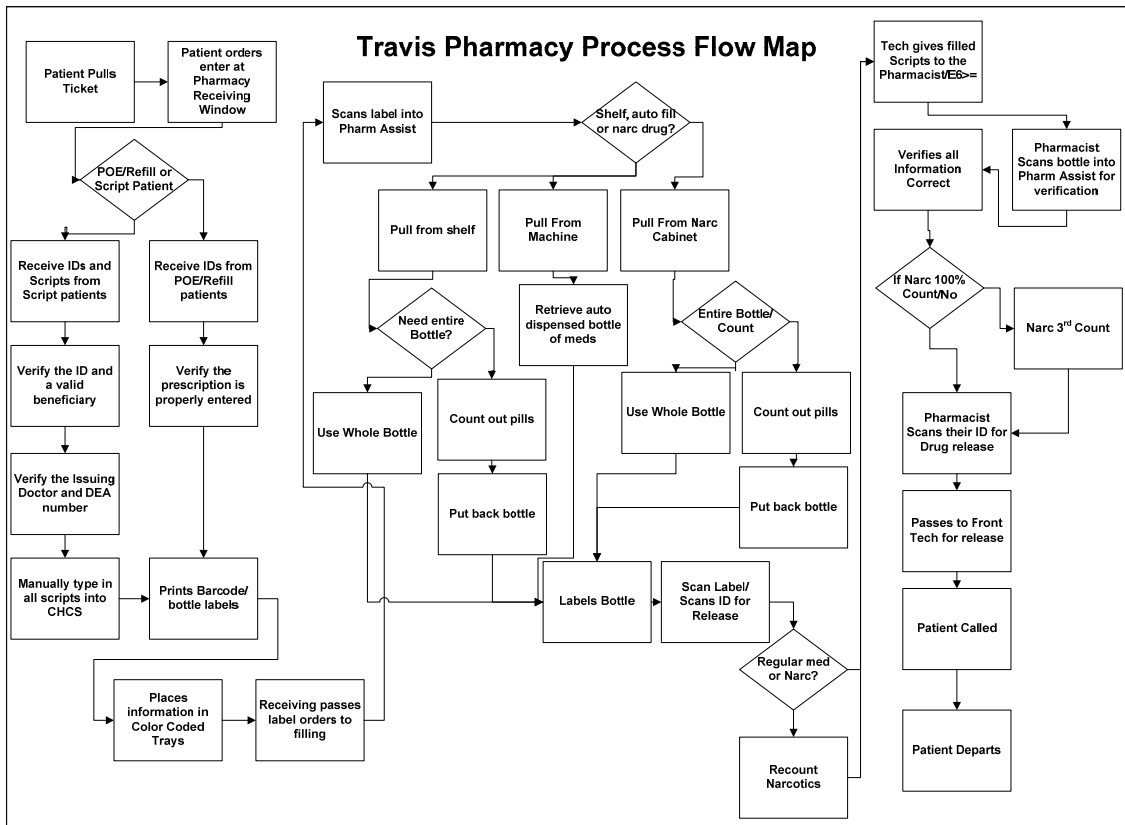

Figure 14. Travis AFB Main Pharmacy Process Flow Map

Figure 14, much like DLI's process flow, depicts each process used within the Main Pharmacy at Travis AFB. We note there is little difference between DLI and the Main Pharmacy with the exception that the Main Pharmacy does not distinguish between the types of entering the system. There is, however, a difference in the methods of filling the prescriptions as this pharmacy places much tighter restrictions on narcotic pharmaceutical and "high risk" medications, presumably due to the significantly larger employee population. As seen in Figure 13, the process flow becomes a common path as; medications are verified, and dispensed.

The process as it is depicted above provides adequate services for the size of the pharmacy operation and the population served. The patient waiting in line to get to the window has no value added to the beneficiary; but is mitigated by an automated ticket dispenser that separates active duty in uniform and all other patients. Each patient pulls a number and wait in the waiting room until their number is called. The time from the moment a number is pulled to the time the patient is called to the Receiving Window ranges from 30 seconds to 1 minute and 30 seconds, depending on the amount of people waiting and whether the patient is in uniform. Patients in uniform receive head-of-the-line privileges.

The total time in the system for patients ranges from 13 minutes to 28 minutes with a mean of 18.5 minutes given the current operational configuration. The wait adds no value to the patient and will be discussed later in this chapter. However, the non-value added processing time could be potentially reduced if the main hospital pharmacy did not take script walk-ins and refills and referred patients to the pharmacy that process refills and walk-in scripts. The added time from these two extra services causes an increased processing time of 1 minute and will be discussed later in the chapter.

A potential congestion in the operations occurred, during the authors' visit to Travis, at the two fill stations within the pharmacy. When the prescription orders are passed back in the process line from the two Receiving Windows they are funneled to two fill stations that are located one behind the other. Time is wasted in determining which station will process what order. The problem is minimal when the process flow is

light, but when orders increase, the first station will be backed up. The discussion on potential fixes for this process will also be discussed later in this chapter.

## 2. The Travis Air Force Base PX Annex Pharmacy

The annex's pharmacy's process flow for operations is depicted below. All pharmacy prescription scripts for civilian healthcare providers and new prescription refill requests are serviced in the annex pharmacy. The pharmacy's annex process flow is below in Figure 15.

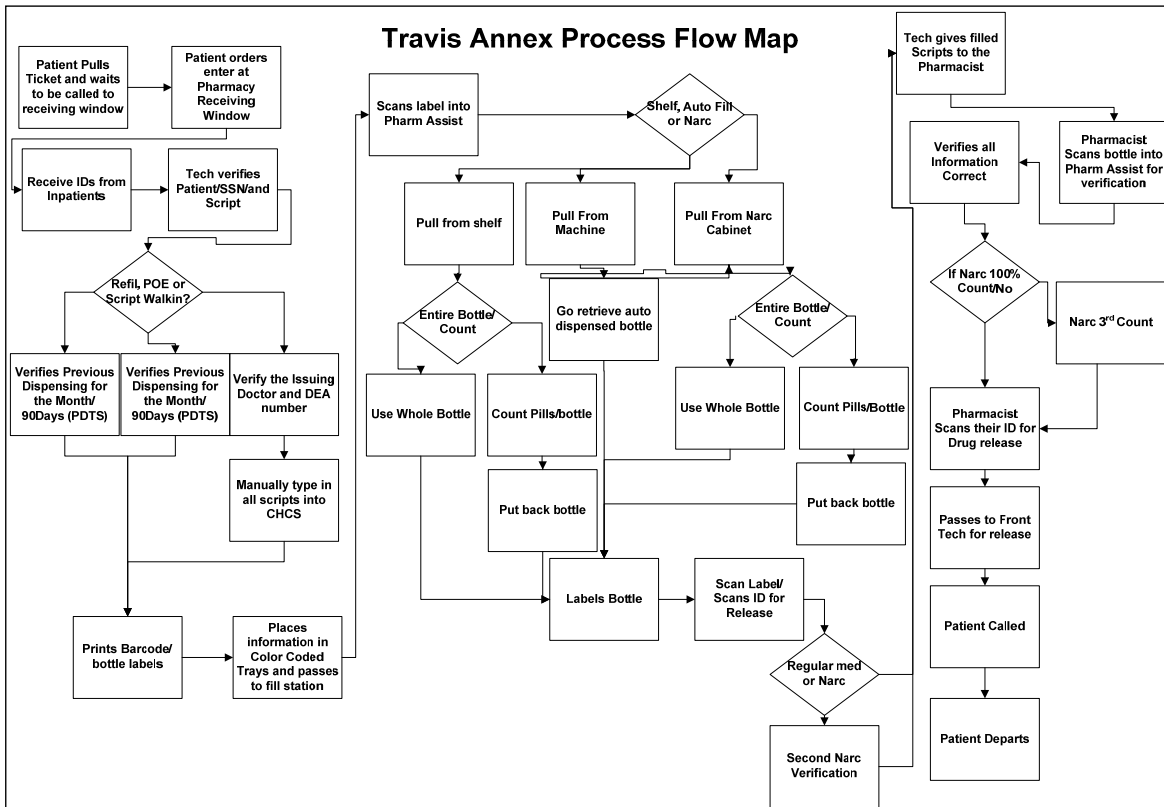

Figure 15. Travis AFB Annex Pharmacy Process Flow Map

Figure 15, depicts much the same as Figure 14 with the most notable variations being among the type of script and the type of medication. Patients who are refilling prescriptions for the first time undergo slightly different processes than those who have previously refilled the same script. Like the depiction in Figure 13, the dispensing method required of each prescription also causes a “split” in the required system processes of each customer. The processes within the Annex are otherwise identical for each customer, however all prescriptions are verified by a pharmacist prior to being dispensed, while only controlled pharmaceuticals are reviewed by the pharmacist at the main pharmacy.

The process as it is depicted above is significantly inhibited by the patient data transaction system (PTDS) verification, new refill requests, and the manual input of all script requests. Both the new scripts and refills are first verified in CHCS for patient eligibility to receive services. The orders from two Receiving Windows then go to a single station that processes new refill and script requests. They have to be first verified in PDTS to ensure that there was no prior dispensing within the past 90 days, after which, the order must be typed into CHCS for every medication requested. The order processing time during this process has no value added to the customer, but cannot be mitigated due to the verification process in PDTS. The station process time could potentially be shortened if an additional station is added to that overall process, thus decreasing the overall process time by increasing capacity.

Upon entry into the annex pharmacy, each patient pulls a number and waits to be called to the Receiving Window. The wait to be called to the Receiving Window ranges from 1 to 3 minutes depending on the amount of people waiting.

The total processing time for patients ranges from 23 minutes to 47 minutes with a mean of 31 minutes given the current operational configuration. The wait also adds no value to the patient and will be discussed later in this chapter. However the non-value added processing time could be reduced if the pharmacy did not take Provider Order Entry (POE) requests or walk-ins for refills and mandated use of the call-in refill process. The entire refill process can be done over the phone via an automated refill request system. The POE orders can be processed at the hospital, and neither should be



processed at the annex pharmacy. The added time from these two extra services causes an increased processing time of approximately 9 minutes and will be discussed later in this chapter.

### 3. Travis Air Force Base Annex Pharmacy (Re-fill Operations)

The annex's pharmacy's refill process flow for operations is depicted below. All pharmacy prescription refills are serviced in the annex pharmacy then delivered to the PX Annex pharmacy for patient pick up. In this process flow, all patient processing time has essentially been cut out, as this pharmacy does not service patients directly. The patient now calls in to place their refill order over an automated phone system. The order is placed one day and the filled order is picked up from the pharmacy annex the following day. The refill pharmacy process flow is seen below in Figure 16. The refill pharmacy has no variation in its operations and has no face to face interaction with patients. The refill pharmacy is not part of the study and is only included here since it is one of the three pharmacies in operation at Travis.

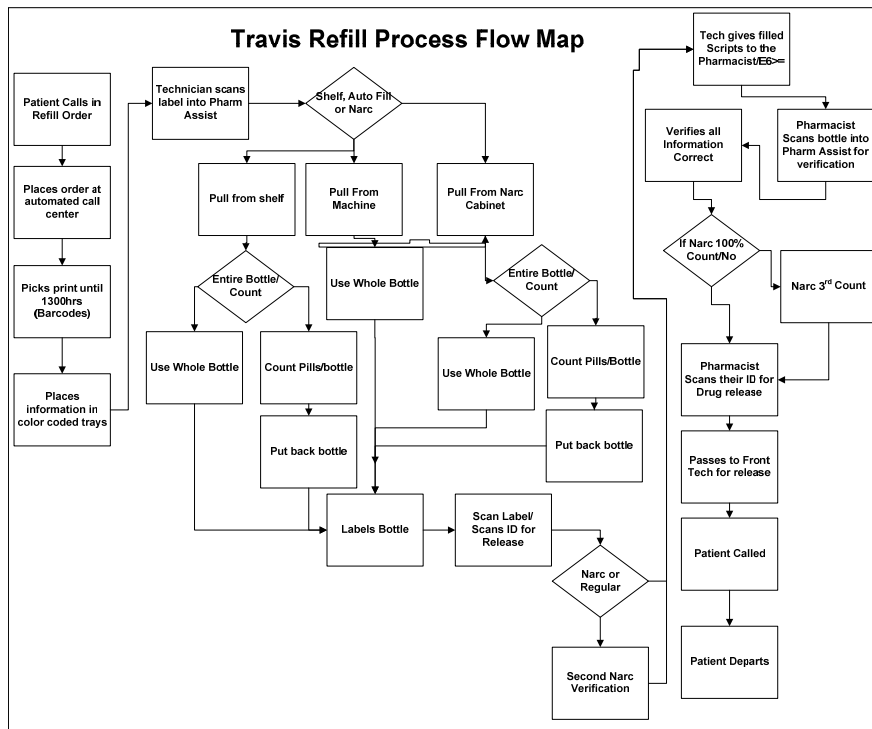

Figure 16. Travis AFB Call-in Process Flow Map

## **C. DATA COLLECTION AND ANALYSIS**

The data collection process was the same as outline above under the DLI collection plan for the process.

The performance metrics and variables had to be identified in relation to the processes within each observed Travis pharmacy. The number of steps, or potential bottlenecks within the overall pharmacy operation is a significant measurement itself. The amount of time necessary to process patients, or their prescriptions, through each step and the number of personnel assigned to the processing of each step must be considered within each metric. Both of Travis' pharmacies were asked what performance metrics do they place upon themselves and all responses were the same. Their metric for success was the same as DLI; a reduced customer processing time.

### **1. The Fishbone Diagram**

Using the fishbone diagram, pharmacy problems that were identified, either by the voice of the customer or observations at the pharmacy, were dissected. The information for both Travis pharmacies is similar to the DLI pharmacy, as seen in Figures 5 and 6. For the Travis main pharmacy, there is also the additional contributing factor of having 24 employees working in a very confined pharmacy workspace. For the Travis annex pharmacy, the problems are the same as those at DLI.

### **2. Collect Data for Determining Defects and Metrics**

The primary data collected from the Travis Air Force pharmacy were the customer processing times from physically observing patients at the pharmacy, patient service volume reports collected for the entire fiscal year 2008, and financial expenditures on medications. However, the primary difference between DLI and Travis was that the collected data was taken from three pharmacy locations on Travis: the main pharmacy, the pharmacy annex, and the refill pharmacy. The volume reports reflected patient data broken into three categories: POE, script patients from civilian healthcare

providers and refill patients. Ideally POE patients were to be seen at the main pharmacy located on the first floor of the hospital. The script patients were to be serviced at the pharmacy annex located at the Base Exchange shopping center. The refill patients were also to be serviced at the annex, but only through a call ahead system where the medication were actually filled on the second floor of the hospital pharmacy and then brought over to the PX Annex the day prior for patient pick up. The main pharmacy, annex (script) pharmacy, and refill pharmacy will be discussed individually below.

**a. Main Pharmacy**

The main pharmacy is designed to service only the POE patients seen at the MTF. The pharmacy services active duty and dependents that have been seen in the military hospital. If the pharmacy conducted operations as designed, it would expedite the processing of orders in the pharmacy by a reduced variation in the orders serviced. The monthly service volume is depicted below with monthly and annual totals and averages in Table 9.

Table 9. Travis AFB Main Pharmacy Patient Volume Report

Month	Script Walkin	Provider Entry	Refil Walkin	Total
October	228	20610	1174	22012
November	130	18033	1170	19333
December	206	17294	1077	18577
January	277	21602	1112	22991
February	208	21565	1002	22775
March	144	21381	824	22349
April	186	23126	1072	24384
May	97	20612	1057	21766
June	248	18161	1002	19411
July	211	17326	1076	18613
August	187	19715	975	20876
September	185	19668	960	20813
Total	2307	239093	12501	253901
Average	192	19924	1042	21158

As seen above, the pharmacy is not only servicing its POE patients but also script and refill patients. The chart depicts that almost eight percent of the patients seen are ones that should be seen at the annex pharmacy. The script and refill patients add to the overall processing time of all patients by injecting variation in the designed work process flow of the main pharmacy. Below in Figure 17 and Table 10 are the patient processing times with August and September forecasted based on a trend analysis of the preceding months.

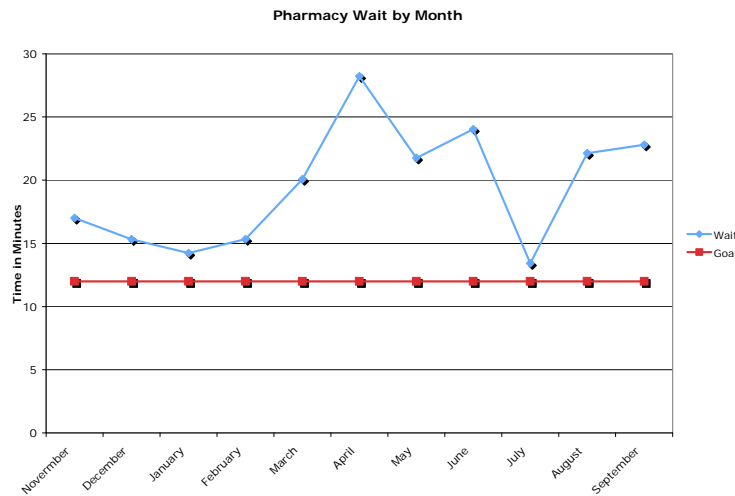

Figure 17. Travis AFB Main Pharmacy Patient Wait times by Month

Table 10. Travis AFB Main Pharmacy Patient Wait times

Month	Wait	Goal	RX
November	17.00	15	19333
December	15.32	15	18577
January	14.23	15	22945
February	15.33	15	22775
March	20.08	15	22349
April	28.22	15	24380
May	21.76	15	21766
June	24.03	15	19411
July	13.42	15	18613
August	22.13	15	21033
September	22.80	15	21015
Average	19.48	12	21109

The previous figures show the monthly average process times, the pharmacy goal of 15 minutes and the average volume of all prescriptions dispensed. The average process time is significantly more than pharmacy’s targeted wait time. An overall reduction in processing time could be reached at the pharmacy in reducing variation by not servicing script and refill patients. A depiction of a possible overall reduction in orders is seen below in Table 11 and Figure 18. Further analysis would be needed to determine the effects of this move on the receiving pharmacy; however, effects would be minimal since the additional workload equates to approximately 1 script patient per hour at the annex pharmacy, and 5 refill patients per hour at the refill pharmacy.

Table 11. Travis AFB Main Pharmacy – Possible Work Reductions

Month	Script Walkin	SWIN + RWIN	Without SWIN and RWIN	Total Scripts
October	0.010357987	0.063692531	0.936307469	22012
November	0.006724254	0.067242539	0.932757461	19333
December	0.011088981	0.069063896	0.930936104	18577
January	0.012048193	0.060414945	0.939585055	22945
February	0.009132821	0.05312843	0.94687157	22775
March	0.006443241	0.0433129	0.9566871	22349
April	0.007627953	0.051591207	0.948408793	24380
May	0.004456492	0.053018469	0.946981531	21766
June	0.012776261	0.064396476	0.935603524	19411
July	0.011336163	0.069145221	0.930854779	18613
August	0.008935215	0.055626343	0.944373657	20876
September	0.008901278	0.055017928	0.944982072	20813
<b>Average</b>				<b>253851</b>

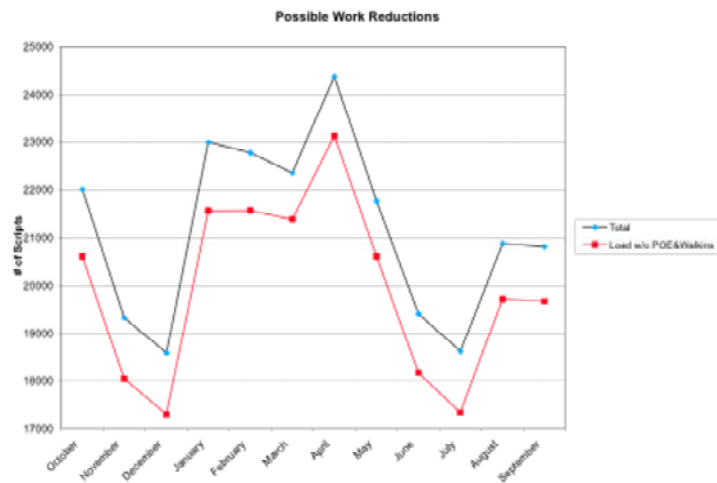

Figure 18. Travis AFB Main Pharmacy – Possible Work Reductions

The charts depict an eight percent reduction in volume if the pharmacy enforces their existing policy of filling refill scripts at the PX annex pharmacy. The average order volume would be reduced from 21,109 to 19,920. The question remains as to how much processing time would be reduced if the pharmacy enforced the policy. A non-linear simulation of the new process will follow later in the Chapter.

The last type of data collected from main Travis pharmacy was their financial expenditures on medications for the entire fiscal year. As stated above for DLI, expenditures are broken down into two categories: credit card purchases and prime vendor purchases. Also stated above, the contract pricing negotiated through DLA from the prime vendor is the best price the DoD can secure for its pharmacies in order to avoid facilities in a certain geographical area from paying higher prices. The contract reduces the need to carry inventory, but the contract does not erase the need of the pharmacy for practicing good inventory management.

As discussed as an issue with DLI, inventory management also appeared to be an issue for Travis' main pharmacy. The medical logistics personnel at the hospital are in charge of all resupply of pharmaceutical lines within all pharmacy areas. In the main pharmacy, they perform a daily scan of pharmaceutical line-item locations by barcode and visually determine how many to reorder based on the available space for more items at that specific location. This process is repeated for all locations on a daily basis. Once all scans are completed for the day, the scanner is cradled at the medical logistics ordering computer and all the reorders are downloaded and processed for that day with the prime vendor. The authors asked the logistics personnel if ordering was performed based on days of supply or economic order quantity based on prior utilization and forecasted use and they replied that it was not. Their ordering was based on need and the daily scanning procedure. Figures 19 and 20 below are the expenditures from the prime vendor and government credit card.

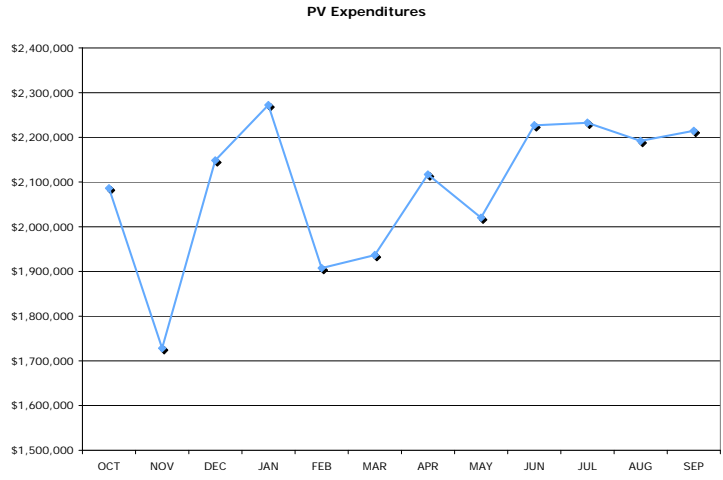

Figure 19. Travis AFB Prime Vendor Expenditures for FY 2008

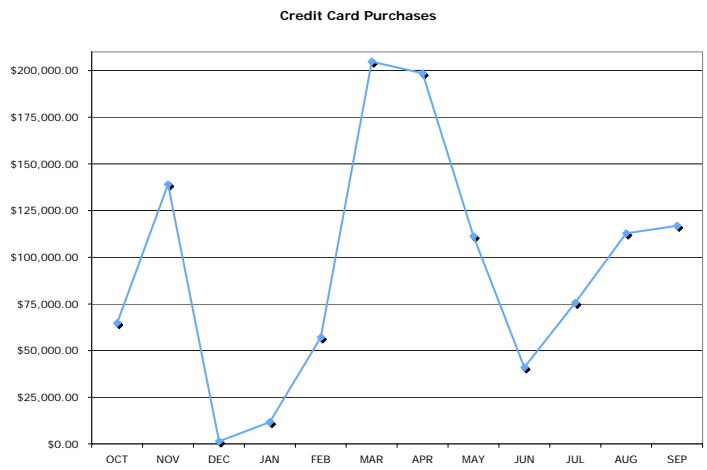

Figure 20. Travis AFB Credit Card Expenditure for FY 2008

As in the case with DLI, neither Travis pharmacy personnel nor the Medical Logistics personnel were aware of exactly how many line items were stocked in the pharmacy. When asked who performed the inventory management of the pharmaceutical lines stocked within the main pharmacy, pharmacy personnel said it was the logistics personnel and logistics personnel said it was the pharmacy personnel performing that operation. This again does not clearly demonstrate that there is any

inventory management within the main pharmacy. The perception is that each believes the other is performing that mission and all of which contributes to a trend for increasing prime vendor and credit card expenditures as seen in Figures 19 and 20.

The pharmaceutical expenditures from the prime vendor and on the government credit card could indicate further that proper inventory management is not being conducted at the Travis main pharmacy. However, a much larger determinate of the problem are the pharmaceutical returns that are credited back to the credit card. Below are the prime vendor and credit card expenditures for fiscal year 2008 that include the pharmaceutical returns for credit in Table 12.

Table 12. Travis AFB Main Pharmacy – Total Expenditures for FY 2008

	PV	CC	Total	Returns
OCT	\$2,086,271.50	\$64,795.63	\$2,151,067.13	-\$13,526.81
NOV	\$1,728,548.54	\$139,005.98	\$1,867,554.52	-\$103,785.79
DEC	\$2,148,571.13	\$1,332.78	\$2,149,903.91	-\$116,095.18
JAN	\$2,272,247.16	\$11,716.03	\$2,283,963.19	-\$151,913.52
FEB	\$1,907,518.24	\$57,063.17	\$1,964,581.41	-\$32,003.90
MAR	\$1,936,848.30	\$204,780.93	\$2,141,629.23	-\$113,573.37
APR	\$2,117,087.14	\$198,500.45	\$2,315,587.59	-\$9,424.02
MAY	\$2,020,312.92	\$111,234.68	\$2,131,547.60	-\$67,359.69
JUN	\$2,226,920.00	\$41,031.72	\$2,267,951.72	-\$61,916.35
JUL	\$2,232,747.09	\$75,611.69	\$2,308,358.78	-\$174,374.21
AUG	\$2,192,021.85	\$112,810.81	\$2,304,832.67	-\$103,229.42
SEP	\$2,214,624.51	\$116,866.00	\$2,331,490.51	-\$106,653.44
Total Spent	\$25,083,718.39	\$1,134,749.87	\$26,218,468.26	-\$1,053,855.70

As depicted above in Table 13, there was more than a million dollars worth of pharmaceuticals turned in to the returns company for money during the fiscal year. Any one of the leading pharmaceutical return companies will take expired or about to be expired pharmaceuticals for a fraction of the cost that they were originally procured. If there were a generous rate of 25 percent given for all Travis returns to the return company, then there would have been over 4.2 million dollars of pharmaceuticals turned in. The pharmaceutical returns show the need for good inventory management and a significant savings to the pharmacy of at least the \$4.2 million worth of turned in pharmaceuticals.



Another potential issue for the pharmacy is the amount of manpower it uses to operate not only the main pharmacy, but also the annex and the refill pharmacy. The main pharmacy utilizes the most personnel with 24 employees that include military, government service (GS) and contract labor. A snapshot of their employees and their approximate annual wages from the 2008 military pay charts are shown below in Table 13.

Table 13. Travis AFB Main Pharmacy – Employee Pay Table

Main Pharmacy							
Worker	Pharm Tech		Cost	Total	Pharmacist		Total
Civilian		1 GS	\$2,700	\$32,398		1 GS10-12	63200
		7 Contractor	\$3,240	\$272,139			
Military		3 E6	\$2,930	\$105,480			
		3 E5	\$2,405	\$86,580			
		3 E4	\$2,047	\$73,692			
		3 E3	\$1,789	\$64,404			
		3 E2	\$1,510	\$54,360			
		23		\$689,053		1	63200
Total Cost							\$752,253
Pharmacy Cost							\$272,139

An Arena modeling simulation and a discussion of worker utilization will be discussed in a following section; however, the authors identified the possibility there was more labor than possibly required. When it is considered that the largest annual cost for a single type of employee is more than \$38,000 for a contractor for a total of more than \$272,000 the question arises as to why not use government service labor or military labor? In either scenario, the cost would be much less than paying for a contractor that can be as high as 25 percent more expensive than GS labor. The Arena simulation later in the chapter will give a better understanding of the pharmacy’s personnel needs based on actual personnel utilization rates. Even if all 24 personnel are required to operate the facility, the question of utilizing cheaper laborers would remain.

**b. Annex Pharmacy**

The annex pharmacy is designed to service only script and initial refill patients seen by civilian healthcare providers. The pharmacy predominately services retirees. As previously stated with the main pharmacy, this separation of services expedites the processing of orders in the pharmacy by a reduced variation in the orders serviced. The monthly service volume is depicted below, in Table 14, and divided into script patients, POE patients, and refill patients.

Table 14. Travis AFB Annex Patient Volume Report

Month	Script Walkin	Provider Entry	Refil Walkin	Total
October	5983	204	807	6994
November	5633	174	561	6368
December	5485	136	468	6089
January	6306	274	565	7145
February	6201	362	566	7129
March	6579	401	693	7673
April	6237	363	724	7324
May	5997	373	904	7274
June	5798	413	733	6944
July	5607	402	814	6823
August	5999	475	819	7293
September	6002	505	843	7351
Totals	71828	4082	8497	84406
Average	5986	340	708	7034

As seen above, the pharmacy is not only servicing its script patients, but also POE and refill patients. The refill and POE patients could have either called in their refill so their order could be serviced from the refill pharmacy or were POE patients that could be serviced from the main pharmacy. The workload indicates that almost 15 percent of the patients seen are ones that should be seen at the main or the refill pharmacy. The POE and refill patients add to the overall processing time of all patients by injecting variation in the designed work process flow of the main pharmacy. Below are the patient processing times with August and September forecasted based on a trend analysis of the preceding months seen in Table 15 and Figure 21. The patient volume report information was obtained from Travis pharmacy personnel from the CHCS system.

Table 15. Travis AFB Annex Patient Processing Times

Month	Wait	RX	Goal
November	29	289	20
December	40	280	20
January	32	291	20
February	30	307	20
March	29	296	20
April	25	304	20
May	23	297	20
June	29	288	20
July	26	269	20
August	47	290	20
September	32	288	20
Average	31	291	20

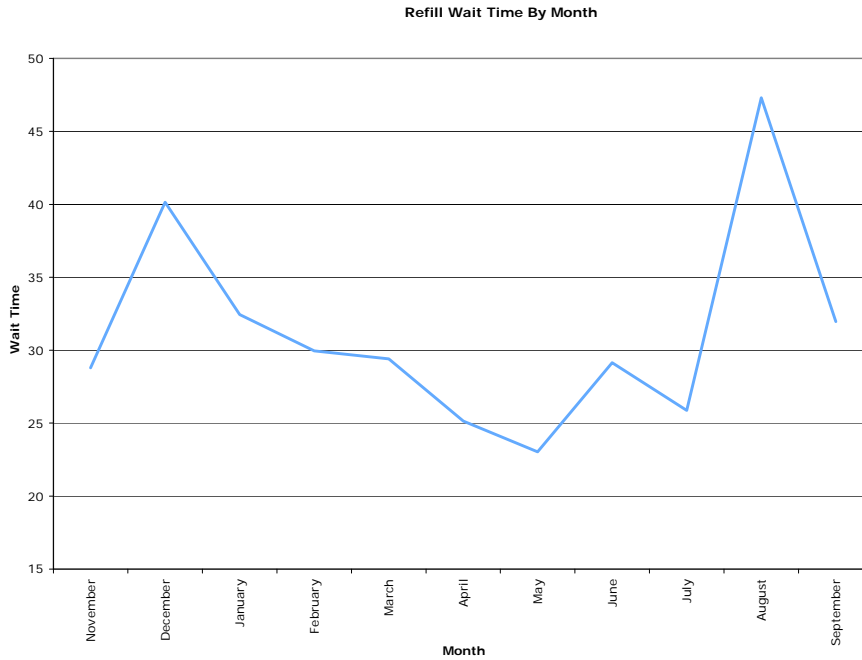

Figure 21. Travis AFB Annex Patient Processing times by Month

The above Table 15 and Figure 21 show the monthly average process times, the pharmacy goal of 20 minutes and the average volume of all the prescriptions dispensed on a daily basis. The average process time is significantly more than the pharmacy’s targeted processing time. An overall reduction in processing time could be

reached at the pharmacy by reducing variation as discussed above. A depiction of a possible overall reduction in orders is below based on an enforced policy of only servicing script patients and initial refill patients at the annex pharmacy in Figure 22. The resulting increase in patients at the annex would only be script patients with a minimal increase of 190 per month.

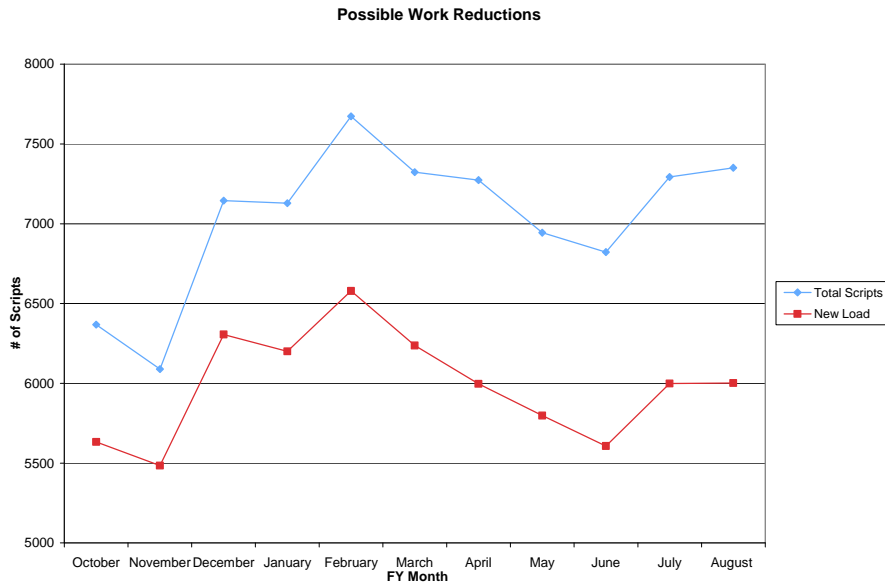

Figure 22. Travis AFB Annex – Possible Work Reductions

Figure 23 depicts a 15 percent reduction in volume if the pharmacy enforces the already in-place policy of only scripts and initial refills being filled at the annex pharmacy. The average order volume would be reduced from 7,037 to 5,984 orders. The question remains as to how much processing time would be reduced if the pharmacy enforced the policy. This question will be modeled later in the chapter.

Another item for discussion in the annex pharmacy was the basic workflow setup. As mentioned above in the annex workflow diagram there is a large bottleneck at the order processing station for the manual input of all scripts. There is only one technician working the station and only one computer assigned for that process.

If another computer and technician were allocated for that process, at least during peak operations, then the average processing time at that station of 5 minutes could feasibly be cut in half.

Manpower was also of concern at the annex pharmacy. It was immediately brought to the authors' attention when the pharmacy's non-commissioned officer-in-charge was asked, "What is your main concern in the pharmacy?" She responded with manpower and not having enough of it to support her mission. A simulation model of the workflow and personnel utilization will occur in the next section, but on the surface, the sergeant's assertion does have merit based on the workload and personnel of each pharmacy. The main pharmacy utilizes 24 personnel compared to the annex's six personnel. The main pharmacy processes an average of 705 orders a day and the annex processes 235 orders a daily. If the number of employees divides the workload, then the annex is handling more of a per-person workload than the main pharmacy at 39 and 29 orders respectively. As outlined earlier with the main pharmacy, below is a chart of personnel and wage expenses at the annex pharmacy in Table 16 and will be discussed later in the chapter as part of personnel utilization in the model.

Table 16. Travis AFB Annex – Employee Pay Table

2nd Floor							
Worker	Pharm Tech		Cost	Total	Pharmacist		Total
Civilian	1	GS	\$2,700	\$32,398	1	GS10-12	63200
	2	Contractor	\$3,240	\$77,754			
Military	1	E5	\$2,405	\$28,860			
	1	E4	\$2,047	\$24,564			
	5			\$163,576	1		63200
						Total Cost	\$226,776

*c. Refill Pharmacy*

The refill pharmacy is designed to service only refill patients that have been set up in the refill teleorder system. The pharmacy is also located at the Post Exchange shopping annex. Unlike Travis' other two pharmacies, the refill pharmacy services all types of patients and is the only pharmacy that adheres to the policy of only

seeing one kind of patient. As stated with the other two pharmacies, this separation of services expedites the processing of orders in the pharmacy by a reduced variation in the orders serviced. The call-in system ensures that only refill patients are serviced at the refill pharmacy.

The refill pharmacy processes an average of 1,200 orders every day. Refill patients must utilize the call-in system to place their order request before 1300 hours the day prior to picking up their medication at the annex. Any order called into the system after 1300 hours will not be processed for a next day pickup, but will be ready the day after. For example, a refill called in at 1400 hours on Wednesday would not be ready for pick up until Friday. However, if it had been placed at 1200 hours on Wednesday, it would be ready for pick up on Thursday.

The second floor of the main pharmacy houses the refill order filling process for the refill annex pharmacy. The second floor is accessible from the main pharmacy by an elevator. Both the main pharmacy and the second floor refill operation houses their own stock of medications to process orders for their daily operation. The refill pharmacy starts downloading orders from the call-in system at 0800 hours in the morning and finishes with their last download of orders at 1300 hours.

Their work process flow, as depicted in Figure 15, is suited for the operational setup of the refill annex and the location of the actual refill process. The daily orders average about 1,200 daily and are processed by just six personnel. Thus, the workload per technician is much higher for the refill operation at 200 orders per person compared to the main pharmacy at 29 and the annex at 39. However, the process does not have to deal with direct patient interaction nor does it have the variation that is permitted at the other two pharmacies. Technicians can focus on filling prescriptions without interruption. What the authors discovered, was that when the variation created by patient interaction was removed from the system, productivity significantly increased. This explains the efficiency in the refill pharmacy and of the mail order program, but is not the focus of our study and the refill pharmacy will not be discussed or modeled any further in the study. The reallocation of refill orders to the annex would amount to an

additional four script per hour and could be easily accommodated. Below is the personnel structure of the refill operation with the associated pay charts seen in Table 17 and will be discussed further below in the modeling section.

Table 17. Travis AFB Refill Pharmacy – Personnel Pay Chart

2nd Floor						
Worker	Pharm Tech	Cost	Total	Pharmacist	Total	
Civilian	1 GS	\$2,553	\$30,639	1 GS10-12	63200	
	2 Contractor	\$3,240	\$77,754			
Military	1 E5	\$2,405	\$28,860			
	1 E4	\$2,047	\$24,564			
	5		\$161,817	1	63200	
					Total Cost	\$225,017

As is the case with all of the pharmacies discussed thus far, the refill pharmacy’s main issue is also inventory management. The main pharmacy has its own stocks of drugs kept for daily operations as does the annex pharmacy and the refill operation. The annex pharmacy is geographically separate from the main hospital and requires its own stocks to perform its daily mission. The annex is also only stocked every other day while the refill and main pharmacies are stocked daily. This would lead one to believe that the inventory at the main and refill pharmacies is turned more quickly than at the annex. A reasonable person would also draw the same conclusion based on the service levels of each pharmacy. However, drawing such conclusion does not take into account the inventory management of the stock level on hand at any of the pharmacies. The pharmaceutical lines of stock for each pharmacy are depicted below and are depicted with lines of stock at shelf locations and machine locations in Table 18.

Table 18. Travis AFB Pharmaceutical Stocked Line-items

Location	Shelf	Machine	Total	%	Refill Frequency	New %	Average Monthly Buys	Cost per Pharm	Number of lines	Average Cost per Line
Annex	200	140	340	0.266	0.5	0.133	\$2,184,872	\$290,178.36	340	\$853.47
Main	320	280	600	0.469	1	0.535		\$1,169,248.10	600	\$1,948.75
Refill	200	140	340	0.266	1	0.332		\$725,445.90	340	\$2,133.66
			1280	1		1		\$2,184,872.35		

Table 18 shows a total of 1,280 lines of pharmaceuticals stocked at all three locations. The main and refill pharmacies that are located in the same area and carry 600 and 340 lines respectively. They are refilled on a daily basis opposed to the annex, which is refilled every other day. Thus the percentage of the total monthly average cost of over \$2 million rest higher on the main and refill pharmacies. This shows an average cost per line item at \$1,948 for the main pharmacy and \$2,133 for the refill pharmacy, but, what if the pharmacy considered a consolidation of the stocks for the main and refill pharmacies? Table 19 depicts of possible cost savings that could be captured by the pharmacy if consolidation of just 100 stocked items were considered. The cost would only be time (one floor separates both pharmacies) and would only be incurred by Medical Logistics personnel. Therefore, there would be no impact on the pharmacy or on patients.

Table 19. Travis AFB Pharmaceutical Stocked Line-item Consolidation

Location	Mean Usage	Safety Level %	Required Stock	Mean Usage	Safety Level %	Required Stock	% Reduction	Cost Savings Per Month
Main	100	0.95	117	200	0.95	224	4%	\$94,734.70
Refill	100	0.95	117					
			234					

Using a Poisson distribution with a mean usage of 100 line items at the main pharmacy and 100 line items at the refill pharmacy at a 95 percent safety stock level it can be seen that the required stock levels at each location would need to be 117 line items at each location. If the pharmacy considered consolidation, the mean usage would be added together to encompass both operations of 200 at a 95 percent safety level and the required stock would only be 224 lines items. There would then be a reduction of 10 line items for a total four percent reduction in inventory. A five percent reduction in inventory may not appear to be a lot, but a monthly savings of \$94,737 leads to an annual saving of over \$1.1 million dollars.



## **D. SIMULATION ANALYSIS**

The purpose of the models is to identify steps within each pharmacy's processes where savings of time and resources could potentially be captured by altering resources and types of customers. A discussion of each pharmacy's simulation model will follow, as above with DLI, and the differences in the models from the DLI model will be discussed for the Travis Main Pharmacy, the Travis Annex Pharmacy, and the Balboa Main Pharmacy.

### **1. Travis AFB Main Pharmacy**

#### ***a. Arena Simulation Model Information and Flow***

In first area of the Travis main pharmacy model three types of drugs come into the pharmacy. There is no deviation from the DLI model (see Figure 8) in this area of the model. The arrival rate of medications had no bearing on the model since dedicated personnel from outside the pharmacy perform daily stocking of shelves, and they keep medications from going to a zero on hand balance.

Like the DLI model, patients enter the pharmacy and are assigned a patient type attribute (POE, Script, and Refill Patient). There was no deviation from the DLI model in this area of the model other than arrival rates (see Figure 9). The arrival rates of the different drugs were modeled as having arrival rates per hour. During pharmacy business hours, patients enter the model every 30 seconds at an exponentially distributed arrival rate. They are further assigned an Attribute of "Patient Type," randomly, based on the historical percentages of patients served by the pharmacy. 94 percent of the patients served at the Travis AFB main pharmacy are POE patients while 5 percent are refills, and 1 percent is new scripts.

The patients/orders then go to one of two Receiving Windows where their orders are processed by receiving technicians. The order flows by entity type up to a pharmacy technician fill station to process the order. There are four fill stations at Travis with four order filling technicians. The filled order will then flow to the pharmacist

station where they are verified for correctness. The Travis system differs from DLI (Figure. 11) in that the pharmacist then passes the filled order to one of four dispensing windows where a technician dispenses the medication to the patient.

***b. Simulation Entities***

Like the DLI pharmacy, the entities of the model were broken down into nine types that consist of three types of patients with corresponding order types in combination with three types of drugs. The three types of patients are: POE patients, script patients, refill patients. The three types of drugs are: machine drugs, shelf drugs, narcotics (narc), and the three types of orders are: POE orders, script orders, and refill orders. They follow through the model similarly to the DLI model with changes mentioned above.

***c. Simulation Resources***

The simulation utilized five resources: a receiving station, a dispensing station, a fill station, a pharmacy technician, a pharmacist, and a stocker. The pharmacy technician set consisted of 23 personnel that will be pulled at random to take orders at the pharmacy window, work at the fill stations and dispense medications. The pharmacist will only process filled orders for review of accuracy. The final set is the stocker set that consists of all personnel that work on a schedule to process arrivals of medication from the pharmaceutical prime vendor; however, the drug arrivals are processed by personnel outside of the pharmacy's purview.

The simulation utilized three types of resources: receiving/dispensing windows, personnel and fill stations. All three resources were utilized on a schedule as previously discussed in the DLI model. It is important to note that the pharmacy is staffed with 24 personnel, each of whom is responsible for more than one process. For example, the in-processing of prescriptions may be accomplished from any of the available personnel at random. Also present in the Travis AFB main pharmacy are six windows that may be used to receive new scripts or dispense filled prescriptions. There

is a stocker set which stocks all medications in the inventory; however, the set is manned with personnel not internal to the pharmacy personnel work structure and does not impact pharmacy operations.

*d. Simulation Processes*

The simulation consists of six Processes. First, patients “Pull a Ticket” upon entering the pharmacy system. This process requires no resources that impact the pharmacy operations and used a Triangular distribution process time of  $TRIA(.5, .75, 1)$  minutes, as observed by the researchers. The second Process, “Receiving Window” requires one technician and one window, and used a Triangular distribution of  $TRIA(.5, 1, 1.5)$  minutes as observed by the authors. Script patients must complete an additional process, “Script In-processing” which simulates the time taken to enter new patient data into the pharmacy computer system. This process requires one technician and one window. “Script In-processing” used a Triangular distribution of  $TRIA(3, 4, 5)$  minutes.

All prescriptions then proceed to the pharmacy “Fill Station” Process that requires one pharmacy technician and one “Fill Station”. They used a Triangular distribution of  $TRIA(1, 1.5, 3)$  minutes as observed by the authors and the pharmacy’s historical data. Next, scripts are reviewed for accuracy by a pharmacist at the “Pharm Station” with a Triangular distribution of  $TRIA(.75, 1, 1.25)$  minutes. Finally the “Pick-up Window” dispenses the filled prescription to the patient with a Triangular distribution process time of  $TRIA(.5, .75, 1)$  minutes.

*e. Simulation Results*

Table 20 illustrates the results of the author’s experimentation with the resources and processes of the Travis AFB main pharmacy. Scenarios 1a-1l demonstrates the results of a decrease in pharmacy technicians and the resulting customer processing times and personnel utilizations. Essentially the first scenario will be analyzing the number of technicians that can be used at Travis main by decreasing the number from 17 pharmacy technicians, on at a time, down to six in total. The idea will

be to see if there is any decrease in the number of patients serviced or an overall increase in patient processing time by performing a personnel decrease. Pharmacy technician utilization will also be looked at to verify how the utilization rate has increased.

Table 20. Travis Main Pharmacy Process Analyzer Results

NAME	CONTROL		RESPONSES					
	PHARM TECH	POE OUT	REFILL OUT	SCRIPT OUT	POE TIME	REFIL L TIME	SCRIPT TIME	P UTIL
Scenario 1a	17	873.48	46.38	10.02	12.61	12.664	16.23	0.12
Scenario 1b	16	873.48	46.38	10.02	12.61	12.664	16.23	0.12
Scenario 1c	15	873.48	46.38	10.02	12.61	12.664	16.23	0.13
Scenario 1d	14	873.48	46.38	10.02	12.61	12.664	16.23	0.14
Scenario 1e	13	873.48	46.38	10.02	12.61	12.664	16.23	0.15
Scenario 1f	12	873.48	46.38	10.02	12.61	12.664	16.23	0.16
Scenario 1g	11	873.48	46.38	10.02	12.61	12.664	16.23	0.18
Scenario 1h	10	873.48	46.38	10.02	12.61	12.664	16.23	0.20
Scenario 1i	9	873.63	46.36	9.93	12.59	12.654	16.22	0.22
Scenario 1j	8	869.99	45.89	9.6	12.15	12.123	15.91	0.25
Scenario 1k	7	874.25	47.33	9	12.58	12.563	16.20	0.28
Scenario 1l	6	859.84	45.46	8.85	17.67	17.925	23.16	0.32
Scenario 2a	17	928.3	---	---	12.01	---	---	0.11
Scenario 2b	16	928.3	---	---	12.01	---	---	0.12
Scenario 2c	15	928.3	---	---	12.01	---	---	0.13
Scenario 2d	14	928.3	---	---	12.01	---	---	0.14
Scenario 2e	13	928.3	---	---	12.01	---	---	0.15
Scenario 2f	12	928.3	---	---	12.01	---	---	0.16
Scenario 2g	11	928.3	---	---	12.01	---	---	0.18
Scenario 2h	10	928.3	---	---	12.01	---	---	0.19
Scenario 2i	9	929.23	---	---	12.10	---	---	0.22
Scenario 2j	8	932.33	---	---	12.75	---	---	0.24
Scenario 2k	7	921.66	---	---	11.80	---	---	0.28
Scenario 2l	6	915.69	---	---	15.80	---	---	0.32

Scenario 2 is the same as scenario 1 without processing any refill or script patients thereby following the standard operating procedure of POE patients using the hospital pharmacy, script patient using the annex pharmacy, and refill patients using the refill annex pharmacy. We will then identify the possible decrease in processing time as well as verify how many technicians can be taken away from the operation before it has a negative effect on the number of patients serviced and the overall processing time.

## **2. Travis AFB Base Exchange Annex Pharmacy**

### ***a. Arena Simulation Model Information and Flow***

In the first area of the Travis annex model, three types of drugs come into the pharmacy. There is no deviation in this area from the Travis main model above. The entities in the annex pharmacy model are broken down into the same nine types that consist of three types of patients, three types of drugs, and three types of orders. The three types of patients are: POE patients, script patients, refill patients. The three types of drugs are: machine drugs, shelf drugs, narcotics (narc), and the three types of orders are: POE orders, script orders, and refill orders. They follow the same flow as the previous model aside from a script processing station that will be discussed below.

Like the Travis main model, patients enter the pharmacy and are assigned a patient type attribute (POE, Script, and Refill Patient). There is also no deviation in this area from the Travis main model above. During pharmacy business hours, patients enter the model every 1.7 minutes at an exponentially distributed arrival rate. 85 percent of the patients served at the Travis AFB annex pharmacy are script patients, 5 percent are POE patients, and 10 percent are refill patients.

The patients/orders go to one of two Receiving Windows where their orders are processed by receiving technicians. The order flows to a script processing station where a technician manually types in each script. The drug labels and order are then passed to a pharmacy technician fill station, with a capacity of two, to process the order. The filled order will then flow to the pharmacist station, with a capacity of two, where they are verified for correctness. The annex system differs from the main pharmacy in that the pharmacist then passes the filled order to one dispensing window where a technician dispenses the medication to the patient.

***b. Simulation Resources***

The simulation utilized seven resources: a receiving station, a dispensing station, a script processing station, a fill station, a pharmacy technician, a pharmacist, and a stocker. The pharmacy is staffed with eight personnel: six are responsible for more than one process, and two pharmacists that perform prescription validation only. There are eight windows (stations) that may be used to receive new scripts or dispense filled prescriptions. Also present in the system is a stocker set that establishes the initial inventory; however, the set does not consist of pharmacy personnel and does not impact operations within the model.

***c. Simulation Processes***

The simulation consists of six Processes. First, patients “Pull a Ticket” upon entering the pharmacy system. This process requires no resources that impact the pharmacy operations and is assigned a Triangular distribution process time of  $TRIA(.5, 1, 1.5)$  minutes, as observed by the researchers. The second Process, “Receiving Window” requires one technician and one window, and used a Triangular distribution of approximately  $TRIA(.5, 1, 1.5)$  minutes as observed by the authors. Script patients must complete an additional process, “Script In-processing” which simulates the time taken to enter new patient data into the pharmacy computer system. This process requires one technician and one window. “Script In-processing” used a Triangular distribution of  $TRIA(2, 2.5, 3)$  minutes.

All prescriptions then proceed to the pharmacy “Fill Station” Process which requires one pharmacy technician and one “Fill Station” and used a Triangular distribution of  $TRIA(1, 2, 3)$  minutes, also as observed by the authors and the pharmacy’s historical data. Next, scripts are reviewed for accuracy by a pharmacist at the “Pharm Station” with a Triangular distribution of  $TRIA(.75, 1.25, 1.5)$  minutes. Finally the “Pick-up Window” dispenses the filled prescription to the patient with a Triangularly distributed process time of  $TRIA(.5, .75, 1)$ .

Also present in the system is a storeroom process that is performed by the hospital's supply section and does not impact regular operations. The process was only modeled to create and maintain the pharmaceutical inventory.

Table 21 illustrates the results of the authors' experiments with the resources and processes of the annex pharmacy. Scenarios 1a-1e demonstrates the results of a decrease in pharmacy technicians, the resulting patient processing times, and personnel utilization. The first scenarios will be analyzing the number of technicians that can be used at the annex by decreasing seven pharmacy technicians down to four in total. The idea will be to see if there is any decrease in the number of patients serviced or an overall increase in patient processing time by decreasing personnel. The utilization of pharmacy technicians will also be verified to help support recommendations for increases or decreases in personnel.

Table 21. Travis Annex Process Analyzer Results

NAME	CONTROLS		RESPONSES							
	PHARM TECH	Script Process	POE OUT	REFILL OUT	SCRIPT OUT	POE TIME	REFILL TIME	SCRIPT TIME	P UTIL	
Scenario 1a	4	1	13.77	27.64	213.02	6.73	6.841	34.756	0.238	
Scenario 1b	5	1	13.71	28.87	212.12	6.393	6.364	34.599	0.191	
Scenario 1c	6	1	12.91	28.72	212.28	6.338	6.317	33.756	0.159	
Scenario 1d	7	1	12.91	28.72	212.28	6.338	6.317	33.756	0.136	
Scenario 1e	8	1	12.91	28.72	212.28	6.338	6.317	33.756	0.119	
Scenario 2a	4	2	13.2	29.13	232.88	10.167	10.583	14.32	0.28	
Scenario 2b	5	2	13.47	30.76	235.85	7.41	7.31	10.464	0.227	
Scenario 2c	6	2	13.09	27.22	237.29	6.695	6.692	9.628	0.189	
Scenario 2d	7	2	13.59	28.6	236.41	6.604	6.633	9.682	0.162	
Scenario 2e	8	2	13.59	28.6	236.41	6.604	6.633	9.682	0.142	

Scenarios 2a-2e are the same as Scenarios 1a-1e, but we will increase the number of script processing stations from one to two. We will then identify the possible decreases in processing time as well as verify how many technicians may be taken away from the operation before it has a negative effect on the number of patients serviced and the overall processing times.

Table 22 illustrates the results of the authors' experiments with the resources and processes of the annex pharmacy if they only serviced script patients. Scenarios 3a-3e are the same as scenarios 1a-1e and 2a-2e, but without processing any refill or POE patients. Scenarios 4a-4e models the standard operating procedure of POE patients using the Travis main pharmacy, script patients using the annex pharmacy, and refill patients using the refill annex pharmacy. We will then identify any possible decrease in process time as well as verify if technicians can added or subtracted from the operation to improve the number of patients serviced and the overall processing time.

Table 22. Travis Annex Process Analyzer Results (Script Only)

NAME	CONTROLS		RESPONSES						
	PHARM TECH	Script Process	POE OUT	REFILL OUT	SCRIPT OUT	POE TIME	REFILL TIME	SCRIPT TIME	P UTIL
Scenario 3a	4	1	0	---	213.25	---	---	34.534	0.212
Scenario 3b	5	1	0	---	209.77	---	---	31.972	0.168
Scenario 3c	6	1	0	---	209.94	---	---	32.073	0.14
Scenario 3d	7	1	0	---	209.94	---	---	32.073	0.12
Scenario 3e	8	1	0	---	209.94	---	---	32.073	0.105
Scenario 4a	4	2	0	---	236.13	---	---	11.926	0.256
Scenario 4b	5	2	0	---	235.03	---	---	9.607	0.204
Scenario 4c	6	2	0	---	235.99	---	---	9.438	0.171
Scenario 4d	7	2	0	---	235.11	---	---	9.491	0.146
Scenario 4e	8	2	0	---	235.11	---	---	9.491	0.128

### 3. Results Analysis

#### a. *Travis Air Force Base Main Pharmacy*

Travis AFB's main pharmacy was the second largest facility studied with more than 900 orders a day and more than 24 employees. The issues for discussion here were the variation in the types of patients serviced and the number of personnel utilized to operate the facility. There were three types of patients: POE, refill and script. Both the refill and the script patients could be seen at the annex where both patients are being



serviced as part of the Travis patient service structure. The second issue was the very low pharmacy technician utilization rate of 12 percent per employee as seen in Table 21, Scenario 1a.

If the main pharmacy chose to service all three types of patients as it currently does, then the options for improvement would be to look at technician utilization and determine if decreasing resources would decrease patients seen or increase total processing time. As depicted in Table 20, lowering resources to down to eight technicians maintains the same level of total patients seen and maintains an average process time of 13 minutes. The eight technicians would also be in addition to a total of six personnel that could be on breaks, leaves, lunches and training raising the technician total to 14. This is a total reduction of nine personnel, from Table 20, that could consist of 1 government service employee and 7 contractors. The total dollar savings would be in excess of \$304,537 per year. Then one military pharmacy technician could possibly be utilized at the pharmacy annex.

If the pharmacy chose to enforce the use of the pharmacy annex for refills and script patients, then there would be a reduction in processing time. The main cause of variation at the main pharmacy is the three types of patients. Reducing the patient type to just POE patients would cause a reduction in total processing time from 14 to 12 minutes on average. This is a reduction of time of 2 minutes as seen in Table 20, Scenario 2j. The reduction of workers leads to no increase in processing time or the amount of patients processed; however, as in the case with the above scenario, using 8 technicians would be optimal due to the improved utilization rate of 25 percent. The shifting of workload to the annex and refill pharmacies would be minimal with an hourly patient increase of 5 and 1 patient respectively.

***b. Travis Air Force Base Annex Pharmacy***

The issues for discussion here were the variation in the types of patients serviced and the number of personnel utilized to operate the facility just as it was the Travis Main pharmacy. There were three types of patients: POE, refill and script. Both

the refill and the POE patients could be seen at the refill annex or the main hospital where both patients are being serviced as part of the Travis patient service structure. The second issue was long processing time of the scripts at the bottleneck script processing station.

In Table 21 Scenarios 1a-1e, we first varied the amount of technicians at the annex incrementally from four to eight technicians and there was no change in the patients serviced or the total processing time. We then increased the script processing stations to two and also incrementally increased the number of technicians starting at four going to eight utilizing four technicians with two script stations, five technicians with two script stations, six technicians with two script stations, seven technicians with two script stations, and eight technicians with two script stations yields processing times of 14, 8, 7, 7, and 7 minutes respectively. The utilization rate of each technician decreased with each increase of a technician; however, the technicians utilized in each scenario do not account for any lunches, leaves or breaks throughout the day. Thus, the best mix of technicians would be to utilize seven technicians with two script processing stations yielding an average processing time of 7 minutes.

If the pharmacy chose to enforce the use of the pharmacy refill annex for refills and the use of the main hospital for POE patients, then there would only be a slight difference in patient processing time. The main cause of variation at the annex pharmacy is the three types of patients. Reducing the patient type to just script patients would actually cause an increase in total processing time from 7 to 9 minutes on average. Thus, there is no reduction in processing time as seen in Table 22. The annex should service all three types of patients and implement the scenario above utilizing two technicians with two script-processing stations.

***c. Travis Air Force Base Refill Pharmacy***

The Travis Refill Pharmacy was not modeled as part of the analysis. The refill pharmacy has no variation in its process since it services only refills. The refill facility employees six technicians and processes over 1,200 scripts a day. This averages

200 scripts per technician and was the best script processing ratio of any area studied. If the SOPs were followed and all refills went to the Refill Pharmacy, the increase in workload would average only a few additional scripts per hour, and could be easily accommodated by the current refill pharmacy personnel.

## **E. CONCLUSIONS AND RECOMMENDATIONS**

The Travis Main Pharmacy was modeled to determine the possibility of reducing patient processing time and the number of personnel operating the pharmacy without decreasing the patients serviced. In the first scenario Travis Main should reduce their personnel operating the pharmacy by nine pharmacy technicians. This reduction in personnel would enable considerable cost savings every year without adding any additional processing time for the patient. If the pharmacy chose to enforce the use of the annex and refill pharmacies for all script and refill patients then the Main pharmacy would not only enjoy the cost saving of reducing nine personnel, but would also see a total reduction in patient processing time of approximately 7 minutes. The main hospital pharmacy should enforce the use of the latter two facilities for script and refill patients as well as reduce manning in the pharmacy to enjoy both cost savings as well as a significant reduction in patient processing time.

The Travis Annex Pharmacy was also modeled to determine if there could be any reduction in pharmacy personnel and explore ways to improve their long patient processing time. It was not possible to reduce personnel in any of the scenarios modeled for the annex pharmacy in order to maintain the current level of services provided. In scenario 1 the number of pharmacy technicians were both decreased and increased as well as an increase of one in the script processing stations. The optimal mix of technicians was seven personnel and two script processing stations. This mix yielded a reduction of patient processing time of more than an hour to approximately 7 minutes. Unlike the main pharmacy, it would not be recommended to enforce the use of the main pharmacy for POE patients nor the use of the refill pharmacy for refill patients. This enforcement would provide no improvement to the total patient processing time. Thus

the annex pharmacy should service patients as it currently operates, increase their script processing stations by one to a total of two, and increase their technician personnel by one for a total of seven.

**1. The Travis AFB Main Pharmacy**

a. There were several areas identified at the main pharmacy during the study that warranted closer examination: patient processing time and total personnel working at the facility. The total patient processing time was averaging 20 minutes while the stated goal of the leadership was to have an average processing time of 15 minutes. As discussed in Section C of Chapter IV, the main pharmacy is servicing script and refill patients who could otherwise be seen at the annex and annex refill pharmacies aboard the same installation. If the use of the correct pharmacy were mandated then there would be a total processing time reduction to the patients at the main pharmacy of more than 2 minutes for a total processing time of 12 minutes.

b. The second issue was the amount of number of personnel utilized by the main pharmacy. The 24 total personnel used to operate the facility appeared to be significantly high early in authors' observation. That hypothesis was confirmed during the modeling phase of this project when the technician utilization rate for the daily processes was shown to be 12 percent. A decrease in pharmacy technician resources of eight personnel, or 14 on the payroll, yielded no increased processing time for the patient and did not decrease the volume of patients serviced. The reduction in personnel yielded a savings in personnel costs of \$304,537 per year. These figures bear no consideration for operational tempo, training and military obligations outside the hospital that would otherwise create a manpower shortage within the pharmacy. That said, issues one and issue two could potentially be combined for a processing time savings to the patient of more than 8 minutes and a dollar savings to the taxpayer in excess of \$300,000 annually.

c. Another area of concern for the authors rests solely in the realm of inventory management. Travis AFB Hospital receives \$100,000 monthly from a vendor for returned pharmaceuticals that are expired, or nearing their usable shelf life. This

number is significant, as this is approximately 20-25 percent of the original medication cost. Upon observation it was unclear whether the pharmacy was utilizing any system for managing inventory that was not narcotic or high risk, such as First In First Out (FIFO). More simply put, some medications were simply placed upon stock shelves without regard to the expiration date. What's more, the pharmacy receives two re-supply deliveries per day from their prime vendor. The use of an inventory management system couple with the ability to replenish potential stock-outs should virtually eliminate expired returns.

## **2. The Travis AFB Annex Pharmacy**

a. The biggest issue that arose from the study of the annex pharmacy was the significant patient processing time. The total patient processing time was averaging from 45 minutes to 1 hour and the stated goal of the leadership was to attain a goal of 20 minutes. As discussed in Section C of Chapter IV, the annex pharmacy is servicing POE and refill patients when they could normally be seen at the main hospital and annex refill pharmacies. If the use of the correct pharmacy were mandated then there would actually be an increase in patient processing time given the processing times and the constraints of the annex pharmacy.

b. The second issue was the number of personnel utilized by the annex pharmacy. There was a large backlog of orders in the workflow process leaving the Receiving Window to be processed at the manual script processing station. The bottleneck at the script-processing center could not be overcome without adding additional resources in the form of a technician and a computer station. The additional resources could feasibly be taken from the main pharmacy to institute the new script processing station. In total, no personnel reductions could be made in the annex without a negative impact on customer service. There is an actual need for two personnel and the additional script processing center in order to attain the leadership's stated goal of at least a 20 minute processing time. However, if the pharmacy implemented the recommendations of two script-processing centers with a total of eight personnel, the patients would enjoy a total processing time of just over 7 minutes.

c. In addition and as previously noted in the analysis, the authors' survey revealed that despite the ability of patients to "call-in" or "fax" refill scripts beforehand, many customers either choose not to do so or are unable to do due to the complexity of the system. A technician or volunteer assigned to assist these customers directly would also serve to alleviate this aforementioned backlog, thus decreasing overall processing times.

THIS PAGE INENTIONALLY LEFT BLANK

## **VII. SAN DIEGO NAVAL BASE PHARMACY (BALBOA)**

The Balboa pharmacy employs more than 24 personnel to do direct day-to-day outpatient operations. Their employee positions consist of six pharmacy technicians that are utilized as logistics personnel, six pharmacists, and twelve pharmacy technicians that provide face-to-face services to the patients. Balboa was not as forthcoming with their personnel information as the other facilities as to the amount of contractors versus GS employees and military that work within the pharmacy. The authors used the figure of 24 employees for purposes of the study from information attained through conversations with the deputy commander of the facility; however six of those employees are only utilized for stocking medication. Thus, Balboa employed six contractor technicians, three military, three GS technicians, and three GS pharmacists. The pharmacy maintains more than 2,500 line items of inventory and the money spent on medications averages more than \$2.1 million per month. The facility processes an average of 1,550 drug orders per day and more than 37,000 per month. Each of the 18 employees processes an average of 86 orders per day and was the most processed per employee by a pharmacy with direct patient interaction. The personnel cost of the 24 employees is a total of \$66,519 per month with a total of 37,000 scripts processed. This would value the cost of processing each script without considering drug costs or other overhead costs at \$1.79 per order.

The Balboa pharmacy is designed to service POE and script patients. These two types of patients are further managed by the pharmacy as active duty, staff and patients requesting non-formulary medications. No refill patients are physically seen at the registration window of the pharmacy. All refills are sent to the VA consolidated mail outpatient pharmacy (CMOP) mail order refill facility. Additionally, 85 percent of refills are mailed and 15 percent are picked up at other locations to include branch clinics and civilian pharmacies. The CMOP program processes an average of 50,000 line-item requests for medications a month servicing approximately 20,000 patients. Thus, the mail order program also reduces variation in the Balboa main pharmacy processing system. However, is it a good deal?



**A. VOICE OF THE CUSTOMER**

The Balboa Medical Center Pharmacy did not permit a survey of their patients to be conducted for inclusion in this project.

**B. PROCESS FLOW MAP**

The Balboa pharmacy has two pharmacies: the main hospital pharmacy services POE orders as well as civilian script orders, and the refill pharmacy that is serviced entirely by the CMOP that is outsourced to the Department of Veterans' Affairs. The main pharmacy has its own inventory of pharmaceuticals that provide medicines for daily operations and are restocked by the pharmacy's supply technicians. The main hospital pharmacy's process flow for daily operations is depicted below in Figure 23.

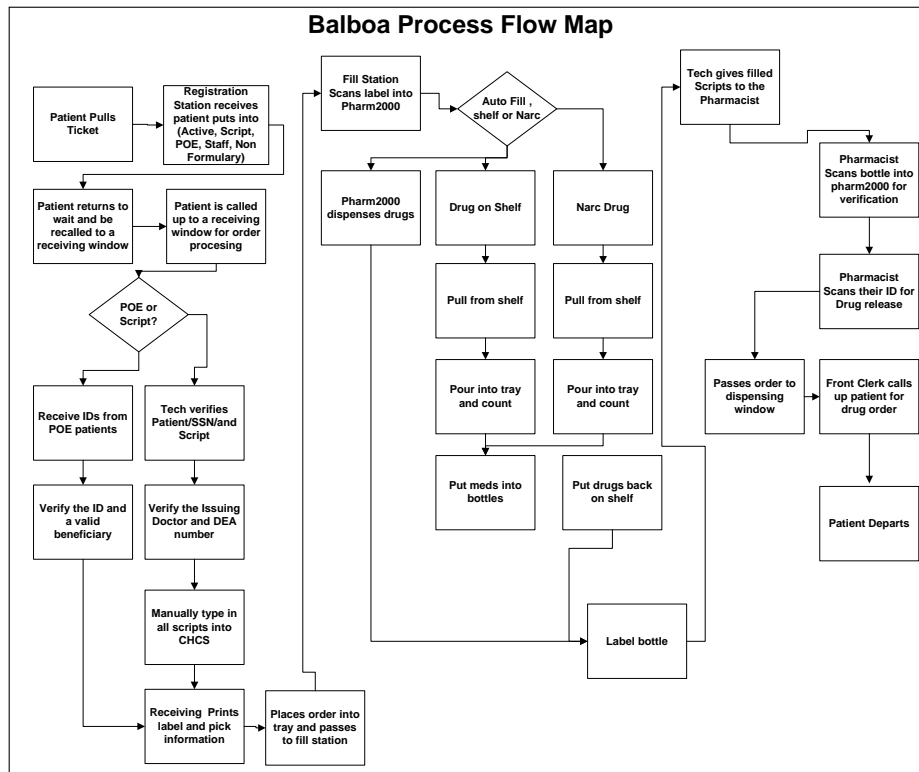

Figure 23. Balboa Naval Hospital Pharmacy Process Flow Map

The process as it is depicted above is setup to serve as a pharmacy for a large medical center and services only POE and script patients. Both types of patients enter the system by pulling an electronic number then waiting to be called to one of eight registration windows. The registration windows perform three functions: registration, receiving scripts, and dispensing medications. The purpose of the administration window is to categorize patients into one of five groups: active duty, script, POE, staff and non-formulary request. The authors observed that time from a pulled number to the patient being called to the registration window ranged from 30 seconds to one minute depending on the number of people waiting. Patients in uniform receive no special privileges, and the registration process can last between three to five minutes depending on the patient type and the number of prescriptions in their order. The registration processing times were provided to the authors by the deputy pharmacist and observed for one patient during the authors' visit to the Balboa pharmacy.

When the patient enters the system, an arrival time is recorded for the patient in a queue management software platform, called Q-flow, starting from the time of the pulled ticket. While the patient waits in the waiting room, the registration clerk prints the drug order and labels to a printer next to the drug pull station. There are two technicians working the station that continuously fill patient orders. The prescription orders are pulled for three varieties of drugs: narcotics from the vault, drugs from the shelf, and automatically dispensed drugs from the Pharmacy 2000 dispensing cabinet. Depending on the type of drug needed for the order and the number of drugs in an order, the fill time can last between 1 to 5 minutes.

Once the pharmacy technician has finished filling the order it is passed to the pharmacist station. There, a pharmacist is in charge of verifying every order to ensure it has been filled correctly. The time associated with this quality control process can vary depending on the number of drugs being dispensed, if there is a narcotic involved, and if the medication is a pediatric drug. This quality control process normally takes between 1 to 3 minutes.

The registration clerk is the final process in dispensing medications. Once the pharmacist is finished with validating the order, it is passed to the registration clerk for issuance. The clerk will call up the patient by their ticket number, give the order to the patient, and close out the patient processing time in Q-flow.

The average total processing time for patients ranged from 16 minutes to 24 minutes with a mean of just over 20 minutes given the current operational configuration. The wait adds no value to the patient and will be discussed later in this chapter. The hospital changed its operational configuration when it started using the Consolidated Mail Order Pharmacy (CMOP) program to fill prescriptions in 2002. CMOP handles all 80 percent of all refills to be mailed, and the hospital mails five percent of refills that cannot be serviced by CMOP due to the type of medication. The remaining 15 percent of refills are handled at other military pharmacy locations throughout the San Diego area (these outlying clinic pharmacies were not part of the study). The CMOP program handles an average of 50,000 refills a month and the Balboa pharmacy is charged a flat rate processing fee of \$2.85 per refill plus the cost of the medication to process refills.

One potential bottleneck in the operation occurs at the fill stations within the pharmacy. When the prescription orders are passed back from the registration window, they feed from up to eight registration windows into one fill process line consisting of two fill stations. These two fill stations must use a single printer; therefore there is a potential for a large backlog of orders into a single printer and only two workers filling prescriptions from eight registration windows. This is not a problem when patient flow is light, but when orders increase, the fill station could become inundated. The discussion on potential fixes for this process will also be discussed later in this chapter.

### **C. DATA COLLECTION AND ANALYSIS**

The data collection process was the same as outlined above under the Travis AFB collection plan for the process. The performance metrics and variables had to be identified in relation to the processes within the Balboa pharmacy. The number of steps, or potential bottlenecks within the overall pharmacy operation is a significant

measurement itself. The amount of time necessary to process patients, or their prescriptions, through each step and the number of personnel assigned to the processing of each step must be considered within each metric. The Balboa pharmacy was asked what performance metrics do they place upon themselves and all responses were the same. Their metric for success was also the same as Travis; a reduced patient processing time.

## **1. The Fishbone Diagram Analysis**

Using the fishbone diagram, pharmacy problems that were identified by the voice of the customer and observations at the pharmacy were dissected. The information provided below is similar to both Travis pharmacies and any differences will be discussed below.

The problems as outlined in the Figure 5 and 6, like Travis and all the pharmacies in this study are the excessive costs and patient processing times that occur in pharmacy operations and for the patient.

## **2. Collect Data for Determining Defects and Metrics**

The cost of utilizing CMOP is \$2.85 per drug order plus the cost of the drug and is paid by the Balboa pharmacy. The Balboa pharmacy averages 1,600 medication orders a day for a total of 40,000 for the month, and they also spend an average of \$2 million on drugs a month. This would give an average cost for drugs of \$50 per order. If the average of 50,000 line-time requests processed at CMOP is considered plus a cost per script of \$50, then the possible total monthly cost to the government is \$2.5 million and \$30 million annually. The question could be asked, was it a good deal to send all refills to CMOP? Couple this question with the fact that the Balboa pharmacy has not reduced any personnel since moving refills to CMOP, but has actually hired more personnel since implementing CMOP in 2002 and the question would get even further complicated. This issue will be further analyzed in the analysis portion of the study, but even if CMOP is the cheapest method for the government to provide refill medications to patients,

outsourcing this benefit should have been followed with a personnel utilization study to properly determine the optimum manning needs of the pharmacy after the change in operations. If CMOP is handling 50,000 scripts a month, it would equate to approximately 2,000 scripts a day while the hospital handles 1,600 scripts a day. This could mean that the hospital reduced its workload by at least half with no subsequent reduction in labor. Regardless of this initial analysis, mere cost differentials ignore the fact that the alternatives may have different impact on mission value (Kang, 2005). Just because a new process may appear to be cheaper on the surface a new process should be appropriately assigned costs and weighed for potential benefits.

The daily average of orders/scripts processed at the Balboa pharmacy is 1,600. This average is significantly higher when compared to DLI and Travis AFB at 270 and 960 respectively if refills are not considered in their operations. However, the study only looked at Balboa hospital main pharmacy operations and not the 11 other supporting branch clinics in the San Diego Naval Base supported area. Other than the PX annex, Travis did not have any outlying or supporting clinics. If DLI could be used as a typical medical clinic servicing an average of 225 orders a day then collectively Balboa services over 4,300 scripts daily. Below is Table 23 and it outlays the patient volume by type of customer serviced at Balboa. All patient volume information was reported to the authors from the pharmacy commander.

Table 23. Balboa Medical Center Patient Volume Report

Month	POE	AVG POE	Script	AVG Script	Avg Prescriptions	Avg Patients
Sep 07	5957	314	1186	62	1517	458
Oct 07	5423	285	903	48	1504	347
Nov 07	6270	314	1057	53	1558	422
Dec 07	6594	330	1027	51	1471	455
Jan 08	8894	424	1474	70	1790	596
Feb 08	8643	432	1329	66	1755	601
Mar 08	9040	452	1320	66	1691	624
Apr 08	9204	418	1416	64	1748	589
May 08	7516	358	1120	53	1608	490
Jun 08	8353	398	1234	59	1558	534
Jul 08	8326	378	1245	57	1518	519
Aug 08	8005	381	1256	60	1587	529
Total	92225	4483	14567	710	19304	6165
Tot/AVG	7685	374	1214	59	1609	514

Below are the wait times by patient type for the year seen in Table 24. Patient wait time is terminology used by the Balboa pharmacy, but wait time is actually a patients' total time in the system.

Table 24. Balboa Medical Center Patient Wait times

Month	Active Avg Wait	POE Avg Wait	Script Avg Wait	Weighted Av Wait	Registration WT	Total Wait
Aug 07	13.50	17.80	20.93	17.34		17.34
Sep 07	15.17	16.86	20.12	16.87		16.87
Oct 07	16.53	15.52	19.17	16.06		16.06
Nov 07	14.76	16.74	19.64	16.74		16.74
Dec 07	14.61	17.20	18.83	16.99		16.99
Jan 08	14.00	17.68	19.04	17.18	6.00	23.18
Feb 08	16.04	20.83	23.28	20.32	5.45	23.59
Mar 08	14.75	17.49	20.79	17.37	5.70	23.07
Apr 08	13.03	16.57	18.53	16.15	4.82	20.97
May 08	13.87	16.85	18.29	16.54	6.11	22.65
Jun 08	13.87	17.37	20.16	17.15	6.90	24.05
Jul 08	12.65	15.17	17.97	15.05	4.07	19.12
Aug 08	13.74	16.93	18.17	16.53	5.95	22.48
AVG	14.35	17.16	19.61	17.04	5.62	20.24

All patients at Balboa are treated the same when they enter the hospital pharmacy and are not assigned any special priority over one another. However, it can be misleading to just look at active duty patients and POE patients separately. The hospital separates these patients in Q-flow for tracking purposes, but they are essentially the same type of patient. The processing time variation could be explained by taking for granted that active duty military are generally healthier than dependants based on their military life-style and thus requiring fewer scripts per patient leading to less of a wait. The higher process time for script patients could work the opposite as well as the need for each script to be manually typed into the CHCS system to setup the order for dispensing.

There was also an overall increase to total patient processing time around December 2007. The Q-flow system that is used during the patient registration process appears to have added an average of an additional 6 minutes to the overall patient processing time. The other two pharmacies in the study do not utilize this system for queuing and tracking patients. The benefits of using this system are the ability to track each type of patient their category's processing time and exactly how many patients are receiving scripts; however the downside is that the patients must wait an average of six

additional minutes for their medication while their information is entered into Q-flow. The other two pharmacies could only show total script volume by patient type and were tracking patient processing times off-line to prevent artificial wait time being added to the patient's wait for their medication. Below are the patient processing times by month for the current Balboa system utilizing Q-flow and the process times for the same system not using Q-flow.

The depiction of Figure 24 demonstrates patient processing time with Q-flow. The weighted average processing time below in Figure 25 shows what the processing time would be without Q-flow and directly to the right of the column is the additional time added for the registration process. The stated goal of the Balboa pharmacy was to have a reduced total processing time and have that time at or below 20 minutes. By not utilizing the Q-flow program, which adds no value to the patient, the processing time for the year fell below the 20-minute goal on the chart and would have an overall average of 17 minutes per patient for the year.

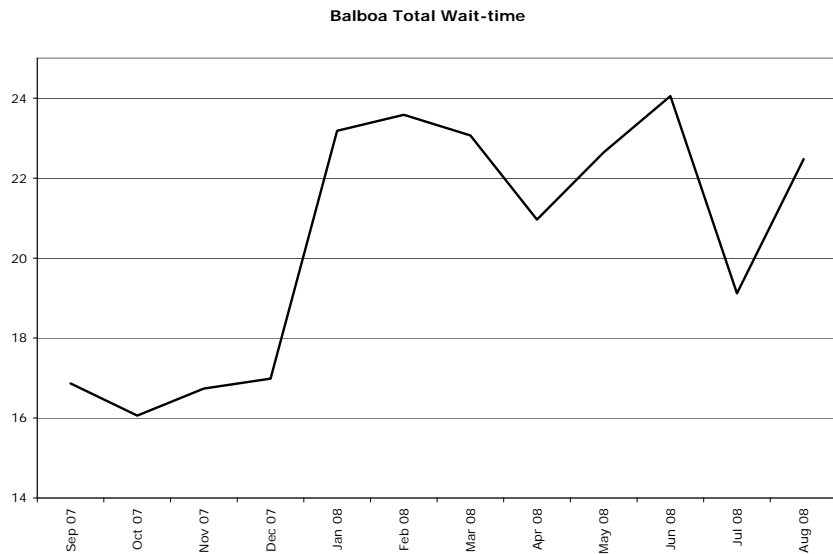

Figure 24. Balboa – Monthly Patient Processing Times

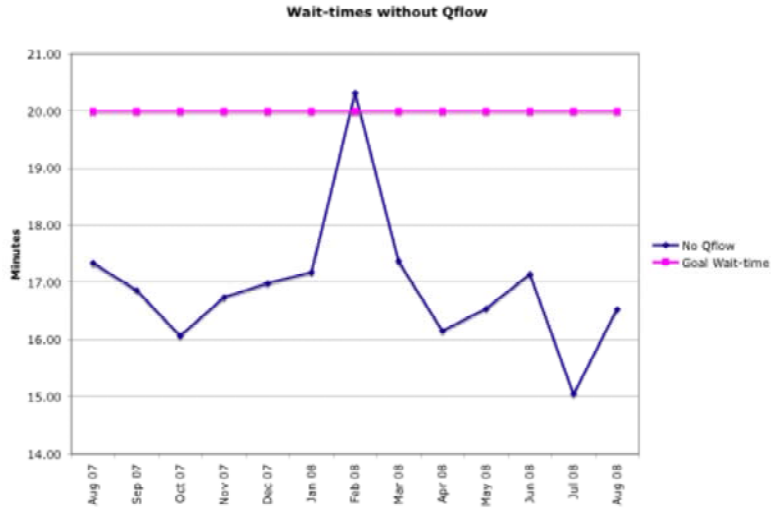

Figure 25. Balboa – Monthly Patient Processing Times without Q-flow

Thus, the potential issue at the Balboa pharmacy, like the other two facilities, was the issue of inventory management. Balboa, Travis, and DLI all utilize the same prime vendor for pharmaceutical resupply. The vendor provides next-day delivery to the pharmacy. Balboa stocks approximately three thousand line items of pharmaceuticals that are restocked by pharmacy technicians daily. The stock services a daily workload of scripts of only 1,600. The question of inventory management was quickly addressed with Balboa given a script workload that was half the size of the inventory. Balboa’s prime vendor expenditures are seen below in Table 25.

Table 25. Balboa Medical Center Total Expenditures for FY 08

Month	Prime Vendor
Sep 07	\$ 1,899,936.96
Oct 07	\$ 1,439,022.29
Nov 07	\$ 1,748,781.81
Dec 07	\$ 1,884,722.19
Jan 08	\$ 2,471,320.33
Feb 08	\$ 2,491,480.48
Mar 08	\$ 2,587,633.43
Apr 08	\$ 2,439,994.19
May 08	\$ 2,030,619.30
Jun 08	\$ 2,214,951.93
Jul 08	\$ 2,150,065.91
Aug 08	\$ 2,193,637.24
Average	\$ 2,129,347.17



The above Table 25 depicts Balboa prime vendor expenditures. Balboa essentially spends the same amount on pharmaceuticals as Travis, is able to service 60 percent more scripts, but stocks far more lines of pharmaceuticals at more than 2,500 items. Balboa, Travis and DLI all order using DMLSS, however the main issue with DMLSS is its ability to manage inventory and establish an economic order quantity for reordering through the prime vendor. DMLSS will track historical orders placed for a particular drug, but drugs are not dispensed in the unit of issue in which they are purchased. Thus, all three facilities attempt to manage inventory off-line through some pencil to paper process. As already stated, Balboa appears to be getting more scripts out of their \$2 million a month than Travis, but still falls short on inventory management when it is considered that they carry 2,500+ lines of inventory and are resupplied daily from the prime vendor. Inventory management is a key factor for running any fiscally responsible supply based organization and must be addressed in the pharmacy in order to capture true cost savings

An Arena modeling simulation and a discussion of worker utilization will be outlined later in a follow on section; however, as in the case with Travis, the authors identified the possibility that there was more labor than required.

#### **D. SIMULATION ANALYSIS**

The purpose of the models is to identify steps within each pharmacy's processes where savings of time and resources could potentially be captured by altering resources and types of customers. A discussion of the pharmacy's simulation model will follow, as above, and the differences in the models from the DLI model will be discussed as they were for the Travis Main Pharmacy and the Travis Annex Pharmacy in the previous Chapter.

##### **1. Arena Simulation Model Information and Flow**

Like the DLI pharmacy, the entities in the Balboa pharmacy model were separated into nine types that consist of three types of patients, three types of drugs, and

three types of orders. The three types of patients are: POE patients, script patients, refill patients. The three types of drugs are: machine drugs, shelf drugs, narcotics (narc), and the three types of orders are: POE orders and script orders. They follow the same flow as the DLI model.

In the first area of the Balboa model three types of drugs enter the pharmacy system. There was no deviation from the DLI model (see Figure 8). The arrival rate of medications had no bearing on the model since dedicated supply personnel from another department perform daily stocking of shelves and do not impact the operations depicted within the model.

Like the DLI model, patients enter the pharmacy and are assigned a patient type attribute (POE and Script). There was also no deviation from the DLI model other than arrival rates (see Figure 9). The arrival rates of the drugs (automatically dispensed, shelf and narcotic) and the patients (POE, script, refill) were set up in the model having an inter-arrival time modeled using an exponential distribution. During pharmacy business hours, patients enter the model at an arrival rate of one patient every 1.34 minutes. They are further assigned an Attribute of "Patient Type," randomly, based on the historical percentages of patients served by the pharmacy. 86 percent of the patients served at the Travis AFB main pharmacy are POE patients while 16 percent are new scripts.

The patients/orders then go to a possible eight Receiving Windows where receiving technicians process the order. The eight Receiving Windows also function as dispensing windows and a patient must wait to be called to the window if there is an order being dispensed (Figure 11).

The Balboa pharmacy differs from the other pharmacies in that every patient is in-processed into the Q-flow program to track the type of patient and how many scripts per patient will be processed. The biggest problem with this process is that annual patient data shows that it has added to the total patient processing time. After the registration process, the order flows by entity type up to a pharmacy technician fill station to process the order. There are two fill stations with two order filling technicians. The filled order

will then flow to the pharmacist station where two pharmacists verify them for correctness. The pharmacists then pass the filled order to one eight dispensing windows where a technician dispenses the medication to the patient.

## **2. Simulation Resources**

The simulation utilized three types of resources: receiving/dispensing windows, stations, and personnel. All resources were utilized according to a schedule based on the pharmacy's hours of operation. The pharmacy is staffed with 18 personnel, each of whom is responsible for more than one process. Also present in the Balboa pharmacy are eight windows that may be used to receive new scripts or dispense filled prescriptions. There is a stocker set that stock all medications in the inventory; however, the set is manned with six pharmacy supply technicians that do not actually handle patient orders.

## **3. Simulation Processes**

The simulation consists of five Processes. First, patients "Pull a Ticket" upon entering the pharmacy system. This process required no resources that impact the pharmacy operations and was a Triangular distribution process time of  $TRIA(1, 1.5, 2)$  minutes, as observed by the researchers. The second Process, "Registration" requires one technician and one window, and used a Triangular distribution of  $TRIA(4.5, 5, 5.5)$  minutes that was explained by the deputy pharmacy commander. All prescriptions then proceed to the pharmacy "Fill Station" Process that required one pharmacy technician and one "Fill Station". They used a Triangular distribution of  $TRIA(.75, 1, 1.25)$  minutes as observed by the authors and the pharmacy's historical data. Next, scripts are reviewed for accuracy by a pharmacist at the "Pharm Station" with a Triangular distribution of  $TRIA(1, 1.25, 1.52)$  minutes. Finally the "Dispensing Window" dispensed the filled prescription to the patient with a Triangular distribution process time of  $TRIA(.5, .75, 1)$  minutes.

#### **4. Opportunities for Improvement**

The issues for discussion were the variation of two types of patients serviced and the number of personnel utilized to operate the facility just as it was the Travis Main pharmacy. There were two types of patients: POE and script. The refill patients were being outsourced to CMOP at a servicing cost of \$2.85 per script plus the cost of the medication. Thus variation was thus reduced in the pharmacy process, but it came at a cost to the hospital. If the average monthly refill load of 50,000 is considered with a processing fee of \$2.85 and medication cost of \$5.00, the cost to the hospital per month would be over \$712,000. The cost would fluctuate for the actual medication average cost.

The second issue was the long processing time of the scripts. The Balboa hospital employs in excess of 24 personnel in its outpatient pharmacy. There are six pharmacy technicians doubling as supply technicians, 12 pharmacy technicians working the receiving/dispensing window and fill stations, and six pharmacists working two pharmacist stations. As in the case with Travis Main there is a significant amount of labor to handle the same functions.

In Scenario 1a seen in Table 26, the authors modeled the current pharmacy configuration with 12 technicians, eight receiving/dispensing windows, two fill stations and two pharmacist stations manned by six pharmacists. The average patient processing time for that scenario was 29 minutes. The scenario was run again increasing the amount of fill stations to three and then to four stations in Scenario 1b and 1c, while keeping the levels of other resources the same. The best scenario attained was operations with three fill stations getting a patient processing time of just under 27 minutes.

In the second scenario also seen in Table 26, the authors increased the amount of pharmacist workstations (windows) to explore further reductions in patient processing time. A mix of fill stations and pharmacist workstations were varied from two to four for each type of station in Scenarios 1a-4b. The optimal setup of fill stations and pharmacist stations was four stations each; however there is a minimal time difference between four of each and three of each. The increase of four each stations account for more personnel

serviced and would have to be weighed by the Balboa pharmacy for its potential value. The increase in stations yielded a total average patient processing time of 6 minutes. However, this process did not account for any possible reductions in personnel.

If the pharmacy would consider reducing personnel at the main pharmacy and the initial command driving goal of a patient processing time of 20 minutes is taken in to consideration, then personnel reductions could be made and the pharmacy would still maintain a patient processing time of less than 20 minutes. Under Scenarios 5-8, as seen in Table 26, the pharmacy could reduce the technician staff by four personnel to a total of eight and still retain an overall patient processing time of 17 minutes. However, this personnel reduction can only achieve these wait times if the increase to the number of stations is also implemented.

Table 26. Balboa Process Analyzer Results

NAME	CONTROLS			RESPONSES					
	FILL STATION	PHARM REC TECH	PHARM WINDOW	POE OUT	SCRIPT OUT	POE TIME	SCRIPT TIME	TECH UTIL	PHARM UTIL
Scenario 1a	2	12	2	294.1	49	11.555	11.518	0.156	0.059
Scenario 1b	3	12	2	307.1	51.7	11.674	11.646	0.163	0.062
Scenario 1c	4	12	2	288.3	52.3	11.482	11.545	0.155	0.059
Scenario 2a	2	12	3	293.2	44.1	11.491	11.484	0.153	0.059
Scenario 3a	3	12	3	295.3	43.3	6.35	6.33	0.65	0.34
Scenario 4a	4	12	4	282.2	46.3	6.137	6.139	6.52	0.347
Scenario 4b	3	12	4	284.1	47.1	6.25	6.24	0.65	0.34
Scenario 5	4	11	4	294.1	49	6.2	6.18	0.71	0.34
Scenario 6	4	10	4	307.1	51.7	6.56	6.56	0.78	0.35
Scenario 7	4	9	4	293.4	54.7	7.9	7.85	0.87	0.35
Scenario 8	4	8	4	293.2	44.1	17.68	17.75	0.97	0.34

## E. CONCLUSIONS AND RECOMMENDATIONS

The Balboa hospital pharmacy was designed to service POE patients and new script patients while refill patients utilize the CMOP program. The separation of refill was initially in response to decrease patient processing time and mitigate the traffic

congestion around the hospital. However, what was not done was an analysis of the personnel required to perform a pharmacy mission that was significantly reduced due to the outsourcing of the refill operations to the Veterans' Administration.

The Balboa pharmacy was also modeled in an attempt to determine if patient processing time and personnel could be reduced without sacrificing patient processing time or the amount of patients serviced on a daily basis. In the first scenario Balboa should increase their resource capacity at the fill stations to four in total and increase their pharmacist stations to operate four as well. This increase in station resources and decrease in personnel will decrease the total patient processing time from more than 20 minutes down to 17 minutes.

If the pharmacy chose to consider a reduction in personnel the patient processing time could be balanced against a cost savings in personnel costs. A reduction of four pharmacy technicians with utilization of four fill stations and four pharmacist stations would yield a total patient processing time of 17 minutes. The reduction in personnel would yield a total cost savings of \$155,000 annually. Workstation increases would come at the cost of four additional computer terminals and would be a minimal, one-time cost facilitating a decrease in processing time and the personnel cost savings. It is the recommendation of the authors that Balboa operate with eight technicians, four fill stations, and four pharmacist stations (although this could also be three fill stations and three pharmacist stations with nearly the same benefits), and any variation in patient arrivals could be handled by the supply pharmacy technicians who are licensed to perform that function when needed.

The biggest issue that arose during the study was the appearance of a large staff that only service two types of patients: POE and script. This appearance seemed excessive since the pharmacy has been operating with more personnel than it operated with prior to the use of CMOP for refill patients. Based on the simulation analysis, the authors recommend a reduction in personnel by four contractor technicians and the institution of four fill stations and four pharmacist stations to yield a total processing time of 17 minutes and a annual personnel cost saving of more than \$155,000.

THIS PAGE INTENTIONALLY LEFT BLANK

## **VIII. CONCLUSIONS AND RECOMMENDATIONS FOR FURTHER STUDY**

### **A. SUMMARY**

The escalating costs of healthcare are a fact of life for the U.S. The total cost of the military also continues to rise with the biggest percentage of this growth coming from its healthcare system. The military must internally attempt to lower costs before the consequences of inaction are amplified, through Congressional oversight. The Congress has already added to the military's overall healthcare costs with the TRICARE for Life program and extended Reservist eligibility for TRICARE. The CBO has forecasted growth of three percent, and a subsequent deficit to the system estimated at a cost of approximately \$38.4 billion (CBO Paper, 2006).

One possible tool to assist in lowering some of the overall healthcare costs is the implementation of Lean Six Sigma methodologies within all pharmacies in our Medical Treatment Facilities. This implementation would yield quantifiable benefits in efficiency, manpower, and pharmaceutical cost savings. Since 2001 pharmacies have seen significant increases in customers and subsequently costs. Congress has mandated using civilian business organizations as benchmarks to improve efficiency in the hopes of saving money within the military.

This MBA project represents the use of LSS methodology to analyze operations at the Defense Language Institute medical clinic pharmacy (small facility), the Travis Air Force Base Hospital (medium facility) and the Balboa Naval Medical Center (large facility).

### **B. CONCLUSIONS**

1. DLI was modeled to determine the possibility of reducing patient processing time by adding pharmacy receiving and or dispensing windows. Adding an additional window in dispensing or receiving had no effect on patient processing time.



However, when the model was adjusted to accommodate call a head orders for refill scripts, there was a reduction in processing time of 5 minutes. The new call a head process alleviates the bottleneck at the Receiving Window to provide a less variable flow of patients into the pharmacy.

2. The two pharmacies studied at Travis AFB were the main hospital pharmacy and the Base Exchange annex pharmacy. Both were modeled to reduce patient processing time and possibly save money in manpower.

a. Enforcing the practice of only POE patients at the main pharmacy would yield a reduced processing time of a little over 10 minutes compared to the current average of 20 minutes.

b. Our modeling simulation also yielded valuable information on personnel. The model showed the ability of the main pharmacy to reduce personnel from 24 to 14 without any increase in patient processing time. This reduction in personnel would yield a monetary benefit of \$304,537 annually.

3. Inventory management was also a concern of the authors. The pharmacy receives over \$100,000 a month in pharmaceutical returns for expired medications. This is a significant amount of money when reimbursement is just a fraction of the original cost of the medication. This highlights that medications are simply shelved without regard to shelf life of the drug or an effort to rotate stock.

4. There was a considerable issue with patient processing time at the Travis AFB Base Exchange annex pharmacy. The average total processing time was in excess of 45 minutes due a bottleneck at one computer terminal for the input of new patient scripts and there were only six personnel working in the pharmacy. Our model showed a significant reduction in processing time for the patients with an increase of two personnel and an increase in one computer terminal for input of new patient scripts. The resulting processing time for patients fell to 7 minutes.

5. The Balboa pharmacy is the only facility that does not service refill prescriptions. The facility utilizes CMOP to process all refill at a service cost of \$2.85 per prescription in addition to the cost of the medication. This is a significant amount

when it is considered that CMOP handles over 50,000 refills a month. The big issue here was that there was not a manpower study preformed post-institution of the CMOP program. The facility retained all personnel employed prior to the implementation of the CMOP program.

6. Our model of the Balboa pharmacy also yielded information pertaining to personnel manning and processing time. A reduction in four personnel would have no affect on patient processing time and yield a monetary benefit of \$155,000 annually. We also found that the institution of four fill stations and four pharmacist stations would yield a total processing time of just 17 minutes.

### **C. RECOMMENDATIONS**

There were a number of recommendations reached by the authors for each of the three medical treatment facilities studied as well as some considerations for military pharmacies as a whole. Each pharmacy was discussed at length above in their respective chapter. Below are some joint issues that could possibly be explored.

1. What remained a constant with all the facilities visited was a lack of pharmaceutical inventory management. The primary ordering mechanism for each of the facilities was DMLSS. DMLSS orders from the regional pharmaceutical prime vendor by prime vendor number and a standard unit of issue that will always arrive in the biggest unit of issue, i.e., one case of something. Often, the need for a particular item is much less than the biggest unit of issue. DMLSS as a stand-alone unit does not have the capability to manage inventory down to the smallest unit of issue, i.e., one bottle of aspirin or an each. This lack of capability highlights the need for better automation to perform true inventory management in DoD pharmacies as a whole. Since Lean doctrine has pushed for the elimination of warehouses and there is a contractual requirement for next-day deliveries from the prime vendor it is much more difficult to order what is needed for day-to-day use. Thus all of the facilities are maintaining stocks that far exceed their need between shipments from their prime vendor. Travis and Balboa are making an effort to keep on-hand stocks to a minimum, using hand-held scanners for

daily inventories and manual stock records to track order history by line item. However both were falling short of being able to truly maintain a good inventory management of all their lines of stock. Travis operated two separate stock areas in the same area to provide pharmaceuticals to the main pharmacy operation and the refill annex facility. A stock consolidation study of just one hundred of their line items showed a potential monthly cost savings of almost \$95,000 and an annual saving of more than \$1.1 million. The stock consolidation should be further analyzed at an operation like Balboa that operates not only the main medical center pharmacy, but also 11 other outlying clinics.

2. The biggest obstacle in retaining process improvements in the military is the constant turnover of the military due to reassignment. One way to ensure change is maintained for the long-term is to develop a document in the form of a standard operations procedure manual or SOP. The SOP would then be maintained, updated and considered to be a living document. Every hospital requires that each employee attend annual training during his or her birth month. Pharmacy SOP training should be incorporated into that training as well as requiring the training for all new personnel. The institutionalization of the pharmacy's procedures will help cement them for the long-term.

3. Almost every military organization is the tendency for building a bureaucracy or empire around one's command structure. To combat this tendency in future leaders and ensure continued personnel savings, the manpower section of the hospital should also routinely perform a job position audit of all the positions within each pharmacy. This process would cement the proposed/new manning configurations of each facility and officially document what personnel requirements are required to operate each facility.

4. Since the turnover of military essentially cycles at a rate of every three years, the key to long-term entrenchment or continuity is through the civilian workers of each pharmacy. Every employee must read, know and understand the entire SOP to ensure the best implementation of the key processes. Training in the facilities should be ongoing as well and standard procedures should be the central component of that training.

5. The efforts toward continuous improvement should be stressed throughout each pharmacy to include employee buy-in. Efforts like those implemented at the Travis Main Pharmacy exemplify continuous improvements and employee involvement. Tracking patient processing times for every patient processed and publishing the results to the actual patients is an excellent way to track total processing times and demonstrating to the public the pharmacy's concern with keeping the patients' main issue, processing times, to a minimum.

6. The Travis Main Pharmacy also incorporates an excellent personnel rotation process throughout the day. Every hour all personnel rotate from one station to another to prevent work monotony and ensure all personnel are trained on all process throughout the operation. This rotation keeps every employee engaged in all facets of the operation and thoroughly trains all new personnel as well. Similar efforts should be push at all pharmacies.

7. At the core of the organizational culture are its reward structure and organizational norms. Initially, we consider the reward structure as purely the proverbial "pat on the back" however closely related to this we must understand that a reward is any favorable outcome from the actions of its employees. Though, easily stated and understood organizations that receive additional personnel and funding after proving unable or unwilling to improve may have a vested in failing. This paradigm, if left unchecked by an organizations leadership can make its way to the lowest levels of a command creating a vicious cycle. Simply communicating clear goals, as Travis has done, publishing the expectations for success and consequences for failure significant will go a long way toward maintaining successful changes in the processes, however the leader must remain consistent in their requirements. Only through consistency can this and the previous recommendations push an organization to continuous improvement.

#### **D. SUGGESTIONS FOR FURTHER STUDY**

The scope of this study was somewhat limited in comparison to the subject matter. However, a number of areas addressed during our research warrant further study.

1. The Department of Defense as well as civilian and government organizations has been moving toward increasingly automated ways of doing business. The use of DMLSS seems to be a step in the right direction; however this system falls short in the area of inventory management. MTF Pharmacies in general have no standard means of tracking historical data; in order more accurately forecast usage and spending. In addition, each of the three pharmacies visited by the researchers utilizes different dispensing procedures, software and/or equipment. Though there is much to be said for the difference in the size or service of each, there was little commonality between their procedures.

2. In addition, there is an opportunity for load-leveling across facilities, or potential inventory pooling in order to eliminate waste, in the way of pharmaceutical returns, as well as decreasing the risk of stock-outs of necessary medication. The authors contend that the potential for a common, inter-operable pharmacy system should be studied in order to measure any added benefits to such a system. Much like the potential benefits of Department of Defense and commercial uses of “Total Asset Visibility” (TAV) there may similar opportunities for cost savings within pharmacy operations as well as the added benefits of standard procedures across the DoD.

3. Though it is a test program, Balboa’s use of mail delivery of pharmaceuticals appears to contribute significantly not only to greater convenience to the customer but also cost savings. While similar programs exist elsewhere, none seem to be as progressive or as successful. One possible reason for this is the manner in which funding, for pharmacies and medical treatment facilities, is allocated. Pharmacy staffs may fear losing customers to these services for fear of losing the funding (and personnel) associated with greater pharmacy usage. There may be considerable benefits to measuring and analyzing Balboa’s perceived successes in cost savings, and enforcing home delivery programs in relation to Department of Defense pharmacies, as a whole.

4. Manpower issues also deserve closer examination, as different pharmacies and hospitals seem to have different compositions of employees on their respective staffs. As previously mentioned, it was noted by the researchers that some pharmacies carry a larger composition of contracted employees than General Scale (GS) employees, at a

significantly higher cost. In addition, the GS employees carry still higher costs to these facilities than their active duty counterparts do. This study demonstrated significant cost savings and faster service by changing staffing levels. These same recommendations may be applied to countless other facilities, realizing similar savings, on a much larger scale. In addition, by simply changing the composition of employees, but not the number of personnel or their respective expertise (i.e., more Active Duty and GS personnel and fewer contractors) huge cost saving may be seen for DoD facilities.

THIS PAGE INTENTIONALLY LEFT BLANK

## LIST OF REFERENCES

- Blanche, William. Head of Pharmacy Operations for Health Affairs. Office of the Assistant Secretary of Defense (Health Affairs) TRICARE Management Activity.
- Caldwell, Chip. (2006, October). Lean-Six Sigma tools for rapid cycle cost education. *Healthcare Financial Management*, 60(10), 96-8. Retrieved April 22, 2008, from ABI/INFORM Global database. (Document ID: 1148087061).
- Caldwell, Chip; Brexler, Jim; and Tom Gillem. (2005). Engaging Physicians In Lean Six Sigma. *Quality Progress*, 38(11), 42-46. Retrieved April 22, 2008, from ABI/INFORM Global database. (Document ID: 924626551).
- CBO Cost Estimate/H.R. 5122 Conference (2006, October). Cost Estimate of John Warner National Defense Authorization Act for FY 2007. Retrieved April 22, 2008, from <http://www.cbo.gov/ftpdocs/76xx/doc7668/hr5122pgo.pdf>
- CBO Cost Estimate (2008, January). H.R. 4986 National Defense Authorization Act for FY 2008. Retrieved April 22, 2008, from <http://www.cbo.gov/ftpdocs/89xx/doc8950/hr4986.pdf>
- CBO Paper (2006, October). Long-Term Implications of Current Defense Plans: Summary Update for FY 2007. Retrieved April 22, 2008, from <http://www.cbo.gov/ftpdocs/76xx/doc7671/10-18-LongTermDefense.pdf>
- CBO Paper (2007, December). Long-Term Implications of Current Defense Plans: Summary Update for FY 2008. Retrieved April 22, 2008, from <http://www.cbo.gov/ftpdocs/76xx/doc7671/10-18-LongTermDefense.pdf>
- Coon, Scott D., (2006). The MHS Pharmacy Benefit: Efficacy of Civilian Cost Saving Strategies. *MBA Thesis (Naval Postgraduate School)*.
- Cox ER, Henderson RR. (2002). *Prescription use behavior among Medicare beneficiaries with capped prescription benefits*. *J Manage Care Pharm*. 8(5): 360-64. Retrieved April 22, 2008 from <http://www.amcp.org/>.
- Edlin, Mari (2007, December). Mail-order pharmacy steps up patient services. *Managed Healthcare Executive*, 17(12), 26-28. Retrieved April 20, 2008, from ABI/INFORM Global database. (Document ID: 1405172911).
- Esimai, Grace (2005). Lean Six Sigma Reduces Medication Errors. *Quality Progress*, 38(4), 51-57. Retrieved April 20, 2008, from ABI/INFORM Global database. (Document ID: 825035511).
- Fairbanks, Catherine B (2007). Using Six Sigma and Lean Methodologies to Improve OR Throughput. *AORN Journal*. 86(1), 73-82.



- Frederick, Jim (2007, June). House extends pharmacy choice in TRICARE military spending bill. *Drug Store News*, 29(8), 57,66. Retrieved April 20, 2008, from Research Library database. (Document ID: 1304369191).
- George, Michael L., (2002). *Lean Six Sigma: Combining Six Sigma Quality with Lean Speed*. New York; London: McGraw-Hill.
- George, Michael L., (2005). *Lean Six Sigma Pocket Toolbook*. New York; London : McGraw-Hill.
- Gibson, David R., (2007, July). Applying Lean Principles to Design Effective Supply Chains. *Army Logistician*, 39(4), 44-48. Retrieved April 20, 2008, from Military Module database. (Document ID: 1303448461).
- Gibson, David R., (2005, September). An Eight-Step Process for Improving Logistics Activities. *Army Logistician*, 37(5), 30-35. Retrieved April 20, 2008, from Military Module database. (Document ID: 974632941).
- Gibson, David R., (2003). Improving Capital Investment Strategy. *Army Medical Department Journal*, Apr/Jun; pg. 21.
- Henning, Timothy D., (2008). Pharmaceutical Cost Containment through DoD's Pharmaceutical Dispensing System Management. *MBA Professional Report (Naval Postgraduate School)*.
- Jenkins, Thomas. COR for Express Scripts Contract. TRICARE Mail Order and Retail Pharmacy Contracts TRICARE Management Activity Operations Directorate.
- Johnson, P. Fraser. (2006). Supply's Growing Status and Influence: A Sixteen-Year Perspective. *The Journal of Supply Chain Management*, 33-43.
- Kang K, Doerr K, Apte U, Boudreau M. (2005). A Decision Support Model for Valuing Proposed Improvements in Component Reliability. 2<sup>nd</sup> Annual Acquisition Research Symposium. Naval Postgraduate School.
- Kelly, Brett. Tricare Mail Order Pharmacy Contract Officer. Pharmacoeconomic Center (PEC) in San Antonio. Telephone Interview. 12 August 2008.
- Koning, Henk de, John P.S. Verver, Jaap van den, Soren Bisgaard, and Ronald J.M.M Does. (2006). Lean Six Sigma in Healthcare. *Journal for Healthcare Quality*. 28(2), 4-11.
- Linton A, Gerber M, Fagan NK, Peterson MR. Examination of multiple medication use among TRICARE beneficiaries aged 65 years and older. *Journal of Managed Care Pharmacies*. 2007;13(2):155-62. Retrieved April 22, 2008 from <http://www.amcp.org/data/jmcp/p155-62.pdf>.

- Linton A, Gerber M, Fagan N. K., & Peterson M. (2007). Factors Associated With Choice of Pharmacy Setting Among DoD Health Care Beneficiaries Aged 65 Years or Older. *Journal of Managed Care Pharmacy*. 13(8), 677-686.
- Medco, CVS Win Separate Pieces Of Federal Employee Pharmacy Benefits Contract. (7 June). *FinancialWire*, 1. Retrieved April 20, 2008, from ABI/INFORM Global database. (Document ID: 1284302891).
- Miller, Julie (2007, May). Pharmacy Benefit Forecasting. *Managed Healthcare Executive*, 17(5), 25-26,28-29. Retrieved April 20, 2008, from ABI/INFORM Global database. (Document ID: 1273777821).
- Ogden, Jeffery A. (2006, October). Supply Base Reduction: An Empirical Study of Critical Success Factors. *The Journal of Supply Chain Management*, 29-39.
- Paparone, Christopher R , Dr. (2008). A Values-Based Critique of Lean and Six as a Management Ideology. *Army Logistician*. 40(1), 34-40.
- Philpott, Tom. (2007, September). Employer-Paid Tricare Plans to End. *US Military.Com*. Retrieved April 22, 2008, from <http://www.military.com/features/0,15240,150697,00.html>
- Rector TS, Finch MD, Danzon PM, Pauly MV, Manda BS. Effect of tiered prescription copayments on the use of preferred brand medications. *Med Care*. 2003;41(3):398-406.
- Rep. Bilirakis Introduces TRICARE Mail-Order Pharmacy Pilot Program Act. (2007, June 1). *US Fed News Service, Including US State News*. Retrieved April 20, 2008, from Research Library database. (Document ID: 1280420971).
- Robinson, Brian. (2008). DoD Rallies Around Lean Six Sigma. *DoD Spotlight*. (22)5, 32-36.
- Schaffer R.H. and Thomson H. A. (1992) *Successful Change Programs Begin with Results*. *Harvard Business Review*, 70(1): 81-89.
- Schommer JC, Mott DA, Hansen RA, Cline RR. (2003) Selected characteristics of senior citizens' prescription drug payment and procurement in 1998 and 2001. *J Manag Care Pharm*. 9(5):408-15. Retrieved April 22, 2008 from <http://www.amcp.org/data/jmcp/Research-408-415.pdf>.
- Scott, John. (2007). Process Optimization for Service Organizations Isn't Rocket Science. *Quality Progress*, 40(10), 72. Retrieved April 22, 2008, from ABI/INFORM Global database. (Document ID: 1379819451).

- Tricare beneficiaries are saving time and money by making the switch to mail order pharmacy. (2007, November 29). US Fed News Service, Including US State News. Retrieved April 22, 2008, from Research Library database. (Document ID: 1391031941).
- Tricare mail order pharmacy keeps beneficiaries satisfied, attracts more users. (2006, October 4). US Fed News Service, Including US State News. Retrieved April 22, 2008, from Research Library database. (Document ID: 1150718081).
- Tricare beneficiaries save with mail-order pharmacy. (2007, November 29). *US Fed News Service, Including US State News*. Retrieved April 20, 2008, from Research Library database. (Document ID: 1390773141).
- Thomas CP, Wallack SS, Lee S, Ritter GA. (2001). Impact of health plan design and management on retirees' prescription drug use and spending, 2001. *Health Aff.* December 4, 2002. Retrieved April 22, 2008 from <http://content.healthaffairs.org/cgi/reprint/hlthaff.w2.408v1>.
- Thompson, Jody; Miller, Tom; Krantz, Amy; and Tom Thomas. (2008, March). Six Sigma Engages Physicians in Achieving Strategic Performance Improvement at OSF Saint Francis Medical Center. *Global Business and Organizational Excellence*, 27(3), 6. Retrieved April 22, 2008, from ABI/INFORM Global database. (Document ID: 1428899581).
- Valluri, S, Enrique Seoane-Vasquez, Rosa Rodriguez-Monguio and Sheryl L. Szeinbach. (2007). Drug Utilization and cost in a Medical population: A simulation study of community vs. mail order pharmacy. *BMC Health Services Research*. 7(122).
- Weickum, Ricke. Department Head of Pharmacy at Madigan Army Medical Center. Pharmacy Consultant, U.S. Army Western Regional Medical Command. Chief, Department of Pharmacy at Madigan Army Medical Center. [ricke.weickum@us.army.mil](mailto:ricke.weickum@us.army.mil).

## APPENDIX A

### Project Charter – LSS in Pharmacy Operations

---

**Date:** 21 July 2008      **Project No. & Name:** LSS in Pharmacy Operations

**Project Team Leader:** Tom Sikora, Andy Nuce, and Lydia Robinson

**Project Sponsor:** N1      **Project Champion:** Dr. Kang, Apte, and Heath

---

**Problem/Opportunity Statement:**

An increase in beneficiaries is a result of 9/11 with the War on Terror and implementation of Tricare for Life. Costs are significantly increasing in all areas of healthcare in and out of the military. Post Iraq and with the possibility of a change in party in the office of the president there will be a reduction in funding to the military and subsequently the Medical Departments.

---

**Business Impact:**

There are possible monetary benefits from analysis of pharmaceutical operations in terms of pharmaceutical acquisition, work processes, and expansion of personnel and facilities. Improved customer service in terms of Customer Wait Time and reduction in costs in terms of product, facilities and manpower (services provided).

---

**Goal Statement:**

Reduction in overall costs in Pharmacy operations either in manpower, facilities and drug costs by \$50,000; and an improvement in customer satisfaction through reduced wait time by 30 percent and analysis of the voice of the customer. Identify target wait times for customers and seek to reduce it through analysis of process times and activities. Individual costs to pharmacies must be identified and then mapped to the value stream for the customer for possible reductions in costs. Manpower, facility and product costs are all significant.

---

**Project Scope:**

Scope will encompass acquisition of product, how it arrives, how it is paid for, how it enters into the customer value stream and how the customer exits the process with the product. There is no limit to the scope from acquisition to customer exit from the process flow. 2 of 3 facilities has approved the project and our customer survey has been approved by NPS.

---

**Project Plan/Timetable:**

Define: Ongoing

Measure: Ongoing

Analyze: Ongoing for DLI, Will commence after 8 Aug for Travis, TBA on 3<sup>rd</sup> facility

Improve: Will commence after 3<sup>rd</sup> visit

Control: Will commence after 3<sup>rd</sup> visit

THIS PAGE IS INTENTIONALLY LEFT BLANK

## APPENDIX B

### Medical Treatment Facility Pharmacy Customer Service Survey

The following is an informal survey to be used by students' of the Naval Post-graduate School in Monterey, CA who are in no way affiliated with this Medical Treatment Facility or Pharmacy staff. The results of the survey will be used for academic purposes only and will remain anonymous.

**What is your service component?**

(Army    Navy    Air Force    Marine    Coast Guard    Other)

**What is your status?**

(Reserve    Active Duty    Retired    Dependent    Gov. Employee)

**How often must you normally visit the pharmacy to refill your prescription(s)?**

Less than once    Greater than once    Once  
per month    per month    each month

**How do you travel when you refill your prescription(s)?**

(self-transport    public transportation    other\_\_\_\_\_)

**How far must you travel to refill your prescription(s)?**

Less than 20 miles    Between 20 and 50 miles    Greater than 50 miles

**What is your average wait time when filling your prescriptions?**

less than 30    between 30 minutes    greater than 1  
minutes    and 1 hour    hour

**How satisfied are you with the pharmacy services and overall experience?**

(Very Satisfied    Moderately Satisfied    No Opinion    Unsatisfied)

**How would you view delivery of refill prescriptions to your home?**

Favorably    Unfavorably    No opinion

**Comments/Suggestions to improve pharmacy services:**

---

---

---

---

---

THIS PAGE INTENTIONALLY LEFT BLANK

## **INITIAL DISTRIBUTION LIST**

1. Defense Technical Information Center  
Ft. Belvoir, Virginia
2. Dudley Knox Library  
Naval Postgraduate School