



Calhoun: The NPS Institutional Archive
DSpace Repository

Theses and Dissertations

1. Thesis and Dissertation Collection, all items

1951

Applications and uses of transistors.

Calbrese, Joseph Frank

Monterey, California : Naval Postgraduate School ;

<https://hdl.handle.net/10945/13948>

Downloaded from NPS Archive: Calhoun



Calhoun is the Naval Postgraduate School's public access digital repository for research materials and institutional publications created by the NPS community. Calhoun is named for Professor of Mathematics Guy K. Calhoun, NPS's first appointed -- and published -- scholarly author.

Dudley Knox Library / Naval Postgraduate School
411 Dyer Road / 1 University Circle
Monterey, California USA 93943

<http://www.nps.edu/library>

APPLICATIONS AND USES
OF TRANSISTORS

BY
J. F. CALABRESE

THESIS
C186

Library
U. S. Naval Postgraduate School
Annapolis, Md.

APPLICATIONS AND USES OF TRANSISTORS

-

J. F. Calabrese

APPLICATIONS AND USES OF TRANSISTORS

by

Joseph Frank Calabrese
Lieutenant, United States Navy

Submitted in partial fulfillment
of the requirements
for the degree of
MASTER OF SCIENCE
in
ENGINEERING ELECTRONICS

United States Naval Postgraduate School
Annapolis, Maryland
1951

This work is accepted as fulfilling
the thesis requirements for the degree of

MASTER OF SCIENCE

in

ENGINEERING ELECTRONICS

from the

United States Naval Postgraduate School

PREFACE

The object of this paper is to show some of the uses and applications of transistors at the present time. The laboratory work and a great part of the research to writing this thesis was done at the Federal Telecommunications Laboratory at Nutley, New Jersey. The writer wishes to express his thanks to those officials of FTL and more particularly to Mr. Don D. Greig, Mr. Arnold Levine and Mr. Sidney Moskowitz who made it possible for him to work with this group. He desires to express his sincere appreciation to Mr. Moskowitz for his kind assistance and technical advice.

TABLE OF CONTENTS

	Page
Certificate of Approval	1
Preface	ii
Table of Contents	iii
List of Illustrations	iv
Chapter I. Introduction	1
1. Summary	1
2. General discussion and theory of transistors	1
Chapter II. Applications	7
1. Blocking Oscillator	7
2. Oscillators	19
3. High frequency amplifier	28
Chapter III. Conclusion	38
Bibliography	40

LIST OF ILLUSTRATIONS

Figure	Page
1. Basic Circuit of Transistor Amplifier	3
2. Equivalent T network for describing transistor small signal performance. Voltage version.	4
3. Current version of equivalent T network.	4
4. PRC-13 Modulator.	8
5. Graph of Collector Current vs Collector Voltage. Emitter Voltage Constant.	10
6. Circuit Diagram of Transistor Blocking Oscillator.	11
7. Alternate Circuit of Transistor Blocking Oscillator.	11
8. Waveforms of Self-Driven Blocking Oscillator.	13
9. Effect of Varying C on Frequency and D.C. Emitter Voltage.	14
10. Photographs of Transistor Blocking Oscillator Waveforms.	16 - 17
11. Waveforms of Driven Blocking Oscillator.	18
12. Circuit Diagram of Sawtooth Driving Transistor Blocking Oscillator	20
13. Waveforms Obtained with Sawtooth Input to Transistor Blocking Oscillator.	21
14. Experimental Characteristic Curves of Transistor. The desired operating region is shaded.	22
15. Basic Oscillator Circuit.	24
16. Circuit Diagram of Transistor Oscillator (Audio)	26
17. Frequency and Audio Output Curves for Transistor Oscillator.	27
18. Five Megacycle Transistor Oscillator.	26
19. Current gain versus frequency plot for Type-A transistor.	29

LIST OF ILLUSTRATIONS
(Continued)

- | | | |
|-----|---|----|
| 20. | Three terminal representation of transistor at high frequencies. | 33 |
| 21. | Circuit of 23-mc amplifier used for testing high-frequency response of transistors. | 35 |
| 22. | Frequency Response of 23-mc Amplifier | 36 |

CHAPTER I

1. Summary.

This paper will first present a general discussion on transistors dealing briefly with the physical and electrical properties. The equivalent circuits of a transistor will be shown and an analogy drawn with vacuum tube triode amplifiers. The circuit and data of a blocking oscillator using a transistor, will be discussed and waveforms shown. This circuit can possibly be used in a modulator for portable equipment as soon as quality control of transistor manufacture is attained. Next oscillators will be discussed, to be followed by high frequency operation of amplifiers.

2. General discussion and theory of transistors.

The transistor is a three-element electronic device which utilizes a newly-discovered principle involving a semiconductor as the basic element¹. The device consists of three electrodes placed on a block of germanium. Two, called the "emitter" and "collector" are of the point-contact, rectifier type and are placed in close proximity (approximately .001 to .002 in.) on the upper surface. The third is a large area low resistance contact on the underside of the germanium block. The germanium is prepared in the same way as that used for high back-voltage rectifiers. Each point contact, when connected separately with the base electrode, has characteristics similar to those of the high back-voltage rectifier.

When the two point contacts are placed close together on the surface and DC bias potentials are applied there is a mutual influence which causes the transistor to exhibit amplifying properties.

The action of the transistor can be explained in terms of current flow in semi-conductors.² There are two types of current flow in semi-conductors, the "N" type and the "P" type. In the "N" type the current consists of flow of electron charge; in the "P" type the current consists of flow of virtual positive charge (image of electrons).

The physics involved in the two types of conduction may be understood by considering a typical semi-conductor such as silicon. Each silicon atom has four valence electrons. Pairs of silicon atoms form bonds, each atom contributing its four valence electrons, to complete the bond. If an impurity such as phosphorous, with five valence electrons, is introduced into the silicon, the phosphorous atoms will form bonds with the silicon atoms. But the silicon-phosphorous bonds differ from the silicon-silicon bonds inasmuch as there is one excess (free) electron contributed by each bond. These free electrons contribute to current flow in much the same manner as current flow in metals. This is "N" type of conduction as defined above.

"P" type of conduction can be obtained by introducing an impurity like boron (three valence electrons per atom) into silicon. In this case the silicon and boron atoms form incomplete bonds for one electron must be added. This hole in the

bond can be filled from an electron from an adjacent silicon atom when the semi-conductor is subjected to the influence of an external magnetic field. This in turn leaves a hole and the passing of this hole is likened to the flow of positive charge.

It is found experimentally that an external field affects the flow of holes. It has also been found that by using germanium and impurities, instead of silicon as described above, and a large forward current, there is an increase in concentration of holes in the area of the point contact. These holes spread away from the point, flowing in all directions along the surface but do not penetrate into the material.

A second point (the collector) is placed into this area of interaction. See Fig. 1.

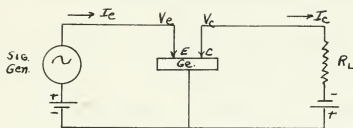

Fig. 1.

The negative bias applied to the collector causes a very small current to flow from the germanium in the absence of hole conduction produced by the emitter. When the positive bias is applied to the input, however, holes are attracted to the output point contact, which is biased negatively, and these are absorbed, thus increasing the current in the output circuit. Variations in the input current change the number of

holes released toward the collector and thus vary the output current proportionately.

If the transistor be considered as a "black box"³ with two input and two output terminals, then for small signal use (linear problems) there are two possible equivalent circuits for the transistor. One is a T of resistors, each of which is associated with one of the transistor leads, and a voltage generator whose ratio to the emitter current is also of the dimensions of a resistance, in series with the collector lead. (See Fig. 2.)

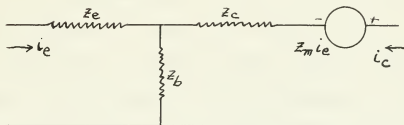

Fig. 2. Equivalent T network for describing transistor small signal performance. (Voltage version.)

The other is obtained by converting the series voltage generator to an equivalent shunt generator whose ratio to emitter current is a dimensionless constant "a". This dimensionless constant is the current amplification factor and is described by the equation

$$"a" = \left. \frac{\partial I_c}{\partial I_e} \right]_{V_c \text{ constant}}$$

The actual value of "a" depends upon the bias.

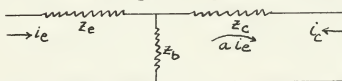

Fig. 3. Current version of equivalent T network.

Using this black box approach, the physics of the transistor may be ignored and an analogy made with the conventional triode tube. The emitter is analogous to the cathode, the base to the grid and the collector to the plate. There is one difference that may be useful. It is that one of the T resistors, in the equivalent circuit, acts as a positive feedback element depending on which of the three amplifier circuits are used.

In the circuit where the base is grounded, the behavior is similar to the grounded-grid triode since (1) there is no phase reversal between the input and output of the transistor, (2) the input impedance is low (of order of 500 ohms),⁴ while output is high (30,000 ohms).⁴ The differences are: (1) the quantity "a", the current amplification factor, which for the transistor, may be considerably greater than unity while the analogous quantity for the triode is close to unity for usual conditions, (2) the base resistance provides positive feedback hence the circuit tends toward oscillation.

If the collector is grounded, the circuit is analogous to a cathode follower and can be used as an impedance matching device for high-to-low since the input impedance is of order of 20,000 ohms and output 500 ohms. If the emitter is grounded, the circuit behavior is similar to a grounded-cathode amplifier and the stage provides a change in signal polarity in contrast to no change in polarity in the grounded base case. Also, in this circuit, the base resistance is usually negligible in contrast to the pronounced effect on reverse transmission of the

grounded base amplifier and hence the role of feedback element is taken over by the emitter resistance. The input impedance is of the order of 5,000 ohms while output impedance is 10,000 ohms.

The analogies are fairly close when "a" = 1 but as "a" becomes greater than 1 the analogy becomes less close.

In conventional vacuum tubes, the tubes are described in terms of admittance while the transistor lends itself to an impedance basis. This is so because in the case of a triode, the voltages on the grid and plate are usually taken as independent variables while the grid and plate currents are taken as functions of the voltages. It becomes natural to measure tubes with regulated power supplies having low impedance to keep the voltages constant and hence one is led to describe tubes in terms of admittance.

The trouble with this scheme for transistors is that many of them oscillate when connected to low impedances, i.e., many transistors are short-circuit unstable. To avoid this difficulty it is convenient to measure with high impedances in the leads; the analytical counterpart is to regard the currents as independent variables leading naturally to a description of the transistor in terms of impedances.

CHAPTER II

1. Transistor Blocking Oscillator.

In the PRC-13 Modulator (Marine Corps Mobile Pack Unit), a sawtooth wave whose frequency is 8Kc is modulated by a 3Kc audio wave and the resultant is applied to the grid of a 6BF7 blocking oscillator tube, Fig. 4. The 6BF7 tube is held cut off by a d. c. bias. When the modulated sawtooth reaches a certain value determined by the d. c. bias, the tube conducts and an output pulse is obtained. The position of the pulse in the time axis is determined by the modulating audio wave since it raises or lowers the sawtooth level and hence the tube respectively conducts earlier or later in time giving pulse position modulation.

The advantage of small size, ruggedness, no filament power, less heat dissipation and long life expectancy gave impetus to the investigation and development of a transistor blocking oscillator circuit.

Blocking oscillators, using conventional grounded-cathode triode vacuum tubes, are transformer coupled feedback oscillators in which plate current is permitted to flow for one-half cycle after which cutoff bias is imposed on the grid to prevent further oscillations.

In the grounded base case of transistor operation the transistor is a crystal triode, acts as follows; when the emitter or control voltage is reduced to zero or negative

PRC/13 Modulator.

6BF7 tube.

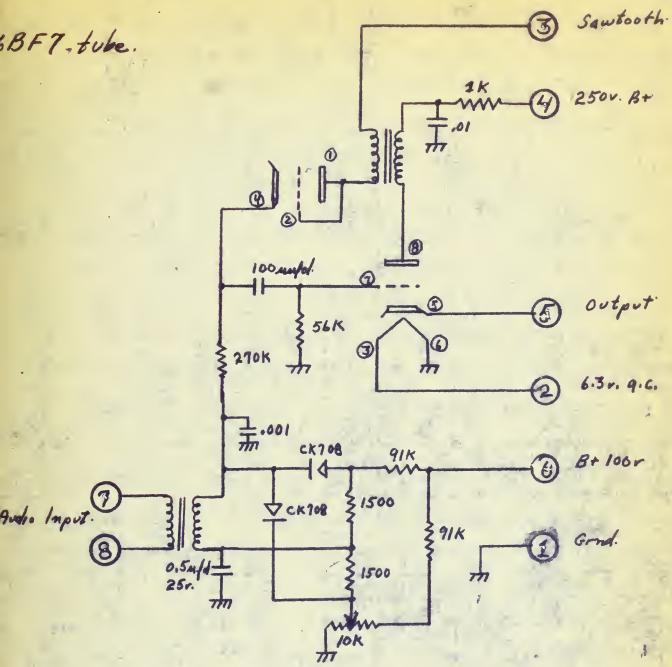

FIG. 4 - PRC MODULATOR

B.B. 2/14/51

voltages, the transistor is not cutoff but the emitter does lose control. The collector current still flows but it is no longer a function of the emitter voltage. This is shown in curves plotted for a transistor amplifier (Fig. 5).

Using the analogy previously mentioned, a grounded emitter transistor blocking oscillator is shown in Fig. 6. The input impedance of the pulse transformer is 10,000 ohms while the output impedance of the transistor is of the order of 10,000 ohms thus giving an impedance match. The polarities on the transformer are as shown since 180° phase shift is desired to compensate for the 180° phase shift occurring in the transistor so that positive feedback to the base is obtained.

After various adjustments, a pulse output (collector-to-ground) was observed on the RCA Mod. 715 Oscilloscope which has a 10 megacycle pass band. It was 3 volts peak-to-peak as measured by the calibrator on the scope and was 3 microseconds wide at the peak. The rise time was one-half microsecond and the free-running PRF was 13 Kc. However the circuit caused easy burn out of the crystal due to momentary overloads.

The circuit shown in Fig. 7 also produced an output pulse and it showed no signs of easy burn out since very low biasing voltages were used. The feedback goes to the emitter instead of the base and since the emitter is equivalent to the cathode and base to the grid, the transformer polarity is as shown. The output pulse (collector-to-ground) was 2.8 volts peak-to-peak, pulse width 8 microseconds and a PRF of 10 Kc. The rise

FIG 5

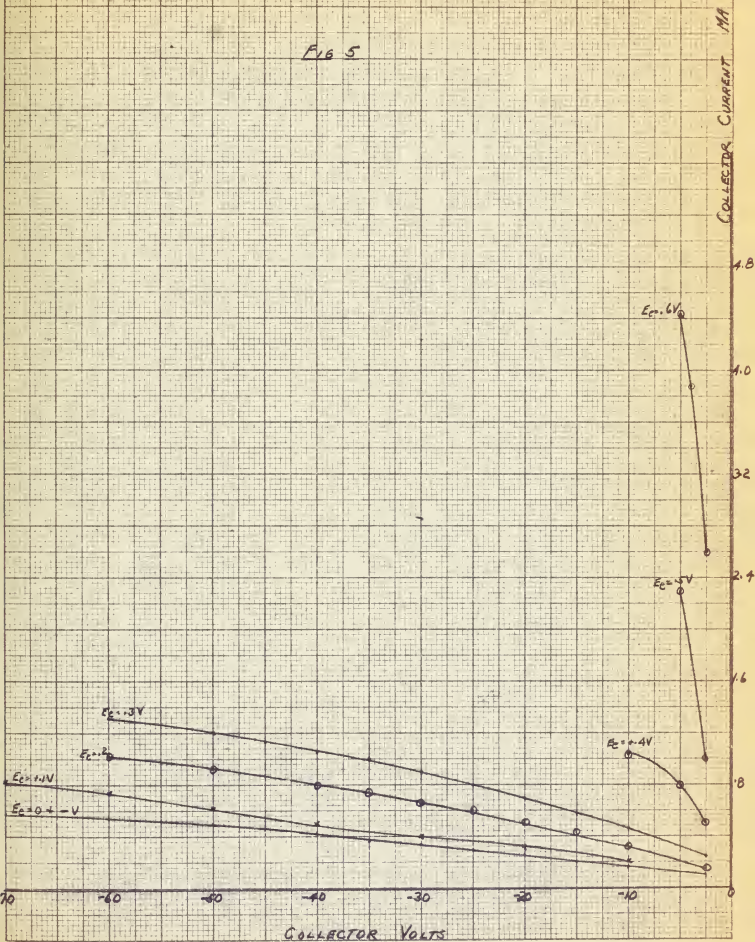

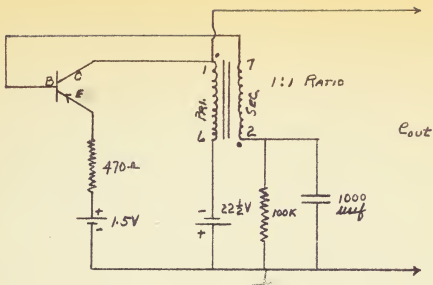

FIG. 6

CIRCUIT DIAGRAM OF TRANSISTOR BLOCKING OSCILLATOR

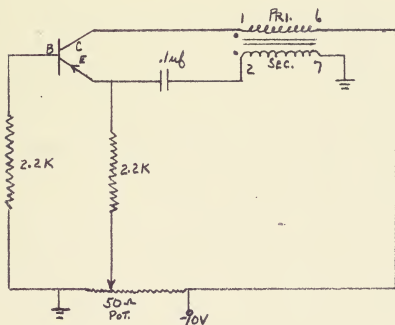

FIG. 7

ALTERNATE CIRCUIT OF TRANSISTOR BLOCKING OSCILLATOR

time was 1 microsecond; the emitter voltage was -0.9 volts d.c. and the collector voltage -5.4 volts d.c. as measured with a Simpson 260 meter. The PRF was obtained by beating the output signal with a Hewlett-Packard audio oscillator. Waveforms for the base, emitter, collector and pin 2 of the transformer are shown in Fig. 8.

The effect of varying the capacitor, C , on the PRF and the emitter voltage is shown in Fig. 9. Increasing C , increases the time constant and hence decreases the PRF. It should be noted that the emitter voltage is very critical. When $E_e = -0.3$ volts d.c. no oscillations are present and increasing E_e slightly caused oscillations to start. E_e jumped to -0.9 volts with E_c (collector voltage) remaining constant at -5.4 volts as did the base-to-ground voltage at 0.35 volts.

The explanation of the operation appears to be as follows: initially the transistor is carrying a small steady-state current. Some internal change causes the emitter to go slightly positive with respect to the base. The sudden current flow resulting in the collector circuit causes the transformer voltage to build up rapidly with positive polarity at points indicated by dots on the schematic drawing. The positive pulse in the secondary is fed back regeneratively to the emitter through the capacitor. Due to the short-circuit instability of the transistor, a new value of collector current is approached. It increases until some time, T , when because of saturation of the core, or transistor or both, the change in primary

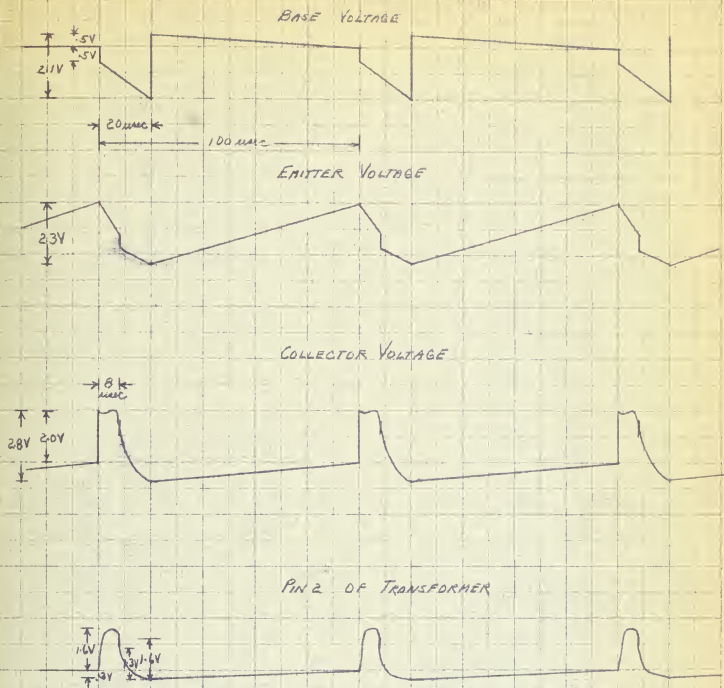
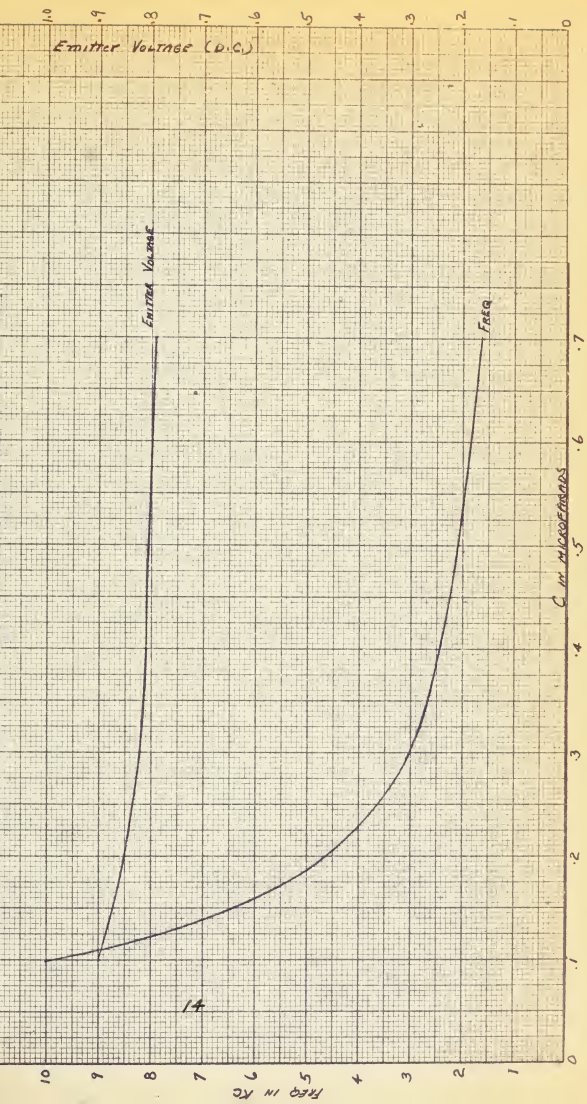

FIG. B WAVEFORMS OF SELF-DRIVEN BLOCKING OSCILLATOR

FIG. 9 EFFECT OF VARYING C ON FREQUENCY AND D.C. EMITTER VOLTAGE



current no longer produces a regenerative effect. The collapsing field generates a secondary voltage of opposite polarity which cuts off the transistor or returns it to the small steady-state current. The emitter potential then rises exponentially towards the quiescent value.

An item of interest is that although the transistor used in this circuit was observed to have characteristics to make it a poor amplifier, the circuit can be made to function because the transistor exhibits short-circuit instability for low collector voltages.

Another transistor was placed in the circuit and was made to operate. However it fired when E_e reached -1.3 volts and then jumped to -1.85 volts while E_c remained constant at -7.6 volts. The free running PRF was 11 Kc. Photographs were taken of emitter, collector, pin 2 of transformer and base voltages (Fig. 10). Two exposures on each picture are shown.

This blocking oscillator circuit can be driven by a negative input pulse to the base through a .002 micro-farads condenser up to 20 Kc. (Fig. 11). The values of the components for optimum performance were:

Emitter Resistance = 2300 ohms

C = .004 microfarads

Trigger Pulse 0.5 microseconds wide, 1 volt rms

PRF = 10 Kc.

When E_e reached -0.35 volts oscillations occurred and E_e jumped to -.85 volts with E_c remaining constant at -4.6 volts

PHOTOGRAPHS OF TRANSISTOR BLOCKLING OSCILLATOR WAVEFORMS

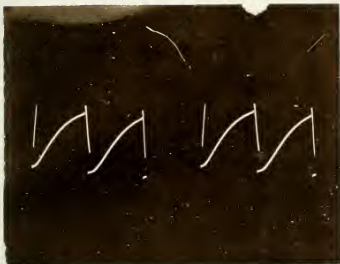

FIG. 10A
EMITTER VOLTAGE
9 VOLTS PEAK-TO-PEAK



FIG. 10B
COLLECTOR VOLTAGE
11 VOLTS PEAK-TO-PEAK

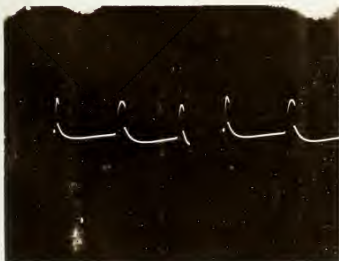

FIG. 10C
PIN 2 OF TRANSFORMER
6 VOLTS PEAK-TO-PEAK

PHOTOGRAPHS OF TRANSISTOR BLOCKING OSCILLATOR WAVEFORMS



FIG. 10D
VOLTAGE OF BASE
13.5 VOLTS PK.-TO-PK.



FIG. 10E
COLLECTOR VOLTAGE
EXPANDED VIEW
11 VOLTS PK.-TO-PK.

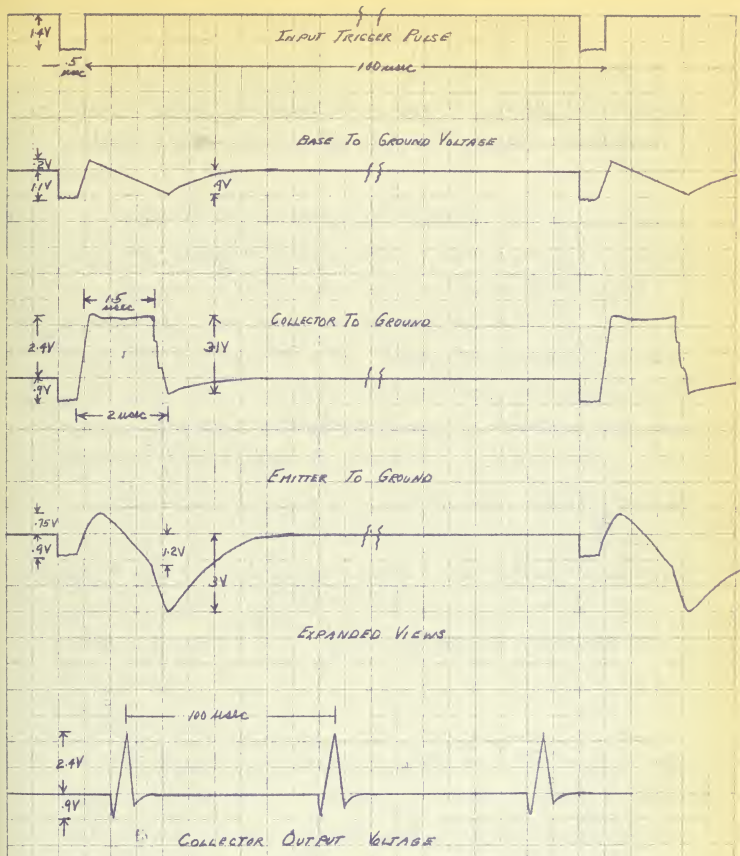

FIG 11 WAVEFORMS OF DRIVEN BLOCKING OSCILLATOR

and base voltage at .35 volts. The effect of increasing C was to increase the pulse width while decreasing the emitter resistance made the trailing edge of the output pulse less steep.

To reproduce the operating conditions of the blocking oscillator in the PRC-13 Modulator, a negative sawtooth generator was used as in Fig. 12. An input pulse of 25 microseconds with a period of 125 microseconds was used to obtain a sawtooth frequency of 8 Kc. Cathode degeneration was used in the phase inverter stage so as to obtain loss in amplitude since a low output voltage was required. Waveforms were obtained as shown in Fig. 13.

The transistor fired or pulsed when the sawtooth reached 1.2 volts. When the slope of the sawtooth was varied the position of the output pulse moved in the horizontal axis; as slope was made steeper the output pulse moved to the left. It was again noted that the bias voltage on the emitter was very critical.

2. Oscillators.

As previously mentioned, an impedance in the common lead causes positive rather than negative feedback. Thus by putting an LC circuit in the base lead, the circuit will oscillate.

The audio frequency behavior of the transistor is described by the experimentally obtained characteristic curves illustrated in Fig. 14 if its input and output voltages and currents are as shown in Fig. 1.

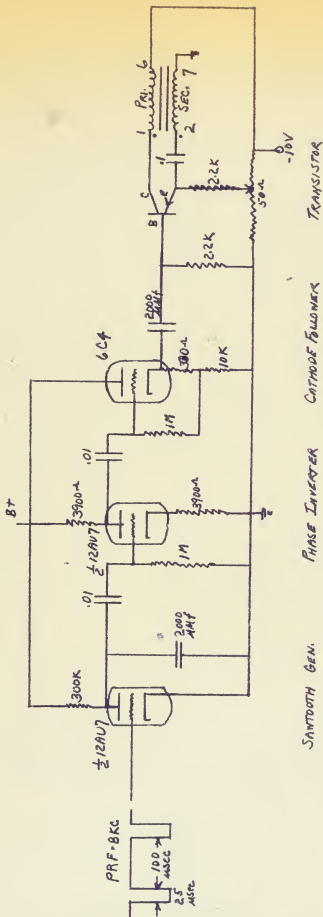
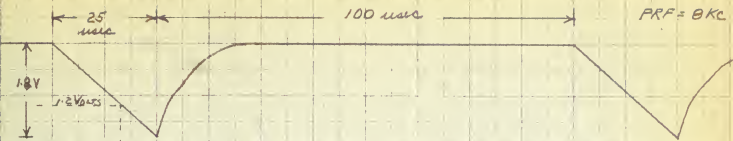

FIG. 12

TOLERANCE	MATERIAL	TITLE
UP TO 6		
ABOVE 6		
ABOVE 24		
ABOVE 24		
±.005	±.010	±.015
±.01	±.02	±.03
±.02	±.04	±.06
±.04	±.08	±.12
±.08	±.16	±.24
±.16	±.32	±.48
±.32	±.64	±.125
±.64	±.125	±.25
±.125	±.25	±.50
±.25	±.50	±.100
±.50	±.100	±.200
±.100	±.200	±.400
±.200	±.400	±.800
±.400	±.800	±.1600
±.800	±.1600	±.3200
±.1600	±.3200	±.6400
±.3200	±.6400	±.12800
±.6400	±.12800	±.25600
±.12800	±.25600	±.51200
±.25600	±.51200	±.102400
±.51200	±.102400	±.204800
±.102400	±.204800	±.409600
±.204800	±.409600	±.819200
±.409600	±.819200	±.1638400
±.819200	±.1638400	±.3276800
±.1638400	±.3276800	±.6553600
±.3276800	±.6553600	±.13107200
±.6553600	±.13107200	±.26214400
±.13107200	±.26214400	±.52428800
±.26214400	±.52428800	±.104857600
±.52428800	±.104857600	±.209715200
±.104857600	±.209715200	±.419430400
±.209715200	±.419430400	±.838860800
±.419430400	±.838860800	±.1677721600
±.838860800	±.1677721600	±.3355443200
±.1677721600	±.3355443200	±.6710886400
±.3355443200	±.6710886400	±.13421772800
±.6710886400	±.13421772800	±.26843545600
±.13421772800	±.26843545600	±.53687091200
±.26843545600	±.53687091200	±.107374182400
±.53687091200	±.107374182400	±.214748364800
±.107374182400	±.214748364800	±.429496729600
±.214748364800	±.429496729600	±.858993459200
±.429496729600	±.858993459200	±.1717986918400
±.858993459200	±.1717986918400	±.3435973836800
±.1717986918400	±.3435973836800	±.6871947673600
±.3435973836800	±.6871947673600	±.13743895347200
±.6871947673600	±.13743895347200	±.27487790694400
±.13743895347200	±.27487790694400	±.54975581388800
±.27487790694400	±.54975581388800	±.109951162777600
±.54975581388800	±.109951162777600	±.219902325555200
±.109951162777600	±.219902325555200	±.439804651110400
±.219902325555200	±.439804651110400	±.879609302220800
±.439804651110400	±.879609302220800	±.1759218604441600
±.879609302220800	±.1759218604441600	±.3518437208883200
±.1759218604441600	±.3518437208883200	±.7036874417766400
±.3518437208883200	±.7036874417766400	±.14073748835532800
±.7036874417766400	±.14073748835532800	±.28147497671065600
±.14073748835532800	±.28147497671065600	±.56294995342131200
±.28147497671065600	±.56294995342131200	±.112589990684262400
±.56294995342131200	±.112589990684262400	±.225179981368524800
±.112589990684262400	±.225179981368524800	±.450359962737049600
±.225179981368524800	±.450359962737049600	±.900719925474099200
±.450359962737049600	±.900719925474099200	±.1801439850948198400
±.900719925474099200	±.1801439850948198400	±.3602879701896396800
±.1801439850948198400	±.3602879701896396800	±.7205759403792793600
±.3602879701896396800	±.7205759403792793600	±.14411518807585587200
±.7205759403792793600	±.14411518807585587200	±.28823037615171174400
±.14411518807585587200	±.28823037615171174400	±.57646075230342348800
±.28823037615171174400	±.57646075230342348800	±.11529215046068469600
±.57646075230342348800	±.11529215046068469600	±.23058430092136939200
±.11529215046068469600	±.23058430092136939200	±.46116860184273878400
±.23058430092136939200	±.46116860184273878400	±.92233720368547756800
±.46116860184273878400	±.92233720368547756800	±.184467440737095513600
±.92233720368547756800	±.184467440737095513600	±.368934881474191027200
±.184467440737095513600	±.368934881474191027200	±.737869762948382054400
±.368934881474191027200	±.737869762948382054400	±.1475739525896764108800
±.737869762948382054400	±.1475739525896764108800	±.2951479051793528217600
±.1475739525896764108800	±.2951479051793528217600	±.5902958103587056435200
±.2951479051793528217600	±.5902958103587056435200	±.11805916207174112870400
±.5902958103587056435200	±.11805916207174112870400	±.23611832414348225740800
±.11805916207174112870400	±.23611832414348225740800	±.47223664828696451481600
±.23611832414348225740800	±.47223664828696451481600	±.94447329657392902963200
±.47223664828696451481600	±.94447329657392902963200	±.188894659314785805926400
±.94447329657392902963200	±.188894659314785805926400	±.377789318629571611852800
±.188894659314785805926400	±.377789318629571611852800	±.755578637259143223705600
±.377789318629571611852800	±.755578637259143223705600	±.1511157274518286447411200
±.755578637259143223705600	±.1511157274518286447411200	±.3022314549036572894822400
±.1511157274518286447411200	±.3022314549036572894822400	±.6044629098073145789644800
±.3022314549036572894822400	±.6044629098073145789644800	±.12089258196146291579289600
±.6044629098073145789644800	±.12089258196146291579289600	±.24178516392292583158579200
±.12089258196146291579289600	±.24178516392292583158579200	±.48357032784585166317158400
±.24178516392292583158579200	±.48357032784585166317158400	±.96714065569170332634316800
±.48357032784585166317158400	±.96714065569170332634316800	±.193428131138340665268633600
±.96714065569170332634316800	±.193428131138340665268633600	±.386856262276681330537267200
±.193428131138340665268633600	±.386856262276681330537267200	±.773712524553362661074534400
±.386856262276681330537267200	±.773712524553362661074534400	±.1547425049106725322149068800
±.773712524553362661074534400	±.1547425049106725322149068800	±.3094850098213450644298137600
±.1547425049106725322149068800	±.3094850098213450644298137600	±.6189700196426901288596275200
±.3094850098213450644298137600	±.6189700196426901288596275200	±.12379400392853802577192550400
±.6189700196426901288596275200	±.12379400392853802577192550400	±.24758800785707605154385100800
±.12379400392853802577192550400	±.24758800785707605154385100800	±.49517601571415210308770201600
±.24758800785707605154385100800	±.49517601571415210308770201600	±.99035203142830420617540403200
±.49517601571415210308770201600	±.99035203142830420617540403200	±.198070406285660841251080806400
±.99035203142830420617540403200	±.198070406285660841251080806400	±.396140812571321682502161612800
±.198070406285660841251080806400	±.396140812571321682502161612800	±.792281625142643365004323225600
±.396140812571321682502161612800	±.792281625142643365004323225600	±.158456325028528673000846451200
±.792281625142643365004323225600	±.158456325028528673000846451200	±.316912650057057346001692822400
±.158456325028528673000846451200	±.316912650057057346001692822400	±.633825300114114692003385644800
±.316912650057057346001692822400	±.633825300114114692003385644800	±.1267650600228229384006771289600
±.633825300114114692003385644800	±.1267650600228229384006771289600	±.2535301200456458768013542579200
±.1267650600228229384006771289600	±.2535301200456458768013542579200	±.5070602400912917536027085158400
±.2535301200456458768013542579200	±.5070602400912917536027085158400	±.10141204801825835072054170316800
±.5070602400912917536027085158400	±.10141204801825835072054170316800	±.20282409603651670144108340633600
±.10141204801825835072054170316800	±.20282409603651670144108340633600	±.40564819207303340288216681267200
±.20282409603651670144108340633600	±.40564819207303340288216681267200	±.81129638414606680576433362534400
±.40564819207303340288216681267200	±.81129638414606680576433362534400	±.162259276832213361152866725068800
±.81129638414606680576433362534400	±.162259276832213361152866725068800	±.324518553664426722305733450137600
±.162259276832213361152866725068800	±.324518553664426722305733450137600	±.649037107328853444611466900275200
±.324518553664426722305733450137600	±.649037107328853444611466900275200	±.1298074214577066889222933800550400
±.649037107328853444611466900275200	±.1298074214577066889222933800550400	±.2596148429154133778445867601100800
±.1298074214577066889222933800550400	±.2596148429154133778445867601100800	±.5192296858308267556891735202201600
±.2596148429154133778445867601100800	±.5192296858308267556891735202201600	±.10384593716616535113783470404403200
±.5192296858308267556891735202201600	±.10384593716616535113783470404403200	±.20769187433233070227566940808806400
±.10384593716616535113783470404403200	±.20769187433233070227566940808806400	±.41538374866466140455133881617612800
±.20769187433233070227566940808806400	±.41538374866466140455133881617612800	±.83076749732932280910267763235225600
±.41538374866466140455133881617612800	±.83076749732932280910267763235225600	±.166153499465864561820535526470451200
±.83076749732932280910267763235225600	±.166153499465864561820535526470451200	±.332306998931729123641071052940902400
±.166153499465864561820535526470451200	±.332306998931729123641071052940902400	±.664613997863458247282142105881804800
±.332306997863458247282142105881804800	±.664613997863458247282142105881804800	±.132922799572691648576428421773609600
±.664613997863458247282142105881804800	±.132922799572691648576428421773609600	±.265845599145383297152856843547219200
±.132922799572691648576428421773609600	±.265845599145383297152856843547219200	±.531691198290766594305713687094438400
±.265845599145383297152856843547219200	±.531691198290766594305713687094438400	±.1063382396581533188611427374188876800
±.531691198290766594305713687094438400	±.1063382396581533188611427374188876800	±.2126764793163066377222854748377753600
±.1063382396581533188611427374188876800	±.2126764793163066377222854748	

INPUT TO TRANSISTOR



BASE VOLTAGE



EMITTER VOLTAGE

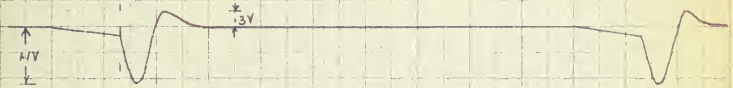

COLLECTOR VOLTAGE (OUTPUT)

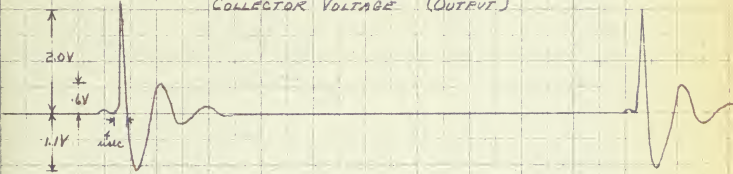

FIG. 13 WAVEFORMS WITH SAWTOOTH INPUT TO TRANSISTOR
BLOCKING OSCILLATOR

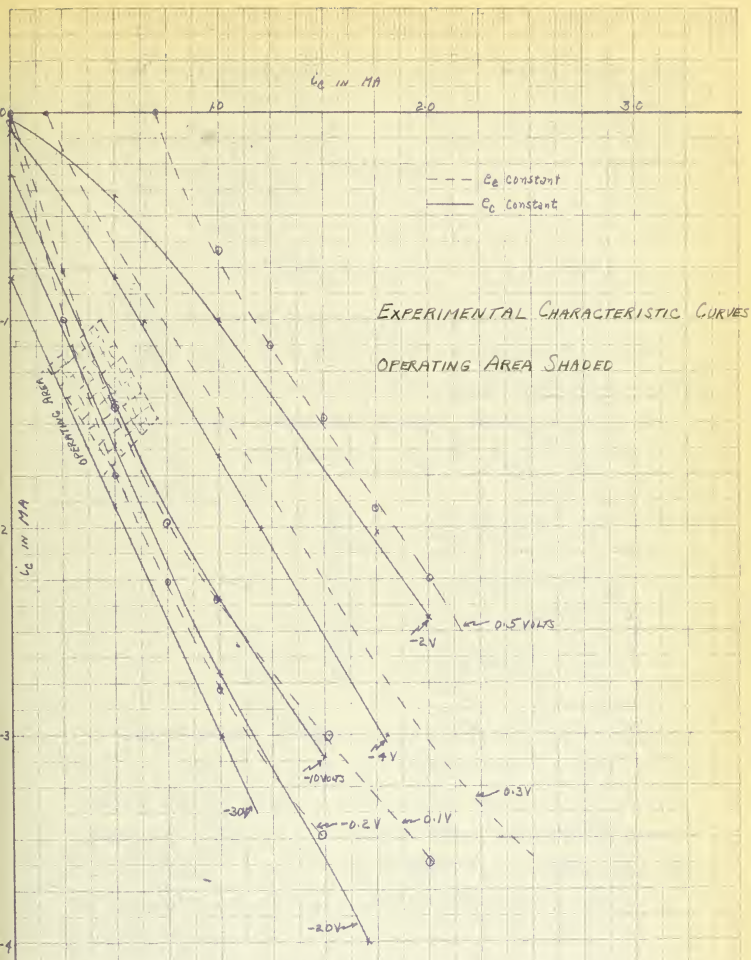

FIGURE 14

For small increments of voltage and current (small signal operation), the incremental operation of the transistor may be expressed by any of a number of equation pairs.⁵ The following pair is convenient for this analysis:

$$E_e = R_e I_e + R_{ce} I_c \quad (1)$$

$$E_c = R_{ec} I_e + R_c I_c \quad (2)$$

The values of R_e , R_{ce} , R_{ec} and R_c in Eq. (1) and Eq. (2) for a given region of operation may be determined from the characteristic curves and from more direct measurements, using methods similar to those used in determining the value of μ , r_p and g_m for a vacuum tube. R_e , R_c , R_{ce} and R_{ec} may be written as follows:

$$R_e = \frac{\partial E_e}{\partial I_e}, \quad i_c \text{ constant} \quad (3)$$

$$R_c = \frac{\partial E_c}{\partial I_c}, \quad i_e \text{ constant} \quad (4)$$

$$R_{ce} = \frac{\partial E_e}{\partial I_c}, \quad i_e \text{ constant} \quad (5)$$

$$R_{ec} = \frac{\partial E_c}{\partial I_e}, \quad i_c \text{ constant} \quad (6)$$

Typical values of R_e , R_c , R_{ec} and R_{ce} , found by using Eq. (3) through Eq. (6) and the characteristic curves, in the normal operating range of a transistor are $R_e = 1400$, $R_c = 33,000$, $R_{ce} = 700$ and $R_{ec} = 77,000$ ohms. These values are similar to those shown for transistors in the BSTJ, July 1949, for the emitter input type circuit (analogous to grounded grid vacuum tube circuit).

Consider the transistor connected in the circuit shown below:

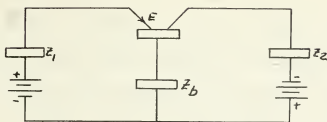

Fig. 15 Basic Oscillator Circuit.

The batteries B_1 and B_2 are of such voltage that they cause the transistor to operate in the desired region of Fig. 14.

The two incremental mesh equations for the circuit of Fig. 15 are written by inspection as follows:

$$(Z_1 + R_e + Z_b) I_e + (R_{ce} + Z_b) I_c = 0 \quad (7)$$

$$(R_{ec} + Z_b) I_e + (Z_2 + R_c + Z_b) I_c = 0 \quad (8)$$

In order that these two equations have a solution other than a trivial one of $I_e = I_c = 0$, the determinants of the equation must equal zero. ⁵ Hence,

$$\begin{vmatrix} Z_1 + R_e + Z_b & R_{ce} + Z_b \\ R_{ec} + Z_b & Z_2 + R_c + Z_b \end{vmatrix} = 0 \quad (9)$$

and

$$(Z_1 + R_e + Z_b) (Z_2 + R_c + Z_b) - (R_{ec} + Z_b) (R_{ce} + Z_b) = 0 \quad (10)$$

$$Z_b = \frac{(Z_1 + R_e) (Z_2 + R_c) - R_{ec} R_{ce}}{R_{ec} + R_{ce} - (Z_1 + R_e) - (Z_2 + R_c)} \quad (11)$$

If stable oscillations are to occur, eq. (11) must be

satisfied at the desired real frequency and at no other point in the complex frequency plane.

The circuit⁶ of Fig. 16 is one circuit suggested by Eq. (11) which when tried gave stable oscillations. It appeared to provide the most satisfactory operation. The circuit oscillates at the parallel resonant frequency of the tuned circuit, i.e., the frequency at which the circuit appears as a pure resistance of magnitude approximately given by $\omega L_S Q$.

The sizes of R_1 and R_2 are not critical over a wide range since the transistor limits (in a manner similar to vacuum tubes) the oscillation amplitude by means of nonlinearities, which adjust the values of R_c , R_{ce} , R_{ec} and R_c .

Caution should be observed in making R_1 or R_2 too small or in letting the DC resistance of the parallel resonant circuit become too great; otherwise the transistor will become DC unstable and be damaged by excessive currents.

When the values of $R_1 = 2500$ and $R_2 = 5000$ ohms are substituted in Eq. (11), a value of 2,600 ohms is obtained for Z_b . This value of Z_b , or greater, is readily obtainable by a parallel resonant circuit which has reasonable values of Q and L/C .

$$Q = \frac{\omega_o L_S}{R_S} \quad \text{or} \quad R_S = \frac{\omega_o L_S}{Q} \quad (12)$$

$$R_p = R_S(Q^2 + 1) = \frac{\omega_o L_S}{Q}(Q^2 + 1) = \omega_o L_S Q + \frac{\omega_o L_S}{Q} \quad (13)$$

The variable inductance in this circuit had a Q of approximately 9 at the oscillation frequency of 9.5 Kc. The DC resistance

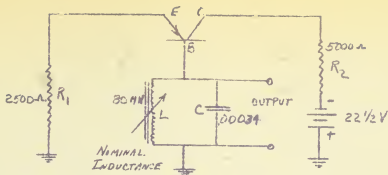

FIG. 16

CIRCUIT DIAGRAM OF TRANSISTOR OSCILLATOR (AUDIO)

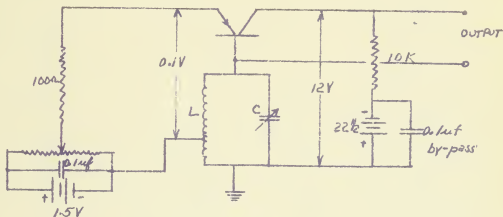

FIG. 18

FIVE MEGACYCLE TRANSISTOR OSCILLATOR

TOLERANCE UP TO ABOVE ABOVE 6 6 TO 24 24 ±.005 ±.010 ±.015 IM. ± 1 ± 1 ± 1 64 32 15 OTHERWISE SPECIFIED	MATERIAL	TITLE			
	FINISH	ISSUED	USED WITH	APPD	DWN.

FIG. 17 FREQUENCY AND AUDIO OUTPUT VS D.C. SUPPLY VOLTAGE

RMS OUTPUT IN VOLTS

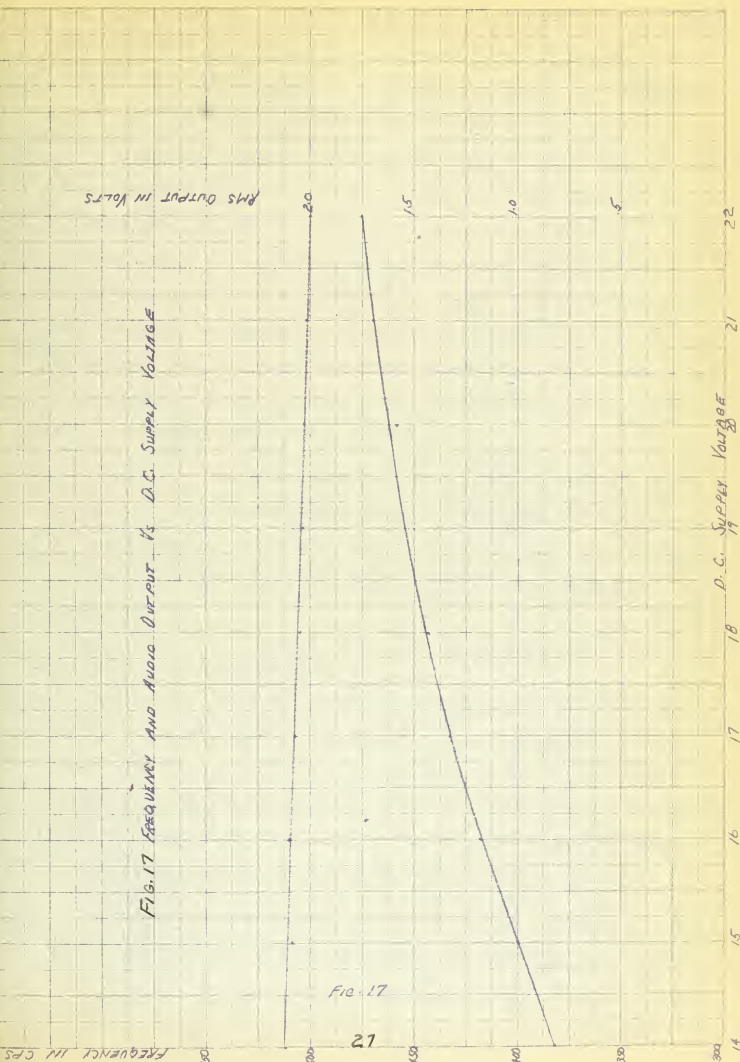

FIG. 17

27

FREQUENCY IN CPS

5500

2000

9511

946

930

14

15

16

17

18

21

22

D.C. SUPPLY VOLTAGE

may be easily made much smaller than 2600 ohms so that DC stability is assured. The variation of frequency and audio output with DC supply voltage is shown in Fig. 17.

A circuit capable of oscillating up to 5 megacycles is shown in Fig. 18. The coil inductance was 5 microhenries at 3.95 megacycles and it resonated on the Q meter with 380 micromicrofarads. The peak-to-peak value of the output was 5 volts rms on the RCA 10 megacycle scope. Oscillations occurred when emitter battery voltage was 1.4 volts and C was 380 micromicrofarads. When additional capacity was added (up to 1000 micromicrofarads), the circuit still oscillated but the emitter voltage had to be decreased.

The inductance was tapped so as to match the input impedance of the transistor which was approximately 500 ohms. It was noted that the frequency of oscillation was a function of both the emitter and collector voltages as well as the capacitor.

3. High Frequency Amplifier.

One of the limitations of the transistor is its high frequency response. Becker and Shive⁷ showed that useful transistor performance is limited to frequencies below about ten megacycles. The comparative ease of measurement of the current amplification factor "a", since it is a ratio of two alternating currents, causes it to be studied in detail. (See Fig. 19).

Approximate measurements of the individual elements of the equivalent circuit, Fig. 2, showed Z_e , Z_c , and Z_b are reasonably

WATER LOSS, PER CENT

100%

100%

WATER LOSS, PER CENT

100%

100%

WATER LOSS, PER CENT

FIG. 18. Comparison of the effect of water loss on the rate of water loss.

constant up to at least ten megacycles. However Z_m changes with frequency and causes the current amplification factor to drop off at approximately one megacycle. This variation of Z_m with frequency can be attributed to a transit-time dispersion associated with the interaction between emitter and collector currents.

In support of this, an attempt was made to measure input, output and emitter-to-collector capacities of a transistor amplifier. In each case the capacity was less than one micro-microfarad. This would indicate that the falling off of gain at high frequencies is primarily due to the physics of the transistor.

The basic action by which a transistor amplifies is as follows: The collector is operated at a high negative voltage, i.e., 10 to 50 volts. Most of this potential drop takes place within a very small region around the collector contact, by reason of the barrier layer which impedes the flow of electrons from metal to the semiconductor. Holes are injected at the emitter at a low voltage (0.03 to 0.3 volt) and under the influence of the field due to collector current move to the collector, where they lower the barrier layer height, causing an increase of collector current.

It becomes apparent that the transit time between the emitter and collector will be controlled by the internal field strength in the crystal. Since the collector current is large compared to the emitter current, the field strength will largely be a function of the resistivity of the germanium

and the collector current. Bardeen⁸ presented a theoretical relationship from which

$$T = \frac{2 \pi S^3}{3 U_h \rho I_c}$$

where T = transit time, S = spacing, U_h = hole mobility, ρ = resistivity and I_c = collector current. An examination of the geometry of the type -A transistor shows that since all holes do not flow over paths of the same length, a dispersion in transit time results in a diffuse transit angle. This has the result of reducing the average value of collector modulation and is the primary cause for loss of high-frequency response.

From the equation above, it is seen that the most important element in determining frequency response of type A transistor is the spacing since it appears as a cubic function. The spacings are taken from center to center of the electrodes, which are approximately one mil in diameter. Spacings less than 2.5 mils are not usable in the present design of transistors and it is evident that high-frequency operations require the use of minimum practical separations.

Since the internal field strength, accelerating the holes from the emitter to the collector, is proportional to collector current it would appear desirable to use the highest practical collector current. It has been found experimentally that currents of about 5 mils are the maximum values that can be used without introducing instability due to overheating of the collector contact.

A variable in the transit-time equation that has not been well controlled in presently manufactured transistors is the bulk resistivity, ρ .

From the foregoing discussion, it is seen that the requirements for a high-gain, high-frequency transistor are small emitter-collector spacings, small contact areas, high bulk resistivity and operation at the highest practical collector current.

A recently discovered method⁹ of extending the high frequency range consists of applying a magnetic bias of the proper sign at right angles to the plane of the collector and emitter. This field acts in such a manner as to beam the emitter and collector currents along a more direct path. While it does reduce the transit time, it also reduces the transit angle dispersion and thus increases the frequency range.

It has been found that transistors having wide spacings show larger increases in "a" than those with small spacings. Also transistors having small contact areas show higher values of "a" when magnetically biased. Thus the magnetic bias not only increases "a" at high frequencies but also decreases the variation between transistors.

The circuit representation of the transistor at high frequencies can be obtained using a three-terminal network having one generator as shown in Fig. 20, where Z_e is the input resistance, Z_o the coupling resistance and Z_c the collector resistance. C_c is the barrier-layer capacitance (less than 1 micromicrofarad) and C the emitter-collector contact

capacitance (1 micromicrofarad). The generator current may be represented by i_1 , a_f , ϕ_f , Z_c , where i_1 is the a.c. input current, a_f the short-circuit current gain at frequency f , and ϕ_f is the phase shift with frequency f .

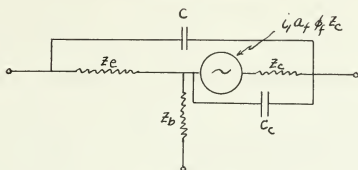

Fig. 20. Three terminal representation of transistor at high frequencies.

It is evident that the input impedance will depend largely on the load current through Z_b . At low frequencies this current is opposed to the input current i_1 , and acts as positive feedback. At higher frequencies the phase shift in "a" causes the input impedance to become complex and at very high frequencies phase shifts of nearly 180 degrees will increase the input impedance. It should be remembered that complex load impedances obtained when tuned collector circuits are used will alter this condition. The collector impedance likewise can vary greatly due to feedback. At low frequencies this positive feedback characteristic of a transistor reduces the collector impedance but at higher frequencies it becomes dependent on the input impedance which may be complex if tuned inputs are used. The coupling resistance Z_b does not change much with frequency but it is a function of both emitter and collector current.

From the foregoing, it is apparent that care must be taken at low frequencies to insure sufficiently high input and output impedances to reduce the positive feedback. Much of the lack of d-c stability can be traced to inadequate coupling impedances. It is desirable to have both input and output impedance high at all frequencies both in and outside the amplifier passband; but some compromises must be in order to obtain sufficient gain.

Fig. 21 shows the circuit diagram for a 23-mc amplifier used for testing high frequency response of transistors. It is a grounded-base circuit which is analogous to the grounded-grid triode behavior described previously. Shunt feed of both emitter and collector currents is used to insure high d-c stability. Since the emitter current is only 0.4 ma, it is possible to use a high value of emitter bias coupling resistance without unduly high bias voltage. In the collector network, L_1 , C_1 , L_2 , C_2 constitute a band pass whose impedance is high at frequencies in the pass-band and also remote from the pass-band. There are minima however on both sides, and some difficulty may be encountered if overall phase shifts are such as to satisfy the conditions for oscillation.

Transistor amplifiers should always be designed for high impedance outputs, tapping the diode down on L_2 to meet the requirements for diode load resistor matching. Since the emitter is a current-fed element, the input impedance must be kept low at the frequency of amplification and high at all others. This can be satisfied in most cases with a series tuned input

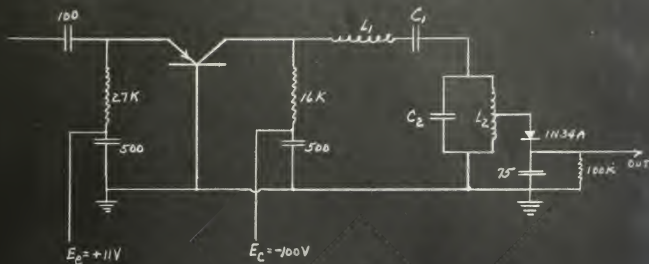

All capacitances in μmf

FIG. 21. Circuit of 23mc amplifier used for testing high frequency response of transistors

TOLERANCE UP TO ABOVE ABOVE 5 6 TO 24 24 M. $\pm .005$ $\pm .010$ $\pm .015$ DIM. $\pm \frac{1}{64}$ $\pm \frac{1}{32}$ $\pm \frac{1}{16}$ UNLESS OTHERWISE SPECIFIED	MATERIAL		TITLE			
	FINISH		ISSUED	USED WITH	AP'PD	DWN.
Federal Telecommunication Laboratories, Inc.			-1			

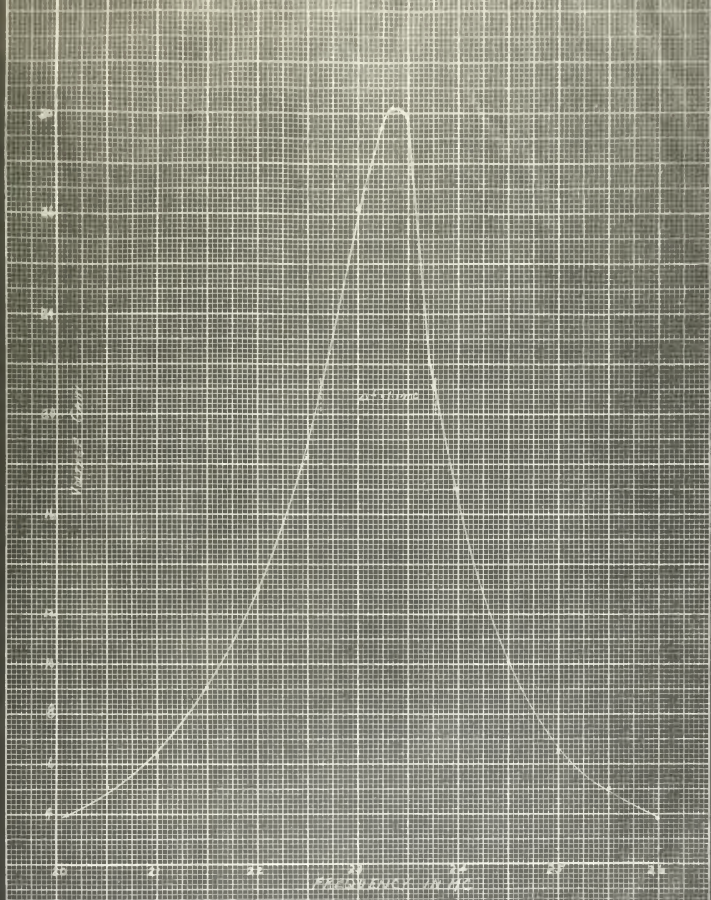

Fig. 26. Attenuation characteristics of a line amplifier.

network if necessary to prevent oscillation at frequencies outside the pass-band.

Fig. 22 shows the frequency response of the amplifier. The input impedance is approximately 1,000 ohms at 23 mc. The output impedance of L_2C_2 is 16,000 ohms, thus the gain between 1,000 ohm input and output would be 8. This results in a gain bandwidth of 8.8 mc. since the bandwidth is 1.1 mc. as obtained from frequency response curve. The small magnet used here gives a field strength of 16,000 lines per square inch. Slightly higher gain could have been attained if more field strength were available.

The stability with time is very good. No changes in gain of more than 5 percent occurred for any given transistor over a period of several weeks of operation. The emitter voltages are not critical and can be varied 30 percent with little change in gain. The collector voltage controls the gain by varying the collector current and hence this voltage must be regulated to the same extent to which it is desired to hold the gain. This shows that a. v. c. in this type of amplifier may be obtained by control of this voltage through auxiliary circuits.

CHAPTER III

Conclusions.

The advantages of transistors over vacuum tubes include their extreme simplicity, ruggedness, small size, low supply voltages, absence of filament power supply with resultant less heat dissipation, economy of power and long life expectancy. The disadvantages are poor quality control at the present time, low power capabilities, short circuit instability which is advantageous in oscillators, low frequency response, high noise and the critical value of emitter voltage in the blocking oscillator circuit.

Manufacturing techniques are improving and should conquer the quality control problem while the development of techniques to increase the upper frequency limit have been shown to indicate the elimination of this limitation. The major drawback which limits the usefulness of the transistor is its inability to handle power exceeding a fraction of a watt. It is hoped that those working on the development of the transistor will find ways to improve its power handling capacity.

The results of this investigation show that it is possible to build blocking oscillator circuits using transistors of current manufacture. To achieve maximum reliability, however, it is necessary to select carefully only the units with favorable characteristics. Then each circuit must be fitted to the individual transistor. A great source of trouble in this investigation was due to the inability to determine the char-

acteristics of the transistor, i.e., whether it would operate as an oscillator, amplifier, etc. The transistor that worked as a blocking oscillator showed poor amplifying characteristics.

The transistor, like the vacuum tube, was first conceived in the communications industry and like the vacuum tube, its application to fields outside the communications industry may be anticipated. For these applications two characteristics stand out and seem to provide the possibility of performance not inherent in the vacuum tube. First, the transistor should have an indefinitely long life because it has no heated cathode; and second, it is possible to make the transistor mechanically rugged. The Signal Corps Labs have shown in shock tests of up to 10,000 g's that the point contacts of the transistor will withstand this force without mechanical injury.

There are many commercial applications for a device possessing the characteristics of a vacuum tube which the vacuum tube, as it exists today, does not satisfy simply because it has a filament or heater which is subject to burnout. An example of this is certain types of switchgear used in the distribution of electric power. Tubes are not used because reliability is of prime importance.

The transistor is currently being tested in some commercial lines of the Bell System but data is not available to the general public. Its use in counters is currently under development for the military forces. The possibility for military applications are numerous and studies and exploratory contracts are in existence.

BIBLIOGRAPHY

1. Bardeen, J. and Brattain, W. H., "The Transistor- A Semi-Conductor Triode". Physical Review V. 74, p 230-231, July 15, 1948.
2. Bardeen, J. and Brattain, W. H., "Physical Properties Involved in Transistor Action". Bell System Technical Journal V. 28, p 239-277, April 1949.
3. Ryder, R. M. and Kircher, R. J., "Some Circuit Aspects of the Transistor". Bell System Technical Journal V. 28, p 367-400, July 1949.
4. Webster, W. M., Eberhard, E. and Barton, L. E., "Some Novel Circuits for the Three Terminal Semi-Conductor Amplifier". RCA Review, p 5-16, March 1949.
5. Guillemin, E. A., "Communication Networks". Vol. 1, p 174, John Wiley and Sons.
6. Lehan, F. W., "A Transistor Oscillator for Telemetering". Jet Propulsion Lab. Cal. Tech. Memo. 4-48, Feb. 16, 1949.
7. Becker, J. A. and Shive, J. N., "The Transistor- A new Semi-Conductor Amplifier". Elec. Engr. V. 68, p 215-223, March 1949.
8. Bardeen, J. and Brattain, W. H., "Transistor Action". Physical Review V. 75, p 1225, April 15, 1949.
9. Brown, C. B., "Magnetically Biased Transistors". Physical Review V. 76, p 1736, Dec. 1, 1949.
10. Brown, C. B., "High Frequency Operation of Transistors". Electronics p 81-83, July 1950.



OCT	7		210
OCT	40	RENEWED	
OCT	31	RENEWED	
DEC	23		231
FEB	4		539
MAR	13		22
JUN	8		811
AUG	25		

Thesis		15565
C186		
Calabrese		
Applications and		
uses of transistors		
FEB	4	539
MAR	13	22
JUN	8	811

thesC186

Applications and uses of transistors.



3 2768 002 08434 5

DUDLEY KNOX LIBRARY