



Calhoun: The NPS Institutional Archive
DSpace Repository

Theses and Dissertations

1. Thesis and Dissertation Collection, all items

1970

Dynamic depth perception.

Rolstad, Lawrence Arian

Monterey, California ; Naval Postgraduate School

<https://hdl.handle.net/10945/14961>

Downloaded from NPS Archive: Calhoun



Calhoun is the Naval Postgraduate School's public access digital repository for research materials and institutional publications created by the NPS community. Calhoun is named for Professor of Mathematics Guy K. Calhoun, NPS's first appointed -- and published -- scholarly author.

Dudley Knox Library / Naval Postgraduate School
411 Dyer Road / 1 University Circle
Monterey, California USA 93943

<http://www.nps.edu/library>

DYNAMIC DEPTH PERCEPTION

Lawrence Arian Rolstad

United States
Naval Postgraduate School



THE SIS

Dynamic Depth Perception

by

Lawrence Arian Rolstad

April 1970

*This document has been approved for public re-
lease and sale; its distribution is unlimited.*

T133759



Dynamic Depth Perception

by

Lawrence Arian Rolstad
Major, United States Marine Corps
B.S., University of Washington, 1959

Submitted in partial fulfillment of the
requirements for the degree of

MASTER OF SCIENCE IN OPERATIONS RESEARCH

from the

NAVAL POSTGRADUATE SCHOOL

ABSTRACT

A review of research in visual acuity and depth perception of moving objects disclosed differing estimates of the relation between dynamic and static vision performance. Additionally, two distinct types of responses appear in distance estimates for moving targets as well as the elapsed time estimates for partially concealed targets. The possible relation of this depth estimation error dichotomy to lateral phoria is discussed. An experiment demonstrates that the depth estimation error dichotomy, if it exists, is not related to phoria and is independent of the direction of target motion. Further evidence of the lack of correlation between dynamic and static depth perception is presented.

TABLE OF CONTENTS

I.	INTRODUCTION- - - - -	5
II.	DYNAMIC VISION RESEARCH - - - - -	10
III.	AN EXPERIMENT IN DYNAMIC DEPTH PERCEPTION - - -	22
IV.	DATA ANALYSIS - - - - -	29
V.	CONCLUSIONS - - - - -	38
	APPENDIX A. DATA AND ANALYSES OF VARIANCE - - - - -	42
	LIST OF REFERENCES - - - - -	45
	INITIAL DISTRIBUTION LIST - - - - -	47
	FORM DD 1473 - - - - -	49

I. INTRODUCTION

Dynamic depth perception is the ability of the eye to perceive the distance of a moving object. Dynamic depth perception is probably a very useful tool for creatures that swing from trees. However, as Man's ancestors began to walk on the ground the necessity to estimate the distance of high velocity objects diminished. To be sure, dodging rocks or swatting at flies required judging the distance of a moving object, but that is a bit less critical than brachiating through the trees.

Today, almost every person finds judging the distance of moving vehicles a matter of life and death, either as an operator or as a possible target. Relative motion and relative distance are very important to pilots in both formation flying and avoiding other aircraft near terminals. With the advent of holography, controllers of traffic flows or complex processes may be required to judge relative motion and distances in three-dimensional displays. Discussing dynamic visual acuity, Burg states, ". . . discrimination of moving objects (or of stationary objects while one is moving) plays a key role and, therefore, . . . performance on a dynamic-acuity test may be more closely correlated with task performance than is the score obtained on a test of static (or standard) acuity." (Burg, 1966.)

How does depth perception work and how does it differ in the dynamic and static modes? The perception of depth

comes from a number of secondary or monocular cues: size, brightness, texture, perspective, interposition of objects, and parallax. The actual sensation of depth, the feeling of space, comes from the primary or binocular depth cues, convergence and accommodation, and binocular disparity. Accommodation and convergence are thought to give rise to a depth sensation through proprioceptors in the muscles of the eye. As the eyes converge and focus on different objects the muscle movement is sensed and interpreted as depth. Binocular disparity refers to the different position of an object's image on the retina of each eye, this difference in position being translated by the brain into a depth sensation. It is not certain if the depth sensation is learned or inherent.

There is no pressing need for binocular vision as a one-eyed person can get along quite comfortably without the sensation of depth. This is confirmed by experimental evidence showing that monocular cues are the most important, (Dember, 1963, p. 175). Perhaps that is why most experiments are designed to explore only the secondary cues. Ogle (1962) points out that the secondary cues to depth perception are the strongest and most easily learned. However, in the absence of secondary cues, the disparity of the two images of an object in the eyes is the primary cue. Ogle tends to discount accommodation and convergence as giving much depth information since that implies depth is a proprioceptive sensation. There is little laboratory evidence to support

this implication. The sensitivity of the eyes to depth is extremely sharp compared with the proprioceptive senses. Also, depth perception tests involving only accommodation and convergence show very poor results.

Thus, the factors most readily studied in dynamic depth perception appear to be the secondary cues. The depth perception experiments to be discussed in the next chapter use black rods against an illuminated background. This means relative size is the only secondary cue present. This is much the same situation as in a visual acuity test. That is to correctly discern the gap in a Landolt C-ring or clearly distinguish a letter on a Snellen chart is the same problem as focusing on two rods clearly enough to compare their apparent widths. Consequently, we can make some degree of comparison between experiments dealing with dynamic visual acuity and those with dynamic depth perception.

This brings up the problem of what a visual acuity test measures. Visual acuity used to be thought of as the degree of precision with which the eye focused an image on the fovea. Those with good acuity had a sharp, stable image on the back of each eye. It has since been discovered that the image is anything but stable. The eye when looking at an object exhibits a constant, tiny, fluttering motion called nystagmus, larger jerks or saccadic movements, and slow drifts. If the image is artificially stabilized on the retina it gradually disappears (Dember, 1963, p. 148). It is surprising that the eye's acuity is as good as it is since the

eye is not light-tight around the lens and the quality of the light coming through the lens is blurred and colored (Geldard, 1963, p. 86). Another problem with the traditional concept of acuity is that the number, size, and spacing of the cones in the fovea is respectively, too few, too large, and too far apart to account for the degree of resolution the eye can achieve.

The eye apparently sees by means of some integrating process using a constant scanning pattern to stimulate the cones and rods. If the light intensity does not vary for a cone there will be no signal and no vision, thus an image disappears when stabilized on the retina by means of some device. In this situation the borders of an image are most important and the border is "seen" by the contrast of light intensity in the fovea. The actual pattern of the image on the fovea is a large blur having the general shape of the object. The width of the blur and the central area of unstimulated cells is related to the size of the object.

A factor that may affect dynamic depth ability is lateral phoria or "bearing" of the eye. An individual's eyes almost never look in the same direction when at rest or unfocused. The actual direction of the eye's axis determines the type of lateral phoria measured in degrees. If the eyes look away from each other, they are exophoric, if they look inward, they are esophoric. This does not imply actual cross-eyed vision in the case of the esophoric or wall-eyed in the case of the exophoric since the eyes focus normally. The

few individuals whose eyes are both in line are called orthophoric.

Considering the normal movements of the eye it is surprising that we should need to investigate vision in the dynamic mode since the image is never motionless. Interest in dynamic visual acuity was first stimulated by curiosity about the speed at which a moving object became invisible. Visual acuity for the moving eye disappears well below the limits of the eye muscles' movement ability. The eye can move voluntarily at about 600 degrees per second (Ludvigh and Miller, 1958) and some of the involuntary movements are as high as 1000 degrees per second (Alpern, 1967, p.60).

Thus it is apparent that the motion of an object does seem to make a difference in the ability to perceive it. Several experimentors have directly or indirectly investigated dynamic depth perception. They differ in their interpretations of the relationship of depth perception and visual acuity between dynamic and static modes. This thesis will first review their work, explore the questions raised through further experimentation, and discuss and extrapolate on the results.

II. DYNAMIC VISION RESEARCH

While much interest has been devoted to studying visual acuity and depth perception in relation to stationary targets, little research has been directed towards dynamic vision effects. Apparently earlier workers touched only incidentally upon dynamic vision, being more interested in light and color. Most of the work in dynamic vision will be summarized in this chapter.

Astronomers had noted an unexplained movement of star images when stereoscopic plates of stars were quickly moved laterally in a stereocomparator. The star's image seemed to move either towards or away from the observer. Pulfrich discovered that the apparent movement was caused by a difference in brightness between the two star plates (Lit, 1949). The effect was termed the Pulfrich stereophenomenon.

This illusion can be demonstrated by observing any laterally oscillating object such as a pendulum while one eye is covered by some type of filter. The object will appear to be moving in a circular path instead of in the frontoparallel plane. If the filter is over the left eye the object will move clockwise, the direction of rotation reversing when the filter is switched to the other eye. The phenomenon appears above some threshold filter density and disappears when the eyes can no longer perceive binocularly. For the more detailed description on which the above is based, see Lit (1949).

A visual latency period was hypothesized which essentially required that the eye receiving the filtered image delay transmitting the image to the brain. Lit conducted a series of experiments exploring this visual latency period under varying filter and target conditions (Lit, 1949, 1960a, 1960b, 1964). Of more interest is the fact that Lit also reported a depth perception disparity when the observer had no filter covering an eye.

In Lit's apparatus, the observer saw two vertical black rods in a laterally elongated rectangular window, one rod extending halfway into the rectangle from below, the other in like fashion from above. The upper rod oscillated laterally while the lower rod could be moved by the observer either towards or away from him. Under conditions of equal retinal illumination the oscillating rod appeared displaced from the actual plane of vibration. This depth perception phenomenon, which Lit related to other reports (Lit, 1949, p. 179) appeared to be associated with the observer's type of lateral phoria. For an exophoric observer, the oscillating rod seemed displaced further away than the actual plane of movement. For an esphoric observer the oscillating rod appeared closer. The magnitude of the near displacements were larger than the magnitude of the far displacements.

Lit's observations were at relatively slow lateral angular velocities, a maximum of 39 degrees per second and only used two or three observers. Other investigators studied the dynamic mode of the eye over a wider range of experiments on

dynamic visual acuity, as they termed it, using flight students at the U.S. Naval School of Aviation Medicine (Ludvigh and Miller, 1958, Miller, 1958). The targets used were Landolt C-rings on a white screen. The subject monocularly viewed the target in a rotating front-surface mirror driven by a variable speed motor.

Ludvigh and Miller allowed the eye to track the target before focusing in an attempt to stabilize the image. The mirror was masked so that the target could be track a total of .4 seconds at any angular velocity. For the first .2 seconds the target was blurred and for .2 seconds the target could be seen clearly. The acuity threshold datum was the smallest Landolt C-ring that could be correctly identified at a given target velocity. Static acuity was measured monocularly by Snellen eye chart.

In many tests, some cumulatively involving over a thousand subjects, Ludvigh and Miller were able to show that monocular visual acuity decreases with increasing target velocity. They fitted the dynamic threshold data to the curve $Y = a+bx^3$, where x is the angular velocity in degrees per second, a is some measure of static acuity, and b is a measure of dynamic acuity. Unfortunately, they were not able to find a significant relationship between a and b , that is there was no significant correlation between dynamic and static acuity. They concluded that static acuity performance could not predict dynamic acuity (Ludvigh and Miller, 1958, p.801).

Ludvigh and Miller also discussed three possible factors contributing to the loss of dynamic acuity; the inability of the eye to move fast enough, the location of the image outside of the fovea due to imperfect tracking movements, and the motion of the image on the fovea. The eye's movement capabilities have already been discussed and seem much greater than the range of the experiment, 170 degrees per second. A subsidiary experiment conducted by Ludvigh and Miller seems to indicate that the loss of acuity away from the fovea is not a major factor, although greater acuity drops have been reported (Rawlings and Shipley, 1969). They explained the loss of acuity as due to "imperfect pursuit movements of the eye, [which] although maintaining the image in the immediate vicinity of the fovea, never-the-less result in a motion of the image on the retina which reduces visual acuity" (Ludvigh and Miller, 1958, p.802). The effect of this motion would be to reduce the intensity of the image on the retina, the fact that acuity increases with increasing illumination for both static and dynamic targets supports the hypothesis (Miller, 1958, p.808).

Burg (1966) attempted to resolve the conflict between researchers, such as Ludvigh and Miller, who found little relationship between dynamic and static acuity and those who, like Burg and Hurlbert (1961), found low but significant correlations between dynamic and static acuity. Burg felt that a large heterogenous sample might show more consistency than the small, restricted samples of previous researchers.

His apparatus was essentially a slide projector, rotating left to right, which threw images of an Orthorater checker-board pattern on a large circular screen (Burg, 1965). The subjects' static visual acuity was measured in a standard Orthorater and on the screen. Dynamic acuity was measured at 60, 90, 120, and 150 degrees per second. Over 6000 drivers were given all treatments with some parts of the test being given to as many as 17,000 drivers. Burg concluded that:

"1. Visual acuity for a moving target is poorer than that for a stationery target, and acuity becomes progressively worse with increasing angular velocity of target movement.

2. There is a progressive decline in acuity with advancing age, this decline accelerating in the older age groups and becoming more pronounced with a moving target than with a stationary target.

3. Males have a slight but consistent superiority over females with regard to visual acuity threshold (whether static or dynamic).

4. High intercorrelations exist between all acuity tests, with the correlations between static and dynamic tests decreasing (as expected) with increasing target velocity. Also as expected, the static-screen acuity test correlates more highly with the dynamic tests than with the Orthorater." (Burg, 1966, p.464). Table 2.1 shows Burg's correlation coefficients.

Table 2.1

Correlations between Dynamic and Static Visual Acuity

		Static	Dynamic			
Target Motion		0°	60°/sec	90°/sec	120°/sec	150°/sec
Static	Orthorater	.673	.598	.541	.499	.350
Settings	0°		.710	.634	.565	.452
Dynamic	60°/sec			.788	.695	.591
Settings	90°/sec				.765	.660
	120°/sec					.697

(Adapted from Burg, 1966, p.464)

Weissman and Freeburne (1965) were dissatisfied with the disparity between correlations in findings by Burg, on the one hand, and Ludvigh and Miller on the other. In addition, they wished to test for non-linear relationships between dynamic and static acuity. Their dynamic visual acuity experiment duplicated Burg's apparatus with Landolt C-rings as targets. A group of women college students were tested for dynamic visual acuity at target velocities up to 180 degrees per second.

Weissman and Freeburne found high correlations between static and dynamic acuity at the slowest speed. Their correlation data is reproduced in Table 2.2 and shows a decreasing relation between dynamic and static acuity as angular velocity increases. Their attempt to find functional relationships in the data was not successful.

Table 2.2

Dynamic and Static Visual Acuity Correlations

		Dynamic					
		20°/sec	60°/sec	90°/sec	120°/sec	150°/sec	180°/sec
Target Motion							
Static	0°	.713	.675	.638	.665	.231	.098

(Adapted from Weissman and Freeburne, 1965, p.142)

As Weissman and Freeburne point out, "It may be that the population sampled in this type of experiment is an important factor to consider. With a restricted range of static acuity thresholds, DVA [Dynamic Visual Acuity] thresholds at a wide range of speed would tend to deviate greatly from SVA [Static Visual Acuity] scores [producing low correlations]. On the other hand, at a wide variety of SVA thresholds, the DVA thresholds obtained at the various speeds would tend more to be related to the static acuity thresholds." In other words, the larger the population the more the apparent correlation. They also speculated that the method of taking the static visual tests may have affected the discrepancy in correlations of other workers.

In another research effort, Luria and Weissman (1968) pointed out that while all the above activity was taking place in dynamic visual acuity little was being done to investigate depth perception in the dynamic mode. They reviewed the work by Lit and Hamm (1966) noting the phenomenon mentioned above where the observer apparently sees a displacement of a

laterally vibrating object. Luria and Weissman (1968) decided that stereo depth perception or dynamic stereo acuity (to use their term) needed more research.

Luria and Weissman designed an experiment to investigate the dichotomy of error reported by Lit and to determine the correlation between static and dynamic depth perception. Their apparatus used a left to right rotating arm centered over the observer's eyes, from which were suspended two black rods, with a 3 degree separation. The right rod was fixed and the left rod could be moved towards or away from the observer. The rods, subtending .1 visual degree, could be viewed binocularly by the observer 110 degrees laterally and 9.5 degrees vertically. The task was to estimate the distance of one rod from the observer in relation to the other rod.

For each static and dynamic mode a number of measurements were taken to establish a threshold in terms of the apparent centered position of the variable rod. In one experiment with fifty subjects the viewing time was held constant for .61 seconds. In a second experiment, five viewing times were used on four observers for each of the four angular velocities.

In the first experiment, Luria and Weissman were able to categorize the subjects into two groups, 24 over estimators and 26 under estimators. From the clue in Lit's work, relating lateral phoria to the direction of localization error, Luria and Weissman retested twenty-two of

their subjects for phoria. Of the twenty-two, fifteen subjects had one degree of phoria or greater. A comparison of these subjects' lateral phoria to the type of error is shown in Table 2.3. They noted that there is a close but not perfect relation of phoria to the direction of constant error and that there must be ". . . many other factors involved in this phenomenon, such as individual differences in torsional effects and convergence" (Luria and Weissman, 1968, p. 56).

Table 2.3
Grouping of 15 Subjects by Lateral Phoria
and Direction of Constant Error

	Exophoria	Esophoria
Variable Rod Set Farther	6	1
Variable Rod Set Nearer	1	7

(Adapted from Luria and Weissman, 1968, p.54)

Luria and Weissman also found there was low correlation between the static and dynamic thresholds, as shown in Table 2.4, but high correlations between the various dynamic thresholds. The correlations between the static and dynamic standard deviations in Table 2.5 show little relationship between the variables.

Table 2.4

Depth Perception Correlations for Constant Error

		Dynamic			
Target Motion		60°/sec	90°/sec	120°/sec	180°/sec
Static	0°	.33	.32	.23	.11
Dynamic	60°/sec		.94	.92	.75
	90°/sec			.87	.77
	120°/sec				.84

(Adapted from Luria and Weissman, 1968, p.53).

The second experiment, varying the viewing time, disclosed a sharp increase in the threshold for each of the speeds of rotation below .3 second. This tends to confirm Miller and Ludvigh's using .2 second as the acquisition time for their experiment. Apparently the eye needs this time to commence tracking.

Table 2.5

Correlations for Standard Deviations
of Depth Perception Thresholds

		Dynamic			
Target Motion		60°/sec	90°/sec	120°/sec	180°/sec
Static	0°	.32	.36	.27	.19
Dynamic	60°/sec		.25	.26	.31
	90°/sec			.23	.47
	120°/sec				.32

(Adapted from Luria and Weissman, 1968, p.52)

Luria and Weissman point out the similarity between their results and Lit's: "Both show the increase in error and variability with increasing speed, the split into two directions of the errors and a greater negative than positive error." (Luria and Weissman, 1968, p. 55). They conclude, noting their low static and dynamic stereo acuity correlations along with Weissman and Freeburne's low static and dynamic visual acuity correlations, by questioning the presence of correlation between any dynamic and static visual function.

In a slightly different area of vision investigation, Ellingstad and Heimstra (1969) conducted a velocity-time estimation experiment, varying target speed and concealment. The experimental task required visual tracking of a target as it passed in front of the observer and disappeared from view. The subject then estimated the time the target should arrive at a goal light further along the apparent line of travel.

Unlike the previous visual acuity experiments, the degree of error decreases with increasing target speed. However, the subjects could be divided into two groups--those who over-estimated and those who under-estimated the time for the target to reach the goal light. The groups were furthest apart at the slowest speed showing almost identical results for the fastest target speed, 9 degrees per second. Both groups tended toward the positive side, over-estimation, one group over-estimating at all speeds and one group under-estimating at the slowest speed and crossing over (Ellingstad and Heimstra, 1969). Apart from the

conclusions about their other results, Ellingstad and Heimstra consider several explanations for the bimodal responses evident in their data. One of the possible explanations discussed and rejected for the existence of two types of responses, is the concept of levelers versus sharpeners in the perception of sequences of objects (Holzman and Klein, 1954). They also state, apparently unaware of the work of Luria and Weissman, that "no such patterns of bimodal response have been reported for the perception of real movement."

The preceding review of experiments dealing with the dynamic mode of vision shows that differing opinions have been reached by the investigators. The question of a relationship between dynamic and static acuity has not yet been fully resolved. A massive sample such as Burg's will give statistically significant correlations for very small values, yet this does not imply any workable relationship. Other restricted sample sizes have given mixed results complicated by unconformable methods of measuring static and dynamic acuity.

The two distinct types of responses to dynamic vision stimuli have not yet been definitely related to any vision factor. Phoria seems to be the most likely explanation but the data was only related in those individuals having greater than one diopter of phoria. Any comprehensive explanation for the dichotomous responses apparently present in all subjects should not be restricted to those with greater than one diopter of phoria.

III. AN EXPERIMENT IN DYNAMIC DEPTH PERCEPTION

As discussed in the previous chapter, a connection seems to have been established between the type of lateral phoria and the direction of error in estimating the distance of a moving target. The tendency for an observer is to estimate any moving object at a position slightly closer than its actual distance. Those with esophoric vision place the rod the closest while those with exophoric vision put the oscillating rod further away.

What has not been established is the relation of this depth estimation error to the direction of rotation. In Lit's series of experiments the moving rod oscillated back and forth while in Luria and Weissman's experiment the rods moved in only one direction. The effects reported by Lit may be the result of an averaging process. That is, for motion in one direction an observer underestimates the distance of a moving target and overestimates when the motion is reversed. In this case a reversal of direction in Luria and Weissman's experiment should cause a reversal of results. If, on the other hand, the dichotomy of depth estimation is caused only by target motion and is not dependent on direction, a reversal of direction in Luria and Weissman's experiment should produce the same error for each subject.

To test the above hypothesis - Is the direction of moving target depth estimation error dependent on or independent of the direction of movement? - it was decided to repeat Luria and Weissman's experiment, testing the observer's dynamic depth perception when the rods are rotated in both directions. Circumstances did not permit duplication of Luria and Weissman's apparatus; therefore, a device similar to that used by Ludvigh and Miller was constructed.

It also has not been established that the direction or amount of depth estimation error for moving targets is related to phoria for those subjects with less than one degree of lateral phoria. The following experiment, using an average group of subjects, can explore this problem as well as again determine the correlation between static and dynamic depth perception.

The experimental array is shown in Figs. 3.1 and 3.2. A DC motor (A) rotated a 6 by 12 inch front-surface mirror (B). The targets (C) two black-coated glass rods were seen through an eye slit in the head rest (D). The mirror was masked so that only a 1 inch wide strip was open at eye level. Movements of the head were limited by the semi-circular shape of the head rest; however, glasses could be worn.

The motor was controlled by a DC power source allowing mirror speeds of from 0 to about 40 RPM. The observer's forehead was 8 inches from the center of rotation of the mirror which was in turn 38 inches from the acuity target,

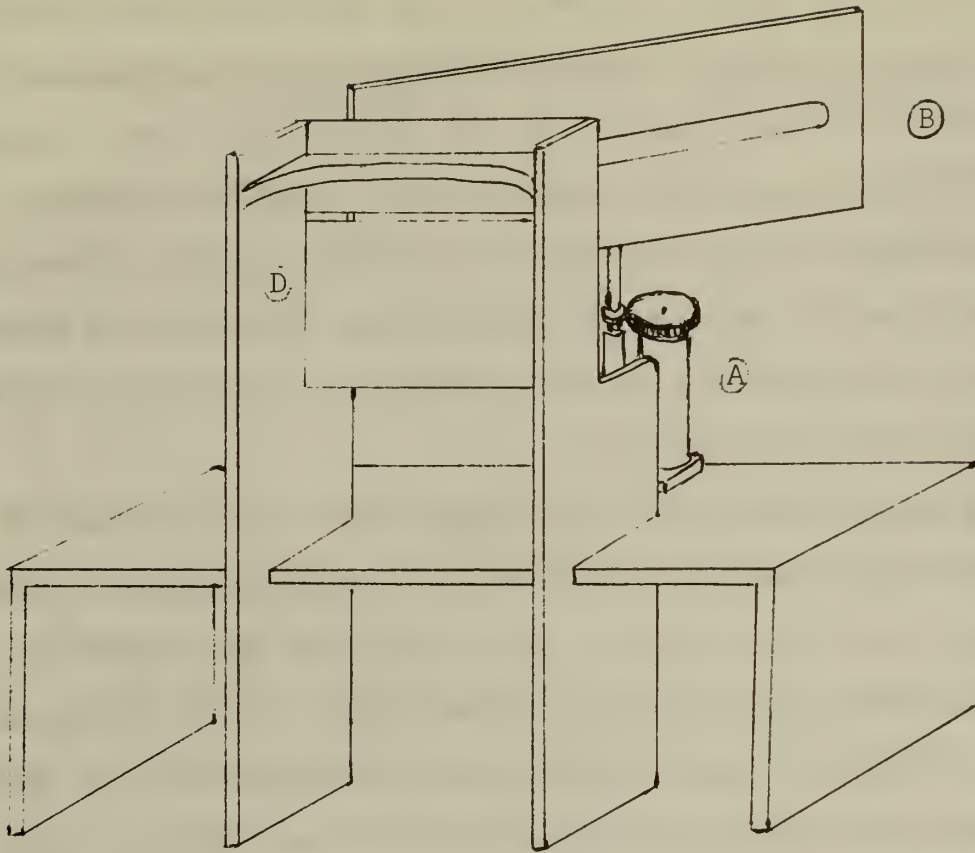

Fig. 3.1 Sketch of Apparatus

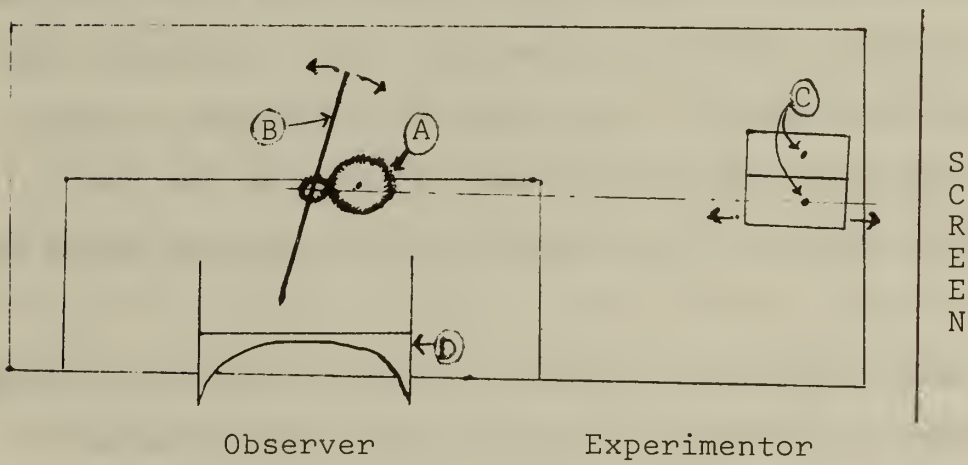

Fig 3.2 Plan View of Experimental Layout

Fig 3.2. This allowed the viewer about 65 degrees of lateral stereo viewing when the full 12 inches of the mirror was available.

It was hoped to completely duplicate the parameters of the Luria-Weissman experiment, a constant .61 seconds target exposure, two rods 3 degrees apart each subtending .1 degree, and the same range of angular velocities. The limitations of the device's field of view reduced the highest angular velocity to 106 degrees per second consonant with the exposure time. Clip-on shields were used to mask off the mirror for a constant viewing time at slower velocities. The other apparent target speeds, 49, 73, and 93 degrees per second, were chosen because they corresponded to easily read voltages on the power supply.

The rods were seen against a white screen, the room fluorescent lighting giving a retinal illumination of 16 foot-candles. The rods were attached to two blocks, both resting on a movable platform. One of the blocks was fixed, the other movable. By means of a scale graduated in eighths of an inch on one of the blocks and a pointer on the other various positions of the rods were presented to the observer.

The observer picked up the images almost directly in front and tracked them to the right or left. Prior to the rods coming into view, the observer could see only a black backdrop draping three sides of the booth, and the white

screen. His vertical viewing angle varied depending on the mirror position but he could not see the tops or bases of the rods.

A random sample of 30 military officer graduate students in the Operations Analysis curriculum at the Naval Postgraduate School were subjects. All were between 23 and 37 years of age with visual acuity corrected to 20-20 or better. The subjects included Army, Marine Corps and Navy Officers, both pilots and non-pilots. Twenty-four subjects showed greater than .1 degree phoria, of these 7 had greater than 1 degree of phoria. Twelve were exophoric, 12 were esophoric and the remaining 6 were termed orthophoric.

Each subject was first given a test for phoria at 46 inches. He was then seated at the apparatus while the following instructions were read:

"This is an experiment designed to test your dynamic stereoscopic vision, in other words, how well you can see things as they move past you. The experiment uses a rotating mirror in which the images of two black rods appear to move past you at different rates. You will look through this slot in the head rest and each time the rods appear tell me whether you think the right rod is nearer to or farther from you than the left rod. You cannot say they are equal.

"There will be four series of presentations with the rods appearing to move from right to left and four from left to right. Your static acuity will also be tested. The

experiment will take about one hour and you may rest whenever you like."

The experimenter's position was alongside of the observer, but hidden by the apparatus (Fig 3.2). Each treatment, static and the eight dynamic series, involved 20 to 30 presentations of the rods. The method of limits was used to locate the approximate threshold (Dember, p.36). Then the threshold was confirmed by a random series of presentations above and below the presumed threshold. The experiment began with a static acuity test, the images of the rods centered in the mirror and exposed manually for about one second.

Next, the dynamic part of the experiment began with the images of the rods rotating in one direction at the slowest speed, continuing in ascending sequence to the highest speed. The apparatus was then reversed along with the direction of image rotation to maintain the same sequence of events for the viewer, i.e. black backdrop, white screen, rods. If this hadn't been done the observer would have looked into his own eyes just prior to seeing the rods. The experiment was continued at the highest speed descending to the lowest. The subject was allowed to rest after the data for each threshold was taken. From the data for each speed and the direction of rotation the mean error, or threshold, and the standard deviation were determined, Tables I and II, Appendix A.

Several problems arise when adapting an apparatus designed for monocular visual acuity tests to one used for

testing depth perception. At low angular velocities the width of the mirror exposed to maintain a constant viewing time is so small that the eye does not view the target binocularly. In the present configuration this limit of binocular viewing occurred below 30 degrees per second. This lack of stereo viewing for the full exposure of the target is not noticeable above about 60 degrees per second where the effect is probably about the same as that of the Luria-Weissman apparatus.

There is a slight parallax shift of the rod images during rotation, from widest separation at the center of the field of view to a slightly smaller lateral angular separation at either side of the image travel. This possible factor was not mentioned to the subjects and was not noted by them, indeed could not be noted by the experimenter. Of course, some subconscious depth cue may have been gained from this and would have been more noticeable at higher velocities.

IV. DATA ANALYSIS

A subject may either show the same positive or negative depth estimation error or reverse this error when the direction of target rotation is reversed. In addition, the direction of error may be consistently associated with the type of lateral phoria. With these ideas in mind the data will be analyzed.

Using simple classificatory methods on the data of Table I, Appendix A, 18 subjects had both positive and negative thresholds in one or both directions of rotation, 4 subjects reversed the direction of error with the direction of rotation, and 8 subjects maintained a constant positive or negative error across all dynamic modes. None of these groups showed any correspondence with the type of phoria.

Table 4.1
Relationship of Subjects with Strong Phoria
to Constant Error

	Esophoria	Exphoria
Constant Positive Error	2	0
Constant Negative Error	0	0
Crossover	2	1
Mixed	1	3

Table 4.1 shows the relationship of the nine subjects with greater than 1 degree of phoria and their direction of error, "cross-over" means direction of error reverses with

target rotation reversed and "mixed" means no consistent pattern of error. Here again there does not seem to be any relationship between phoria and positive or negative thresholds.

Figure 4.1, a graph of the localization error thresholds and the standard deviations, shows a reversal of error about the mean static depth perception threshold. There were no statistically significant differences between the means of the thresholds of corresponding velocities at the .01 level of significance except at 93° per second. This is to be expected if there is no difference in the experimental procedure between the target going from right to left and the target going from left to right. The discrepancy at 93° cannot be explained.

A two-way analysis of variance for the mean thresholds showed no significant differences between the various speeds of rotation, but, as expected, significant differences between the subjects (Table III, Appendix A). A Duncan's Range Test (Hicks, 1963, p. 31) gave no significant groupings within the subjects. There also were no significant effects obtained when the data was analyzed by contrasting the directions of rotation with the various speeds of rotation (Table IV, Appendix A), assuming the fixed-effects model (Ostle, 1969, p. 321).

There was no obvious way to classify the subjects into two groups as Luria and Weissman (1968) were able to do. However, the data may be divided into two groups by summing the error for each direction at a particular velocity.

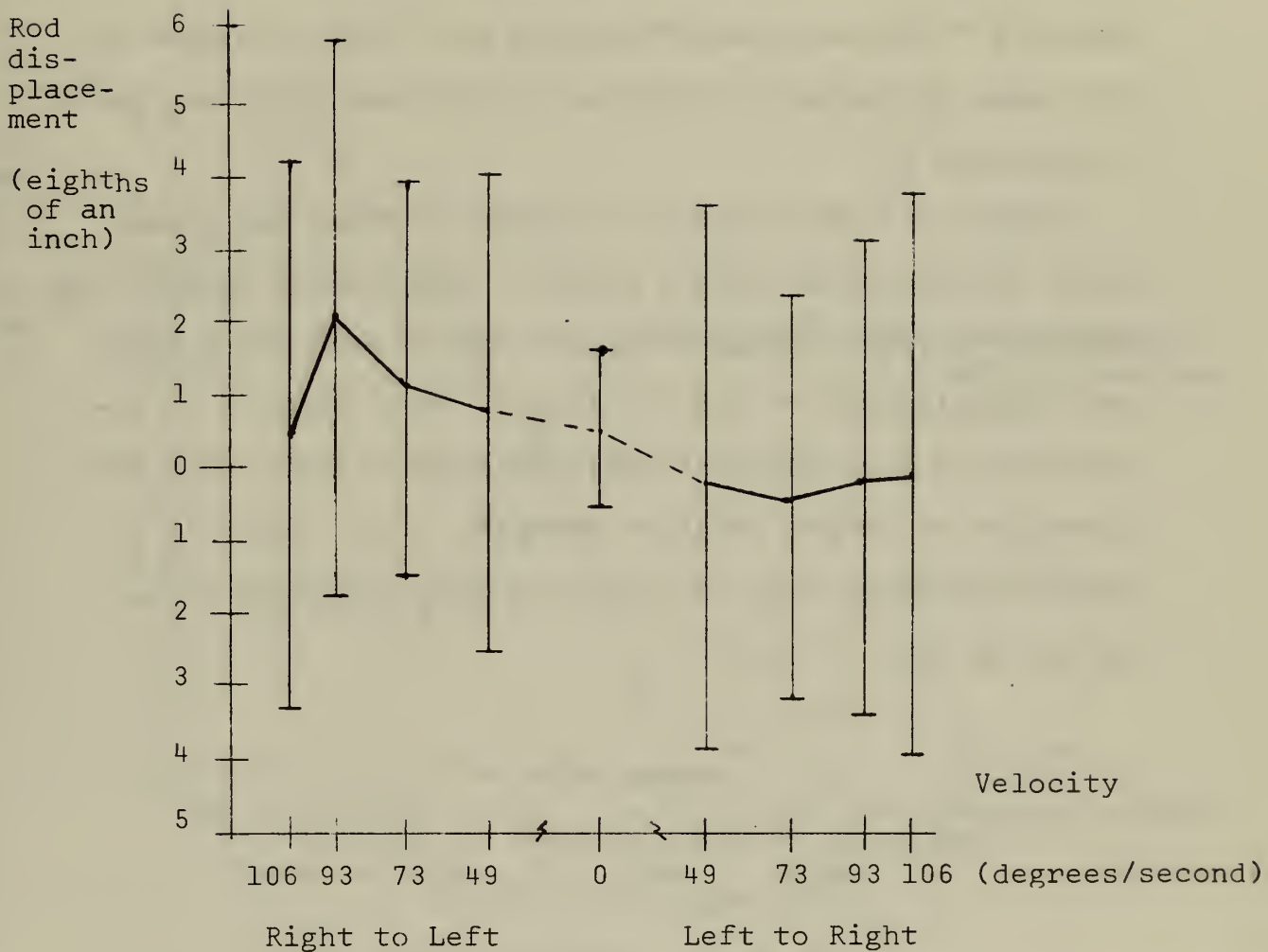

Fig 4.1 Mean depth estimation thresholds and mean standard deviations as a function of target speed and direction, for 30 subjects.

If all four sums for each subject are greater than or equal to zero, the subject is classed as an overestimator; if less than or equal to zero, the subject is classed as an underestimator. By this method, 14 were classified as overestimators and 12 were classed as underestimators. There were actually 7 dubious classifications but 3 were assigned on the basis of having 3 responses of the same sign (see Table I, Appendix A).

Figure 4.2 shows the mean errors of these two groups which should and do have a spread. Differences between the means of corresponding velocities within each group again are insignificant at the .01 level. Thus there is no indication of a reversal of depth estimation error when the direction of target rotation changes. Also, there is no relation between type of lateral phoria and these groups as can be seen in Table 4.2.

Table 4.2

Twenty-six Subjects Grouped by Direction of Error and Lateral Phoria

	Esophoric	Exophoric	Orthophoric
Overestimator	5	6	3
Underestimator	6	5	1

Despite the lack of relation between phoria and depth estimation error found above it might be that a comparison of the subjects by type of phoria with their mean thresholds

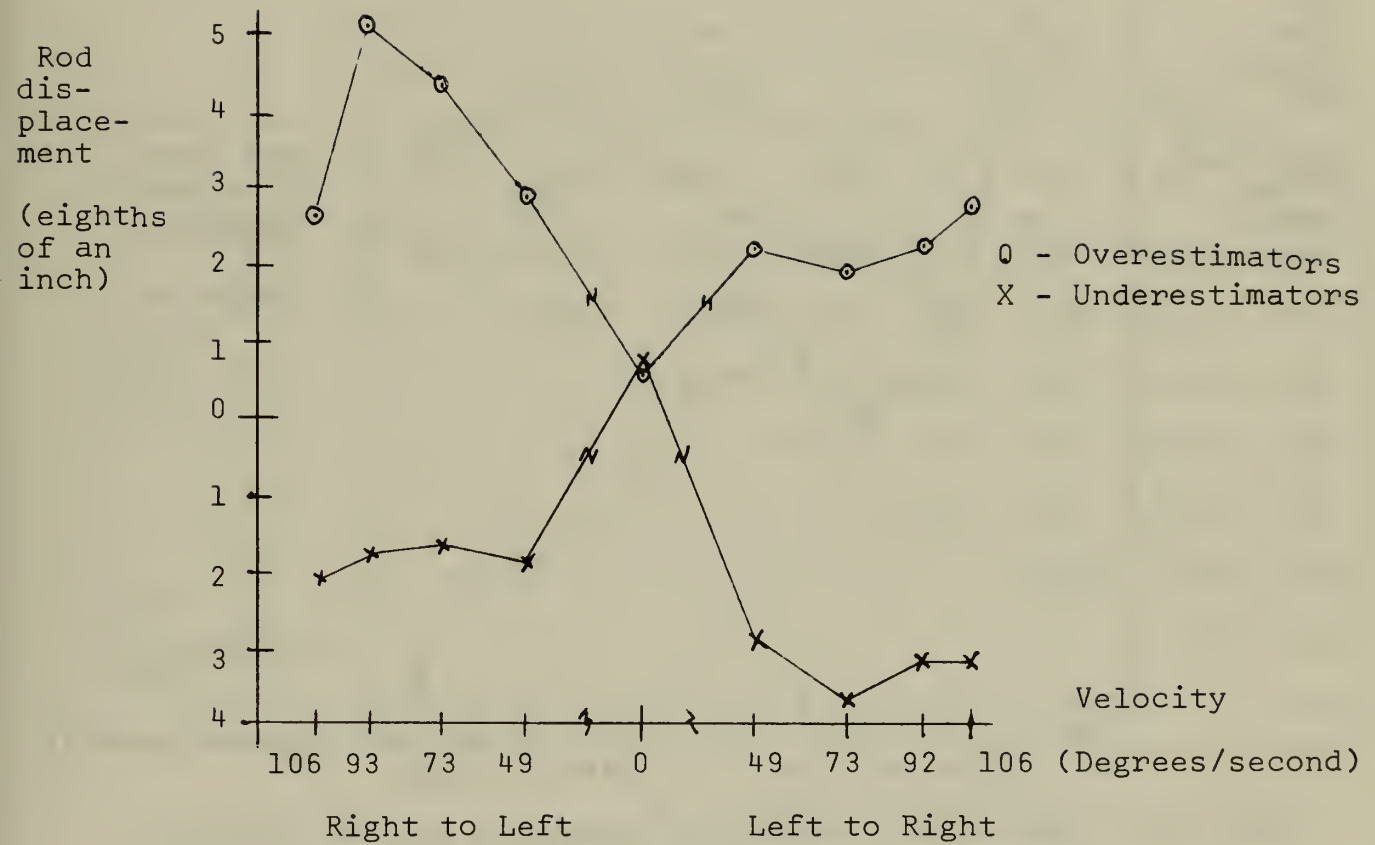

Fig. 4.2 Mean depth estimation thresholds for 26 subjects, grouped by type of error, as a function of target speed and direction

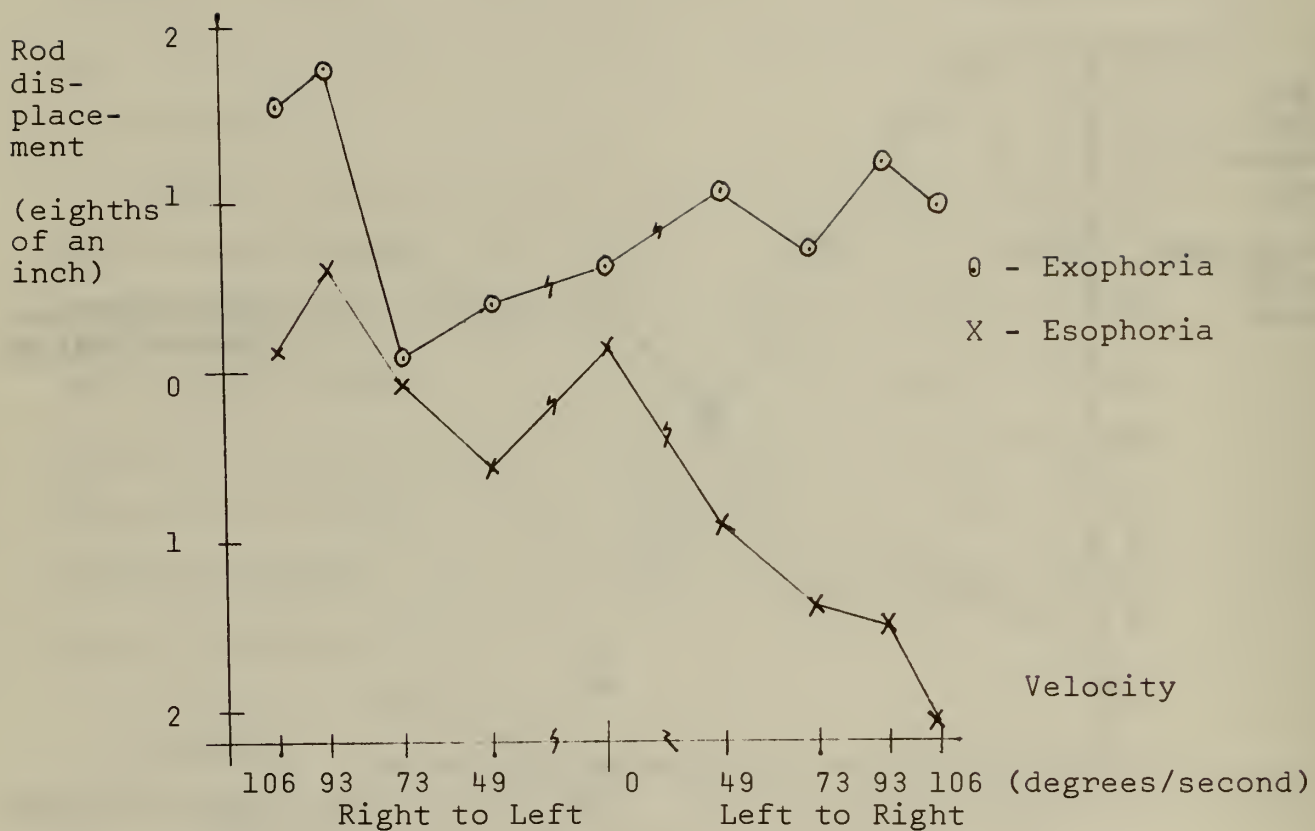

Fig. 4.3. Mean depth estimation thresholds for 30 subjects, grouped by lateral phoria, as a function of target speed and direction.

Table 4.3

Matrix of Correlations of Thresholds

Target Motion (deg/sec)	Right to Left				Left to Right			
	49°	73°	93°	106°	49°	73°	93°	106°
0°	-.085	-.048	-.156	.130	-.171	.044	.120	.064
Right to Left		.743*	.618*	.214	.035	.180	.211	.353
49°			.908*	.328	-.014	-.003	.007	.190
73°				.456	.112	.107	.065	.199
93°					.281	.331	.252	.144
106°								
Left to Right						.859*	.789*	.566*
49°							.932*	.754*
73°								.795*
93°								

*indicates significant at .01 level

Table 4.4.

Matrix of Correlations of Standard Deviations

Target Motion (deg/sec)	Right to Left				Left to Right			
	49°	73°	93°	106°	49°	73°	93°	106°
0°	-.015	-.362	-.106	-.299	.151	.282	.025	.036
49°		.338	.183	.073	.503*	.193	.366	-.074
Right to Left 73°			.624*	.632*	.294	-.024	.307	.190
93°				.432	.331	.163	.173	.375
106°					.306	.165	.224	.330
49°						.413	.241	.200
Left to Right 73°							.483*	.116
93°								.137

*indicates significant at .01 level

would present a picture similar to that of Figure 4.2 thus offering some confirmation of Luria and Weissman's results. Figure 4.3 shows that the data do not appear so neatly well-defined and, indeed, there is no significant difference between the esophoric and exophoric subjects for the data in the right to left direction, but there is a difference between the mean thresholds for the left to right direction.

The hypothesis of no correlation between static and dynamic depth perception was not rejected by the data. Correlations of the thresholds, Table 4.3, show insignificant relationships between dynamic and static acuity and between corresponding velocities. Highly significant relationships are found between all dynamic modes for the left to right presentations and all except the highest velocity for the right to left presentations. The correlations decrease as the velocity increases. The correlation coefficients for the standard deviations show mixed results, Table 4.4, concurring with Table 2.5.

V. CONCLUSIONS

From the discussions in the first two chapters it is apparent that the reason for the discrepancy between dynamic visual acuity and static visual acuity is not just a lack of eye movement capability. The target tracking process must interfere with the normal target scanning process so that image boundaries are not well-defined in the retina, thus a loss of visual acuity occurs. Since the preceding experiment and discussions were restricted to depth perception tasks in which the only depth clue was apparent size, the explanation for the loss of visual acuity may apply equally well to the loss of dynamic depth perception.

Other researchers have shown the effect of motion on depth perception, the existence of a dichotomous response in depth perception error, and the relation of this response to lateral phoria. Since lateral phoria is a quality of the eyes being "out of lateral track," the depth perception error might be direction oriented, that is an observer's responses would reverse on reversal of target motion. However, the experimental evidence points fairly conclusively to dynamic depth estimation error being an effect of target motion but not dependent upon a particular direction of that motion. Further, the association of lateral phoria with a particular direction of depth perception error is not clear, Fig. 4.3. Figure 4.3 is

certainly not as well-defined as Fig. 4.2 (representing the grouping by average error). Such definition would seem to be necessary if lateral phoria accounted for the direction of depth estimation error. Thus, there does not appear to be any readily identifiable group of over or under depth estimators, as was found by Luria and Weissman, which can be related to phoria.

The controversy about the correlation between dynamic and static depth and visual acuity shows that depth perception and visual acuity are very sensitive to motion and also that measures of acuity differ greatly on different tests. The experiment conducted in this paper confirmed the low correlation between static and dynamic depth perception (and indirectly static and dynamic visual acuity) for the range of the experiment.

The correlations between the thresholds, Table 4.3, the graph of the threshold means for all subjects, Fig. 4.1, and for various groupings, Fig. 4.2 and 4.3, all indicate that there may have been some unknown factor entering into the experiment at the highest velocity going from right to left. However, the analyses of variance conclusively show that there are no significant differences between the directions of rotation.

The experiment conducted by the author used the secondary cue of apparent size. Several other depth perception cues might be investigated when the target is moving to see if the loss of stereo acuity is the same as

that for apparent size. If two rods at unequal distances from the observer were moved laterally through a field of stationary rods, the secondary cue of superposition could be tested. The primary cues of accommodation and convergence could be tested if two rods were alternately appearing as they moved through the field of view.

Since the direction of dynamic depth estimation error does not seem to be identifiable with lateral phoria some other association may be sought. It should be emphasized that even a relation between phoria and the dichotomous responses did not offer a mechanism, merely an association. The depth error may be related to the method of tracking. In this case the normal scanning movements necessary to move the image around on the retina might be interrupted by the tracking process causing a reduction in image intensity or an extra-foveal position for the image. The explanation for under or over-estimating the distance would then lie in the brain's interpretation of the nerve impulses. Or, the error may be something quite simple such as the center of target rotation not coinciding exactly with the midpoint between the eyes. It is hoped that the lack of directional bias in dynamic depth perception error can be confirmed on apparatus with a wider range of target velocities.

Ellingstad and Heimstra found a similar type of dichotomous response in their experiment relating to dynamic vision. This may indicate that the primary factor producing

different responses in subjects is either the time sense or tracking ability rather than any particular quality of depth. However, the whole problem may be one of trying to see more in the data than is present. Almost any division of a set of data into two groups by the criterion of their responses being above or below the overall mean will produce a graph showing two separate lines, and thus a dichotomy.

It does seem clear that a subject exhibits relatively consistent responses when estimating the depth of a moving object regardless of the direction of motion. His responses are poorly correlated with his static depth perception ability and not at all with his lateral phoria. The subjects may be classed into two groups of under estimators and over estimators, again showing no correlation with type of phoria. But the significance of these groups or the relation of the subjects' response to any visual mechanism is not clear.

Appendix A
Data and Analyses of Variance

Table I
Depth Perception Threshold Data
Direction of Motion

Sub- ject	Static		Right to Left			Left to Right				Phoric Type	Type Est.
	0°	49°	73°	93°	106°	49°	73°	93°	106°		
1	0.0	0.0	-1.5	0.5	-1.0	13.5	11.5	11.5	8.5	X*	+
2	-1.0	0.5	-4.0	1.5	-4.5	4.0	4.0	4.5	8.5	X	+
3	0.0	1.0	1.5	1.0	0.0	-1.5	-1.5	-2.5	-1.5	S*	-
4	-1.0	6.5	2.5	-1.0	-2.5	1.0	1.5	1.5	7.0	O	+
5	-0.5	1.0	0.0	0.5	-2.0	0.0	0.0	0.5	0.0	O	?
6	-1.5	-1.0	-1.0	1.0	3.5	4.5	3.5	1.0	-1.0	S	+
7	0.0	-1.5	-1.5	-4.0	2.5	1.0	1.0	0.5	3.5	X	-
8	10.0	-3.0	-2.0	-5.5	-4.5	-7.0	-3.0	-2.5	-1.5	O	-
9	3.5	-0.5	3.5	1.5	1.0	-0.5	2.5	3.5	5.0	S*	+
10	-0.5	1.0	-1.5	-8.5	-8.0	-8.0	-10.0	-6.0	-8.5	S	-
11	-0.5	-4.0	-4.5	-3.0	0.0	0.5	0.0	0.0	0.0	S	-
12	-0.5	-5.0	-4.5	-2.0	1.0	1.5	-5.0	-5.0	-8.5	X*	-
13	0.5	2.5	1.0	1.5	-1.5	-7.5	-3.0	-1.0	-2.5	X*	-
14	0.5	1.5	1.5	2.5	0.5	1.0	1.0	2.0	1.5	O	+
15	-1.5	-2.0	-1.0	-2.0	-10.0	1.0	-2.0	-0.5	-1.0	X	-
16	-0.5	3.5	5.0	5.5	3.0	-2.0	-1.0	-1.5	-2.0	S*	+
17	0.5	-0.5	3.0	3.5	2.5	1.0	-1.0	-2.0	1.5	X	+
18	-1.0	11.5	34.5	34.5	4.5	-1.0	-2.5	-2.0	2.0	O	+
19	2.0	8.0	2.5	2.5	2.0	-2.5	0.5	2.5	2.5	X	+
20	3.0	1.5	5.0	7.0	20.0	2.5	3.0	3.5	2.0	X	+
21	2.0	-5.0	-4.0	-2.0	-2.0	0.0	-3.5	-4.0	-4.5	S	-
22	-1.5	-9.0	-6.5	-2.0	-4.5	-9.0	-10.0	-9.0	-5.0	S	-
23	-0.5	2.0	1.5	3.0	2.0	-3.5	-3.5	-4.5	-4.0	S	-
24	0.0	-2.0	-4.0	0.5	0.5	3.0	4.0	1.5	-5.0	S	?
25	0.0	5.5	0.5	2.0	-3.0	-3.0	-0.5	-1.0	2.0	O	?
26	0.0	7.5	7.5	7.5	2.5	0.5	-1.5	-3.5	-2.5	S*	+
27	1.0	1.0	2.5	2.5	0.5	-3.0	-4.0	-3.0	-4.5	X*	-
28	0.0	-2.5	-3.5	6.5	5.5	-0.5	0.0	-0.5	-1.5	X	?
29	2.5	2.5	2.0	3.5	1.5	3.5	1.0	4.0	2.5	X	+
30	1.5	0.5	1.0	2.5	3.5	5.0	3.5	6.5	3.0	S	+

(Data in eighths of an inch) S= Esophoric + = Overestimator
 X= Exophoric - = Underestimator
 O= Orthophoric * = greater than
 1° phoria

Table II

STANDARD DEVIATION OF THRESHOLDS

Direction of Motion

Sub- ject	Static	Right to Left				Left to Right			
	0°	49°	73°	93°	106°	49°	73°	93°	106°
1	5.0	2.0	1.5	2.5	1.0	3.5	3.5	3.5	1.5
2	3.0	4.5	0.0	5.5	0.5	4.0	3.0	0.5	2.5
3	1.0	2.0	1.5	4.0	5.0	3.5	4.5	3.5	1.5
4	0.0	4.5	2.5	2.0	2.5	1.0	0.5	3.5	2.0
5	0.5	3.0	3.0	2.5	3.0	3.0	1.0	1.5	3.0
6	0.5	4.0	4.0	4.0	3.5	5.5	3.5	4.0	6.0
7	1.0	5.5	1.5	1.0	2.5	2.0	4.0	6.5	2.5
8	3.0	3.0	2.0	3.5	4.5	4.0	3.0	3.5	4.5
9	1.5	6.5	2.5	3.5	3.0	7.5	3.5	4.5	5.0
10	0.5	0.5	2.5	4.5	5.0	2.0	2.0	5.0	3.5
11	0.5	2.0	2.5	1.0	2.0	1.5	0.0	1.0	1.0
12	2.5	2.0	2.5	5.0	2.0	3.5	5.0	5.0	7.5
13	4.5	3.5	1.0	4.5	4.5	6.5	2.0	3.0	6.5
14	0.5	0.5	1.5	2.5	2.5	0.0	1.0	1.0	1.5
15	2.5	3.0	2.0	5.0	2.0	3.0	4.0	4.5	3.0
16	1.5	1.5	4.0	3.5	7.0	4.0	3.0	3.5	6.0
17	0.5	2.5	1.0	1.5	1.5	2.0	1.0	1.0	2.5
18	0.0	5.5	9.5	15.0	7.5	6.5	2.5	4.0	5.0
19	0.0	4.0	3.5	3.5	4.0	7.5	1.5	3.5	3.5
20	0.0	1.5	2.0	6.0	4.0	3.5	4.0	2.5	3.0
21	0.0	3.0	3.0	3.0	4.0	1.0	2.5	3.0	4.5
22	1.5	5.0	4.5	3.0	4.5	5.0	4.0	6.0	2.0
23	0.5	2.0	2.5	2.0	4.0	3.5	2.5	3.5	5.0
24	1.0	2.0	2.0	4.5	5.5	5.0	4.0	1.5	10.0
25	1.0	3.5	2.5	2.0	3.0	8.0	3.5	3.0	2.0
26	0.0	6.5	3.5	5.0	6.5	6.5	4.5	4.5	2.5
27	0.0	4.0	2.5	3.5	3.5	4.0	3.0	3.0	1.5
28	0.0	3.5	3.5	7.5	3.5	2.5	1.0	4.5	9.5
29	0.5	1.5	3.0	2.5	5.5	1.5	2.0	2.0	4.5
30	2.5	5.5	4.0	1.5	4.5	3.0	2.5	2.5	3.0

TABLE III

Analysis of Variance Contrasting Subjects
with the Static and all Dynamic Target Velocities

SOURCE OF VARIATION	DEGREES OF FREEDOM	SUMS OF SQUARES	MEAN SQUARE	F - RATIO
Velocities	8	155.07	19.384	1.107
Subjects	29	2378.61	82.021	4.682
Error	232	4063.89	17.517	
Total	269	6597.57		

TABLE IV

Analysis of Variance Contrasting Dynamic Target
Velocities with direction of rotation

SOURCE OF VARIATION	DEGREES OF FREEDOM	SUMS OF SQUARES	MEAN SQUARE	F - RATIO
Velocities	3	23.09	7.7	0.28
Directions	1	114.13	114.13	4.18
V X D	3	23.44	7.81	0.29
Error	232	6327.79	27.28	
Total	239	6488.45		

LIST OF REFERENCES

- Alpern, M., Lawrence, M., and Wolsk, D., Sensory Processes, Brooks/Cole Publishing Company, Belmont, California 1967.
- Burg, A., and Hurlbert, S., "Dynamic Visual Acuity as Related to Age, Sex, and Static Acuity," Journal of Applied Psychology, v. 45, No. 2, p. 111-116, 1961.
- Burg, A., "Apparatus for Measurement of Dynamic Visual Acuity," Perceptual and Motor Skills, v. 20, p. 231-234, 1965.
- Burg, A., "Visual Acuity as Measured by Dynamic and Static Tests," Journal of Applied Psychology, v. 50, No. 6, p. 460-466, 1966.
- Dember, W.N., The Psychology of Perception, Holt, Rinehart and Winston, New York, 1963.
- Ellingstad, V.S., and Heimstra, N.W., "Velocity-Time Estimation as a Function of Target Speed and Concealment Extent," Human Factors, v. 11, No. 4, p. 305-312, 1969.
- Geldard, F.A., The Human Senses, Wiley, New York, 1963.
- Hicks, C.R., Fundamental Concepts in the Design of Experiments, Holt, Rinehart and Winston, New York, 1963.
- Holzman, P.S., and Klein, G.S., "Cognitive System-Principles of Leveling and Sharpening," Journal of Psychology, v. 37, p. 105-122, 1954.
- Lit, A., "The Magnitude of the Pulfrich Stereophenomenon as a Function of Binocular Differences of Intensity at Various Levels of Illumination," The American Journal of Psychology, v. 62, No. 2, p. 159-181, 1949.
- Lit, A., "Magnitude of the Pulfrich Stereophenomenon as a Function of Target Thickness," Journal of the Optical Society of America, v. 50, No. 4, p. 321-327, 1960.
- Lit, A., "Effect of Target Velocity on a Frontal Plane on Binocular Spatial Localization at Photopic Retinal Illuminance Levels," Journal of the Optical Society of America, v. 50, No. 10, p. 970-973, 1960.

- Lit, A., "Equidistance Settings at Photopic Retinal-Illuminance Levels as a Function of Target Velocity in a Frontal Plane," Journal of the Optical Society of America, v. 54, No. 1, p. 83-88, 1964.
- Lit, A., and Hamm, H.D., "Depth-Discrimination Thresholds for Stationary and Oscillating Targets at Various Levels of Retinal Illuminance," v. 56, No. 4, p. 510-516, 1966.
- Ludvigh, E., and Miller, J.W., "Study of Visual Acuity during the Ocular Pursuit of Moving Test Objects, I. Introduction," Journal of the Optical Society of America, v. 48, No. 11, p. 799-802, 1958.
- Luria, S.M., and Weissman, S., "Relationship between Static and Dynamic Acuity," Journal of Experimental Psychology, v. 76, No. 1, p. 51-56, 1968.
- Miller, J.W., "Study of Visual Acuity during the Ocular Pursuit of Moving Test Objects, II. Effects of Direction of Movement, Relative Movement, and Illumination," Journal of the Optical Society of America, v. 48, No. 11, p. 803-808, 1958.
- Ogle, K.N., "The Visual Space Sense," Science, v. 135, No. 3506, p. 763-771, 1962.
- Ostle, B., Statistics in Research, 2nd ed., The Iowa State University Press, Ames Iowa, 1969.
- Rawlings, S.C., and Shipley, T., "Stereoscopic Acuity and Horizontal Angular Distance from Fixation," Journal of the Optical Society of America, v. 69, No. 5, p. 991-993, 1969.
- Weissman, S., and Freeburne, C.M., "Relationship between Static and Dynamic Visual Acuity," Journal of Experimental Psychology, v. 70, No. 2, p. 141-146, 1965.

INITIAL DISTRIBUTION LIST

	No. Copies
1. Defense Documentation Center Cameron Station Alexandria, Virginia 22314	20
2. Library, Code 0212 Naval Postgraduate School Monterey, California 93940	2
3. Department of Operations Analysis, Code 55 Naval Postgraduate School Monterey, California 93940	1
4. Asst Professor G.K. Poock, Code 55 Department of Operations Analysis Naval Postgraduate School Monterey, California 93940	1
5. Commandant of the Marine Corps (Code A03C) Headquarters, U.S. Marine Corps Washington, D.C. 20380	1
6. James Carson Breckinridge Library Marine Corps Development and Educational Command Quantico, Virginia 22134	1
7. Major L.A. Rolstad, USMC 3562 Oliver Rd. Carmel, California 93921	1
8. Commandant of the Marine Corps (Code AX) Headquarters, U.S. Marine Corps Washington, D. C. 20380	1

DOCUMENT CONTROL DATA - R & D

(Security classification of title, body of abstract and indexing annotation must be entered when the overall report is classified)

1. ORIGINATING ACTIVITY (Corporate author) Naval Postgraduate School Monterey, California 93940	2a. REPORT SECURITY CLASSIFICATION Unclassified
	2b. GROUP

3. REPORT TITLE
Dynamic Depth Perception

4. DESCRIPTIVE NOTES (Type of report and, inclusive dates)
Master's Thesis; (April 1970)

5. AUTHOR(S) (First name, middle initial, last name)
Lawrence Arian Rolstad

6. REPORT DATE April 1970	7a. TOTAL NO. OF PAGES 47	7b. NO. OF REFS 21
------------------------------	------------------------------	-----------------------

8a. CONTRACT OR GRANT NO. b. PROJECT NO. c. d.	9a. ORIGINATOR'S REPORT NUMBER(S)
	9b. OTHER REPORT NO(S) (Any other numbers that may be assigned this report)

10. DISTRIBUTION STATEMENT
This document has been approved for public release and sale; its distribution is unlimited.

11. SUPPLEMENTARY NOTES	12. SPONSORING MILITARY ACTIVITY Naval Postgraduate School Monterey, California
-------------------------	---

13. ABSTRACT

A review of research in visual acuity and depth perception of moving objects disclosed differing estimates of the relation between dynamic and static vision performance. Additionally, two distinct types of responses appear in distance estimates for moving targets as well as the elapsed time estimates for partially concealed targets. The possible relation of this depth estimation error dichotomy to lateral phoria is discussed. An experiment demonstrates that the depth estimation error dichotomy, if it exists, is not related to phoria and is independent of the direction of target motion. Further evidence of the lack of correlation between dynamic and static depth perception is presented.

14

KEY WORDS

LINK A

LINK B

LINK C

ROLE

WT

ROLE

WT

ROLE

WT

Depth Perception

Visual Acuity

Vision

Lateral Phoria

Motion

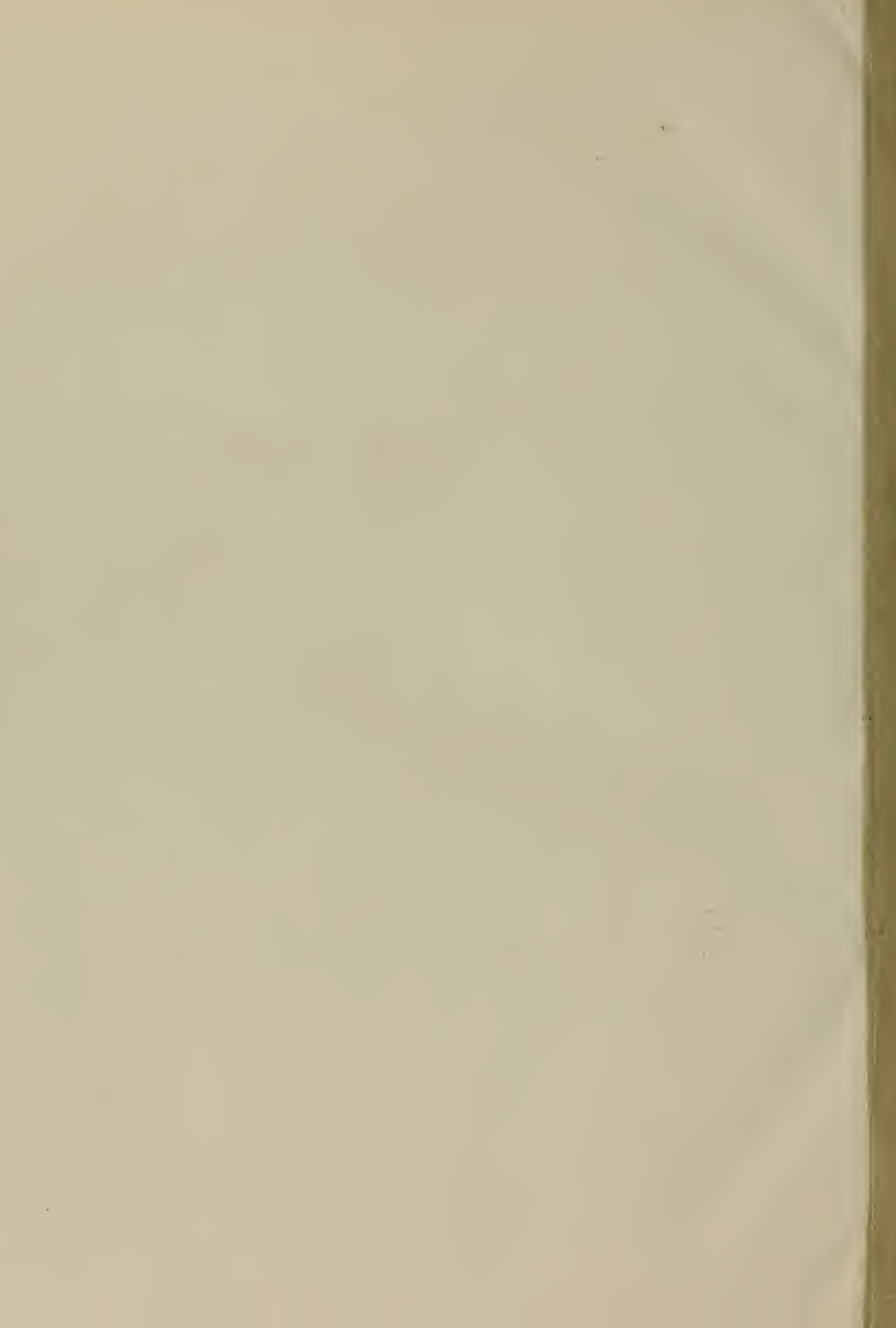

1 NOV 72

20454

Thesis

118280

R68955 Rolstad

c.1 Dynamic depth perception.

1 NOV 72

20454

Thesis

118286

R68955 Rolstad

c.1 Dynamic depth perception.

thesR68955

Dynamic depth perception.

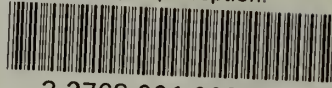

3 2768 001 00289 2

DUDLEY KNOX LIBRARY