



Calhoun: The NPS Institutional Archive
DSpace Repository

Theses and Dissertations

1. Thesis and Dissertation Collection, all items

1986-12

Transonic compressor blade tip flow visualization on a water table

Byrd, Alan K.

<https://hdl.handle.net/10945/22158>

Downloaded from NPS Archive: Calhoun



Calhoun is the Naval Postgraduate School's public access digital repository for research materials and institutional publications created by the NPS community. Calhoun is named for Professor of Mathematics Guy K. Calhoun, NPS's first appointed -- and published -- scholarly author.

Dudley Knox Library / Naval Postgraduate School
411 Dyer Road / 1 University Circle
Monterey, California USA 93943

<http://www.nps.edu/library>



DUDLEY A. BROWN LIBRARY
NAVAL POSTGRADUATE SCHOOL
MONTEREY, CALIFORNIA 93943-5002

NAVAL POSTGRADUATE SCHOOL

Monterey, California

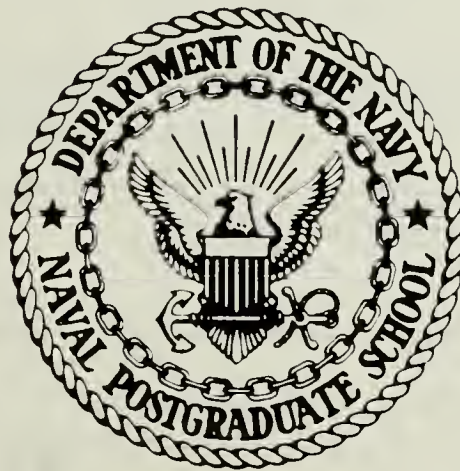

THESIS

TRANSONIC COMPRESSOR BLADE TIP FLOW
VISUALIZATION ON A WATER TABLE

by

Alan K. Byrd

December 1986

Thesis Advisor:

Raymond P. Shreeve

Approved for public release; distribution is unlimited

T230152

THE UNIVERSITY OF CHICAGO



PHILOSOPHY



5210EST

REPORT DOCUMENTATION PAGE

1a REPORT SECURITY CLASSIFICATION Unclassified		1b RESTRICTIVE MARKINGS	
2a SECURITY CLASSIFICATION AUTHORITY		3 DISTRIBUTION/AVAILABILITY OF REPORT Approved for public release; distribution is unlimited	
2b DECLASSIFICATION/DOWNGRADING SCHEDULE		5 MONITORING ORGANIZATION REPORT NUMBER(S)	
4 PERFORMING ORGANIZATION REPORT NUMBER(S)		7a NAME OF MONITORING ORGANIZATION Naval Postgraduate School	
5a NAME OF PERFORMING ORGANIZATION Naval Postgraduate School	6b OFFICE SYMBOL (if applicable) Code 67	7b ADDRESS (City, State, and ZIP Code) Monterey, California 93940-5000	
8c ADDRESS (City, State, and ZIP Code) Monterey, California 93940-5000		9 PROCUREMENT INSTRUMENT IDENTIFICATION NUMBER	
1a NAME OF FUNDING/SPONSORING ORGANIZATION	8b OFFICE SYMBOL (if applicable)	10 SOURCE OF FUNDING NUMBERS	
8c ADDRESS (City, State, and ZIP Code)		PROGRAM ELEMENT NO	PROJECT NO
		TASK NO	WORK UNIT ACCESSION NO
1 TITLE (Include Security Classification) TRANSONIC COMPRESSOR BLADE TIP FLOW VISUALIZATION ON A WATER TABLE			
2 PERSONAL AUTHOR(S) Byrd, Alan K.			
3a TYPE OF REPORT Masters Thesis	13b TIME COVERED FROM _____ TO _____	14 DATE OF REPORT (Year, Month, Day) 1986, December	15 PAGE COUNT 58
6 SUPPLEMENTARY NOTATION			
7 COSATI CODES		18 SUBJECT TERMS (Continue on reverse if necessary and identify by block number)	
FIELD	GROUP	Transonic Compressor Cascade Flow Visualization	
9 ABSTRACT (Continue on reverse if necessary and identify by block number)			
<p>The shock structure at the tip of a transonic compressor rotor was investigated on a water table. A four bladed cascade model was used and the wave pattern was examined at variable incidence, flow turning angles and back-pressures. Froude numbers, (equivalent to Mach numbers in the analogous two dimensional gas flow), in the range 1.6 to 1.74 resulted in an oblique shock between the blade passages starting from the leading edge pressure side of the blading. Qualitative agreement of the shock structure with earlier tests using the same blading in a transonic blow-down tunnel was observed, leading to the conclusion that the shock present in the compressor would be oblique and not normal as was previously assumed.</p>			
20 DISTRIBUTION/AVAILABILITY OF ABSTRACT <input type="checkbox"/> UNCLASSIFIED/UNLIMITED <input type="checkbox"/> SAME AS RPT <input type="checkbox"/> DTIC USERS		21 ABSTRACT SECURITY CLASSIFICATION Unclassified	
2a NAME OF RESPONSIBLE INDIVIDUAL Prof. Raymond P. Shreeve		22b TELEPHONE (Include Area Code) (408) 646-2593	22c OFFICE SYMBOL Code 67SI

Approved for Public Release; Distribution is unlimited

Transonic Compressor Blade Tip
Flow Visualization on a
Water Table

by

Alan K. Byrd
Lieutenant, United States Navy
B.S. Clemson University 1979

Submitted in partial fulfillment of the
requirements for the degree of

MASTER OF SCIENCE IN AERONAUTICAL ENGINEERING

from the

NAVAL POSTGRADUATE SCHOOL

December 1986

ABSTRACT

The shock structure at the tip of a transonic compressor rotor was investigated on a water table. A four bladed cascade model was used and the wave pattern was examined at variable incidence, flow turning angles and back-pressures. Froude numbers, (equivalent to Mach numbers in the analogous two dimensional gas flow), in the range 1.6 to 1.74 resulted in an oblique shock between the blade passages starting from the leading edge pressure side of the blading. Qualitative agreement of the shock structure with earlier tests using the same blading in a transonic blow-down tunnel was observed, leading to the conclusion that the shock present in the compressor would be oblique and not normal as was previously assumed.

TABLE OF CONTENTS

I.	INTRODUCTION	9
II.	APPARATUS AND INSTRUMENTATION	11
	A. GENERAL DESCRIPTION	11
	B. CASCADE BLADES	11
	C. FLOW TURNING CONTROL	11
	D. BACK PRESSURE CONTROL	16
	E. DEPTH PROBE SURVEY EQUIPMENT	17
	F. SHADOWGRAPH AND DIRECT PHOTOGRAPHY	17
III.	EXPERIMENTAL PROGRAM AND PROCEDURES	21
	A. PRELIMINARY INVESTIGATIONS	21
	1. Achieving proper flow conditions	21
	2. Recording flow structure	21
	B. CONTROLLED VARIATIONS IN FLOW TURNING AND BACKPRESSURE	24
VI.	RESULTS	25
	A. FLOW CHARACTERISTICS	25
	B. QUANTITATIVE ANALYSIS	28
VII.	CONCLUSIONS	30
	APPENDIX A: HYDRAULIC ANALOGY	30
	APPENDIX B: SHADOWGRAPH TECHNIQUE	36
	APPENDIX C: WATER TABLE AND OPERATING PROCEDURES	38
	APPENDIX D: AERO-ENGINEERING WATER TABLE	43
	APPENDIX E: COMPENDIUM OF PHOTOGRAPHIC DATA	47
	LIST OF REFERENCES	55

BIBLIOGRAPHY ----- 56
INITIAL DISTRIBUTION ----- 57

LIST OF TABLES

2.1	COMPRESSOR ROTOR TIP AND CASCADE BLADE DATA -----	16
A.1	HYDRAULIC ANALOGY PARAMETERS -----	32
D.1	COMPARISON OF WATER TABLE TYPES -----	45

LIST OF FIGURES

2.1	Mechanical Engineering Water Table -----	12
2.2	Cascade Blades -----	13
2.3	Cascade Notation -----	14
2.4	Cascade Mounting -----	15
2.5	Outlet Tailboards -----	15
2.6	Throttling Valve -----	18
2.7	Choked Cascade -----	19
2.8	Depth Probe Survey System -----	19
2.9	Shadow Graph Arrangement -----	20
3.1	Representative Shadowgraph Photo -----	23
4.1	Representative Cascade Flow Photographs -----	26
A.1	Pressure Ratio and Depth Ratio vs Mach number -----	31
A.2	Hydraulic Jump Characteristics -----	35
B.1	Shadowgraph Formation -----	37
C.1	Water Table -----	39
C.2	Profile View of Test Section -----	40
C.3	Water Table Drive System -----	40
D.1	Plan View of Novel Water Table -----	46
E.1	Flow Photographs and Test Data -----	48

ACKNOWLEDGEMENT

The work presented here was supported by a very dedicated and professional group of people.

Many thanks to Mr. Don Harvey for his detailed work on the cascade blade supports which he produced on short notice, Mr. Ron Ramaker for his unyielding help and direction on modifications to the water table and for the construction of the depth probe survey system as well as restoring the table to its former configuration. Also a special thanks to Mr. Mike Odell and Mr. Thaddeus "Ted" Best for their untiring efforts in the pursuit of the elusive gremlins in the transonic compressor and for helping to ferry equipment between the school and lab.

Dr. T. Sarpkaya provided the water table and encouragement throughout the experiment. His criticisms and humor were greatly appreciated.

Dr. Raymond P. Shreeve provided the guidance and help in all phases of the project which proved to be both interesting and challenging.

And last but not least comes the NPS photo division for their tireless work in developing all the photographs without which the experiment would not have been a success.

I. INTRODUCTION

The analysis of the shock pattern generated at the tip of a transonic compressor blade has been of interest in the interpretation of unsteady measurements obtained from the case-wall of the machine. The on-going study, at the Naval Postgraduate School Turbo-propulsion Laboratory, aims to understand three-dimensional and unsteady effects in the transonic blade rows. A cascade of blades was built [Ref. 1], scaled from the transonic compressor geometry [Ref. 2], to model the flow at the rotor tip in a transonic blow-down tunnel. It had been assumed in the design of the blading that the shock generated at the tip in the compressor, and hence in the cascade blade passage would be normal. This, however was not observed in the subsequent experiments, [Ref. 3]. Instead, an oblique shock pattern was seen to develop in a limited number of tests which were made. The test program was curtailed by the occurrence of blade failures, resulting from stress concentrations at the support tab and unavailability of the compressed air supply during recertification.

To continue and independently verify the shock structure analysis a water table experiment was developed in the present work to visualize the wave pattern between the blades. A water table located in the Mechanical Engineering Department of the school designed by Dr. T. Sarpkaya was used. Modifications to the water table to produce transonic flow were necessary, as described in the following section.

The hydraulic analogy of shallow water to two-dimensional compressible gas flow (Appendix A) allowed the same blading that was in the transonic blow-down tunnel to be used on the water table. It was only necessary to remove the mounting tabs on one side of the blades. It was desired to model the flow at the same relative Mach number as in the wind tunnel. This was not possible however due to the inability of the the water table and model combined to produce acceptable flow conditions at relative Mach numbers less than

about 1.6. At lower speeds a shock developed in the passages by-passing the model which traveled upstream and unchoked the inlet flow.

At all test conditions which were set the shock pattern developed by progressively increasing back pressures to fully subsonic outlet flow included an oblique leading shock within the blade passage. While at a slightly higher simulated Mach number, this agreed qualitatively with the blow-down cascade, [Ref. 3]. It was therefore possible to conclude that the shock pattern that would be developed in the transonic compressor at design speeds would likely be oblique. While it was found to be difficult to interpret water depths measured in the water table experiments in terms of pressure ratios to be expected in the analogous gas flow, it was also concluded that the analogy was an acceptable, useful, and economical method for qualitative analysis of flow patterns developed in cascade models.

The account presented on the following pages describes the apparatus, procedures, results, and conclusions of the water table study. While direct-light photography was used finally to record the surface wave patterns, initial attempts to use shadowgraph photography were made following the principles which are described in Appendix B. The operating procedures for the water table are given in Appendix C, and suggestions for the design of a water table more suited to the transonic cascade application are given in Appendix D. In order to illustrate the limited changes which occurred qualitatively in the wave structure for significant changes in the test conditions, a compendium of photographs is given without discussion in Appendix E.

II. APPARATUS AND INSTRUMENTATION

A. GENERAL DESCRIPTION

The tests were conducted in a vertical return closed circuit water table. Figure 2.1 shows the flow circuit and plan view of the free surface, test section, sluice gate, drive shaft, and impeller. The test section was horizontal, with circular reservoir flow entrance and exit ramps. The table measured 20 inches in width by 71 inches in length. The water depth for all tests was $7/8$ inches. Appendix C describes the water table and its components in detail.

B. CASCADE BLADING

The cascade blades, which were those designed by Demo [Ref. 1], are shown in Figure 2.2. Figure 2.3 shows the cascade geometry and defines pertinent notation. The cascade was mounted in a Plexiglas window (Fig. 2.4) which provided a transparent jig from which the blades were cantilevered. The assembly was placed on the water table on the free ends of the blades.

The cascade blades were a seven-tenths scale two dimensional model of the tip section of the transonic compressor blades designed by Vavra, [Ref. 2]. Table 2.1 gives the relationship of the transonic compressor rotor tip to the cascade blades used in the water table experiments.

C. FLOW TURNING CONTROL

The turning angle of the flow through the cascade was controlled using tailboards formed from two aluminum angle sections as shown in Figure 2.5. The sections were placed in the water table, weighted down, and attached with modeling clay.

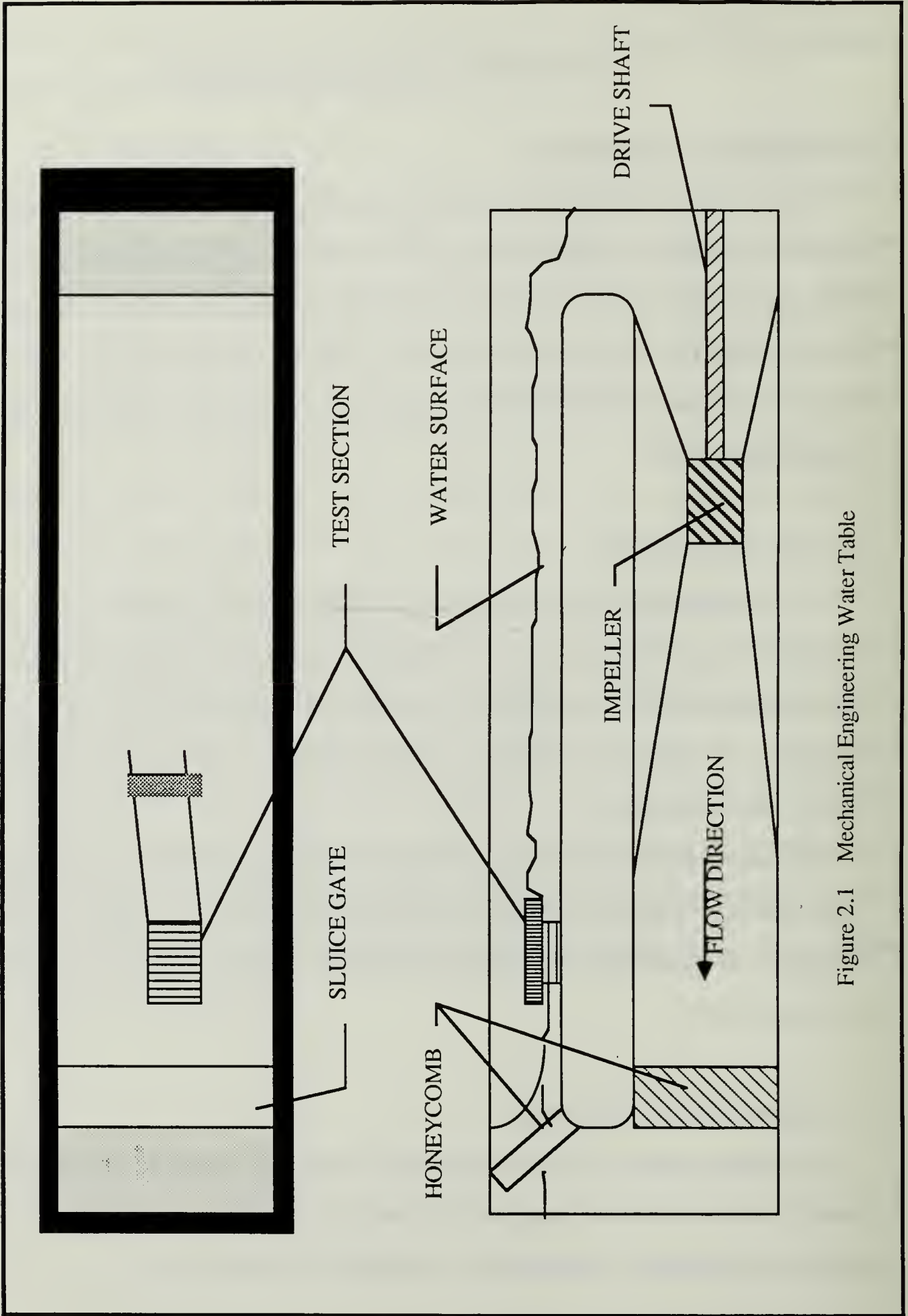
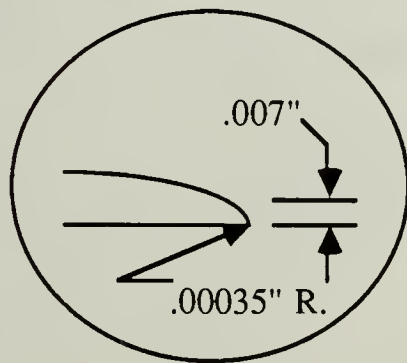
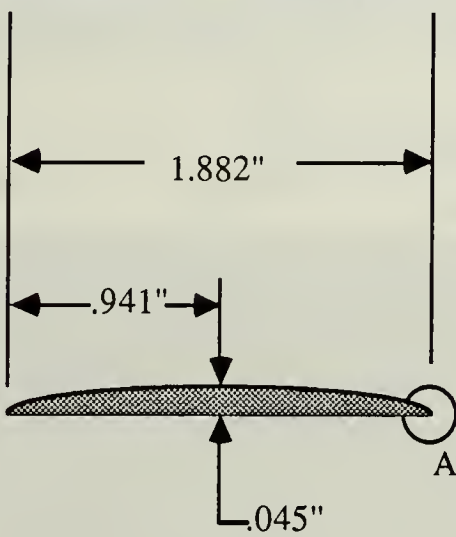
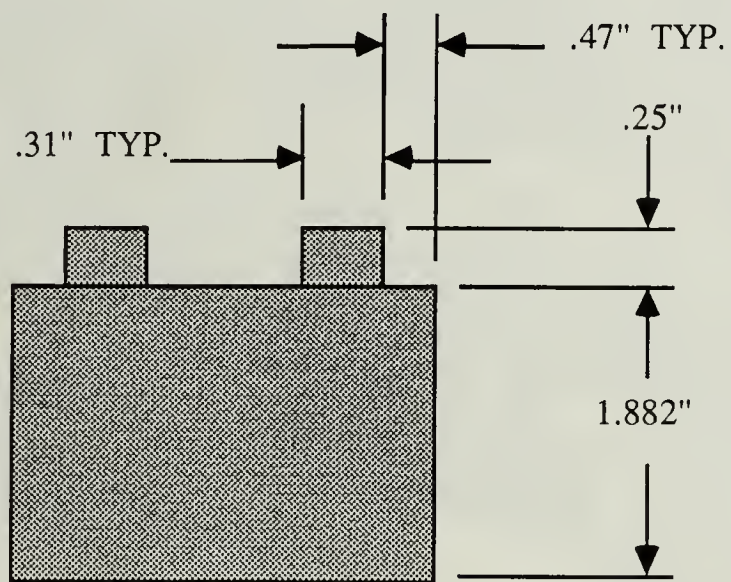
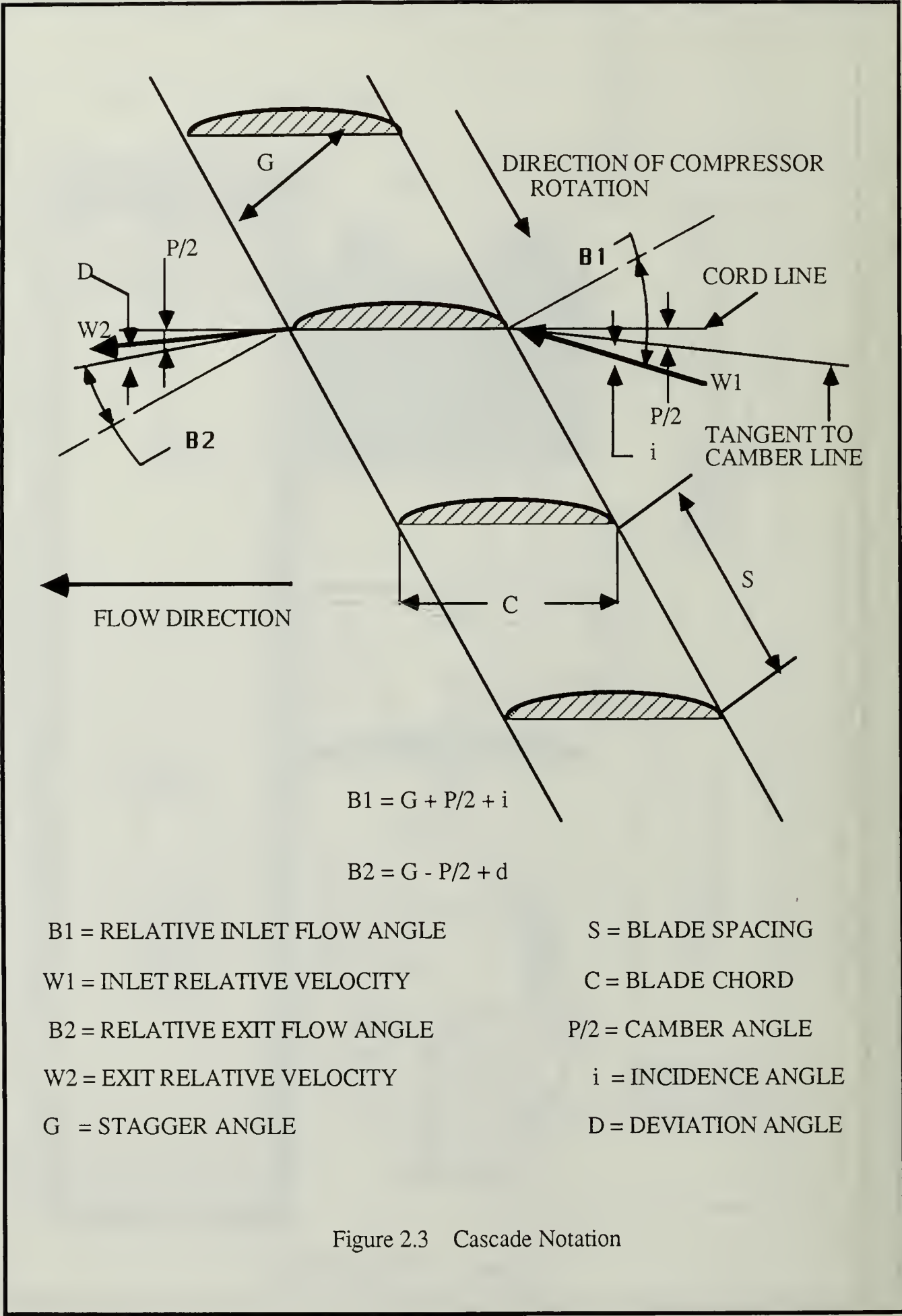

Figure 2.1 Mechanical Engineering Water Table



SECTION A

Figure 2.2 Cascade Blades



- | | |
|--------------------------------|---------------------|
| B1 = RELATIVE INLET FLOW ANGLE | S = BLADE SPACING |
| W1 = INLET RELATIVE VELOCITY | C = BLADE CHORD |
| B2 = RELATIVE EXIT FLOW ANGLE | P/2 = CAMBER ANGLE |
| W2 = EXIT RELATIVE VELOCITY | i = INCIDENCE ANGLE |
| G = STAGGER ANGLE | D = DEVIATION ANGLE |

Figure 2.3 Cascade Notation

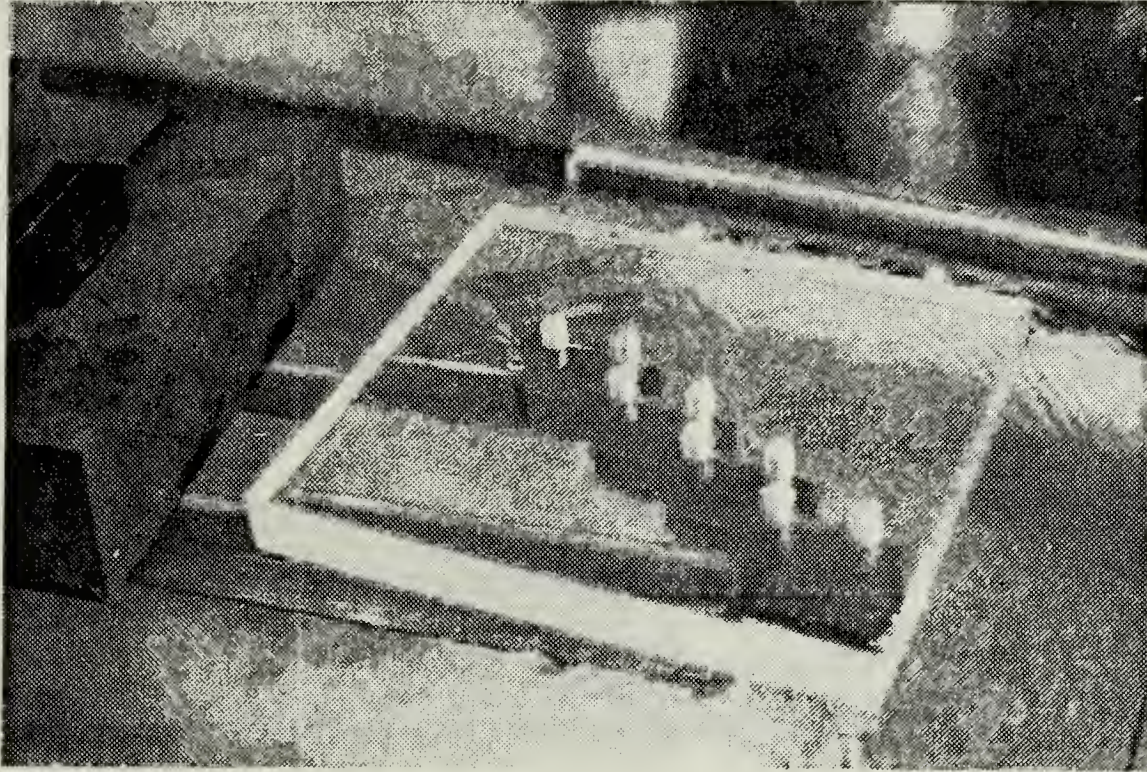

Figure 2.4 Cascade Mounting

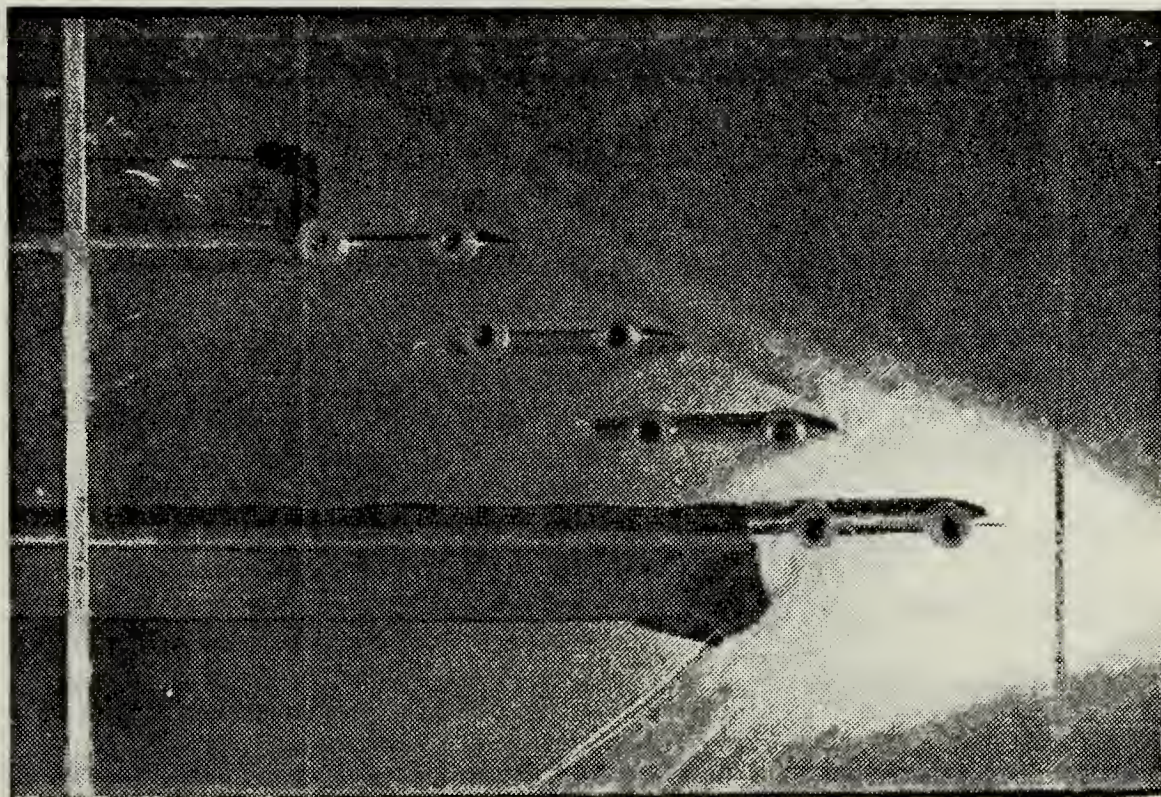

Figure 2.5 Outlet Tailboards

TABLE 2.1

COMPRESSOR ROTOR TIP AND CASCADE BLADE DATA

	<u>Compressor</u>	<u>Cascade</u>
Scale Factor (Z)	1	0.7
Stagger Angle (G)	59 deg, 44 min, 35 sec	59 deg, 44 min, 35 sec
Camber angle (P)	4.7 deg.	4.7 deg.
Blade Spacing (S), in.	1.920	1.344
Blade Chord (C), in.	2.688	1.882
Leading edge and trailing edge radii, in.	.005	.003
Suction side radius, in.	16.33	11.431
Maximum thickness, in.	.065	.045

The clay was molded to provide fairings along the outside edges. A range of turning angles for each incidence angle was examined with the intention of including in the observations the conditions which would be present at the rotor tip in the compressor. At each incidence and turning angle, the back pressure was varied to produce, as closely as possible, similar flow patterns within the blade passages.

D. BACK PRESSURE

The pressure rise across the cascade was controlled using a throttling valve in the flow channel downstream of the cascade.(Fig. 2.6 a & b) Back pressure increase was obtained by sliding a plate, held magnetically, down into the flow stream thus decreasing the exit area available through the flow passage. The decreased area could be varied to effectively choke the exit passage, causing upstream flow adjustment through a hydraulic jump. The jump, analogous to a shock wave in a gas flow, moved upstream as the valve was closed.

Sufficient back pressure variation was available to unchoke the cascade and to develop an entirely subsonic region throughout the blading, (Fig. 2.7).

E. DEPTH PROBE SURVEY EQUIPMENT

The depth probe survey instrumentation was designed to measure the variation in the height of flow surface through the test section. It consisted of a micrometer attached to a sliding survey arm which could be used at any point not obstructed by the cascade mounting (Fig. 2.8). The micrometer mounting bracket traversed the section on a stainless steel rail attached to Plexiglas endwalls. The micrometers were of the caliper type with a two inch throw graduated in thousandths of an inch.

F. SHADOWGRAPH AND DIRECT PHOTOGRAPHIC EQUIPMENT

A range of optical techniques was examined to observe and record the flow structure in the cascade. A mercury vapor continuous light source, focal plane shutter, two six inch parabolic and optical flat mirrors were used in attempts to photograph the various flow conditions in the test section using shadowgraph techniques. In addition, an optical filter and secondary fiber optic light source were used to adjust the back lighting to observe the hydraulic jump phenomena. The equipment was installed as shown in Figures 2.9-a and 2.9-b.

A Nikon 35 mm. camera with 80 mm. macro lens was used for the direct photography of the surface wave patterns and test section apparatus involved in this experiment.

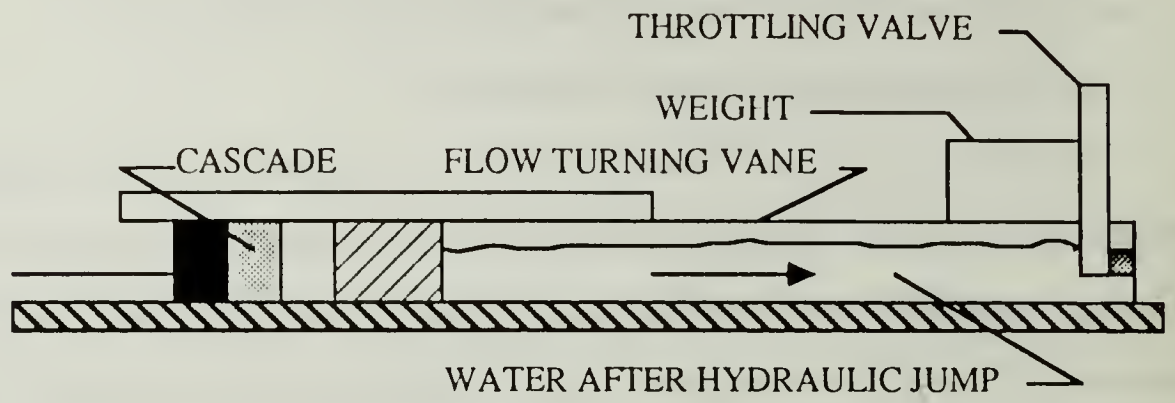

Figure 2.6a Profile View of Throttling Valve

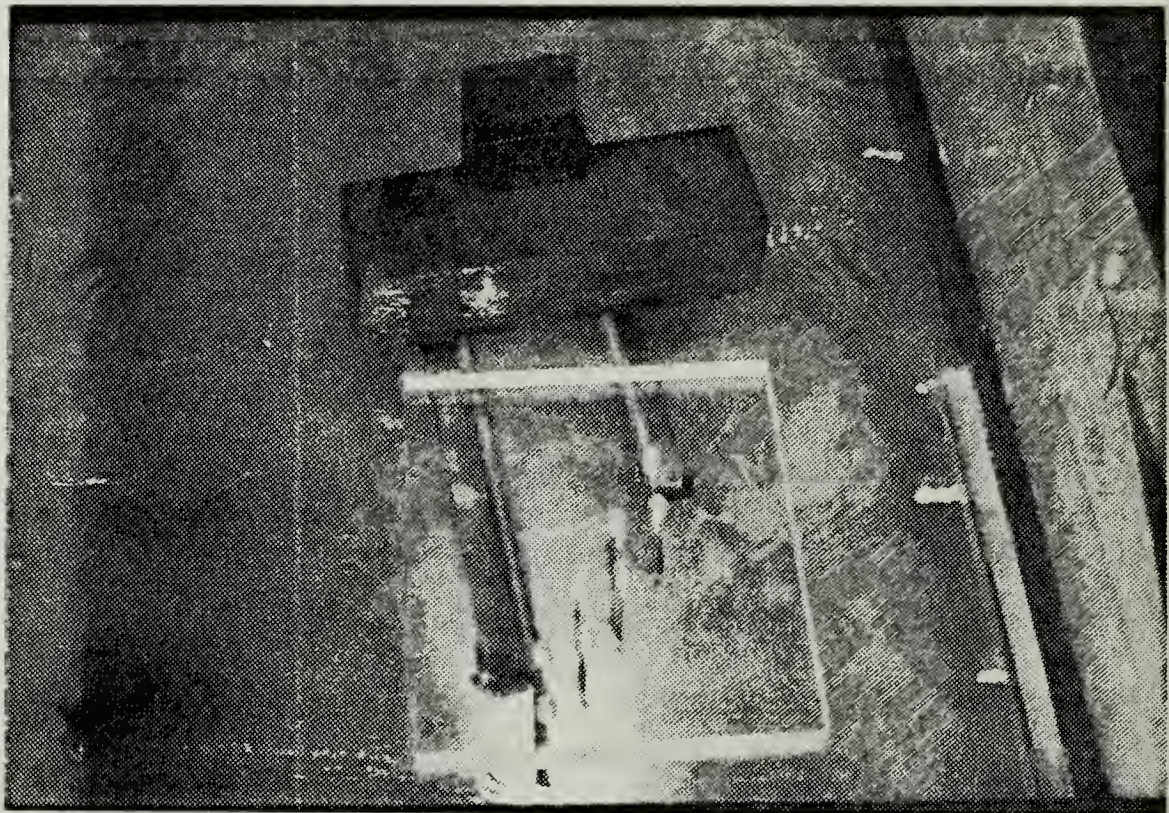

Figure 2.6b Top View of Throttling Valve

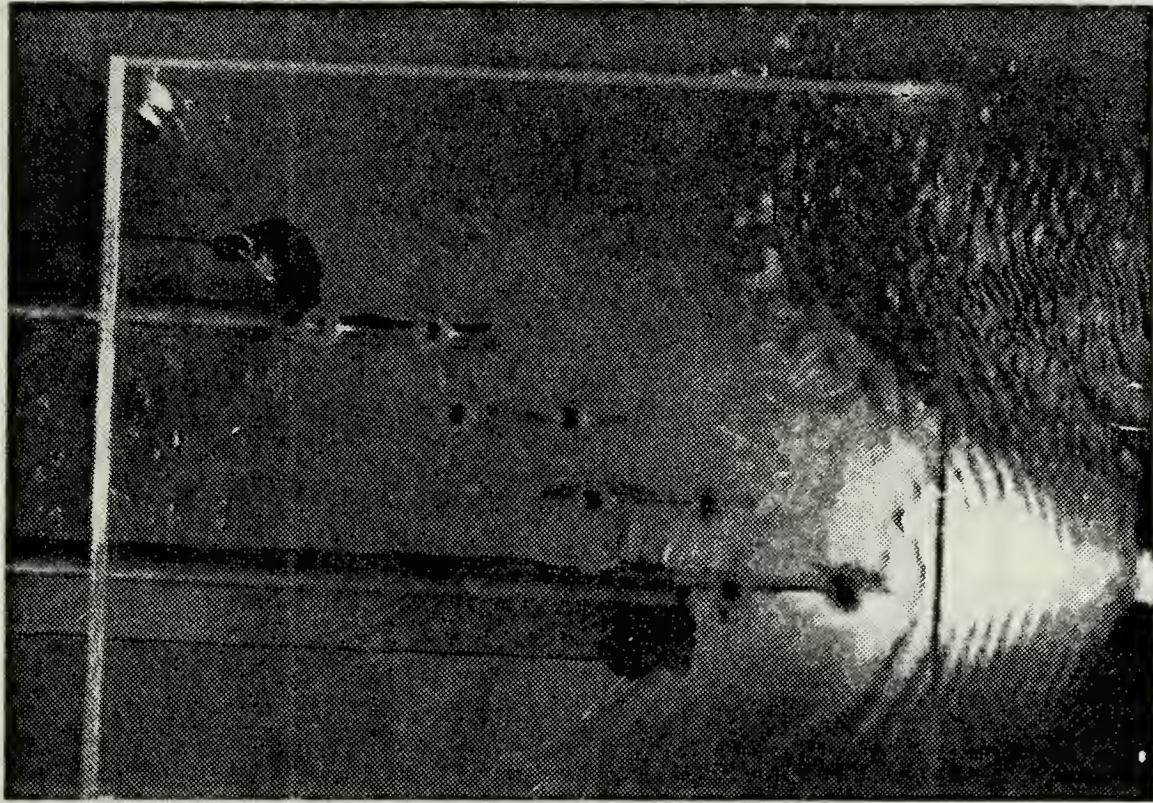

Figure 2.7 Unchoked Cascade

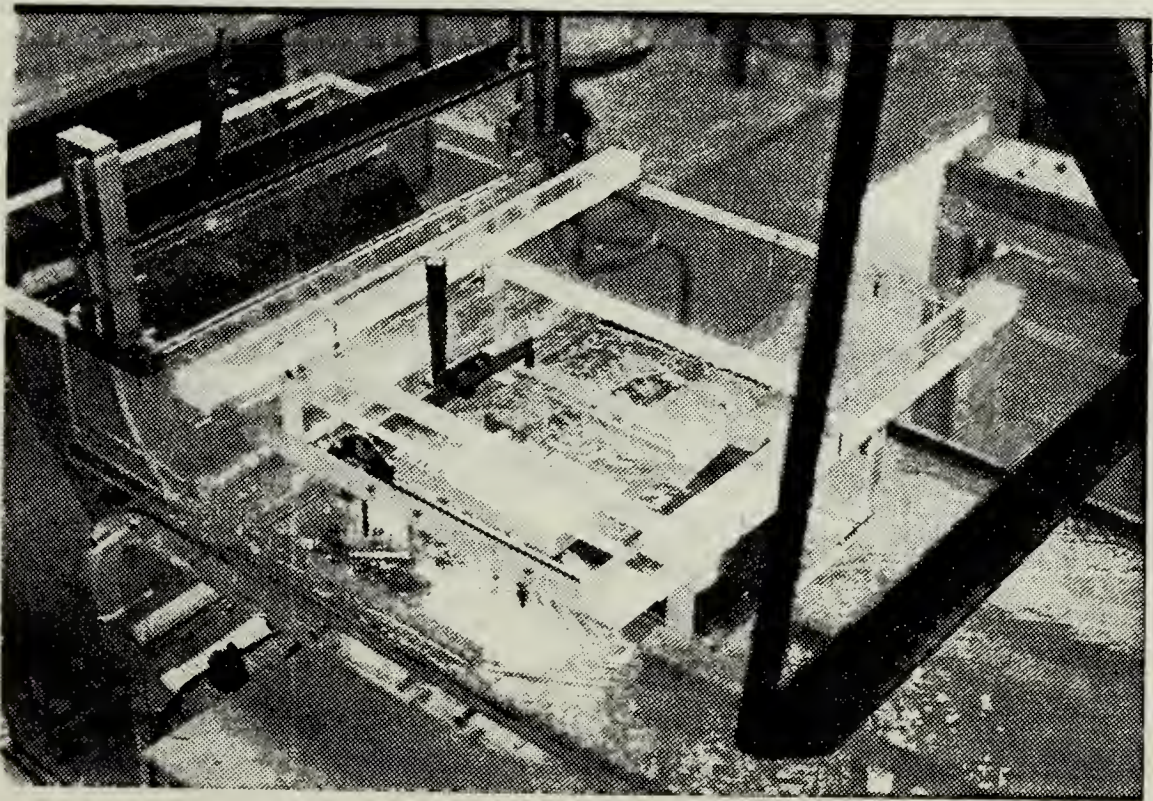

Figure 2.8 Depth Probe Survey System

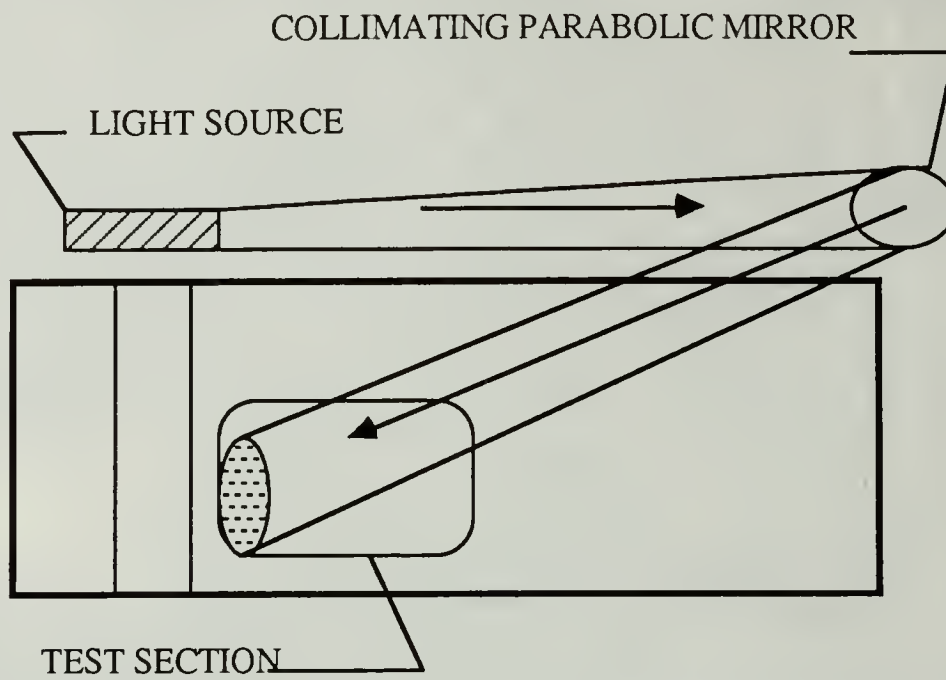

Figure 2.9a Plan View

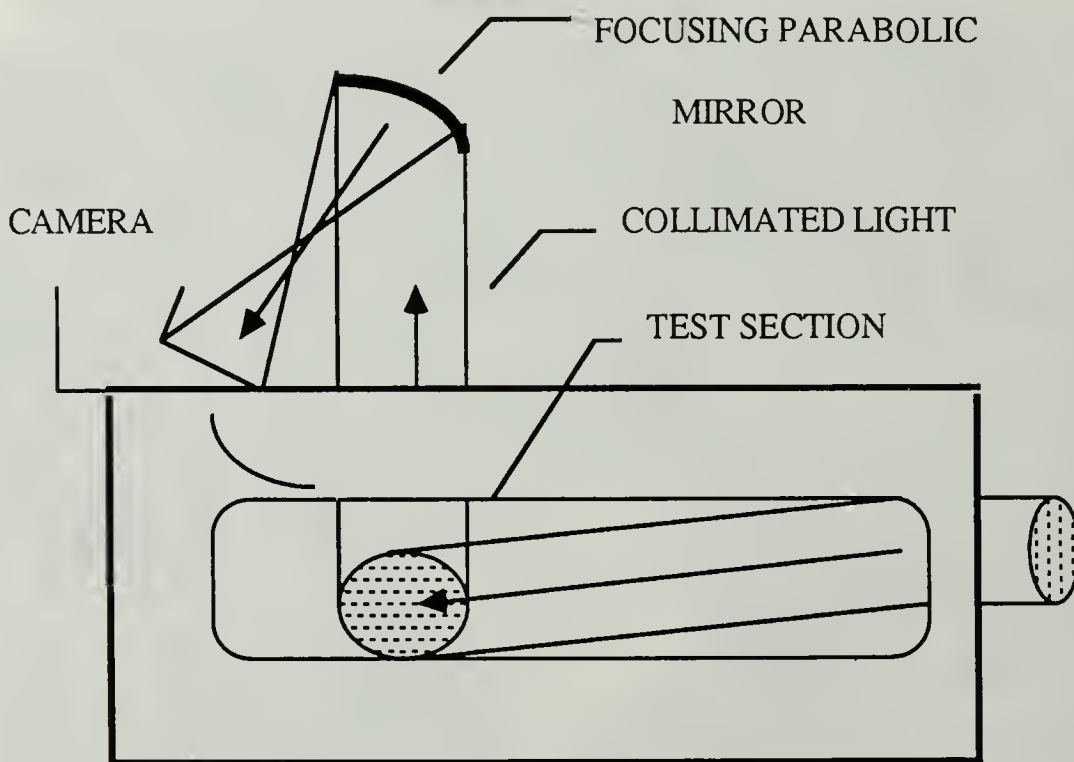

Figure 2.9b Profile view

Figure 2.9 Shadow Graph Arrangement

III. EXPERIMENTAL PROGRAM AND PROCEDURE

A. PRELIMINARY INVESTIGATIONS

1. Achieving proper flow conditions

Preliminary flow investigations on the water table (Appendix C) were made with both quarter circle and straight knife edged sluice gates to establish the proper flow conditions for the test section. In both cases the sluice opening was varied in 1/4 inch increments from 1/2 to 1 inch. The system pump was unable to supply sufficient flow for both the 3/4 and 1 inch openings hence the experiment was limited to a 1/2 inch sluice opening. The quarter circle sluice was chosen since it avoided the contraction of the test section depth caused by the knife edge sluice. No further reduction in sluice opening was investigated.

The test section was located approximately 2.5 inches downstream from the sluice and offset to one side to avoid choking the flow between the tailboards and the side of the water table. Choking in this region quickly caused sub-critical flow conditions to travel upstream to engulf the entire test section.

The maximum usable static test depth was 7/8 of an inch due to a natural oscillation of the water table which gave large fluctuations in the running condition with greater depths. Variations in test section static water depth appeared to have little effect on the running condition test depth which was fixed by the sluice opening. Static depths of less than 1/2 inch caused the pump to cavitate in trying to supply the required flow.

2. Recording flow structure

Several methods of recording the flow structure in the cascade were attempted. The first approach during the preliminary investigations was to use a video camera. This proved to be unsuccessful as the flow phenomena were not readily discernable in the video picture.

The second technique involved the use of a shadowgraph system. Shadowgraphs were attempted using the technique described in Appendix B and also with other combinations of lighting. These included the use of converging and diverging beams and attempts to light the cascade from the side, from the front, and from the back, in addition to direct light from underneath. The best pictures obtained were with the procedure outlined in Appendix B, however the shadowgraph pictures were also unusable as they did not clearly show the hydraulic jump relative to the cascade blades. Figure 3.1 shows a representative picture of the best quality shadowgraph that was obtained.

Direct photography was at first ruled out because of the poor quality of the video images obtained in the preliminary investigations. Photographers from the NPS Photo Division were consulted and a relatively simple arrangement using a beige colored background with white backlighting was attempted successfully. A Nikon 35 mm camera with 80 mm macro lens was used for the photography. The macro lens provided the necessary detail for recording the hydraulic jump. This technique was adopted to record the changes in the wave structure for the variations in flow angle, turning angle, and back pressure.

B. CONTROLLED VARIATIONS IN FLOW ANGLES AND BACKPRESSURE

The calculated minimum loss incidence angle for the compressor blading was 0.9 degrees [Ref. 3] with reference to the camber line of the blade. The flow was examined at various angles of incidence around this minimum loss condition. Due to practical limitations, the accuracy of blade settings on the water table was limited to $\pm 1/2$ degree. Three incidence angles were observed, -2.8, 0.9, and +2.8 degrees.

Since the flow turning angles and associated pressure rises in the transonic compressor had not been measured at relative inlet Mach numbers greater than about one, a series of imposed flow turning angles were investigated on the water table for each incidence angle condition.

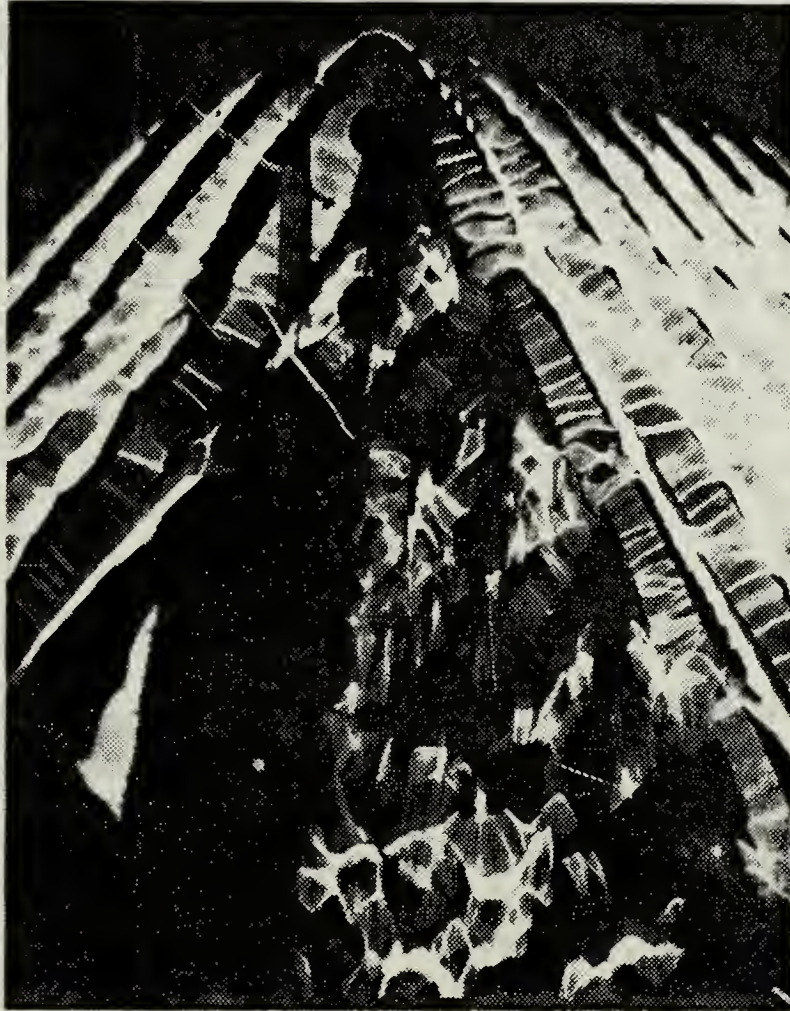

Figure 3.1 Representative Shadowgraph Photograph

Flow turning angle changes in 2 degree increments from 4 to 8 degrees were set with the thought that the conditions prevailing in the compressor would be within this range. The compressor design flow turning angle was 4.01 degrees. Measurements from the transonic air cascade recorded average turning angles of 4 to 6 degrees for pressure ratios of 1.006 and 1.51 respectively [Ref. 3:pp 23]. For this reason the initial flow turning angle was set at 6 degrees, with variation up to 8 degrees and down to 4 degrees.

IV. RESULTS

A. FLOW CHARACTERISTICS

Twenty-three test runs with incidence angles of -2.8 , 0.9 , and $+2.8$ degrees were investigated. Over one-hundred photographs of the flow patterns were taken at the various operating conditions imposed on the cascade. From these test conditions a representative sample of the flow at each of the three incidence angles is discussed below. Samples of the remaining photographs are given in Appendix E, with corresponding data from each condition listed below the picture and summarized in Table E.1.

Inlet relative "Mach" number was 1.64 to 1.71 as measured from the photographs. Lower relative "Mach" numbers were not obtainable due to disturbances from hydraulic jumps occurring in the passages adjacent to the model. These "shocks" moved upstream and unchoked the cascade.

The amount of flow turning imposed by the tailboards had no effect on the leading shock angle which formed in the cascade passages. However, with increased flow turning less back-pressure was required to locate other shocks in the passage and to unchoke the cascade.

In all cases, when the leading shock was located in the blade passage it was an oblique shock. The leading shock only became normal and moved forward of the model as the cascade was fully unchoked. This occurred after the outlet flow had become subsonic.

Oscillations inherent to the water table caused fluctuations in the inlet flow velocities. Despite this effect a repeatable pattern for the shock was documented.

Figures 4.1a through 4.1c show representative photographs of the shock structure at incidence angles of -2.8 , 0.9 , and $+2.8$ degrees respectively.

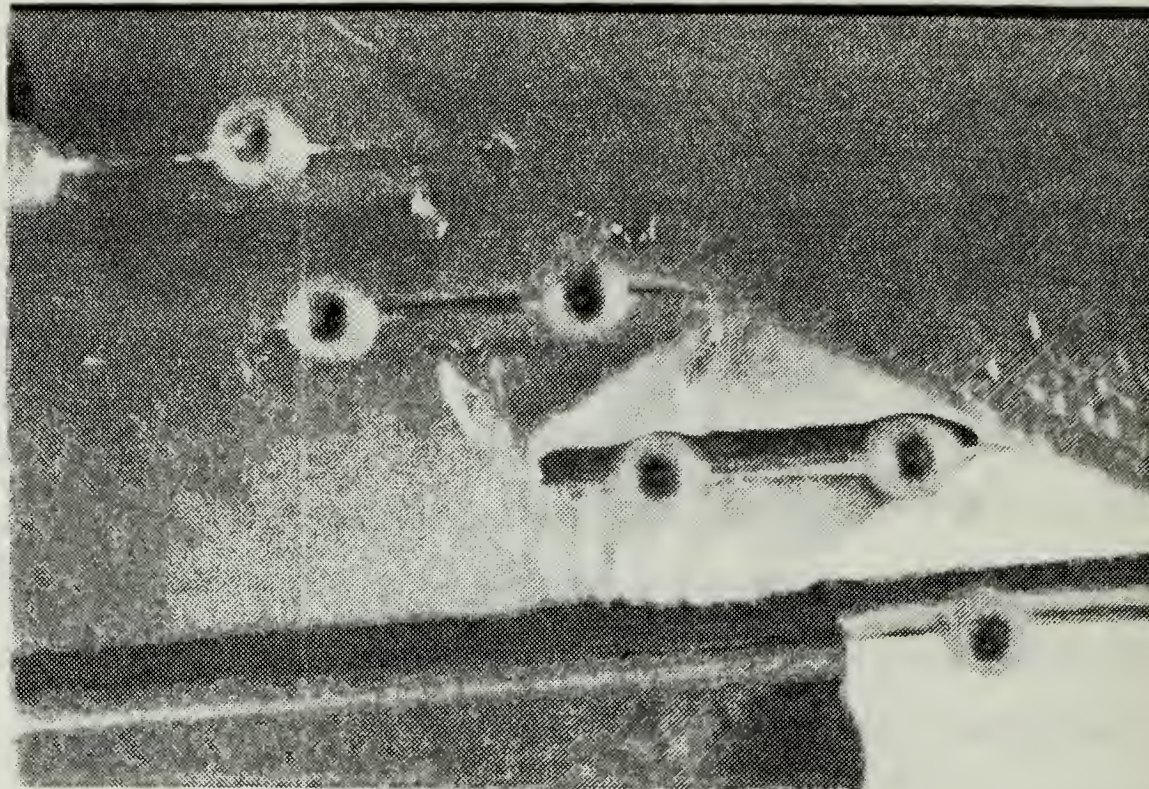

Figure 4.1a Incidence angle = -2.8°

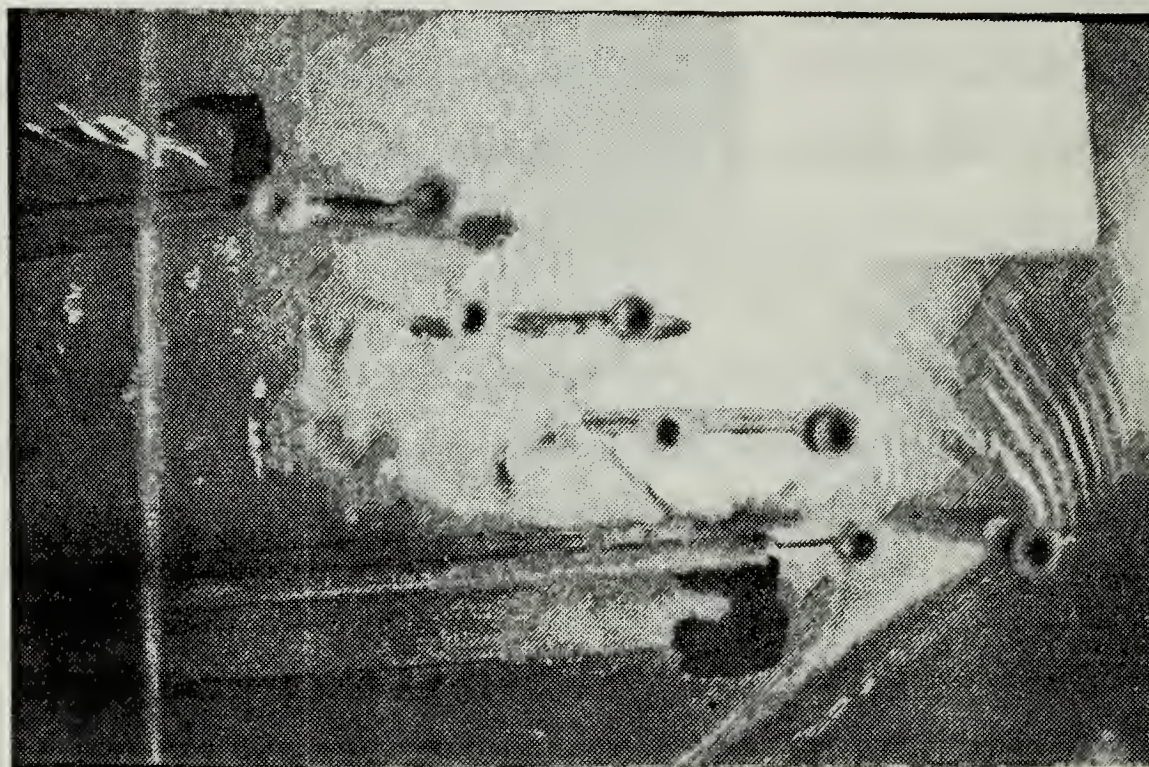

Figure 4.1b Incidence angle = 0.9°

Figure 4.1 Representative Cascade Flow Photographs

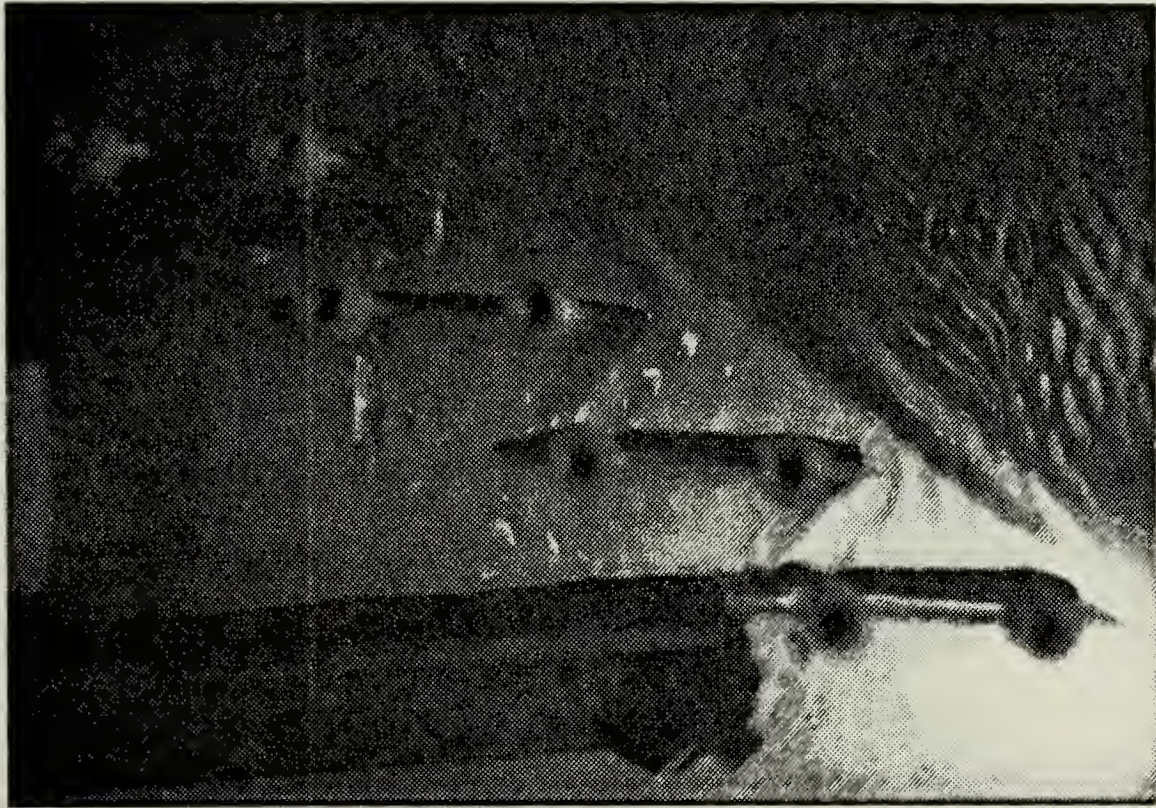

Figure 4.1c Incidence angle = + 2.8°

B. QUANTITATIVE ANALYSIS

The calculation of average pressure ratios across the cascade by means of the hydraulic analogy resulted in a pressure ratio of approximately 2.85 for Figure 4.2. This was based first on deriving the inlet Mach number from measurements of the oblique shock angle generated from the leading edge on the pressure surface of the blade [Ref. 4]. From the Mach number and the depth measurements, Figure A.1 in Appendix A, was used to find the corresponding outlet Mach number and hence the pressure ratio for the cascade corrected for a gas with a specific heat ratio of 1.41.

This calculated pressure ratio was unusually high as the compressor design estimates the design pressure ratio to be about 1.5. It is noted that the hydraulic analogy is based on isentropic flow and "shallow water " implies uniform velocity with depth. It is mentioned in references to the hydraulic analogy [Ref. 5 & 6] that, the analogy does not always give good quantitative results. It was thought likely that the very high pressure (depth) ratios, associated with the production of transonic changes through strong waves, must severely strain the assumptions of the analogy.

V. CONCLUSIONS

An attached oblique shock was observed to form on the pressure side at the leading edge of the blading. Shock impingement location on the suction surface of the blading was a function of the flow turning angle and back-pressure.

The cascade model did not fully represent an "infinite" cascade. Additional blading should be used to more closely model the compressor flow.

Variations in the passage to passage flow structure were attributed to a decrease in the relative Mach number of the flow due to losses as a function of distance from the sluice gate. These losses were assumed to be caused by friction on the water-table surface.

Despite these problems the use of a water table for visualization of flow structure is strongly recommended due to its ability to provide good qualitative information inexpensively and quickly.

APPENDIX A
HYDRAULIC ANALOGY

The theory for the hydraulic analogy of a two dimensional compressible gas flow initially developed by Riabouchinsky and continued by Preiswerk [Ref. 5] has been examined and with some reservations [Ref. 6], the analogy is seen to provide, in the water table, an economical tool to model both quantitatively and qualitatively the flow of a compressible gas about a two dimensional object.

The theory is developed with the assumption of ideal fluids and perfect gases. Therefore, departures due to real fluid effects occur and the calculations do not model the flow completely.

Two types of waves are present for any disturbance in the flow, capillary waves and gravity waves. The capillary waves are of low amplitude and easily distinguishable from the larger gravity waves. With the assumption of zero surface tension the wave velocity equation is given by;

$$\lambda = (gd)^{1/2}$$

where:

λ = surface wave velocity

g = local acceleration due to gravity

d = depth of flow.

which is analogous to the sonic velocity in a gas.

Figure A-1 shows corresponding variations of pressure ratio in the gas and analogous depth ratio in water with Mach number. Table A.1 is a summary of analogous quantities used in the interpretation of data.

DEPTH & PRESSURE RATIO VS MACH

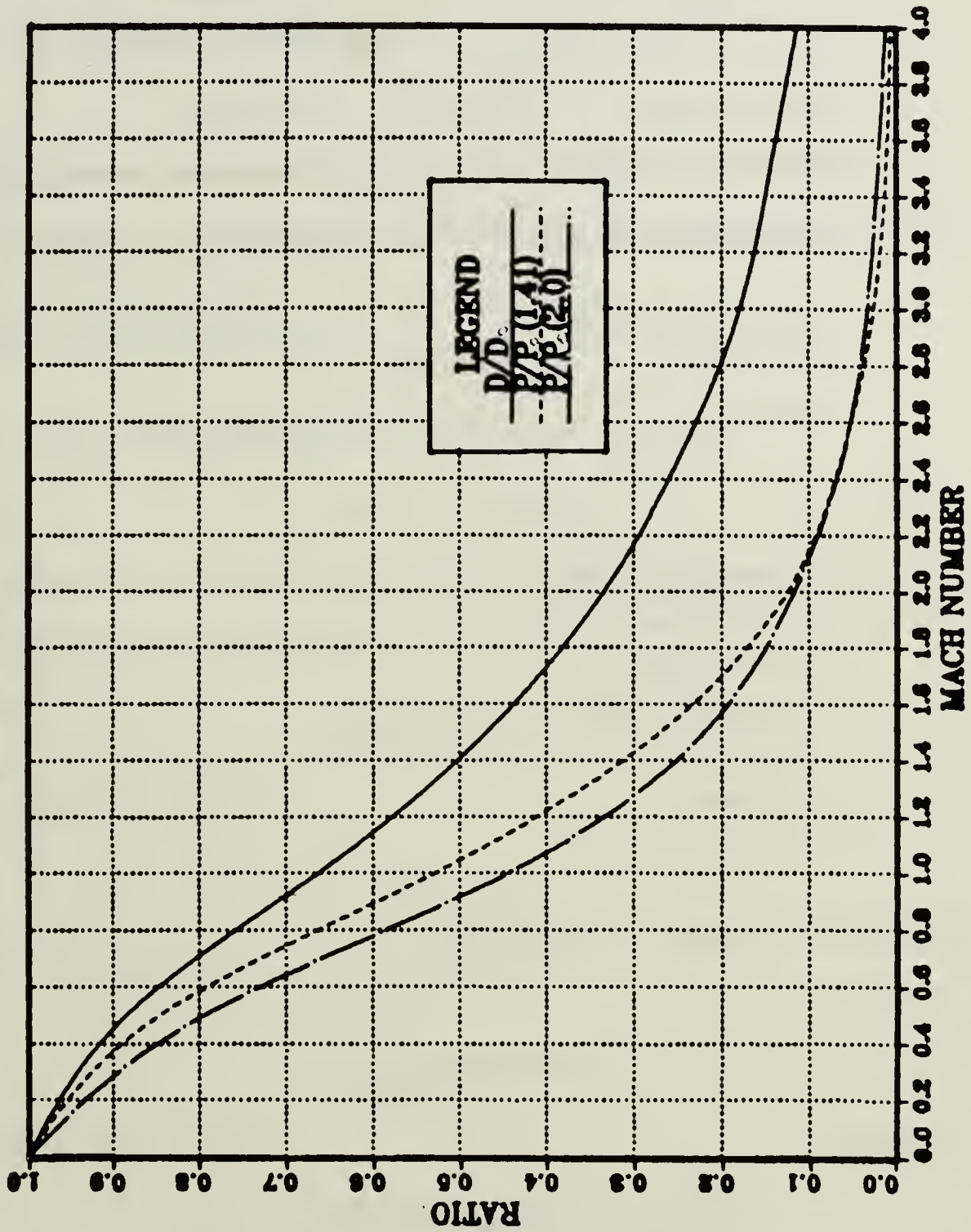

Figure A.1 Pressure and Depth Ratio vs. Mach Number

TABLE A.1

HYDRAULIC ANALOGY PARAMETERS

<u>Gas</u>	<u>Liquid</u>
Temperature ratio, T/T_0	Depth ratio, d/d_0
Density ratio, ρ/ρ_0	Depth ratio, d/d_0
Pressure ratio, P/P_0	Square of depth ratio, $(d/d_0)^2$
Sonic velocity, $a = (\gamma P/\rho)^{1/2}$	Surface wave velocity, $\lambda = (gd)^{1/2}$
Mach number, $M = V/a$	Froude number, $Fr = V/(gd)^{1/2}$
Shock wave	Hydraulic jump

where:

1. γ - specific heat ratio
2. g - acceleration due to gravity
3. T - temperature
4. V - velocity of fluid
5. P - pressure
6. d - depth
7. ρ - density of the fluid

and subscript 'o' denotes the reference value.

For a gas

$$V^2 = 2gc_p(T_0 - T)$$

and therefore

$$V_{\max} = (2gc_p T_0)^{1/2}$$

For liquid,

$$V^2 = 2g(d_0 - d)$$

and therefore

$$V_{\max} = (2gd_0)^{1/2}$$

For either the gas or the liquid, define

$$V/V_{\max} = X$$

where X is the nondimensional velocity. For an analogous flow of water, (having the same values of X), from the above equations it is seen that the depth ratio is related to the temperature ratio in the gas by

$$d/d_0 = T/T_0$$

The continuity equation for shallow water flow can be written as

$$\partial(uv)/\partial x + \partial(vd)/\partial y = 0$$

where u and v are the components of the velocity in the x and y directions. The continuity equation for a compressible gas flow is

$$\partial(u\rho)/\partial x + \partial(v\rho)/\partial y = 0$$

An analogy can exist only if

$$d/d_0 = \rho/\rho_0$$

for a perfect gas therefore, an analogy can exist if

$$P/P_0 = \rho T/\rho_0 T_0 = (d/d_0)^2$$

If the gas flow is isentropic

$$P/P_0 = (T/T_0)^{\gamma/(\gamma-1)}, \text{ or equivalently } (d/d_0)^{\gamma/(\gamma-1)}$$

Thus an analogy can exist only if

$$(d/d_0)^2 = (d/d_0)^{\gamma/(\gamma-1)}$$

which implies that $\gamma=2$. Since air has a specific heat ratio of 1.41 the analogy is only quantitatively approximate. Exact correlations for water-table data to analogous air flows have not been developed as yet. However close qualitative agreement exists for observed wave patterns and the analogy is generally used for this purpose.

Three classifications of the hydraulic jump have been defined, based on observations. The jump characteristics are related to the measured Froude number of the flow as follows;

1. Undular jump (Fig. A.2a). A smooth expansion of the flow followed by oscillations, resulting in a smooth first wave followed by waves of decreasing amplitude. This type of jump has very little loss associated with it, and occur in the Froude number range of $1.0 < Fr < 1.7$.
2. Transitional jump (Fig. A.2b). This jump occurs between Froude numbers of $1.8 < Fr < 3.0$ and is characterized by a first or second wave cresting, followed by smoother waves of undular motion. An increased energy dissipation occurs compared to the undular jump.
3. Direct jump (Fig. A.2c). This type of jump can occur in flows with a Froude number, $Fr > 2.5$ and is associated with large losses and heavy flow reversals along the surface of the wave. It is a large wave in magnitude and usually stands alone as a single discontinuity in the flow. It is characterized by 'white water' as air is entrapped in the turbulent reverse roller on the face of the wave.

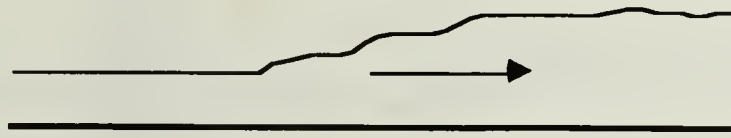

Figure A.2a Undular Jump



Figure A.2b Transitional Jump

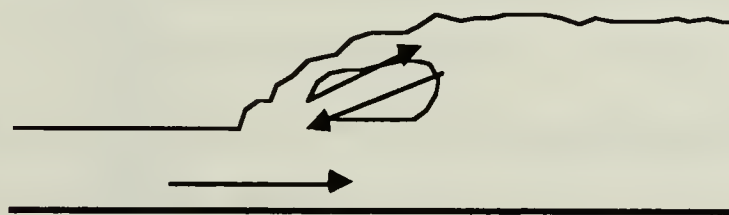

Figure A.2c Direct Jump

Figure A.2 Hydraulic Jump Characteristics

APPENDIX B
SHADOWGRAPH TECHNIQUE

Figure B-1 shows the schematic of a simple parallel-light shadowgraph system. Light from a point source is collimated by a lens or parabolic mirror and passed through the test section onto a screen or photographic plate. As the light rays traverse the test section they are refracted by the density gradients in the flow. If there are density gradients present in the test section the refraction will not be uniform and areas of light concentration and areas of shadow will appear on the screen. Since the intensity on the film is a result of an integral of the light deflection across the test section, the extraction of quantitative information is usually difficult.

For the shadowgraph to be useful, density gradients must exist in the flow and the stronger the gradient the greater will be the contrast in the image. The screen must be located very close to the test section or the surfaces in the test section will not be adequately focused on the film, unless an additional parabolic mirror is used.

The shadowgraph is inexpensive and relatively easy to use. However, the addition of optical mirrors or lenses, if the screen can not be placed sufficiently close to the test section, can require tedious focal adjustment. In addition, shadowgraph systems may not be appropriate for flows with large density gradients and path lengths.

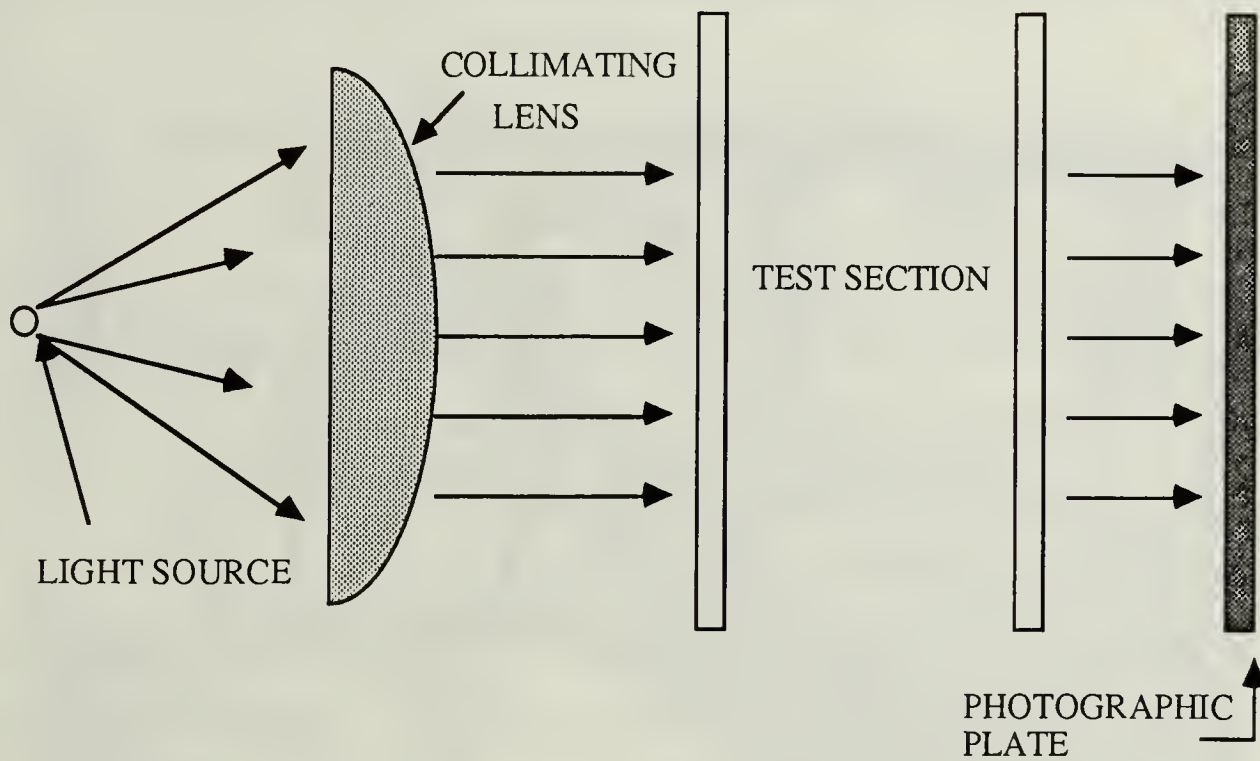

Figure B.1a Constant Density Flow

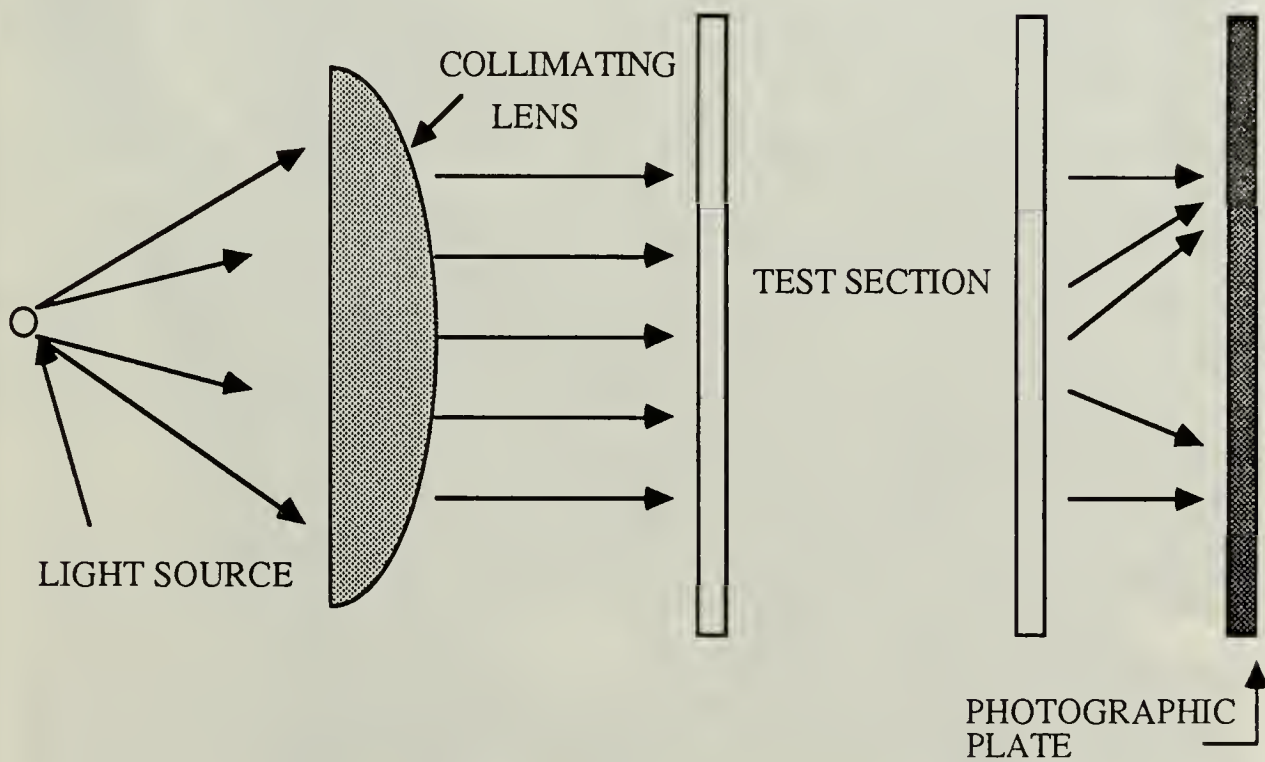

Figure B.1 b Flow with Density Gradient

Figure B.1 Shadow Graph Formation

APPENDIX C

WATER TABLE AND OPERATING PROCEDURES

The mechanical engineering (M.E.) free surface water table used in the present investigation was located in the hydrodynamics laboratory of Halligan Hall, Naval Postgraduate School (NPS). The installation was designed and built to the specifications of Dr. Sarpkaya as a subsonic flow visualization system.

The water table (Fig. C.1) was a vertical return closed circuit design with overall dimensions of 96 inches in length by 22 inches in width. The table was constructed of 1 inch Plexiglas with a test section 20 inches wide by 71 inches in length. A plan view through the test section is shown in Figure C.2. The section was horizontal with the capability of tilting in the downstream direction to overcome shear losses on the test surface. The degree of maximum tilt was approximately 10° achieved by the use of a base mounted hydraulic jack installed under the upstream end-wall.

A one and one-half horsepower variable speed AC-motor (Fig. C.3) was coupled through a reduction gear and pulley-belt drive system to an impeller of in-house design. The speed adjustment was provided by a lever arm located on the reduction gear housing mounted to the drive motor. The motor was able to provide transonic flow through the sluice gate and test section to a depth of 1/2 inch.

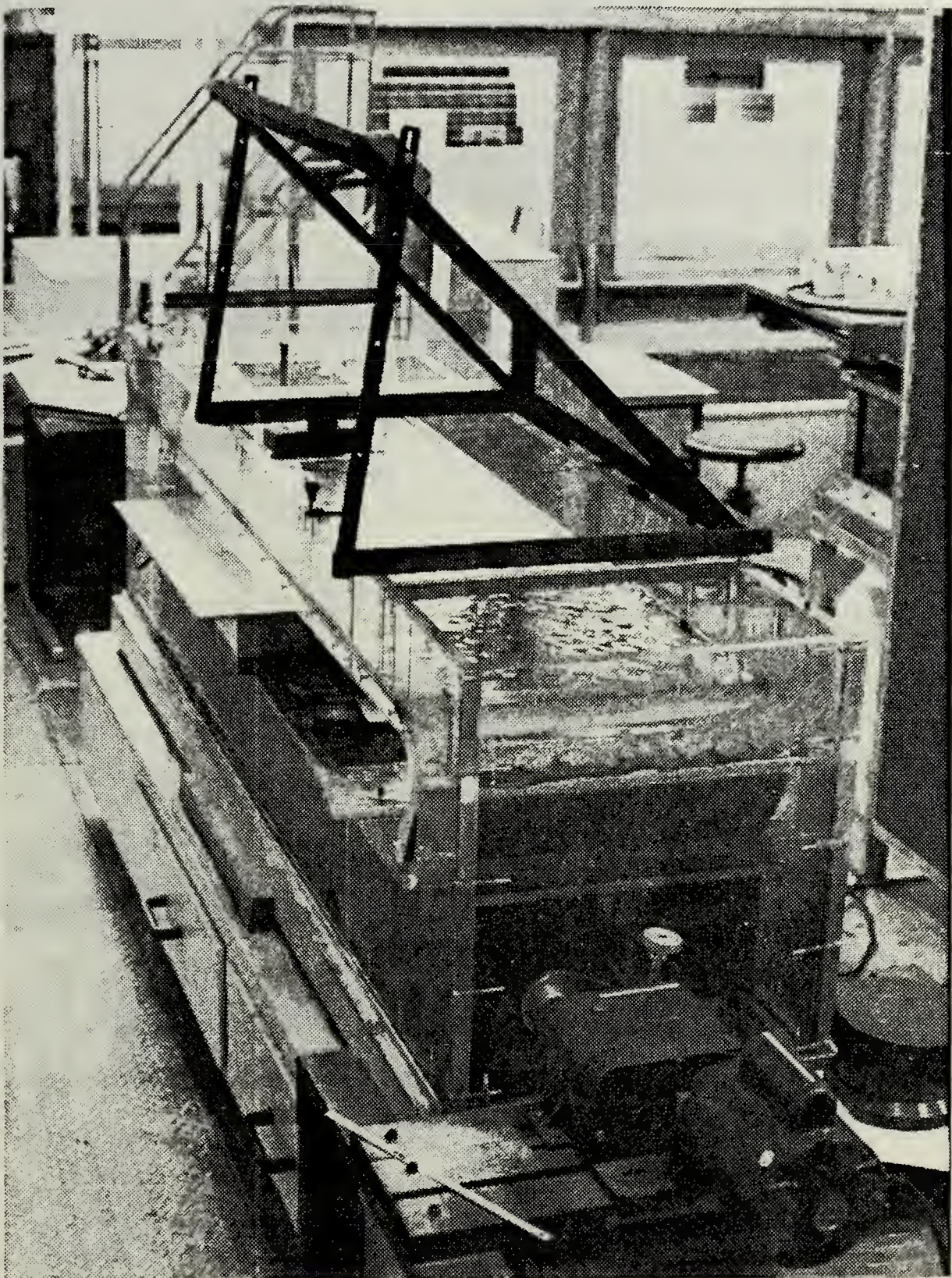

Figure C.1 Water Table

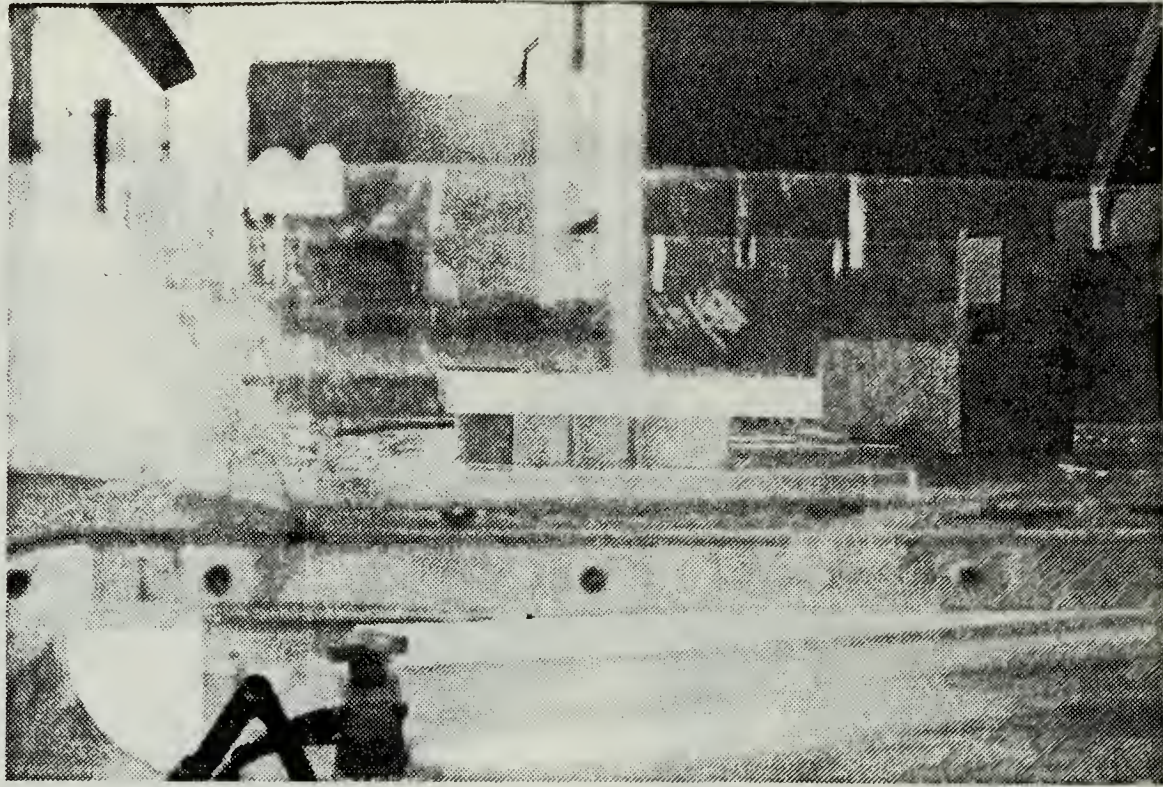

Figure C.2 Profile View of Test Section

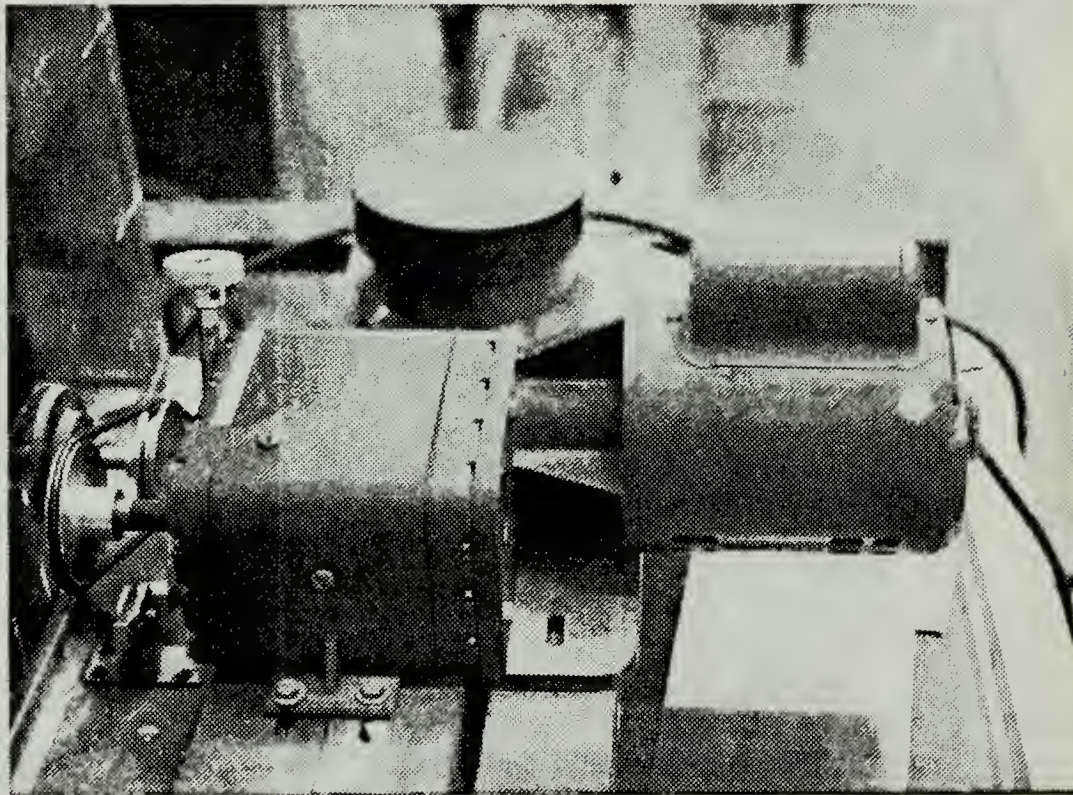

Figure C.3 Water Table Drive System

Modifications to the table were carried out to provide the necessary flow conditions for the experiment. These consisted of:

1. installing aluminum honeycomb flow straighteners downstream of the impeller and upstream of the sluice gate.
2. installing a circular sluice gate to accelerate the flow to the desired flow speed with minimal losses. A straight sluice gate with a knife-edged exit channel generated a reduction in flow height leaving the sluice, giving a "coefficient of contraction" of approximately 0.61 whereas a circular sluice gave no contraction.
3. installing a honeycomb straightener in the return settling chamber also before the impeller to help dampen flow oscillations due to the natural frequency of the system.

Commercial dishwasher detergent, on the order of 0.1% volume, was added to reduce the surface tension. No antifoaming agent was necessary due to the inherent antifoaming characteristics of the soap.

The water table was filled and drained by 1.5 inch diameter PVC piping connected to the laboratory water supply and under floor drainage system.

The location of the model in the test section was adjusted so as not to choke the flow in the side passages adjacent to the model during operation. This was a trial and error process when the flow turning vanes were installed since they were required to be adjusted during the testing, and this sometimes required relocation of the model. Once the model was located in the test section, measurements of the static depths were made.

The operation of the water table was straight forward. The lever arm controlling the motor speed was positioned to the lowest speed position before turning on the pump. This was to prevent a large surge and subsequent cavitation of the pumping system, which introduced bubbles into the water. A two position toggle switch located on the drive motor was then actuated to start the water table. The speed control arm was positioned to give the desired flow conditions.

During the initial operation of the system it could take up to 45 minutes to remove the bubbles trapped in the honeycomb flow straighteners as a result of filling the table. Once the bubbles were expelled from the system and the flow was stabilized, measurements of the running depths could be made. From this information the overall average pressure ratios and operating Froude number were obtained from the upstream and downstream water depths.

Measurements of the flow depths were made with both a thin metal tape and using a channel depth probe survey system incorporating micrometers capable of measurements to a thousandth of an inch.

Due to the unsteadiness in the pumping system, the vertical tape measurements rather than the micrometer measurements were used to determine the time-averaged operating conditions.

APPENDIX D
AERO-ENGINEERING WATER TABLE

The construction of a water table at the Turbo-propulsion Laboratory, Department of Aeronautics specifically to be used for cascades, involves first the choice between two possible approaches; namely, the water table can be constructed to provide a continuous flow at a constant speed or the model can be towed through a stationary fluid at a desired test speed. Table D-1 lists the advantages and disadvantages of each type of system.

The construction costs and tolerances involved are much less for a closed circuit table with moving fluid. The operation of such a table is also much simpler in terms of set-up and running. Considerations which must be taken into account before constructing a water table include the following:

1. The number of blades to be modeled which will dictate the length and width of the water table. It should be of sufficient width so as not to choke the flow in the side passages of the model. This can be accomplished by either a diverging channel downstream of the model or by siphoning fluid along the walls of the water table.
2. The flow depth for the running condition and the type of sluice gate which will produce the flow must be considered.
3. The cascade should be mounted such that the flow depth can be measured easily throughout the blading and well downstream.
4. The tailboards, unless another means of flow turning is developed, must be attached so as to be easily adjustable to the desired conditions.
5. Determination of how the fluid will be returned to the reservoir and the rate at which this is accomplished must be considered carefully. Flow stabilization is of primary importance.
6. Appropriate flow measurement devices must be used to conform to the type measurements needed. (i.e., total hydraulic head, depths before and after transitions, and flow speeds.)
7. The desired rate of flow, to dictate the size of pump required and possibly the type, i.e. centrifugal or a screw impeller located in the return duct

8. Flow losses, where they occur and how to overcome or these by adjusting the flow conditions
9. Plexiglas and other combinations of materials should be considered to optimumly satisfy design requirements at minimal cost.

A schematic plan suggesting a layout for the test section of a suitable table is presented in Figure D.1.

TABLE D.1

COMPARISON OF WATER TABLE TYPES

<u>WATER TABLE TYPE</u>	<u>ADVANTAGES</u>	<u>DISADVANTAGES</u>
moving model	<ul style="list-style-type: none"> - stationary fluid causes no problems with hydraulic jump formation near the transonic region 	<ul style="list-style-type: none"> - difficult to read depth changes. must use cameras mounted on sliding arms moving with model and triangulate depths - tolerances between model and water table floor are critical for proper flow - table must be very long to start flow phenomena then record information - there are possible vibration problems associated with the towing system - long period between runs for fluid to settle voricities
fixed model	<ul style="list-style-type: none"> - low cost - easy to build and use - can measure flow depths directly - runs continuously - fewer problems with model vibration - Size of table required is not nearly as long as towed model table 	<ul style="list-style-type: none"> - hydraulic jump problems associated with transonic flow may unchoke cascade - table may have natural frequency oscillations which may or may not be controllable

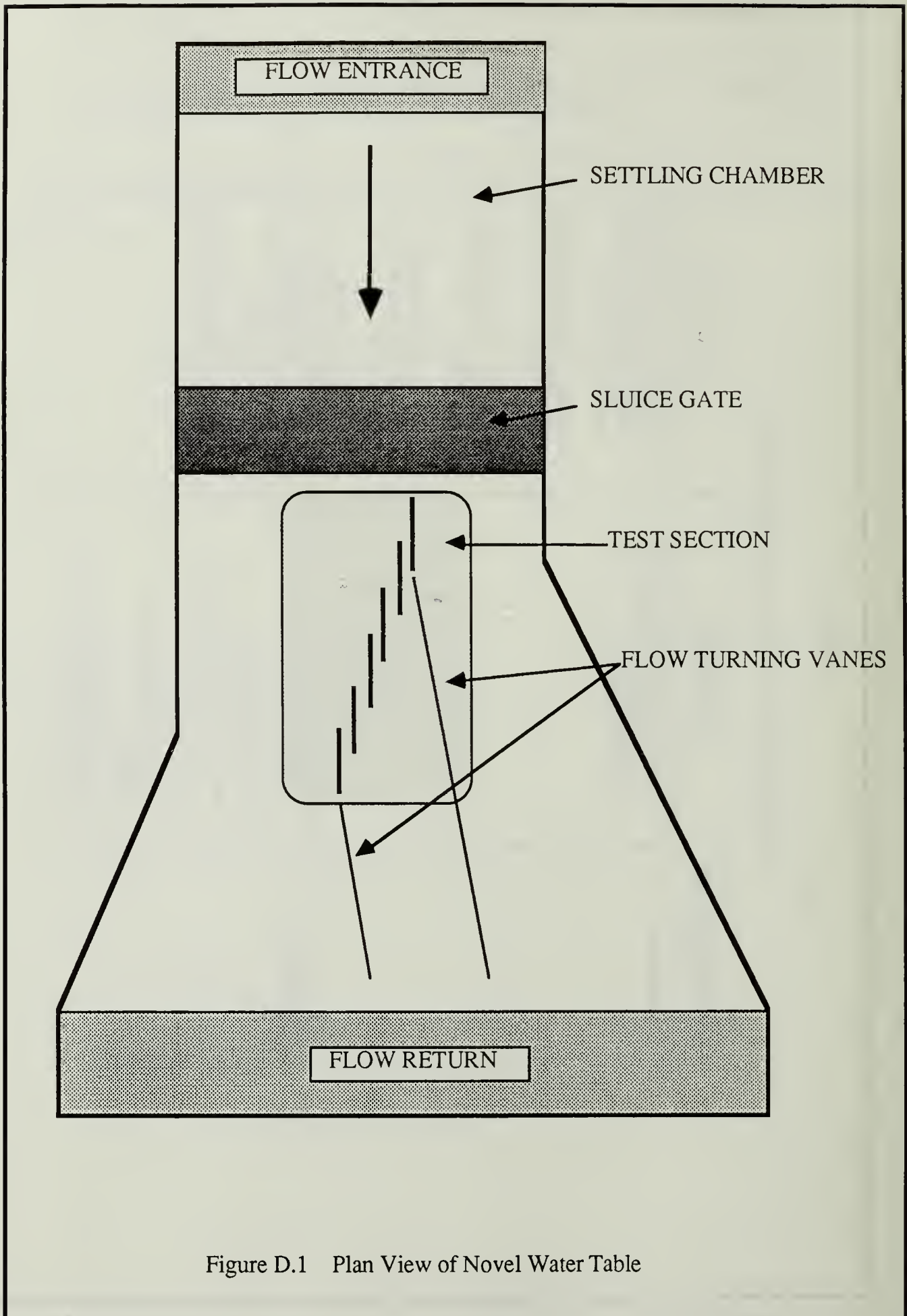

Figure D.1 Plan View of Novel Water Table

APPENDIX E

COMPENDIUM OF PHOTOGRAPHIC DATA

A representative test data sheet (Figure E.1) and the corresponding test photographs are given to illustrate the test procedures and results. A compendium of various photographs labeled to show corresponding incidence and flow turning angles are also given. The notation used on the photographs is as follows:

i = incidence angle

$\Delta\beta$ = flow turning angle

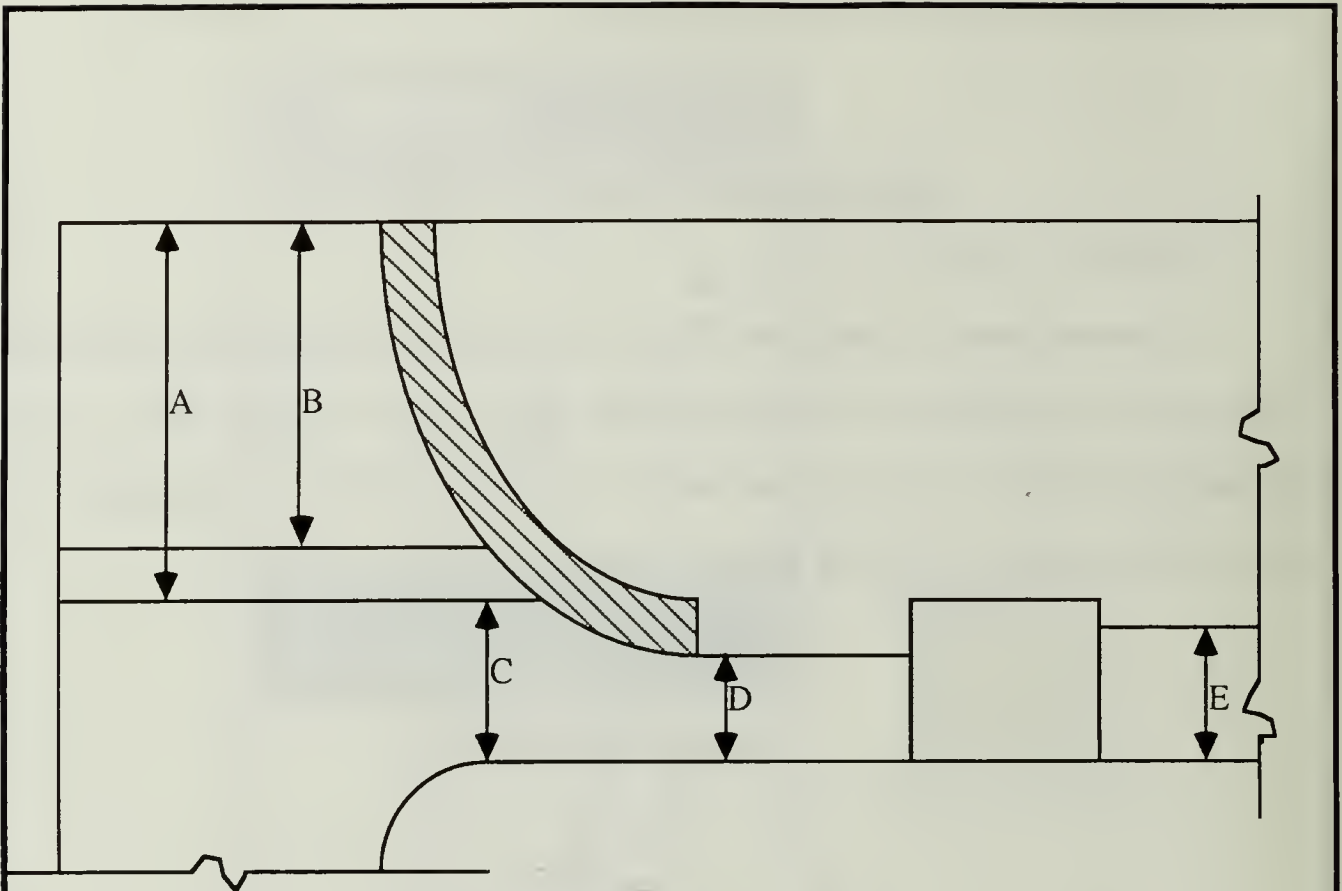

INCIDENCE ANGLE = 0.9 degree
 TURNING ANGLE = 6 degrees
 STATIC WATER DEPTHS A = $5 \frac{4}{16}$ "
 C = $11/16$ "

RUNNING WATER DEPTHS

<u>B</u>	<u>D</u>	<u>E</u>	<u>TEST FRAME</u>
5	9/16	12/16	1*
5	9/16	8/16	2
5	9/16	12/16	3
4 15/16	10/16	13/16	4
5	11/16	1	5
5	11/16	12/16	6

* After Frame 1, bubbles were removed from water-table surface which caused a 1/4" flow depth reduction

Figure E.1 Cascade Data Sample

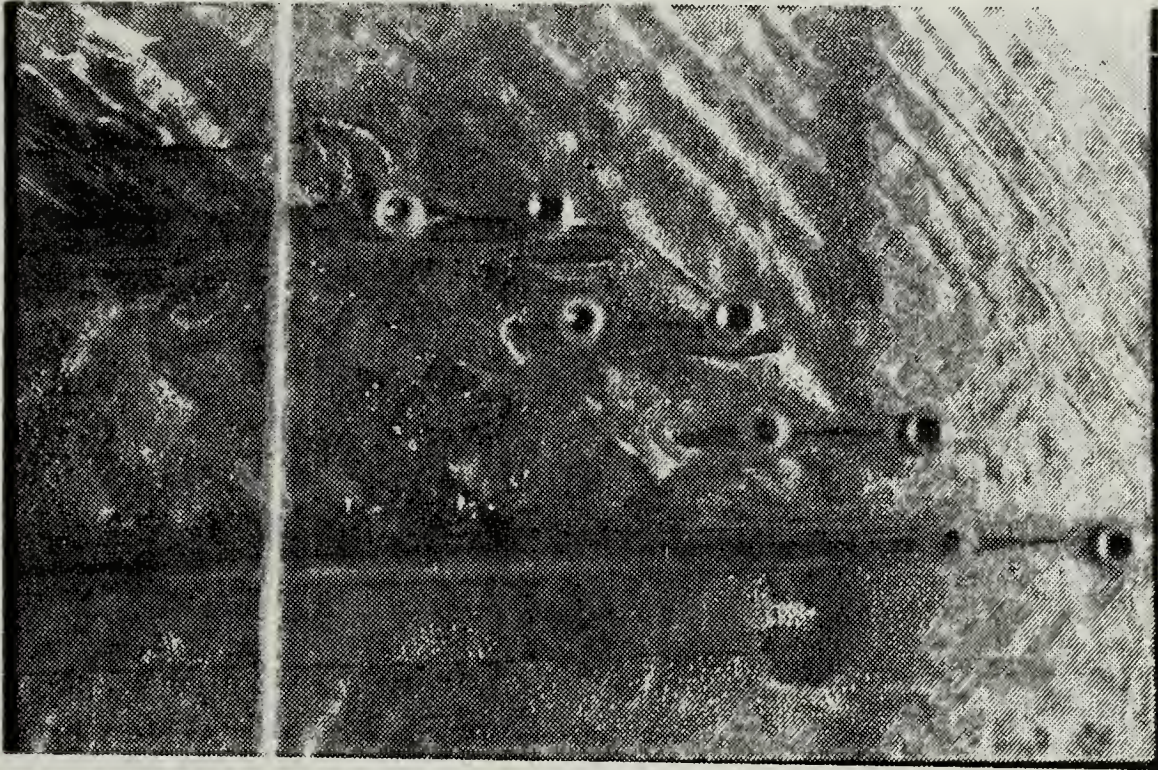

Figure E.2a Test Frame 1

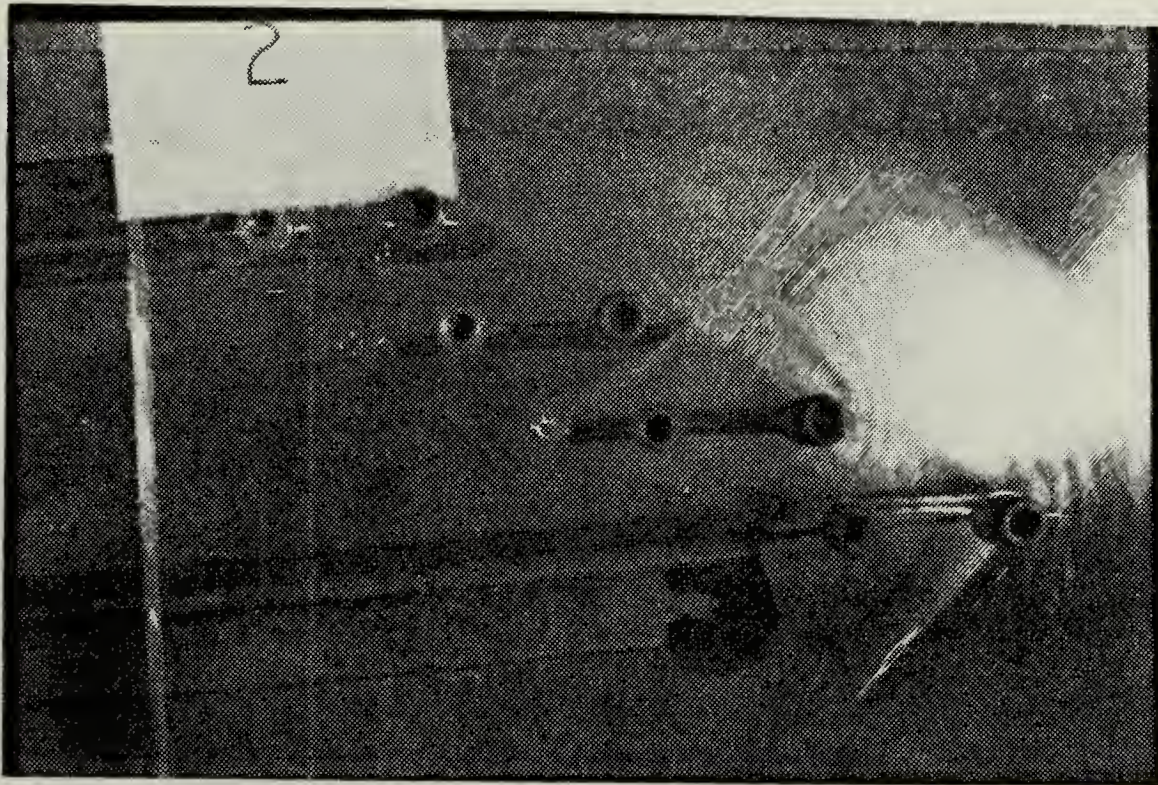

Figure E.2b Test Frame 2

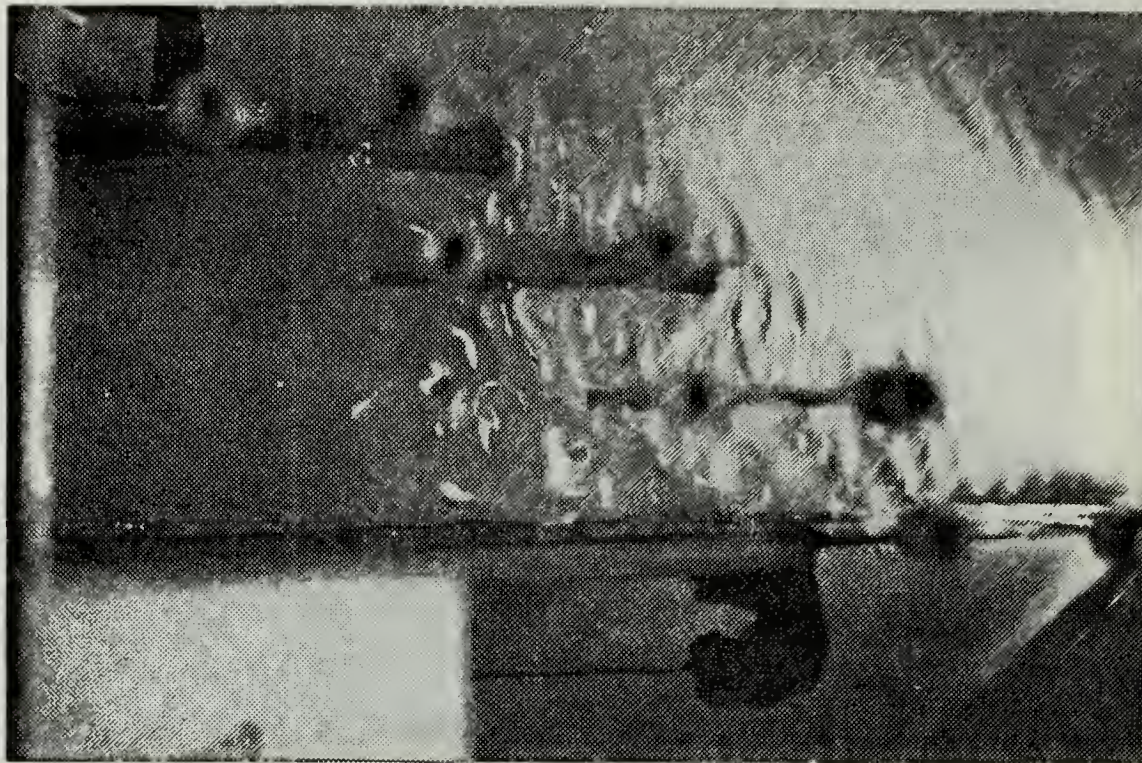

Figure E.2c Test Frame 3

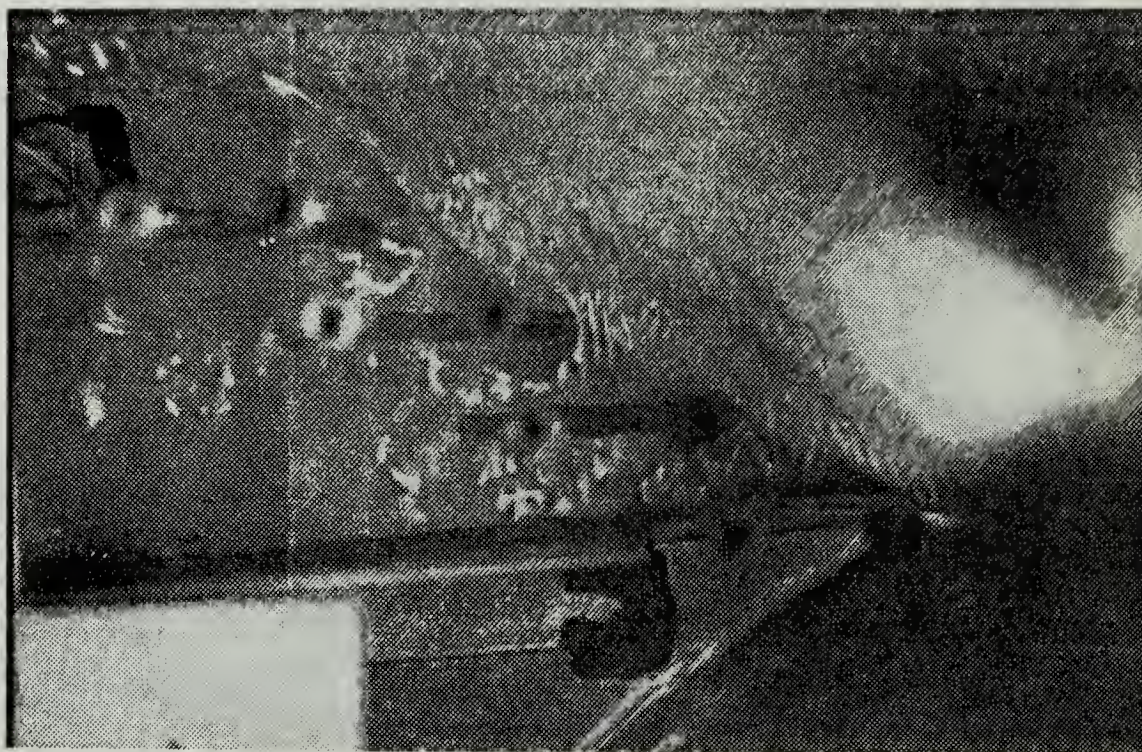

Figure E.2d Test Frame 4

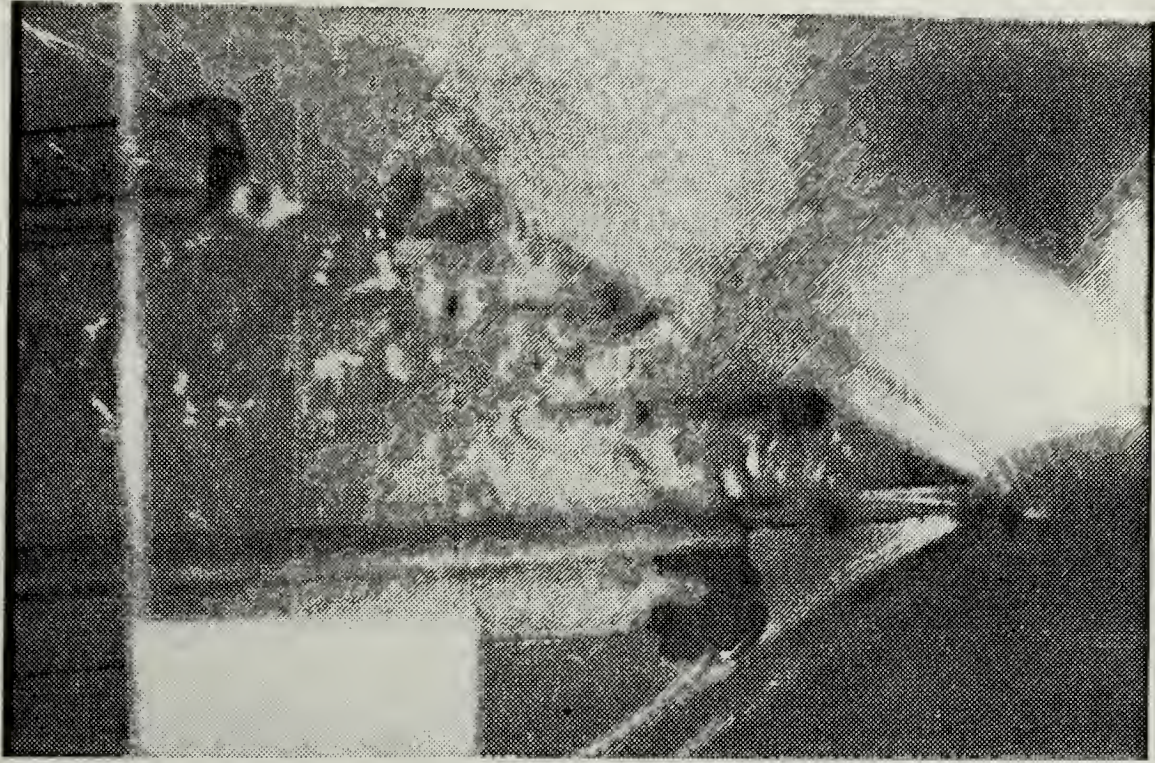

Figure E.2e Test Frame 5

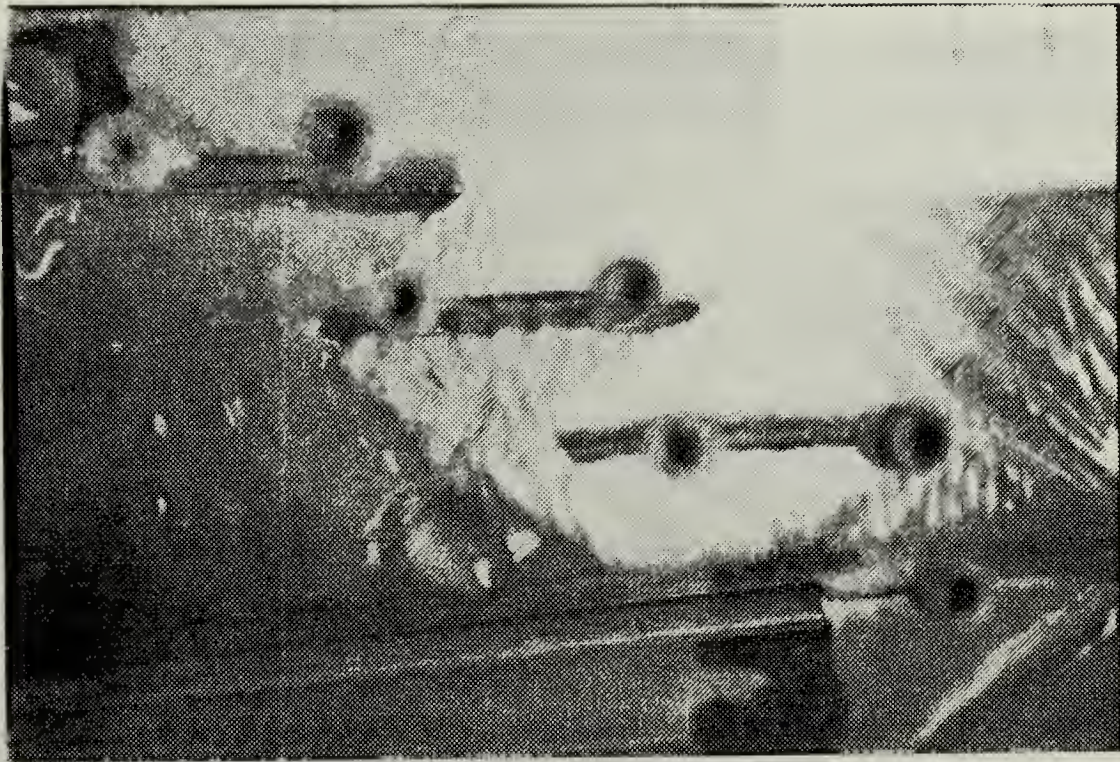
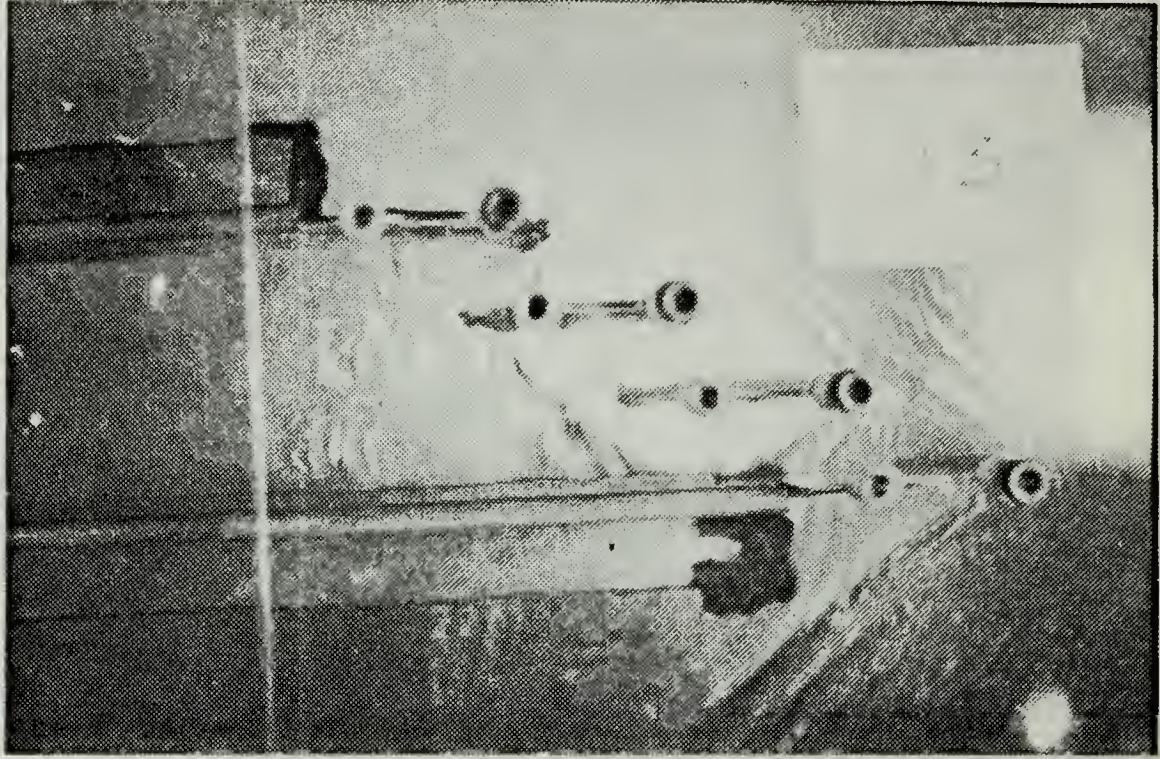
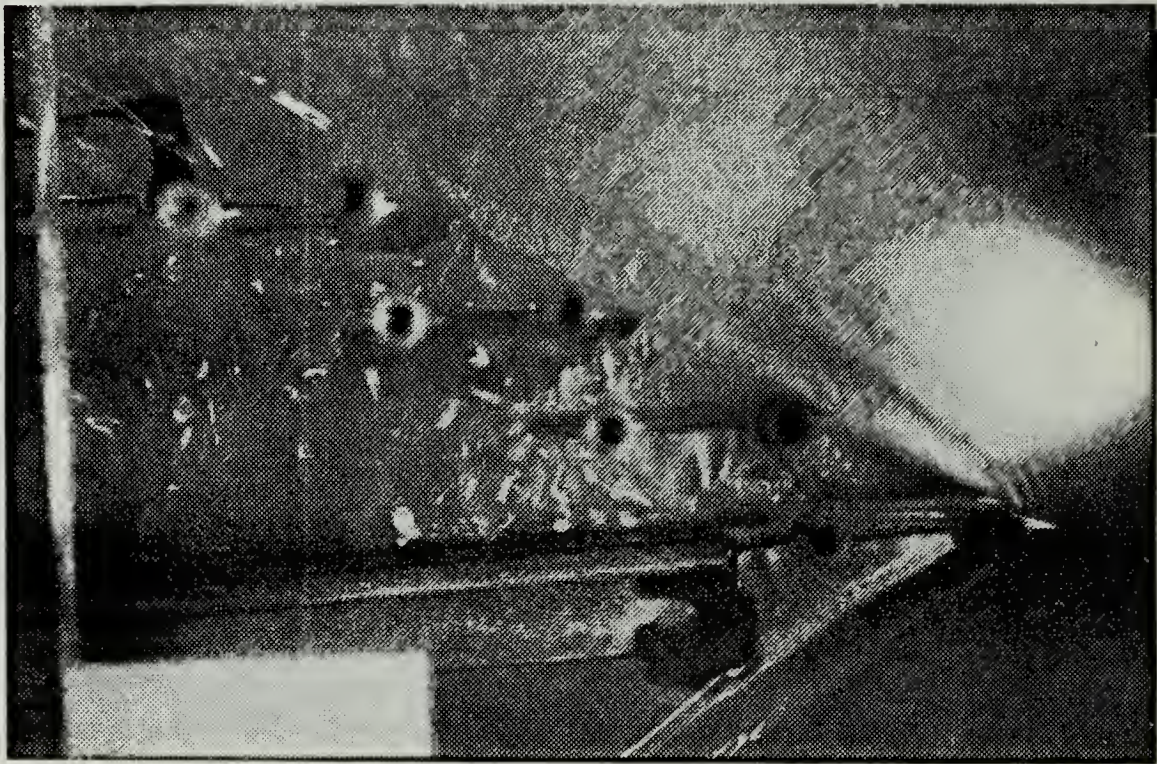

Figure E.2f Test Frame 6



$$i = +2.8^\circ \quad \Delta\beta = 6^\circ$$



$$i = +2.8^\circ \quad \Delta\beta = 6^\circ$$

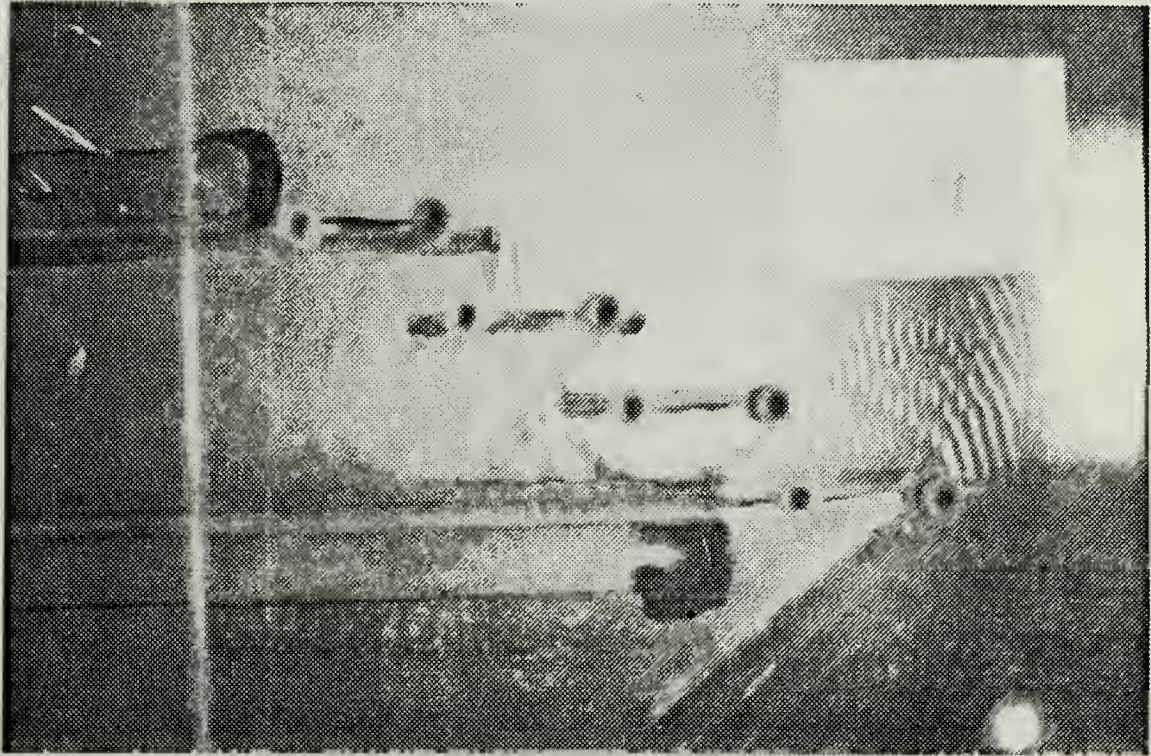

$$i = 0.9^\circ \quad \Delta\beta = 4^\circ$$

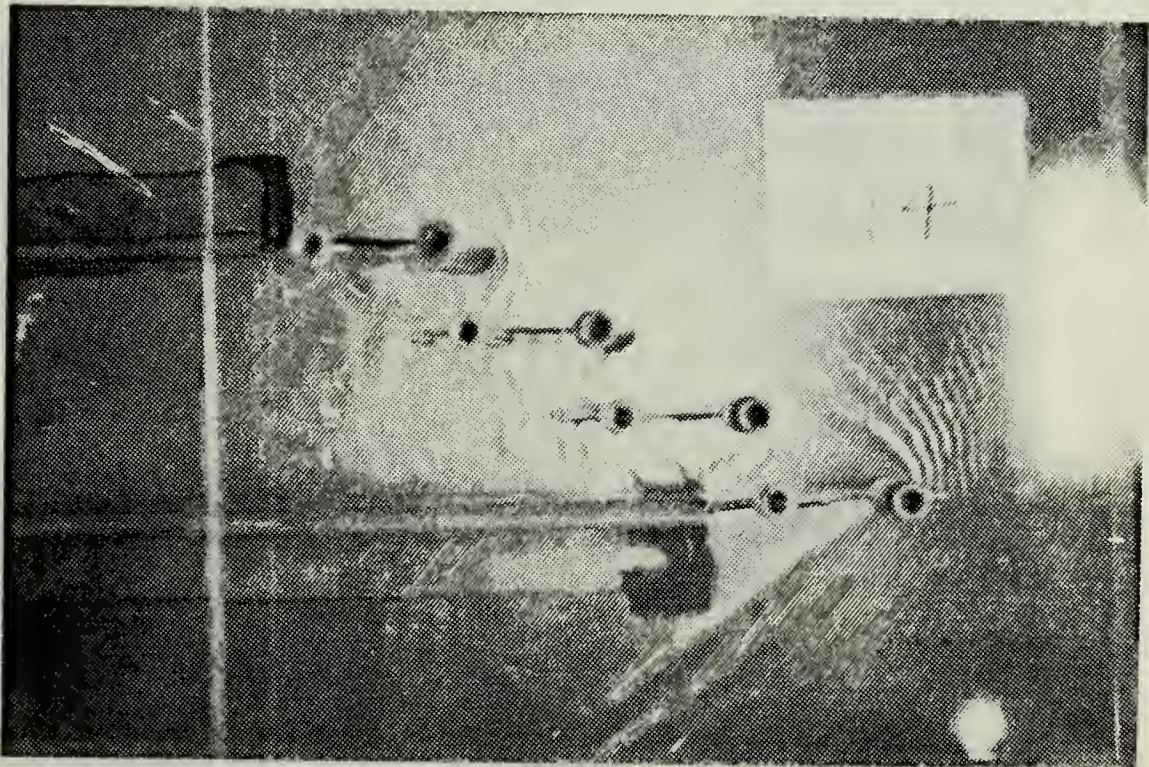

$$i = 0.9^\circ \quad \Delta\beta = 4^\circ$$

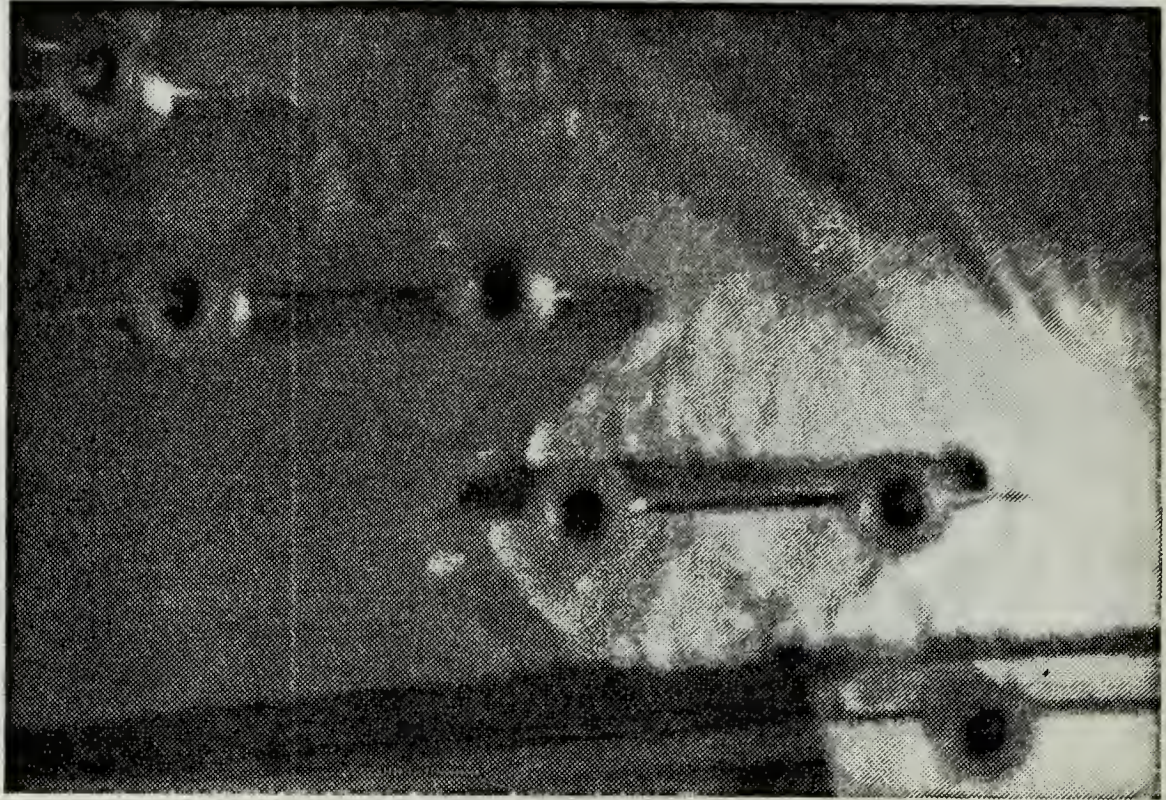

$$i = 0.9^\circ \quad \Delta\beta = 8^\circ$$

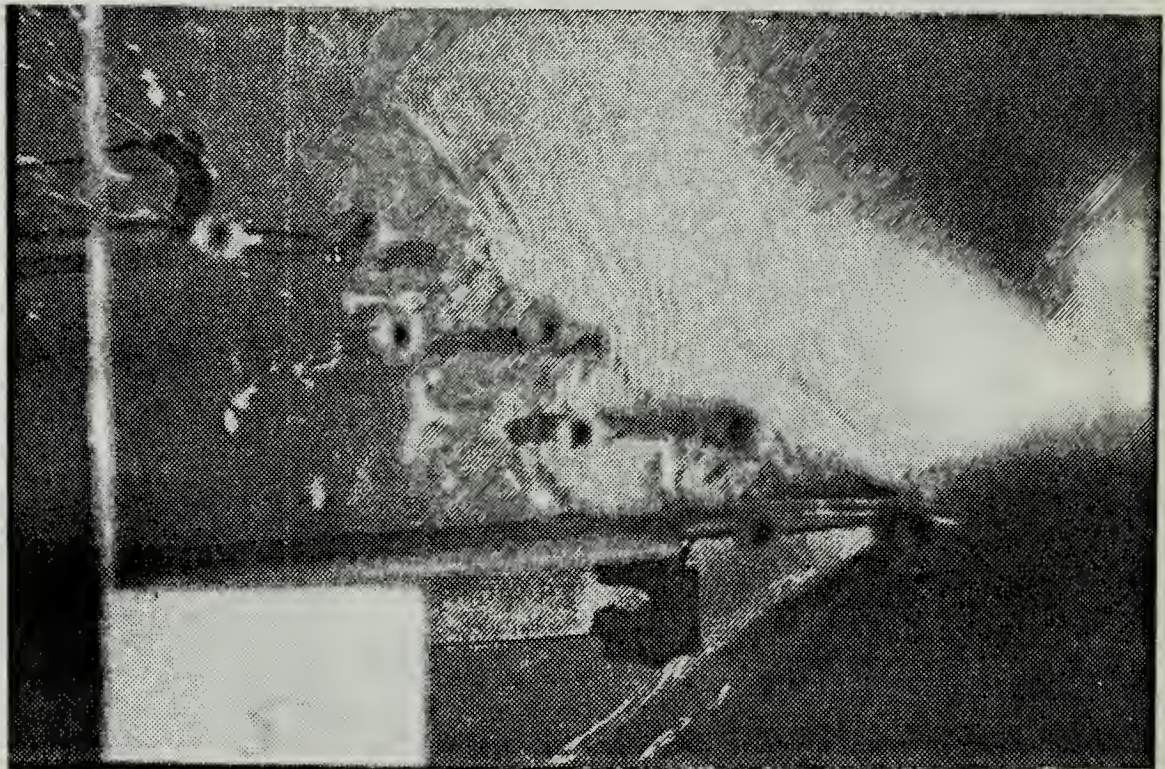

$$i = 0.9^\circ \quad \Delta\beta = 8^\circ$$

REFERENCES

1. Demo, W.J., Cascade Wind Tunnel for Transonic Compressor Blading Studies, Master's Thesis, Naval Postgraduate School, Monterey California, June 1978.
2. Erwin, J.R., Reviews of the Design of the NPS / TPL Transonic Compressor, Contractor Report NPS567-83-004CR, Naval Postgraduate School, Monterey, California, March 1983.
3. Hegland, M.G., Investigation of a Mach 1.4 Compressor Cascade with Variable Back Pressure Using Flow Visualization, Master's Thesis, Naval Postgraduate School Monterey California, March 1986.
4. Zucker, R.D., Fundamentals of Gas Dynamics, Matrix Inc., Beaverton, Oregon, 1977, pp. 176-188, 379.
5. Preiswerk, E., Application of the Methods of Gas Dynamics to Water Flows with Free Surface,
Part I, Flows with No Energy Dissipation, Naca TM No. 934, March 1940
Part II, Flows with Momentum Discontinuities (Hydraulic Jumps), Naca TM No. 935, March 1940.
6. Ippen A.T. and Harleman R.F., Verification of Theory for Oblique Standing Waves, American Society of Civil Engineers Transactions, Paper No. 2815, Volume No. 121, 1956.

BIBLIOGRAPHY

Albertson, M.L., Barton, J.R., and Simons, D.B., Fluid Mechanics for Engineers, Prentice-Hall, Inc. 1960.

Orlin, W.J., Linder, J.L., and Bitterly J.G., Application of the Analogy Between Water Flows with a Free Surface and Two-Dimensional Compressible Gas Flow, Naca TM No. 1185, February 1947.

Steinhilper, I.W., Seichtwasserkanal zur Simulierung von Gasströmungen im Geschwindigkeitsbereich $0.6 < Ma < 3.5$, Institut Fur Chemie Der Trieb-Und Explosistoffe, 31 December 1971.

INITIAL DISTRIBUTION LIST

	No. Copies
1. Defense Technical Information Center Cameron Station Alexandra, Virginia 22304-6145	2
2. Superintendent Attn: Library, Code 0142 Naval Postgraduate School Monterey, California 93943-5002	2
3. Department Chairman, Code 67 Department of Aeronautics Naval Postgraduate School Monterey, California 93940	1
4. Dr. R.P. Shreeve Director Turbo-Propulsion Laboratory Code 67 Naval Postgraduate School Monterey, California 93940	8
5. Lt. A.K. Byrd Fleet Air Keflavik Box 2 FPO NY. 09571-0202	4
6. Lt. Col. W.H. Byrd Director AFROTC Box 11186 Rock Hill, S.C. 29730	1

116
176087

MAY 1968		MAY 1968	
SUNDAY		SUNDAY	
MAY 1968		MAY 1968	
MAY 1968		MAY 1968	
1	2	3	4
5	6	7	8
9	10	11	12
13	14	15	16
17	18	19	20
21	22	23	24
25	26	27	28
29	30	31	

TITLE NUMBER: _____ CUSTOMER NUMBER: _____

LIBRARY: Dudley Knox Library, Naval Postgraduate School
 Monterey, Ca 93943

ROSWELL BOOKBINDING

LIBRARY DIVISION

2614 NORTH 29th AVENUE
 PHOENIX, ARIZONA 85009
 PHONE (602) 272-9338

Binding in Everything	<input checked="" type="checkbox"/>						
CONTENTS	<table border="1"><tr><td>F</td><td>B</td><td>NP</td></tr><tr><td></td><td></td><td></td></tr></table>	F	B	NP			
F	B	NP					
INDEX	<table border="1"><tr><td></td><td></td><td></td></tr><tr><td></td><td></td><td></td></tr></table>						
Bind without Index	<table border="1"><tr><td></td><td></td><td></td></tr></table>						
ISSUE CONTENTS							
Discard	<input type="checkbox"/>						
Bind in Place	<input type="checkbox"/>						
Gather at Front	<input type="checkbox"/>						
Advertisements	<table border="1"><tr><td>IN</td><td>OUT</td></tr><tr><td></td><td></td></tr></table>	IN	OUT				
IN	OUT						
Front Covers	<table border="1"><tr><td></td><td></td></tr><tr><td></td><td></td></tr></table>						
Back Covers	<table border="1"><tr><td></td><td></td></tr><tr><td></td><td></td></tr></table>						
1st only	<input type="checkbox"/>						
Accents	<input type="checkbox"/>						
Imprints	<input type="checkbox"/>						
Special Instructions							

ALAN K. BYRD

B9545

Thesis B9545

Buck Color	598
Print Color	Gold
Trim Height	
Ht Inches	
Over Thick	
For Title	
Extra Lines	
Extra Coll.	
Hand Sew	
Slit	
Rules	
1st Slot No	
Vol Slot No	
Year Slot No	
Call # Slot	
Imp Slot No	
Type Face	
Price	
Mending	
Map Pockets	
2 Vols in 1	

ACTUAL TRIM	DATE
SPINE	JOB
BOARD DIM	LOT
CLOTH DIM	ROUTE
CLOTH BIN	SEQ NO

116
 1765/7

DUDLEY KNOX LIBRARY
NAVAL POSTGRADUATE SCHOOL
MONTEREY, CALIFORNIA 93943-6002

220995

Thesis

B9545 Byrd

c.1 Transonic compressor
blade tip flow visuali-
zation on a water table.

220995

Thesis

B9545 Byrd

c.1 Transonic compressor
blade tip flow visuali-
zation on a water table.

thesB9545

Transonic compressor blade tip flow visu

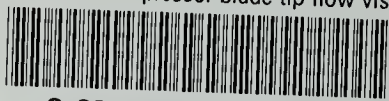

3 2768 000 75831 2

DUDLEY KNOX LIBRARY