



**Calhoun: The NPS Institutional Archive**  
**DSpace Repository**

---

Theses and Dissertations

1. Thesis and Dissertation Collection, all items

---

1993

Design considerations for remotely operated welding in space: task definition and visual weld monitoring experiment.

Renyerson, Charles Martin.

---

<https://hdl.handle.net/10945/24144>

---

*Downloaded from NPS Archive: Calhoun*



Calhoun is the Naval Postgraduate School's public access digital repository for research materials and institutional publications created by the NPS community. Calhoun is named for Professor of Mathematics Guy K. Calhoun, NPS's first appointed -- and published -- scholarly author.

**Dudley Knox Library / Naval Postgraduate School**  
**411 Dyer Road / 1 University Circle**  
**Monterey, California USA 93943**

<http://www.nps.edu/library>









DESIGN CONSIDERATIONS FOR REMOTELY OPERATED WELDING IN  
SPACE: TASK DEFINITION AND VISUAL WELD MONITORING EXPERIMENT

by

Charles Martin Reynerson

B.S. Naval Architecture, University of California, Berkeley (1987)

SUBMITTED TO THE DEPARTMENT OF OCEAN ENGINEERING AND THE  
DEPARTMENT OF AERONAUTICS AND ASTRONAUTICS IN PARTIAL  
FULFILLMENT OF THE REQUIREMENTS FOR THE DEGREES OF

ENGINEER IN AERONAUTICS AND ASTRONAUTICS

and

NAVAL ENGINEER

at the

MASSACHUSETTS INSTITUTE OF TECHNOLOGY

May, 1993

© Charles Martin Reynerson, 1993. All rights reserved

The author hereby grants to MIT permission to reproduce and to  
distribute copies of this thesis document in whole or in part.



DESIGN CONSIDERATIONS FOR REMOTELY OPERATED WELDING IN  
SPACE: TASK DEFINITION AND VISUAL WELD MONITORING EXPERIMENT

by

Charles Martin Reynerson

SUBMITTED TO THE DEPARTMENT OF OCEAN ENGINEERING AND THE  
DEPARTMENT OF AERONAUTICS AND ASTRONAUTICS IN PARTIAL  
FULFILLMENT OF THE REQUIREMENTS FOR THE DEGREES OF

ENGINEER IN AERONAUTICS AND ASTRONAUTICS

AND

NAVAL ENGINEER

**Abstract**

This thesis explores the concept of welding in a space environment with the use of automation. Since the amount of time astronauts can work outside a spacecraft is limited, future construction and repair tasks will likely be assisted by automation. It is also likely that remote space welding will be needed for the construction of large-scale space structures in earth orbit as well as for lunar and martian ground-based structures. Due to the complex nature of the tasks to be accomplished, the equipment will probably not be fully autonomous but instead supervised by a human operator.

The welding fabrication problem in space is examined in a broad sense, including some of the considerations for designing a human supervisory remote welding system. The history of space welding processes is examined, as well as current research in the field. A task definition and functional analysis is provided to assist future designers in outlining typical operational sequences for such a remote welding system. Such analysis is important when deciding whether the human operator should perform certain tasks or if the operator should supervise the automated system while it performs the tasks.

An experiment was performed to test the ability of a remote operator to recognize surface weld defects using a video image from a CCTV camera located at the inspection site. Variables studied include camera field of view, lighting conditions, and video viewing vs. direct viewing. Several defect types were used to determine how the variables affected recognition success rates.

Thesis Supervisor: Koichi Masubuchi  
Professor of Ocean Engineering and Material Science





## **Acknowledgements**

I would like to thank my thesis advisor, Koichi Masubuchi, for the constant guidance and support he has offered me since the first time I set foot in his office. Without him, I may not have been able to achieve MIT's first dual engineer degrees in NE and EAA. I also thank him for sending me to Huntsville, Alabama for a week-long workshop entitled "Space Welding", held in August 1992. I also wish to thank my thesis reader, Greg Zacharias, for agreeing to this duty when my original thesis reader elected to leave MIT. His help and inspiration was invaluable during the experimental portion of this thesis.

I would also like to thank my wife, Valerie, for her patient support during the writing of this thesis. Her editorial skills helped tremendously to transform my worst sentences into something more concise. As the first experimental subject to view the videotape, her suggestions helped to make the other viewing sessions go more smoothly.

I give special thanks to the other experimental subjects: Gokhan Gotug, Pat Keenan, Shinji Koga, Koichi Masubuchi, and Jeff McGlothlin.



## Table of Contents

Abstract .....	2
Acknowledgements .....	3
Table of Contents .....	4
List of Figures and Tables .....	9
List of Acronyms and Abbreviations .....	14
Chapter 1: Thesis Overview .....	15
Chapter 2: Background .....	18
2.1 Current Space Programs .....	18
2.1.1 Space Station Freedom .....	18
2.1.2 Space Exploration Initiative .....	25
Chapter 3: Introduction .....	28
3.1 A Short History of Welding in Space .....	29



3.2	Other Forms of Remote Welding . . . . .	33
3.2.1	Underwater Welding . . . . .	34
3.2.2	Welding Inside Nuclear Reactor Vessels . . . . .	35
3.2.3	Space Limited High-Rise Construction . . . . .	36
3.3	Automating Space Welding . . . . .	37
3.3.1	The "Instamatic" Welding Concept . . . . .	37
3.3.2	Automated Welding Experiments in Space . . . . .	39
3.3.3	Welding Planned for Space Station Freedom . . . . .	40
3.3.4	Using Telerobotics for Space Welding . . . . .	43
Chapter 4: Defining the Welding Fabrication Problem . . . . .		45
4.1	Advantages of Welding . . . . .	49
4.2	Requirements for Welding in the Space Environment . . . . .	51
4.2.1	Some Lessons Learned from the USSR Space Program . . . . .	56
4.3	Possible Applications of Welding in Space . . . . .	60
4.3.1	Construction . . . . .	62
4.3.1.1	On-Orbit Structures . . . . .	62
4.3.1.2	Structures on the Moon and Mars . . . . .	68
4.3.2	Repair and Maintenance . . . . .	71
4.4	Joint and Surface Preparation . . . . .	74
4.5	Welding Processes . . . . .	80



4.6	Weld Quality Evaluation	99
4.6.1	Non-Destructive Tests	100
4.6.1.1	Visual Inspection	102
4.6.2	Quality Through Automation	103
4.7	Influence of Welding on Space Structural Design	104
Chapter 5:	The Use of Automation for Space Welding	108
5.1	Levels of Automated Control	109
5.2	Operational Control Modes for Space Welding	114
5.3	The Use of Robotic Manipulators in Space	120
5.4	Welding Sensors	127
5.4.1	Video Monitoring Sensors	127
5.4.2	Joint Tracking	130
5.4.2.1	Vision Based Joint Tracking Systems	131
5.4.3	Thermographic Sensing	137
5.4.4	Radiographic Sensing	137
5.5.1	Expert and Knowledge-based Systems	139
5.6	Human Operator Interface	143
Chapter 6:	Welding Fabrication Task Definition and Analysis	148
6.1	Work System Analysis	148
6.1.1	Work Objects	148





6.1.2	Equipment	151
6.1.3	Work Environment	153
6.2	Task Analysis	154
6.2.1	System Functional Analysis	154
6.2.2	Operational Sequence Analysis	156
6.3	Task Allocation	161
Chapter 7:	Experiment: Remote Viewing of Weld Defects	170
7.1	Experimental Objectives	170
7.2	Equipment and Weld Defect Samples	173
7.2.1	Experimental Equipment	173
7.2.2	Weld Defect Samples	177
7.3	Experimental Procedure	179
7.3.1	Videotape Production	180
7.3.2	Videotape Viewing	187
7.3.3	Direct Viewing	190
7.4	Experimental Results	191
7.4.1	Viewing Distance	197
7.4.2	Lighting Conditions	200
7.4.3	Direct Viewing Compared to Video Viewing	202
Chapter 8:	Conclusions	207



Appendix I:

Weld Sample Descriptions and Relationship Between Existing Acceptance

Standards . . . . . 210

Appendix II:

Summary Data Sheets for Experimental Subjects . . . . . 223

Appendix III:

Student's t Test Distribution Calculations and Confidence Levels . . . . . 234

Bibliography . . . . . 237



## List of Figures and Tables

### Chapter 2

Figure 2.1a	Space Station Freedom: configuration shown at Man-Tended Capability (MTC) [13]	21
Figure 2.1b	Space Station Freedom: configuration shown at Permanent Manned Capability (PMC) [13]	21
Table 2.1	Space Station Freedom configuration capabilities [13]	23
Table 2.2	Specifications of Space Station Freedom at PMC [13]	24
Figure 2.2	The Space Exploration Initiative [12]	27

### Chapter 3

Figure 3.1	Vulcan welding unit [28]	30
Figure 3.2	Versatile EB hand tool system (URI) [28]	31
Figure 3.3	Versatile work tool [28]	31
Figure 3.4	Some joint types for instamatic welding systems [57]	38

### Chapter 4

Figure 4.1	Pore formation in welds by EBW of AMg-6 alloy [48]	59
Figure 4.2	EB cutting in zero gravity a) with and b) without controlled cooling of one side of the cut [48]	59
Figure 4.3	Prototype of hand-held EB gun	61
Figure 4.4	Unit for transformable truss unfolding/folding [23]	63



Figure 4.5	Prototype joint for use in space - MIT connector design [57]	65
Figure 4.6	Possible permanent fastening of the MIT connector [57]	66
Figure 4.7	Top and side view of the MMRC aerobrake design [8]	69
Figure 4.8	Three typical methods for placing a patch plate over a damaged structural member of a space station [57]	73
Figure 4.9	ACCESS experiment's assemble fixture [33]	77
Figure 4.10	EVA and telerobotic cooperation during aerobrake assembly testing in neutral buoyancy [8]	79
Figure 4.11	Hot hollow cathode welding scheme [66]	85
Figure 4.12	Prototype of torch and power supply for manual hollow cathode welding in space [66]	86
Figure 4.13	Electron beam welding processes [48]	91
Figure 4.14	Energy effectiveness comparison between EBW, GMAW, and PAW [48]	92
Figure 4.15	Eight basic types of welds [26]	105
Figure 4.16	Fillet weld used to make the five basic joints [26]	106

Chapter 5

Figure 5.1	Basic concept for remote human-supervised control system [76]	110
Figure 5.2	The spectrum of control modes [76]	112
Figure 5.3	Levels of control for GMAW [26]	113





Figure 5.4	Space-ground communication link for Space Station Freedom	
	[75] .....	117
Figure 5.5	Diagram of teleoperator system using a predictor display	
	[76] .....	118
Figure 5.6	Photograph of stick figure superimposed on a video screen	
	[76] .....	119
Figure 5.7	Design proposed for NASA flight telerobotic servicer (FTS)	
	[59] .....	123
Figure 5.8	Special purpose dexterous manipulator (SPDM) configuration	
	[75] .....	125
Figure 5.9	Mobile servicing center and SPDM [13] .....	126
Figure 5.10	SPDM at end of the SSRMS [75] .....	128
Figure 5.11	Some joint and weld types trackable by vision systems	
	[17] .....	132
Figure 5.12	Adaptive robotic welding system architecture [2] .....	134
Figure 5.13	The principle of structured lighting for weld bead and joint	
	inspection [1] .....	135
Figure 5.14	Pair of typical weld joints, the corresponding sensor images, and	
	the analysis results [17] .....	136
Figure 5.15	Schematic view of a linear array fiber-optic thermographic sensor	
	[21] .....	138
Figure 5.16	Schematic of vertical setup for the observation of real-time	



radiography [70] . . . . .	140
Figure 5.17 Expert system consultation session results [43] . . . . .	142
Figure 5.18 Operator interface display including menu bar, annunciators, status window, and weld parameters window [68] . . . . .	145
Figure 5.19 Task allocation: extreme effects of supervisory underwork and overwork [76] . . . . .	147

Chapter 6

Figure 6.1 Automated arc welding system diagram [26] . . . . .	152
Table 6.1 Task Allocation Summary . . . . .	169

Chapter 7

Figure 7.1 Lighting conditions for experiment . . . . .	172
Table 7.1 Equipment list and specifications . . . . .	174
Figure 7.2 Equipment layout and connections . . . . .	175
Figure 7.3 Photograph of monitor, camera power supply, VCR, and video printer . . . . .	176
Figure 7.4 Photograph of fillet weld sample at camera distance of 40" . .	182
Figure 7.5 Photograph of fillet weld sample at camera distance of 30" . .	182
Figure 7.6 Photograph of fillet weld sample at camera distance of 20" . .	183
Figure 7.7 Photograph of fillet weld sample at camera distance of 10" . .	183
Figure 7.8 Photograph of excessive re-entrant angle defect with lighting from	



above .....	184
Figure 7.9 Photograph of excessive re-entrant angle defect with lighting from the side .....	184
Figure 7.10 Photograph of undercut defect with lighting from above ...	185
Figure 7.11 Photograph of undercut defect with lighting from the side ..	185
Table 7.2 Order of conditional viewing arranged on video tape .....	186
Exhibit 7.1 Subject instructions and data sheets .....	188
Table 7.3 Data summary for experiment .....	192
Table 7.4 Summary of confidence levels for video viewing .....	195
Table 7.5 Summary of confidence levels for video viewing by defect type .....	196
Figure 7.12 Effect of distance on the percent of defects correctly identified .....	198
Figure 7.13 Effect of distance on the percent of defects correctly identified by defect type .....	199
Figure 7.14 Effect of lighting conditions on the percent of defects correctly identified .....	201
Figure 7.15 Effect of lighting conditions on the percent of defects correctly identified by defect type .....	203
Figure 7.16 Comparison of direct viewing vs. video viewing .....	204
Table 7.6 Summary of confidence levels comparing video viewing with direct viewing .....	205



## List of Acronyms and Abbreviations

ACCESS	Assembly Concept for Construction of Erectable Space Structures
CCTV	Closed-circuit television
EASE	Experimental Assembly of Structures in EVA
EB	Electron beam
EBW	Electron beam welding
ECLSS	Environmental Control and Life Support System
EDM	Electrostatic discharge machining
ET	External tank
EVA	Extra-vehicular activity
FTS	Flight Telerobotic Servicer
GMAW	Gas metal arc welding
GTAW	Gas tungsten arc welding
LEO	Low-earth orbit
NDT	Non-destructive test
NASA	National Aeronautics and Space Administration
NSRP	National Shipbuilding Research Program
OMV	Orbital Maneuvering Vehicle
SEI	Space Exploration Initiative
SSF	Space Station Freedom





## Chapter 1: Thesis Overview

This thesis will examine several design considerations associated with automated welding fabrication in remote locations. Although this thesis primarily focuses on welding in space, many of the same concepts can be extended to welding underwater, in high radiation areas, and in other environments considered hostile to humans.

In order to encompass the scope of this problem, the first portion of this thesis examines welding in the remote environment of space, defines the welding fabrication problem, and introduces the use of automation for welding in space. These three subjects are discussed in Chapters 3, 4, and 5 respectively. Chapter 3 introduces the history of welding in space, examines similar forms of remote welding, and gives several examples of how automated welding may be used in space. Chapter 4 defines the welding fabrication problem in space. Welding fabrication is not limited to the welding process itself, but also includes pre-weld joint preparation and post-weld inspection and evaluation. Chapter 5 examines the use of automation for space welding. The automation of welding in space is likely to combine several technologies, possibly those used in space manipulators and industrial welding robots. Computerized control schemes based on intelligent machine control and



knowledge-based systems may be required to replace or supplement the human skills ordinarily needed for welding.

One goal of this thesis is to help define the probable tasks needed for space welding fabrication and to determine which of the tasks can be best performed using either manual control, supervisory control, or fully automated control. Chapter 6 addresses task definition and analysis for space welding fabrication. By examining the details of the process through task analysis, conclusions and recommendations are made for the design of space welding fabrication systems.

A visual weld monitoring experiment was performed to test the ability of a remote operator to recognize weld defects by observing a video image from a CCTV camera. The use of CCTV cameras is an inexpensive, yet effective way for a remote operator to ensure the finished weld is free from major surface defects. Inspections are not only important immediately after the welding is complete, but also as routine periodic maintenance checks, to help isolate and correct defects that may develop over the life of the structure.

Experiment subjects were used to simulate a remote operator whose job it is to view welded joints and identify the presence of defects and evaluate the type of defect. The subjects viewed several weld specimens on a pre-recorded video tape. The viewing conditions were changed by varying the camera distance from the weld, and the direction of the lighting. The subjects were then asked to physically hold and examine the specimens. The results were



studied to determine if changing the viewing conditions would affect defect recognition. The video viewing portion of the experiment was compared to the direct viewing portion to evaluate the utility of using remote cameras to perform weld inspections. Chapter 7 describes the experimental equipment, procedure, and results.

Conclusions derived from the experiments are summarized in the final chapter.



## **Chapter 2: Background**

### **2.1 Current Space Programs**

#### **2.1.1 Space Station Freedom**

A Space Station Task Force was formed by The National Aeronautics and Space Administration (NASA) in 1982 to conceive a permanently manned station to be constructed in low Earth orbit (LEO). In a speech conducted on January 5, 1984, President Ronald Reagan committed the nation to develop a permanently manned Space Station and to do it within a decade. Later, Canada, the European Space Agency (ESA), and Japan agreed to become partners. On July 18, 1988, President Reagan named the international Space Station "Freedom."

NASA's space station is the next logical step for advancing the human exploration of space. Space exploration requires a permanently manned space station in order to study human adaption, testing of life support systems, and to gain experience in the construction, maintenance, and operation of a large manned space system. The station will also be used as an Earth-orbiting laboratory for research in the microgravity environment of space for extended





periods of time.

The program objectives for the Space Station are as follows:

- Establish a permanently manned, multipurpose facility in LEO in the 1990s;
- Enhance and evolve mankind's ability to live and work safely in space;
- Stimulate technologies of national importance by using them to provide Space Station Freedom capabilities;
- Provide long-term, cost-effective operation and utilization of continually improving facilities for scientific, technological, commercial, and operational activities enabled or enhanced by the presence of man in space;
- Promote substantial international cooperation in space;
- Create and expand opportunities for private-sector activity in space;
- Provide for the evolution of Space Station Freedom to meet future needs and challenges;



- Foster public knowledge and understanding of the role of habitable space system capabilities in the evolution of human experience outside Earth's atmosphere. [13]

Current plans show that the station should be completed by the year 2000. The first element launch is scheduled for the first quarter of 1996 using the space shuttle. After five more assembly flights, the station will have Man-Tended Capability (MTC) with the arrival of the first of four pressurized modules. At the MTC stage, the station will allow for experiments to be conducted and remain unattended between assembly flights. After eleven more assembly flights the station will reach the Permanently Manned Capability (PMC) stage in which the station can become permanently manned with an emergency escape capability. Figures 2.1a and 2.1b show the configuration of the station at MTC and PMC respectively. The four primary modules that includes the crew Habitation Module, the U. S. Laboratory Module, the Japanese Experiment Module (JEM), and the ESA Module, Columbus, are situated in the center of the station. These primary modules are connected to each other by using two slightly smaller Resource Node structures. The Resource Nodes are a center for command, control and operations, and they are used as a docking point for the space shuttle. A hexagonal truss frame runs along the axis of the station, providing a backbone for the connection of all other system modules. Among the most prominent modules are the three



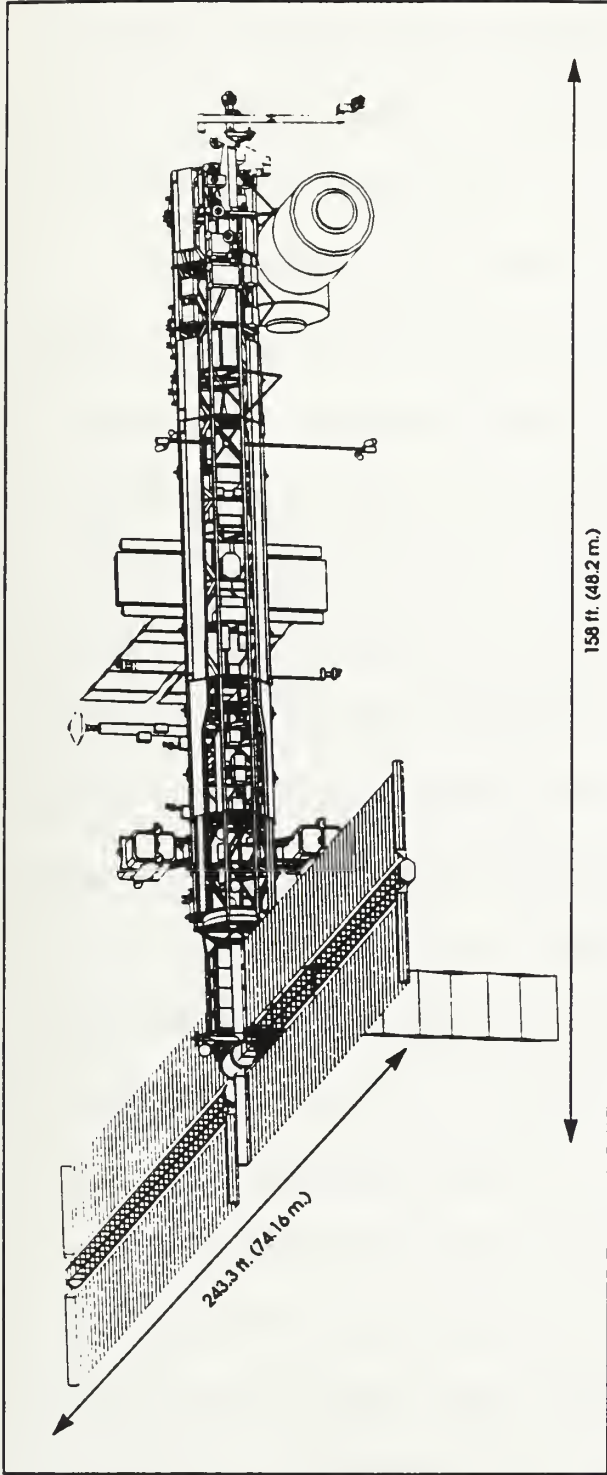

Figure 2.1a Space Station Freedom: configuration shown at Man-Tended Capability (MTC) [13]

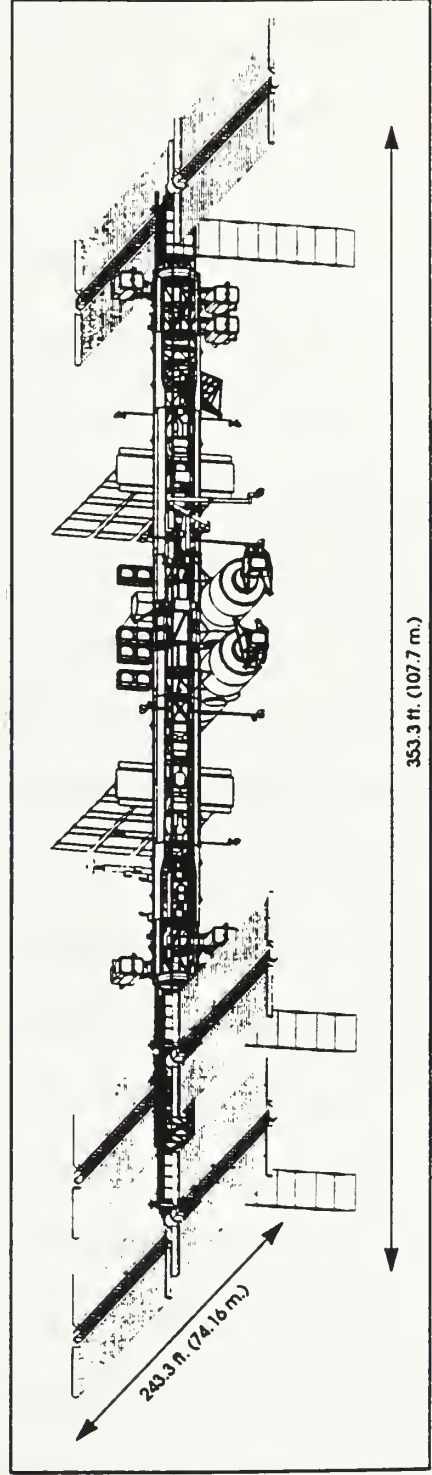

Figure 2.1b Space Station Freedom: configuration shown at Permanent Manned Capability (PMC) [13]



photovoltaic array (PV) modules, which supply solar power to the station. A fourth PV module is planned to be added after PMC to extend the power capability to 75 kW. Table 2.1 displays the configuration capabilities for both the MTC and PMC stages. Table 2.2 gives the general physical specifications of the station at the PMC stage.

Once the station has reached MTC, research can begin on board the station. Freedom will be an unprecedented facility for first-class basic and applied research dedicated towards expansion of scientific knowledge, improvement of the quality of life on Earth, and the national goal of world leadership in space exploration. Current areas of research are planned in the following areas: life sciences; microgravity materials, fluids, combustion and biotechnology; technology development. These are by no means the only areas of research since no one can predict the exciting knowledge and benefits that will be realized in the next 30 years.

At the 1992 Space Station Freedom Utilization Conference conducted in Huntsville, Alabama, NASA offered researchers from academia and commercial industry the opportunity to conduct their research on board the space station. The research to be conducted will be selected on the basis of technical merit, compatibility with NASA's program objectives, and the availability of space station resources. Such opportunities open the door for on-orbit research in the area of automated space welding. Although welding in space is not currently mission critical for the space station, to effectively achieve the goal of space





# Configuration Capabilities

## Man Tended Capability 1997      Permanently Manned Capability 2000

Power	18.75 kW - 1 PV module	56.25 kW - 3 PV modules
Module length	27 ft. - 1 microgravity lab	27 ft. - 1 lab, 1 hab
U.S. lab user racks (ISPRs)	12	12
User research power	11 kW	30 kW
Logistic module capacity	MPLM - 8 racks	PLM - 20 racks
Command uplink	70 kbps	70 kbps
Data downlink	43 Mbps	43 Mbps
Gravity level	1µg	1 µg
Attached payload accommodations	2 ports	4 ports
U.S. assembly and logistics flights	6	17
Permanent crew size	0	4 expandable to 8
Dedicated crew for research	4 (while on station)	2 (continuous)
Utilization flights (MTC to PMC)	8	N/A
Truss	4 segments built and checked out on ground	7 segments built and checked out on ground
Length (total)	158 ft.	353
Pressurized resource nodes	1	2
International hardware:	Canada	Mobile Servicing System
	Japan	JEM - 10 ISPRs
	Europe	APM - 20 ISPRs
Life Support	Shuttle supported	regenerative water loop
Propulsion	2 downstized modules	4 modules
Pressurized docking adapter	1	2
Airlock	0	1
Assured Crew Return Vehicle	0 - use Shuttle	1

Table 2.1 Space Station Freedom configuration capabilities [13]



## Specifications of Space Station Freedom (PMC)<sup>1</sup>

Element	Shape	Length (ft/m)	Width/Diameter (ft/m)	Weight (Tons/Kg)
Truss Assembly & Equipment	Hexagon	216.0 / 65.9	12 x 16 / 3.7 x 4.9	160.6 / 146,000
U.S. Laboratory Module	Cylinder	27.4 / 8.4	14.5 / 4.4	17.1 / 15,545
Habitation Module	Cylinder	27.4 / 8.4	14.5 / 4.4	17.8 / 16,182
Columbus APM	Cylinder	38.7 / 11.8	14.7 / 4.5	18.7 / 17,000
Japanese Module <sup>2</sup>	Cylinder	56.0 / 17.0	13.8 / 4.2	36.1 / 32,818
Resource Node <sup>3</sup>	Cylinder	17.0 / 5.2	14.5 / 4.4	25.9 / 23,545
Solar Panels <sup>4</sup>	Rectangle	112.0 / 34.0	39.0 / 11.9	8.7 / 7,909
Other (airlock; pressurized docking adapters)				24.7 / 22,431
Approx. Total Weight and Length of Station		353.0 / 107.6		309.6 / 281,430
Columbus Free-Flyer	Cylinder	39.4 / 12.0	14.7 / 4.5	20.1 / 18,200

<sup>1</sup> All specifications are approximate and subject to change and generally include user allocations.

<sup>2</sup> Includes Exposed Facility and Experiment Logistics Module.

<sup>3</sup> Dimensions are for one resource node; weight is total of two resource nodes and cupola.

<sup>4</sup> Shape and dimensions are for the Solar Array Wings; weight includes six of the Array Wings but not the truss.

Table 2.2 Specifications of Space Station Freedom at PMC [13]



exploration, welding in the environment of space will need consideration.

At the time of this writing, there has been a push by President Clinton's administration to take an additional look at redesigning the space station. Therefore, the configuration of the space station and its scheduled completion date as described above is likely to change. [82]

### **2.1.2 Space Exploration Initiative**

On July 20, 1989, the 20th anniversary of the first manned landing on the Moon, President George Bush put forth a challenge and a long-term goal for the US space program: "...First, for the coming decade - for the 1990's - Space Station Freedom, our critical next step in all our future endeavors. And for the next century, back to the Moon. Back to the future. And this time, back to stay. And then, a journey into tomorrow, a journey to another planet, a manned mission to Mars." [64] It was this visionary commitment that launched the Space Exploration Initiative (SEI). In the Augustine Report, written in December, 1990, the commitment to explore the vast frontier of space was further recommended and cited as one of the two long-term goals of the space program. The Stafford Synthesis Group Report of May 1991 then outlined a plan and options for achieving the goals of the SEI.

After the space station is completed, space exploration begins with a



human-tended base on the Moon and is followed by the human exploration of Mars. Figure 2.2 shows a rough timeline of the plan for future space activities. The establishment of a lunar outpost and the construction of a permanent base is expected to commence by 2001. The first human exploration of Mars is expected to be launched by 2011, followed by construction of a permanent base. Unfortunately, at the time of this writing, President Clinton's new administration has shown little interest in investing heavily in exploration. [82] Therefore, it is unlikely that the ambitious timeline of the SEI as shown in figure 2.2 will be accomplished.

It is difficult to imagine the construction of extraterrestrial bases without joining metal through welding. The space station was designed to not need any welding in orbit. Pressurized modules are constructed on Earth prior to launch and connected to the rest of the station mechanically. The design of the modules is limited by the physical dimensions of the space shuttle's payload bay. If larger pressurized chambers are required for an outpost, either the size of the launch vehicle must be larger, or an alternative form of construction, such as welding in space, will be needed. Further advantages of welding in space are addressed in later chapters.





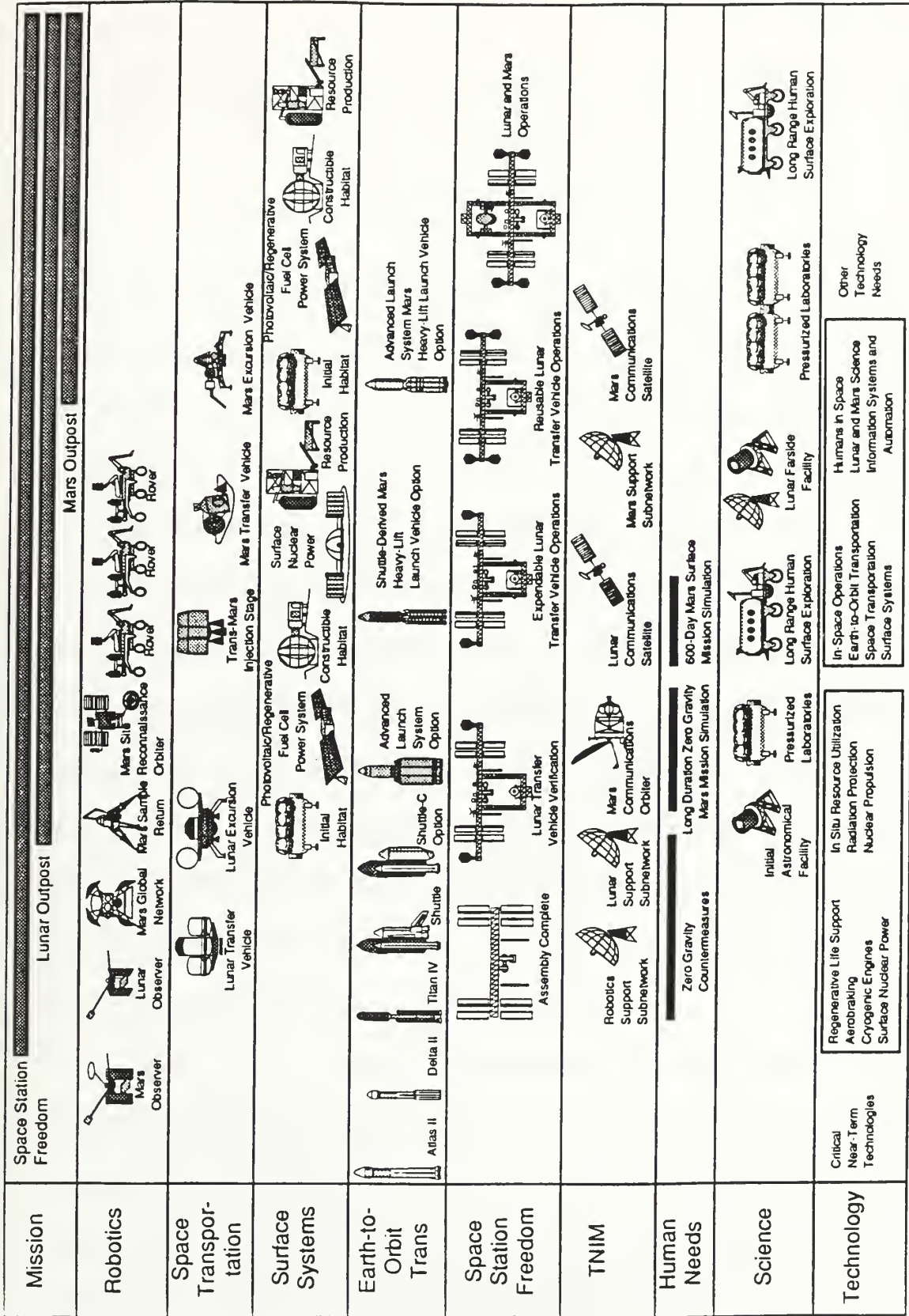

Figure 2.2 The Space Exploration Initiative [12]



## Chapter 3: Introduction

Although current plans for the Space Station Freedom call for mechanically connected joints, welding does have its place in space fabrication. There is bound to be accidental damage, ranging from meteor showers to structural failure, that can best be repaired using welding techniques. But what is the best way to apply these techniques? For a repair job that may be needed in rare circumstances, an astronaut might be able to perform the task adequately with a hand-held welding device. But can an astronaut perform a reliable welding job with little or no experience? The constraints of a bulky extra-vehicular activity (EVA) suit could make it difficult to perform good welding, if not make it impossible. Welding while wearing an EVA suit is not one of the safest tasks an astronaut might want to perform due to the chance of damaging the suit. EVA in itself is a more hazardous evolution than most other tasks that could be performed within a spacecraft.

Robotics may be a solution to such problems. Telerobotics in particular can allow an astronaut or even welding experts on Earth to perform tasks that are difficult or impossible using EVA alone. It is unlikely that fully autonomous robotic systems will be developed for space construction efforts until telerobotic supervisory systems have proven their reliability and utility.



### 3.1 A Short History of Welding in Space

The first welding experiment conducted in space was performed by the USSR in 1969. They used automatic welding equipment called "Vulcan" to show that melting, welding, and cutting using an electron beam was stable and the conditions in space were adequate for good weld formation and cutting. The Vulcan welding unit is shown in Figure 3.1. From 1970 to 1974, scientists in the USSR studied welding methods, materials, and metallurgical processes in flying laboratories and thermal vacuum chambers. Compared to other welding methods, they selected electron beam (EB) welding as the most suitable form of welding in the space environment [28].

In 1979 on board the Soviet orbital station Salyut-6, processes for coating deposition on different material substrates were investigated. In 1984 outside of Salyut-7, a manual electron beam tool, URI, was used by cosmonauts to perform welding, brazing, cutting, and spraying (Figures 3.2 and 3.3). This was the first time cosmonauts had performed manual welding in space. Multipurpose electron beam tools from 1 kW to 3 kW have been developed and can be used manually or in automatic systems.

From 1985 to 1990, several experiments with the "Yantar" unit were performed on coatings, brazing alloys, and welding of metals inside the Soviet space station, Mir. An open space experiment deployed a 12-meter truss



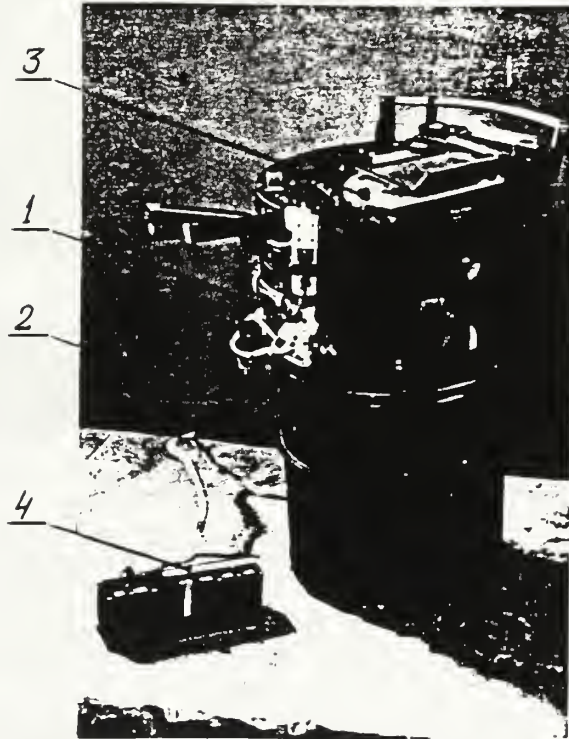

Figure 3.1 Vulcan welding unit [28]

- 1 - unpressurized bay;
- 2 - pressurized bay;
- 3 - rotatable table with specimens;
- 4 - remote control panel





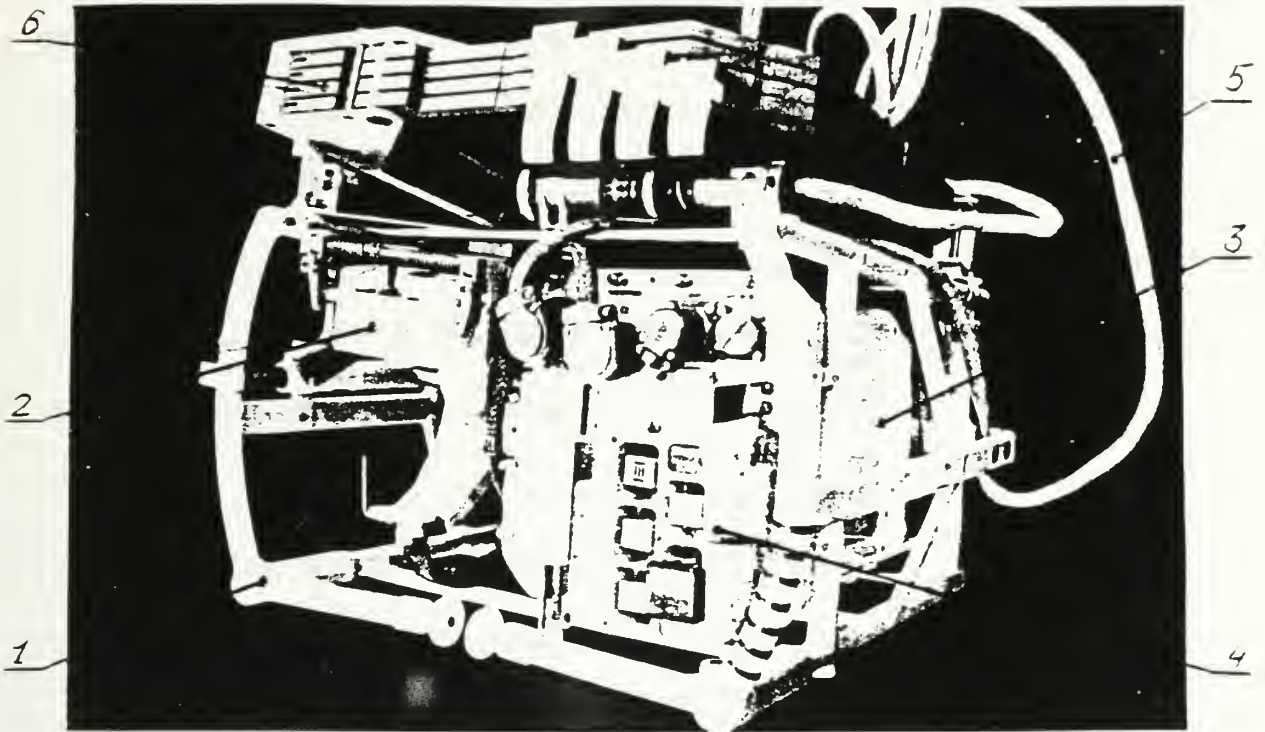

Figure 3.2 Versatile EB hand tool system (URI) [28]

1 - wire-mesh container; 2 - work tool;  
 3 - pressurized instrument bay; 4 - control panel; 5 - cable communications; 6 - board with specimens

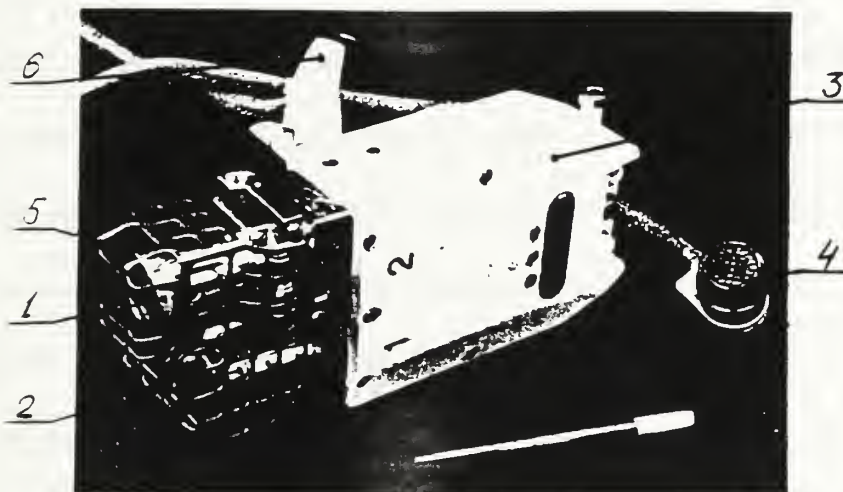

Figure 3.3 Versatile work tool [28]

1 - electron beam gun for welding, cutting and brazing; 2 - electron beam gun with a crucible for evaporation; 3 - high-voltage supply unit; 4 - connecting cable; 5 - heat-protective screen; 6 - handle



structure using welding and brazing with the help of the URI. Later in 1990, two more truss structures (15 meters) were built to support solar cells for the technology module Crystal, docked to Mir. [23]

In the U.S. space program, the only welding experiments performed in space were conducted on Skylab. Of the 54 experiments conducted on Skylab, only 3 of them were related to welding:

1. Metals melting experiment, M551
2. Brazing experiment, M552
3. Sphere forming experiment, M553

The first experiment melted three types of metal, aluminum alloy (22019), stainless steel (321), and thoria dispersed nickel, using an electron beam. The experiment demonstrated the feasibility of EB welding, cutting, and melting in microgravity. The microstructure of the melted metals were later examined and compared to similar samples welded on earth.

The second experiment demonstrated the feasibility of brazing as a method of repair and maintenance. A thin-walled stainless steel tube with a slit in the center was used to simulate an end-to-end joining exercise. A stainless steel sleeve was placed over the slit and brazed using an alloy of 71% silver, 28% copper, and 0.2% lithium. The experiment results showed that gaps were better filled due to superior wetting and spreading of the Skylab samples as



compared to ground based samples. Also, the Skylab joints were of better quality since they had less defects such as porosity. There appears to be no limit to the size of the braze gap in space, so the tolerance of gaps between two parts need not be too tight. Brazing can be used for some applications in space that would normally be joined by welding on earth.

The third experiment produced metal balls using an electron beam as a heat source. The purpose of the experiment was not to weld, but to produce perfectly symmetric spheres in a microgravity environment. [57]

It is evident that the former USSR has had much more experience in space welding than the United States. Also the majority of experiments have been performed in simulated environments such as vacuum chambers and parabolic flight on board aircraft.

### **3.2 Other Forms of Remote Welding**

The following forms of welding are similar to space welding in that they are in remote, hazardous, or constrained environments. Some of the automated technological innovations developed for space welding may also be applied to these forms of welding.



### 3.2.1 Underwater Welding

Welding in a submerged environment has several similarities to space welding, certainly from an operational aspect. Divers who perform the welding must have breathing equipment. They typically wear a protective suit and gloves, which reduces their dexterity and with that, the likelihood of producing a high quality weld. As with EVA, the amount of time for welding underwater is limited by human physiological factors.

The welding environment underwater is completely different than welding in space. Instead of vacuum, there is seawater under high pressure, which varies with water depth. Although gravity is present on earth, the underwater equipment can float if made neutrally buoyant. Molten metal will cool faster underwater since a conductive medium exists to quickly transfer the heat. Loose metal globules will tend to sink deeper in the water rather than float as they would under microgravity.

Underwater welding is remote since a trained diver is needed to travel to a remote location and manually weld or an underwater vehicle (manned or unmanned) is used for robotic welding. If the water is too deep, diving might not be a viable alternative. This is quite analogous to welding in space. An astronaut can weld manually or a telerobotic platform (or some automated system) could be used for robotic welding. Of course, it is much less expensive to weld underwater than it is to weld in space since oceans are much easier to





access than outer space.

Although there are many differences between underwater welding and space welding, the basic principles developed for telerobotic human-supervisory welding should be applicable to both forms of welding.

### **3.2.2 Welding Inside Nuclear Reactor Vessels**

Although human welders can work in a radioactive environment with some protection, they can do so only for a limited amount of time before there is danger of serious health risks. Remotely operated welding has been used in areas where there is danger of excessive radiation exposure to human operators.

Robotic arms have been designed and constructed to reach and conduct repair work inside reactor vessels. [43, 60] Typically the telerobots are custom made for the task at hand. Several end effectors are designed to perform various jobs, such as cutting, grinding, or welding. Video monitors are used throughout the repair process, including for weld and quality inspections.

Mock-ups of the work site are usually created, simulating the work conditions that are expected, such as higher pressure or an underwater environment. Testing in the mock-ups ensures that the work will be done properly without too many unforeseen problems when actual in-vessel



operations begin. The fabrication experience of remote nuclear reactor repair can surely be used for the development of telerobotic welding in space.

### **3.2.3 Space Limited High-Rise Construction**

In Japan, several companies have begun to incorporate construction techniques using robotic welding devices for high-rise building construction. For example, one technique uses vertical box beams that must be welded from the inside. Since a human welder cannot do this task, a robot is used. A human observer is always present to ensure the robot is functioning correctly. This observer can be likened to a human supervisor who has overall control of the process. Research is currently being done on the best way for a single supervisor to monitor several of these welding robots.

Welding on a high-rise is considered hazardous duty for most welders. A telerobotic human supervisory system can help to improve the safety of this work.

There are also many more examples of the use of automation to extend human control into confined spaces. One example is the use of the endoscope for telesurgery to perform inspections, biopsies, and simple medical surgery.



### **3.3 Automating Space Welding**

This section describes a few methods of welding automation that have been designed for use in space, and introduces the application of telerobotics and human supervisory control to welding in space.

#### **3.3.1 The "Instamatic" Welding Concept**

In July 1982, researchers at the Massachusetts Institute of Technology (MIT), under the direction of Professor K. Masubuchi, devised a way to package fully automated welding systems that could perform several welding operations such as electrode feeding and torch manipulation. Although the machines were designed to create only specific weld types, they are unique because they can be operated by persons with little or no welding skills. Joint types that were welded include stud welding a bar to a flat plate, fillet welding of two perpendicular plates, and lap welding a cover plate to a flat plate (see Figure 3.4).

Originally intended for remote deep-sea welding, the "instamatic" welding system is ideally suited for welding in space. [57] This system could repeatedly perform simple welding tasks after being positioned by a robotic device or by astronaut EVA. For a telerobot, these systems can be used as end-effector



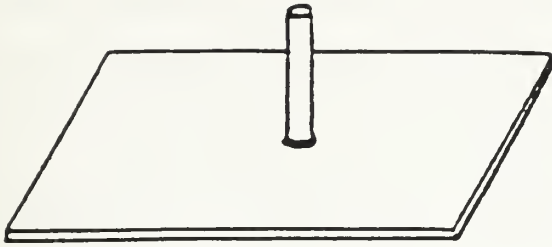

a. STUD WELDING A BAR TO A FLAT PLATE

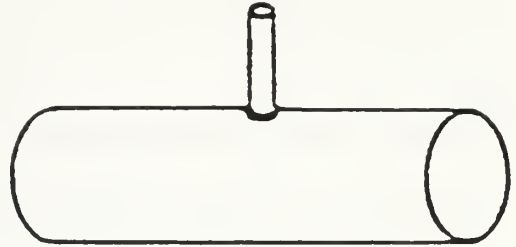

b. STUD WELDING A BAR TO A PIPE

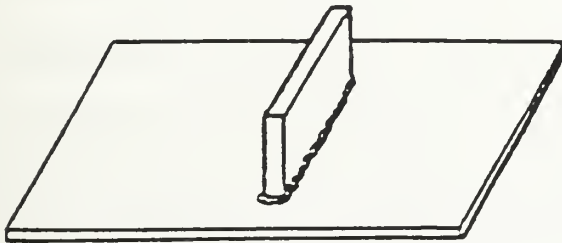

c. JOINING A PLATE TO A PLATE BY FILLET WELDING

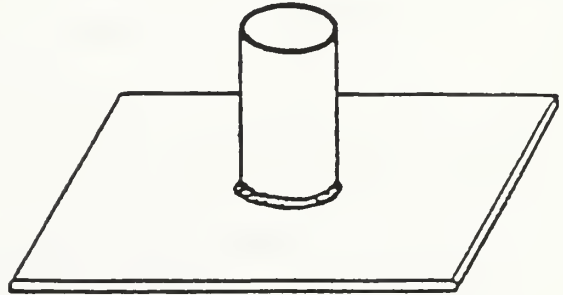

d. JOINING A PIPE TO A PLATE BY FILLET WELDING

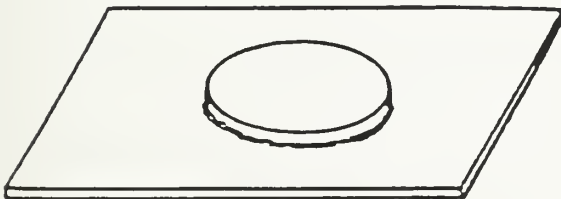

e. LAP WELDING A COVER PLATE TO A FLAT PLATE



f. REPLACING A SECTION OF A PIPE

Figure 3.4 Some joint types for instamatic welding systems [57]





tools attached to a manipulator arm, which needs only to position the tool in the proper location and signal the welding to begin.

Such systems show that an automated welding device can be created to replace manual welding with a tool in one hand and an electrode in the other. Instamatic welding would certainly be faster and therefore more efficient than an astronaut welding manually in an EVA suit (not to mention safer). But since each machine can perform welds on only one geometric configuration, their application is very limited. In space it is too expensive to carry the extra weight of several welding machines. If a single telerobotic platform could be created that could handle any geometric configuration, it would prove to be a much more feasible solution.

### **3.3.2 Automated Welding Experiments in Space**

Section 3.1 mentions the first welding system in space, the Vulcan welding unit (Figure 3.1). This unit was automated by using a rotatable table on which specimens were welded. The system can perform three welding methods: electron beam, low-pressure constricted plasma jet, and consumable electrode welding. The system was placed in the living bay of the Soyuz-6 spacecraft, which could be depressurized. The crew would operate the system from the pressurized landing vehicle while the living bay was depressurized for



the experiment. The experiments were controlled by a remote control panel, which was connected to the unit via electrical wire. [28]

The USSR space program performed several other experiments using the automated systems known as the Isparitel, Isparitel M, and Yantar units. These systems performed experiments in coating deposition, melting of spheres for materials production, and welding of thin metal specimens. These systems were automated and controlled remotely or by preprogramming. The systems were designed and used primarily for experiments, not for practical use. One exception is that the Isparitel M unit can be used for coating deposition on the external surfaces of space vehicles. The URI (Figures 3.2 and 3.3) was designed for practical welding in space, but only for manual welding. Automated welding could be performed using a modified URI as an end effector for a robotic manipulator.

### **3.3.3 Welding Planned for Space Station Freedom**

The Space Station Freedom Program Definition and Requirements baseline specifications for the logistic, laboratory, habitation, and node modules are outlined as follows:

1. There will be no welding on-orbit for the assembly, maintenance, or



integration of Space Station Freedom except in the standoffs and end cone sections. [Note: all tubing and valves for the Environmental Control and Life Support System (ECLSS) and distributive systems will be located in the standoffs and end cone sections.]

2. The material specifications state that all tubing and valve assemblies for the ECLSS and all distributive systems will be titanium or stainless steel.
3. All valves in the ECLSS and the distributive systems will be welded in place. All valves and tubing will be fully installed and integrated prior to launch of each module. [85]

As of now, there are no plans to perform welding in the on-orbit assembly phases of Space Station Freedom. But plans are needed for maintenance operations that will need to cut and join metal reliably. Specifically, all the valves in the ECLSS and distributive systems are not expected to last the 30-year design life of the space station.

For example, examining one of the systems at Permanent Manned Capability (PMC) of the space station, such as the supply rack air control valves, the system will have 45 valves. Each of these valves has an estimated mean time between failure (MTBF) of 54,600 hours (6.23 years). Over a thirty-year life of the space station, about 217 valve replacements will be needed for



this system alone.

One proposed solution to the valve replacement problem is to use an electrostatic discharge machining (EDM) cutting method within a semirigid bladder-like glove box, followed by welding using a self-contained gas tungsten arc welding (GTAW) system. The purpose of the glove box is to contain and dispose of cutting particles and welding fumes.

The EDM cutting method involves applying a voltage to an electrode in the presence of a dielectric medium. The electrode is typically graphite and is placed in contact with the pipe much like the way a wire cheese cutter is used. Controlled arcing and localized heating occur as the electrode is energized through ionization between the tube and the electrode. The cutting method is slow but controlled and results in a surface that is properly prepared for butt welding. [85]

Commercially available GTAW equipment can be used for automatic welding of tubing, piping, and fittings. An orbital welding head is ideally suited to perform this form of rotary welding. The welding process is computer controlled, requiring the operator only to properly position the tool and input the welding functions and parameters. Since only four welding functions and two materials are planned for the space station valves, the settings can be pre-programmed for ease of operation.





### 3.3.4 Using Telerobotics for Space Welding

Unlike robotic welding on earth, it is important to remember that remote welding does not only consist of welding itself but also requires other manipulations such as prefabrication, joint preparation, proper positioning of the pieces to be joined, post-weld inspection, and NDTs. Ordinarily, these manipulations are performed by humans so most robotic welders are designed just to weld.

The instamatic welding system described in Section 3.3.1 could be incorporated into the design of a telerobot that has one or more manipulators capable of performing several types of welding processes. Such welding systems could be preprogrammed to perform automated welding sequences in between modes of manual operation. For example, if 90% of the welding processes can be programmed and performed autonomously, a human operator will need to intervene for the remaining 10% of the processes when a situation arises that is nonstandard. Among those processes that are nonstandard, they can most likely be divided into sub-tasks, which can be preprogrammed and executed on the operator's command. It is the human operator who must ultimately perform higher level task planning, make decisions, weigh trade-offs, and teach the telerobot skills when necessary. Therefore, a human supervisory telerobot seems to be a suitable solution for the task of space welding.

Several obstacles must be overcome before telerobotic space welding



can become a reality. Before robotic welding is to be attempted in space, fundamental experiments in space welding need to be accomplished. Additionally, the use of telerobots in space to perform simple servicing and construction related tasks needs to be established. And once we attempt to weld in space using telerobotics, how can we best perform the task? What feedback would the operator need to weld adequately? Which tasks should the operator perform and which can the robot be allowed to handle autonomously? If a robot is to perform a weld autonomously, which parameters need to be sensed and with what sensors? These are some of the questions that will need further research before telerobotic space welding can become reality.

When welding in a remote location, joint preparation will need to be considered. When welding for new construction, the pieces may be cut to size and shaped properly for welding prior to launch. For repair work, the size and shape of the pieces required cannot be known in advance. Either a large stock of materials with different dimensions is required, or pieces can be cut to size from a stock of larger materials. Such prefabrication can be performed by using telerobotic manipulation.

After the weld is complete, the quality of the weld joint needs to be evaluated. On Earth, there are several methods to determine weld quality known as non-destructive tests (NDTs). Therefore, in a remote location, the telerobot may need to be equipped to perform one of these NDTs.



## Chapter 4: Defining the Welding Fabrication Problem

Before designing a telerobotic welding system that will be used in space, it is important to examine current welding technology that will contribute to the development of this system. Welding fabrication can be broken into sub-tasks that include joint and surface preparation, manipulation of tools, process control, evaluation of joint and weld quality, and higher level planning.

It should be recognized that the design of structures is affected by the method in which it is to be joined. The design of mechanically connected space structures can be much more complicated than the design of welded structures. In many cases mechanical joints will cause the finished structure to weigh significantly more. For welding tasks, the joint preparation may be just a matter of using prefabricated parts and placing them in the proper position prior to welding. The prefabricated parts can be created on earth, then launched into orbit. Alternatively, welding offers the advantage of simpler joint design so that parts may be cut from a standard supply of a material if an unforeseen repair job is needed.

Surface preparation involves a degree of quality control prior to welding. The surface may need grinding to ensure the joint fit-up is adequate. If a part has been cut, it may be necessary to remove burrs or large bumps. If cold welding is to be performed, a layer of oxidation and contaminants may need to



be removed. [39]

It is necessary to manipulate tools in all portions of the fabrication sequence. Tools need to be positioned at points in space in arbitrary orientations. A frequent manipulation in welding and inspection is tracking of a two- or three-dimensional path at a constant speed, distance, and orientation from a surface.

Process control in welding involves sensing the weld characteristics, comparing them to the desired characteristics, and making corrections to the welding process parameters. [57] It is therefore essential to adequately sense the parameters as well as the resulting weld quality. One important aspect in welding control is that the ultimate output of the process (the solidified weld bead) is known only after completion of welding, and the input conditions cannot be changed before the weld solidifies. Therefore, it is very important to have an accurate model of the welding process parameters and weld characteristics to get the job right the first time.

The joint and weld quality needs to be monitored at each step of the fabrication. During joint preparation, the joint geometry and gap sizes between parts to be welded need to be verified. During welding, parameters can be sensed to ensure a proper weld is being made. After the weld has solidified, an NDT is usually performed to ensure it is within design specifications. Such specifications include weld bead location and geometry, weld and base metal microstructure and metallurgical properties, and structural integrity of the joint.





The most popular NDTs for welds include visual, liquid penetrant, magnetic particle, radiographic, and ultrasonic [16]. Visual inspections can determine only the weld's surface characteristics, but they are very important during the welding process itself. Weld bead dimensions and surface defects can be determined visually. Small surface cracks can be found using liquid penetrants, but this is not feasible in space since liquids can be difficult to handle in a microgravity environment. A magnetic particle inspection helps to find surface or near-surface discontinuities in magnetic materials but similarly, it is not a good candidate for space. Radiographic and ultrasonic inspections are used to find internal weld discontinuities. To use ultrasonic testing in space outside the spacecraft, the equipment must be designed to firmly make contact with the weld since no air is present to help the sound waves propagate.

After the weld is accepted, there is also the question of whether or not the exposed weld is to be left uncovered and exposed to the environment. If the surrounding area is coated or painted, there may be temperature differences in the adjacent regions. The thermal variation is due to the different absorptivity characteristics of the surfaces to the sun's radiation. Such thermal differences could be significant enough to produce undesirable stresses if the region is exposed to sunlight. [4]

Higher level planning involves selecting the type of process to be used, and defining the joint preparation and welding parameters. The welding parameters are the initial inputs that control the size, shape, and quality of the



welded joint. These process variables are of course dependent on the type of welding (EBW, arc welding, etc.) and on the environmental conditions (underwater, space, earth). Higher level planning is normally performed by a welding engineer who interprets the designer's specifications and iteratively adjusts the welding conditions based on his expertise. For remote fabrication, this expertise is normally not present so parameters must either be preset for particular tasks, adjusted by the experts through telepresence, or adjusted locally using a computer-based expert system.

Many approaches to automatic selection of welding parameters require modeling of the complicated heat transfer phenomena that take place during welding to predict the shape and quality of the weld bead. [84] Empirical models require much experimentation, and it is very difficult to generalize the results. Analytical models tend to be too simplistic, making them impractical. Another way to select welding parameters is by direct feedback of the weld characteristics using real-time sensing techniques such as visual [3], thermographic [21], or radiographic [70]. This data can be used to self-train the system, just as welding engineers train themselves, using a small database to estimate the initial parameters and simple rules to make iterative adjustments. Even if most simple welding processes can be automated, human interaction remains vital for higher level planning and decision making tasks such as sequencing of construction or unforeseen repair operations.



## 4.1 Advantages of Welding

Although plans for the on-orbit assembly of Space Station Freedom do not include welding, future space structural designers should consider this form of joining. Welding has inherent advantages over mechanical joints for the following reasons:

1. In general, welded joints weigh less than mechanical joints.
2. Air tightness can best be achieved with welded joints.
3. Welded structures have high rigidity.
4. Mechanical joints may become loose over the service life of the structure.
5. Welded joints have higher strength over a wide temperature range as compared to mechanical joints.

When payloads are launched into space, it is only a small portion of the original weight of the entire launch system. And since space flights are so expensive, it pays to minimize the weight of that payload as much as possible. A large proportion of the weight of spacecraft and space habitats consists of



structural weight. Of that weight, a significant portion is needed for joining the structure. Welded joints can be designed to be lighter than mechanical joints and therefore should be considered in order to reduce cost.

Mechanical seals can be used to preserve airtight integrity of a spacecraft, but welded joints provide a much more reliable method of obtaining a permanent seal. Mechanical seals have a tendency to wear out with time and when the structure is placed in conditions of dynamic loading. In the event of a collision, a welded joint is more likely to survive than a mechanical seal.

Rigidity is an inherent characteristic for welded joints, while mechanical joints are less rigid. Lower rigidity means that the structure will have less ability to maintain its exact shape, especially under various loading conditions. Similarly, mechanical joints often become loose during the service life of the structure. For structures exposed to the sun, thermal expansion cycles make joints especially susceptible to this phenomenon.

Mechanical joint designs tend to have smaller effective cross-sectional areas than the same joint welded. This is due to design details such as holes and voids. These same details can introduce areas of high stress concentration into the structure when it is placed under loading. Welded joints therefore tend to have higher strength than mechanical joints with the same scantlings.





## 4.2 Requirements for Welding in the Space Environment

The space environment has unique characteristics that must be considered prior to conducting welding operations. The three major effects on the welding process are:

1. High vacuum
2. Microgravity
3. Sudden drastic temperature fluctuations

These conditions can be simulated using vacuum chambers in parabolic flight, but only for short periods of time. If welding is performed inside the spacecraft, then microgravity is normally the only major effect. Other environmental factors that affect the design life of the weld is that of meteorite impingement and damage from radiation and atomic oxygen. [44]

The presence of a vacuum can be beneficial to some welding processes and detrimental to others. Cold welding is a phenomenon that occurs in a vacuum when the thin layer of adsorbed gases and contaminants is removed from metal surfaces. The vacuum prevents the contaminant layer from reforming and allows the outer electron shells of the metal atoms to interact. When the metallic surfaces come in contact they are welded by electrostatic surface forces as well as the application force. [26]

Electron beam welding (EBW) also requires a vacuum for the process to work. In EBW a stream of high-velocity electrons bombard the workpiece,



creating heat by the transfer of kinetic energy of the particles. The process requires no shielding gases and no application of pressure. Without a vacuum, the process is much less effective because the electrons in the beam collide with gas particles, thus reducing their kinetic energy.

When arc welding is conducted in a vacuum, there is often a problem with arc stability. To maintain an arc, necessary electron flow is supplied by a shielding gas or by the atmosphere itself. Shielding gas disperses more quickly in a vacuum, making the arc welding much less effective. Although the electrons can be obtained from the electrode itself through thermionic emission, more power is required and arc stability is weakened. The former Soviet Union has developed a method to overcome these difficulties known as hot hollow cathode welding (HHCW). In this form of plasma arc welding, a multi-step system is used that has an arc gap between an internal auxiliary electrode and the hollow cathode. The gap arc heats the cathode walls and promotes cathode transition to a thermoemissive mode of operation, thus creating the main discharge [66]. With this design, a stable arc can be achieved in vacuum.

Vacuum also affects the rate of cooling on the weld. Since there is no gas around the weld, heat transfer through convection is nonexistent and must be accomplished through radiative and conductive processes. Radiation from the sun is not absorbed by an atmosphere, leading to higher radiative heat transfer to the structure. If welding is conducted in the shade, radiation losses to deep space are much higher than if conducted on Earth. Cooling rate of the



weld strongly affects the microstructure and other physical properties of the final weld.

Gravity also has an effect on convection, not outside the weld, but within it. In microgravity, convection will not occur as it does on earth. Higher temperature, less dense portions of the weld bead will not tend to rise to the surface. Gravity also affects solidification of the weld through its effect on fluid motion and hydrostatic forces [71]. In addition to convection, the force of buoyancy also drives the formation of sedimentation. If there is no gravity gradient, buoyancy will not bring gas bubbles and voids out of the weld, resulting in high porosity. Since the weld pool is affected by fluid forces and flow, its shape upon cooling will be different in microgravity than it is on earth.

In space, gravity is no longer a dominant force. Therefore, other forces will tend to become more significant during weld formation such as:

1. Lorentz force: Electromagnetic force induced by current flow through a specimen.

2. Electrostriction: Stresses caused by the change of the electrical dielectric constant with density.

3. Magnetostriction: Stresses caused by the change of the magnetic permeability with density.



4. Electrostatic force: Force due to an excess static electrical charge.

5. Surface tension: Force created at the surface of a gas-liquid or liquid-liquid interface due to the attraction of surface molecules.

6. Force induced by density differences during phase changes.

7. Beam force: As in EBW, electrons impacting the workpiece produce forces by transferring their momentum.

8. Thermal Expansion Forces: Changes in temperature cause materials to expand or contract and can create forces if physical boundary constraints exist.

All of the above forces exist in a gravity field, but are much less dominant than the gravitational force and are normally negligible. Of these forces, surface tension will usually dominate in the absence of gravity. Therefore, in space, the shape of weld beads, wetting, and spreading characteristics will be governed for the most part by surface tension.

As mentioned above, heat transfer in space is very much influenced by the presence of vacuum. More radiation reaches an object in space since the energy is not filtered by an atmosphere. There is no atmospheric convection,





so radiation is the only significant form of heat transfer for an isolated object in space. For a weld bead on the exterior of a spacecraft, heat conducts via the base plates as well. In addition, there can be sudden drastic temperature fluctuations caused by the orbital trajectory of the structure when it becomes shadowed by the Earth or rotated with respect to the sun to either expose or shadow the welding area.

The skin of the space station is expected to range from + 250 to -250 degrees fahrenheit depending on whether or not the surface is exposed to the sun. The same structural member may experience temperature variations, resulting in thermal stress and possibly significant deformations. Welded joints need to be designed to withstand constant thermal cycling when in orbit.

The temperature of the structure can be controlled by changing the surface properties (absorptivity and emissivity) by using paint or coverings. Bare metals act as solar absorbers, while painted surfaces have a higher amount of reflectivity (even if painted black). [4] Although the surface properties of the weld would be difficult to change, the base plates adjacent to the weld could be covered to help control the temperature gradient near the weld. All these factors will affect the cooling rate of the weld bead and thus the microstructure and physical properties of the weld.

While the structure is in orbit for a prolonged period of time, there is the possibility of meteorite and particle impingement on the weld joint, and radiation degradation, which could lead to premature localized failure. The Long



Duration Exposure Facility (LDEF) was retrieved from nearly a 6-year orbit on January 12, 1990. The data gathered from LDEF and the experiments carried on board can be used to help design structural members and joints of spacecraft to withstand degradation from debris, radiation, and atomic oxygen.

[44]

#### **4.2.1 Some Lessons Learned from the USSR Space Program**

Weightlessness, vacuum, and the presence of sharp light-shade temperature boundaries are the three main characteristics of space that significantly affect welding processes. The typical range of atmospheric pressure in low Earth orbit (LEO) is from  $10^{-2}$  Pa to  $10^{-4}$  Pa. When constricted (plasma) low pressure arc welding is performed with a hollow cathode, the presence of a vacuum drastically deteriorates the stability of arc discharge excitement and arc constriction at low currents. In consumable electrode arc welding, a low pressure makes it necessary to apply the forced methods of arc discharge constriction. EBW, however, is not adversely affected when performed in a vacuum.

All of these welding processes are greatly affected by weightlessness. For example, for consumable electrode arc welding at low currents ( < 100 A), the molten drops of metal can become undesirably large. More controllable



methods of melting and electrode metal transfer are therefore needed in a space environment. Weightlessness does positively affect weld formation by preventing undercuts. There is some increase in weld porosity, especially when welding aluminum alloys using an electron beam and plasma cutting. For liquids and gases, physical phenomena such as buoyancy and convection are suppressed or absent. If there is a difference in density of materials or their phases then such phenomena becomes less of a factor. When gravity is absent, other physical phenomena become more dominant such as surface tension, adhesion, wetting, and capillary pressure. [48]

There are always temperature fluctuations in earth orbit due to the spacecraft's orientation and intermittent exposure to sunlight. Every time the spacecraft goes through the sharp light-shade boundary of a sunrise or a sunset, radiative heat is suddenly added or removed. Heat is transferred not by convection, but through conduction and radiation, so objects tend to retain applied heat for a longer period of time than if convection were present.

The "Vulcan" welding unit developed by the USSR was used to perform tests in all of the above welding processes. The results of these tests confirmed data gathered on earth: EBW is likely the optimum method for space conditions. Not only can more versatile equipment be designed using EBW, but energy effectiveness is much better than in other welding methods. A larger percentage of the consumed energy in EBW is applied to the workpiece as compared to plasma and arc welding, which lose more energy through heating



the tool.

It has been found that joints brazed in space are practically indistinguishable from those done on earth. There is no difference in strength or tightness. Brazing is easier in space since surface tension and wetting are more dominant than when welding on Earth.

When welding in space, the weld pool does not flow along a gravity gradient as it does on earth. Even for thin plates in which the weld pool extends through the thickness of the material, the weld pool stays together. This characteristic is very useful for welding holes in plates and similar repairs.

Russian space experience has shown that for most materials, welding technology and the quality of welded joints do not differ significantly between a space and an earth environment. But when welding aluminum alloys or other alloys with a high percentage of dissolved gases or volatile components, the welds tend to have a high porosity. Figure 4.1 contrasts the degree of porosity for electron beam welds made in weightlessness, on Earth, and in transition from weightlessness to a gravity field ( $> 1.5 g$ ). Methods do exist to prevent this phenomenon using modulation of the electron beam. [48]

Cutting metals using an electron beam is well suited to the space environment since it does not create loose spatters of molten metal, which could easily damage a space suit. One difficulty occurs when the weld pool clings together through surface tension. The cut edges have a tendency to flow back together and reseal the opening. In such cases it is necessary to force





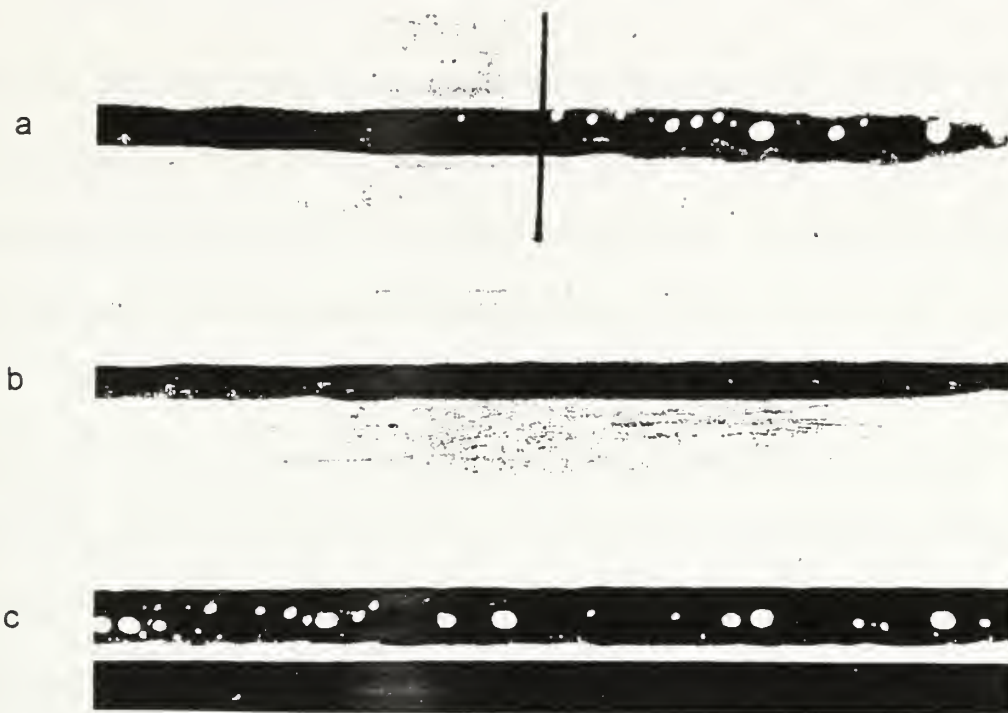

Figure 4.1 Pore formation in welds by EBW of AMg-6 alloy [48]

- a - in weightlessness;
- b - on Earth;
- c - in transition from weightlessness to the overloading  $> 1.5 g$



Figure 4.2 EB cutting in zero gravity a) with and b) without controlled cooling of one side of the cut [48]



the weld pool apart with a specially formed heat dissipation that makes one side of the cut cooler than the other. The drops will then solidify more readily on the cooler side without recombining. Figure 4.2 compares two zero-gravity electron beam cuts with and without controlled cooling of one side of the cut.

Space welding is not well established in the U.S. space program, but we can use the lessons learned by the Soviet space program. They have created and used EBW technology for space applications. Their designs incorporated safety, high reliability, and minimum mass and energy consumption. The power consumption for such designs are rated at 1.5 to 3 kilowatts. [28] The URI is one example of a hand-held versatile tool that could be easily adapted for use by a telerobot. Figure 4.3 shows an example of a hand-held electron beam gun design.

### **4.3 Possible Applications of Welding in Space**

There are limitless applications to welding in space, and the majority are yet to be imagined. Section 3.3.3 describes a possible welding application involving valve replacement on Space Station Freedom. This section describes a few possibilities for space welding as well as welding on the Moon and planets other than Earth.



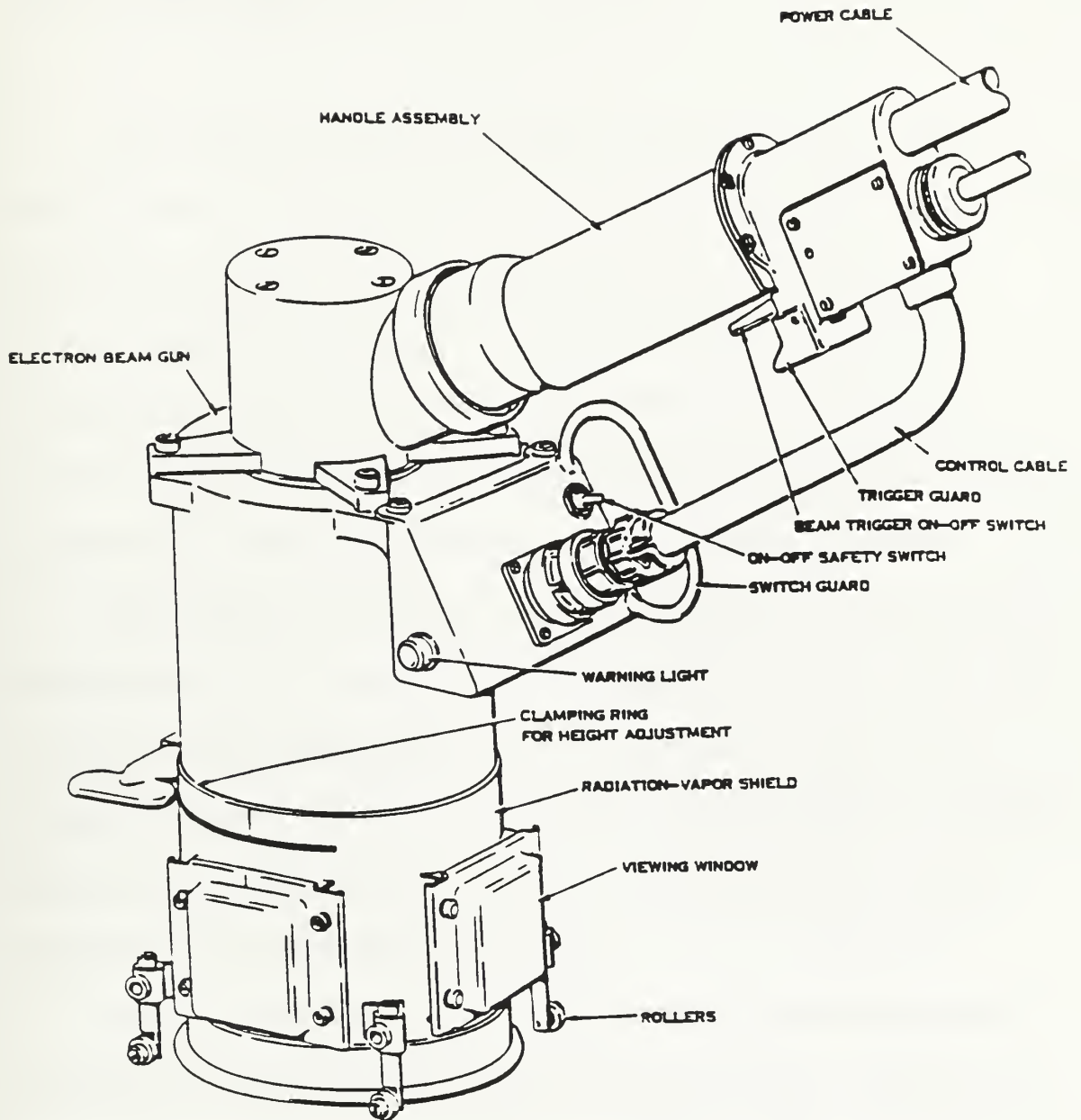

Figure 4.3 Prototype of hand-held EB gun



### **4.3.1 Construction**

#### **4.3.1.1 On-Orbit Structures**

One of the first applications of space structural welding took place on board the Soviet orbital station Salyut-7 in 1986. An experiment was performed on truss construction in space. Equipment was designed to automatically deploy a folded truss, packaged in a compact cylindrical unit 0.7 meter in diameter and 1.5 meters in length. Once unfolded, the truss extended to 12 meters in length. The members of the truss were thin-walled tubing 15 mm in diameter. [23] Figure 4.4 shows the unit used for deploying the truss.

After unfolding the truss, two cosmonauts welded and brazed some of the truss joints. The versatile electron beam hand tool, URI, was used. The welded joints were later returned to Earth where they were examined for strength and quality. The evaluation concluded that, even using an extremely limited amount of power, good quality welded and brazed joints could be obtained for thin-walled structures in space.

The U.S. space program has performed similar experiments of orbital construction of trusses, but without using welding or brazing. Automated units were not used to erect the structure. Assembly was performed by astronauts in EVA. Two EVA space construction experiments were launched on the space shuttle (STS 61B) on November 26, 1985. One experiment was called the





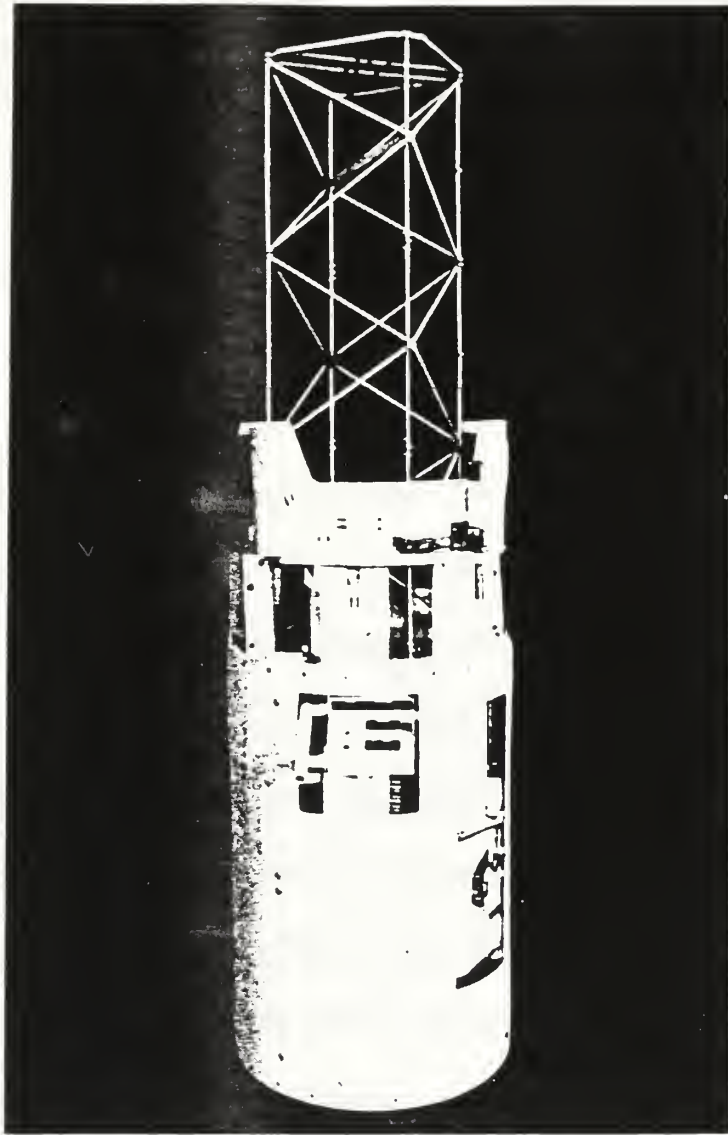

Figure 4.4 Unit for transformable truss unfolding/folding [23]



Assembly Concept for Construction of Erectable Space Structure (ACCESS) and the other was known as the Experimental Assembly of Structures in EVA (EASE). For both experiments, the objective was to evaluate the performance of astronauts in EVA while performing space construction tasks. [34]

To join the structural beams to node joints, mechanical connectors were used to lock the beam in place. Figure 4.5 shows the structural connector used for the EASE experiment. The two cylindrical ends interlock by using a machined geometry. A sleeve is pushed over the joint to keep the ends mated, then it is held in place using a spring lock. The joints are constructed with about one degree of rotational tolerance to allow the joint to be assembled more easily and to prevent cold welding the pieces together.

One possible solution to ensure rigidity and structural integrity of the joint, is to weld the sleeve in place after mechanical fastening has been completed. Figure 4.6 shows how the connector might look after welding both ends of the sleeve to achieve a permanently rigid joint. Such a configuration still allows for ease of construction while ensuring the joint is rigid. Welding joints in space also allows the structural designer more flexibility to achieve simple and lightweight joints.

Welding may enable larger structural designs to be produced than are now attainable given the size of current launch vehicles. For example, flights for space-based manned lunar transfer vehicles (LTV) or martian transfer vehicles may require some on-orbit assembly and checkout due to mass and



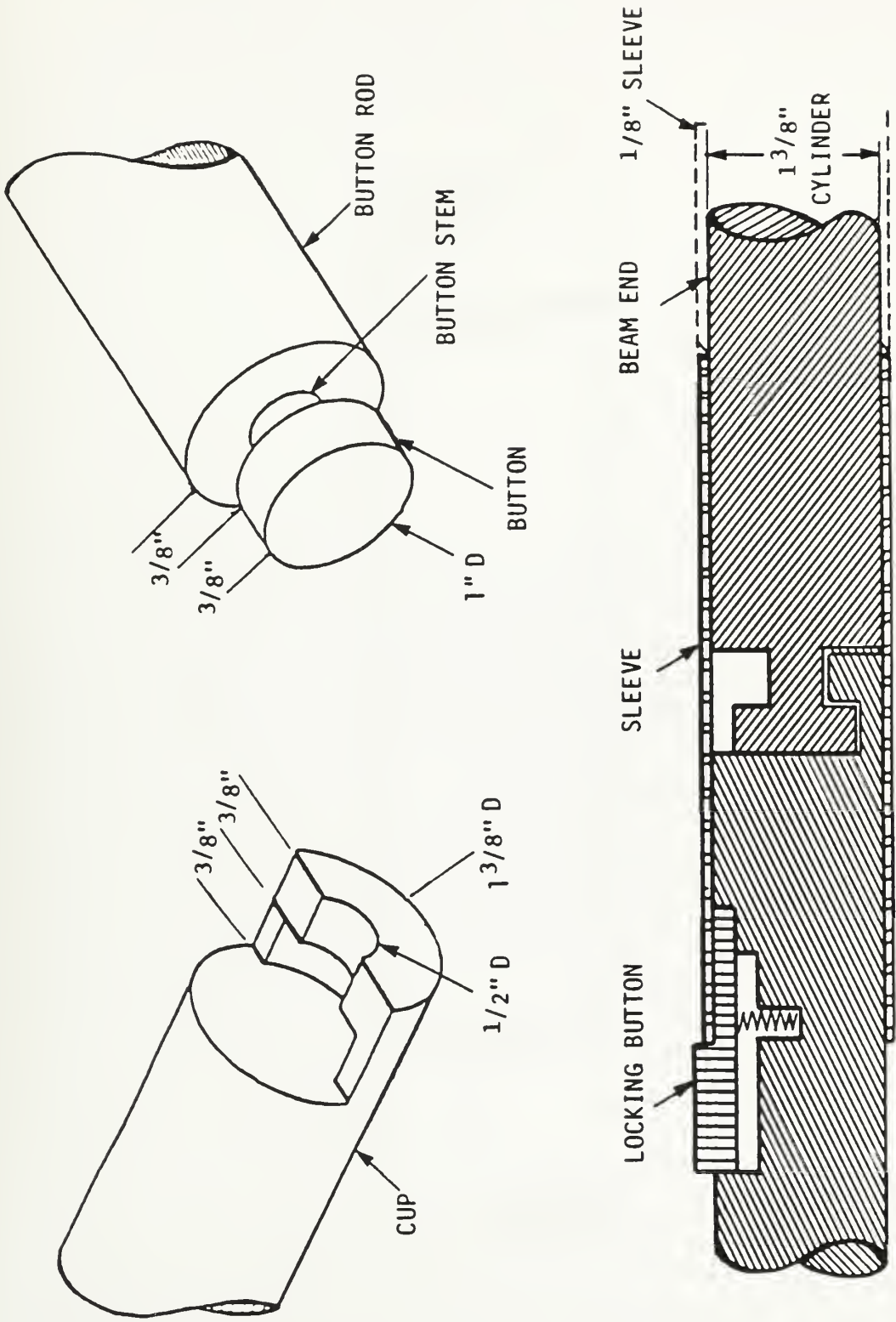

Figure 4.5 Prototype joint for use in space - MIT connector design [57]



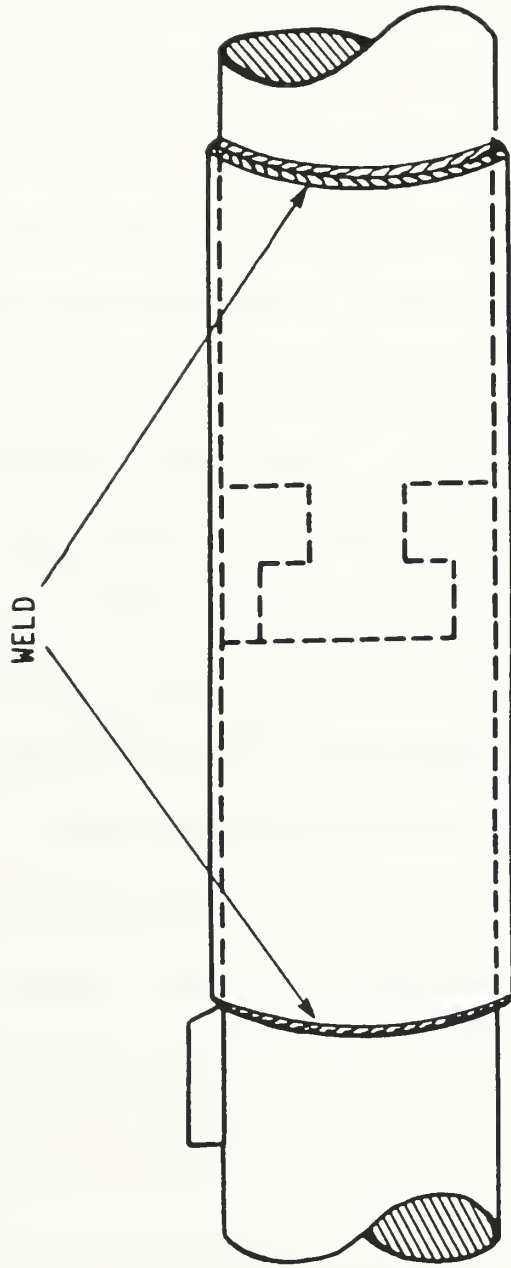

Figure 4.6 Possible permanent fastening of the MIT connector [57]





volume limitations of the launch vehicles. This will be possible by using Space Station Freedom as a transportation node in Earth orbit. Although designs can involve no on-orbit welding, the ability to weld during on-orbit assembly operations may allow for alternative designs that are more cost effective.

The Space Transportation System's (STS) external tank has long been a wasted commodity since this huge structure is brought to the edge of space. The external tank is made of an aluminum alloy that weighs 29,964 kilograms empty, and has an internal volume of over 2154 cubic meters. Current launch costs are at least \$4400 per kilogram, which is equivalent to \$132 million wasted per launch. [20] There have been several proposals made to make use of the external tank, but NASA has not been convinced that any of the ideas are worth financial support. Private companies may be the first to take advantage of this by-product of the U.S. space program.

The external tank could be reduced into construction materials. A study by the Air Force Institute of Technology has examined the feasibility of creating an Aluminum Salvage Station for the External Tank. This facility could process the external tanks into 1,866 meters of I-beams and 451.6 square meters of plate per external tank using welding and cutting techniques. [20] Future generations of space structures could be built from this vast supply of scrap aluminum.

An aerobrake is a large structure used to dissipate energy through aerodynamic drag rather than using retro-rockets to help slow down a space



vehicle as it descends toward the surface of a planet. An aerobrake would be especially helpful when landing on Mars due to the potential for significant weight savings. Figure 4.7 shows the design created by the Mars Mission Research Center. Typical of most aerobrake designs, a raked ellipsoid is used to provide lift during the aerobrake's travel through the atmosphere. Such structures are massive with dimensions on the order of 100 feet in diameter. The size and shape most aerobrakes require them to be assembled on-orbit rather than launched in one piece. Large pieces of the structure will need to be joined using hundreds of bolts and mechanical latches, or by welding. Welding has the advantage of providing joints with high rigidity that will not come loose during transport and rigorous high temperature atmospheric descent. [35, 49]

#### **4.3.1.2 Structures on the Moon and Mars**

One day humans will return to the Moon. The first visits will have scientific goals such as exploration, astronomy, Mars mission preparation, and sustaining life for extended periods. If the space exploration initiative (SEI) is to be successful, more permanent bases will later be created for both scientific and commercial use.

Welding will undoubtedly play an important role in building such structures. Creating an airtight environment will be essential for sustaining life



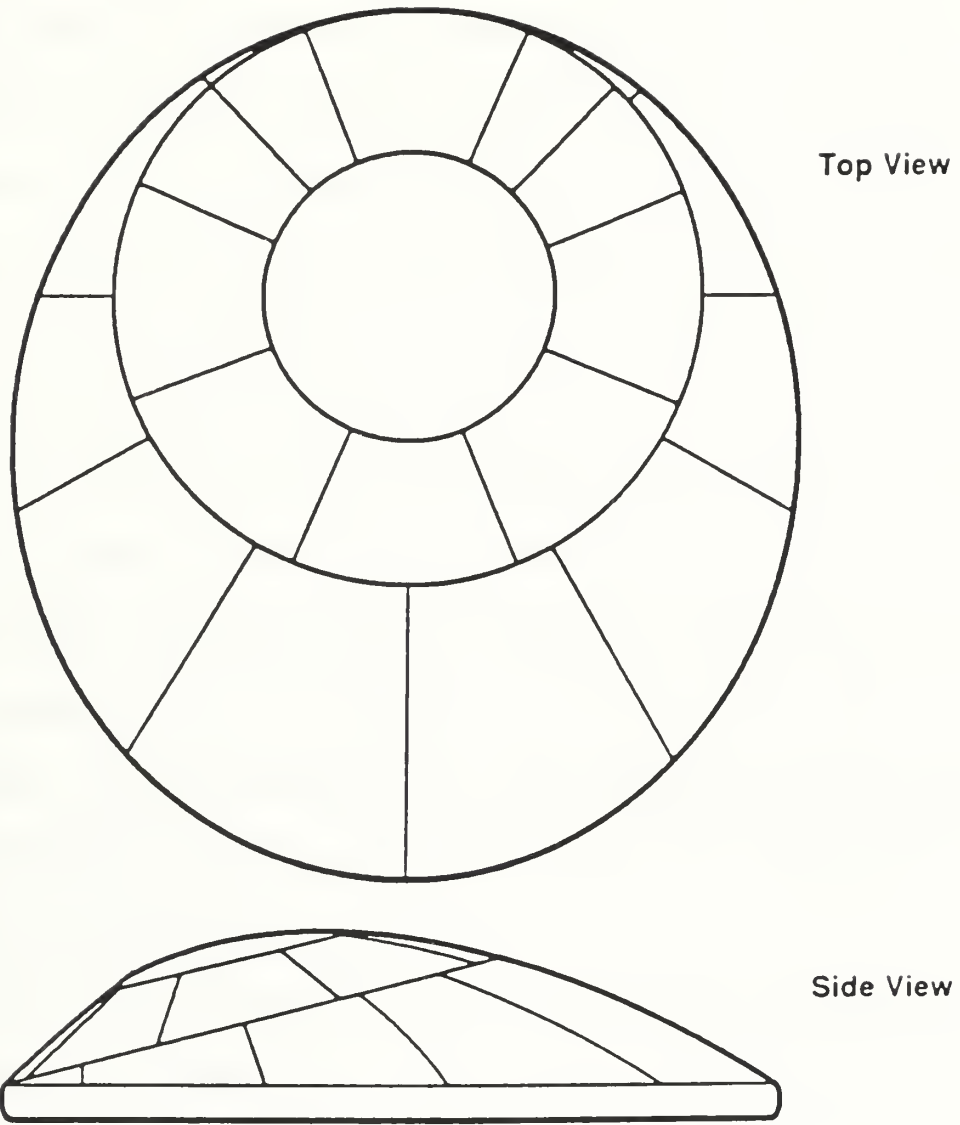

Figure 4.7 Top and side view of the MMRC aerobrake design [8]



and operations on the Moon. Welding is the most reliable method of joining to ensure that leaks are nonexistent. Moon's gravitational field make structural rigidity and integrity more of an issue than if the structure was in orbit.

Structures may be buried beneath the lunar soil (regolith) to help stabilize temperature and to provide some protection from meteorites and radiation. The pressure produced by 10 feet of lunar soil is about 110 pounds per square foot.

[19] High-strength, rigid structures will be needed, and welding is the most promising method for achieving this goal.

The effects of the Moon's environment on welding need to be considered since they differ from those in orbit. Essentially the same conditions exist as were outlined in Section 4.2 except for the presence of a gravity field about 1/6 of that found on Earth. Also there is the possibility of weld contamination by lunar dust. Although the sunlight will not vary cyclically as it does when in certain Earth orbits, there will still be a large temperature differential between lighted and shaded areas. [36]

Once Mars has been visited by humans, a similar progression of scientific expansion may occur. The experience of building remote permanent structures on the Moon can be applied to Mars. And similarly, the unique environment of Mars will need to be considered when designing welding systems for martian construction.





### 4.3.2 Repair and Maintenance

Over the design life of all space platforms, there is always the possibility of mishaps which result in structural damage. Possible mishaps might include meteorite penetration, satellite or vehicle collisions, or accidental overload of structural members. There are also on-board components expected to need replacement that are not orbital replacement units (ORUs), such as the Space Station Freedom valves discussed in section 3.3.3. It is therefore essential to have the capability to perform limited maintenance and repair jobs to ensure that operational missions can be completed.

However, welding cannot be performed on some materials used in space, such as composites and other non-metal materials. For example, many space structures have composite panels composed of thin facesheets that sandwich honeycomb material. Repairing such panels can be difficult or impossible with welding alone.

Some possible weld repair jobs might include stud welding, patch repairs, or replacement/reinforcement of portions of structural members. If bolting or anchoring structural material together is necessary (due to material limitations), stud welding can be performed to attach a threaded bolt or some other form of secure mechanical anchoring device. Patch repairs might be necessary if meteorites or space debris create a hole or divot in a structural member or plate. Although meteor shields are designed to provide protection



against such mishaps, the damage from large enough objects can be more extensive than allowed for by the design. The hole can be patched and welding can be performed to ensure airtight integrity if there is a breach, or the possibility of one, in the pressure hull. Figure 4.8 shows three typical methods of patch repairs for a hole in a structural member.

Cutting may be required for repair jobs to replace or reinforce structural members. When a portion of a structural member needs to be replaced, removing the entire member may be difficult or impossible. The damaged portion can be cut out and a new piece spliced in. When reinforcing structural members the reinforcement piece may need to be custom cut, if the correct shape cannot be found from the available selection of scrap materials.

Such repairs can be conducted on the space station, the space shuttle, satellites, or any space platform if the proper tools are available. If the space platform has a nuclear reactor on board and the area of repair has unacceptably high radiation levels for EVA, telerobotic manipulation of the repair task could prove to be one feasible solution.



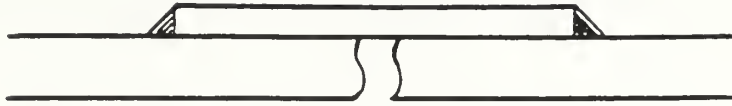

a. Attach a patch by lap welding



b. Butt weld an insert plate



c. Stud weld bolts on the structure and then securely fasten the cover plate work holes by nuts

Figure 4.8 Three typical methods for placing a patch plate over a damaged structural member of a space station [57]



## 4.4 Joint and Surface Preparation

The first step of the welding fabrication process involves the preparation of the joint and the surfaces to be welded. Preparation can be subdivided into:

1. Joint design, cutting, and forming
2. Surface preparation (if needed)
3. Joint alignment, fit-up, and assembly to hold the pieces in place for welding

1. Joint design, cutting, and forming. The simplest solution to preparing the joint is to prefabricate the pieces on Earth so that only assembly is needed prior to welding. It would be inefficient to launch into space all the equipment needed to adequately form some joints. On the other hand, it may be necessary to cut and form the joints in space for repairs or for materials that have been created in space, on the Moon, or on other planets.

For joint geometries created in space, the design should be simple and the production of parts accurate. Simpler joints should require fewer manipulations and therefore speed up the process. Accurate production of components is one strength that automation has over human machinists. When automation is used for joint production in space, the human operator ultimately decides on the joint design. The operator will choose the design, or it may be





preselected by earth-bound engineers. The operator must then convey to the machine how to achieve the goal of production.

To cut metallic materials in space, adequate tools are needed. For thin materials, mechanical cutting could be performed by using a diamond/corundum bladed rotary motorized tool. Thicker materials may require thermal cutting devices such as welding torches, electron beams, or lasers. Ideally, a versatile tool could be designed to cut various materials of different thicknesses. The Soviet's URI electron beam welding tool is a good example.

After cutting, forming the correct joint geometry may be needed. After making a straight orthogonal cut, no other adjustments of the geometry may be needed. In fact, using such plates in a joint design will greatly simplify this step of the fabrication process. If a bevel or some other alteration of the geometry is required, then some form of machining tool will be needed to cut or grind the edge to the desired geometry.

2. Surface preparation. After cutting the material, there may be rough or uneven surfaces, especially if thermal devices were used. In microgravity, drops of molten material tend to cling to the cut's edges rather than fall away, causing a rippled edge as the metal cools. A machining tool can grind down the undulations to provide an adequate surface for fit-up and welding. Even after mechanical cuts, larger than desired burrs may remain that need to be removed.

The welding cold welding process requires special surface preparation to



create effective joints. Impurities and contaminants should be removed from the surfaces to be joined so that more molecular bonds can be created. On earth, oxidation layers will form immediately due to the atmosphere. Once the layers are removed in a vacuum, they will not reform and the metals will bond together when adequate pressure is applied.

3. Joint alignment, fit-up, and assembly to hold the pieces in place for welding. Regardless of how the pieces are formed and the surfaces prepared, the joint must be assembled and the pieces aligned accurately to ensure that the final desired geometry is obtained after welding. Mechanical devices, tack welding, a robotic manipulator, or even a human could hold the pieces in place.

Structural assembly in space using EVA has been proven by the EASE and ACCESS experiments performed on the space shuttle (STS-61B). Although these experiments focused on evaluating astronaut EVA, some of the lessons learned can be applied to automated or semi-automated assembly. For the ACCESS experiment, an assembly fixture with guide rails provided a frame on which the nine members of each structural bay could be assembled. Up to ten bays were constructed to form a truss. Figure 4.9 depicts the assembly fixture mounted on the support structure in the shuttle's payload bay. The guide rails equaled the length of two structural bays, so after one bay was built in the lower half of the assembly fixture, the truss could be slid to the top half of the fixture to accommodate the construction of the next bay.

The ACCESS experiment's assembly fixture is one example of how a



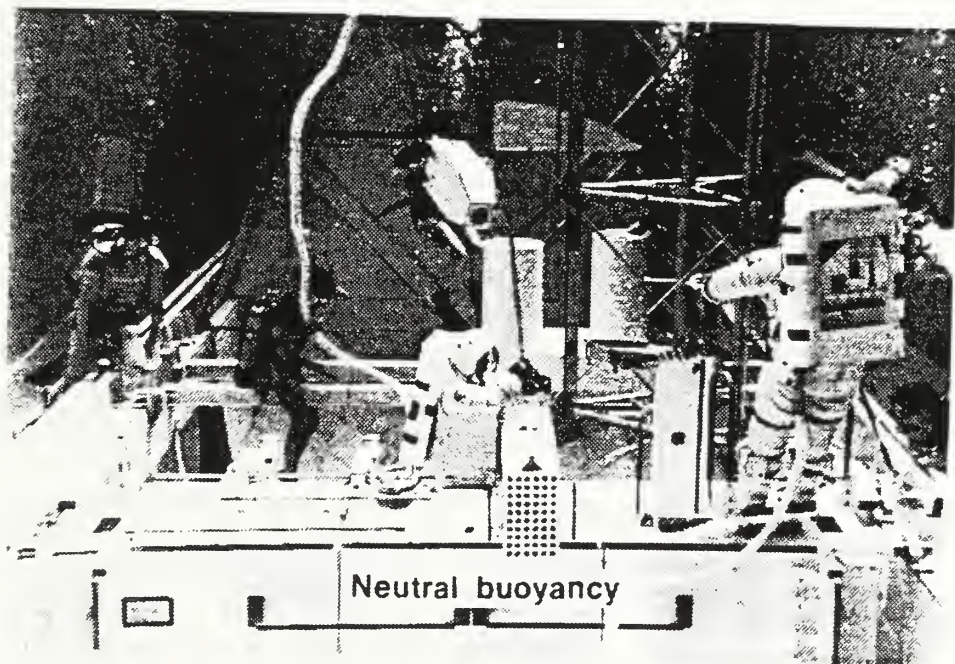
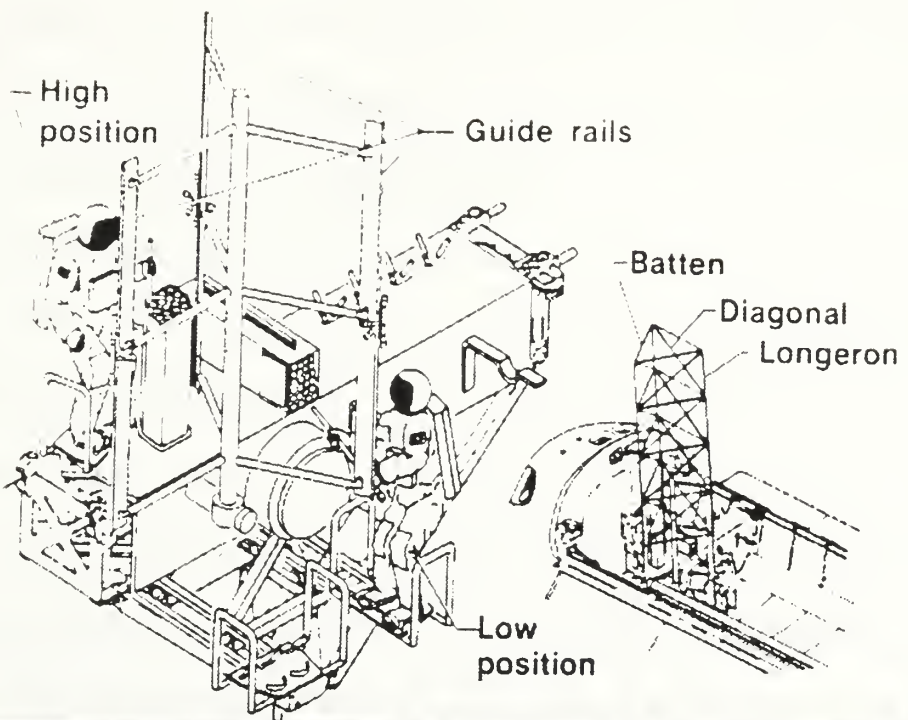

Figure 4.9 ACCESS experiment's assembly fixture [33]



mechanical structure can be used to assist in the assembly of space structures. Similar fixtures can be used to help in the assembly of multiple structures in an assembly line fashion. To minimize the number of fixtures needed, joints should be standardized as much as possible.

Another method of mechanical joint alignment is to design the structural member with mechanical interlocks for ease of assembly and stability of the joint during the welding process. Figure 4.6 shows an example of such a connector design. To hold pieces together temporarily for welding, clamps might be used. They should be designed to engage and release quickly and easily. Clamps might also need harnesses to prevent them from floating away.

There is also the possibility of using a manipulator to hold the pieces in place. This would imply having more than one manipulator or even more than one robot at the same worksite. Astronaut EVA could also be used to position pieces properly. The McDonnell Douglas Space Systems Company has performed neutral buoyancy testing for space vehicle construction using both astronaut EVA and telerobotic devices. In 1989, testing was performed on simulated propellant tank farms and more recently on an aerobrake structure. [8] Figure 4.10 shows an example of the cooperation that can be achieved when both astronauts and telerobots are used for assembly tasks.

Tack welding is another method of temporarily holding pieces in place and is commonly used during fabrication. Tack welding is a good method of temporarily supporting heavy metal pieces and keeping the hands free during





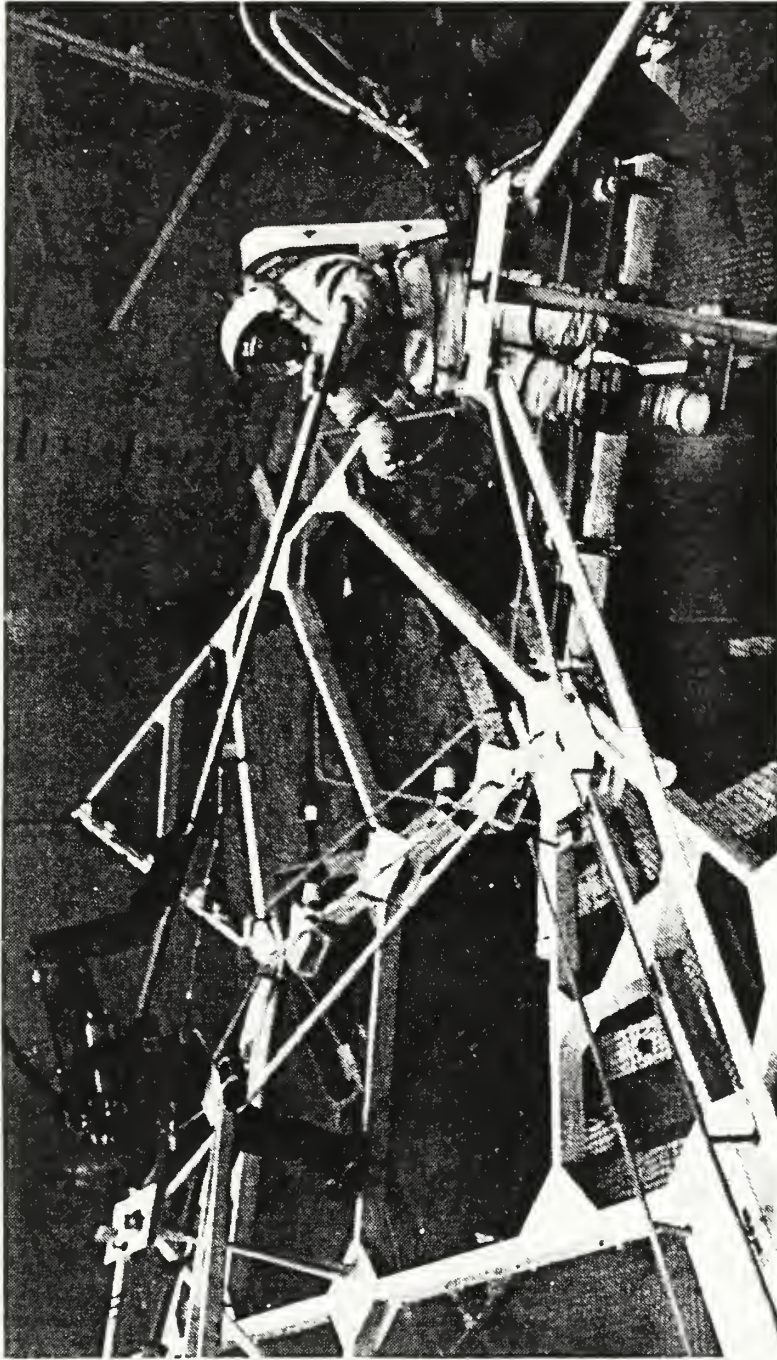

Figure 4.10 EVA and telerobotic cooperation during aerobrake assembly testing in neutral buoyancy [8]



welding. There still exists the problem of properly positioning the pieces prior to tack welding. Tack welding could be easily accomplished by astronauts in EVA without having to worry about the quality of the weld. Then later, a telerobot could finish the welding with a higher degree of quality.

#### **4.5 Welding Processes**

Of the many welding processes that exist, only a few have been seriously studied for use in space. Most have been considered under conditions simulating space, such as in vacuum, in parabolic flight, or both. This section will briefly describe the welding processes most seriously considered for use in space.

1. Arc Welding. (specifically, Gas Metal Arc Welding (GMAW), Plasma Arc Welding (PAW), and Gas Tungsten Arc Welding (GTAW).) GMAW is a gas shielded-arc welding process in which the weld is created by an electric arc formed between a consumable electrode and the workpiece. The electrode is in the form of a filler wire that is mechanically driven into the weld zone. The shielding gas is usually argon or helium since they are inert. The metal is transferred to the workpiece in globular drops or a spray of extremely fine droplets, depending on the electrode current density. The amount of electrode



current density depends on the electrode diameter and material. In the spray transfer mode, the arc column is a well defined cone-shaped core within which the metal transfers to the workpiece. The transfer of metal through this arc column has a higher heat transfer rate than is obtained in the GTAW process, resulting in faster welding rates. Short circuiting-type transfer can be achieved by employing lower currents and voltages. This type of transfer results in a very stable low-energy heat input ideal for welding light materials. Some of the parameters typically adjusted on the equipment by the operator include the wire speed feed, arc length, arc voltage and current, and gas and cooling water rates. A clamp attached to the workpiece completes the circuit for the arc.

Some results of GMAW performed on the Soyuz-6 include:

- At low current, molten drops grew large and remained attached to the electrode for a long period of time.
- Increasing the current increased the electromagnetic pinch effect
- Stable metal transfer was achieved when using the short circuit technique or impressed current.
- Weld beads bulged slightly in the center due to surface tension, resulting in decreased weld penetration.
- When welding in a vacuum, it was possible to achieve a stable arc in the vapor of the electrode material.



The PAW process is valued for its ability to produce a hotter, more concentrated, and more controllable arc. The "plasma" is a hot ionized conducting gas that is turned into a jet when sent through a nozzle.

Advantages of the constricted arc nozzles over the gas shielded-arcs include flame stability and more concentrated power, making the plasma jet very effective at high speed cutting. Plasma arcs have been used for cutting, coating, weld surfacing, and welding.

Some results of PAW performed on the Soyuz-6 include:

- Arc ignition, arc stability, and focus of anode spot was affected by the amount of vacuum.
- On thin samples, weld formation was similar to those done on Earth, but in space the formation was dominated by surface tension forces.
- Sound welded joints were obtained.
- Some porosity was found along the fusion line in the titanium alloy.
- Arc constriction was difficult when the chamber was vented into space.

The USSR conducted arc spot welding experiments in a vacuum with simulated weightlessness using aircraft. They found that the simulated space conditions had no effect on the process of arc spot welding.

GTAW is similar to GMAW in its use of an inert shielding gas, but the





tungsten electrode is not consumed. If filler material is required, a welding rod can be fed into the weld zone and melted. GTAW can be used on almost all industrial materials and the process is widely used for welding dissimilar metals together.

The robotic welding industry has vast and constantly increasing experience in arc welding. Second only to resistance welding, robotic arc welding has been performed for many years. The use of sensors for seam tracking and adaptive control has created new opportunities for arc welding applications. The GMAW process has been predominantly used for robotic welding, although the GTAW process is now being used more often. Robotic PAW has just recently come to the attention of the robotic industry for integration. Precise control of the weld puddle at high traversing speeds with precise joint fit-up is required for PAW to produce a good quality weld joint. For these reasons, PAW has not been incorporated as quickly into the robotic industry as GMAW and GTAW. [45]

Since there has been much experience with robotic arc welding, it is a good candidate for developing automated welding systems in space. In the robotic industry a vast amount of experience has been accumulated in the areas of manipulator design, robot controllers and software, robotic welding positioners (for part positioning), welding process equipment, and weld seam tracking. Of course, research is needed for adapting such welding systems to the space environment and optimizing the systems weight and cost for a



required level of productivity.

The Soviet space program developed an arc welding process for space use called the hot hollow cathode welding process. It produces a stable arc in a wide range of vacuum with an arc gap from 2 to 25 millimeters. The process is safer than EBW due to lower voltage (15 to 25 Volts), lack of x-rays, and simplicity of the equipment. The welds formed are more similar to EB welds in width and depth of penetration than they are to arc welds. The process is most similar to GTAW since the nonconsumable cathode is made of tungsten or tantalum. Figure 4.11 is a diagram of the welding process. To help stabilize the arc, the electrode is separated into two pieces, an auxiliary electrode and the hollow cathode. A gap between the two increases the discharge excitation. [66] Figure 4.12 shows the prototype of the manual hollow cathode welding torch and power supply yet to be tested in space.

2. Stud Welding. This is an application of the arc welding process that uses an arc to heat the workpiece and the stud before joining them together under pressure. Capacitor-discharge stud welding uses a capacitor to store energy that supplies the arc power. It requires less power and is most applicable for welding smaller diameter studs to thin sheets. [26] This is ideally suited for use in space structures since they will largely be made of thin sheets of light metal. Additionally, in low-gravity the loading conditions are much smaller than they are on Earth. For heavier structures, regular stud welding with D.C. power



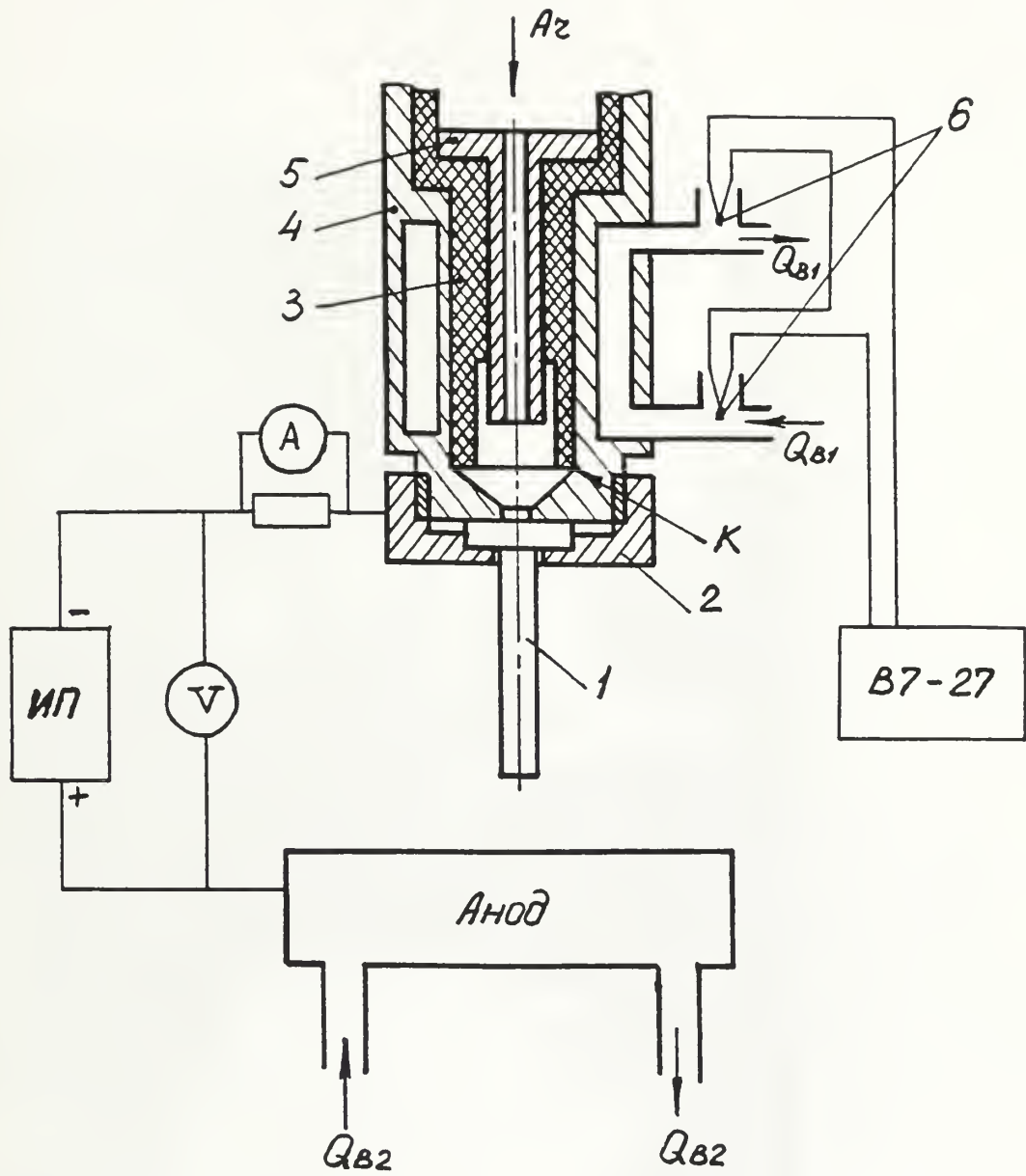

Figure 4.11 Hot hollow cathode welding scheme [66]

1 - cathode; 2 - tip; 3 - insulator; 4 - body torch;  
 5 - subsidiary electrode; 6 - differential thermocouples;  
 K - test point.



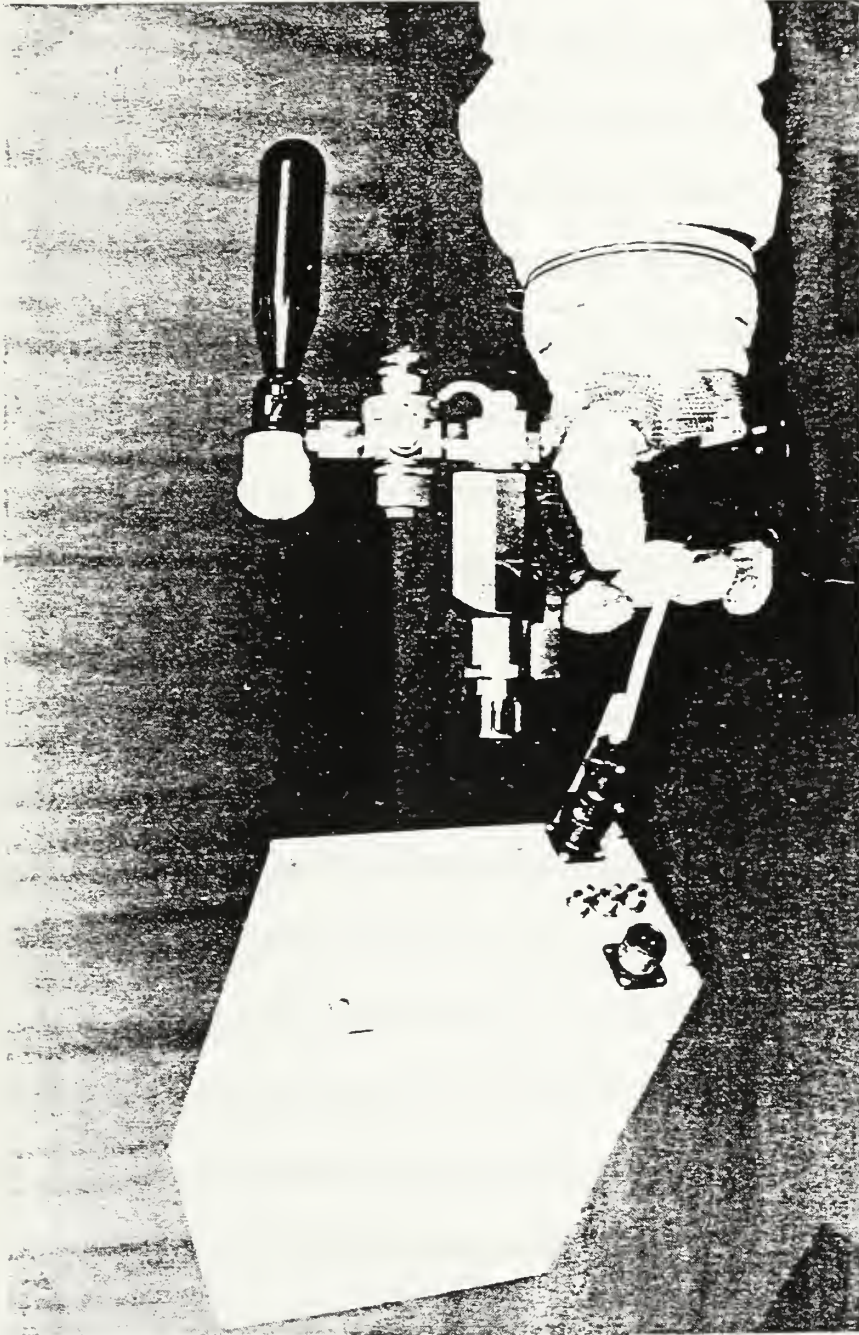

Figure 4.12 Prototype of torch and power supply for manual hollow cathode welding in space [66]





sources similar to that of GMAW can be used.

The stud provides an anchor point for attaching other parts with mechanical fasteners. Stud welding tools have been designed and successfully tested for remote operation. They can easily be designed to be completely automated. To operate such tools little welding skill is required beyond the ability to properly position the tool and pull the trigger. All other operations needed to ensure the quality of the weld can be performed automatically. Such a tool can be used in space with minimal research and development. An automated stud welding system could be developed that operates either by a remote manipulator or by an astronaut with no welding skills. However, it is not a versatile tool so it is not applicable to other welding tasks.

3. Electron Beam Welding. In electron beam welding (EBW), heat for the weld is produced by a concentrated beam composed primarily of high-velocity electrons. The process is conducted in a vacuum for the most efficient transfer of the electrons' kinetic energy to the workpiece. The space environment therefore provides a natural vacuum for this process. It would not be used for welding inside the spacecraft since vacuum chambers would be needed, which are expensive and incur a severe weight penalty.

An electron beam gun creates the accelerated electrons and is composed of an emitter, called the filament or cathode, a grid cup, an anode, and focusing and deflection coils. The emitter, usually made of tungsten,



releases electrons when heated to a high temperature, causing thermionic emission. The electrons are then attracted to the positive charge of the anode, which has a hole in its center. The electrons that come through the anode hole are then focused by the magnetic forces of the focusing coil. The beam can then be deflected by the magnetic forces of the deflection coils. [26]

One major advantage of EBW over arc welding is its tremendous weld penetration. The depth-to-width ratio can exceed 20:1. The electron beam's heat input is controlled by beam current, accelerating voltage, beam diameter at or within the workpiece, and the welding speed. The current and the voltage may be adjustable if the equipment is so designed. The beam spot size is determined by the beam focus and the distance between the gun and the workpiece. The travel speed should be such that penetration is achieved for a given thickness of material.

The beam's current is normally less than 1 Ampere, and the accelerating voltage is on the order of thousands of volts. Power usually ranges from a few kilowatts to 50 kilowatts. When such high voltages are used the astronaut's safety is a real concern. Not only does the high voltage itself create danger, but x-ray radiation is produced, which can be harmful in extreme doses and at the very least decreases the astronaut's radiation exposure limit. Soft x-rays are produced at accelerating voltages less than 20 kilovolts and hard x-rays are produced with voltages greater than 20 kilovolts. This problem can be eliminated by distancing the astronaut from the worksite and using automation



to perform the task. To reduce the radiation danger, shielding could be used, which creates a sizable weight penalty.

On board Skylab, a metals melting experiment, known as M 551, used an electron beam to melt samples of aluminum alloy (22019), stainless steel (321), and thoria dispersed nickel. The samples were disk-shaped and attached to an electric motor assembly. The samples were rotated while keeping the 1.5 millimeter electron beam stationary. The beam current, voltage, and traversing speed was 50 to 80 milliamperes, 20 kilovolts, and 58 meters per hour respectively. [57] Each sample had some regions of cutting, partial and full penetration welds, and a large molten pool. Findings of the experiment were as follows:

- The feasibility of performing electron beam welding, cutting, and melting in microgravity conditions was proven.
- The Skylab samples showed that the grain shapes were larger and more elongated than the ground-based specimens. This indicates a major difference in heat convection during solidification of metals.
- The Skylab specimens had more symmetrical sub-grain patterns, while ground-based specimens showed orientation with the solidification front.



- The Skylab samples had cracks or hot tears that were not observed in the ground based samples.

The results of the Soyuz-6 EBW experiments on aluminum alloy, titanium alloy, and stainless steel include:

- The weld shape and degree of penetration were similar to that of ground based samples.

- Sound welded joints were achieved using all materials.

- There was a slight increase in the porosity of the aluminum alloy sample, most likely because of the lack of a significant gravity gradient to produce buoyancy forces.

- Electron beam cutting of all materials was proven. [57]

The Soviet space program has compared EBW, GMAW, and PAW and has concluded that the electron beam should be used due primarily to its versatility and inherent energy effectiveness. Electron beam equipment can be designed to perform several processes: welding, cutting, heating, brazing, and coating. These processes are illustrated in Figure 4.13. Figure 4.14 shows





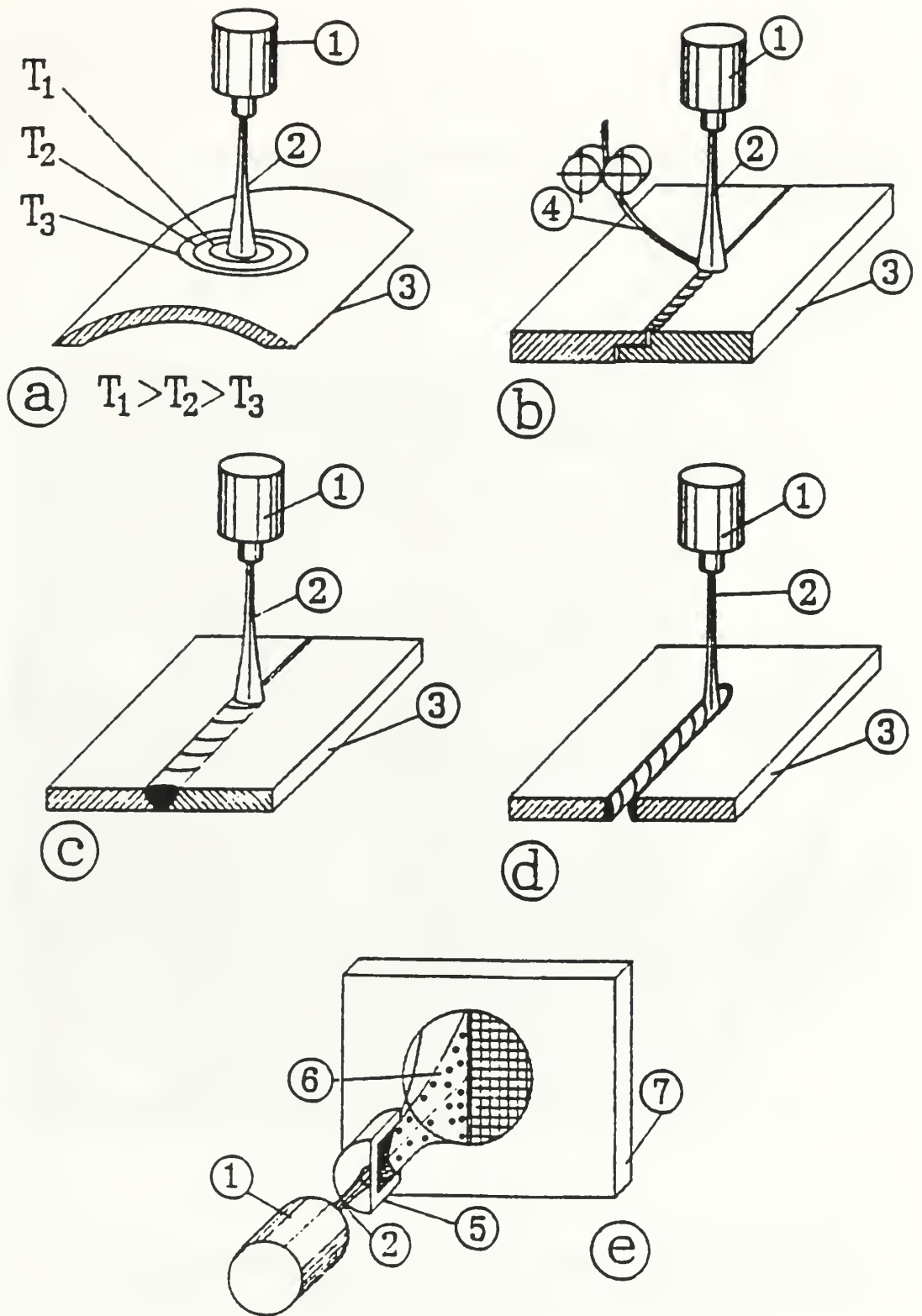

Figure 4.13 Electron beam welding processes [48]

(a - heating; b - brazing; c - welding; d - cutting; e - coating).

1 - electron gun; 2 - electron beam; 3 - workpiece being treated; 4 - filler wire; 5 - crucible with evaporating material; 6 - vapour stream; 7 - substrate



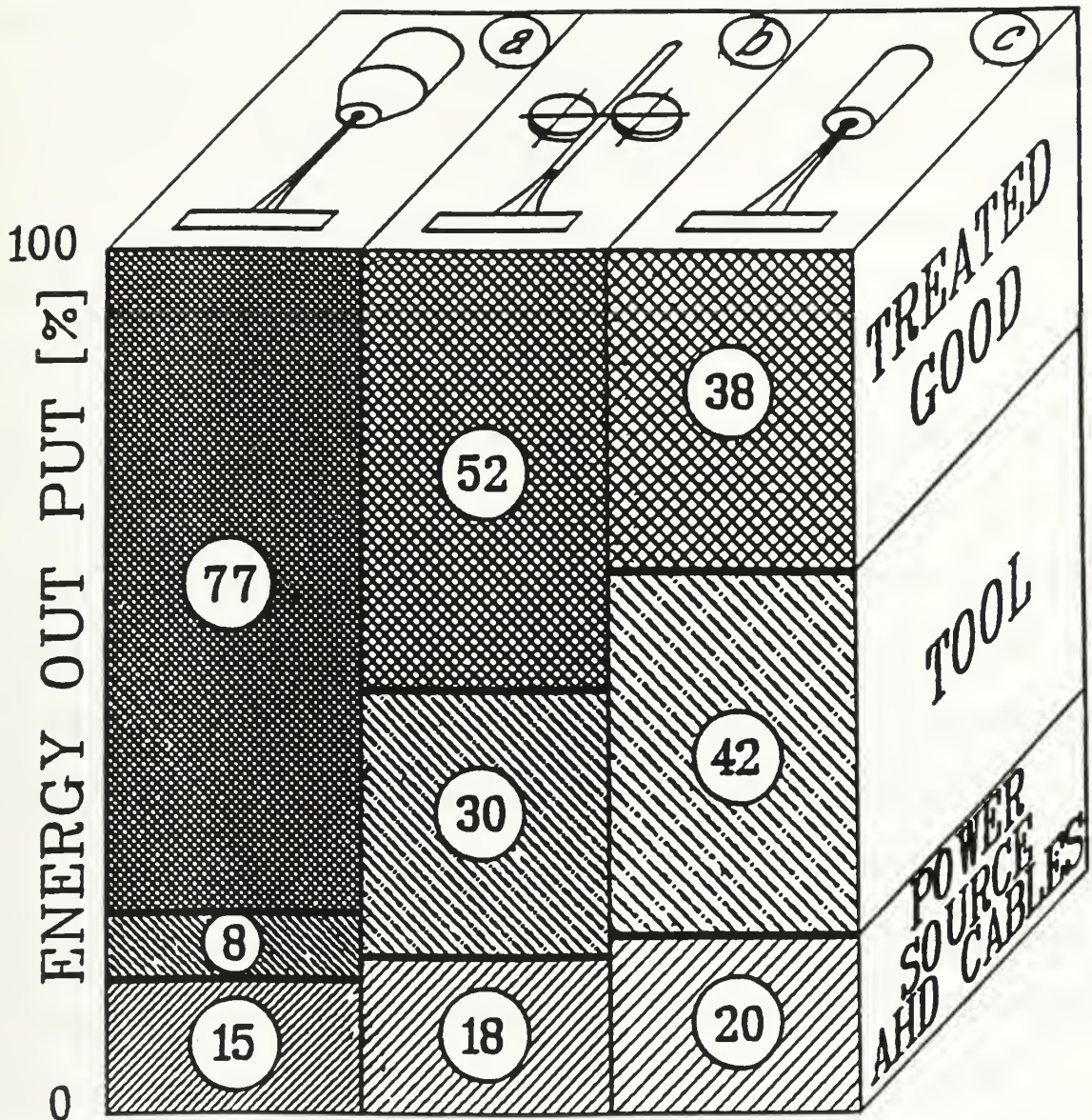

Figure 4.14 Energy effectiveness comparison between EBW, GMAW, and PAW [48]



how the EBW's energy effectiveness exceeds that of GMAW and PAW. Energy effectiveness here is defined as the proportion of the total energy transferred to the workpiece rather than being dissipated in the tool, power source, or cables. [48] For these reasons, versatile EBW tools have been developed and proven for use in space. Such tools can be used by either astronauts, automated machines, or teleoperated manipulators.

4. Laser Welding. This is the use of a tightly focused beam of electromagnetic energy as a heat source to fuse materials together. Like EBW, laser welding needs neither shielding gas nor the application of pressure. And like electron beams, laser beams can be used for several processes such as welding, cutting, heat treatment, brazing, soldering, drilling, and marking. Even higher penetration ratios can be achieved with lasers than electron beams.

There are many different types of laser systems, classified as either solid-state or gas, and having different modes of operation, either continuous or pulsed. Laser welding systems need specialized equipment such as the beam source power supply, cooling system, gas supply, and a control system.

Automatic control of the beam is normally required due to speed and precision tolerance requirements. The accuracy of movement must be very precise as compared to other forms of automated welding. Fiber optic cables requiring a relatively low amount of power can be used to direct the beam. Lasers can also be used to cut non-metal materials. The energy efficiency of



laser beam welding equipment is relatively low, ranging from 5 to 10 percent. One difficulty is that not just power input but also the material's thermal conductivity and metal vaporization on the workpiece's surface affect the speed and weld penetration. Such vaporization can create a plasma above the workpiece that absorbs energy and can block the beam and reduce melting.

[26]

5. Resistance Welding. This form of welding uses the electrical resistance of the joint together with pressure to create a bond. Heat is produced by passing a high current (up to 100,000 Amps) through the joint that provides a point of maximum resistance. Low voltages are enough to heat the metal to a plastic state. Mechanical pressure on both sides of the joint expels contaminants, prevents shrinkage cavities, and refines the grain structure of the weld. This form of welding is limited to joint geometries in which two pieces of metal overlap, such as a lap joint. One of the most popular forms of resistance welding is spot welding. The pressure contact points are the same points at which the current is conducted, the electrode tips.

Resistance welding is the most predominant form of welding in the robotic welding industry. The conventional resistance spot welding process is most common. Therefore, a wealth of experience and information is available on robotic spot welding. Many robotic arm configurations have been developed that allow greater flexibility and accessibility in positioning the welding gun on





the workpiece. New welding equipment is constantly being developed such as automatic tool changing systems, welding guns with integrated transformers, and microprocessor-based welding controls. [45]

6. Brazing. To join metals using a molten filler with a liquidus above 840 F and less than the solidus of the base metal defines a group of welding processes known as brazing. (If the liquidus is less than or equal to 840 F, the process is called soldering.) [26] There are many forms of brazing, each of them using a different method of heat application. The filler metal is normally preplaced or fed into the joint as it is heated. The joints are usually thin and have a large surface contact area. Once the filler metal has been melted, it flows through the joint clearances by capillary action. Since surface tension forces usually dominate in the absence of gravity, the capillary action increases and becomes more effective when brazing.

A brazing experiment, M552, was conducted on board Skylab. The experiment used thermochemical brazing to demonstrate the feasibility of brazing for repair and maintenance in space. Exothermic, or thermochemical, brazing uses the heat of specific chemical reactions to melt the filler metal. The M552 experiment brazed together a stainless steel tube and sleeve using a filler alloy containing 71.8% Ag, 28% Cu, and 0.2% Li. The exothermic material was covered by a layer of aluminum oxide to eliminate the need for gaseous oxygen and to ensure that the reaction was contained. Four gaps were brazed,



ranging from 0 to 0.75 millimeters with one of the gaps being tapered. [57] The following results were observed:

- The wetting and spreading characteristics of the brazed samples were superior to those created on Earth, which resulted in better filling of the gaps.
- The Skylab joints had fewer defects and less porosity than ground-based joints, showing that quality was increased.
- There seems to be no upper limit to the size of gaps that can be brazed in space, therefore joints with large fit-up tolerances can be brazed.
- Brazing can compete with welding for many space applications where only welding would normally be considered.

7. Solar Welding. This form of welding uses the direct energy of focused sunlight to create heat for melting metal. It may be the most energy efficient method of welding in space due to the availability of solar energy, resulting in a high specific power for the process. Ground-based solar brazing experiments were conducted by the Soviets Union in the early 1970s. Brazing conducted in a vacuum chamber with solar reflectors provided some promising results. Similar studies have been conducted in the United States on the feasibility of



using solar concentrators for processing materials in space. [57] The solar concentrators must be of sufficient dimensions to provide enough thermal energy and a thermal environment that is conducive to the process. The concentrators would have to track the sun during orbital transition and would not be useable on the dark side of an orbit.

8. Friction Welding. In this process heat is produced by the mechanical friction between two pieces of metal. The friction is usually produced by rotating one piece and then forcing the joint together to provide adequate normal contact force. Joint geometry is restricted to one flat piece and one piece that is a body of revolution. One possible use for friction welding is to apply studs to metal sheets. Automation of this process would be relatively simple compared to other forms of welding. [39]

9. Ultrasonic Welding. Similar to friction welding in concept, this form of welding joins materials by the local application of high-frequency vibratory energy as the workpieces are held together under pressure. Instead of rotary friction, linear friction is produced by an ultrasonic tip or electrode clamped against the workpieces and made to oscillate parallel to the direction of the weld. The process is restricted to extremely thin materials such as foil.

10. Diffusion Bonding. Here a bond is created by the application of pressure at



elevated temperatures for an extended period of time. An extremely close tolerance joint preparation is required, and a vacuum or an inert atmosphere is used. A temperature one-half that of the material's melting point has produced successful welds on some materials. To use this process for finished machine parts, the applied pressure should be no more than enough to produce 5% deformation of the material. This process is often used on materials or joint geometries that are difficult or impossible to create by other methods. Since joining time is usually an important factor, this process will probably not be used extensively in space. Also, the bonding mechanism is not yet fully understood.

[57]

11. Explosion Welding. A controlled detonation creates a high relative velocity between two materials that bonds them together when they collide. Heat is created mostly by the explosive shock wave and by plastic deformation upon collision. This process is useful for joining two dissimilar metals that are difficult to weld using other processes. The most widely used application is the joining of flat plates. Explosives are placed on opposite sides of the plates. The explosion can be contained within an enclosure designed to direct the explosive pressure toward the bond area. [57]

12. Cold Welding. In this form of bonding, high pressures at room temperature form welds with substantial deformation of the materials. The interface between





the materials are kept extremely clean in order to obtain good bonds between the two pieces without an adverse strength reduction due to contamination. For this reason it is preferred to conduct cold welding inside a vacuum. This method is effective at joining dissimilar materials.

13. Ion Beam Welding. If ion thruster engines are used for spacecraft propulsion, the ion beam sources could have potential applications for space processing and fabrication. Such a heat source could possibly be useful for welding in space. This form of welding is an unproven concept with no experimental verification. [57]

#### **4.6 Weld Quality Evaluation**

For each step of welding fabrication, the quality of the final product must be evaluated. During the joint preparation, the weld joint geometry and gap sizes between the parts should be acceptable. During welding itself, weld parameters can be sensed to ensure they are within acceptable limits. After welding is completed, inspections are conducted to ensure the welded joint is within design specifications.

Mechanical tests can be performed to qualify welding procedures, welders, welding processes, and to determine if electrodes and filler metals



meet the proper requirements. Such tests are called destructive tests because the weld or joint is destroyed in making the test specimen. Destructive testing is not likely to be conducted on-orbit but rather to qualify welding tests and processes under simulated space conditions.

#### **4.6.1 Non-Destructive Tests**

Many non-destructive tests (NDTs) have been developed to detect flaws or discontinuities in welded joints without decreasing their structural integrity. The most widely used NDT methods include visual, dye penetrant, ultrasonic, radiographic, and magnetic particle testing. Of these methods, dye penetrant and magnetic particle testing would not be feasible in space due to the effect of microgravity. Inspections are usually performed by qualified welding inspectors but it is becoming possible to automate the inspection process with the current state of the art technology.

Radiographic examination is a slow and expensive method using x-ray or gamma ray radiation to record defects inside the weld rather than on its surface. Access is necessary on both sides of the weld since a radioactive source is placed on one side and the radiographic film on the other. This method can be inherently used if real-time radiographic sensing is incorporated into the process. For welding on-orbit, this method may not be very attractive



due to the weight penalty imposed by the equipment.

Ultrasonic examination involves the use of mechanical vibrations similar to sound waves but at a higher frequency. A transducer in contact with the weld transmits and receives a beam of ultrasonic energy to find surface and subsurface discontinuities. A thin film of fluid, usually oil, is present between the transducer and the specimen to enhance the ultrasonic transmissions. The electronic equipment for ultrasonic testing is usually small and portable. [26] This method of testing is used on a completed weld and requires contact with it. Two-dimensional holographic imaging of weld defects is also possible as a visualization tool to help locate and determine their size. [47]

Other methods of NDT such as eddy current inspection and holographic interferometry are not yet as popular as the methods described above. The eddy current inspection method uses the A.C. magnetic field of a coil to induce eddy currents in a weld specimen. Defects can be identified by analyzing the eddy current field. Crack sizes can be determined by using a multifrequency approach that helps to suppress signal disturbances. [18] Eddy current inspection is not as effective with non-ferromagnetic materials, such as aluminum, and therefore may have limited use on spacecraft.

Holographic interferometry involves visual observation of an interference pattern on the specimen that can reveal defects and residual stresses. The effectiveness of defect localization depends on the method of loading on the structure. This method of NDT requires no contact. [51]



#### 4.6.1.1 Visual Inspection

Of all the methods described in the previous section, visual inspection is by far the cheapest and the most widely used. Unlike most testing methods, it can be used in all phases of the welding fabrication process, including preparation, in-process, and post-process inspections. One special consideration for monitoring welding in progress is the need to filter the bright welding arc or light so that the viewing area can be seen more clearly. A real-time image enhancing scheme might be employed to help decrease the brightness of some portions of the image while increasing the intensity of darker areas. [61]

For remote welding operations, a camera is normally used by the operator to monitor the process. This camera can be used not only when performing the required tasks, but also to ensure the quality of the final product by visual inspection. The camera can also magnify portions of the weld to inspect tiny cracks and discontinuities. With current fiber-optic technology, cameras can be fit into a very compact volume. Small cameras can inspect welds at very close distances, and can even be used to find microscopic cracks if the proper lenses are used.

The video signal can be fed into multiple terminals, allowing several inspectors to view the same remote welding operation from various locations. In this way, relatively unskilled astronauts in space can be assisted by welding





experts on Earth while welding progresses (give or take a few seconds for the transmission time delay).

#### **4.6.2 Quality Through Automation**

Robotic welding has revolutionized the manufacturing industry by vastly improving the efficiency of mass production lines. Machines are generally better than humans at performing repetitive tasks reliably and accurately. The performance level of automation can be maintained over extended periods of time in situations where humans would rapidly fatigue. For these reasons, once properly established, automated welding has shown considerable quality improvements over manual welding. As trained welders know, good quality welding is a complicated skill that is difficult to learn. This difficulty can be attributed to several reasons, including the simultaneous performance of multiple skills such as joint tracking and welding speed control. Once such skills are automated, the machines' consistency, accuracy and reliability provide weld joints of high quality.



## 4.7 Influence of Welding on Space Structural Design

If and when welding is to be used to join structural members in space, the joints design needs to be considered. Only if the joints are designed correctly will the benefits of welding over other joining processes be realized. Joint designs may vary depending on whether the welding is to be performed manually, semi-automatically, or fully automatically. And if welding is performed automatically, the joint design can vary depending on the sensors employed, if any are used.

It is not intended here to describe the fine details of weld joint design, but to alert the reader to the fact that this must be addressed. For those unfamiliar with the basic types of welds and joints, see Figures 4.15 and 4.16. The fillet weld is the most popular since there is no preparation required and it can be used for almost all types of joints. Groove welds are the second most popular and, depending on the complexity of the groove, normally require preparation to the groove edges. [26]

For automated welding the joints can be designed to minimize manipulations and to allow easy access to the joints when welding. Such design might be based on the size of the manipulator, sensors, and welding tools to be used. Manipulations such as welding inside tight spaces should be avoided. For more complex geometries, more complex manipulations are required. The joints can be designed to increase the tolerance needed for tool



**FILLET**

Most popular of all welds  
(may be single or double)



**PLUG OR SLOT WELD**

Used with prepared holes

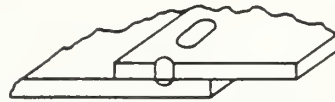

**SPOT OR PROJECTION WELD**

Used without prepared holes  
Use arc or resistance

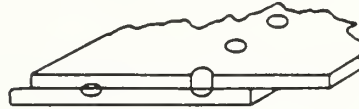

**SEAM WELD**

Continuous—use arc or  
resistance



**GROOVE**

Second most popular—may  
be single or double—has  
many variations

Seven  
types



**BACK OR BACKING WELD**

Bead type back or backing  
welds of single groove welds



**SURFACING WELD**

Surface built up by welding

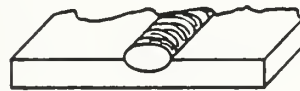

**FLANGE WELD**

Used for light gage metal  
joints

π  
Edge



π  
Corner



**STUD WELD**

Special application  
welding process

⊗  
Stud

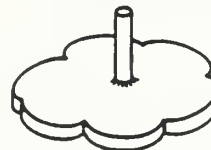

Figure 4.15 Eight basic types of welds [26]







JOINTS	SINGLE FILLET 	DOUBLE FILLET 
BUTT (B)		
CORNER (C)		
TEE (T)		
LAP (L)		
EDGE (E)		

Figure 4.16 Fillet weld used to make the five basic joints [26]



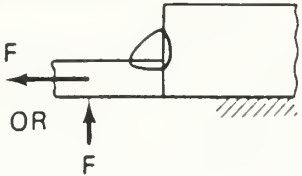
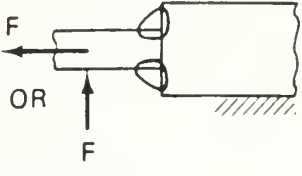
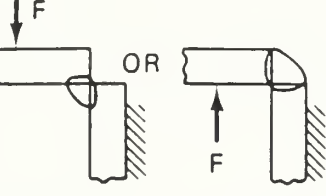
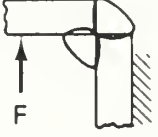
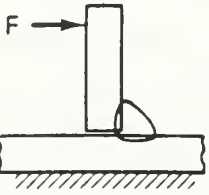
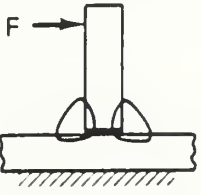
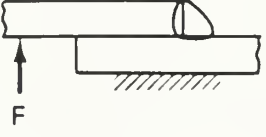
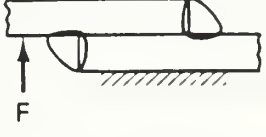
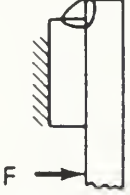

positioning and fit-up variation so that there is less chance of missing the joint and decreasing the weld quality.

Joints for space use should be designed to minimize the amount of mass while ensuring adequate strength. To minimize the joint mass, filler material should not be used if welding methods are available, such as GTAW or EBW, which normally do not require filler material. Fillet welds would be preferable to groove welds since little or no filler is needed for fillet welds, while groove welds require one or more passes to fill the groove. The use of filler material also makes the welding process more complicated since a wire feed mechanism or hand-held consumable electrodes are required. [62]

It will be important to design joints in such a way that the pieces remain stationary once assembled and don't float away prior to or during welding. If the joint is simple, the pieces can be held with one hand (or manipulator) while welding with the other. But a better design might use fasteners, guide pegs, or bumps to ensure good alignment while helping to keep the joint fixed during welding.



## Chapter 5: The Use of Automation for Space Welding

The use of automated welding operations has become common in industry for several reasons. Productivity is increased through higher welding speeds and deposition rates, and less operator fatigue. Consistent, predictable welds have good quality and better appearance. Less operator skill is needed while operator safety is increased.

The use of automation to assist in the task of welding in space should be considered for the same reasons. Manual welding can be done in space, but an astronaut performing EVA will be restricted by time limitations as well as the bulky space suit and gloves. The productivity of the astronaut cannot match that of automation. But for initial space welding jobs, productivity may not be as important as the quality of the final product. Even if the astronaut is a skilled welder on Earth, it is unlikely that he or she can achieve the same performance and quality in a space suit in a space environment.

Separating the astronauts from the worksite increases their safety. If molten slag were to come in contact with the space suit during welding, the resulting holes could certainly be life threatening. The high voltage and x-ray radiation created by EBW equipment can threaten the safety of the astronaut. The evolution of EVA itself is considered to be one of the more hazardous duties involving considerable time and expense.



This chapter examines the possible levels of automation, operational modes and scenarios, and potential use of manipulators for space welding.

## **5.1 Levels of Automated Control**

The three broad levels of automated control are manual control, supervisory control, and fully automatic control. For all three forms, the human operator is assumed to have overall control, with the automated machinery performing the actual remote tasks. Figure 5.1 shows the basic concept of remote control in which two computers, remote and local, manage the form of automated control desired by the operator.

Manual control is the direct control of the task by the operator. The operator controls each movement of a manipulator and initiates each step of a process. There may or may not be a computerized link between the operator and the machine. The operator uses sensors to constantly monitor the machine, to ensuring that he is properly controlling it. Even if there is a computer controlled command link between the operator and the machine, the computer can not assume any control of the machine.

In supervisory control, the operator is continually programming and monitoring a computerized, automated system, which performs a task or process. [76] The operator can have direct control but the control functions of



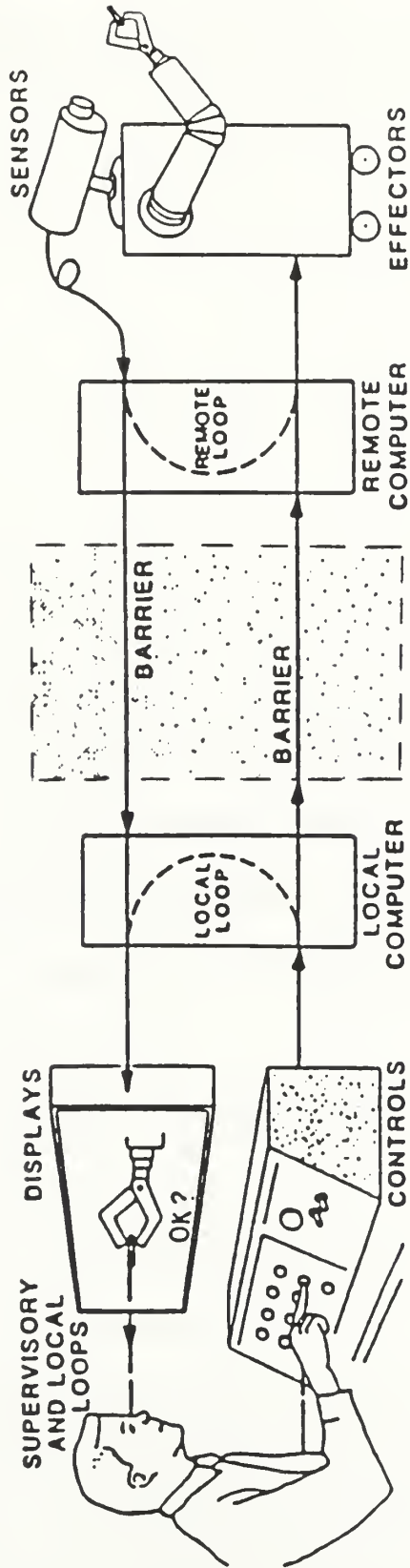

Figure 5.1 Basic concept for remote human-supervised control system [76]





some tasks or subtasks can be delegated to the computer. The computer may assume closed-loop control of part of the system upon the operator's direction. If the computer controls the entire system for any amount of time, this is called fully automatic control. The operator can only observe the data from the sensors and pull the plug if the automation does not perform properly.

Figure 5.2 shows this spectrum of control modes. A given system may be capable of one or more of these modes at the discretion of the operator. For space welding, the ability to shift between the control modes may prove beneficial. For tasks that have not or cannot be programmed into the computer, manual control may be the only way to accomplish the task. On the other hand, if good quality cannot be achieved manually with certain welding processes and/or materials, fully automatic control may be the answer. In some cases, it might be necessary to fully automate the control of some variables and manually control others. For example, the programming may not have taken into account certain variables that the innovative human operator can compensate for.

To illustrate how automation can be used in welding, Figure 5.3 shows a spectrum of machine control methods for GMAW. Note that for remote welding, the human hand would be substituted by the manipulator's gripper. The spectrum of control methods varies from left to right as the machine controls additional welding functions. The automatic (AU) and automated (AD) GMAW methods are both considered to be fully automated, but AU uses open-loop pre-



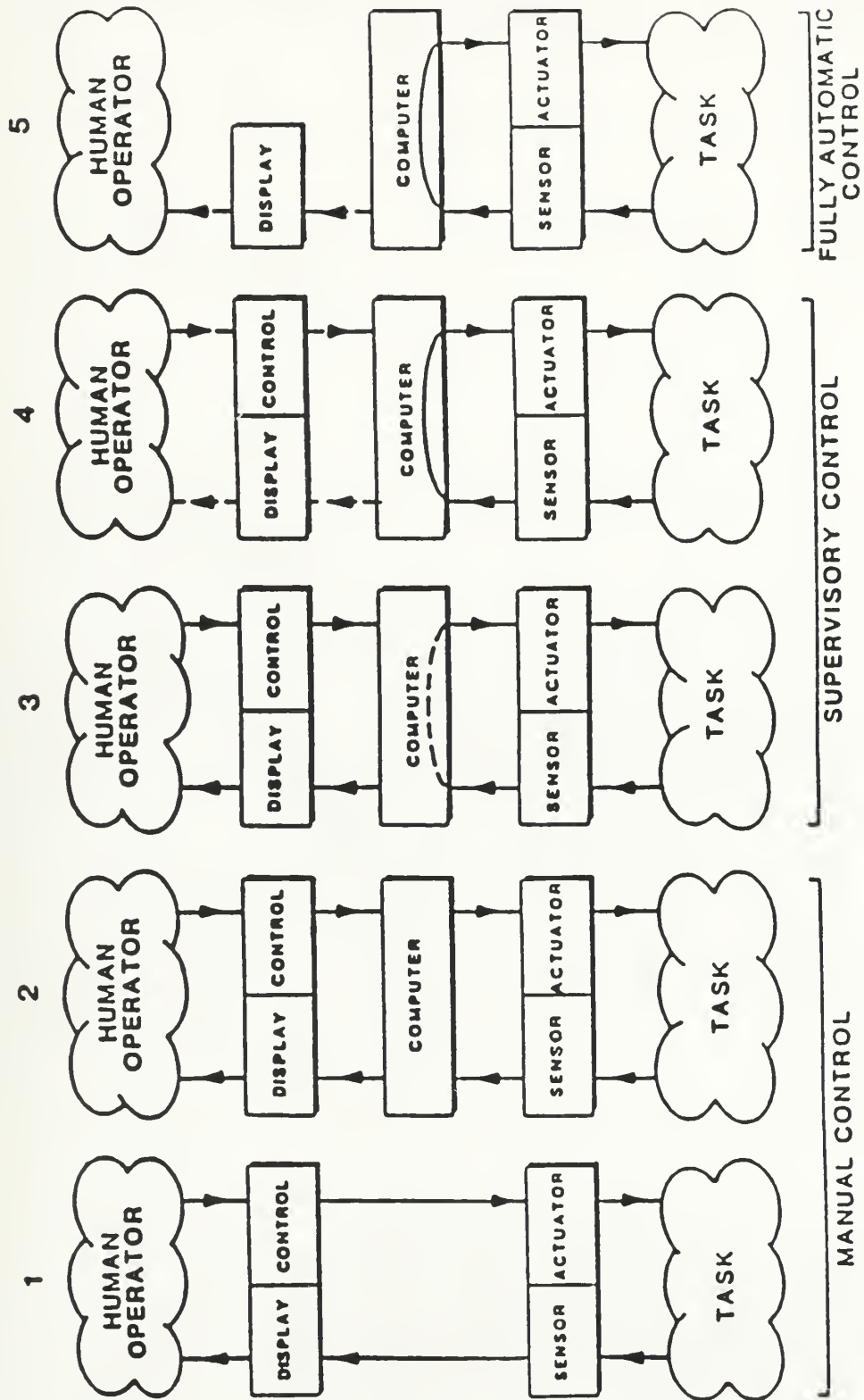

Figure 5.2 The spectrum of control modes [76]



Method of Application Arc Welding Elements/Function	MA Manual (closed loop)	SA Semiautomatic (closed loop)	ME Machine (closed loop)	AU Automatic (open loop)	AD Automated (closed loop)
Starts and maintains the arc	Person	Machine	Machine	Machine	Machine (with sensor)
Feeds the electrode into the arc	Person	Machine	Machine	Machine	Machine
Controls the heat for proper penetration	Person	Person	Machine	Machine	Machine (with sensor)
Moves the arc along the joint (travels)	Person	Person	Machine	Machine	Machine (with sensor)
Guides the arc along the joint	Person	Person	Person	Machine via prearranged path	Machine (with sensor)
Manipulates the torch to direct the arc	Person	Person	Person	Machine	Machine (with sensor)
Corrects the arc to overcome deviations	Person	Person	Person	Does not correct, hence potential weld imperfections	Machine (with sensor)

Figure 5.3 Levels of control for GMAW [26]



programmed control while AD uses closed-loop control with sensors. The typical sensors used for automated welding methods are numerous and will be discussed in Section 5.4.

## **5.2 Operational Control Modes for Space Welding**

"Welding in space" is a generic term that could imply one of many operational modes. Welding can be performed inside or outside a spacecraft. The process control can be local or remote.

Manual welding could be performed by astronaut EVA for jobs outside the spacecraft, but there may be considerable safety and quality disadvantages as discussed at the beginning of this chapter. If an emergency occurs and welding is necessary, quality and safety during welding are lesser concerns and the job should be done any way possible if the welding equipment is available. The astronaut may be delivered to the worksite by one of many methods including the Manned Maneuvering Unit (MMU) or at the end of a general purpose Remote Manipulator System (RMS). If the power needed for the welding equipment is not self-contained, power leads will be needed near the worksite.

It is likely that some repair and maintenance jobs requiring welding will be necessary inside the spacecraft. For example, some of the life support





system valves on Space Station Freedom will need replacing, possibly by cutting them out and welding in new valves. Section 3.3.3 discusses this scenario and Section 4.3.2 addresses welding for repair and maintenance in general. Different welding processes can be used inside the spacecraft where a gaseous atmosphere is present, as opposed to outside where there is none. For example, EBW must have a vacuum and would not work inside the spacecraft, unless it is for some reason evacuated. An enclosure may be needed around the work area so that the spacecraft's atmosphere is not contaminated by metal vapors and byproducts of the welding process.

Remote manipulation of space welding can be conducted with the operator in space or on Earth. If the operator is in space, he or she is not likely to be a skilled welding expert. In this case, there is the need to transport these skills into space. This can be done using an automated welding system, an expert system to assist the astronaut in making key decisions, or both. The welding performed by the astronaut can also be visually monitored by welding experts on Earth who can assist in the fabrication process.

Earth-based operators would most likely be welding experts. Teleoperation from Earth would have to contend with transmission signal delays, which can cause instability of control signal feedback (such as is needed for conventional force feedback). For the space-ground communication link used in the space station program, the round-trip time delay can be up to three seconds. Figure 5.4 shows a schematic of the space-ground



communication link. Most of the delay is due to signal processing rather than transmission delay time. Signals travel through the Space Station Control Center to the space station via the White Sands Ground Terminal and the Tracking and Data Relay Satellite System. As shown in Figure 5.4, the processing time on the ground and in the station takes about 2.42 seconds whereas transmission time takes about 0.48 second. [75]

When time delays are present in teleoperated control, the operator can try a "move-and-wait" control strategy, but this technique is less time efficient, more prone to error, and fatiguing to the operator. Other strategies for dealing with time delays include the use of predictor displays, predictive force reflection, and supervisory control. Predictor displays show in real time what the manipulator is going to do by superimposing an image on the viewing screen. [76] Figure 5.5 shows a diagram of a predictor display system. Figure 5.6 is a photo of what such a display might look like. The image in the center is created with computer graphics, and the real arm is shown slightly to the right of the image.

Predictive force reflection is similar to using predictor displays, except that a force is felt by the operator when the manipulator collides with an object. Successful use of predictive force reflection depends on a good world model of the environment around the manipulator. [24] The model predicts when a collision is imminent and creates a force to signal this information to the operator before it actually happens.



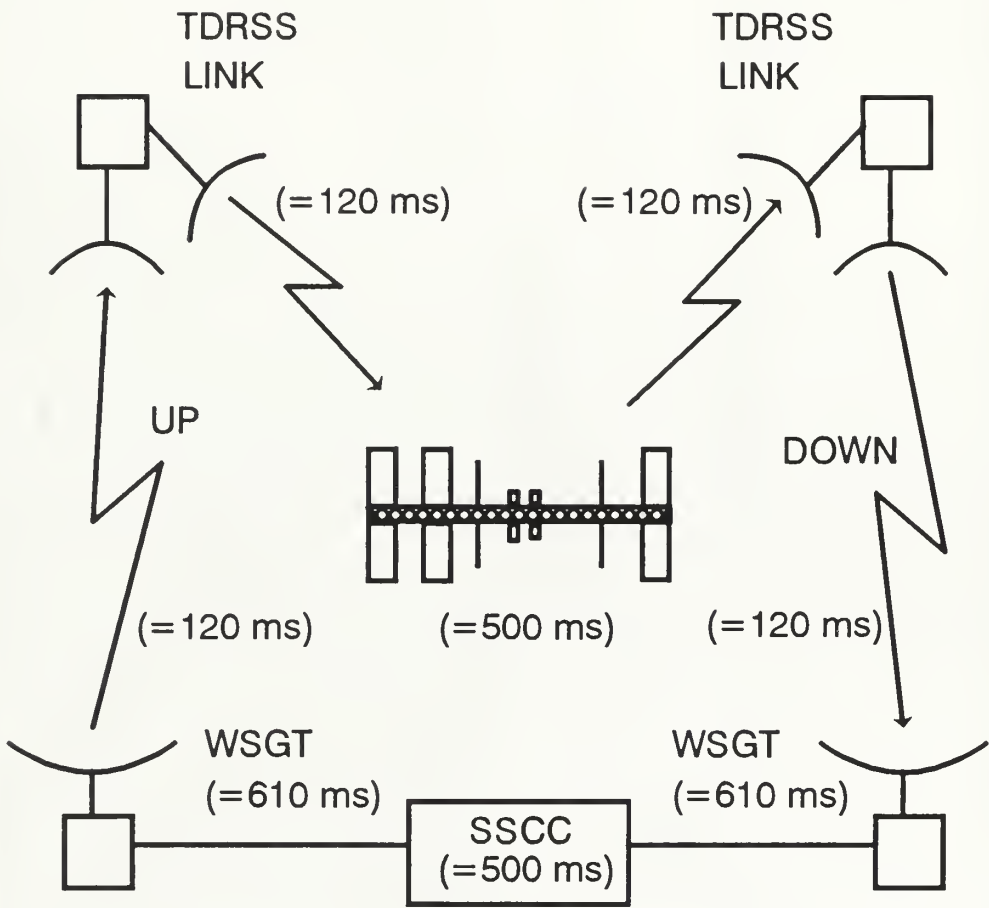

Figure 5.4 Space-Ground Communication Link



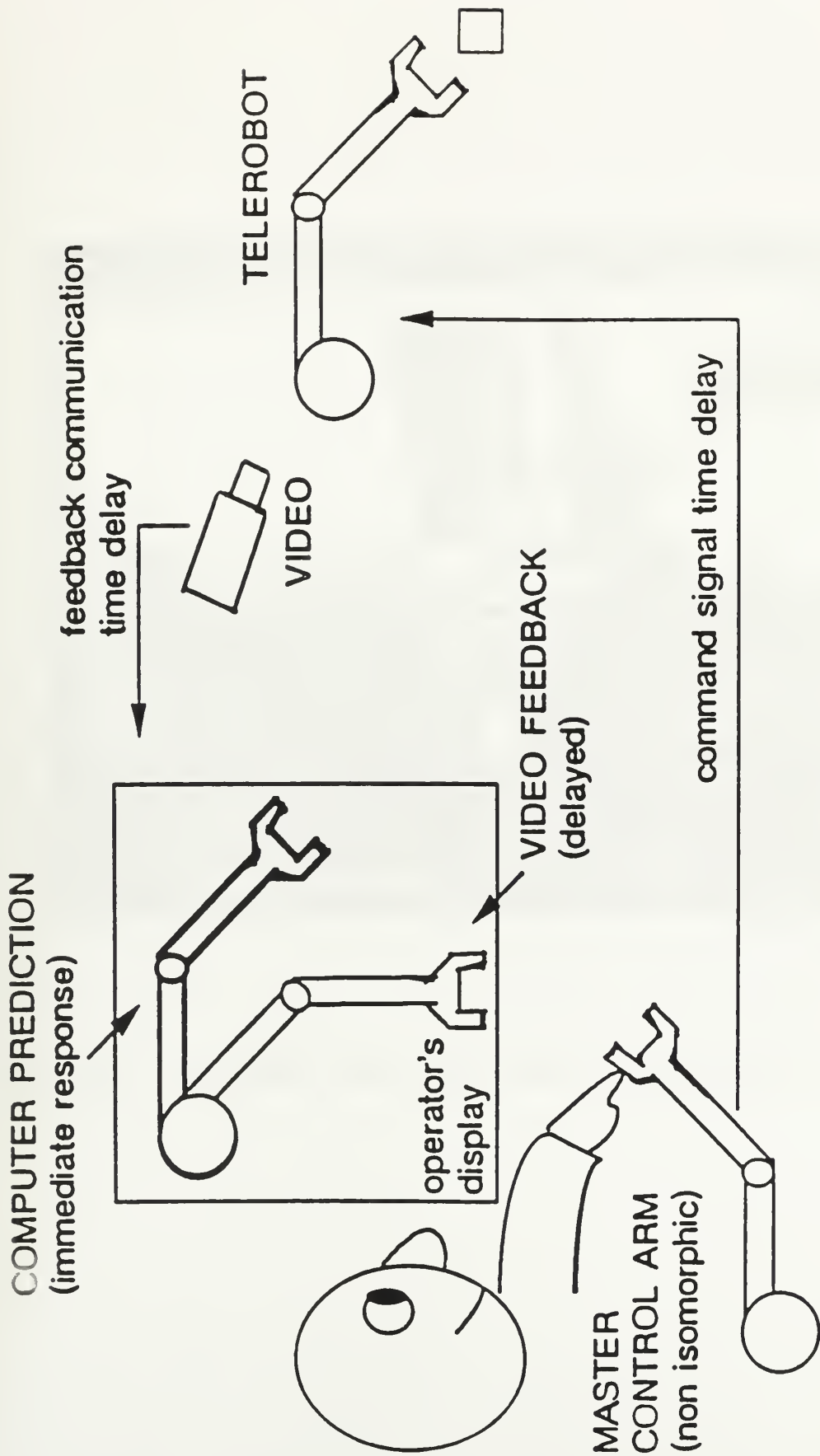

Figure 5.5 Diagram of teleoperator system using a predictor display [76]





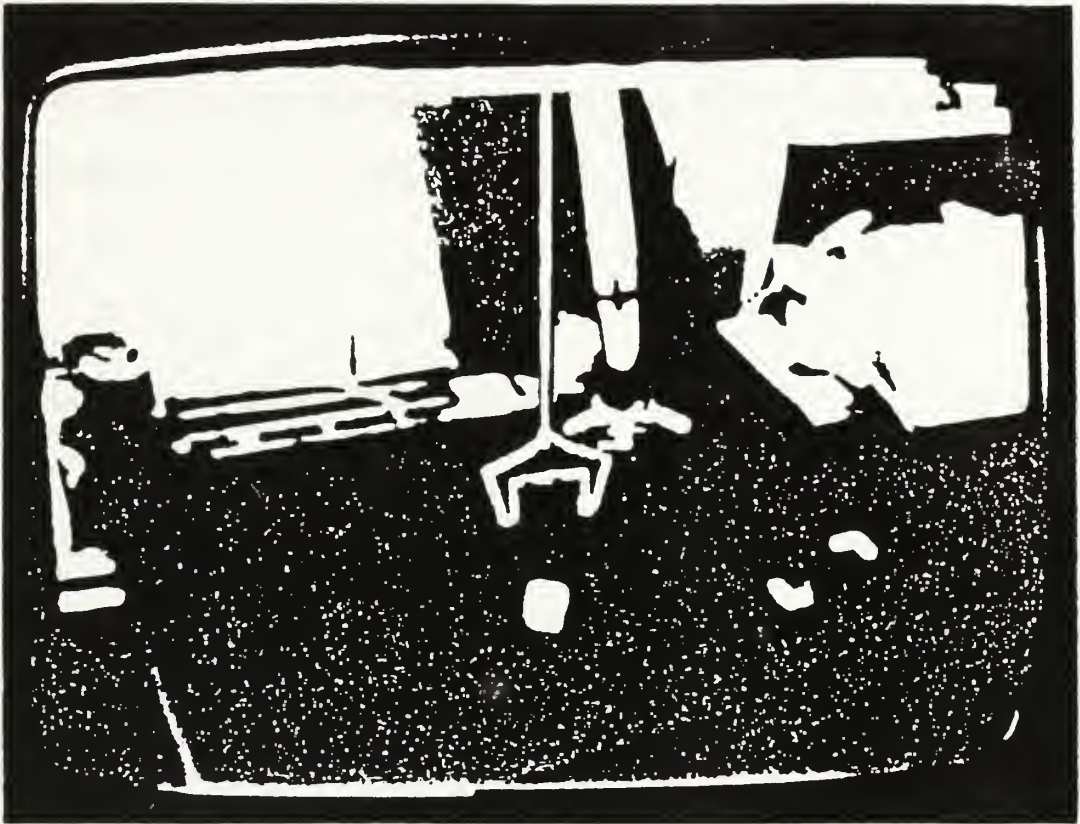

Figure 5.6 Photograph of stick figure superimposed on a video screen [76]



Supervisory control, as discussed in Section 5.1, can be an aid to control in the presence of time delay by delegating control to a local computer at the worksite. Overall commands and goals can be given from the ground, while the actual manipulations and process control are performed by the local computer. Sensors allow the automated system to make corrections using local closed-loop feedback, which is not subject to time delays.

### **5.3 The Use of Robotic Manipulators in Space**

Robotics will be needed to perform servicing tasks in remote locations such as in space. Robotic servicing is also ideal for circumstances that would otherwise endanger astronauts. As the space station and other space platforms are developed, robots will be indispensable for such servicing tasks as inspection, repair, consumable resupply, routine maintenance, and even assembly operations.

First-generation robots can be classified as manually slaved robots, which perform tasks in the general proximity of the operator. The Space Shuttle Remote Manipulator System is one example. Second-generation robots have now been developed that are controlled by teleoperation with limited autonomy. Second-generation robots can be placed into three general categories: fixed base, truss mobile, and free flying. Fixed base robots perform



relatively simple and routine tasks, allowing astronauts to perform the more complex ones. Truss mobile robots are attached to structures of large spacecraft and perform more complex servicing tasks, and also support EVA. Free flying robots are capable of orbital transfers and maneuvering, making them the most likely candidates for servicing multiple satellites. Third-generation robots will incorporate artificial intelligence and will be completely autonomous. Such futuristic robots may be used for construction, exploration, and manufacturing, as well as a host of unimaginable missions. [38]

The Flight Telerobotic Servicer (FTS) project, initially formed in 1986, was to become NASA's first operational robotic system. It was designed to perform servicing, maintenance, assembly, and inspection operations from the space station, the space shuttle, or an orbital maneuvering vehicle (OMV). Its launch was planned on one of the early space station assembly flights. Two test flights were planned on the space shuttle. The first flight was to test the performance and control of the manipulators in zero gravity, and the human-machine interface through a workstation environment. During the second test, the FTS was to perform representative servicing tasks. These tasks were to be performed on the aft flight deck of the space shuttle and use the RMS to bring the FTS to the work site. [5] Unfortunately, the FTS's budget was cut a few months before construction began.

The most visible equipment on the FTS includes two manipulators, a leg for stabilizing and positioning, cameras and lights, and a set of tools and end



effectors. At the end of each manipulator is an end effector changeout mechanism that allows for selection of appropriate tools and end effectors. Tools are stored in holsters when not in use. Figure 5.7 shows the design proposed for the NASA FTS.

There are three modes of operation for the FTS: fixed-base dependent operation, fixed-base independent operation, and transporter-attached operation. In dependent operation, the FTS is attached to the workstation and is plugged into a nearby port to get power and transfer data. For independent operation the FTS is still attached to the work site but uses internal battery power and transfers data via wireless link. In transporter-attached operation the FTS is attached to some transporter device, such as the RMS or OMV, and power and data are transferred via hardware connection to the transporter. [5] More details on the FTS, also known as the "tinman", can be found from AIAA papers N89-19870, N90-25537, N90-29821, and N90-29822. [5, 6, 7, 59]

As the technology evolves, more robotics research is being conducted, especially in the field of telerobotics and supervisory control. The first telerobots, such as the FTS, will be performing tasks similar to those now done by astronauts in EVA. The telerobot must be flexible enough to accommodate unexpected events. They will not be completely autonomous but will be supervised by a human operator locally in space, or remotely on Earth. For remote workstations, there may be a significant time delay of the transmission signal that must be accounted for when designing human-interactive feedback





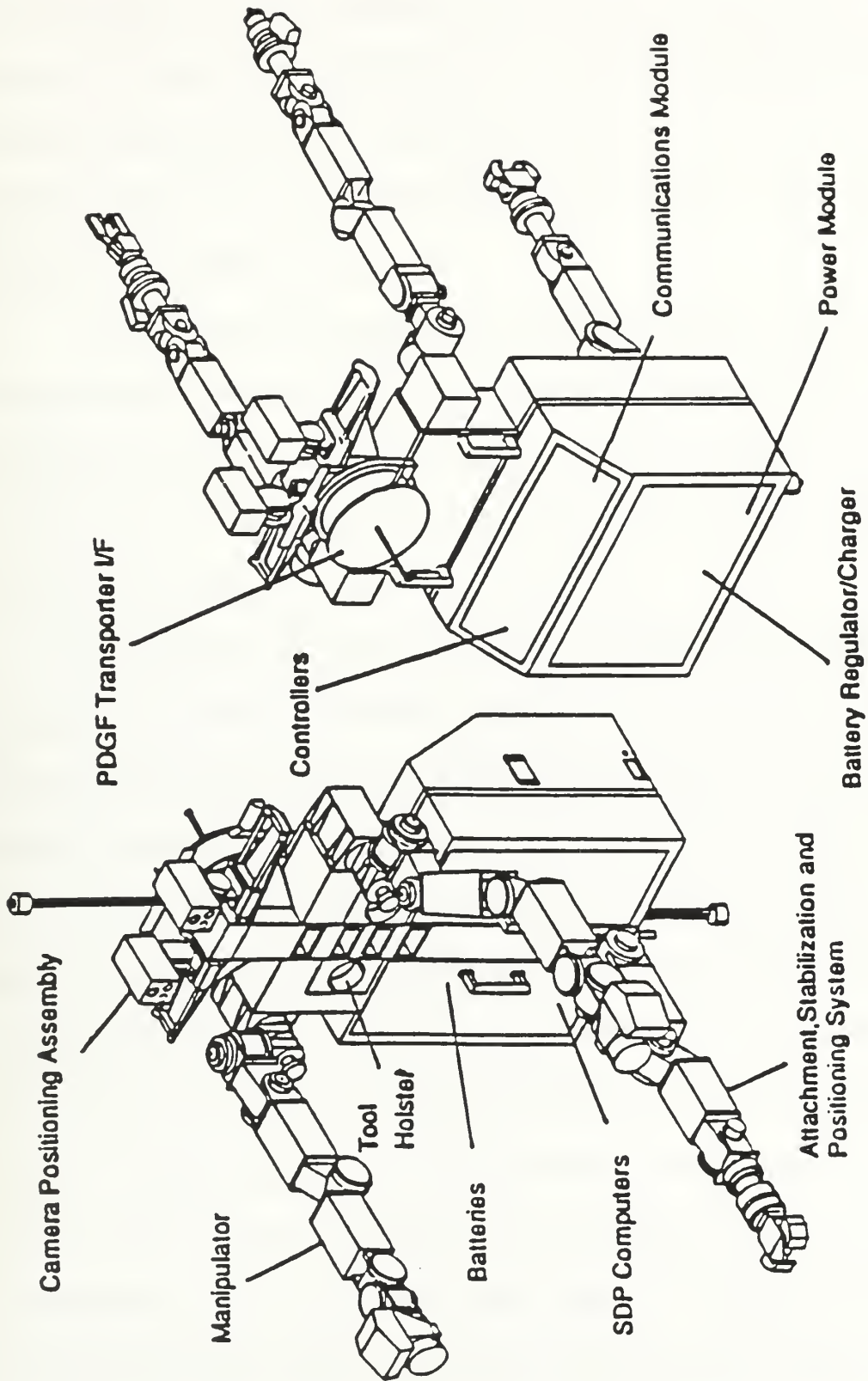

Figure 5.7 Design proposed for NASA flight telerobotic servicer (FTS) [59]



control systems. Predictor displays are one solution to that problem. Several telerobotic testbeds have been created for research and demonstration of remote servicing capabilities. AIAA papers N90-22312, N90-25538, and N90-29049 describe a few recent testbeds and demonstrations for the purpose of remote servicing. [42, 58, 63]

An extra-vehicular robotics device is being designed for use on board Space Station Freedom and is called the Special Purpose Dexterous Manipulator (SPDM). The SPDM is part of the Mobile Servicing Center (MSC) which is the Canadian contribution to the space station program. The MSC is for assembly and external maintenance operations.

The SPDM's configuration consists of a base section, an articulated body, two seven-degree-of-freedom manipulators, and a head with stereo cameras and lighting systems. This configuration is shown in Figure 5.8. The SPDM is designed to be compatible with the MSC as shown in Figure 5.9.

The base section consists of a latching end effector, a roll joint, supporting yaw and pitch joints for the articulated body, a CCTV camera, and a Power Data Grapple Fixture (PDGF). The PDGF provides a standard interface for power, data, and video information, which can mate with other PDGFs placed at strategic locations on the space station. The body sections of the SPDM contain electronic processors, provide temporary storage for Orbital Replacement Units and allow for storage of tools. The body sections unfold from a small storage volume reach difficult work areas. [75] Another way to



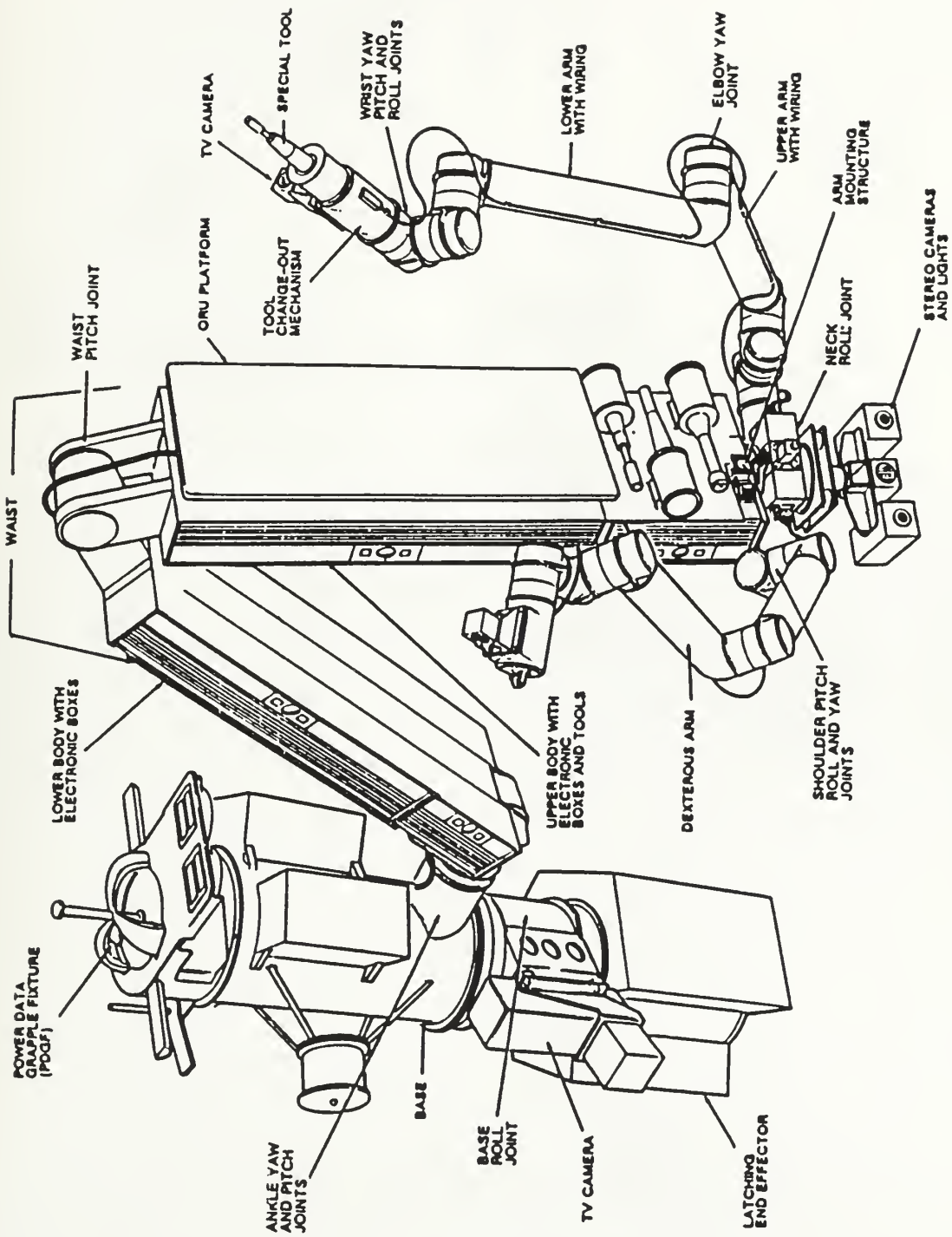

Figure 5.8 Special purpose dexterous manipulator (SPDM) configuration [75]



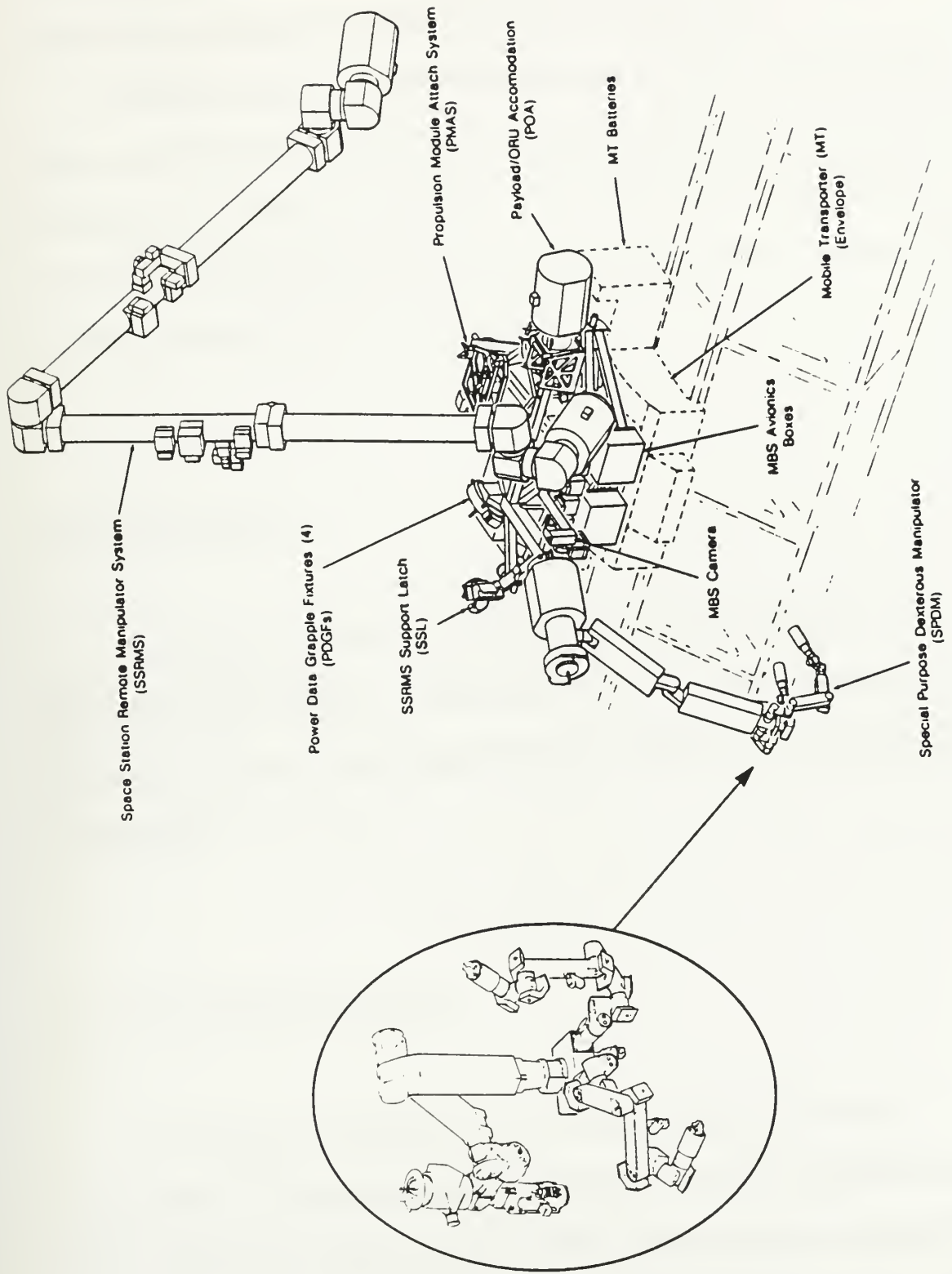

Figure 5.9 Mobile servicing center and SPDM [13]





extend the workspace of the SPDM is to place it on the end of the Space Station Remote Manipulator System, as shown in Figure 5.10.

Telerobotic space welding may first become a reality by using a robotic platform similar to the FTS or SPDM. If the appropriate sensors are mounted, an EBW gun is available in the form of an end effector tool, enough power is provided, and the proper software and control system is created, space welding should be adaptable to similar telerobots.

## **5.4 Welding Sensors**

This section describes some of the sensors typically used with automated welding systems. Some sensors are used for the welding process itself, while others are used to perform NDTs. Vision sensors can be used for both purposes.

### **5.4.1 Video Monitoring Sensors**

Since vision is a vital instrument for expert welders, it is similarly indispensable for remote monitoring and operational control. Visual sensing can be used during all major fabrication steps. During the pre-weld preparation,



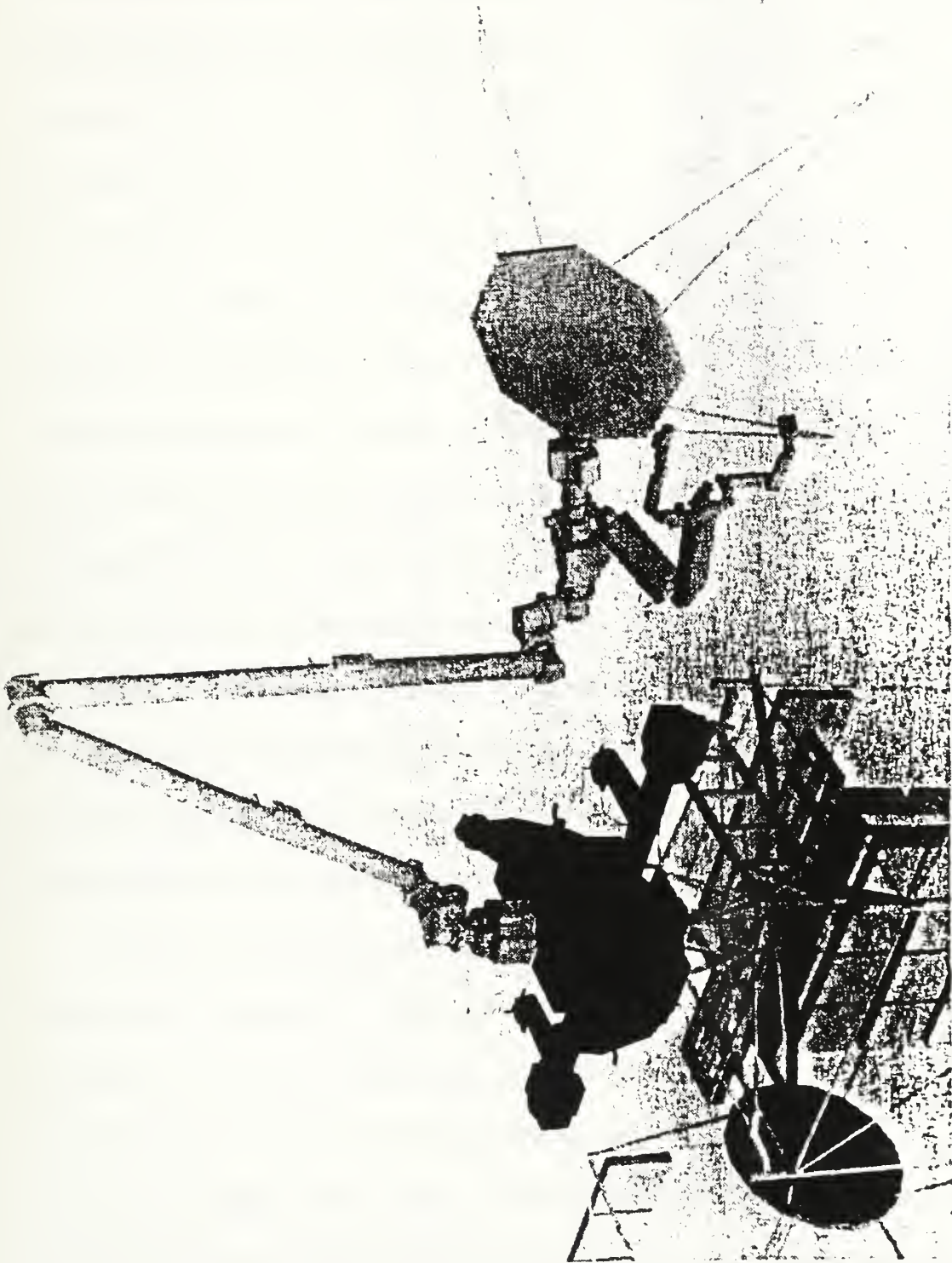

Figure 5.10 SPDM at end of the SSRMS [75]



the location and orientation of the parts can be sensed, and the joint type and shape can be identified. If fit-up is required, visual guidance is crucial to ensure proper positioning and to prevent interferences. The quality of the edge preparation and the surfaces of the material to be welded can be inspected and evaluated. If the gap size of the joint varies, the vision system can recognize this and adjust the welding parameters as necessary to compensate. [1, 2, 3]

For the welding process execution and control, the position and orientation of the welding torch can be sensed and controlled to track a welding seam for both single and multi-pass welds. The weld pool or bead geometry can be sensed in real-time to assist in automatic control. Thermal imaging can sense the heat input to the weld. [21] To sense plate distortions during and after welding, laser interferometry can be used.

After the welding is completed, the surface can be inspected for surface defects and proper weld bead geometry. For inspection of internal defects, other NDT methods must be used. Digital image processing and computer vision can be used to automate these other NDT methods. [25]

Some functional requirements that should be considered when using vision aids for welding include lighting, light filtration, placement of cameras, and number of cameras. Neither the operator nor a computer can operate successfully unless there is sufficient lighting. Lights can be placed to illuminate the camera's field of view. Since lighting conditions vary, the ability to adjust the lighting is important for both the operator and the computer based



system. The computer will need to recognize insufficient lighting by scanning the brightness of the video screen or by using some other form of light sensor. Light filtration is needed for welding operations so that the brightest portions of the image, such as an arc or a weld pool, do not cause the rest of the image to appear too dark. One method of light filtration known as "regionalized filtration" creates optimum filtration for any area within the field of view. [61]

Cameras should be placed to provide the maximum amount of information to the welding system and the operator. The automated welding system may only need a close-up view of the weld pool to perform the weld, but a wider view of the joint may be needed if it performs complex joint tracking. The human supervisor requires a much wider view of the entire telerobot. In fact, the operator would probably prefer to switch between several views and to zoom and pan onto specific details. Therefore, several cameras would most likely be needed for a human-tended welding system. Multiple monitors would also be useful to the operator.

#### **5.4.2 Joint Tracking**

In order for the telerobot to weld or inspect in a precise manner, a method of tracking the joint is needed. Joint tracking falls into two basic categories, contact and noncontact. Three major sensor classifications are





used in industry to perform this tracking: through-the-arc, preview, and direct-arc.

Preview sensing generates information about the joint before it is welded. This sensing can be performed with contact sensors, such as mechanical probes, or noncontact sensors, such as solid-state camera and optical laser combinations. Contact sensing is not adaptable to a variety of joint geometries. The probes can lose contact, they are subject to wear, they can limit the welding speed, and they cannot always follow complex contours.

Noncontact sensing does not have such limitations. It can provide information on the relative position of the joint with respect to the sensor and a geometric profile of the joint. Once the joint profile is known, welding parameters can be adjusted to ensure a constant weld fill.

#### **5.4.2.1 Vision Based Joint Tracking Systems**

Vision software is currently capable of recognizing a wide variety of joint and weld types, some of which are shown in Figure 5.11. The operator provides information about the joint type (fillet, groove, etc.), defines the desired tracking position (root, top left, etc.), and specifies the distance the robot is to weld along the joint. Once the system recognizes the joint, software routines can measure critical joint features used to position the welding tool. When



### Basic joint types



B-Butt

C-Corner

E-Edge

L-Lap

T-joint

There are only five basic types of joints. They can, however, be used in combinations.

### Types of welds (trackable)

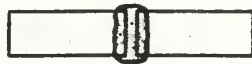

1. Square groove weld



2. Single-V-groove weld



3. Double-V-groove weld



4. Single-bevel groove weld



5. Double-bevel groove weld



6. Single-U groove weld



7. Double-U groove weld



8. Single-J groove weld



9. Double-J groove weld

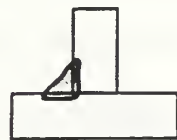

10. Single-fillet weld



11. Double-fillet weld

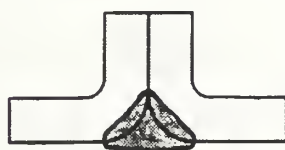
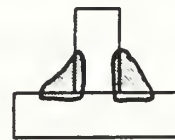

12. Flare-V-groove weld

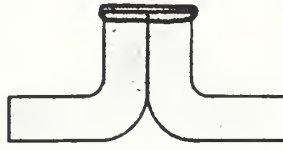

13. Edge flange weld



14. Plug weld

Other variations of welds are possible.

Figure 5.11 Some joint and weld types trackable by vision systems [17]



variations in joint features are sensed, such as in the root gap, welding parameters can be adjusted in real-time to ensure the correct amount of heat input, weld metal, and bead characteristics are obtained. This capability is known as adaptive welding control, since the system can adapt the welding process as the joint features are measured. Figure 5.12 shows a typical block diagram for adaptive welding control.

To determine a weld's three-dimensional geometry, structured laser lighting in combination with a solid-state camera can be used as shown in Figure 5.13. Planes of laser light are projected on the joint to produce illuminated stripes, which are viewed by the camera. If the position of the plane relative to the optical camera axis is known, then the three-dimensional coordinates of each point on the stripe can be determined. [1, 2, 3] When this system is run along the joint for some distance, a three-dimensional contour can be generated, as shown in Figure 5.14. The cross-section of this contour at a point in front of or behind the weld bead can be monitored by the human supervisor. The operator can view the oncoming joint track to ensure the weld bead will be laid down properly. Similarly, the completed weld bead can be inspected for surface flaws and defects.



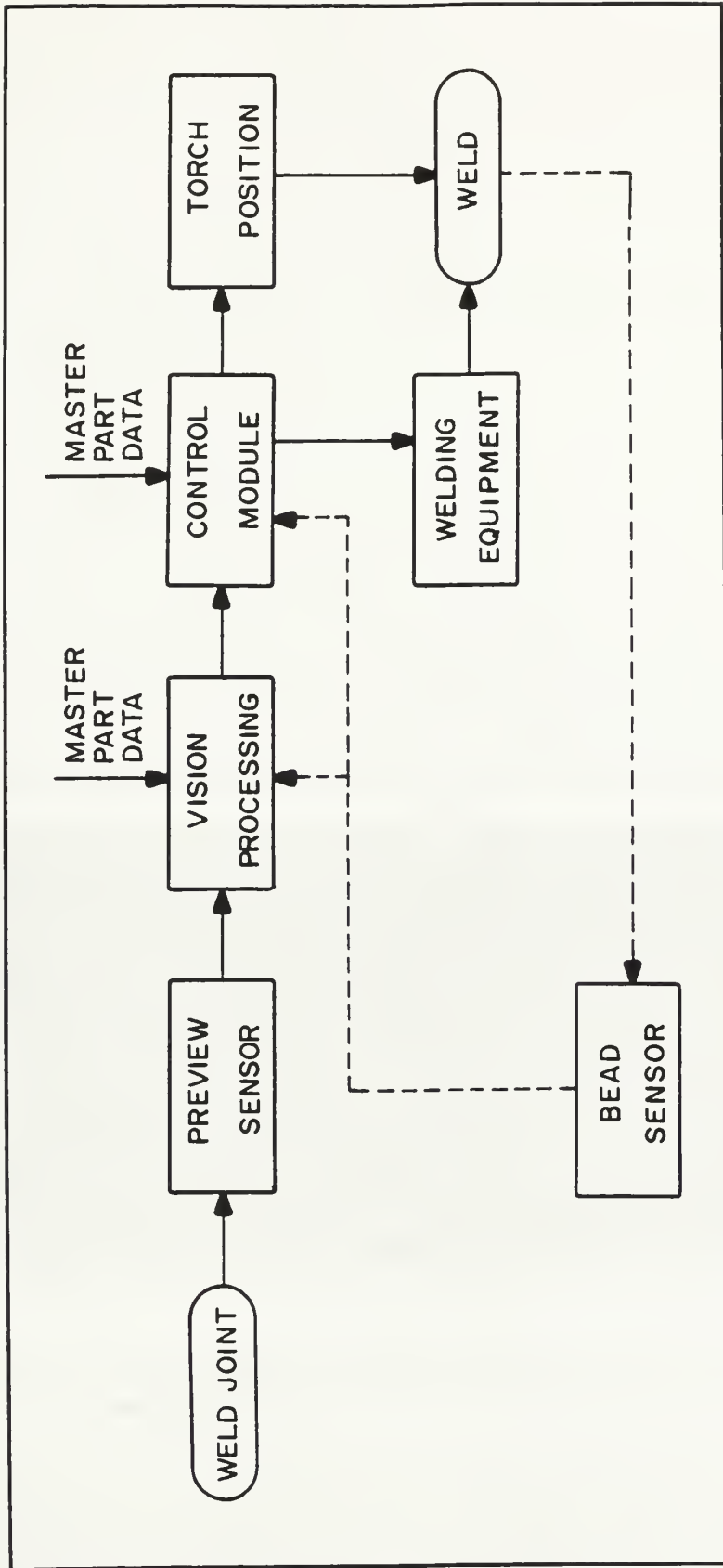

Figure 5.12 Adaptive robotic welding system architecture [2]





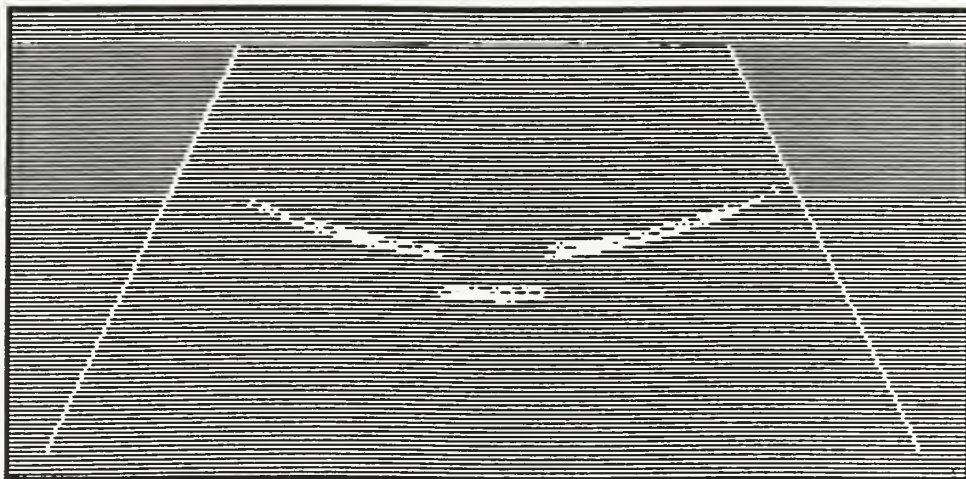
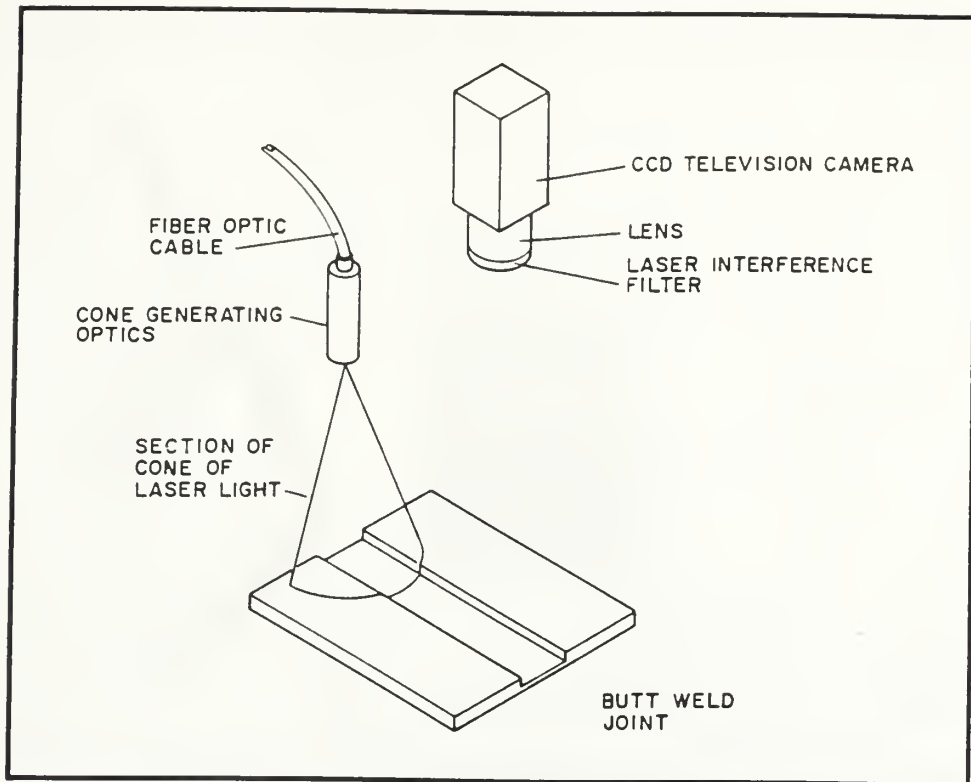

Figure 5.13 The principle of structured lighting for weld bead and joint inspection [1]



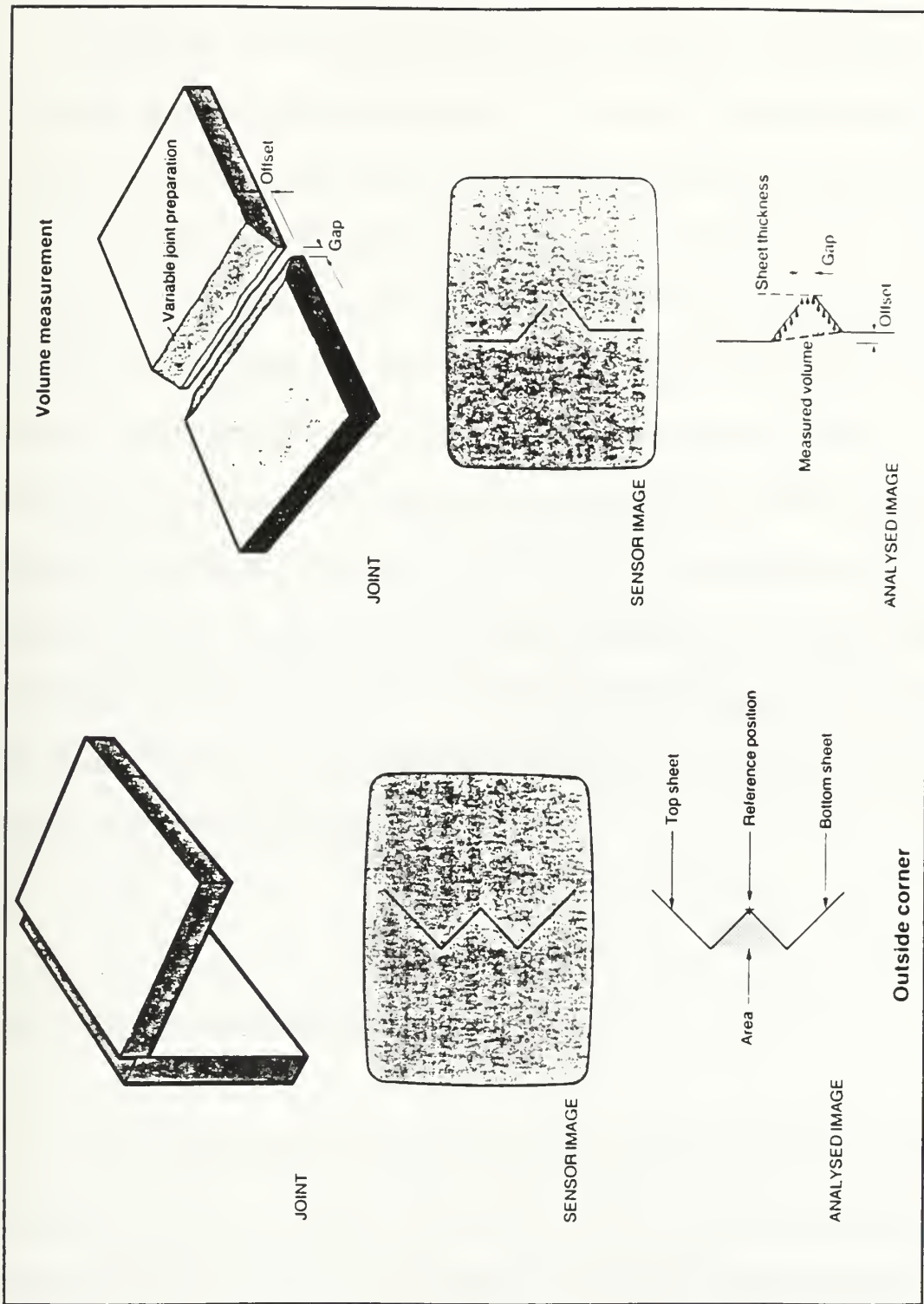

Figure 5.14 Pair of typical weld joints, the corresponding sensor images, and the analysis results [17]



### **5.4.3 Thermographic Sensing**

A fiber-optic thermographic sensor can be used for weld quality monitoring and adaptive process control. The infrared emissions from a welded surface can be monitored to determine the temperature distribution of the weld pool. The weld pool shape, absolute temperature, and the symmetry of the temperature distribution are related to some of the welding process variables, such as joint mismatch, root opening and plate thickness fluctuations, and thermal conductivity properties of the materials. Knowing the effect of temperature on the welding variables, the positioning of a welding tool can be adaptively controlled in real time. [21] This sensor would give the operator the ability to monitor the weld pool itself rather than sections of the joint in front of or behind the weld pool. Figure 5.15 shows a schematic view of a fiber-optic thermographic sensor. Such a compact unit could be mounted on or carried easily by a dexterous space manipulator.

### **5.4.4 Radiographic Sensing**

Due to the development of high quality image intensifiers and digital image processing, the ability to view interior weld defects using x-ray exposure has been greatly improved. As opposed to conventional film radiography, real-



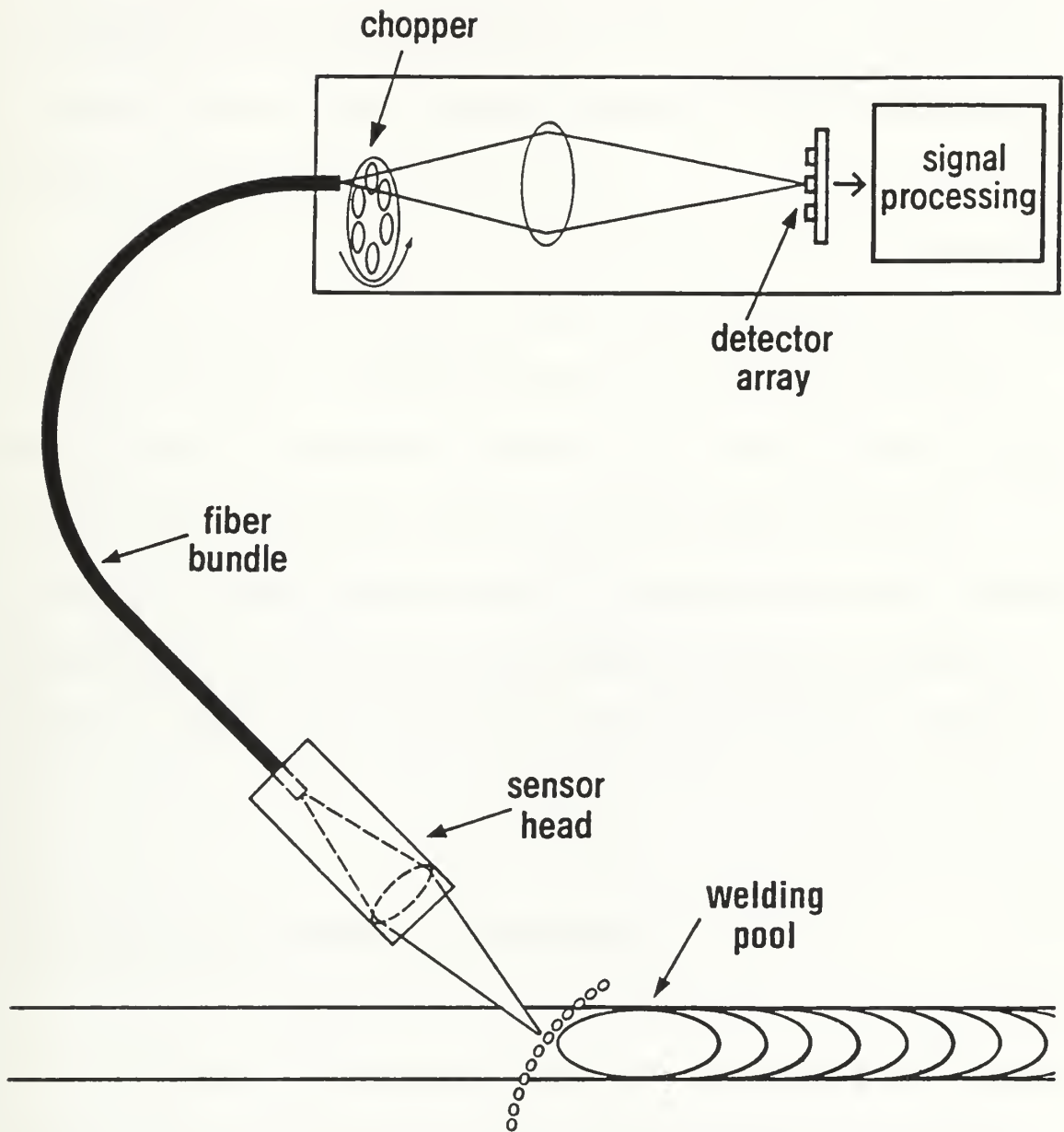

Figure 5.15 Schematic view of a linear array fiber-optic thermographic sensor [21]





time radiography allows the operator to inspect the weld on a video monitor as it is being laid down. The operator does not have to scan the same area twice. Not only can the operator view the weld, but the image can be digitized and analyzed by different pattern recognition algorithms for identification of weld quality and type of weld discontinuities. [70]

In addition, the information gathered during welding can be used in a feedback loop to assist in process control. Since the welding torch can be seen in the same image as the welding pool and the root opening, their relative distances can be determined and the welding tool tracked, as shown in Figure 5.16. Radiography can also monitor the depth and width of the weld penetration to ensure that the welding tool is traveling at the optimum speed for full penetration. There are, however, limitations to using such a system in space, such as excessive weight and the presence of radioactive material.

### **5.5.1 Expert and Knowledge-based Systems**

In order for an inexperienced welder to operate a telerobotic welding system correctly, a welding engineer's expertise needs to be encoded into computer software. A knowledge-based operating system can be used during each phase of the welding fabrication process from weld preparation to inspection. The expert system can be integrated into the same software that



## Features:

- (1) Monitor of Defect Formation:  
Cracks, Cavities, and Porosity
- (2) Monitor of Lack of Fusion and  
Weld Penetration

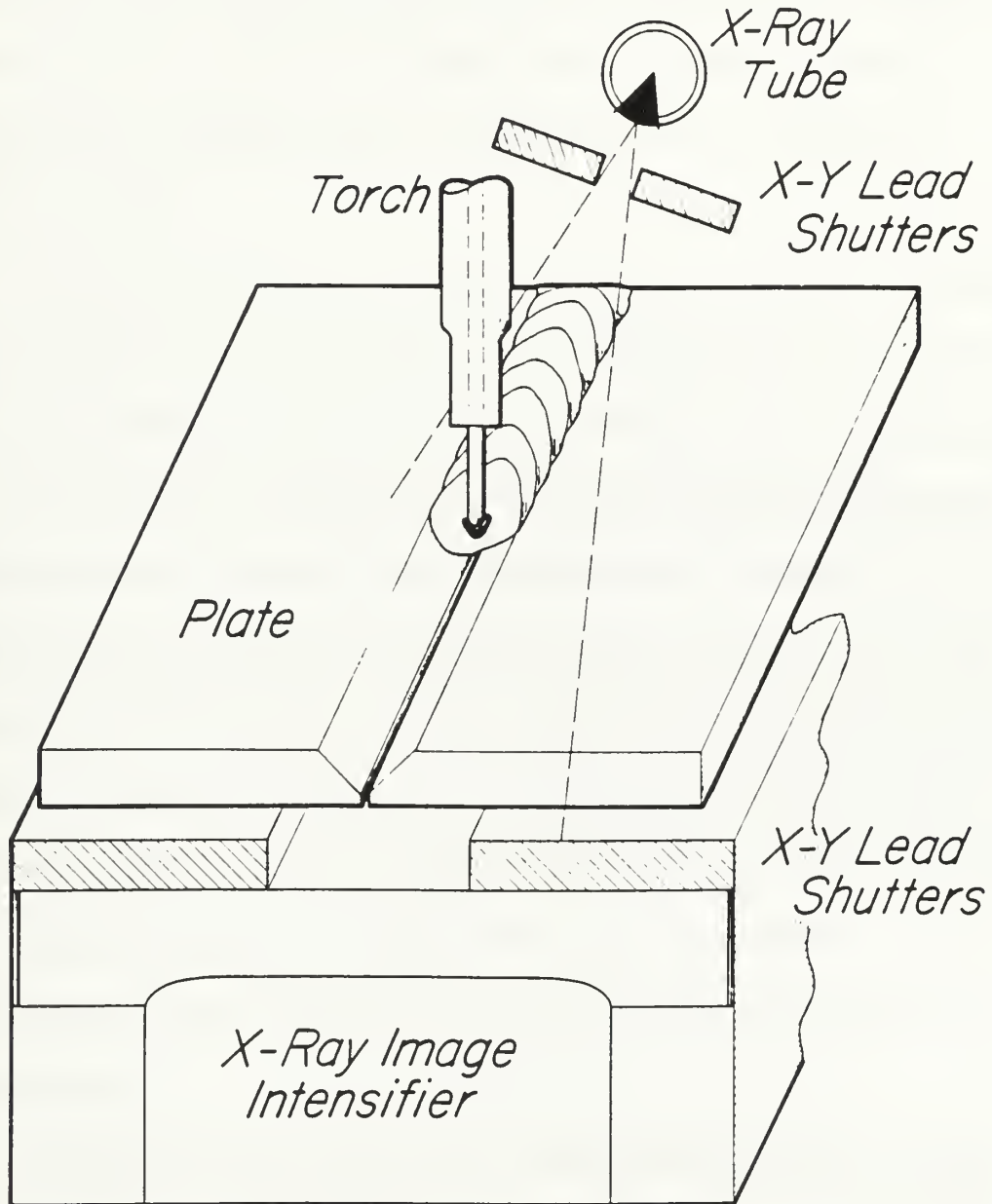

Figure 5.16 Schematic of vertical setup for the observation of real-time radiography [70]



operates the telerobot. If the operator is trying to solve a fabrication problem, he or she can seek advice from the expert system. During welding itself, the expert system can provide real-time intelligence for process control based on information from the welding sensors and the operator. The operator can decide when he or she wants to control decision making on and when the computer will work by itself. An expert system can analyze post-weld inspection data to identify defects and help determine their cause and significance. [68]

The expert system can be used to determine the schedule of fabrication steps events before welding begins. The system might ask the operator for data such as the type of material, joint type, thickness, desired welding position, etc. The output may include recommended data for preparation geometry, number of passes, and initial welding parameters such as voltage, arc current, working distance, travel speed, electrode diameter, and gas flow rate. The operator can have the system use those parameters or change them as desired. If the operator wants to know how the system arrived at those parameters, he can receive an explanation from the expert system. [43] Figure 5.17 displays the output of an expert system program, including the inputs, recommended welding schedule, and the resulting weld characteristics for a typical butt joint.

During the welding process, the knowledge-based system can make decisions with information from a combination of sensors and data from the



**Problem**

Butt-joint  
1/8 inch  
Flat position

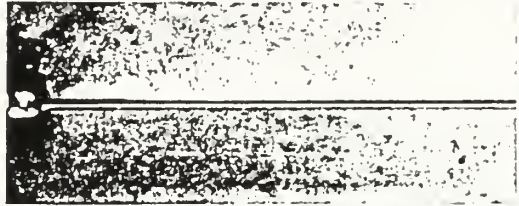

**Expert System**

**Welding  
Schedule**

**Preparation:**

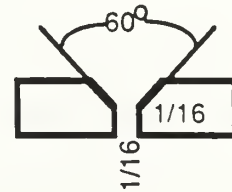

**Welding data:**

No. of passes: 1	U=18-22 V, I=165 A
tip-to-work distance: 1/2 -1 "	Travelspeed: 17 inch/min
Wire dia.: 0.045	CO <sub>2</sub> , 25 cuft/hr

**Result**

**Welded Part**

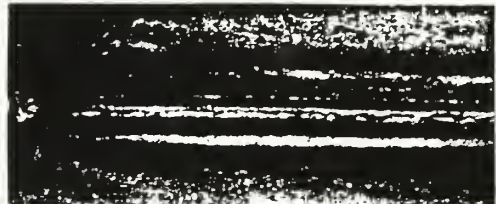

Figure 5.17 Expert system consultation session results [43]





operator. The combination of several sensors gives both the operator and the system a wider picture of the environment. This fusion of sensor data enables the system to reliably interpret the workpiece and equipment states, to anticipate future states, and to detect, diagnose, and correct faults. Rule-based decisions can be made automatically, or fault data can be sent to the operator with the system displaying recommendations for correction while waiting for the operator's response. [53]

When using a vision-based sensor or real-time radiography, an expert system is indispensable for identifying defects in weld bead size or penetration, undercuts, overlap, melt-through, cracks, etc. The expert system could help determine the significance of defects based on their size and extent, propose their causes, attempt to identify their actual cause, and propose corrections or repair solutions. [68]

## **5.6 Human Operator Interface**

After the operator has given the system control, it should require little operator intervention. The operator should just be concerned with monitoring the fabrication steps, evaluating the system's decision-making activities, and replenishing consumables as needed. The information should be represented in familiar terms that can be easily interpreted by the operator. The need for



memorization should be minimized, while the operator still has a rich set of commands for monitoring weld and system conditions. When information is needed, the interface should allow the operator to find it instinctively, with it presented in a flexible manner. [68]

One approach may have a symbolic graphic display that can be directly manipulated with a pointing device, such as a touch screen or a track ball. Graphics show the operator the status of a current operation. Commands could be supported by advanced menu techniques, including pull-down menus, pop-up dialogue boxes, and windows. Pop-up messages could beep to inform the operator of important changes in status, and the operator could display whatever windowed information is pertinent at the time. Figure 5.18 shows an example of what an operator interface display might look like.

Having more than one display may be useful, especially if multiple sensors, such as visual, thermographic, and radiographic, are being used simultaneously. One display might be dedicated to overall command and control placing information inside windows, another could focus on the joint space of the telerobot, and others could show sensor readings.

The operator should always be allowed to have as much control of the process as he or she desires. Of course there are many tedious manipulations that can be programmed into the system for autonomous operation. These programs can be stored in memory for future use thereby improving efficiency. This is analogous to storing macros in a word processing program.



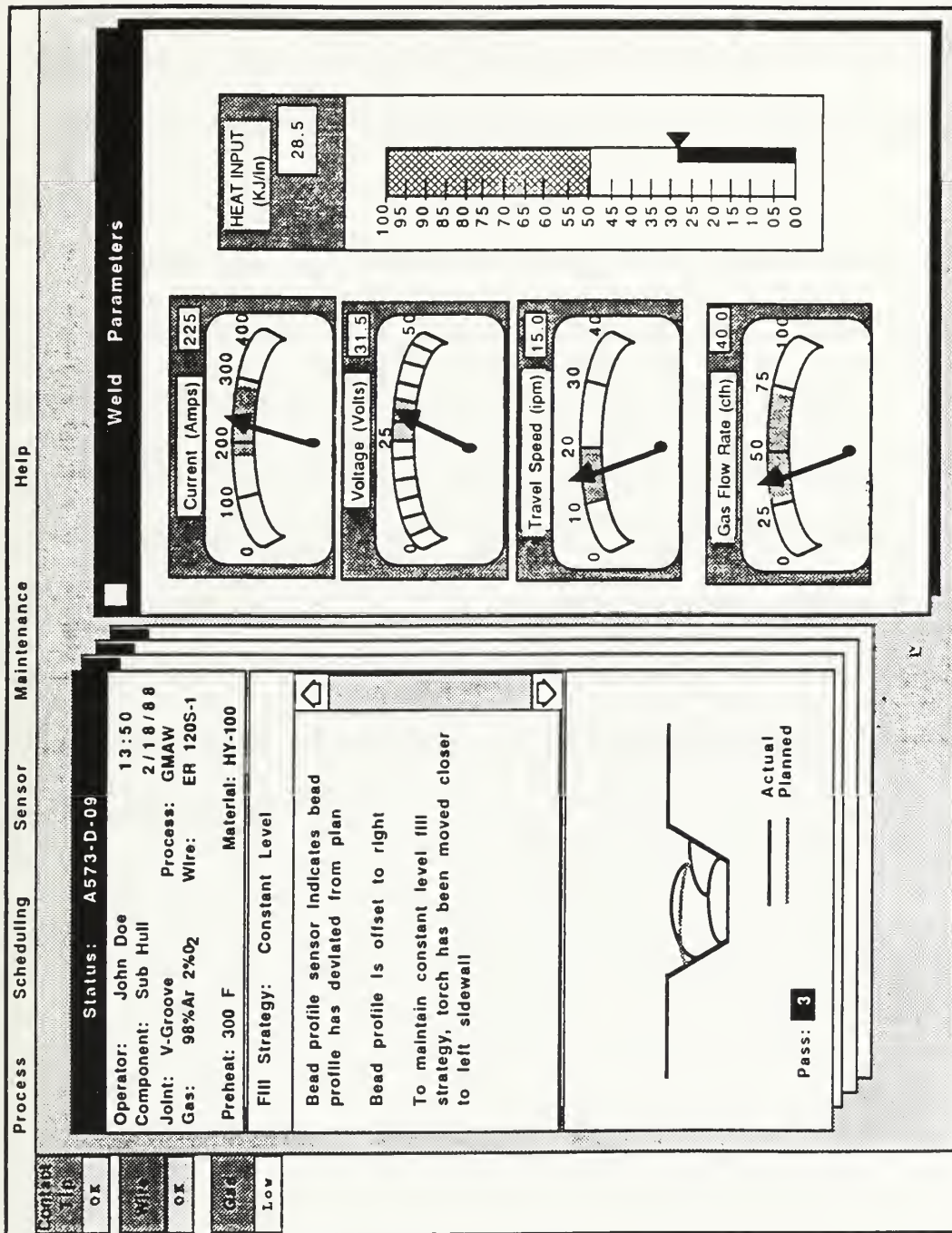

Figure 5.18 Operator interface display including menu bar, annunciators, status window, and weld parameters window [68]



For example, during a welding sequence, the operator can specify a distance for the welding tool to traverse along the joint axis before it stops. While the tool is moving, the operator should not have to perform any manipulations to assist in joint tracking. The operator should have the freedom to teach new trajectories and store additional macros for often repeated sequences.

In the design of human supervisory systems, care should be taken in task allocation between the operator and the automation. There are trade-offs to be made between monitoring functions and controlling functions. If the operator is given too many functions to perform, he or she may become overloaded and fatigued. On the other hand, if too many functions are automated, the operator can easily get bored, become complacent, and eventually lose the skills and competence needed to be a good supervisor. [76] This trend is displayed in Figure 5.19. Task allocation is one of the subjects included in the next section.





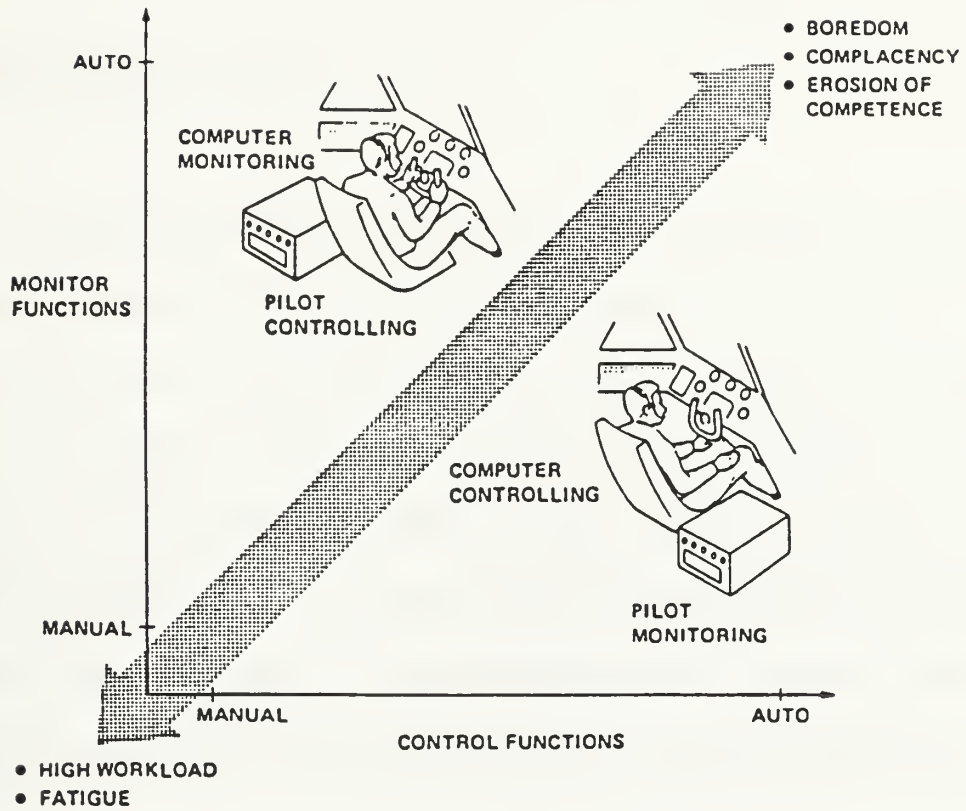

Figure 5.19 Task allocation: extreme effects of supervisory underwork and overwork [76]



## Chapter 6: Welding Fabrication Task Definition and Analysis

### 6.1 Work System Analysis

The welding fabrication problem is examined in a broad sense starting with the overall goals and a mission needs statement. The basic goal is to join two pieces of metal to make them act as one piece. This goal is complicated by the need to perform this task in the space environment and by using automation for the reasons discussed in previous chapters. The tasks can be defined in a general sense, but to specify them in greater detail, the needed equipment should be defined. This equipment should be selected to produce satisfactory results while minimizing the cost of the fabrication system as a whole.

#### 6.1.1 Work Objects

Materials. For welding in space, the work objects will likely be the structural materials for spacecraft, space stations, and extraterrestrial bases. The most common metals used for today's spacecraft are alloys of aluminum, beryllium,



magnesium, steel, and titanium. [4] The welding procedure can vary widely with various metals and their alloys.

Of these metals, steel is the easiest to weld. Relative to steel, aluminum and magnesium have higher thermal conductivities and thermal expansion coefficients, lower melting temperatures, and an absence of color change as their respective melting points are approached. Oxide surface films on these metals must be removed prior to welding to prevent defects. Due to their higher heat conductivities, welding procedures with higher travel speed and higher heat input should be used.

Titanium and beryllium are considered difficult to weld. These reactive metals have a high affinity for oxygen and other gases at high temperatures. The welding process cannot use fluxes or exposed heated metal to an atmosphere with reactive gases. Small amounts of impurities can cause these metals to become brittle. These metals also have oxide coatings that melt at temperatures considerably higher than the melting point of the base metal. Beryllium is a toxic metal requiring special ventilation and handling precautions. All of the materials mentioned above can be welded with either the GTAW or GMAW processes. [26]

Structural Geometry. The welding task may have various structural and joint geometries. Figures 4.15 and 4.16 in Section 4.7 show typical joint geometries for welded structures. The structure's geometric characteristics may have



straight or curved joints. Welding of pipes is an example of a curved weld joint. The structure should be designed for ease of welding so that construction can proceed rapidly and efficiently.

Structural obstructions can interfere with the workspace of an automated welding system. Either structural design must minimize obstructions, or the welding system must be clever enough to avoid them while adequately completing the weld. In order to handle a variety of structural and joint geometries, a flexible welding system is desirable. It is essential for certain repair jobs since countless unforeseeable geometries are possible. Flexible welding systems developed for space are more likely to use human supervisory control of automated welding than fully automated welding due to developmental and equipment cost constraints of the latter.

Surface Preparation. Except for steel, all the metals mentioned previously have oxide films that should be removed prior to welding. These metals will most likely be fabricated and machined in an atmosphere, which causes the oxide layers to form. Therefore, before the materials are welded in space, the oxide film needs to be removed to ensure a satisfactory weld.

The oxide film can be removed by mechanical, chemical, or electrical means. Mechanical methods include scraping, sanding, grinding, wire-brushing, etc. Chemical cleaning entails dipping areas to be welded into solutions and then rinsing them with water. This would be a good trick in microgravity





conditions. Electrical oxide removal involves cathodic bombardment to blast away the coating. Cathodic bombardment using reverse polarity occurs during the half cycle of AC GTAW, which has helped to make GTAW popular for welding aluminum. [26]

### **6.1.2 Equipment**

The equipment used for remote welding will of course vary with the process selected. For automated arc welding systems, the following equipment is typically used:

1. Power source and control.
2. Welding tool, torch, or gun.
3. Consumables: inert gas, electrodes, filler metal. (If needed)
4. Electrode wire feeder and control. (optional)
5. Master controller, for all system functions.
6. Arc and work motion devices.
7. Welding software for controller to conduct welding procedure.
8. Sensors (varies with desired capabilities).

Figure 6.1 shows a block diagram for automated arc welding systems.



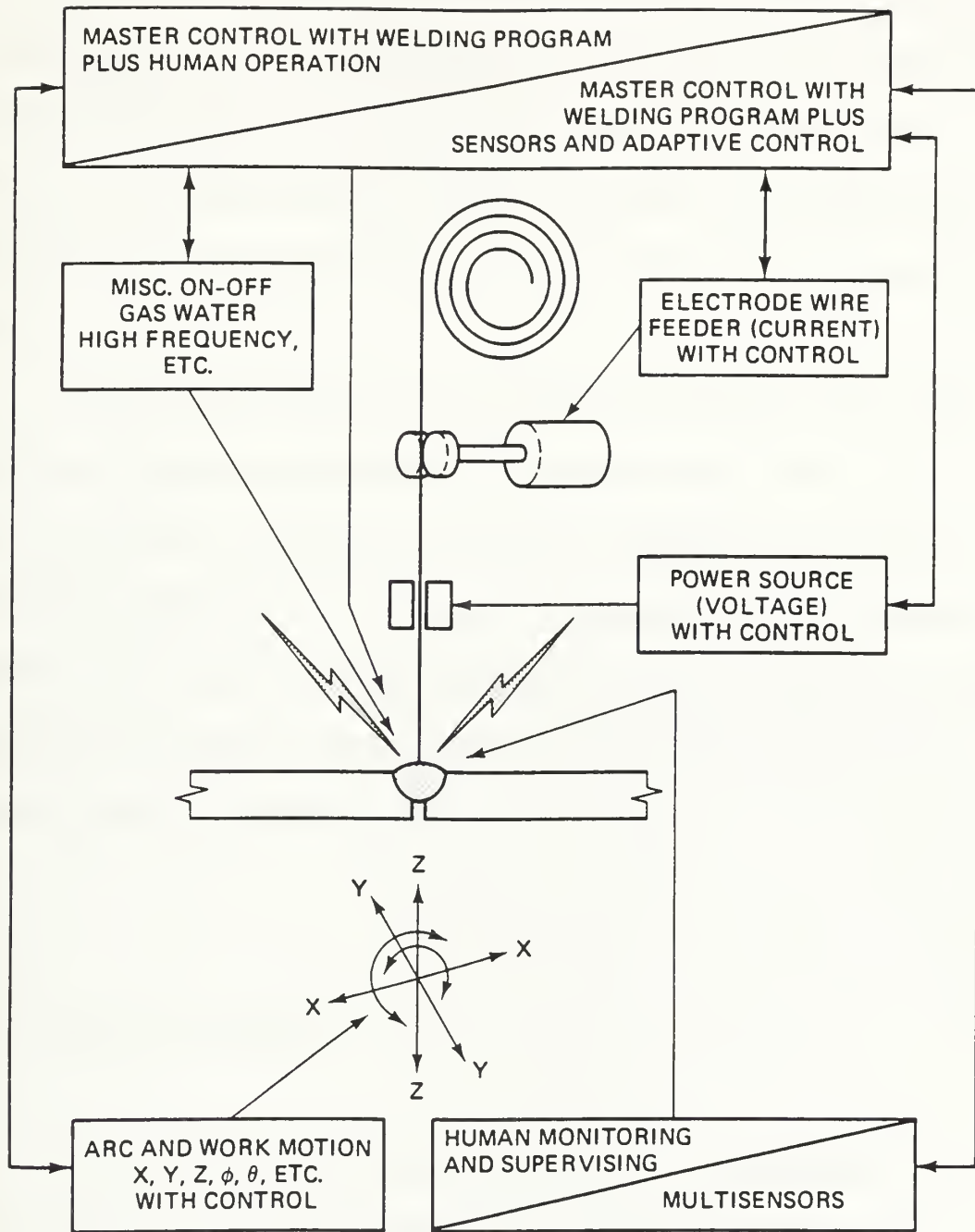

Figure 6.1 Automated arc welding system diagram [26]



For welding in space, some equipment could be integrated into space robotic systems. For example, the arc and work motion devices might be the dexterous manipulator arms, and a welding tool could be one of its end effectors. The master controller and welding program could be integrated into a space robotic system's programming and implemented when a welding task is desired.

Other equipment for remote welding is that necessary for the human operator to control and supervise the welding operations. Display and monitoring devices are needed, as well as the control interfaces such as keyboards, joysticks, etc. For viewing the welding arc and pool, proper light filtration will be needed. A master computer at the human operator's site may send command signals to a local computer system at the remote site and receive signals from local sensors.

### **6.1.3 Work Environment**

It is assumed that the human operator will be in a shirt-sleeve environment, while the welding itself will be conducted on-orbit outside a spacecraft or space station. The operator may be inside a spacecraft or on Earth. Ground-based operators will experience time delays in monitoring the process, and real-time force feedback will not be possible when manipulating in



a manual mode.

## **6.2 Task Analysis**

The phases of task analysis for a man-machine system is a top-down undertaking. Each phase will provide an increasingly detailed view of the human-machine interaction requirements. Task analysis can become quite detailed and therefore much of it is beyond the scope of this thesis. The principal objective of this section is task identification.

### **6.2.1 System Functional Analysis**

As described earlier in Chapter 4, the welding fabrication process can be divided into three steps: preparation, welding, and evaluation.

Preparation can involve cutting and forming the structural members, preparing edges for the weld, positioning and assembling the parts, and tack welding (if necessary). For pre-planned construction, structural members will likely be cut, formed, and have edges prepared on Earth prior to launch. Parts assembly and tack welding will be the main preparation steps on-orbit. Tack welding may not be necessary if a mechanical means of fastening can





adequately hold the parts in place during welding. For unplanned repairs, cutting of structural members may be necessary. It is recommended that a supply of structural material be available.

Next is the welding process itself. Depending on the structural design and material composition, the appropriate process and welding variables are selected to guarantee the size, shape, and quality of the welded joint. This is normally the function of welding engineers, but in remote welding, expert systems can help assist the astronauts when the advice of a welding engineer is unavailable or unattainable. The weld bead is then laid at the proper location while the system process control regulates the welding parameters in the presence of external disturbances. Multiple weld passes may be required for thicker structural members.

The final step involves the determination of weld quality by inspection or testing. The quality of the weld is characterized by weld bead location and geometry, weld and base metal microstructure and metallurgical properties, and the structural integrity of the joint and the welded structure as a whole. Section 4.6 describes currently accepted methods for evaluating weld quality. For the purpose of this task description, the assumed method of quality evaluation will be visual inspection using remote CCTV cameras. Factors affecting this choice include low cost and the capability for simultaneous evaluation by welding experts on Earth. Using fully automated weld sequences will also help to ensure reasonable weld quality.



For all three of the process steps, positioning and manipulation of tools is necessary. Tools need to be placed at arbitrary positions and orientations in space. During welding and inspections joint tracking is required at a constant speed, distance, and orientation.

### **6.2.2 Operational Sequence Analysis**

To proceed any further in this analysis, a more detailed description of the joint geometry and welding system is required. At this point the following assumptions shall be made:

1. Two pieces of arbitrary geometry are to be joined . The larger of the two will be designated as the main structure, while the smaller piece shall be designated as the workpiece.
2. The remote welding system and equipment are positioned relative to the main structure such that it is within the work space of at least one of the system's dexterous manipulators.
3. The workpiece is sized so that it can be easily handled by the system's manipulator and positioned at any desired orientation.



4. Adequate lighting is available to perform the tasks.
5. A GTAW system is used (like other methods, GTAW is still experimental for space use).

#### Planning Phase:

1. This phase involves deciding what are the goals, and formulating a strategy for going from the initial state of the system to achieve the goal state. For example, in most circumstances the operator needs to determine which two pieces are to be joined and in what geometrical configuration.
2. The operator needs to specify input values to the system such as material types, plate thicknesses, and when to initiate phases.

#### Preparation Phase:

1. The appropriate workpiece is positively identified and is grasped by the manipulator.



2. The workpiece is positioned adjacent to the main structure.

3. If so designed, the workpiece and the main structure can be secured by mechanical means. If not, then tack welding may be necessary to hold the pieces together. If a second manipulator is available then it might be able to hold the pieces together during tack welding or the main welding process.

If mechanically fixing the workpiece to the main structure, consider the following scenario: Pegs on the workpiece fit into holes in the structure to align the pieces. There may be a mechanical spring-loaded locking mechanism that engages when the pegs are properly mated to the holes. Then follow steps 3a and 3b:

3a. Orient the workpiece so that the pegs are above the holes and normal to the surface of the main structure.

3b. Move the workpiece towards the main structure while guiding the pegs into the holes until the two pieces are flush.

4. Verify by inspection that the workpiece and the main structure are properly aligned. For example, if the joint is a "T" joint then the workpiece should be oriented 90 degrees from the surface of the main structure. If the joint is tack





welded or held in place it is important that the workpiece is located at the desired location of the main structure. Markings on the main structure and the workpiece may provide a guide for alignment.

5. If the joint is to be tack welded, follow the welding procedure but only for a short distance. Welding process control is not as crucial for tack welds, although their correct locations should be specified. At least two tack welds are required to properly fix the workpiece to the main structure.

#### Welding Phase:

1. The manipulator either grasps the welding tool or if it is so designed, changes the end effector into a welding instrument.
2. Position and orient the welding tool to the welding start location. Orientation of the tool depends on the joint geometry. For a fillet weld, the angle of the tool will generally bisect the 90 degree joint with respect to the plane normal to the weld direction.
3. For video monitoring systems, engage light filters to prevent damage to the cameras and to enable the human operator to adequately observe the welding



process.

4. Clamp the work connector to the main structure to complete the circuit for the welding arc.
5. Initiate welding arc with the tool at the proper distance from the joint.
6. Begin moving the tool along the joint at the designated weld speed.
7. Maintain process control within design parameters while visually monitoring the process. The parameters to be monitored are usually arc voltage and current, welding speed, and weld bead location and geometry.
8. Upon reaching the weld termination point, extinguish the welding arc.
9. Disable viewing filters as necessary to better view the completed weld.

Inspection Phase:

1. Turn on extra lighting sources if needed.



2. Grasp inspection camera with manipulator or change end effector to a camera tool as applicable. In some systems a camera may be permanently mounted on the manipulator to view the operating area of the end effector.
3. Orient camera to view the desired portion of the weld.
4. Adjust camera settings such as focus, zoom, contrast, etc.
5. Move camera along the weld at the proper speed for adequate inspection of weld quality.
6. If properly equipped, some cameras can zoom in and focus on the microstructure of the weld and examine possible defects more closely.

### **6.3 Task Allocation**

The job demand on a human operator is highly dependent on the capabilities of the welding process equipment, sensors, and the operator interface. If the operator is an astronaut inside a spacecraft, then the system should be designed to have as little operator demands as possible. This is because astronauts invariably have many responsibilities. If construction and



repair becomes the astronaut's primary duty, then the system may be designed to be monitored constantly. There are also trade-offs among system complexity, weight, and cost. Before job demand can be analyzed, we must decide which tasks may be controlled by the human operator and how they are to be accomplished. The following lists correspond to those in Section 6.2.2.

### Planning Phase:

1. Overall goal selection and planning are inherently human tasks. Most likely, these functions will have already been decided by planners long before the mission occurs.
2. Since the human operator will have overall control of the process, he or she will supply the initial inputs to the system. However, some inputs may not be needed if they can be inferred from other inputs. For example, a bar code might be placed on the workpiece allowing the system scanners to identify its geometric and material properties as well as other data.





## Preparation Phase:

1. Although pattern recognition and target identification can be performed by machines in some cases, human skill at these task is far superior. Grasping the workpiece with a manipulator can be controlled manually, or it can be performed automatically.

2 and 3. These assembly tasks are typically performed by space telerobots, either controlled by the operator or performed automatically for pre-programmed sequences. There are many factors beyond the scope of this thesis involved with structural assembly operations using space robots. [see 8, 10, 22, 24, 33, 34, 35, 40, 49, 58, 75, 77]

4. Although inspections to verify alignment can be performed by either humans or machines, operator control is prudent since realignment will be difficult to correct after the piece has been welded.

5. Tasks associated with tack welding are very similar to the welding process itself. The operator needs to decide where the tack welds are to be placed and how many are needed.



### Welding Phase:

1. Grasping the welding tool or changing the manipulator's end effector to a welding instrument is best performed automatically. This is because the welding tool will likely have a well-defined location and orientation with respect to the manipulator, making this an easily automated task. It is possible for the operator to do these manipulation tasks but they might prove to be needlessly tedious and inefficient.

2. Since the welding start point is likely to be located at a random coordinate within the manipulator's workspace, sensors will be needed to recognize the geometry of the joint if the location is to be found automatically. The sensors might focus on the entire structural geometry, find the joint, then start welding. But unless construction plans are well defined and pre-programmed, a human operator needs to specify the joint to be welded, the start point of the weld, and the weld direction.

One solution to help the machine solve these problems is to use a graphic label sequencing technique. Machine vision recognizes a graphic label, which contains information to find the weld start and stop locations. For example, numbers and arrows might be painted where the weld is to start and end, giving the machine a path to follow.

For a human operator, manipulating the welding tool to the weld start



point would not be difficult with adequate video camera coverage of the joint, manipulator, and welding tool. One problem the operator might have is precise placement of the torch at the start location. Machines tend to be more precise in manipulation tasks. If the precision of the start location is not critical then the operator should perform this task. If precision is necessary, then the operator could position the tool near the start location, and have the machine make any necessary corrections (possibly by using reference markings).

Tool orientation can be handled similarly to the tool positioning problem. The joint geometry must be recognized and the tool properly oriented relative to the particular joint. For a simple bead on a plate, the tool needs to be oriented normal to the plate. For corner welds, the tool's angle should generally bisect the angle of the corner.

3. The human operator can easily flip a switch to engage lighting filters over the video cameras. But if the operator forgets to do this, then the cameras might be permanently damaged by bright light from the arc. Fiber optic CCTVs are susceptible to this problem. One way to avoid this mishap is to provide an interlock that automatically engages the filters prior to starting the arc. The key to filter selection is to adequately protect the viewing equipment while giving the operator the clearest possible view of the weld pool.

4. The clamp mechanism should be easily actuated by the manipulator. The



clamp needs to be placed on the structure so that it will not interfere with the welding process. The use of human intuition would be the better choice here. Also, precise positioning of the clamp is not necessary so the operator can handle this task.

5. The arc start should be initiated by the operator because safety becomes a concern at this point. The operator can check the area prior to starting the arc to ensure that the arc will not damage equipment or endanger nearby personnel. The distance from the joint at which the arc is started can be more precisely controlled by the machine.

6. Moving the arc along the joint at the appropriate speed and distance from the joint is best maintained by machines due to their ability to produce consistent and precise results. This task can be controlled by the operator but machine controlled welds tend to be of higher quality. (see Section 4.6.2)

7. Unless the operator is a welding expert, process parameters displayed as raw data will be difficult to interpret and use. For example, if the parameters given are 25 volts DC, 1 ampere, at 0.5 centimeters per second, and so on, the unskilled operator will not be able to determine if the weld will be adequate. An expert system could determine the acceptable range for each parameter, and inform the operator when the actual values go out of range. Then the expert





system could suggest corrective actions to the operator.

If the system uses adaptive welding techniques, sensor input is used to make corrections to the welding process in real time. This is preferable to real-time operator control decisions because humans react more slowly. By the time the operator makes the proper correction, a portion of the substandard weld will have already solidified. Therefore, the machine should conduct welding process control while the operator monitors the process.

8. The machine should automatically terminate the arc once the proper weld length has been traversed. Sensors may be employed to detect the welding stop point. If the weld length was specified by the operator, then the machine should know when to stop based on the welding speed. The operator should always be able to terminate welding whenever the quality is insufficient or for safety reasons.

9. As in task 3 above, the most convenient way to disengage the filters is a machine controlled interlock that engages the filters prior to welding and disengages them after the arc is extinguished. If the operator controls the filters, remembering to disengage them after welding is not as critical as engaging them beforehand since there is no risk of damaging the equipment if the filters are left on.



## Inspection Phase:

Since inspections allow both the operator and welding experts on the ground to verify the quality of the weld, it makes sense that most functions should be controlled by a human operator. The operator should have the freedom to position the camera and zoom in on possible defects.

Some automated features would make the inspections more convenient for the operator. If the system's camera is not fixed to the manipulator, then a macro for grasping the camera tool with the manipulator would be helpful. Most inexpensive camcorders have many automated features for camera settings such as autofocus and contrast, which could be incorporated into the system. Another useful feature for inspections is the ability to scan along a portion of the weld at a designated speed and a fixed distance from the weld.



Table 6.1 Task Allocation Summary

Phase	Task	Preferred Allocation	Rationale
Planning	1	Operator	Goal and priority setting
	2	Operator	Inputs for plan
Preparation	1	Op/Mach	Pattern recognition / precision motions
	2,3	Op/Mach	Task dependent
	4	Operator	Evaluation of results
	5	Operator	Planning ability
Welding	1	Machine	Boring, repetitious task
	2	Op/Mach	Planning ability / precision
	3	Machine	Safety, damage prevention
	4	Operator	Planning ability, less precision needed
	5	Op/Mach	Safety / precision
	6	Machine	Precision, consistency, higher quality
	7	Op/Mach	Monitoring / process control
	8	Op/Mach	Safety / deductive analysis
	9	Machine	Deductive analysis
Inspection	1-6	Op/Mach	Defect recognition / operator convenience



## **Chapter 7: Experiment: Remote Viewing of Weld Defects**

Focusing on the inspection phase of the welding process, an experiment was performed to test the ability of a remote operator to recognize weld defects using a video image from a CCTV camera located at the inspection site. Variables studied in this experiment include camera field of view, lighting conditions, and video viewing vs. direct viewing. The weld defects studied were, of course, surface defects.

### **7.1 Experimental Objectives**

This experiment will show how certain key variables affect weld defect recognition when viewing samples via remote video cameras. The distance between the camera and the weld was varied to change the field of view (FOV) of the video image. Welds were viewed from four distances. It will be determined quantitatively how weld defect recognition changes when camera distance is varied.

The lighting conditions were also varied at each of these four distances. The lighting conditions were constant in intensity but varied in relative angle to





the weld samples. Two lighting conditions were used: one with the light source directed longitudinally along the weld and another with the source directed transversely to the weld, as shown in Figure 7.1. The lighting condition can be important when identifying certain weld defects. Shadows cast by the weld contours and defects vary in length and shape depending on the lighting conditions. This experiment will determine how the lighting conditions affect weld defect recognition and under which lighting condition each type of defect can best be recognized.

Additionally, the subjects viewed the weld specimens directly. Direct viewing allowed the subjects to get a three-dimensional perspective of the specimens rather than the two-dimensional perspective of the video monitor. The subjects could handle the specimens and tilt them at any angle to view the defects at the best perspective. The direct viewing recognition results will be compared to that of remote video viewing results. It will be determined which viewing method provides a higher degree of recognition success, and by how much this degree of success will differ.



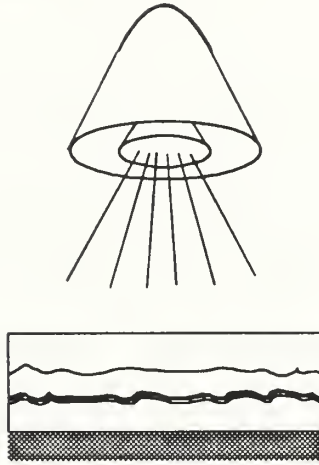

a. Above lighting

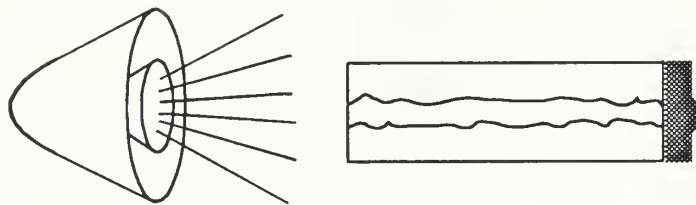

b. Side lighting

Figure 7.1 Lighting conditions for experiment



## **7.2 Equipment and Weld Defect Samples**

### **7.2.1 Experimental Equipment**

The equipment for filming the weld defects included a video camera system, monitor, videocassette recorder (VCR), and a color video printer. Other equipment used was a camera tripod, high intensity lamp, and a platform on which the samples were placed. Table 7.1 lists the equipment and some specifications. The equipment layout and connections are shown in Figure 7.2. Figure 7.3 is a photograph of the monitor, camera power supply, VCR, and video printer used for this experiment.

The video camera system can also be used as a microscope, depending on which lens is attached. The camera system consists of a power supply, fiber-optic cables, and the lens unit. The lens unit was mounted on a camera to securely fix the lens in the proper orientation and distance from the weld samples.

The weld samples were placed on a platform during the video filming. The same platform was used for all samples to ensure consistent lighting and contrast. The platform is beige in color, while the weld samples are gray.



Table 7.1 Equipment list and specifications

Equipment	Specifications
Video Monitor	Sony Trinitron color video monitor PVM-1343MD 13" diagonal screen Superfine pitch Trinitron picture tube
VCR	Sony DA Pro 4 Head VHS NTSC standard Video recording sytem: rotary two-headed helical scanning system Video heads: double azimuth four head
Camera System	Hirox HI-SCOPE compact micro vision system Model KH-2200 MD2 MX-MACRO Z (x1 - x40 power) lens
Video Printer	Sony color video printer mavigraph UP-3000 Sublimation heat transfer printing system Picture elements 716 x 468 PELS; 750 x 490 PELS Total gradation: 265 levels for each yellow, magenta, and cyan





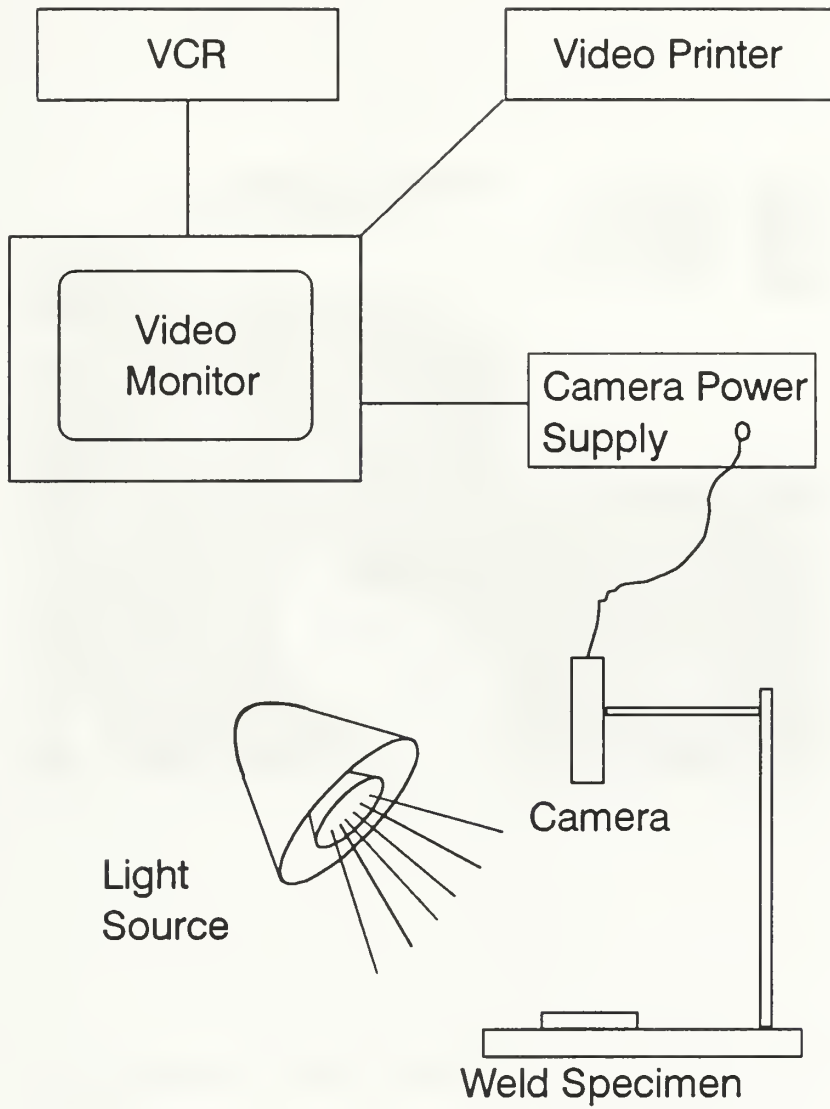

Figure 7.2 Equipment layout and connections



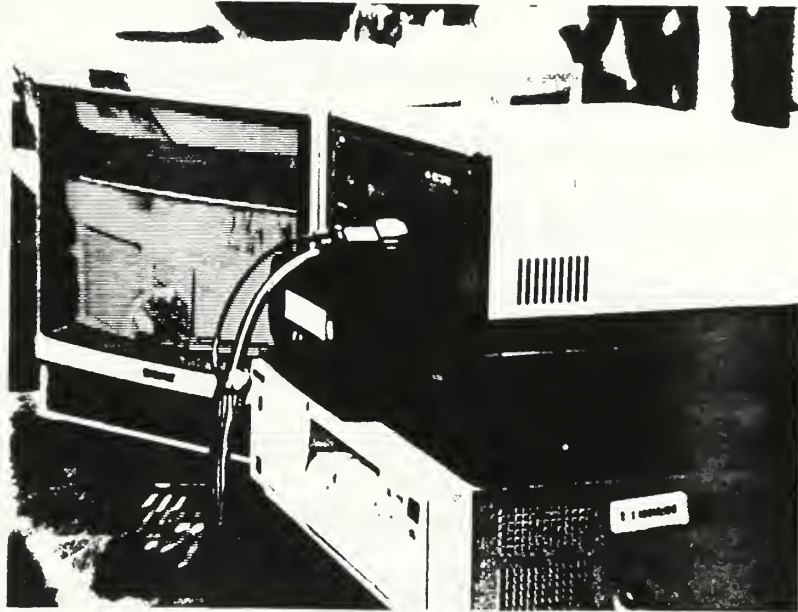

Figure 7.3 Photograph of monitor, camera power supply, VCR, and video printer



## 7.2.2 Weld Defect Samples

The weld samples used for this experiment are plastic molded replicas of typical weld imperfections. The replicas were created by the National Shipbuilding Research Program (NSRP), a cooperative effort involving both commercial and naval shipyards, related industries, and educational institutions. The replicas were created for a project entitled "Visual Reference Standards for Weld Surface Conditions." The purpose of the project was not to establish visual standards for the acceptance of weld quality, but to use the samples as a tool during discussions and agreements between producers and the customers.

Thirty-two weld replicas were created, all selected from a much larger number of samples. During the selection process, three levels of magnitude were determined for each imperfection type. A published standard was used whenever possible for comparison of the model's visual attributes.

Four general defect types were selected in creating the replicas: undercut, porosity, roughness, and contour defects. Two forms of porosity defects are present, scattered and clustered. Two forms of contour defects were used, re-entrant angle and irregular contour. These six forms of defect are defined as follows:

1) Undercut: The melting away of a welding groove sidewall at the edge of a layer or bead, thus forming a sharp recess in the sidewall.



2) Scattered porosity: Voids or pores scattered more or less uniformly throughout the weld metal.

3) Clustered porosity: Several pores appearing in clusters separated by considerable lengths of porosity-free weld metal.

4) Roughness: Surface irregularities along the longitudinal axis of the weld.

5) Irregular contour: Surface irregularities along the transverse axis of the weld.

6) Re-entrant angle: The angle between the plane of the base metal surface and a plane tangential to the weld bead surface at the toe of the weld. (If this angle is excessive and the weld bead doesn't blend smoothly into the base metal, it may be considered a defect.)

Of the thirty-two samples, half are butt welds and half are fillet welds. Five of the six defect types has three gradual levels of defect severity, making up fifteen of the sixteen samples. For the re-entrant angle defect type, there is only one example provided for each weld type. The three levels of defect severity, A, B, and C, correspond to the minimum quality level appropriate to critical, general, and secondary applications, respectively.





Appendix I includes a description of the defect severity levels for each defect type, a list of defects associated with each plastic replica, corresponding identification codes for this list, and a table describing the relationship between existing acceptance standards and the selected samples.

### **7.3 Experimental Procedure**

To support the objectives laid out in Section 7.1, an experiment was devised to test human subjects' abilities to recognize the weld defects described in section 7.2.2. First a videotape was produced containing several shots of each sample at varied camera distances and lighting conditions. Then subjects viewed the videotape and attempted to identify the various weld defects. The same subjects also viewed the plastic replicas directly, allowing them to hold and rotate the samples at any desired angle. The subjects were asked to again identify the various weld defects.



### 7.3.1 Videotape Production

In order to standardize the experiment's conditions and to minimize the time required for the subjects to view the specimens, a videotape was produced. For purposes of this experiment, a sequence is defined as that portion of the videotape showing a single weld sample. A grouping consists of all 32 weld samples videotaped under the same conditions.

One key consideration in taping the sequences was to ensure that the order of the sequences would minimally affect the subject's ability to recognize other sequences on later portions of the videotape. There are only 32 weld samples, and each of them is viewed nine times: at four camera distances each in two different lighting conditions, plus once directly, for a grand total of 256 sequences. Therefore, the sequences were arranged to minimize the possibility that subjects' knowledge from earlier groupings would affect their answers on later ones. Groupings under conditions believed to show the least amount of information were taped first.

The distance between the camera and the weld sample was varied at four increments: 40, 30, 20, and 10 inches. The 40 inch shots were taken first to minimize the amount of information at the beginning of the tape, followed by the 30, 20, and 10 inch shots. It should be noted that this order was based on the logical assumption that the farther the camera distance, the harder to distinguish details and defects. Experiment results should confirm or disprove



this. Figures 7.4 through 7.7 display the same sample at the four distances and show the relative size of the welds as seen by the subjects.

The lighting conditions were also varied relative to the longitudinal axis of the weld, as shown in Figure 7.1. At each distance all 32 samples were videotaped under two lighting conditions, one with the lighting source directed along the longitudinal axis of the weld, and the other with the source directed transversely to the weld axis. Figures 7.8 and 7.9 shows an excessive re-entrant angle defect with the lighting conditions varied. Similarly, Figures 7.10 and 7.11 show varied lighting conditions for an undercut defect.

Since it was unknown at the beginning of the experiment how lighting conditions would affect defect recognition, the order on the videotape of the two conditions was chosen arbitrarily. The same lighting intensity was maintained on the weld samples by keeping the light source a distance of 21 inches and at a 45 degree angle relative to the center of the weld sample.

The length of each sequence on the tape varied from 5 seconds for the 40-inch shots to 20 seconds for the 10 inch shots. The closer shots were longer because the specimens needed to be moved across the camera's field of view in order to show the entire length of the specimen.

Table 7.2 shows the order of the sequences on the videotape. The scale of the weld sample as it appeared on the diagonal 13-inch monitor relative to actual size is also listed for the various camera distances. The order of individual sequences within each grouping was randomized on the tape.





Figure 7.4 Photograph of fillet weld sample at camera distance of 40"

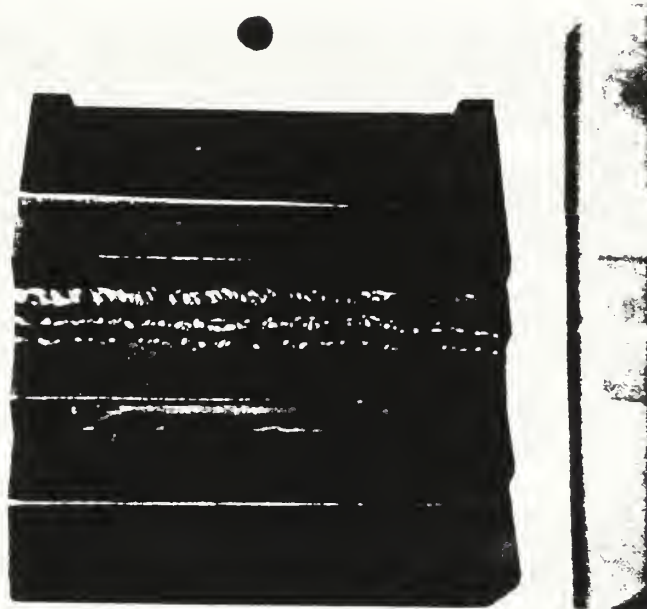

Figure 7.5 Photograph of fillet weld sample at camera distance of 30"





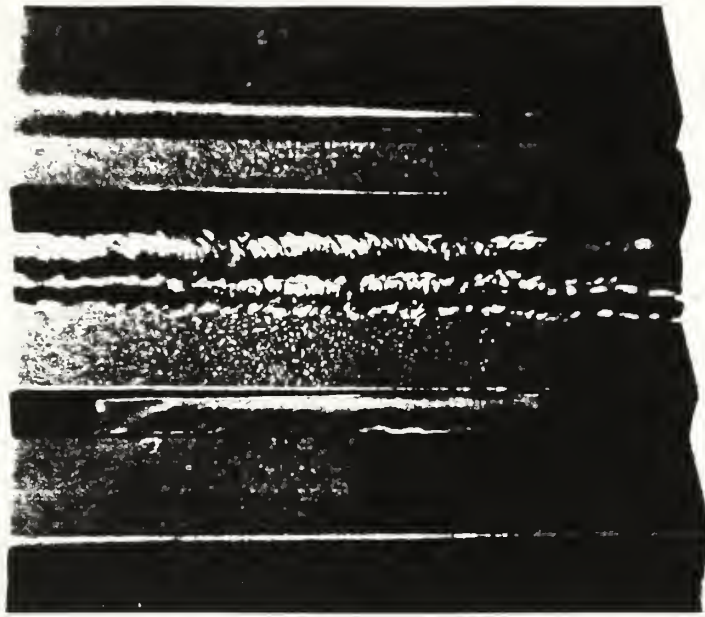

Figure 7.6 Photograph of fillet weld sample at camera distance of 20"



Figure 7.7 Photograph of fillet weld sample at camera distance of 10"



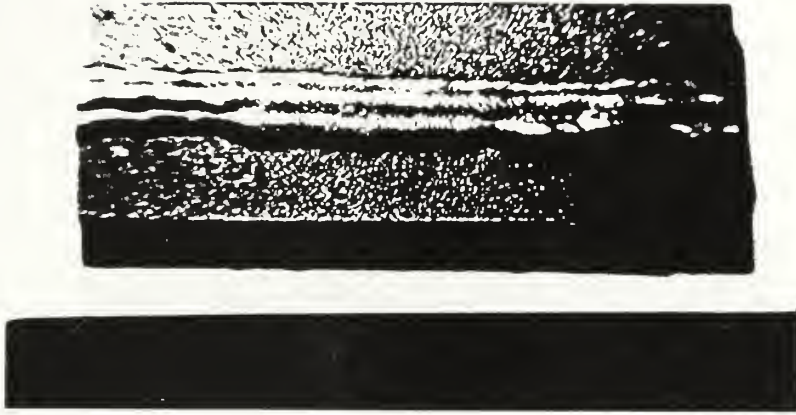

Figure 7.8 Photograph of excessive re-entrant angle defect with lighting from above

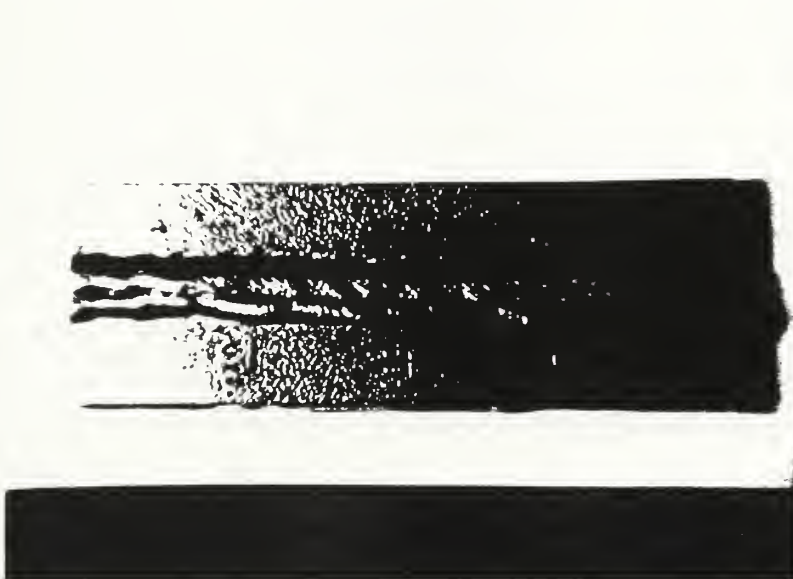

Figure 7.9 Photograph of excessive re-entrant angle defect with lighting from the side





Figure 7.10 Photograph of undercut defect with lighting from above



Figure 7.11 Photograph of undercut defect with lighting from the side



Table 7.2 Order of conditional viewing arranged on video tape

Order	Distance	Scale	Lighting Condition	Weld Type
1	40"	1 : 0.75	Side	Fillet
2	40"	1 : 0.75	Side	Butt
3	40"	1 : 0.75	Above	Fillet
4	40"	1 : 0.75	Above	Butt
5	30"	1 : 1	Side	Fillet
6	30"	1 : 1	Side	Butt
7	30"	1 : 1	Above	Fillet
8	30"	1 : 1	Above	Butt
9	20"	1 : 1.5	Side	Fillet
10	20"	1 : 1.5	Side	Butt
11	20"	1 : 1.5	Above	Fillet
12	20"	1 : 1.5	Above	Butt
13	10"	1 : 3.25	Above	Butt
14	10"	1 : 3.25	Above	Fillet
15	10"	1 : 3.25	Side	Butt
16	10"	1 : 3.25	Side	Fillet





Random order reduces the chance that subjects might memorize each of the thirty-two samples before the experiment is over.

### **7.3.2 Videotape Viewing**

Six subjects were selected to take part in this experiment. The subjects were not experienced weld inspectors, so they were briefly instructed on what the defects were and what they look like. Each subject was given written instructions, a defect-type code sheet, and several data recording sheets. The instructions and the first page of the data sheets are shown on the following pages as Exhibit 7.1. The defect codes were listed on the first data recording sheet, so once the subject turned the page they could look at the defect-type code sheet as an aid. Since the seven data sheets are almost identical, only the first sheet is included.

The subjects were asked to identify the weld defects shown to them on the videotape. For each weld specimen, the subject was asked to circle one of the six defect codes. If the subject saw no defect, they were instructed to circle NO. Note that every weld specimen had defects, but the subjects did not know this. Giving them the "no" defects option helped to minimize guessing.

Since some of the weld samples appeared to have multiple types of defect, the subjects were asked to identify a secondary defect type if they



## Exhibit 7.1 Subject instructions and data sheets

### Visual Weld Inspection Experiment Instructions:

This experiment is intended to test the ability of a welding inspector to evaluate weld defects when using a video system for remote inspection. You will first view many sequences of welds on video tape and make your best guess at what the defect is or if any defect is present at all. The sequences are filmed at various distances and using two different lighting conditions. Then after the movie, you will get to handle the specimens and make a final evaluation.

Please follow these directions when completing the experiment:

1. Fill out the top portion of the first data sheet. Use a red or bright-colored pen, if possible.
2. Make sure the tape is fully rewound before you begin viewing.
3. Play the tapes in the proper order: Tape 1: 40", 30", and 20" shots; Tape 2: 10" shots. Total play time is about 45 min.
4. You will probably have to pause the tape on each specimen to give yourself time for viewing and filling in the data sheet. Please do not rewind the tape other than to look at the current specimen. It is intended that you look at each only in the proper order.
5. The numbers on the data sheet correspond with the numbers shown before each specimen is viewed. Be aware that there are a few cases (3 or 4) that the numbers on the screen do not match those on the data sheet (like 143 instead of 177 or 191 instead of 190). Don't worry, the screen numbers are wrong. Just follow the order as shown and it will match the order of the data sheet.
6. For each specimen, circle the defect type code for the primary, or worst defect you see. Circle 'NO' if no defect is detected. If more than one defect type is noted, mark the secondary, or more minor defect with an 'X'. Don't worry about marking the data sheet for third or fourth, more minor defects. If you are uncertain about whether a weld has a defect, just make your best guess.
7. Try to take frequent breaks. Allow about 2 hours to finish.
8. Please feel free to make any comments on the back of your first data sheet. Thank you for your help!



Exhibit 7.1 (Con'd)

**Visual Weld Inspection Experiment**

Your Name:

Please note any experience in welding, welding inspection and qualifications here:

Defect Type Codes:

NO = None

PS = Porosity, Scattered (4 or more within 1/16" of each other)

PC = Porosity, Cluster (mega-pores)

UC = Undercut

RO = Roughness (Excessive along longitudinal axis)

RA = Re-entrant Angle (Excessive angle between base metal and weld bead surface)

IC = Irregular Contour (Excessive along transverse axis)

Video Segment:

40" Shots (Scale: 1":0.75")

1	NO	PS	PC	UC	RO	RA	IC
2	NO	PS	PC	UC	RO	RA	IC
3	NO	PS	PC	UC	RO	RA	IC
4	NO	PS	PC	UC	RO	RA	IC
5	NO	PS	PC	UC	RO	RA	IC
6	NO	PS	PC	UC	RO	RA	IC
7	NO	PS	PC	UC	RO	RA	IC



detected one. Since the subjects were not experienced in weld inspection, identifying either the primary or secondary defect constituted a correct answer. Similarly, if the subject marked either one of the porosity codes and it was correct, then the general porosity defect type was considered to be correctly identified.

The subjects were allowed to pause the tape during each sequence if desired, since the actual viewing time was so short. The subjects took an average of two hours to complete the experiment. Subjects were encouraged to take breaks to help maintain their concentration while completing this tedious exercise.

### **7.3.3 Direct Viewing**

After viewing the videotapes, the subjects were asked to directly view the specimens. The specimens were randomly numbered and the markings revealing their correct defect type identification codes were covered. The specimens were placed on a table so the subjects could pick them up and orient them in any desired direction. The subjects were asked to identify the defects of the actual specimens in the same manner as in the video viewing portion of the experiment.





## 7.4 Experimental Results

Answers from the subject data sheets were compared with the correct defect codes. A spreadsheet program was used to compare the data for each subject and determine how many defects were correctly identified. A summary data sheet was prepared for each of the nine viewing groups in Table 7.3 (the first eight rows listed plus the direct viewing row). The summary data in Table 7.3 is the average from all six subjects.

The summary data table includes the total percent of defects correctly identified with the primary guess, and both the primary and secondary guesses. The percent of misclassified porosity specimens is identified and added to the total percent correct. For each weld defect type, the percent of defects correctly identified with the primary guess is shown.

Data from the eight video viewing groups was also combined so that the effect of lighting and camera distance could be determined independently of each other. The total results over all distances and lighting conditions is given in Table 7.3. The direct viewing data is also included on the summary sheet. Appendix II shows the summary data for each subject as a percentage of the number of samples in each grouping. The number of specimens identified as having no defects is also included. Roughly 15 to 20 percent were incorrectly identified as having no defects.

To measure the accuracy of the experiment results and to obtain reliable



Table 7.3 Data Summary for Experiment

Distance	Lighting Condition	% Correct Primary Guess Only	% Correct Primary and Secondary Guess	% Correct Primary and Secondary Guesses, and Misclassified Porosity
40"	Side	17.2	20.8	28.1
40"	Above	24.5	30.7	40.1
30"	Side	22.9	28.8	38.5
30"	Above	32.8	37.5	45.3
20"	Side	31.3	39.1	50.5
20"	Above	30.2	36.5	41.9
10"	Side	41.7	47.4	58.9
10"	Above	40.1	49.0	58.5
ALL	Side	28.3	33.9	44.0
ALL	Above	31.9	32.8	49.2
40"	Both	20.8	20.8	34.1
30"	Both	27.9	32.8	41.9
20"	Both	30.7	37.8	49.2
10"	Both	40.9	48.2	58.5
Totals		30.1	36.1	46.0
Direct Viewing		47.4	52.1	62.0



Table 7.3 Data Summary for Experiment (Con'd)

Distance	Lighting Condition	PS	PC	UC	RO	RA	IC
40"	Side	16.7	16.7	11.1	27.8	41.7	5.6
40"	Above	13.9	25.0	22.2	25.0	41.7	30.6
30"	Side	27.8	25.0	30.6	22.2	25.0	8.3
30"	Above	19.4	47.2	27.8	33.3	58.3	27.8
20"	Side	33.3	41.7	33.3	30.6	50.0	11.1
20"	Above	30.6	38.9	36.1	27.8	8.3	25.0
40"	Side	44.4	58.3	55.6	33.3	33.3	19.4
40"	Above	36.1	52.8	75.0	13.9	58.3	16.7
ALL	Side	30.6	35.4	32.6	28.5	37.5	11.1
ALL	Above	25.0	41.0	40.3	25.0	41.7	25.0
40"	Both	15.3	20.8	16.7	26.4	41.7	18.1
30"	Both	23.6	36.1	29.2	27.8	41.7	18.1
20"	Both	31.9	40.3	34.7	29.2	29.2	18.1
40"	Both	40.3	55.6	65.3	23.6	45.8	18.1
Totals		27.8	38.2	36.5	26.7	30.6	18.1
Direct Viewing		38.9	66.7	69.4	41.7	66.7	13.9



conclusions, the "student's t test" was used to compare the means of any two independent variables. If the nine experimental groupings (variations of distance, lighting, and direct viewing) are considered to be independent, then the means of the corresponding dependent measures can be compared using the student's t test. For this experiment, it is desired to determine if any two groupings are considered to be from the same statistical population. If the groupings are in the same population, then it cannot be concluded that there is a difference between the two. If the two groupings form separate populations, then the student's t test can express how different the two groupings are as a level of confidence. If the confidence level is significant, then a justifiable hypothesis can be made on the difference between the two groupings.

References [9] and [79] show how to compute t values associated with student's t distribution and how to find the level of confidence corresponding to the t value. Appendix III shows the computed t values for the comparison of various groupings as shown in Table 7.3. The values compared correspond to different lighting conditions, distances, and direct viewing vs. video viewing. The resulting levels of confidence are also given in Appendix III. Table 7.4 summarizes the levels of confidence given in the appendix and Table 7.5 summarizes the confidence levels by defect type.





Table 7.4 Summary of confidence levels for video viewing

Sequences Compared	% Correct Primary Guess Only	% Correct Primary and Secondary Guess	% Correct Primary and Secondary Guesses, and Misclassified Porosity
Side vs Above Lighting	58.8	61.2	60.1
40" vs 30"	65.2	65.4	67.9
30" vs 20"	56.0	60.8	65.7
20" vs 10"	72.5	72.8	70.7
40" vs 20"	73.1	77.1	81.4
30" vs 10"	74.8	78.0	80.8
40" vs 10"	87.1	89.0	91.3



Table 7.5 Summary of confidence levels for video viewing by defect type

Sequences Compared	PS	PC	UC	RO	RA	IC
Side vs Above Lighting	57.5	58.9	59.8	56.0	54.2	80.2
40" vs 30"	64.9	74.2	63.3	57.5	50.0	50.0
30" vs 20"	59.7	55.4	57.0	51.7	60.6	50.0
20" vs 10"	57.4	65.4	82.2	61.1	65.1	50.0
40" vs 20"	70.3	79.1	68.1	54.3	62.2	50.0
30" vs 10"	66.8	69.0	86.6	57.5	53.1	50.0
40" vs 10"	75.2	82.9	88.2	54.6	53.7	50.0



### 7.4.1 Viewing Distance

Some of the results in Table 7.3 are shown graphically in Figures 7.12 and 7.13. Generally, the closer the camera is to the sample, the higher the number of correctly identified defects. Every subject displayed this trend. The graphs are roughly linear in the region of distances used for the experiment. The accuracy of this hypothesis is supported by confidence levels using the student's t test.

For the following comparisons, computations are based on the number of correct primary, secondary, or misclassified porosity defect guesses. Comparing two distance groupings that were separated by 10 inches (i.e. 40 vs. 30 inches, 30 vs. 20 inches, or 20 vs. 10 inches) the confidence levels are 68%, 65%, and 70%, for an average of 68%. (A confidence level of 50% is the lowest possible, and the highest confidence levels approach 100%.) For a separation of 20 inches (i.e. 40 vs. 20 inches or 30 vs. 10 inches), the average confidence level increases to 81%. For a separation of 30 inches (i.e. 40 vs. 10 inches), the confidence level is 91%. As the distance separation increases, there is more certainty that the trend is accurate. Confidence levels are shown in Table 7.4.

Figure 7.13 shows that the recognition of some defect types is affected by camera distance more than of other types. Specifically, porosity and undercut defect recognition varied significantly with camera distance. The



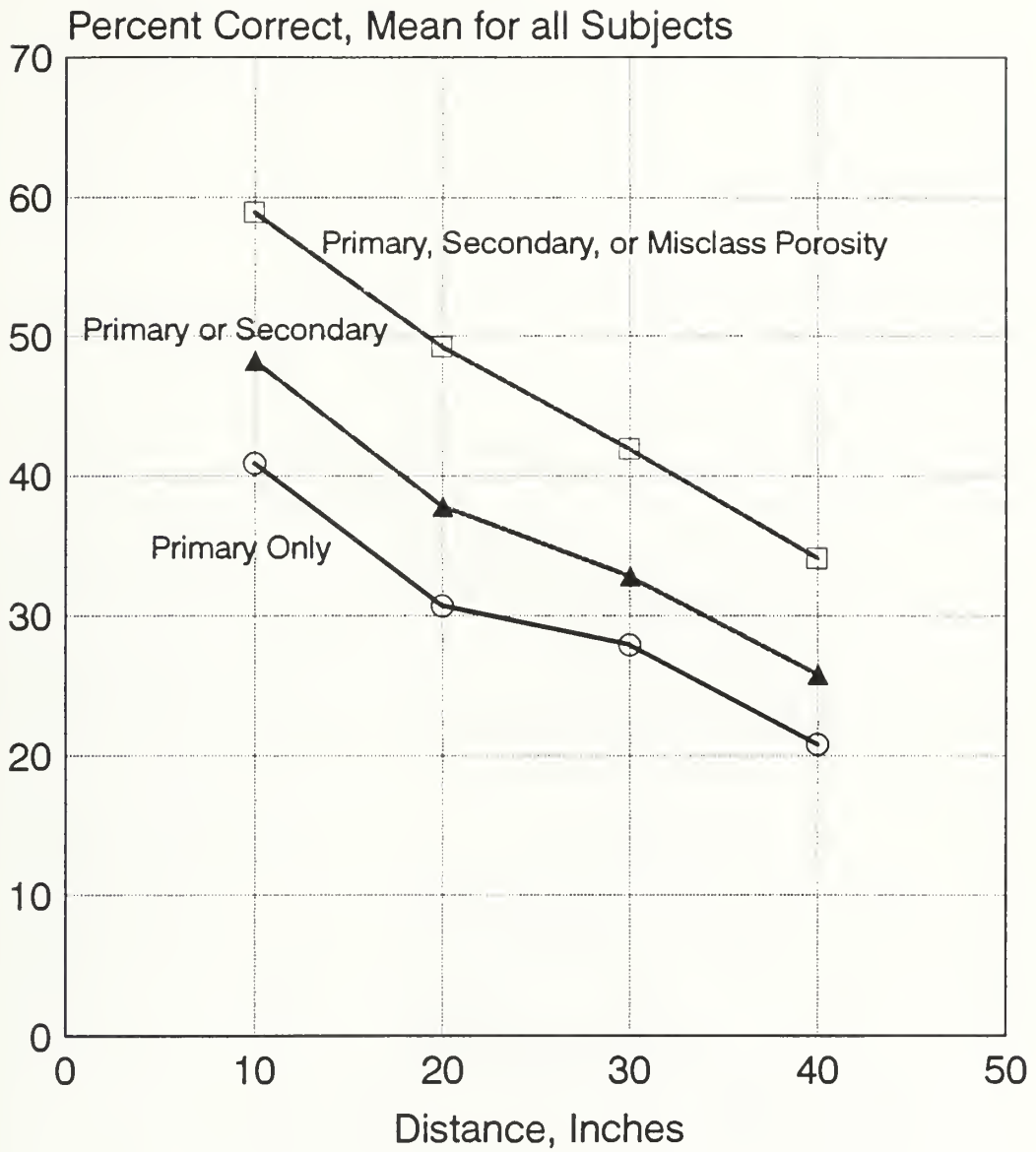

Figure 7.12 Effect of distance on the percent of defects correctly identified





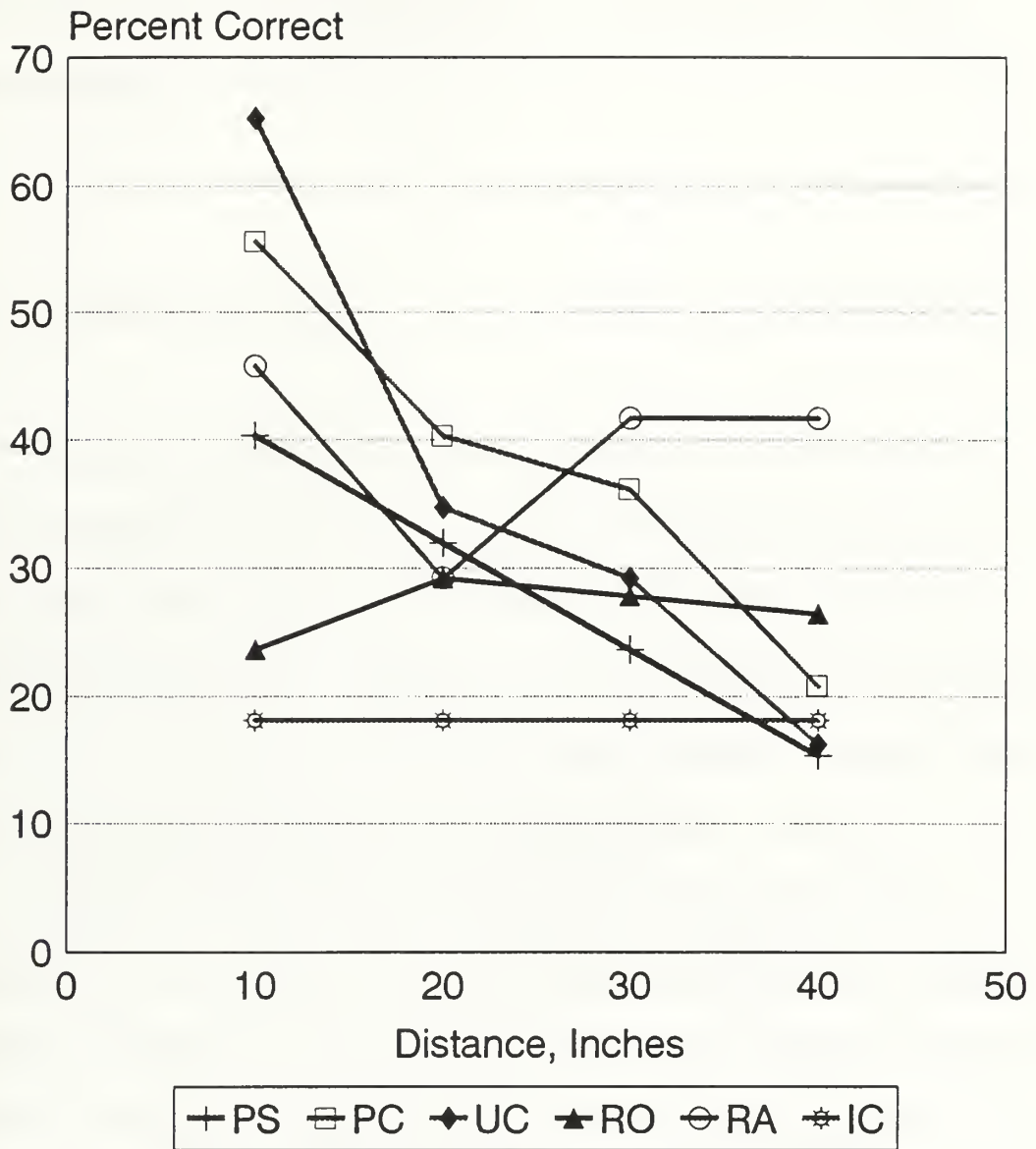

Figure 7.13 Effect of distance on the percent of defects correctly identified by defect type



distance separation confidence levels of these defects were much higher than those of the other defect types, as shown in Table 7.5. Roughness, re-entrant angle, and irregular contour defects were not as significantly affected by camera distance.

#### **7.4.2 Lighting Conditions**

Figure 7.14 displays the percentage of correctly identified defects for both side lighting and above lighting. Statistics are shown for three cases: the primary guess was correct, either the primary or secondary guesses was correct, and either primary, secondary, or misclassified porosity guesses was correct. For all cases, the above-lighting sequences had an average of 4.0% more correctly identified defects than the side-lighting sequences.

Lighting condition affects how well particular defect types can be identified. Shadows cast by features of the defects will vary with the lighting condition. Therefore, it is useful to examine the effects of lighting conditions for individual defect types. For defects that run longitudinally along the weld axis, such as undercuts, irregular contours, and excessive re-entrant angles, one would assume that they would be more easily identified by light shone transversely to the weld axis (above lighting). For defects that run transversely to the weld axis, such as excessive roughness, one would expect longitudinally



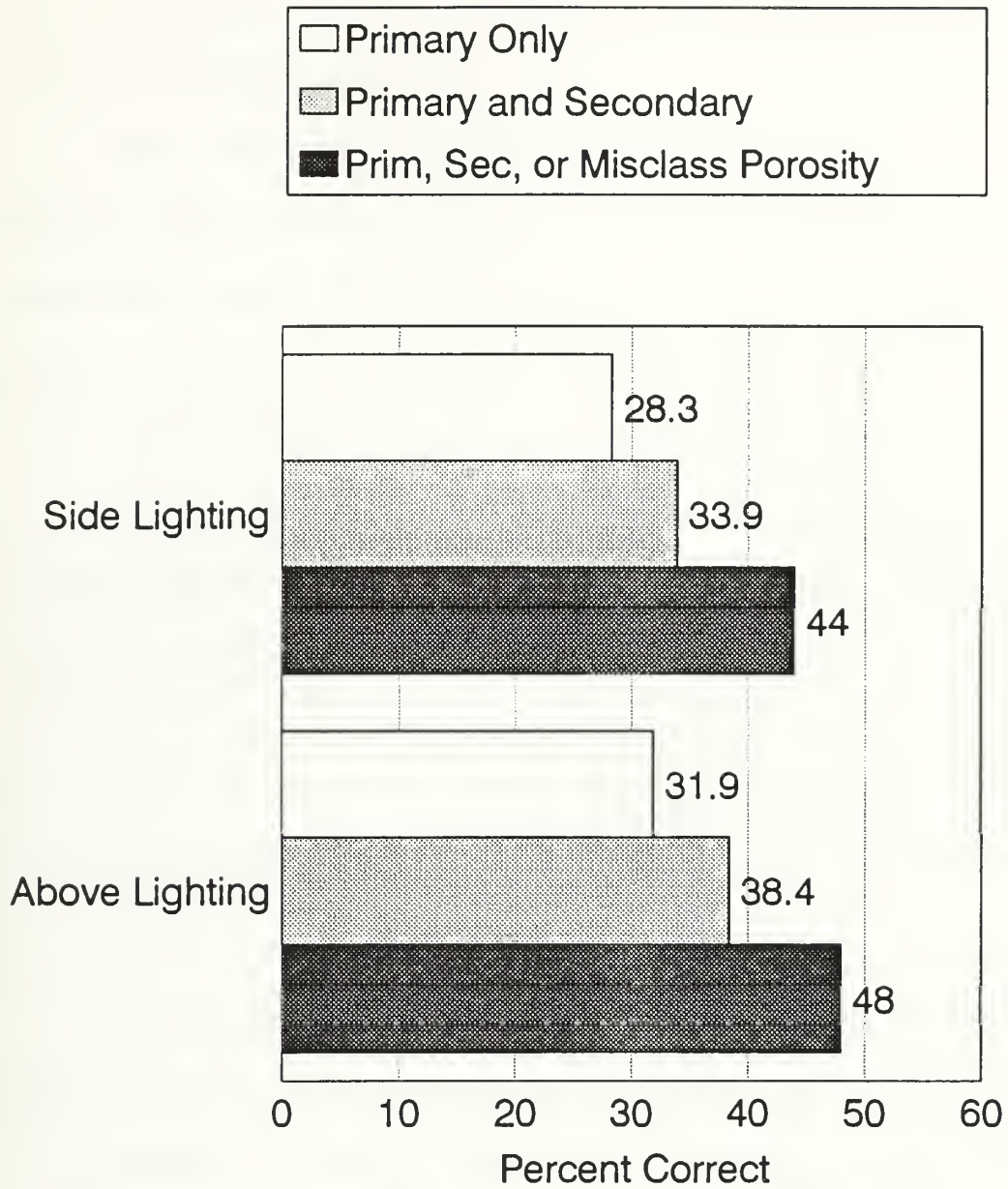

Figure 7.14 Effect of lighting conditions on the percent of defects correctly identified



directed light (side lighting) to enhance the features of the defect. Porosity defects should not be affected by light source direction since they are roughly circular and randomly distributed.

Figure 7.15 displays the percent of correctly identified defects by defect type and lighting condition. The trends predicted above prove to be true in this experiment. The two forms of porosity defects (scattered and clustered) show opposite trends, but the sum of side lighting and above lighting for both porosity types shows the effect of the two lighting conditions to be about equal. Table 7.5 summarizes the confidence levels of these results by defect type. The most significant difference in defect detection with change in lighting conditions occurred for irregular contour defects.

### **7.4.3 Direct Viewing Compared to Video Viewing**

The percentages of correctly identified defects for video viewing and direct viewing is summarized in Figure 7.16. During video viewing, as the camera distance decreases, the weld defects can be seen better and thus there is a higher degree of recognition success. When compared to direct viewing, the video viewing recognition success was less for all distances tested. Video viewing recognition success at a camera distance of 10 inches was closest to that of direct viewing recognition success.





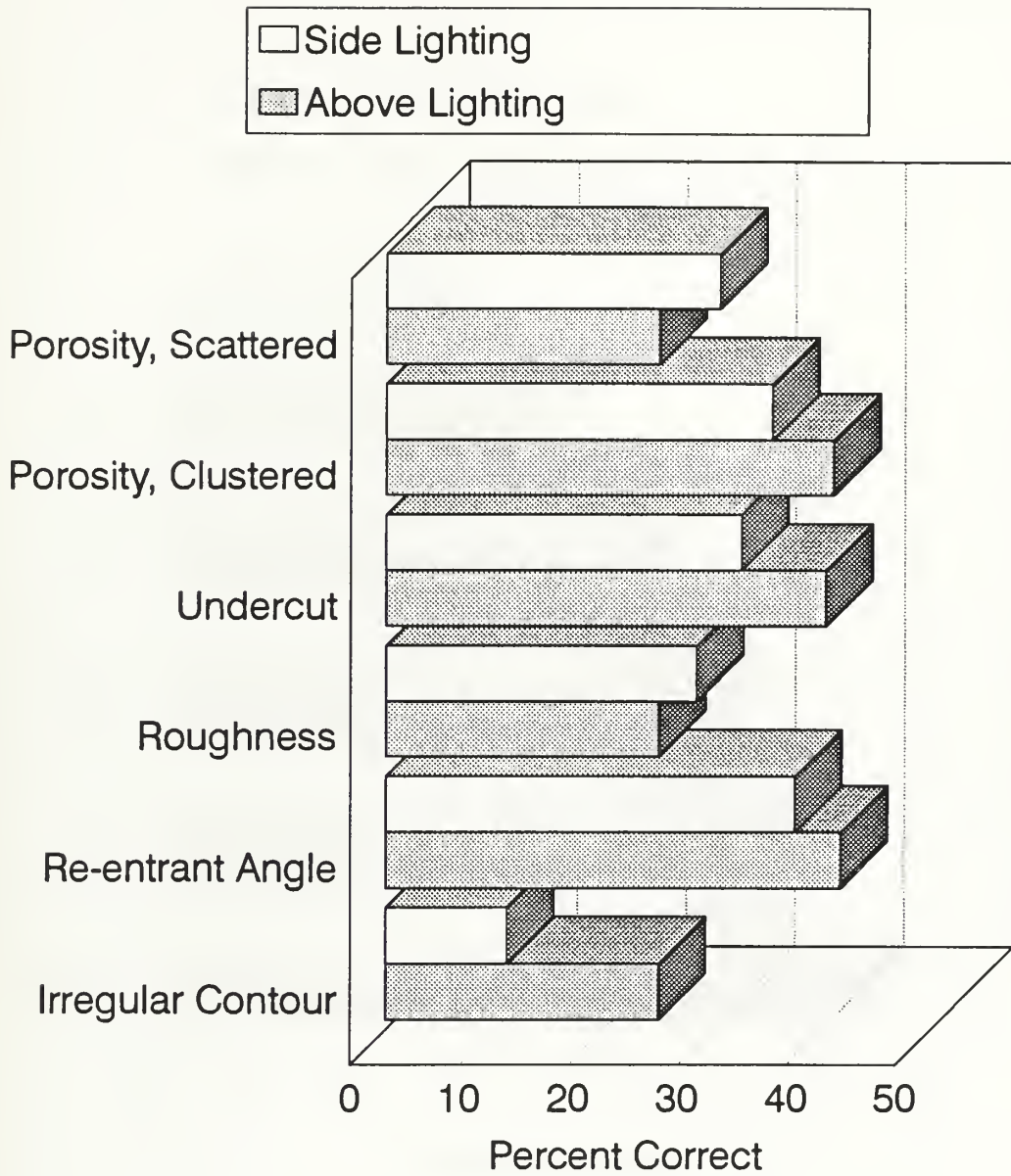

Figure 7.15 Effect of lighting conditions on the percent of defects correctly identified by defect type



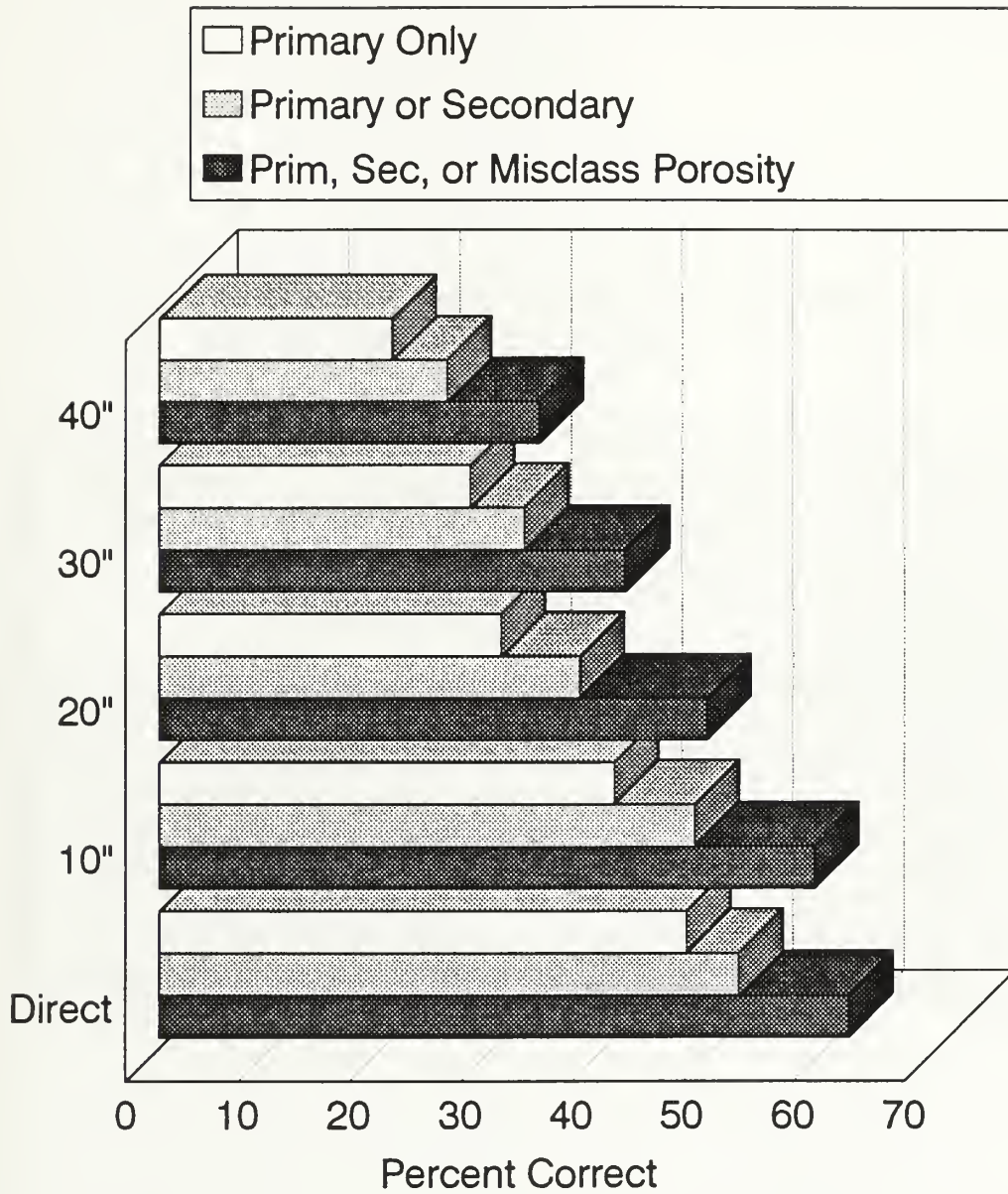

Figure 7.16 Comparison of direct vs. video viewing



Table 7.6 Summary of confidence levels comparing video viewing with direct viewing

Sequences Compared	% Correct Primary Guess Only	% Correct Primary and Secondary Guess	% Correct Primary and Secondary Guesses, and Misclassified Porosity
Direct vs Total	86.4	86.8	87.6
Direct vs 40"	95.0	96.2	97.5
Direct vs 30"	85.5	86.8	69.3
Direct vs 20"	85.7	84.6	81.4
Direct vs 10"	67.0	61.1	59.0



The confidence levels for direct viewing as compared to video viewing at various distances are summarized in Table 7.6. "Total" in the first row of Table 7-6 means the total of all the video viewing results. The results show that direct viewing is most significantly different from video viewing at larger camera distances. The lowest confidence levels were those that compared direct viewing and video viewing at the closest camera distances. Having lower confidence levels between the means of two groupings indicates that the results of the two groupings are more likely to be the same. Therefore, in this experiment, recognition results for direct viewing was most similar to a video viewing distance of 10 inches.

These results imply that although direct viewing has a higher degree of recognition success than any of the video viewing camera distances tested, there may be a closer camera distance at which recognition success of direct viewing and video viewing are the same. But if the camera is too close to the weld, it may not be able to focus properly. If the camera is capable of zooming in very close, there will be a point at which the camera's field of view is too narrow, leading to information loss and a reduction in the number of properly identified weld defects. If the camera system is automated, there is also a tradeoff between the camera's distance from the weld and its speed of travel, or scanning rate. If the camera scans the weld area too quickly, then the human operator will have difficulty in properly identifying the defects. If the scanning is too slow, then precious operational time and money can be wasted.





## Chapter 8: Conclusions

It is evident that once telerobotics and welding in space have been established, the two can be combined into a human supervisory, robot manipulated task. This will allow astronauts to perform exterior repairs and construction without EVA.

There currently exists a wide variety of automated welding sensors that can easily be adapted for welding in remote locations. Although welding itself can be fully automated, remote fabrication also requires weld preparation and post-weld inspection. A human supervisor is needed to make high-level planning decisions and to determine the mission goals. The human supervisor interface should be designed to allow the operator as much control over the process as desired, and yet require little intervention once the operator has given control to the automated system.

The Flight Telerobotic Servicer (FTS) and the Special Purpose Dexterous Manipulator (SPDM) provide examples of a telerobotic platforms that could be adapted for space welding.

The remote weld defect viewing experiment was designed to determine the ability of human operators to recognize weld defects at different camera distances and in different lighting conditions. The results of the video viewing



experiment was also compared to those of directly viewing the weld defects.

Key results are summarized as follows:

1. As the camera distance from the specimen was varied over the range of 40 to 10 inches, the percentage of correctly identified defects increased an average of 8.2% for each 10-inch reduction in camera distance.
2. The ability to recognize certain defect types did not vary considerably with camera distance. Excessive roughness, re-entrant angle, and irregular contour defects were not recognized substantially more often when the camera distance was decreased. The recognition of porosity and undercut defects, on the other hand, improved greatly as camera distance was decreased.
3. Changing the angle of lighting relative to the weld axis did not appreciably change defect recognition success. For the slight variations found, the results indicate that longitudinally staggered defects are better recognized when the light source was directed longitudinally along the weld axis. Conversely, transversely staggered defects were better recognized when the light source was directed transversely along the weld axis.
4. Direct viewing of weld defects had a higher degree of recognition success than video viewing of defects at the camera distances chosen. There may be a



camera distance at which video viewing is comparable to direct viewing, but if the camera is too close to the weld, the slower scanning rate may greatly increase the operational time needed to perform the inspection task.



**Appendix I:**  
**Weld Sample Descriptions and Relationship Between Existing Acceptance  
Standards**





TABLE I

WELD SURFACE CONDITIONS - SEVERITY LEVELS SELECTED  
- BUTTS AND FILLETS -

UNDERCUT

Level O: None present  
Level A: 1/64 in. deep continuous  
Level B: 1/32 in. deep continuous  
Level C: 1/16 in. deep continuous

SCATTERED POROSITY

Level O: None present  
Level A: 4 pores 1/32 in. maximum diameter  
Level B: 4 pores 1/16 in. maximum diameter  
or  
7 pores 3/64 in. maximum diameter  
Level C: 4 pores 1/8 in. maximum diameter  
or  
equivalent area

CLUSTER POROSITY

Level O: None present  
Level A: Multiple pores 1/32 in. maximum diameter within  
1/4 in.  
Level B: Multiple pores within 1/2 in.  
Level C: Multiple pores within 1 in.

**NOTES:**

1. All of the above definitions are per 6 in. of weld.
2. Level O is to be used for each condition to represent a weld which is free of the surface condition under consideration.



TABLE II

SAMPLE CODES FOR PLASTIC WELD REPLICAS

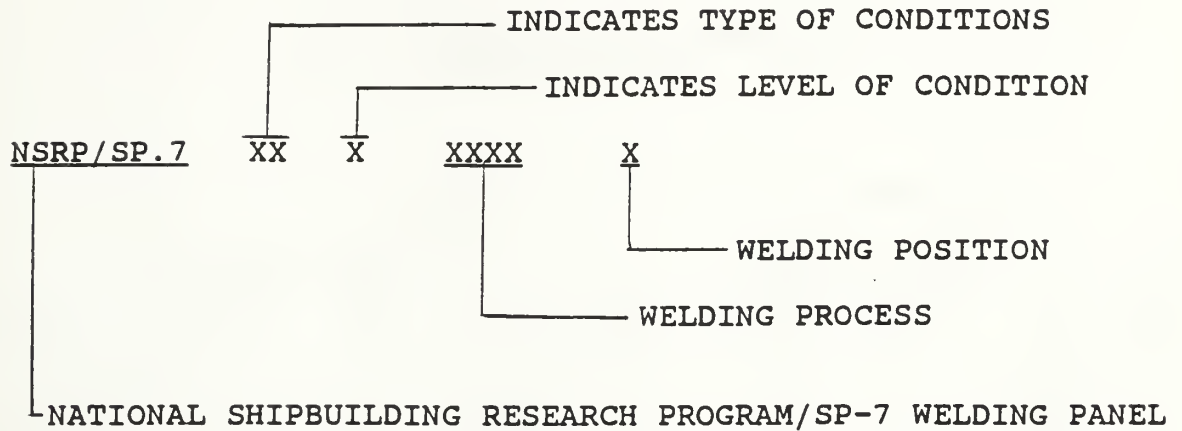

CONDITION TYPE CODES:

PS = POROSITY (SCATTERED)  
PC = POROSITY (CLUSTER)  
UC = UNDERCUT  
RO = ROUGHNESS  
RA = RE-ENTRANT ANGLE  
CX = IRREGULAR CONTOUR

CONDITION LEVEL CODES:

A = LEAST SEVERE LEVEL OF CONDITION ILLUSTRATED  
B = INTERMEDIATE LEVEL OF CONDITION ILLUSTRATED  
C = MOST SEVERE LEVEL OF CONDITION ILLUSTRATED

PROCESS CODES:

SMAW = SHIELDED METAL ARC WELDING  
SAW = SUBMERGED ARC WELDING  
GMAW = GAS METAL ARC WELDING  
FCAW = FLUX CORED ARC WELDING  
UNK = UNKNOWN

POSITION CODES:

F = FLAT  
V = VERTICAL  
O = OVERHEAD  
H = HORIZONTAL  
X = UNKNOWN



**TABLE III**  
**LIST OF PLASTIC WELD REPLICAS**  
**REPRESENTATION**

Project Sponsor	BUTTS*				FILLETTS*			
	Condi- tion Type	Condi- tion Level	Pro- cess	Posi- tion	Condi- tion Type	Condi- tion Level	Pro- cess	Posi- tion
NSRP/SP.7	UC	A	SMAW	F	UC	A	GMAW	O
NSRP/SP.7	UC	B	GMAW	V	UC	B	SMAW	O
NSRP/SP.7	UC	C	SMAW	F	UC	C	SMAW	V
NSRP/SP.7	PS	A	SMAW	F	PS	A	GMAW	F
NSRP/SP.7	PS	B	SMAW	O	PS	B	SMAW	F
NSRP/SP.7	PS	C	SAW	F	PS	C	SMAW	H
NSRP/SP.7	PC	A	SMAW	H	PC	A	SAW	H
NSRP/SP.7	PC	B	GMAW	V	PC	B	GMAW	O
NSRP/SP.7	PC	C	SMAW	H	PC	C	GMAW	V
NSRP/SP.7	CX	A	SMAW	F	CX	A	FCAW	V
NSRP/SP.7	CX	B	UNK	X	CX	B	UNK	X
NSRP/SP.7	CX	C	UNK	X	CX	C	UNK	X
NSRP/SP.7	RO	A	SMAW	F	RO	A	UNK	X
NSRP/SP.7	RO	B	UNK	X	RO	B	UNK	X
NSRP/SP.7	RO	C	FCAW	V	RO	C	UNK	X
NSRP/SP.7	RA				RA			

\* See TABLE II for sample codes



TABLE IV

RELATIONSHIP BETWEEN EXISTING ACCEPTANCE STANDARDS & SELECTED  
 SAMPLES  
 -UNDERCUT-

EXISTING STANDARD	APPLICABLE SAMPLES
AWS D.1.1-90, Sections 10.17.1.5 and 9.25.1.5 Requirements	<u>Level A</u> (1/64 in. undercut) (considered meeting 0.01 inch requirement for butts & fillets from AWS)
Undercut shall be no more than 0.01 in. (0.25mm) deep when its direction is transverse to primary tensile stress in the part that is undercut,	<u>Level B</u> (1/32 in. undercut) for butts and fillets
No more than 1/32 in. (1mm) for all other situations	
AWS D1.1-90, Section 8.15.1.(5) requirements	
For material less than 1 in. thick undercut shall not exceed 1/32" (1mm)	<u>Level B</u> (1/32 in. undercut) for butts and fillets
For material thickness less than 1 in. (25.4mm) a max. 1/16 in. (1.6mm) is permitted for an accumulated strength of 2 in. (50mm) in any 12 in. (305 mm).	<u>Level C</u> (1/16 in. undercut) for butts and fillets
For material equal or greater than 1 in. Undercut shall not exceed 1/16 in. (1.6mm) for any length of weld.	
<u>ASME</u> 1989 Section VIII Div. 1 Para. UW-35 Requirements	
The reduction in thickness shall not exceed 1/32 in. (0.8mm) or 10% of the nominal thickness of the adjoining surface, whichever is less	<u>Level A</u> (1/64 in. undercut) for butts & fillets (5/32 in. ≤ thickness ≤ 5/16 in.)
	<u>Level B</u> (1/32 in. undercut) for butts and fillets (thickness ≥ 5/16" in.)





TABLE IV CONTINUED

-UNDERCUT-

EXISTING STANDARD	APPLICABLE SAMPLES
<p>ASME B31.1, 1989 Para. 136.4.2 (A.2)</p>	<p><u>Level B</u> (1/32 in. undercut) for butts and fillets</p>
<p>Unacceptable - Undercut on surface which is greater than 1/32 in.</p>	
<p>API RA 2A, 1986 Para. 6.4.1 undercut should not exceed 0.01 inch.(0.25mm)</p>	<p><u>Level A</u> (1/64 in. undercut) for butts and fillets</p>
<p>NAVSEA 0900-LP-003-8000, 1967 Paragraph 5.2.6 Requirements</p>	
<p><u>Class 1</u></p>	
<p>The maximum undercut shall be 1/64 inch or 10% of the adjacent base metal thickness, whichever is less.</p>	<p><u>Level A</u> (1/64 in. undercut) for butts &amp; fillets (thickness <math>\geq</math> 5/32 - in.)</p>
<p><u>Class 2 and 3</u></p>	
<p>The maximum undercut shall be 1/32 in. or 10% of the adjacent base metal thickness, whichever is less</p>	<p><u>Level B</u> (1/32 in. undercut) for butts &amp; fillets (thickness <math>\geq</math> 5/16 - in.)</p>
<p>For base metal thicknesses 1/2 in. and greater, undercut up to 1/16 in. is allowed if the accumulated length of undercut exceeding 1/32 - in. does not exceed 15% of the joint length or 12 inches in 36 inches length of weld, whichever is less.</p>	<p><u>Level B</u> (1/32 in. undercut) (Note 1) <u>Level C</u> (1/16 in. undercut) (Note 1) for butts &amp; fillets</p>



TABLE IV CONTINUED

-UNDERCUT-

EXISTING STANDARD	APPLICABLE SAMPLES
MIL-STD-1689 (SH), 1983 Para. 8.3 Requirement	<u>Level B</u> 1/32 in. undercut) (Note 1) <u>Level C</u> (1/16 in. undercut) (Note 1) for butts and fillets

Note: (1) These weld samples illustrate the magnitude of the defects. The permissible distribution is specified in the specification.



TABLE IV CONTINUED

- SCATTERED POROSITY -

EXISTING STANDARD	APPLICABLE SAMPLES
AWS D1.1-90	
Sections 10.17.1.6 and .7 and 8.15.1 (6) and (8) Requirements	
<u>Fillet Welds</u>	
The sum of diameters of piping porosity (Note 3) in fillet welds shall not exceed 3/8 in. (10mm) in any linear inch of weld and shall not exceed 3/4 in. (19.0mm) in any 12 in. (305mm) length of weld.	<u>Level B</u> (4 pores 1/16in.) (Note 1) for fillets  <u>Level C</u> (4 pores 1/8 in.) (Note 1) for fillets
<u>Butt Welds</u>	
Complete joint penetration groove welds in butt joints transverse to the direction of computed tensile stress shall have no piping porosity. For all other groove welds piping porosity shall not exceed 3/8 in. (9.5mm) in any linear inch of weld and shall not exceed 3/4 in. (19mm) in any 12 in. (305mm) length of weld.	<u>Level O</u> (Note 2)  <u>Level B</u> (4 pores 1/16in.) Note 1) for butts



TABLE IV CONTINUED

- SCATTERED POROSITY -

EXISTING STANDARD	APPLICABLE SAMPLES
<p>AWS D1.1-90 Section 9.25.1.6 and .8 Requirements</p>	
<p><u>Fillet Welds</u></p>	
<p>The frequency of piping porosity in fillet welds shall not exceed one in each 4 in. (100 mm) of weld length and the maximum diameter shall not exceed 3/32 in. (2 mm). Exception for fillet welds connecting stiffness to web, the sum of the diameters of piping porosity shall not exceed 3/8 in. (10 mm) in any linear inch of weld and shall not exceed 3/4 in. (19mm) in any 12 in. (305 mm) length of weld.</p>	<p><u>Level B</u> (4 pores 1/16 in.) (Note 1) for fillets</p> <p><u>Level C</u> (4 pores 1/8 in.) (Note 1) for fillets</p>
<p><u>Butt Weld</u></p>	
<p>Complete joint penetration groove welds in butt joints transverse to the direction of computed tensile stress shall have no piping porosity. For all other groove welds, the frequency of piping porosity shall not exceed one in 4 in. (100 mm) of length and the maximum diameter shall not exceed 3/32 in. (2 mm).</p>	<p><u>Level O (Note 2)</u></p> <p><u>Level B</u> (4 pores 1/16 in.) (Note 1) for butts</p> <p><u>Level C</u> (4 pores 1/8 in.) (Note 1) for butts</p>
<p>AME Section VIII Division 1, 1989 Appendix 8 Para. 8.3, 8.4 Requirements</p>	
<p>All surfaces to be examined shall be free of:</p>	
<p>Four or more rounded defects in line separated by 1/16 in. (1.6mm) or less (edge to edge).</p>	<p><u>Level A</u> (4 pores 1/32 in.) (Note 1) for butts &amp; fillets</p>





TABLE IV CONTINUED

- SCATTERED POROSITY -

EXISTING STANDARD	APPLICABLE SAMPLES
NAVSEA 0900-LP-003-8000 Paragraph 5.3.2.2 requirements	<u>Level A</u> (4 pores 1/32 in.) (Note 1) for butts and fillets
Linearly aligned rounded indications as defined in 2.19 (four or more indications in a line any one of which is separated from the adjacent indicating by less than 1/16" or D whichever is greater, where D is the major diameter of the larger of the adjacent indications), shall be cause for rejection if one or more of the indications is 1/32-inch diameter or greater for <u>Class 1</u>	
1/16 inch or greater for <u>Class 2</u>	<u>Level B</u> (4 pores 1/16in.) Note 1) for butts and fillets
3/16 inch or greater for <u>Class 3</u>	<u>Level C</u> (4 pores 1/8 in.) (Note 1) for butts and fillets

- Notes: (1) These weld samples illustrate the magnitude of the defect. The permissible distribution is specified the specification.
- (2) Presence of this defect is not permissible. One perfect sample would apply to all cases when the presence of any type of defect is not allowed.
- (3) 1/32 in. (1mm) or greater is added between piping porosity and in fillet welds in Para 8.15.1 (6) and (8).



TABLE V

SUMMARY OF ACCEPTANCE STANDARDS  
(IRREGULAR CONTOUR)

---

MIL-STD-1689 (SH)

Para. 14.3.1

Welds should be free of sharp  
irregularities between beads

---

NAVSEA

0900-LP-003-8000

Surface Inspection

not addressed

---

AWS D1.1-90

Structural Welding Code

not addressed

---

ABS, 1990

Section 30A.5.8.a

Steel Vessel Rules

The surfaces of welds... are to be  
regular and uniform.

---

ASME

Section VIII Div. 1

Pressure Vessels

not addressed

---

ASME, 1989

Section I

Power Boilers

not addressed

---

API RP 2A, 1986

Fixed Offshore Platforms

not addressed

---



TABLE VI  
 SUMMARY OF ACCEPTANCE STANDARDS  
 (ROUGHNESS)

MIL-STD-1689 (sh) Para. 14.3.1 Fabrication, Welding and Inspection.	Welds shall be free of sharp irregularities between beads
NAVSEA 09--LP-003-8000 Surface Inspection	not addressed
AWS D1.1-90 Structural Welding Code	not addressed
ABS, 1991 Section 30A.5.8.a Steel Vessel Rules	The surfaces of the welds... are to be regular and uniform.
ASME 1989 Section VIII Div. 1 Pressure Vessels	As-welded surfaces are permitted; however, the surface of welds shall be sufficiently free from coarse ripples, grooves, overlaps abrupt ridges and valleys.
ASME, 1989 Section I PW35 Para. 35.1 Power Boilers	As-welded surfaces are permitted; however, the surface of the welds shall be sufficiently free from coarse ripples, grooves, overlaps, abrupt ridges, and valleys to avoid stress raisers.
API RP2A, 1986 Fixed Offshore Platforms	not addressed



TABLE VII

SUMMARY OF ACCEPTANCE STANDARDS

(RE-ENTRANT ANGLE)

MIL-STD-1689 (SH) Para. 8.3.1 Fabrication, Welding and Inspection	Except as required for NDT, the as-deposited surfaces at the weld edge shall be acceptable provided they do not form a re-entrant angle less than 90 degrees with the base plate.
NAVSEA 0900-LP-003-8000 Para.5.2.1.6 Surface Inspection	When required..., the contour of welds, with the exception of undercut within specification allowances, shall blend smoothly and gradually into the base metal.
AWS D.1.1-90 Para. 3.6.2 Structural Welding Code	In the case of butt.., the reinforcement .... shall have gradual transition to the plane of the base metal surface.
ABS, 1991 30A.5.8a Section 30.5.8a Steel Vessels Rules	The surface of the welds are to be..... reasonably free from.... overlap.
ASME, 1989 Section I Power Boilers	not addressed
Section VIII Div. 1 Pressure Vessels	not addressed
API RP 2A, 1986 Para. 6.4.1 Fixed Offshore Platforms	Weld profiles... should merge smoothly with the base metal of both brace and chord.





**Appendix II:**  
**Summary Data Sheets for Experimental Subjects**



All subjects # Subjects Distance	Lighting: 6	Primary Defect Correct?	Secondary Defect Correct?	Pri or Sec Defect Correct?	Misclass. Porosity Type	Pri, Sec, or Mis. Poros. Correct?	Primary No Defects
40°	Side	17.2	3.6	20.8	7.3	28.1	18.8
40°	Above	24.5	6.3	30.7	9.4	40.1	18.8
30°	Side	22.9	5.2	28.1	10.4	38.5	10.4
30°	Above	32.8	4.7	37.5	7.8	45.3	20.8
20°	Side	31.3	7.8	39.1	11.5	50.5	13.0
20°	Above	30.2	6.3	36.5	11.5	47.9	25.0
10°	Side	41.7	5.7	47.4	11.5	58.9	16.1
10°	Above	40.1	8.9	49.0	9.9	58.9	15.6
ALL	Side	28.3	5.6	33.9	10.2	44.0	14.6
ALL	Above	31.9	6.5	38.4	9.6	48.0	20.1
40°	Both	20.8	4.9	25.8	8.3	34.1	18.8
30°	Both	27.9	4.9	32.8	9.1	41.9	15.6
20°	Both	30.7	7.0	37.8	11.5	49.2	19.0
10°	Both	40.9	7.3	48.2	10.7	58.9	15.9
Totals:		30.1	6.1	36.1	9.9	46.0	17.3
Direct View		47.4	4.7	52.1	9.9	62.0	19.3



All subjects		Primary Porosity Scattered	Primary Porosity Clustered	Primary Undercut	Primary Roughness	Primary Re-entrant Angle	Primary Irregular Contour
Distance	Lighting:						
40°	Side	16.7	16.7	11.1	27.8	41.7	5.6
40°	Above	13.9	25.0	22.2	25.0	41.7	30.6
30°	Side	27.8	25.0	30.6	22.2	25.0	8.3
30°	Above	19.4	47.2	27.8	33.3	58.3	27.8
20°	Side	33.3	41.7	33.3	30.6	50.0	11.1
20°	Above	30.6	38.9	36.1	27.8	8.3	25.0
10°	Side	44.4	58.3	55.6	33.3	33.3	19.4
10°	Above	36.1	52.8	75.0	13.9	58.3	16.7
ALL	Side	30.6	35.4	32.6	28.5	37.5	11.1
ALL	Above	25.0	41.0	40.3	25.0	41.7	25.0
40°	Both	15.3	20.8	16.7	26.4	41.7	18.1
30°	Both	23.6	36.1	29.2	27.8	41.7	18.1
20°	Both	31.9	40.3	34.7	29.2	29.2	18.1
10°	Both	40.3	55.6	65.3	23.6	45.8	18.1
Totals:		27.8	38.2	36.5	26.7	39.6	18.1
Direct Viewing:		38.9	66.7	69.4	41.7	66.7	13.9

Mean for 4 subjects		Secondary Porosity Scattered	Secondary Porosity Clustered	Secondary Undercut	Secondary Roughness	Secondary Re-entrant Angle	Secondary Irregular Contour
Distance	Lighting:						
40°	Side	16.7	0.0	0.0	0.0	12.5	8.3
40°	Above	4.2	8.3	8.3	16.7	12.5	8.3
30°	Side	12.5	4.2	4.2	4.2	25.0	8.3
30°	Above	16.7	0.0	4.2	8.3	12.5	4.2
20°	Side	25.0	16.7	4.2	4.2	0.0	12.5
20°	Above	20.8	4.2	8.3	0.0	12.5	12.5
10°	Side	0.0	4.2	8.3	12.5	37.5	8.3
10°	Above	29.2	4.2	4.2	20.8	12.5	8.3
ALL	Side	13.5	6.3	4.2	5.2	18.8	9.4
ALL	Above	17.7	4.2	6.3	11.5	12.5	8.3
40°	Both	10.4	4.2	4.2	8.3	12.5	8.3
30°	Both	14.6	2.1	4.2	6.3	18.8	6.3
20°	Both	22.9	10.4	6.3	2.1	6.3	12.5
10°	Both	14.6	4.2	6.3	16.7	25.0	8.3
Totals:		15.6	5.2	5.2	8.3	15.6	8.9
Direct Viewing:		12.5	0.0	0.0	0.0	25.0	16.7



Subject 1		Primary Defect Correct?	Secondary Defect Correct?	Pri or Sec Defect Correct?	Misclass. Porosity Type	Pri, Sec, or Mis. Poros. Correct?	Primary No Defects
Distance	Lighting:						
40°	Side	9.4	0.0	9.4	15.6	25.0	34.4
40°	Above	18.8	0.0	18.8	9.4	28.1	37.5
30°	Side	21.9	0.0	21.9	6.3	28.1	37.5
30°	Above	18.8	9.4	28.1	12.5	40.6	31.3
20°	Side	25.0	6.3	31.3	12.5	43.8	25.0
20°	Above	28.1	6.3	34.4	9.4	43.8	25.0
10°	Side	40.6	3.1	43.8	9.4	53.1	31.3
10°	Above	28.1	3.1	31.3	18.8	50.0	25.0
ALL	Side	24.2	2.3	26.6	10.9	37.5	32.0
ALL	Above	23.4	4.7	28.1	12.5	40.6	29.7
40°	Both	14.1	0.0	14.1	12.5	26.6	35.9
30°	Both	20.3	4.7	25.0	9.4	34.4	34.4
20°	Both	26.6	6.3	32.8	10.9	43.8	25.0
10°	Both	34.4	3.1	37.5	14.1	51.6	28.1
Totals:		23.8	3.5	27.3	11.7	39.1	30.9
Direct View		46.9	6.3	53.1	9.4	62.5	18.8

Subject 2		Primary Defect Correct?	Secondary Defect Correct?	Pri or Sec Defect Correct?	Misclass. Porosity Type	Pri, Sec, or Mis. Poros. Correct?	Primary No Defects
Distance	Lighting:						
40°	Side	9.4	0.0	9.4	6.3	15.6	6.3
40°	Above	21.9	0.0	21.9	6.3	28.1	18.8
30°	Side	9.4	0.0	9.4	9.4	18.8	6.3
30°	Above	12.5	0.0	12.5	9.4	21.9	31.3
20°	Side	18.8	0.0	18.8	15.6	34.4	15.6
20°	Above	21.9	0.0	21.9	3.1	25.0	31.3
10°	Side	34.4	0.0	34.4	3.1	37.5	25.0
10°	Above	40.6	0.0	40.6	0.0	40.6	15.6
ALL	Side	18.0	0.0	18.0	8.6	26.6	13.3
ALL	Above	24.2	0.0	24.2	4.7	28.9	24.2
40°	Both	15.6	0.0	15.6	6.3	21.9	12.5
30°	Both	10.9	0.0	10.9	9.4	20.3	18.8
20°	Both	20.3	0.0	20.3	9.4	29.7	23.4
10°	Both	37.5	0.0	37.5	1.6	39.1	20.3
Totals:		21.1	0.0	21.1	6.6	27.7	18.8
Direct View		50.0	0.0	50.0	3.1	53.1	31.3





Subject 3		Primary Defect Correct?	Secondary Defect Correct?	Pri or Sec Defect Correct?	Misclass. Porosity Type	Pri, Sec, or Mis. Poros. Correct?	Primary No Defects
Distance	Lighting:						
40°	Side	34.4	0.0	34.4	6.3	40.6	15.6
40°	Above	46.9	0.0	46.9	12.5	59.4	9.4
30°	Side	46.9	0.0	46.9	3.1	50.0	18.8
30°	Above	56.3	0.0	56.3	3.1	59.4	18.8
20°	Side	53.1	0.0	53.1	0.0	53.1	18.8
20°	Above	50.0	0.0	50.0	0.0	50.0	28.1
10°	Side	62.5	0.0	62.5	3.1	65.6	21.9
10°	Above	62.5	0.0	62.5	3.1	65.6	21.9
ALL	Side	49.2	0.0	49.2	3.1	52.3	18.8
ALL	Above	53.9	0.0	53.9	4.7	58.6	19.5
40°	Both	40.6	0.0	40.6	9.4	50.0	12.5
30°	Both	51.6	0.0	51.6	3.1	54.7	18.8
20°	Both	51.6	0.0	51.6	0.0	51.6	23.4
10°	Both	62.5	0.0	62.5	3.1	65.6	21.9
Totals:		51.6	0.0	51.6	3.9	55.5	19.1
Direct View		62.5	0.0	62.5	0.0	62.5	18.8

Subject 4		Primary Defect Correct?	Secondary Defect Correct?	Pri or Sec Defect Correct?	Misclass. Porosity Type	Pri, Sec, or Mis. Poros. Correct?	Primary No Defects
Distance	Lighting:						
40°	Side	21.9	3.1	25.0	0.0	25.0	28.1
40°	Above	25.0	15.6	40.6	9.4	50.0	18.8
30°	Side	18.8	6.3	25.0	15.6	40.6	0.0
30°	Above	37.5	3.1	40.6	3.1	43.8	21.9
20°	Side	31.3	12.5	43.8	12.5	56.3	6.3
20°	Above	25.0	3.1	28.1	28.1	56.3	28.1
10°	Side	34.4	6.3	40.6	21.9	62.5	12.5
10°	Above	25.0	9.4	34.4	18.8	53.1	18.8
ALL	Side	26.6	7.0	33.6	12.5	46.1	11.7
ALL	Above	28.1	7.8	35.9	14.8	50.8	21.9
40°	Both	23.4	9.4	32.8	4.7	37.5	23.4
30°	Both	28.1	4.7	32.8	9.4	42.2	10.9
20°	Both	28.1	7.8	35.9	20.3	56.3	17.2
10°	Both	29.7	7.8	37.5	20.3	57.8	15.6
Totals:		27.3	7.4	34.8	13.7	48.4	16.8
Direct View		40.6	3.1	43.8	21.9	65.6	18.8



Subject 5		Primary Defect Correct?	Secondary Defect Correct?	Pri or Sec Defect Correct?	Misclass. Porosity Type	Pri, Sec, or Mis. Poros. Correct?	Primary No Defects
Distance	Lighting:						
40°	Side	12.5	9.4	21.9	9.4	31.3	12.5
40°	Above	15.6	9.4	25.0	12.5	37.5	12.5
30°	Side	25.0	6.3	31.3	12.5	43.8	0.0
30°	Above	43.8	3.1	46.9	9.4	56.3	6.3
20°	Side	34.4	12.5	46.9	18.8	65.6	6.3
20°	Above	31.3	12.5	43.8	18.8	62.5	18.8
10°	Side	43.8	12.5	56.3	12.5	68.8	3.1
10°	Above	43.8	18.8	62.5	9.4	71.9	3.1
ALL	Side	28.9	10.2	39.1	13.3	52.3	5.5
ALL	Above	33.6	10.9	44.5	12.5	57.0	10.2
40°	Both	14.1	9.4	23.4	10.9	34.4	12.5
30°	Both	34.4	4.7	39.1	10.9	50.0	3.1
20°	Both	32.8	12.5	45.3	18.8	64.1	12.5
10°	Both	43.8	15.6	59.4	10.9	70.3	3.1
Totals:		31.3	10.5	41.8	12.9	54.7	7.8
Direct View		43.8	9.4	53.1	15.6	68.8	6.3

Subject 6		Primary Defect Correct?	Secondary Defect Correct?	Pri or Sec Defect Correct?	Misclass. Porosity Type	Pri, Sec, or Mis. Poros. Correct?	Primary No Defects
Distance	Lighting:						
40°	Side	15.6	9.4	25.0	6.3	31.3	15.6
40°	Above	18.8	12.5	31.3	6.3	37.5	15.6
30°	Side	15.6	18.8	34.4	15.6	50.0	0.0
30°	Above	28.1	12.5	40.6	9.4	50.0	15.6
20°	Side	25.0	15.6	40.6	9.4	50.0	6.3
20°	Above	25.0	15.6	40.6	9.4	50.0	18.8
10°	Side	34.4	12.5	46.9	18.8	65.6	3.1
10°	Above	40.6	21.9	62.5	9.4	71.9	9.4
ALL	Side	22.7	14.1	36.7	12.5	49.2	6.3
ALL	Above	28.1	15.6	43.8	8.6	52.3	14.8
40°	Both	17.2	10.9	28.1	6.3	34.4	15.6
30°	Both	21.9	15.6	37.5	12.5	50.0	7.8
20°	Both	25.0	15.6	40.6	9.4	50.0	12.5
10°	Both	37.5	17.2	54.7	14.1	68.8	6.3
Totals:		25.4	14.8	40.2	10.5	50.8	10.5
Direct View		40.6	9.4	50.0	9.4	59.4	21.9



Subject 1		Primary Porosity Scattered	Primary Porosity Clustered	Primary Undercut	Primary Roughness	Primary Re-entrant Angle	Primary Irregular Contour
Distance	Lighting:						
40°	Side	0.0	16.7	0.0	16.7	50.0	0.0
40°	Above	16.7	33.3	33.3	0.0	50.0	0.0
30°	Side	33.3	16.7	33.3	16.7	50.0	0.0
30°	Above	16.7	16.7	33.3	16.7	50.0	0.0
20°	Side	50.0	16.7	33.3	0.0	50.0	16.7
20°	Above	33.3	0.0	50.0	33.3	0.0	33.3
10°	Side	33.3	33.3	83.3	16.7	50.0	33.3
10°	Above	33.3	0.0	83.3	16.7	50.0	0.0
ALL	Side	29.2	20.8	37.5	12.5	50.0	12.5
ALL	Above	25.0	12.5	50.0	16.7	37.5	8.3
40°	Both	8.3	25.0	16.7	8.3	50.0	0.0
30°	Both	25.0	16.7	33.3	16.7	50.0	0.0
20°	Both	41.7	8.3	41.7	16.7	25.0	25.0
10°	Both	33.3	16.7	83.3	16.7	50.0	16.7
Totals:		27.1	16.7	43.8	14.6	43.8	10.4
Direct View		50.0	33.3	100.0	33.3	100.0	0.0

Subject 2		Primary Porosity Scattered	Primary Porosity Clustered	Primary Undercut	Primary Roughness	Primary Re-entrant Angle	Primary Irregular Contour
Distance	Lighting:						
40°	Side	16.7	0.0	0.0	16.7	50.0	0.0
40°	Above	33.3	16.7	16.7	0.0	50.0	33.3
30°	Side	33.3	16.7	0.0	0.0	0.0	0.0
30°	Above	16.7	0.0	16.7	0.0	0.0	33.3
20°	Side	16.7	50.0	0.0	33.3	0.0	0.0
20°	Above	33.3	50.0	16.7	0.0	0.0	16.7
10°	Side	66.7	50.0	16.7	50.0	0.0	0.0
10°	Above	66.7	66.7	66.7	0.0	50.0	0.0
ALL	Side	33.3	29.2	4.2	25.0	12.5	0.0
ALL	Above	37.5	33.3	29.2	0.0	25.0	20.8
40°	Both	25.0	8.3	8.3	8.3	50.0	16.7
30°	Both	25.0	8.3	8.3	0.0	0.0	16.7
20°	Both	25.0	50.0	8.3	16.7	0.0	8.3
10°	Both	66.7	58.3	41.7	25.0	25.0	0.0
Totals:		35.4	31.3	16.7	12.5	18.8	10.4
Direct View		50.0	83.3	50.0	50.0	50.0	16.7



Subject 3		Primary Porosity Scattered	Primary Porosity Clustered	Primary Undercut	Primary Roughness	Primary Re-entrant Angle	Primary Irregular Contour
Distance	Lighting:						
40°	Side	33.3	16.7	66.7	50.0	50.0	0.0
40°	Above	16.7	16.7	83.3	50.0	100.0	50.0
30°	Side	50.0	50.0	83.3	33.3	50.0	16.7
30°	Above	50.0	66.7	50.0	50.0	100.0	50.0
20°	Side	83.3	50.0	66.7	50.0	100.0	0.0
20°	Above	83.3	66.7	66.7	16.7	50.0	16.7
10°	Side	100.0	83.3	83.3	16.7	100.0	16.7
10°	Above	83.3	83.3	83.3	16.7	100.0	33.3
ALL	Side	66.7	50.0	75.0	37.5	75.0	8.3
ALL	Above	58.3	58.3	70.8	33.3	87.5	37.5
40°	Both	25.0	16.7	75.0	50.0	75.0	25.0
30°	Both	50.0	58.3	66.7	41.7	75.0	33.3
20°	Both	83.3	58.3	66.7	33.3	75.0	8.3
10°	Both	91.7	83.3	83.3	16.7	100.0	25.0
Totals:		62.5	54.2	72.9	35.4	81.3	22.9
Direct View		83.3	100.0	83.3	16.7	100.0	16.7

Subject 4		Primary Porosity Scattered	Primary Porosity Clustered	Primary Undercut	Primary Roughness	Primary Re-entrant Angle	Primary Irregular Contour
Distance	Lighting:						
40°	Side	33.3	16.7	0.0	50.0	50.0	0.0
40°	Above	16.7	33.3	0.0	33.3	50.0	33.3
30°	Side	0.0	16.7	33.3	33.3	0.0	16.7
30°	Above	16.7	50.0	16.7	50.0	100.0	33.3
20°	Side	16.7	33.3	16.7	33.3	100.0	33.3
20°	Above	0.0	16.7	33.3	50.0	0.0	33.3
10°	Side	16.7	33.3	33.3	66.7	0.0	33.3
10°	Above	16.7	0.0	66.7	0.0	50.0	33.3
ALL	Side	16.7	25.0	20.8	45.8	37.5	20.8
ALL	Above	12.5	25.0	29.2	33.3	50.0	33.3
40°	Both	25.0	25.0	0.0	41.7	50.0	16.7
30°	Both	8.3	33.3	25.0	41.7	50.0	25.0
20°	Both	8.3	25.0	25.0	41.7	50.0	33.3
10°	Both	16.7	16.7	50.0	33.3	25.0	33.3
Totals:		14.6	25.0	25.0	39.6	43.8	27.1
Direct View		33.3	16.7	50.0	66.7	50.0	33.3





Subject 5		Primary Porosity Scattered	Primary Porosity Clustered	Primary Undercut	Primary Roughness	Primary Re-entrant Angle	Primary Irregular Contour
Distance	Lighting:						
40°	Side	0.0	16.7	0.0	33.3	50.0	0.0
40°	Above	0.0	16.7	0.0	33.3	0.0	33.3
30°	Side	50.0	33.3	0.0	33.3	50.0	0.0
30°	Above	16.7	66.7	33.3	50.0	100.0	33.3
20°	Side	16.7	33.3	66.7	50.0	50.0	0.0
20°	Above	16.7	50.0	33.3	50.0	0.0	16.7
10°	Side	33.3	66.7	83.3	50.0	0.0	0.0
10°	Above	16.7	83.3	83.3	33.3	50.0	0.0
ALL	Side	25.0	37.5	37.5	41.7	37.5	0.0
ALL	Above	12.5	54.2	37.5	41.7	37.5	20.8
40°	Both	0.0	16.7	0.0	33.3	25.0	16.7
30°	Both	33.3	50.0	16.7	41.7	75.0	16.7
20°	Both	16.7	41.7	50.0	50.0	25.0	8.3
10°	Both	25.0	75.0	83.3	41.7	25.0	0.0
Totals:		18.8	45.8	37.5	41.7	37.5	10.4
Direct View		16.7	83.3	66.7	50.0	50.0	0.0

Subject 6		Primary Porosity Scattered	Primary Porosity Clustered	Primary Undercut	Primary Roughness	Primary Re-entrant Angle	Primary Irregular Contour
Distance	Lighting:						
40°	Side	16.7	33.3	0.0	0.0	0.0	33.3
40°	Above	0.0	33.3	0.0	33.3	0.0	33.3
30°	Side	0.0	16.7	33.3	16.7	0.0	16.7
30°	Above	0.0	83.3	16.7	33.3	0.0	16.7
20°	Side	16.7	66.7	16.7	16.7	0.0	16.7
20°	Above	16.7	50.0	16.7	16.7	0.0	33.3
10°	Side	16.7	83.3	33.3	0.0	50.0	33.3
10°	Above	0.0	83.3	66.7	16.7	50.0	33.3
ALL	Side	12.5	50.0	20.8	8.3	12.5	25.0
ALL	Above	4.2	62.5	25.0	25.0	12.5	29.2
40°	Both	8.3	33.3	0.0	16.7	0.0	33.3
30°	Both	0.0	50.0	25.0	25.0	0.0	16.7
20°	Both	16.7	58.3	16.7	16.7	0.0	25.0
10°	Both	8.3	83.3	50.0	8.3	50.0	33.3
Totals:		8.3	56.3	22.9	16.7	12.5	27.1
Direct View		0.0	83.3	66.7	33.3	50.0	16.7



Subject 1		Secondary Porosity Scattered	Secondary Porosity Clustered	Secondary Undercut	Secondary Roughness	Secondary Re-entrant Angle	Secondary Irregular Contour
Distance	Lighting:						
40°	Side	0.0	0.0	0.0	0.0	0.0	0.0
40°	Above	0.0	0.0	0.0	0.0	0.0	0.0
30°	Side	0.0	0.0	0.0	0.0	0.0	0.0
30°	Above	16.7	0.0	0.0	0.0	50.0	16.7
20°	Side	16.7	0.0	0.0	16.7	0.0	0.0
20°	Above	33.3	0.0	0.0	0.0	0.0	0.0
10°	Side	0.0	0.0	0.0	0.0	50.0	0.0
10°	Above	16.7	0.0	0.0	0.0	0.0	0.0
ALL	Side	4.2	0.0	0.0	4.2	12.5	0.0
ALL	Above	16.7	0.0	0.0	0.0	12.5	4.2
40°	Both	0.0	0.0	0.0	0.0	0.0	0.0
30°	Both	8.3	0.0	0.0	0.0	25.0	8.3
20°	Both	25.0	0.0	0.0	8.3	0.0	0.0
10°	Both	8.3	0.0	0.0	0.0	25.0	0.0
Totals:		10.4	0.0	0.0	2.1	12.5	2.1
Direct View		16.7	0.0	0.0	0.0	0.0	16.7

Subject 4		Secondary Porosity Scattered	Secondary Porosity Clustered	Secondary Undercut	Secondary Roughness	Secondary Re-entrant Angle	Secondary Irregular Contour
Distance	Lighting:						
40°	Side	16.7	0.0	0.0	0.0	0.0	0.0
40°	Above	0.0	16.7	33.3	16.7	0.0	16.7
30°	Side	0.0	16.7	0.0	0.0	0.0	16.7
30°	Above	16.7	0.0	0.0	0.0	0.0	0.0
20°	Side	16.7	33.3	0.0	0.0	0.0	16.7
20°	Above	0.0	0.0	16.7	0.0	0.0	0.0
10°	Side	0.0	0.0	16.7	0.0	0.0	16.7
10°	Above	0.0	16.7	16.7	16.7	0.0	0.0
ALL	Side	8.3	12.5	4.2	0.0	0.0	12.5
ALL	Above	4.2	8.3	16.7	8.3	0.0	4.2
40°	Both	8.3	8.3	16.7	8.3	0.0	8.3
30°	Both	8.3	8.3	0.0	0.0	0.0	8.3
20°	Both	8.3	16.7	8.3	0.0	0.0	8.3
10°	Both	0.0	8.3	16.7	8.3	0.0	8.3
Totals:		6.3	10.4	10.4	4.2	0.0	8.3
Direct View		0.0	0.0	0.0	0.0	0.0	16.7



Subject 5		Secondary Porosity Scattered	Secondary Porosity Clustered	Secondary Undercut	Secondary Roughness	Secondary Re-entrant Angle	Secondary Irregular Contour
Distance	Lighting:						
40°	Side	16.7	0.0	0.0	0.0	0.0	33.3
40°	Above	0.0	0.0	0.0	33.3	50.0	0.0
30°	Side	0.0	0.0	0.0	0.0	50.0	16.7
30°	Above	0.0	0.0	0.0	16.7	0.0	0.0
20°	Side	16.7	16.7	16.7	0.0	0.0	16.7
20°	Above	16.7	0.0	16.7	0.0	0.0	33.3
10°	Side	0.0	16.7	0.0	0.0	100.0	16.7
10°	Above	50.0	0.0	0.0	33.3	0.0	16.7
ALL	Side	8.3	8.3	4.2	0.0	37.5	20.8
ALL	Above	16.7	0.0	4.2	20.8	12.5	12.5
40°	Both	8.3	0.0	0.0	16.7	25.0	16.7
30°	Both	0.0	0.0	0.0	8.3	25.0	8.3
20°	Both	16.7	8.3	16.7	0.0	0.0	25.0
10°	Both	25.0	8.3	0.0	16.7	50.0	16.7
Totals:		12.5	4.2	4.2	10.4	25.0	16.7
Direct View		16.7	0.0	0.0	0.0	50.0	16.7

Subject 6		Secondary Porosity Scattered	Secondary Porosity Clustered	Secondary Undercut	Secondary Roughness	Secondary Re-entrant Angle	Secondary Irregular Contour
Distance	Lighting:						
40°	Side	33.3	0.0	0.0	0.0	50.0	0.0
40°	Above	16.7	16.7	0.0	16.7	0.0	16.7
30°	Side	50.0	0.0	16.7	16.7	50.0	0.0
30°	Above	33.3	0.0	16.7	16.7	0.0	0.0
20°	Side	50.0	16.7	0.0	0.0	0.0	16.7
20°	Above	33.3	16.7	0.0	0.0	50.0	16.7
10°	Side	0.0	0.0	16.7	50.0	0.0	0.0
10°	Above	50.0	0.0	0.0	33.3	50.0	16.7
ALL	Side	33.3	4.2	8.3	16.7	25.0	4.2
ALL	Above	33.3	8.3	4.2	16.7	25.0	12.5
40°	Both	25.0	8.3	0.0	8.3	25.0	8.3
30°	Both	41.7	0.0	16.7	16.7	25.0	0.0
20°	Both	41.7	16.7	0.0	0.0	25.0	16.7
10°	Both	25.0	0.0	8.3	41.7	25.0	8.3
Totals:		33.3	6.3	6.3	16.7	25.0	8.3
Direct View		16.7	0.0	0.0	0.0	50.0	16.7



**Appendix III:**

**Student's t Test Distribution Calculations and Confidence Levels**





t Values:	Primary Defect Correct?	Secondary Defect Correct?	Pri or Sec Defect Correct?	Misclass. Porosity Type	Pri, Sec. or Mis. Poros. Correct?	Primary No Defects
Slide vs. Above	0.2313	0.1074	0.2946	0.0902	0.2654	0.4548
40" vs. 30"	0.4041	0.0000	0.4096	0.1764	0.4867	0.2152
30" vs. 20"	0.1608	0.2432	0.2819	0.2918	0.4203	0.2722
20" vs. 10"	0.6373	0.0262	0.6453	0.0760	0.5741	0.2797
40" vs. 20"	0.6570	0.2482	0.8043	0.3912	0.9925	0.0236
30" vs. 10"	0.7169	0.2458	0.8415	0.1995	0.9650	0.0178
40" vs. 10"	1.2961	0.2499	1.4243	0.3010	1.6024	0.2129
Direct vs. Total	1.2548	0.1854	1.2762	0.0000	1.3287	0.1718
Direct vs. 40"	2.0128	0.0375	2.2072	0.1822	2.5112	0.0421
Direct vs. 30"	1.2004	0.0364	1.2757	0.0906	1.4454	0.2672
Direct vs. 20"	1.2130	0.3043	1.1491	0.1435	0.9891	0.0265
Direct vs. 10"	0.4589	0.2971	0.2906	0.0728	0.2375	0.2708

t Values:	Primary Porosity Scattered	Primary Porosity Clustered	Primary Undercut	Primary Roughness	Primary Re-entrant Angle	Primary Irregular Contour
Slide vs. Above	0.1995	0.2326	0.2561	0.1605	0.1188	0.9366
40" vs. 30"	0.3974	0.6946	0.3506	0.0561	0.0000	0.0000
30" vs. 20"	0.2537	0.1466	0.1859	0.0614	0.2781	0.0000
20" vs. 10"	0.1964	0.4096	1.0275	0.2905	0.4032	0.0000
40" vs. 20"	0.5605	0.8904	0.4923	0.1204	0.3205	0.0000
30" vs. 10"	0.4525	0.5200	1.2687	0.1971	0.0927	0.0000
40" vs. 10"	0.7334	1.0629	1.3686	0.1285	0.1068	0.0000
Direct vs. Total	0.3166	0.7675	1.1680	0.6755	0.7644	0.2749
Direct vs. 40"	0.7563	1.3300	1.4983	0.6122	0.6847	0.2490
Direct vs. 30"	0.4468	0.7841	1.4336	0.5661	0.5839	0.2490
Direct vs. 20"	0.1729	0.6787	1.1817	0.5477	0.9616	0.2490
Direct vs. 10"	0.0319	0.2424	0.1492	0.8455	0.5342	0.2107

t Values:	Secondary Porosity Scattered	Secondary Porosity Clustered	Secondary Undercut	Secondary Roughness	Secondary Re-entrant Angle	Secondary Irregular Contour
Slide vs. Above	0.2106	0.2840	0.2673	0.5071	0.3043	0.0921
40" vs. 30"	0.2085	0.3627	0.0000	0.1992	0.3043	0.2306
30" vs. 20"	0.3343	0.8607	0.2058	0.5130	0.6742	0.4972
20" vs. 10"	0.3689	0.6175	0.0000	0.8182	0.7596	0.3043
40" vs. 20"	0.5953	0.6175	0.2058	0.7596	0.3627	0.3043
30" vs. 10"	0.0000	0.3627	0.2058	0.5495	0.2306	0.2306
40" vs. 10"	0.2454	0.0000	0.2058	0.4385	0.4767	0.0000
Direct vs. Total	0.1837	1.1070	1.1070	1.1359	0.3068	0.6101
Direct vs. 40"	0.1426	0.9129	0.5976	1.1180	0.4082	0.6455
Direct vs. 30"	0.1049	0.5976	0.5976	0.8519	0.1992	0.8895
Direct vs. 20"	0.4990	1.1532	0.8519	0.5976	0.6396	0.2673
Direct vs. 10"	0.1238	0.9129	0.8519	0.9535	0.0000	0.6455



Confidence Levels	Primary Defect Correct?	Secondary Defect Correct?	Pri or Sec Defect Correct?	Misclass. Porosity Type	Pri, Sec, or Mis. Poros. Correct?	Primary No Defects
Side vs. Above	58.8	53.7	61.2	53.0	60.1	66.9
40" vs. 30"	65.2	49.0	65.4	56.6	67.9	58.2
30" vs. 20"	56.0	59.3	60.8	61.1	65.7	60.4
20" vs. 10"	72.5	50.2	72.8	52.4	70.7	60.7
40" vs. 20"	73.1	59.5	77.1	64.7	81.4	50.1
30" vs. 10"	74.8	59.4	78.0	57.5	80.8	49.8
40" vs. 10"	87.1	59.5	89.0	61.5	91.3	58.1
Direct vs. Total	86.4	57.0	86.8	49.0	87.6	56.4
Direct vs. 40"	95.0	50.7	96.2	56.8	97.5	50.9
Direct vs. 30"	85.5	50.6	86.8	53.0	89.3	60.2
Direct vs. 20"	85.7	61.6	84.6	55.3	81.4	50.2
Direct vs. 10"	67.0	61.3	61.1	52.2	59.0	60.3

Confidence Levels	Primary Porosity Scattered	Primary Porosity Clustered	Primary Undercut	Primary Roughness	Primary Re-entrant Angle	Primary Irregular Contour
Side vs. Above	57.5	58.9	59.8	56.0	54.2	80.2
40" vs. 30"	64.9	74.2	63.3	51.5	49.0	49.0
30" vs. 20"	59.7	55.4	57.0	51.7	60.6	49.0
20" vs. 10"	57.4	65.4	82.2	61.1	65.1	49.0
40" vs. 20"	70.3	79.1	68.1	54.3	62.2	49.0
30" vs. 10"	66.8	69.0	86.6	57.5	53.1	49.0
40" vs. 10"	75.2	82.9	88.2	54.6	53.7	49.0
Direct vs. Total	62.0	76.1	84.9	73.6	76.0	60.5
Direct vs. 40"	75.8	87.6	90.0	71.8	73.9	59.5
Direct vs. 30"	66.6	76.5	89.1	70.4	71.0	59.5
Direct vs. 20"	56.5	73.7	85.1	69.9	80.8	59.5
Direct vs. 10"	50.4	59.2	55.5	78.1	69.5	58.0

Confidence Levels	Secondary Porosity Scattered	Secondary Porosity Clustered	Secondary Undercut	Secondary Roughness	Secondary Re-entrant Angle	Secondary Irregular Contour
Side vs. Above	58.0	60.8	60.2	68.6	61.6	53.1
40" vs. 30"	57.9	63.7	49.0	57.5	61.6	58.8
30" vs. 20"	62.7	78.4	57.8	68.8	73.6	68.3
20" vs. 10"	63.9	72.0	49.0	77.4	75.9	61.6
40" vs. 20"	71.3	72.0	57.8	75.9	63.7	61.6
30" vs. 10"	49.0	63.7	57.8	69.9	58.8	58.8
40" vs. 10"	59.4	49.0	57.8	66.3	67.6	49.0
Direct vs. Total	56.9	83.8	83.8	84.3	61.7	71.8
Direct vs. 40"	55.2	79.7	71.4	84.0	65.3	72.8
Direct vs. 30"	53.6	71.4	71.4	78.2	57.5	79.1
Direct vs. 20"	68.3	84.6	78.2	71.4	72.6	60.2
Direct vs. 10"	54.4	79.7	78.2	80.6	49.0	72.8



## Bibliography

1. Agapakis, J. E., "Vision-Aided Remote Robotic Welding.", MIT PhD Thesis, Ocean Engineering Department, February 1985.
2. Agapakis, J. E., et al., "Joint Tracking and Adaptive Robotic Welding using Vision Sensing of the Weld Joint Geometry.", *Welding Journal*, Nov. 1986, pp 33-41.
3. Agapakis, J. E., Wittles, N., Masubuchi, K., "Automated Visual Weld Inspection for Robotic Welding Fabrication.", *Proceedings of the International Conference on Automation and Robotisation in Welding and Allied Processes*, Strasbourg, France, 2-3 Sept. 1985.
4. Agrawal, B. N., "Design of Geosynchronous Spacecraft," Prentice-Hall Inc., 1986.
5. Andary, J.F., K. Halterman, C. Hewitt, and P. Sebellious. "The Flight Telerobotic Servicer (FTS): NASA's First Operational Robotic System.", *American Institute of Aeronautics and Astronautics (AIAA) Paper N90-25537*.
6. Andary, J.F., D.R. Hewitt, and S.W. Hinkal. "The Flight Telerobotic Servicer Tinman Concept: System Design Drivers and Task Analysis.", *AIAA Paper N90-29822*.
7. Andary, J.F., S.W. Hinkal, and J.G. Watzin. "Design Concept for the Flight Telerobotic Servicer (FTS).", *AIAA Paper N89-19870*.
8. Anderson, D. E., "EVA/Telerobotic Space Vehicle Construction Techniques - Results of Neutral Buoyancy Testing.", *Proceedings from the conference: Welding in Space and the Construction of Space Vehicles by Welding*, New Carrollton, Maryland, September 24-26, 1991, pp. 81.
9. Ang, A., and Tang, W., "Probability Concepts in Engineering Planning and Design, Volume I - Basic Principles.", *John Wiley & Sons, Inc.*, 1975.
10. Anonymous, "First Annual Workshop on Space Operations, Automation, and Robotics (SOAR '87).", *Proceedings of a workshop at the Lyndon B. Johnson Space Center, August 5-7, 1987, NASA Conference Publication 2491, NASA STI Branch, 1987*.
11. Anonymous, "Proceedings from the Conference: Welding in Space and the Construction of Space Vehicles by Welding, September 24-26 1991, New



Carrollton, Maryland, USA.", American Welding Society, Inc., 1991.

12. Anonymous, "The Role of Cost Analysis in Spacecraft Development.", SAE 1990 Transactions, Vol. 99 Journal of Aerospace, Section 1, Part 2, SAE, 1991.

13. Anonymous, "Space Station Freedom Media Handbook.", NASA Public Affairs Office, May 1992.

14. Anonymous, "Welding Automation and Robotics Conference Proceedings.", Indianapolis, Indiana, 12-13 March, 1985, American Welding Society, 1985.

15. Anonymous, "Weld Quality, the Role of Computers.", Proceedings of the International Conference on Improved Weldment Control with Special Reference to Computer Technology, Vienna, Austria, 4-5 July 1988, International Institute of Welding, 1988.

16. Anonymous, "Weld Inspection.", Second Edition, Prepared by the AWS Committee on Methods of Inspection, American Welding Society, 1980.

17. Beattie, R. J., Cheng, S. K., and Logue, P. S., "The Use of Vision Sensors in Multipass Welding Applications.", *Welding Journal*, Nov. 1988, pp 28-33.

18. Becker R., and K. Betzold, "Computer Aided Design of Eddy Current Weld Inspection Optimization of a Multifrequency Approach.", paper from: "Weld Quality, the Role of Computers.", Proceedings of the International Conference on Improved Weldment Control with Special Reference to Computer Technology, Vienna, Austria, 4-5 July 1988, International Institute of Welding, 1988, pp. 87.

19. Benaroya, H., and Ettouney, M., "Design Codes for Lunar Structures.", Engineering, Construction, and Operations in Space III, Space '92, Proceedings of the Third International Conference, Denver, Colorado, 31 May - 4 June 1992. Vol. I, pp 1, American Society of Civil Engineers, 1992.

20. Bille, M. A., "The Affordable Space Platform: The STS External Tank.", Engineering, Construction, and Operations in Space III, Space '92, Proceedings of the Third International Conference, Denver, Colorado, 31 May - 4 June 1992. Vol. I, pp 945, American Society of Civil Engineers, 1992.

21. Boillot, J. P., et al, "Adaptive Welding by Fiber Optic Thermographic Sensing: An Analysis of Thermal and Instrumental Considerations.", *Welding Journal*, Research Supplement, July 1985, pp 209-s to 217-s.





22. Boorsma D. K., "Interaset: A Natural Language Interface for Teleoperated Robotic Assembly of the EASE Space Structure.", from: "Proceedings of the Conference on Space Telerobotics.", held at JPL on 31 January, 1989, Vol. 5, NASA CR-186858, N90-29885, pp. 103, 1989.
23. Bulatzev, A. R., "Erection and Welding of Large-Sized Structures in Space.", Proceedings from the conference: Welding in Space and the Construction of Space Vehicles by Welding, New Carrollton, Maryland, September 24-26, 1991, pp. 70.
24. Buzan, F. T., Sheridan, T. B., etal, "Adjustable Impedance, Force Feedback, and Command Language Aids for Telerobotics.", from: "Proceedings of the Conference on Space Telerobotics.", held at JPL on 31 January, 1989, Vol. 1, NASA CR-186858, N90-29007, pp. 81, 1989.
25. Carney, J., and Stelzer, E., "Industrial Optical Sensing, Critical Reviews of Optical Science and Technology.", SPIE Vol. 961, The Society of Photo-Optical Instrumentation Engineers, 1988.
26. Cary, Howard B., "Modern Welding Technology.", 2nd Edition, Prentice Hall, 1989.
27. Conway, L., etal, "Tele-Autonomous Systems: New Methods for Projecting and Coordinating Intelligent Action at a Distance.", from: "Proceedings of the Conference on Space Telerobotics.", held at JPL on 31 January, 1989, Vol. 3, NASA CR-186858, N90-29794, pp. 147, 1989.
28. Dzhanibekov, V. A., "Welding Equipment for Space Applications.", Proceedings from the conference: Welding in Space and the Construction of Space Vehicles by Welding, New Carrollton, Maryland, September 24-26, 1991, pp. 49.
29. Eagar, Thomas W. "Prospectus for Development of a Rational Welding Technology for Fabrication in Space.", March 4 1987. Materials Processing Center, M.I.T. Photocopy.
30. Fazio, Giovanni G., Ph. D., "Hazards of Space: Vacuum, Temperature, and Microgravity.", Chapter 1 of the Course Notes for the Fundamentals of Space Life Sciences at the Massachusetts Institute of Technology (Course #16.354J), 1992.
31. Garrett, Harry B. "Space Environments and the Effects on Space Automation and Robotics.", AIAA Paper N90-25543.



32. Goodman, B. A., and Litman, D. J., "Plan Recognition for Space Telerobotics.", from: "Proceedings of the Conference on Space Telerobotics.", held at JPL on 31 January, 1989, Vol. 1, NASA CR-186858, N90-29036, pp. 395, 1989.
33. Grimson, E., and Patil, S., "AI in the 1980's and Beyond, An MIT Survey.", The MIT Press, Cambridge, Massachusetts, 1987.
34. Hagman, Jane A., "Space Construction.", Proceedings of a conference sponsored by OAST at NASA Langley Research Center in Hampton, Virginia, August 6-7, 1986, NASA Conference Publication 2490, NASA STIO, 1987.
35. Hairr, J, and Klang, E., "Structural Considerations in the Design of a Mars Mission Aerobrake.", Engineering, Construction, and Operations in Space III, Space '92, Proceedings of the Third International Conference, Denver, Colorado, 31 May - 4 June 1992. Vol., pp. 873, American Society of Civil Engineers, 1992.
36. Haninger, E. R., and Richter, P. J., "Conceptual Design of Modules for a Lunar Base.", Engineering, Construction, and Operations in Space III, Space '92, Proceedings of the Third International Conference, Denver, Colorado, 31 May - 4 June 1992. Vol. I, pp 100, American Society of Civil Engineers, 1992.
37. Iliff, Richard. "SDIO Robotics in Space Applications.", AIAA Paper N90-25514.
38. Iwata, Tsutomu, Mitsushige Oda, and Ryoichi Imai. "Next Generation Space Robot.", AIAA Paper N90-29899.
39. Jacoby, B. R., "Fundamental Mechanisms Affecting Friction Welding Under Vacuum.", M.I.T. Dual M.S. Thesis in Naval Architecture and Marine Engineering (Ocean Engineering Dept.) and Mechanical Engineering, June 1991.
40. Jensen, Dean G., Susan C. Adam, James H. Stramler, and Robert P. Wilmington. "Telepresence and Space Station Freedom Workstation Operations.", AIAA Paper N90-25527.
41. Johnsen, E. G., "Human Factors Applications in Teleoperator Design and Operation.", Wiley-Interscience, New York, 1971.
42. Kan, Edwin P., John T. Tower, George W. Hunka, and Glenn J. VanSant. "The JPL Telerobot Operator Control Station: Part I -Hardware.", AIAA Paper N90-29049.



43. Kanne, W. R. Jr., "Remote Reactor Repair: GTA Weld Cracking Caused by Entrapped Helium.", *Welding Journal*, August 1988, pp 33-39.
44. Kinard, W. H., et al, "Degradation of Materials Properties in Space-Overview of LDEF (Long Duration Exposure Facility).", *Proceedings from the conference: Welding in Space and the Construction of Space Vehicles by Welding*, New Carrollton, Maryland, September 24-26, 1991.
45. Lane, J. D., "Robotic Welding. -(International trends in manufacturing technology).", IFS (Publications) Ltd., UK, 1987.
46. Lane, J. D., "Robotic Welding State of the Art", paper from: "Robotic Welding -(International trends in manufacturing technology).", IFS (Publications) Ltd., UK, 1987.
47. Langenburg, K. J., et al, "Holographic Imaging of Cracks in Welds.", paper from: "Weld Quality, the Role of Computers.", *Proceedings of the International Conference on Improved Weldment Control with Special Reference to Computer Technology*, Vienna, Austria, 4-5 July 1988, International Institute of Welding, 1988, pp. 97.
48. Lapchinskii, V. F., et al, "Peculiarities and Future Development of Space Welding.", *Proceedings from the conference: Welding in Space and the Construction of Space Vehicles by Welding*, New Carrollton, Maryland, September 24-26, 1991, pp. 12.
49. Lee, G. K. F., et al, "On-Orbit Assembly of Large Space Structures: A Mars Aerobrake Mock-up Study.", *Engineering, Construction, and Operations in Space III, Space '92, Proceedings of the Third International Conference*, Denver, Colorado, 31 May - 4 June 1992. Vol. I, pp 999, American Society of Civil Engineers, 1992.
50. Levin, George M., and Harry O. Erwin, Jr. "An Overview of the Office of Space Flight Satellite Servicing Program Plan.", Paper IAF 87-35, 38th Congress of International Astronautical Association, Brighton U.K., October 1987. *Acta Astronautica* 18 (1988):55-61.
51. Lobanov, L. M., and Pivtorak, V. A., "Holographic NDT Examination of Welded Structures.", *Proceedings from the conference: Welding in Space and the Construction of Space Vehicles by Welding*, New Carrollton, Maryland, September 24-26, 1991, pp. 220.
52. Lopez, L., et al, "Design of a Monitor and Simulation Terminal (Master) for



Space Station Telerobotics and Telescience.", from: "Proceedings of the Conference on Space Telerobotics.", held at JPL on 31 January, 1989, Vol. 2, NASA CR-186858, N90-29051, pp. 75, 1989.

53. Malin, J. T., et al, "Making Intelligent Systems Team Players: Case Studies and Design Issues, Volume 1: Human- Computer Interaction Design.", NASA Technical Memorandum 104788, N91-30713, September 1991.

54. Martin, H. L., and Kuban, D. P., "Teleoperated Robotics in Hostile Environments.", Robotics International of SME Publications Development Dept., 1985.

55. Mason, C. A., "Teleoperation and Control.", Proceedings of the International Symposium, 12-15 July 1988, Bristol, England, IFS Ltd, June 1988.

56. Massimino, M. J., "Effects of Force and Visual Feedback on Space Teleoperation with Policy Implications.", MIT Masters Thesis, Mechanical Engineering Department, 1988.

57. Masubuchi, Koichi, John E. Agapakis, Andrew DeBiccari, and Christopher Von Alt. "Feasibility of Remotely Manipulated Welding in Space - A Step in the Development of Novel Joining Technologies-.", Final report submitted to NASA under contract no. NASW-3740, September 1983.

58. Matijevic, J.R. The Telerobot Testbed: An Architecture for Remote Servicing.", AIAA Paper N90-25538.

59. McCain, Harry G. "The Flight Telerobotic Servicer Project: A Technical Overview.", AIAA Paper 90-29821.

60. McGough, M.S., Austin, W. E., and Knetl, G. J., "Underwater Plasma Arc Cutting in Three Mile Island's Reactor.", Welding Journal, July 1989, pp 22-27.

61. McGough, M.S., and Burgoon, C., "Visual Monitoring of Remote Welding Operations.", Welding Journal, Dec 1990, pp 23-28.

62. Middle, J.,E., "Component Design for Robot Welding.", paper from: "Exploiting Robots in Arc Welded Fabrication.", The Welding Institute, 1989, pp. 155.

63. Mittman, David et al. "The JPL/KSC Telerobotic Inspection Demonstration.", AIAA Paper N90-22312.





64. Nagabushanam, Ravikumar R., "Management Guidelines for the Evaluation and Selection of the Welding Technologies for Use in Outer Space.", M.I.T. M.S. Thesis in Ocean Systems Management (Ocean Engineering Dept.), August 1991.
65. North, T. H., "Advanced Joining Technologies - Proceedings of the International Institute of Welding Congress on Joining Research, July 1990.", Chapman and Hall, New York, 1990.
66. Ostrovsky, O. E., "Perspectives of Use of Hot Hollow Cathode Welding in Space Conditions.", Space Welding Workshop, C.I.S. Space Engineering Workshop, University of Alabama in Huntsville, August 25-28, 1992.
67. Piotrowski III, J. A., and Randolph, W. T., "Robotic Welding, a Guide to Selection and Application.", Robotics International of SME, Publications Development Dept., 1987.
68. Reeves, R. E., et al, "Expert System Technology - an Avenue to an Intelligent Weld Process Control System.", Welding Journal, June 1988, pp 33-41.
69. Rodriguez, G., and Seraji, H., "Proceedings of the Conference on Space Telerobotics.", held at JPL on 31 January, 1989, Volumes 1, 2, 3, and 5, NASA CR-186858, N90-29780, 1989.
70. Rokhlin, S. I., and Guu, A. C., "Computerized Radiographic Sensing and Control of an Arc Welding Process.", Welding Journal, Research Supplement, March 1990, pp 83-s to 97-s.
71. Saberski, Rolf H., et al, "Fluid Flow, A First Course in Fluid Mechanics.", 3rd Edition, Macmillan Publishing Co., 1989.
72. Sadeh, W. Z., Sture, S., and Miller, R. J., "Engineering, Construction, and Operations in Space III, Space '92, Proceedings of the Third International Conference, Denver, Colorado, 31 May - 4 June 1992.", Vol. I and II, American Society of Civil Engineers, 1992.
73. Sanders, M. S., and McCormick, E. J., "Human Factors in Engineering and Design.", 6th Edition, McGraw-Hill, Inc., 1987.
74. Sauerwein, T., "The Telerobot Workstation Testbed for the Shuttle Aft Flight Deck: A Project Plan for Integrating Human Factors into System Design.", from: "Proceedings of the Conference on Space Telerobotics.", held at JPL on 31 January, 1989, Vol. 5, NASA CR-186858, N90-29887, pp. 121, 1989.



75. Savely, R. T., "Fourth Annual Workshop on Space Operations, Applications, and Research (SOAR '90).", Proceedings of a workshop held in Albuquerque, New Mexico from 26-28 June, 1990, NASA Conference Publication 3103, Vols. I and II, NASA Office of Management, STI Division, 1991.
76. Sheridan, T. B., "Telerobotics, Automation, and Human Supervisory Control.", Final draft for book to be released, MIT Press Publication, February 1992.
77. Srivastava, S., et al, "Automated Assembly in Space.", from: NASA-HBCU Space Science and Engineering Research Forum Proceedings, NASA CR-188650, pp. 313, N91-28106, 1989.
78. Stonecipher, K., "Industrial Robotics: Machine Vision, and Artificial Intelligence.", Howard W. Sams & Company, 1989.
79. Streiner, G., and Norman, D., "PDQ Statistics.", B. C. Decker, Inc., 1986.
80. Tate, A., "Coordinating the Activities of a Planner and an Execution Agent.", from: "Proceedings of the Conference on Space Telerobotics.", held at JPL on 31 January, 1989, Vol. 1, NASA CR-186858, N90-29035, pp. 385, 1989.
81. Taylor, Edith C., and Michael Ross. "A Comparison of the Shuttle Remote Manipulator System and the Space Station Freedom Mobile Servicing Center.", AIAA Paper N90-29910.
82. Tucci, L. and Lawler, A., "Space News.", March 29 - April 4, 1993, Vol. 4, No. 13, pp. 1-3.
83. Vargo, R., "On-Orbit Assembly and Refurbishment of Lunar Transfer Vehicles.", Engineering, Construction, and Operations in Space III, Space '92, Proceedings of the Third International Conference, Denver, Colorado, 31 May - 4 June 1992., Vol. I, pp 885, American Society of Civil Engineers, 1992.
84. Waller, D. N., "Developments in Automated and Robotic Welding.", Second International Conference, London, England, 17-19 November 1987, The Welding Institute, Cambridge Great Britain, 1988.
85. Wessels, W. R., et al, "On-Orbit Chipless Cutting and Tube Welding in Space Station Freedom.", Engineering, Construction, and Operations in Space III, Space '92, Proceedings of the Third International Conference, Denver, Colorado, 31 May - 4 June 1992. Vol., pp 815, American Society of Civil



Engineers, 1992.

86. Weston, J., "Exploiting Robots in Arc Welded Fabrication.", The Welding Institute, 1989.

87. Yoerger, D. R., "Supervisory Control of Underwater Telemanipulators: Design and Experiment.", MIT PhD Thesis, Mechanical Engineering Department, 1983.















GAYLORD S





3 2768 00036271 9