



Calhoun: The NPS Institutional Archive
DSpace Repository

Theses and Dissertations

1. Thesis and Dissertation Collection, all items

2006-09

Impact of radio frequency identification (RFID) on the Marine Corps' supply process

Chestnut, Melissa D.

Monterey California. Naval Postgraduate School

<https://hdl.handle.net/10945/2548>

Downloaded from NPS Archive: Calhoun



Calhoun is the Naval Postgraduate School's public access digital repository for research materials and institutional publications created by the NPS community. Calhoun is named for Professor of Mathematics Guy K. Calhoun, NPS's first appointed -- and published -- scholarly author.

Dudley Knox Library / Naval Postgraduate School
411 Dyer Road / 1 University Circle
Monterey, California USA 93943

<http://www.nps.edu/library>



**NAVAL
POSTGRADUATE
SCHOOL**

MONTEREY, CALIFORNIA

THESIS

**IMPACT OF RADIO FREQUENCY IDENTIFICATION
(RFID) ON THE MARINE CORPS' SUPPLY PROCESS**

by

Melissa D. Chestnut

September 2006

Thesis Advisor:
Second Reader:

Kenneth Doerr
Glen Cook

Approved for public release; distribution is unlimited

THIS PAGE INTENTIONALLY LEFT BLANK

REPORT DOCUMENTATION PAGE			Form Approved OMB No. 0704-0188	
Public reporting burden for this collection of information is estimated to average 1 hour per response, including the time for reviewing instruction, searching existing data sources, gathering and maintaining the data needed, and completing and reviewing the collection of information. Send comments regarding this burden estimate or any other aspect of this collection of information, including suggestions for reducing this burden, to Washington headquarters Services, Directorate for Information Operations and Reports, 1215 Jefferson Davis Highway, Suite 1204, Arlington, VA 22202-4302, and to the Office of Management and Budget, Paperwork Reduction Project (0704-0188) Washington DC 20503.				
1. AGENCY USE ONLY (Leave blank)		2. REPORT DATE September 2006	3. REPORT TYPE AND DATES COVERED Master's Thesis	
4. TITLE AND SUBTITLE: Impact of Radio Frequency Identification (RFID) on the Marine Corps' Supply Process			5. FUNDING NUMBERS	
6. AUTHOR(S) Melissa D Chestnut				
7. PERFORMING ORGANIZATION NAME(S) AND ADDRESS(ES) Naval Postgraduate School Monterey, CA 93943-5000			8. PERFORMING ORGANIZATION REPORT NUMBER	
9. SPONSORING /MONITORING AGENCY NAME(S) AND ADDRESS(ES) N/A			10. SPONSORING/MONITORING AGENCY REPORT NUMBER	
11. SUPPLEMENTARY NOTES The views expressed in this thesis are those of the author and do not reflect the official policy or position of the Department of Defense or the U.S. Government.				
12a. DISTRIBUTION / AVAILABILITY STATEMENT Approved for public release; distribution is unlimited			12b. DISTRIBUTION CODE	
13. ABSTRACT (maximum 200 words) The purpose of this research is to determine the impacts of utilizing radio frequency identification (RFID) technology in order to implement in-transit visibility (ITV) into the Marine Corps' Supply Process. I interviewed experts and users of the LTMITV/W2W at the Supply Management Unit (SMU), 1 st Combat Logistics Regiment, 1 st Marine Logistics Group on the operational implementation of the system as well as benefits and opportunities for improvement. With the information I recovered and data I collected, I was able to create a small simulation of the supply process. I used the simulation to create various scenarios that have been encountered in the past including possible negative impacts of the lack of ITV at certain portions of the supply process. I made recommendations on how to improve the current supply process as well as recommendations for future research.				
14. SUBJECT TERMS In-transit Visibility, RFID, LTMITV, Supply Process, Simulation			15. NUMBER OF PAGES 106	
			16. PRICE CODE	
17. SECURITY CLASSIFICATION OF REPORT Unclassified	18. SECURITY CLASSIFICATION OF THIS PAGE Unclassified	19. SECURITY CLASSIFICATION OF ABSTRACT Unclassified	20. LIMITATION OF ABSTRACT UL	

THIS PAGE INTENTIONALLY LEFT BLANK

Approved for public release; distribution is unlimited

**IMPACT OF RADIO FREQUENCY IDENTIFICATION (RFID) ON THE
MARINE CORPS' SUPPLY PROCESS**

Melissa D. Chestnut
Captain, United States Marine Corps
B.S., Clark Atlanta University, 1998

Submitted in partial fulfillment of the
requirements for the degree of

MASTER OF SCIENCE IN INFORMATION TECHNOLOGY MANAGEMENT

from the

**NAVAL POSTGRADUATE SCHOOL
September 2006**

Author: Melissa D. Chestnut

Approved by: Kenneth Doerr
Thesis Advisor

Glen Cook
Second Reader

Dan Boger
Chairman, Department of Information Sciences

THIS PAGE INTENTIONALLY LEFT BLANK

ABSTRACT

The purpose of this research is to determine the impacts of utilizing radio frequency identification (RFID) technology in order to implement in-transit visibility (ITV) into the Marine Corps' Supply Process. I interviewed experts and users of the LTMITV/W2W at the Supply Management Unit (SMU), 1st Combat Logistics Regiment, 1st Marine Logistics Group on the operational implementation of the system as well as benefits and opportunities for improvement. With the information I recovered and data I collected, I was able to create a small simulation of the supply process. I used the simulation to create various scenarios that have been encountered in the past including possible negative impacts of the lack of ITV at certain portions of the supply process. I made recommendations on how to improve the current supply process as well as recommendations for future research.

THIS PAGE INTENTIONALLY LEFT BLANK

TABLE OF CONTENTS

I.	INTRODUCTION	1
A.	OVERVIEW	1
B.	STATEMENT OF PROBLEM	2
C.	ORGANIZATION OF THESIS	4
II.	BACKGROUND	7
A.	RFID TECHNOLOGY	7
1.	Current Objectives of RFID Technology in the DoD	9
2.	Benefits of RFID Technology	10
3.	Limitations of RFID Technology	11
B.	REASON FOR LTMITV/W2W IN THE MARINE CORPS	12
III.	OPERATIONAL EMPLOYMENT FOR LTMITV/W2W	17
A.	CURRENT ARCHITECTURE/EMPLOYMENT FOR LTMITV/W2W ...	17
1.	Current Architecture	18
2.	Current Employment of LTMITV	21
3.	Benefits of ITV	23
B.	MARINE CORPS SUPPLY PROCESS	24
IV.	ANALYSIS	27
A.	ASSUMPTIONS	27
B.	SIMULATON MODEL DESCRIPTION	30
C.	METHODOLOY	34
1.	Data Collection	35
D.	VARIABLES AND PARAMETERS	39
1.	Total Demands Distribution	40
2.	Courier and Process Delay Distributions	41
3.	Fill Rate Probability	42
4.	Backorder Priority Probability	44
5.	'SMU OnHand' Sub-Model Distributions	45
6.	'Backorder by SMU' Sub-Model Distributions ...	47
7.	'Backorder by SOS' Distributions	49
E.	SCENARIOS	52
1.	Base Case (As-Was): The Marine Corps' Supply Process Prior to ITV	53
2.	Real-Time: Hypothetical Improvement Using a Real-Time Order Processing System Vice a Batch Order Processing System	56
3.	As-Is: The Current Marine Corps Supply Process	57

4.	To-Be: The Marine Corps Supply Process Using a Real-time Order Processing System Vice a Batch Order Processing System	58
V.	RESULTS	69
A.	SIMULATION RESULTS	69
1.	Base Case (As-Was): The Marine Corps' Supply Process Prior to ITV	69
2.	Real-Time: Hypothetical Improvement Using a Real-Time Order Processing System Vice a Batch Order Processing System	71
3.	As-Is: The Current Marine Corps Supply Process with ITV	72
4.	To-Be: The Marine Corps Supply Process Using a Real-time Order Processing System Vice a Batch Ordering Processing System	74
VI.	CONCLUSION	77
A.	RECOMMENDATIONS	77
B.	FUTURE RESEARCH	78
APPENDIX A.	UNIT PERFORMANCE REPORT	81
APPENDIX B.	DAILY TRANSACTION LISTING	83
	LIST OF REFERENCES	85
	INITIAL DISTRIBUTION LIST	87

LIST OF FIGURES

Figure 1. Current Marine Corps ITV Architecture (From [9] p.32)	20
Figure 2. System Interaction (From [10])	21
Figure 3. Total demands distribution with normal expression: $NORM[825,508]$ (From [16])	41
Figure 4. Shipping Times for Low Priority Backorders with expression: $[[120 + EXPO(221)]]$ (From [16])	48
Figure 5. Shipping Times for High Priority Backorders with expression: $[120 + 6.58e+003 * BETA(0.674, 2.21)]$ (From [16])	50
Figure 6. Simulation	60
Figure 7. Sub-Model: SMU Onhand	61
Figure 8. Sub-Model: Backorder by SMU - Not on Hand & Low Priority Backorder	62
Figure 9. Sub-Model: Backorder by SOS - Not on Hand & High Priority Backorder	63
Figure 10. Modified 'SMU OnHand' sub-model for As-Was and Real-Time Scenarios	64
Figure 11. Modified 'Backorder by SMU' sub-model for As-Was and Real-Time scenarios	65
Figure 12. Modified 'Backorder by SOS' sub-model for As-Was and Real-Time scenarios	66
Figure 13. Real-Time and To-Be Modified Supply Process - No Batch Ordering	67

THIS PAGE INTENTIONALLY LEFT BLANK

LIST OF TABLES

Table 1.	Summary of Distributions	52
Table 2.	Base Case (As-Was) Simulation Results	70
Table 3.	Real-Time: As-Was Using Real-Time Vice Batch Ordering	71
Table 4.	As-Is: The Current Marine Corps Supply Process with ITV	73
Table 5.	To-Be: The Marine Corps Supply Process Using a Real-time Order Processing System Vice a Batch Order Processing System	75

--

THIS PAGE INTENTIONALLY LEFT BLANK

LIST OF ABBREVIATIONS AND ACRONYMS

AAC	Activity Address Code
ATLASS I	Asset Tracking for Logistics and Supply System
BCS3	Battle Command Sustainment Support System
DIC	Document Identifier Code
DLA	Defense Logistics Agency
DoD	Department of Defense
F/AD	Force Activity Designator
FOB	Forward Operating Bases
FSSG	Force Service Support Group
GAO	General Accounting Office
I&L	Installation and Logistics
ITV	In-Transit Visibility
LTM	Last Tactical Mile
LTMITV	Last Tactical Mile In-Transit Visibility
MCAGCC	Marine Corps Air Ground Combat Center
MCAS	Marine Corps Air Station
MEF	Marine Expeditionary Force
MEF	Marine Expeditionary Force
MIMMS	Marine Corps Integrated Management System
MLG	Marine Logistics Group
MRO	Material Release Order
NSN	National Stock Number
OIC	Officer-in-Charge
OIF	Operation Iraqi Freedom
PM-AIT	Program Manager-Automated Information Technology
RFID	Radio Frequency Identification
RO	Requisitioning Objective
RUC	Reporting Unit Code
SASSY	Supported Activities Supply System
SOS	Source of Supply
SMU	Supply Management Unit
TCN	Transportation Control Number
TMO	Traffic Management Office
W2W	Warehouse to Warfighter

THIS PAGE INTENTIONALLY LEFT BLANK

ACKNOWLEDGMENTS

I would like to first thank Dr. Kenneth Doerr for guiding me through this process. Your insight, knowledge and experience was crucial to my success. I would also like to thank the Marines at the SMU for assisting me in my data collection. Without your efforts I literally could not have completed my thesis.

THIS PAGE INTENTIONALLY LEFT BLANK

I. INTRODUCTION

A. OVERVIEW

As a Company Commander in a Combat Service Support (CSS) battalion during Operation Iraqi Freedom I (OIF-I), I was bombarded with questions on a regular basis from supported units as to the location of their repair parts. Unfortunately once the items were in theater, trying to locate parts ordered was nearly impossible. This was an ongoing problem for all CSS units during OIF-I and what had become the norm was now unacceptable. A General Accounting Office (GAO) report (GAO-04-305R) dated 18 December 2003 acknowledged the military successes during combat operations as well as identified substantial logistics support issues in theater. The GAO report identified the following issues:

- Inadequate asset visibility based on the backlog of hundreds of containers.
- A \$1.2 billion gap between the amount of material shipped to the theater of operations, and the amount of material acknowledged upon receipt of shipment.
- Potential loss of millions of dollars in late fees on leased or replaced containers for the DOD, as a result of distribution backlogs or losses.
- Compromised readiness issues because of a lack of parts inventory, or parts that could not be located due to inadequate asset visibility.
- Duplication of requisitions, again due to the lack of asset visibility of parts previously ordered by the support units. [1]

All of these issues are of great importance but this thesis will key-in on the inadequate asset visibility issue. The GAO report also stated that "although U.S. Central Command issued a policy requiring, whenever feasible, the use of radio frequency identification (RFID) tags to track assets shipped to and within the theater, these tags were not used in a uniform and consistent manner." [1] In a nutshell once the assets were in theater the asset visibility stopped at the port. The Marine Corps had never traveled so far inland during combat operations so OIF-I was completely new territory. The strain on the logistics trains reinforced the need for a technology to enable commanders to have asset visibility up and down the supply chain. RFID technology is currently the answer to this problem. The Marines of I Marine Expeditionary Force (MEF) took on the responsibility of providing in-transit visibility (ITV) down to the last tactical mile for supply parts which led to the development of a software program that was capable of providing some form of asset visibility to the using unit as the supply part traveled from the warehouse to the warfighter. The logistics modernization initiative is referred to as the Last Tactical Mile In-Transit Visibility (LTMITV) or Warehouse to Warfighter. In partial support of the LTMITV initiative, this thesis will attempt to address some of the impacts RFID technology has on the supply process, and potential limitations of the current system that might impact the efficacy of RFID technology in the Marine Corps' current supply process.

B. STATEMENT OF PROBLEM

It is always easier to provide logistics support in a static environment than in a dynamic one. We need to have

accurate, complete and refined business processes in a static environment before even considering implementing the process in a dynamic one. That is why the author will examine the step-by-step process of what happens to a requisition once it is ordered by a unit and give approximate delays and shipping times based on if the item is on hand or is placed on backorder. Testing ITV in a static or garrison environment is paramount in correcting the problem of distribution and asset location during a dynamic environment. 1st Marine Logistics Group (MLG), 1st Supply Battalion, Supply Management Unit (SMU¹) in Camp Pendleton, CA is currently conducting real world tests from Camp Pendleton to using units on the west coast. Their goal is to employ an asset tracking/in-transit visibility system that nearly mimics the system and processes used in Iraq. Not all parts of the supply process allow in-transit visibility for the end user. Are there certain locations during the supply process where in-transit visibility is needed? If so, how will this ITV benefit the user? Currently there are two separate methods for tracking parts that have been requisitioned; one is nodal, visibility of a part can only be determined based on the last known location, and the other is the use of the global positioning system (GPS), visibility of a part is given by a current grid coordinate.

¹ SMU maintains, tracks, and issues repair parts to using units throughout the Marine Corps. There is a SMU for each MEF.

Throughout this thesis the following questions will be answered:

1. What is the typical supply flow process for a requisition in the MEF supply chain?
 - a. How long will it take a unit to receive a part if the SMU has the item on hand?
 - b. How long will it take a unit to receive a part if the SMU does not have on hand?
 - c. What is the percentage of orders that are immediately filled by the SMU?
 - d. What role does priority of the requisition play in the supply process?
2. How does ITV improve the MEF supply chain?
3. At what point in the MEF supply chain does ITV begin for the end user?
4. At what a point in the MEF supply chain does ITV not exists?
5. How is the current LTMITV/W2W system configured?
6. How is the end user able to track their parts in the current LTMITV?

C. ORGANIZATION OF THESIS

This thesis will start with a description of RFID technology, how it works, along with some of its advantages and disadvantages. Then it will examine the Marine Corps' rationale for the use of the LTMITV/W2W system, the current architecture of the system and how it is employed.

In order to determine the locations where in-transit visibility (ITV) is most needed as well as estimate

shipping times for requisitions, a simulation will be developed to model the current supply process. This model will be described in detail and used to analyze the impacts of RFID-enabled ITV on the Marine Corps' supply process from the perspective of the using unit. The benefits of implementing ITV into the supply process will be substantiated by using a base case scenario of what life was without ITV and how life has improved since then.

Finally, based on the results of the simulation, recommendations will be made as to how to improve the current supply process and or the implementation of RFID technology with the Marine Corps supply process, and directions for future research on this topic will be recommended.

THIS PAGE INTENTIONALLY LEFT BLANK

II. BACKGROUND

A. RFID TECHNOLOGY

Radio Frequency Identification (RFID) is an automatic identification method that uses radio waves to identify physical objects. It is a technology tool that holds the promise of replacing existing identification technologies like the bar code and providing improved asset visibility for the DoD. Although the benefits of RFID technology are substantial, implementing the technology, even at a minimal compliance level, can be an overwhelming task. [2] A logistics command that has been tasked with using RFID technology must first understand the components of a RFID system and how all these components interact. The mandatory components of the RFID system are the tag, the reader, the reader antenna, the controller, and the communication infrastructure. The optional components are the sensor, actuator, and annunciator, and the host or software system. [3]

The RFID tag is a device that stores and transmits data to a reader using radio waves. RFID tags fall into three broad categories - passive, active, and semi-passive (or semi-active). Passive tags require no internal power source; instead it uses the power from the incoming signal to energize itself and then transmits the stored data to the reader. Active tags require a power source to transmit data to a reader. Semi-passive tags use an internal power source to monitor environmental conditions, but require radio frequency energy transferred from the reader similar

to passive tags to power a tag response. The RFID tags can be attached to a product or integrated into the product. [3]

The RFID reader, or interrogator, is a device that can read from and write data to compatible RFID tags. The reader communicates with the RFID tag via radio waves and passes the information in digital form to a computer system. There are four types of readers: serial, network, stationary, and handheld. Each has certain advantages and disadvantages. The type of reader an organization would use depends on the reliability of the communication length, their dependence on the length of cable to connect the reader to a computer, and the amount of money the organization is willing to spend. A reader antenna is a separate device that is physically attached to a reader and is used by the reader to communicate to a tag. [3]

The other two mandatory components, the controller and the communications infrastructure, possess features that allow an organization to employ RFID technology successfully. The controller allows an external entity, either human or a computer program, to communicate with and control a reader's functions with the annunciators and actuators associated with this reader. While the communications infrastructure provides connectivity and enables security and systems management functionalities to different components of an RFID system. The optional components; sensor, annunciator, and actuator and host and software systems; are needed for external input and output of the system. Even though these components are optional, an RFID system is close to useless without them. [3]

All of these components of the RFID system come together to make RFID technology work. First the tag is attached to the object that needs to be identified. Unique identification data about this tagged object is stored onto the tag. When the tagged item is introduced in front of a RFID interrogator, the tag transmits the data to the interrogator. The interrogator will then read and forward the data over a reliable communication channel to a software application running on a computer. The software application can then use the unique data to identify the object presented to the reader. From here depending on the type of software a variety of actions can be performed such as updating the location of the information, sending an alert to the warehouse personnel, or ignoring it. [3]

1. Current Objectives of RFID Technology in the DoD

Since the early 1990's the DoD has been using RFID technology to label shipping containers moving throughout the DoD supply chain. [2] However both active and passive RFID technologies have been in commercial business applications from the late 1980s through today. The use of passive RFID technologies is currently emerging in the DoD following the finalization of the DoD RFID Policy in June 2004 that required suppliers to put passive RFID tags on the lowest possible piece part/case/pallet packaging by January 2005. [4] Active tags have been a staple in DoD large scale packaging since the early 1990's. The use of the technology has addressed a major challenge that has been noted at every node within the DoD Supply chain--lack of visibility of item data. Steps have been taken by the DoD through each military service to incorporate RFID in

their supply distribution chain in order to provide ITV necessary for units on the ground.

It has also been proposed to use RFID technology for point of sale (POS) store checkout to replace the cashier with an automatic system which needs no barcode scanning. However this is not likely to be possible without a significant reduction in the cost of current tags and changes in the operational process around POS. There is some research taking place, however, this is some years from being achieved.

The DoD is most interested in using RFID technology to:

- 1) provide near real-time in-transit visibility for all classes of supplies and material,
- 2) provide "in the box" content detail for all classes of supplies and material,
- 3) provide quality, non-intrusive identification and data collection that enable enhanced inventory management, and
- 4) provide enhanced item level visibility. [5]

2. Benefits of RFID Technology

There are a number of benefits to RFID technology. One benefit is that an RFID tag can be read without any physical contact between the tag and the reader. An RFID tag can have a read range as small as a few inches to as large as more than 100 feet, although the reading distance can also be considered a limitation. An RFID tag can store from a few bytes of identification data to a large database of item and environmental history. RFID tags can sustain rough operational environmental conditions to a fair

extent. The most important benefit is that RFID is 100% accurate, as long as the data is correctly input. [3]

Other benefits of RFID includes offering strategic advantages to businesses by being able to track inventory in the supply chain more efficiently, providing real-time in-transit visibility, and monitoring general enterprise assets. [2] These business advantages lead to even more advantages such as reducing and possibly eliminating human intervention in some business processes, having higher throughput supply chains by allowing more items to be counted simultaneously, providing real-time information flow because as soon as an item changes its condition or state, the information can be updated across the supply chain and lastly by providing the ability to track individual items with serialized data, meaning each item has its own unique identifier or serial number. [2]

The benefits of central importance in this thesis are the identification data the RFID tag can store which enables the user to accurately identify the items that are associated with a tag, the integration of RFID technology with a communications infrastructure to provide in-transit visibility, and the strategic business advantage of RFID technology's ability to monitor general enterprise assets.

3. Limitations of RFID Technology

Although there are substantial advantages to RFID technology it is not the answer to all of our supply distribution problems. RFID performs poorly with any objects that are not transparent or opaque such as metal and any objects that are absorbent, such as a liquid. RFID solutions are also impacted by certain environmental

factors. Due to its poor performance with RF-absorbent objects, when in an operating environment where there is high human traffic, if a person is between a tag and a reader, there is a good possibility that the reader cannot read the tag before the person moves away. This is primarily due to the fact that the human body contains a large amount of water. [3] RFID tags are also susceptible to electromagnetic interference from computing equipment, lighting fixtures, etc. [6] While technological solutions are being sought to these limitations, at least in the short term, they remain an obstacle to the universal application of RFID.

One main disadvantage of RFID technology and why many businesses are slow to implement it is the cost of RFID, relative to the incremental benefit of RFID over a bar code system. Passive tags are currently discarded after the item is sold. Therefore, the replacement cost of them can get quite unaffordable. "Currently the cost of passive RFID tags is approximately 40 cents, and if the tags are active, the cost per tag might increase to a few dollars." [7] Even though the cost of RFID tags should continue to decline due to economies of scale, the cost of the tags only represents a very small fraction of the overall cost to implement an RFID system.

B. REASON FOR LTMITV/W2W IN THE MARINE CORPS

The fog and friction of war is not only a constant concern to the art and science of war but to the art and science of logistics as well. In the opinion of the author, lessons from Operations Desert Shield and Desert Storm were not fully learned, and the logistical problems faced during Operation Enduring Freedom and Operation Iraqi

Freedom (OEF/OIF) were similar to those faced in the earlier conflicts. One primary lesson that should have been learned from Operations Desert Shield and Desert Storm in relation to logistics was the inadequate accountability over material. After a GAO report was published to address these accountability concerns, the DoD stated "it has pledged a substantial amount of financial and managerial resources, which it believes will improve handling, shipping, and tracking in material in future contingencies." [8]

Shortly after this GAO report was released the RFID initiative began and the DoD began using RFID technology to keep better track of necessary supplies to make sure the supplies reach the troops wherever they are needed. OIF posed the same logistical problems as in Operations Desert Storm and Desert Shield, except on a smaller scale. There was no need to stockpile 30 - 60 days of supplies because units were constantly on the move and they were only able to carry 3-7 days of supplies. The DoD had solved the problem of tracking supplies from the US to a foreign port but once the supplies left the port their location could not be tracked in-transit. There was now a need to track the supplies down to the unit who requested it or down to the last tactical mile. The location of the supplies needed to be known while they were in-transit from the warehouse who issued the gear to the warfighter who signed for the gear. [9] Thus came a need, and the creation of the Marine Corp's Logistics Modernization movement, with the goal of providing excellence in logistics to support excellence in warfighting.

In a report submitted by the Commanding Officer, Combat Service Support Group 15, to the DoD for consideration to receive the 2004 Supply Chain Operational Excellence Award, Brigadier General Edward Usher, Commanding General, 1st Force Service Support Group (FSSG), I Marine Expeditionary Force (MEF), OIF was quoted as saying:

Our biggest shortfall during OIF-I was the lack of In-Transit Visibility information to incorporate in to our command and control efforts.... The lack of asset visibility on unit stocks and in-transit visibility on ordered items made it difficult to identify actual shortages, to locate needed items, within stocks for reallocation, and to direct and track the movement of ordered items to requesting units. This lack of visibility resulted in delays, shortages, and at times an inability to expedite critical parts. [9]

This delinquency in asset visibility as noted by the 1st FSSG Commanding General and the mandate by the DoD that RFID technology will be used to track all cargo movement prompted the supply chain experts of the Supply Management Unit (SMU) of 1st Supply Battalion, 1st FSSG (now 1st Marine Logistics Group (MLG)), 1st MEF to aggressively seek available commercial RFID technology software and hardware currently used by the Army. Although the Army's current use of the technology met the DoD's mandate, their use fell short of the tracking of requirements that were envisioned by the SMU's supply chain experts. The SMU supply chain experts end state was that the Marine Corps would have the ability to track all content level shipments down to the "The Last Tactical Mile (LTM)". Over time the supply chain experts knew that nodal visibility would not be enough and

that eventually the warfighter would need near-real-time visibility: the answer would be the Warehouse to Warfighter (W2W) portal. The W2W portal does not rely on nodal interrogators and gives the unit visibility and tracking for what was dropped at a location, who received it and the grid at which it was dropped. Overall a complete ITV system would be able to do the following:

- Reduce excessive requisitions
- Improve the Commander's ability to track critical items
- Optimize asset posture and accountability
- Allow for the recoverability of misdirected shipments [9]

The SMU conducted an analytical review following OIF-I which determined that three aspects of the supply chain required immediate process reform; asset visibility (on hand and in-transit), asset availability, and order management. [9] This thesis is primarily concerned with asset visibility and therefore the majority of the work will focus on ITV. Currently Headquarters Marine Corps, Installation and Logistics (I&L) Command is in the process of conducting a complete Logistics Modernization that would ultimately replace current legacy supply and maintenance systems; however, that operational architecture is still a few years out. In the interim the SMU decided to employ current commercial capabilities to help resolve ITV issues, improve order management, and increase availability of critical repair parts. [9]

THIS PAGE INTENTIONALLY LEFT BLANK

III. OPERATIONAL EMPLOYMENT FOR LTMITV/W2W

A. CURRENT ARCHITECTURE/EMPLOYMENT FOR LTMITV/W2W

Out of the three aspects of the supply chain (asset visibility, asset availability, and order management) that required immediate process reform, asset visibility or ITV was considered the most critical factor behind the less than adequate supply support capability during OIF-I. [9] In August 2003 efforts began to create a more reliable and extensive ITV, by using RFID tags and satellite tracking devices. At that time SMU published a campaign plan that stated by August of 2004, the following end state was desired:

All assets managed by the SMU are visible to the supply chain in one location. Items moving in-transit through the supply chain will be visible down to [the] document number detail and the physical location of that material as it moves from node to node until final delivery to the supported unit. [9]

Due to the pressure to have a system in place by OIF-II the SMU decided to use existing infrastructures of the Army and the Defense Logistics Agency (DLA). These two were already using SAVI[®] RFID tags and had interrogators placed at key logistics and distribution nodes. The SMU would then expand the infrastructure in place, to include tactical Forward Operating Bases (FOB) and Logistic Support Areas with I MEF Area of Operations. [9] A Marine Corps specific system was developed entitled Last Tactical Mile In-Transit Visibility (LTMITV). This system only provides "nodal" visibility. Soon the W2W portal was created which

provides longitude and latitude coordinates for a specific RFID tag. The W2W portal is intended to provide a near-real-time in-transit visibility. Unfortunately the W2W hardware components are not always 100% effective therefore instead of replacing the LTMITV system the W2W has enhanced its capability. In order to allow both system to work together the W2W data feeds into the LTMITV system, transmitting the GPS data to the website. [10]

1. Current Architecture

As data is written to an RFID tag, that information is sent to an appropriate ITV server managed by the Program Manager-Automated Information Technology (PM-AIT). PM-AIT falls under the US Army as the executive service. As the active RFID tags pass interrogators throughout the distribution chain, the tag number (unique identifier) is collected and transmitted to the appropriate ITV server. This allows units to query the ITV servers and gain nodal visibility of the last known distribution node in which the USMC sustainment cargo has passed. Units are able to query the ITV server using document numbers, National Stock Numbers (NSN), Transportation Control Numbers (TCN), and RFID tag numbers. [9]

Currently the Marine Corps' ITV system is the Automated Manifesting System - Tactical (AMS-TAC). This system is designed to combine a user-friendly software package and a state-of-the art hardware system into an efficient, cost effective and compact shipping manifest database management system. [11] All of the pertinent data for the shipping container to include document numbers, quantity, Activity Address Code (AAC) etc. is added to the

RFID tag using the AMS-TAC. AMS-TAC then sends the manifest data to the US Army's ITV web site, 'RF-ITV Tracking Portal.' As RFID tags pass interrogators the interrogators transmit the updated RFID tag location to the Army's ITV web site. SMU then extracts the data from the ITV server to create a courier² with AS1 (shipping) transactions in the Supported Activities Supply System (SASSY),³ the primary retail accounting system for the Marine Corps. The AS1 transactions will identify the key distribution nodes in the distribution pipelines. The AS1's signify certain Combat Service Support Areas/Elements/Battalions/Groups that are apart of the distribution chain and therefore have an interrogator posted at their location. The courier is then processed and posts on the units' Due in and Status File (DASF) where the using unit can track their assets.

At the same time that the RFID tag data is loaded onto the AMS-TAC it is also loaded into the W2W/LTM kits. These kits were designed to give the warfighter and maintainers near-real-time visibility of supply status leaving the SMU, down to the individual document level. [9] The data is captured at each delivery point and posted to an independent File Transfer Protocol (FTP) server. While the tag is in-transit, GPS coordinate updates are sent to the Marine Corps LTMITV site, developed by Sytex Corporation⁴. The system also provides the user as to where the supplies were delivered as well as who received them. If the gear is

² A collection of transactions created by a using unit that includes demands as well as other pertinent transactions.

³ SASSY provides retail supply accounting functions such as stock replenishment, requirement determination, receipts, inventory, stock control and asset visibility.

⁴ Sytex, Inc. has since been purchased by Lockheed Martin.

delivered to the unit, an AS2 (shipping to unit) transaction is created. If the gear is dropped off at a camp along the way an AS1 is created. Once again a courier is processed and posts to the DASF where the using unit can check the status. The Army's ITV server and the Marine Corps' LTMITV server feed into the Battle Command Sustainment Support System (BCS3). This system allows you to view multiple assets such as transporters, individual document numbers, units and interrogators. See Figure 1 for an upper level view of the architecture. [9] Figure 2 is a simple view of how all the systems interact. [10]

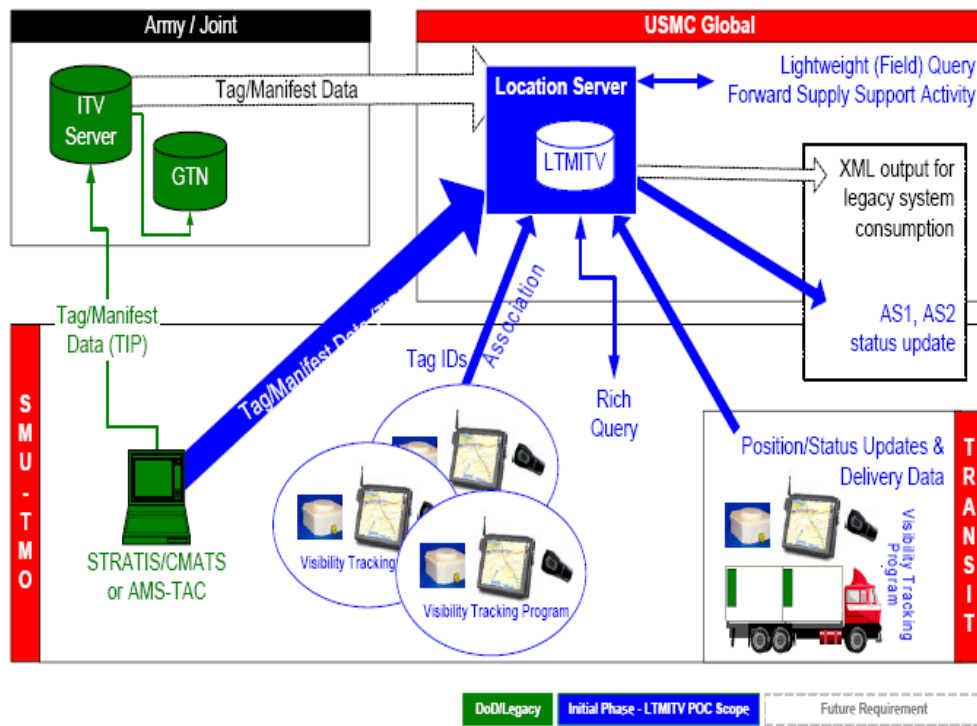

Figure 1. Current Marine Corps ITV Architecture (From [9] p.32)

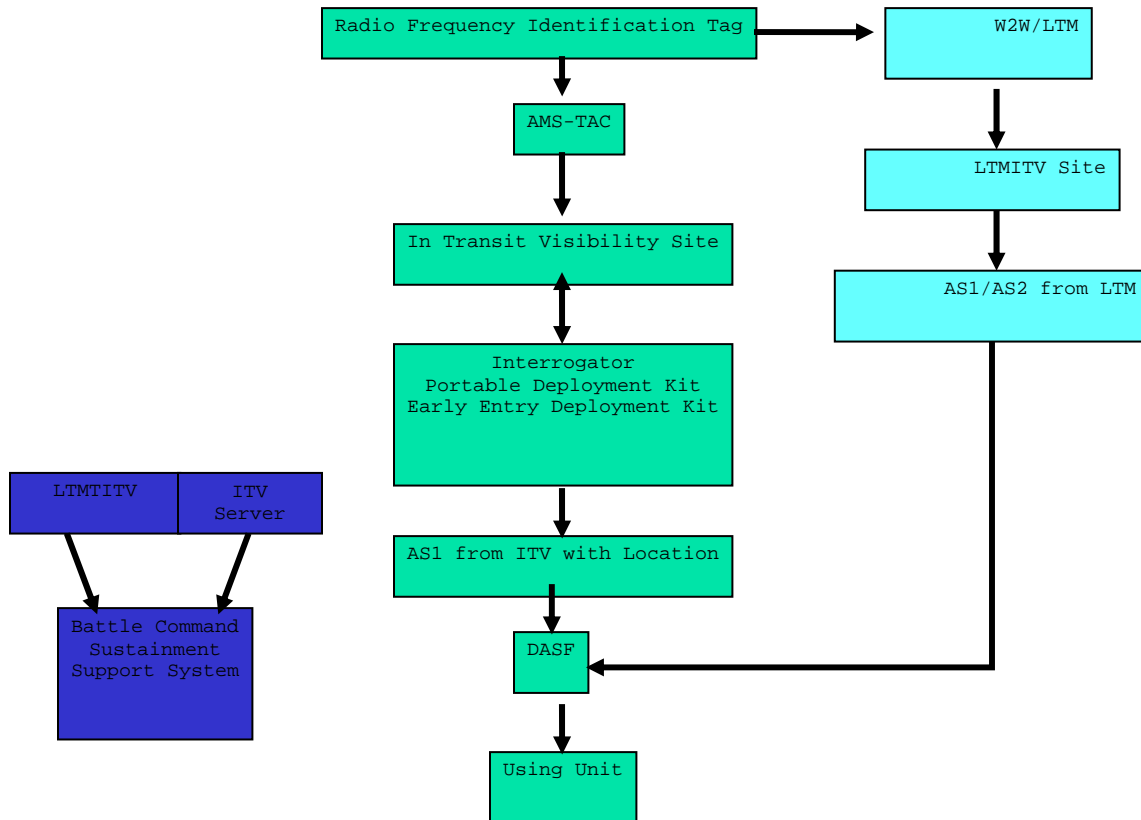

Figure 2. System Interaction (From [10])

2. Current Employment of LTMITV

Currently RFID technology is in daily use in Garrison as well as in a theater of operation, specifically Iraq. In order to suit a tactical environment Portable Deployment Kits⁵ (PDK) are being used. A PDK is a self-contained carrying case that delivers a fully mobile solution. The kits address the Marine Corps' need to provide visibility where a RFID fixed reader infrastructure does not exist. In garrison, specifically from the SMU at 1st Supply Battalion in Camp Pendleton, CA all forms of the ITV system are in place to include the W2W portal that feeds into the Marine Corps' LTMITV site, AMS-TAC which feed into the

⁵ Savi Technology, Inc. developed this RFID mobile solution to directly support the war fighter deployed in the Area of Operations.

Army's ITV site, as well as PDK's for units that are conducting field training exercises. Assets are shipped from the SMU on a regular basis in support of units on the west coast as well as units overseas.

The SMU has targeted critical areas within the area of operation (whether being Iraq to Kuwait or Camp Pendleton to Yuma) to serve as visibility points for supplies flowing throughout the distribution chain. To simplify data collection and validation the author selected Camp Pendleton as a test site and the main analysis will focus on the implementation of ITV in Camp Pendleton. While certainly there are field obstacles in an area of operation such as Iraq which cannot be examined by looking at Pendleton, neither data nor personnel were available to support an analysis of operations in Iraq. Moreover, Pendleton operations can be seen as a 'base case', in the sense that benefits may be obtained more easily, at a lower cost than in deployed operations. In other words, if the system does not make sense at Pendleton, it is unlikely to be viable in Iraq.

There are several interrogators located in Camp Pendleton to include: the end of Warehouse road, the Traffic Management Office⁶ (TMO), the front gate (Goes into Interstate 5), Fallbrook gate, and Las Pulgas. Once off base, interrogators are located at the entry points of the Marine Corps Air Station (MCAS) Miramar, MCAS Yuma, and Marine Corps Air Ground Combat Center (MCAGCC) Twenty-nine (29) Palms, CA. The interrogators are used in conjunction

⁶ TMO is equivalent to the civilian sector's UPS. They ship all assets to using units on tractor trailers on a daily basis, except for holidays and weekends.

with the W2W GPS enabled kits, if there is no GPS data available the unit will at least have the last known nodal location of their assets. [10]

A new section at the SMU entitled the Process Reform Center was created in order to assist the SMU in reforming the three critical aspects of the supply chain (asset visibility, asset availability, and order management). Some responsibilities of the section include handling the day-to-day operations of in-transit visibility of all assets that leave the SMU, ensuring the hardware as well as web applications works properly and training individual units on the use of the system and equipment. This is the specific section I visited while in Camp Pendleton for my data collection.

3. Benefits of ITV

After interviewing several individuals at the SMU in Camp Pendleton the author's sense was that there existed an overall consensus as to the main benefit of ITV in its current state: an increase in the customer's confidence in the supply system. This particular benefit leads to other factors that can improve the SMU's ability to provide excellent support to the supported unit. Once a customer has an increased confidence level in the supply system the rate of cannibalization⁷ will decrease. Also when a unit knows that their requisitioned item is at least en route or at a certain camp, the rate of multiple reorders will decrease as well, which has the affect of saving the government money as well as decreasing the demand on the SMU.

⁷ Process of removing serviceable parts from a damaged item for use in repair of other equipment of the same kind.

The Marines in the customer service section of the SMU provide service primarily to units who are currently deployed with a Marine Expeditionary Unit (MEU), therefore are usually out to sea. These units do not have the access to the ITV websites. The ITV system currently employed by the Marine Corps has increased the SMU's ability to provide accurate information as to the current location of the deployed unit's gear. ITV also speeds up the movement of supplies by eliminating the need to rummage through large containers trying to find a part. If the movement of supplies increases then we have a domino effect of assets reaching units much quicker than anticipated thus increasing the unit's confidence in the supply system.

B. MARINE CORPS SUPPLY PROCESS

Units within I MEF use Asset Tracking for Logistics and Supply System (ATLASS I) to keypunch their requisitions and other related transactions to submit to the SASSY update cycle. Each unit creates a courier that has to be sent to the Operations section of the SMU by 1700 each day via the Operations' section email address, the FTP site, or emailed directly to an Operations clerk. All couriers are integrated and processed in Albany, GA where daily reports are created and sent to each supporting unit. Each unit is responsible for managing their reports as well as their requisitions. The supporting unit must ensure each error and exception is reviewed, corrected, and re-inducted as required. [9]

The system checks SMU's current warehouse on hands to determine if a Material Release Order⁸ (MRO) will be submitted to the SMU. If the item is on hand at the SMU's warehouse a MRO will be created and the Storage Section Marines will 'pick' the item and prepare it for shipment. Preparing the item for shipment involves pulling the item from the warehouse location, packaging the item, labeling the item and creating a manifest. Once the manifest is created it is transferred onto an active RFID tag. Once the identification data is loaded onto the RFID tag a using unit can potentially go online to the LTMITV website and see that the item they requisitioned is at the SMU and ready for shipment. This is the point in which ITV or simply asset visibility begins.

By 1500 all items that will be shipped the next morning are taken over to TMO where they are staged on the trailers overnight. The next morning, depending on the destination, the parts will be transported to the using unit at a certain time. While the parts are at TMO, ITV is available as well. In other words, a unit can see that their part is sitting at TMO waiting to be transported.

While the part is in-transit, if the W2W portal is not working properly, the using unit will only be able to know the last known location of the part based on the location of the interrogators. Otherwise the using unit will have the most recent GPS coordinates of their part. While the items are in-transit from TMO to their destination the user has ITV. After the part arrives at the destination it is

⁸ Document created each night once the couriers are processed. The MRO denotes that the SMU has the item on hand and gives the SMU the authority to release the item for issue. [10]

signed for by a designated individual at the using unit. Once the part is signed for, the LTMITV site is updated to reflect that the item is no longer in-transit.

If the SMU does not have the item on hand then based on the priority of the item the requisition is either automatically forwarded to an appropriate source of supply (SOS) (high priority) or the SMU will maintain the backorder (low priority) and wait until the item is shipped to them. Once the item arrives it is included on a manifest and the identification data is transferred to an active RFID tag then it goes through the same process as before. All items that are en route from the SOS to the SMU are not tagged and therefore ITV does not exist. If a unit has a high priority item then the only visibility they have on the item is the status that is on their DASF. It is not until the item reaches the SMU and the item is tagged that ITV begins. [10]

IV. ANALYSIS

A. ASSUMPTIONS

Assumptions were critical in the analysis of the simulation developed by the author. Where possible, assumptions are supported by information received during interviews, literature review or research that the author conducted. However, several assumptions were based on the opinion of the author due to her experience as a Supply Officer. Due to the lack of access to resources (i.e. equipment, using units, and data) and the fact that the supply process has many moving parts, the author based the simulation on a static environment vice a dynamic one.

There are several simplifying assumptions that are made for the sake of parsimony. While the real-world supply chain process does not exist in the perfect environment suggested by these assumptions, they are necessary to keep the simulation model tractable. The author believes the simulation model built on these assumptions can still inform decision making, but the assumptions are detailed here so that the reader may form their own judgment. The first assumption is that the Marine Corps' Supply System is available at all times, meaning during the running of the simulation there was never a malfunction or unintentional shut down. A second assumption is that all pertinent resources are available to process a request from a unit, to include: personnel, packing and packaging equipment, transportation assets, and RFID hardware/software. A third assumption is that the using unit who requested the part(s) was available to

receive the item(s). Another assumption is that the ITV system (web site and server) is available for view by the SMU as well as the using unit at all times. A final environmental assumption is that the simulation will model the supply process in Camp Pendleton and not in Iraq this is because Camp Pendleton has relevance for a deployed setting as a best case scenario.

In addition to the environmental assumptions, a simplifying assumption is also made based on the military's priority system. The type of priority number a unit can use is determined by the unit's Force Activity Designator (F/AD) along with the Urgency of Need Designator. The F/AD depends upon whether or not a unit is in combat, deployed, maintaining combat readiness, or is a reserve unit; denoted by Roman numerals I-V, with Roman numeral I being assigned to a unit currently in combat. The Urgency of Need Designator is determined by the requisitioning activity, based upon the urgency in which that activity needs the item; denoted by alphabets A-C, with A having the highest urgency. [13] For this simulation the author assumes that low priority designators are 07 - 15, while high priority designators are 01 - 06. This assumption is reinforced by the fact that at some point in the simulation the author breaks the model into three separate sub-models: one sub-model to continue the simulation if the SMU has the demand on hand, a second sub-model to continue the simulation if the SMU does not have it on hand and the priority is low, and a third sub-model to continue the simulation if the SMU does not have the demand on hand and the priority is high.

In addition to simplifying the priority structure, other assumptions have been made to simplify the process in ways which do not limit the essential applicability of the analysis. A second assumption is that all parts are being transported to the same location. The author assumes that only Camp Pendleton units are ordering the parts. A third assumption is that all requisitions are keypunched into ALTASS I by 0730 and are batched until 1730 where they are then further processed. In reality requisitions can be keypunched from 0730 until it is time to create the courier. The courier is a file that contains a list of transactions, keypunched by each using unit's supply clerk, that need to be processed. The assumption that all requisitions are keypunched at 0730 does not nullify the simulation since transactions are not sent to the next step until 1730 anyway. This assumption will be modified in two of the scenarios by simulating a real-time ordering process instead of this batch ordering process. A fourth and final assumption to simplify the simulation is that once a part is received by the SMU from a SOS (it was placed on backorder), it will take at least 24 hours before the part will be shipped to the using unit. The part will need to be added to a container that has an active RFID tag then the container has to be transported to TMO and await shipment. This assumption is reinforced further due to the fact that each day gear ready for shipment is staged at TMO and leaves the next morning at 0800. Any items that arrive after the truck has left must wait until the next day to be shipped. The author understands that the time will vary based on when the item was received but an assumption of 24 hours was logical.

As stated earlier in the thesis, increased customer confidence has been found to be the primary impact ITV has had on the Marine Corps' Supply Process. It is assumed that an increase in customer confidence will result in a reduction in excessive requisitions or multiple re-orders. The RFID technology itself has provided the SMU with the ability to allow the commander to track critical items. This in turn will increase the customer's confidence in the supply system because if they know where the critical items are then they are less likely to consistently burden the SMU and request the item on multiple occasions. In the opinion of the author this advantage is only viable if the SMU has the part on hand because, as of right now, if an item goes on backorder the SMU will not have ITV on the item until the SMU receives the item. The SOS will however record a shipping transaction on the receiving unit's DASF, which lets them know that the part is at least on its way. Some SOS's even possess their own tracking system that is not yet compatible with the Marine Corps' LTMITV. It is logically assumed that the lack of visibility from the time the backordered part is ordered until it reaches the SMU can potentially cause the using unit to return to old habits of re-ordering a part or (worse) cannibalizing another end item.

B. SIMULATON MODEL DESCRIPTION

Arena software was used to develop the simulation. The simulation was built to model the current Marine Corps Supply Process, or the As-Is. This model will be modified for each scenario. The model shows the steps that a demand goes through after it is inputted into the supply system.

Refer to Figure 6 for an overview of the entire simulation and Figures 7, 8, and 9 for each sub-model respectively.

The simulation begins once a battalion creates a demand and ends once the battalion has received the item. The author will run 100, 1000-day periods of the simulation model. It starts at 0730 in the morning and runs for 1000 days using 24 hours to equal one day. All times are returned in hours to remain consistent throughout the simulation.

At the start of the simulation battalions create demands (denoted by 'Battalions Create Demands' create module) and a variable is created to track the total number of demands created in that day. These demands are stored on the using units' computer system until the courier is created (denoted by 'Create Courier' delay module⁹) and sent to the SMU Operations section by 1730 of that day. The courier is a list of transactions submitted by each using unit to the SMU Operations section. This courier can be sent electronically (via email or a file transfer protocol (ftp) site) or hand delivered (via a CD or diskette). The SMU Operations section processes the courier overnight and returns reports to the using units and/or created MRO for the SMU by 0630 the next day. At this point one realizes that the current supply system does batch processing vice real time processing. Regardless of the priority of an item it will take a minimum of about 23 hours before the unit will even know that the item is available as noted by the 'Batch Delay' record module.

⁹ In Arena, modules are flowchart and data objects that define the process to be simulated. [16]

Once the couriers are processed reports on the status of a request are returned to the using units. If the demand is on hand at the SMU, then an MRO will be created for each demand for issue. If the demand is not on hand at the SMU then it is placed on backorder. If the demand is on hand then the simulation will continue with the 'SMU OnHand' sub-model (See Figure 7). Prior to entering the 'SMU OnHand' sub-model the record module '# On Hand Parts' will count the number of parts that are on hand for that day. The 'Pull and Pack Request' delay module includes the storage section pulling all items that have an MRO, packing, packaging, labeling, and adding the item to an RFID manifest, as well as transporting the item to TMO. The 'Pick and Batch Delay' record module will return the average delay of the batch as well as the time it takes storage to pick the request. The 'TMO Delay' module is the delay from the time the part arrives at TMO until 0800 the next day when it is transported to the using unit. The 'Drive to Local Unit' delay module is the transportation time from TMO to the using unit. The last two record modules are for data collection. Once the part has been received by the unit the simulation ends.

At this point we return to the 'On Hand at SMU' decision module. If the demand is not on hand, the simulation flows into the 'Low Priority' decision module. If the priority is low the simulation then flows into the 'Backorder by SMU' sub-model (See Figure 8). Once again the '# Low Priority Backorders' record module will count the number of demands requested that were not on hand at the SMU and were placed on backorder as well as are low priority (priority 07-15). The 'SMU Awaiting Delivery'

delay module represents the probable time delay it will take a part to arrive, if it is placed on backorder by the SMU. Once the SMU receives the demand, the item needs to be tagged and shipped to the using unit. As you can see there is no pick and pack delay because the SOS ships the item directly to the SMU who then forwards it to the appropriate using unit. (In other words, we do not model the SOS warehousing operations, but treat them as a black box.) After speaking to personnel at the SMU the author determined that the time to add the part to an active RFID tag's current manifest and the wait time at TMO is 24 hours, thus the 'TMO and RFID' module delay is a deterministic delay of 24 hours. The transportation to the local units module (denoted by 'Drive to Using Unit_SMU_BO') has the same distribution as the 'SMU Onhand' sub-model's 'Drive to Local Units' delay module. Once again, the final two record modules are for data collection and the simulation ends when the unit receives the part.

Once again we return to the 'On Hand at SMU' decision module, which is still false. Then flow to the 'Low Priority' decision module, which is now false. This means that the demand was not on hand at the SMU and the priority was high. Another record module is used to count the number of demands that are not on hand at the SMU and have a high priority, entitled '# High Priority Backorders.' Next the simulation flows into the 'Backorder by SOS' sub-model (See Figure 9). Once the SOS receives the request they will either send a shipping status to the requesting unit (if they have it on hand) or a backorder status (if the item needs to be manufactured, acquired etc...) to the unit. The 'SOS Manufacturing and/or Shipping to SMU' delay

module represents the probable time delay it will take a part to arrive if it is placed on backorder by the SOS. The 'RFID and TMO' and 'Drive to Using_Unit_SOS_BO' delay modules are the same as the 'Backorder by SMU' sub-model. Finally the two record modules are for data collection and when the unit receives the part the simulation ends.

C. METHODOLOY

The author's research methodology included a literature review and background interviews from individuals who assisted in the development of the ITV system or individuals who are currently using the system. Travel to Camp Pendleton allowed the author to witness firsthand how the current system works; The author was able to collect data as to the location of the interrogators, the system the end users use to track their parts, the current supply process, pertinent data associated with a requisition as it goes through the process, and any tangible or intangible benefits of using LTMITV/W2W in the supply distribution process. The author was also able to collect reports for over 30 days to use to develop probability distributions for random time variables in the simulation model. Finally a simulation tool (Arena) was utilized to study the current supply process and point out any weaknesses or possible improvements that need to be made to the process, as it relates to ITV.

Several distributions were created in order to model the time variances of the simulation. For the percentage used to give a probable fill rate for orders placed by using units, it is important to note that the author will not be modeling detailed inventory positions and queues of backlogged requests (which might be expected in a warehouse

simulation, for example) but will rather take a high level view of availability across items, and will assume this can be modeled adequately with a single random variable. This is appropriate for this thesis because the point of the analysis is the difference ITV makes given certain stocking levels, not to investigate the quality of the stocking levels. The author is also not going to model a detailed order picking process, with individual picks or batches of picks processed while other picks wait in queue. Rather, the author will model only an aggregate completion time for the order pick process. Both of these high-level views of the supply process are sufficiently detailed to allow the author to compare the scenarios.

1. Data Collection

The majority of the data for the thesis was collected while the author visited the SMU the week of 22-25 March 2006. Subsequent data was acquired via email. The data was needed in order to develop reasonable time estimates for the simulation. The time it takes a part to traverse through the supply process can be considered to be deterministic at some points but must be modeled with a random variable at other points. The one true known is that all parts are born as requisitions that are keypunched daily by supply clerks and only when the demanded part is available for issue it becomes tangible and is able to be tracked through the use of ITV. The working assumption with ITV seems to be that visibility is only required once the request has been translated into a tangible good. The author believes that this working assumption may be flawed, partly because of imperfect alignment with the SOS information and material flows.

The Unit Performance Report¹⁰ (UPR) (Appendix A) was used to create a probability distribution for the number of demands created in a day from all the using units the SMU supports and for the percentage of time the SMU will have a demand on hand. The complete demands and complete fill values were used for 41 different reports.

A cumulative recycle database was used to collect data for the type of priority for each requisition. This Access Database had a total of 255,053 transactions. Only 81,034 transactions were used to create the probability distribution for the priority of the requisitions because the other 174,019 transactions were submitted by the SMU. The author only wanted to use those transactions that were meant for a using unit.

Daily transaction listings (DTL) (See Appendix B) were received via email on July 20, 2006 from the SMU. [15] The DTL were received from one unit because the SMU does not separately voucher AS1 transactions for all units. The DTL covered October 2, 2005 - April 21, 2006 respectively. The transactions from the DTL were used to gather sample data for low priority and high priority backorder order ship times. There were a total of 235 shipping (AS1) transactions that had a low priority and were backorders filled by the SMU. There were a total of 2800 AS1 transactions that were high priority and were backorders filled by a SOS. In each case the number of data points used were decreased because the order ship times were either greater than one year or less than or equal to 72

¹⁰ The unit performance report provides the supply officer and commander with the number of transactions sent to the SMU, how many were rejected, fill rates, dollar value of gains and losses, the number of back orders, and additional data accumulated.[14]

hours. Since this thesis is focusing on the impacts of ITV and not the supply acquisition process, the author felt that order ship times over one year cover a separate problem that requires its own research. Due to the fact that AS1 transactions do not indicate if the item being shipped is a backorder, the author assumed that order ship times that were less than or equal to 72 hours were issues instead of backorders. These order ship times will be used in the scenario that will simulate the supply process prior to ITV (As-Was) to demonstrate one of the impacts of multiple reordering. It is reasonable to assume that an increase in demands (due to multiple reordering) will burden the supply process in some form. The burden will be depicted as if the storage section was overwhelmed and could not get all picks to TMO by 1500. In the scenario a percentage of demands will not make it to TMO by 1500 and consequently will be delayed for an additional 24 hours.

Another Access Database was used to collect data to reinforce the statement that multiple reordering took place during OIF I due to lack of visibility. On August 16, 2006 the author received a link to an ftp site to access the data. The database included a list of the total demands during OIF I from March 1, 2003 through May 5, 2003 that the SMU had on file. Out of the 85,302 demands 70,757 were placed on backorder. 22,551 of the 70,757 backorders were multiple reorders. Some NSN's were not only reordered twice but three, four, five, and up to nine times, thus 32% of the total backorders were multiple reorders. The 32% increase will be used in two scenarios to represent multiple reordering.

Expert opinion was used on many occasions to collect data for the simulation. Some of the data collected via expert opinion resulted in deterministic as well as probability distributions. An expert opinion was used to determine when and how couriers were submitted to the SMU. It is essential to note that couriers are processed using a batching system. All transactions are collected by each using unit, and at the end of the day the courier is submitted to the SMU Operations section for processing. The courier has to be at the SMU at the same time each day unless otherwise notified. Once the SMU receives the couriers, the time it takes to process the couriers is deterministic. [10] Data was also collected to determine the time it takes for a part to be pulled from location, packaged, and labeled. The list of items that have to be pulled are referred to as 'picks' by the SMU Storage Marines. These picks are created based on the number of MROs that were processed the night prior. The Officer-In-Charge (OIC) of the Storage Section gave the author the best, worse, and most likely times that the section completes all picks in a day. The OIC also informed the author that once the items were ready for shipment they had to be transported to TMO and staged. All items that are to be shipped the very next day must be at TMO by 1500, unless of course there is a last minute high priority request. The final data collected using expert opinion related to the transportation times from TMO to the using unit. These times depend upon the location of the using unit. The SMU supports units on the same base, Camp Pendleton, units stationed at MCAS Miramar, MCAS Yuma, 29 Palms, and Iraq.

Only Camp Pendleton transportation times will be used in the simulation.

Other miscellaneous data was collected to integrate the entire simulation and develop a reasonable elapsed time for a requisition throughout the process. These consisted of the delay between the time the requisition was keypunched until the courier was created, the delay time while the items are at TMO awaiting shipment and the exact locations within the simulation where ITV existed.

D. VARIABLES AND PARAMETERS

The simulation developed uses quantitative modeling to demonstrate the Marine Corps' Supply Process under varying scenarios. The variables modeled must be either deterministic or random. Choosing the way in which one models a variable can sometimes be obvious. For example, courier process time is a simple constant. Others are not so clear, like number of demands the SMU gets in one day. In those cases, Arena's Input Analyzer can help in developing probability distributions.[16] Each distribution used in the simulation will be described from the beginning of the simulation until the end. The reader can refer to Figure 6 to view a snap shot of the modules in the simulation. See Table 1 for a summary of all distributions.

Arena's Input Analyzer has the choice of 12 different distribution types to include Normal, Beta, Erlang, and Triangular. After fitting a set of data to each of these analytical distributions, it gives the p value as well as test statistic (denoted by D) of the Kolmogorov-Smirnov goodness-of-fit test. The user can choose the distribution they prefer, however, the Input Analyzer will recommend the

best distribution to use based on the goodness-of-fit test. The author has chosen to accept the recommended distribution by Arena for three of the four random distributions (total demands, fill rate, and high priority shipping times) but not for the low priority shipping times. The distribution chosen by the author in the latter case had an acceptable fit to the data, and was a more realistic indication of how the data reflects the supply process.

1. Total Demands Distribution

Inside the 'Battalions Create Demands' (Figure 6) module the number of demands the SMU receives in one day is used to start the simulation. The data collection involved getting 41 days of the SMU's Unit Performance Report (See Appendix A). The column of interest is entitled 'Total Demands'. The value to the right of the column was different for each of the 41 days. It ranged from as low as 18 demands to as high as 2630 demands. A text file was created which listed each demand from day 1 to day 41. This text file was imported into Arena's Input Analyzer and a distribution was created. The Input Analyzer recommends modeling the number of demands the SMU creates in a day with a normal distribution that has a mean of 825 and a standard deviation of 508 (see Figure 3). The corresponding p value for the Kolmogorov-Smirnov Test was equal to 0.0203 with the test statistic (D) equaling .233. A Normal Distribution is invoked in Arena using the expression NORM [825,508].

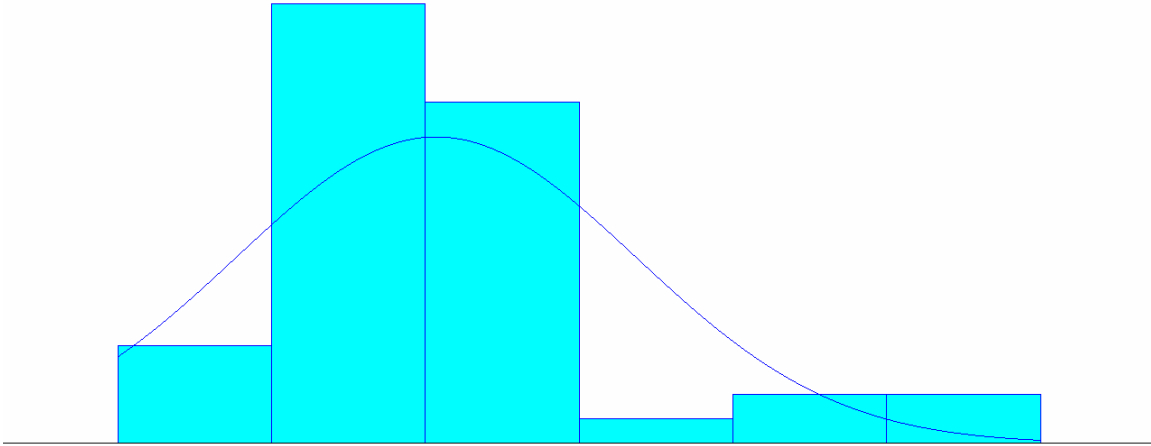

Figure 3. Total demands distribution with normal expression: $NORM[825,508]$ (From [16])

The variables that are created to denote the total demands are listed below:

- # On Hand Parts Delivered - denotes the number of parts that the SMU had on hand and were delivered to the unit
- # SMU Parts Delivered - denotes the number of low priority backorders that were actually delivered to the using unit
- # SOS Parts Delivered - denotes the number of high priority backorders that were actually delivered to the using unit

The goal of the supply process is that the number of demands that are created equals the number of demands that are eventually delivered.

2. Courier and Process Delay Distributions

Following along with Figure 6 and the simulation, the next two parameters are deterministic. The first deterministic parameter occurs upon the creation of the

courier (list of transactions), found in the 'Create Courier' module. As stated in the assumptions all demands will be created at 0730. Since the couriers have to be submitted to the SMU Operations Section by 1730 each day the delay time is 10 hours. This delay is denoted by the variable 'Courier.'

A second deterministic distribution is located in the next delay module entitled 'SMU Operations Processes Couriers.' Once each using unit submits their courier for processing this module simulates the actual processing time. Each morning by 0700 the results of the couriers are posted in the form of reports to the using units. The delay time is 13.5 hours. The 13.5 hours is derived from the using unit's submission of the courier at 1730 the previous day and the courier processing completion at 0700 the following day. This delay is denoted by the variable 'Process Batch.' These two delays: 'Courtier' and 'Process batch' variables are collectively referred to as the total batch delay. Two scenarios will be created to possibly eliminate and/or reduce the batch ordering process by simulating a real-time ordering process.

3. Fill Rate Probability

Continuing with the simulation found on Figure 6, there is a decision module entitled 'On Hand at SMU.' The UPR (Appendix A) was used once again to collect data in order to determine the probability that the SMU would have the demand on hand. This is denoted by the column entitled 'Total Complete Fills' on the UPR in Appendix A. The complete fill or fill rate is the percentage of the number of demands the SMU received versus what the SMU actually has on hand. This value takes into consideration all

demands that come through the SMU, even those items that the SMU never carries, such as an actual tank. If the SMU carries an item they will have an RO or requisitioning objective¹¹ for it. There is another column entitled 'Complete RO Fills', this percentage is normally larger than the complete fill percentage but it was not used because this thesis is examining the supply process from the using unit's perspective. All the using unit has to do is place the requisition and if the SMU does not carry the item the request will be forwarded out of house to a SOS who can supply the item. The probability was created by taking the average fill rate of the 41 data points. Based on the 41 days of UPRs an average fill rate of 61.3221% was computed. The variables created to track the fill rate are listed below:

- # On Hand Parts - denotes the number of parts that the SMU will have on hand as determined by a random number of demands requested
- # On Hand Parts Delivered - denotes the number of parts that the SMU had on hand and were delivered to the unit

The # On Hand Parts returns the number of demands that are on hand at the SMU based on the value generated by the total demands distribution. This is the initial fill rate. The # On Hand Parts Delivered denotes the number of parts that the unit actually received. This number could be different from the # On Hand Parts based on the scenario. This is the true fill rate since the simulation is from the

¹¹ The SMU can carry a specific amount of an NSN in order to fill demands. Value can easily be changed by the SMU.

point of view of the using unit. What should be seen is that with ITV these two numbers should always be equal to each other.

4. Backorder Priority Probability

At this point in the simulation a requisition can follow three different paths: it can flow into the 'SMU Onhand' sub-model, the 'Backorder by SMU' sub-model or the 'Backorder by SOS' sub-model. The requisition will flow in the two latter sub-models only if the 'On Hand at SMU' decision module is false. If the SMU does not have the item on hand then the 'Low Priority' decision module will be the next step. This is where the next distribution is found. Recall that a low priority requisition will have a priority between 07 and 15 while a high priority requisition will have a priority between 01 and 06. The type of priority probability distribution was created by using the 81,034 transactions from the recycle database retrieved from the SMU. The total number of each priority designator was used to create a percentage based on low priority and high priority. The probability or chance that the transaction that is placed on backorder will have a low priority is 48.624%. Conversely the probability or chance that the transaction that is placed on backorder will have a high priority is 51.376%. The variables created to track this distribution are listed below:

- # Low Priority Backorders - denotes the number of parts that will be placed on backorder by the SMU as determined by a random number of demands requested

- # High Priority Backorders - denotes the number of parts that will be placed on backorder by the SOS as determined by a random number of demands requested

If the 'Low Priority' decision module is true then the simulation will increase the # Low Priority Backorders variable by the number of demands that flow through that route of the simulation, flowing into the 'Backorder by SMU' sub-model. If the 'Low Priority' decision module is false then the simulation will increase the # High Priority Backorders variable, flowing into the 'Backorder by SOS' sub-model.

5. 'SMU OnHand' Sub-Model Distributions

At this point we will return to the 'On Hand at SMU' (see Figure 6) decision module and assume that the SMU does have the demand on hand. If the SMU has the demand on hand the simulation will flow into the first sub-model entitled 'SMU OnHand.' See Figure 7 for a detailed view of this sub-model. There are three different delay modules, each with their own distribution. The first delay module entitled 'Pull and Pack Request' represents the time it takes the SMU storage section to pull, package, and label the part as well as add the part to a RFID tagged container. Based on expert opinion given by the Storage Section OIC the author used a Triangular Distribution for the amount of time it takes for the Marines to pull the gear, pack it, label it, and load the manifest information into the active RFID tag. The following data was given:

- Best case scenario: All 'picks' can be pulled, labeled, packed, and manifested by 1000.

- Worse case scenario: All 'picks' can be pulled, labeled, packed, and manifested by 1400.
- Most likely scenario: All 'picks' can be pulled, labeled, packed, and manifested by 1100.

The distribution is given by the expression TRIA [3, 4, 7] hours. Remember the MROs are available at 0700 each day. This delay is denoted by the variable 'Pick Delay.'

Continuing in the 'SMU On Hand' sub-model, all items to be shipped the next day are to arrive at TMO by 1500 each day. Since the pick delay will determine when an item will be sent to TMO the delay time at TMO was determined also based on a triangular distribution. In order to create the triangular distribution the author first determined how many hours a part would sit at TMO if it arrived there between 1000 and 1400. These times created a distribution between 18 and 22 hours. Using the best, most likely, and worse case values from the pick delay the author determined the TMO delay has a Triangular Distribution of 18, 21, and 22 hours, shown by expression TRIA[18,21,22]. No variable is used to track the TMO delay.

The final distribution for the 'SMU On Hand' sub-model is for the amount of time it takes the parts to be delivered to the unit from TMO. This distribution is found in the 'Drive to Local Units' delay module of Figure 7. This distribution was based on expert opinion given to the author by SMU personnel. The delay time was given with a Uniform Distribution of two to four hours, using the expression UNIF [2,4] hours. This distribution represents the average travel time to a using unit if they were located on Camp Pendleton. Travel time is important

because the further the destination the longer the trip and the route the driver takes also affects travel time. All supply distributors must consider the final destination when estimating the receipt time of an item.

All of the distributions in the 'SMU OnHand' sub-model including the courier, process couriers, and fill rate distributions determine the final order ship time, denoted by the outcome variable 'On Hand OST.' This variable is given in hours and will return the amount of time it takes a unit to receive a part that has been requested if the SMU has the part on hand.

6. 'Backorder by SMU' Sub-Model Distributions

At this point we return to Figure 6 to the 'On Hand at SMU' decision module. If this is false (i.e., if the demanded item is not on hand) the simulation flows into the 'Low Priority' decision module. If this module is true then the simulation will flow into the 'Backorder by SMU' sub-model. See Figure 8 for a detailed view of the 'Backorder by SMU' sub-model. As stated earlier this sub-model will only be activated if the SMU does not have a demand on hand and the priority is low. The type of priority is important because the low and high priority distributions are different. There are three different delay modules in this sub-model: 'SMU Awaiting Delivery', 'TMO and RFID' and 'Drive to Using Unit_SMU_BO.' Each delay module has a separate distribution.

The first delay module, 'SMU Awaiting Delivery' distribution relates to the how long it will take the SMU to receive an item that was placed on backorder and has a low priority. Arena's Input Analyzer was used once again to

create the probability distribution. A total of 183 data points were used to fit an Exponential Distribution, denoted by the expression $[120 + \text{EXPO}(221)]$. The corresponding p value for the Kolmogorov-Smirnov Test was less than 0.01 with D equaling .146. See Figure 4.



Figure 4. Shipping Times for Low Priority Backorders with expression: $[120 + \text{EXPO}(221)]$ (From [16])

A range of percentile estimates as well as an average value of the 183 data points that were used to create this distribution will be computed. The outcome variable '#SMU Parts Delivered' is directly associated with the low priority order ship time because if the simulation is ran for a long time (i.e., 1000 days) the value of this variable should equal the '#Low Priority Backorders' but if the simulation is ran for a short time (i.e., 30 days) the value of this variable will be less than the '#Low Priority Backorders' value due to the long order ship times.

The next delay module is the 'TMO and RFID' module. As stated in the assumptions once the SMU receives the part that it placed on backorder for the using unit a deterministic delay of 24 hours was used to cover the attachment of the RFID tag and the wait at TMO.

The final delay in this sub-model is the 'Drive to Using Unit_SMU_BO' module which is the travel time from TMO to the using unit. The travel time to the unit has the same uniform distribution (UNIF [2,4] hours) as in the 'SMU OnHand' sub-model.

All of the distributions in the 'Backorder by SMU' sub-model including the courier, process couriers, and backorder priority distributions determine the final order ship time, denoted by the outcome variable 'SMU OST.' This variable is given in hours and will return the amount of time it takes a unit to receive a part that has been requested, which is not on hand at the SMU, and has a low priority.

7. 'Backorder by SOS' Distributions

Once again we need to return to Figure 6 to the 'On Hand at SMU' decision module. If this is false (i.e., if the item demanded is not on hand) then the simulation flows into the 'Low Priority' decision module. If this is false as well (i.e., if the item demanded is high priority), then the simulation will flow into the 'Backorder by SOS' sub-model. See Figure 9 for a detailed view of the 'Backorder by SOS' sub-model. As stated earlier this sub-model will only be activated if the SMU does not have the demand on hand and the priority is high. There are three different delays modules in this sub-model: 'SOS Manufacturing and or Shipping to SMU', 'RFID and TMO', and 'Drive to Using Unit_SOS_BO.' Each delay module has a separate distribution.

The first delay module, 'SOS Manufacturing and or Shipping to SMU' distribution will provide the approximate

delay of how long it will take an item to be received by the SMU from the SOS if the item is originally not on hand at the SMU and has a high priority. A total of 2361 data points were used to fit a Beta Distribution denoted by the expression $[120 + 6.58e+003 * \text{BETA}(0.674, 2.21)]$. The corresponding p value for the Kolmogorov-Smirnov Test was less than 0.01 with D equaling .122. See Figure 5.

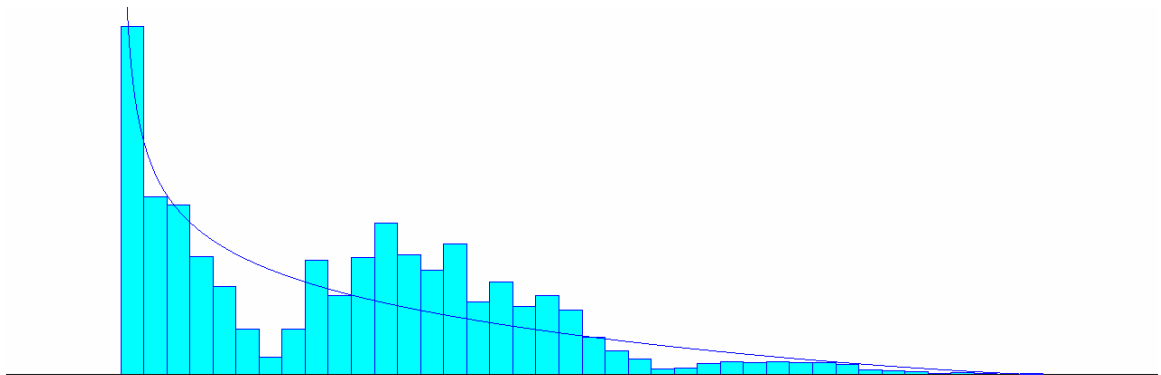

Figure 5. Shipping Times for High Priority Backorders with expression: $[120 + 6.58e+003 * \text{BETA}(0.674, 2.21)]$ (From [16])

A range of percentile estimates as well as an average value of the 2361 data points that were used to create this distribution will be computed. The outcome variable '#SOS Parts Delivered' is directly associated with the high priority order ship time because if the simulation is ran for a long time (i.e., 1000 days) the value of this variable should equal the '#High Priority Backorders' but if the simulation is ran for a short time (i.e., 30 days) the value of this variable will be less than the '#High Priority Backorders' value due to the long order ship times.

The next delay module is the 'TMO and RFID' module. This delay module denotes the deterministic time delay of placing the part in an RFID tagged container as well as the wait at TMO for shipment. The delay time is the same as the 'Backorder by SMU' TMO and RFID delay which is 24 hours.

The final delay in this sub-model is the 'Drive to Using Unit_SOS_BO' module which is the travel time from TMO to the using unit. The travel time to the unit has the same uniform distribution (UNIF [2,4] hours) as in the 'SMU OnHand' sub-model.

All of the distributions in the 'Backorder by SOS' sub-model including the courier, process couriers, and backorder priority distributions determine the final order ship time, denoted by the outcome variable 'SOS OST.' This variable is given in hours and will return the amount of time it takes a unit to receive a part that has been requested, which is not on hand at the SMU, and has a high priority.

Table 1 is a summary of all distributions that were determined from the data collected.

Module Name	Module Type	Input Type	Distribution Expression
Battalions_C reate Demands	Create	Random	NORM (825,508)
Create Courier	Delay	Deterministic	10 hours
SMU_Operatio ns Processes Courier	Delay	Deterministic	13.5 hours
On Hand at SMU	Decision	Random	61.3321% (True)
Low Priority	Decision	Random	48.624% (True)
Pull and Pack Gear	Delay	Random	TRIA[3,4,7] hours
TMO Delay	Delay	Random	TRIA[18,21,22] hours
TMO_and__RFI D_Delay	Delay	Deterministic	24 hours
Drive to Unit	Delay	Random	UNIF[2,4] hours
SMU_Awaiting Delivery	Process	Random	[120+EXPO(221))] hours
SOS Manufacturin g and/or Shipping	Process	Random	[120+6.58e+003*BETA(0.674, 2.21)]hours

Table 1. Summary of Distributions

E. SCENARIOS

In order to get an appreciation for the affects ITV has had on the Marine Corps' supply process the author will run four different scenarios:

- Base Case (As-Was): The Marine Corps Supply Process Prior to ITV
- Real-Time: Hypothetical System Using a Real-time Ordering Processing System Vice a Batch Ordering Processing System
- As-Is: The Current Marine Corps Supply Process with ITV

- To-Be: The Marine Corps Supply Process Using a Real-time Ordering Processing System Vice a Batch Ordering Processing System

Each scenario will either depict an increase or decrease in multiple reordering and the misrouting of requisitions, since these two were found to be main disadvantages due to a lack of visibility during OIF I. A decrease in multiple reordering and the misrouting of requisitions has been the positive effect that ITV has had on the supply process. The author performed model verification on all the scenarios to ensure that the input parameters performed as expected.

After deciphering the entire supply process the author noticed that the batching of the transactions is a limitation of the Marine Corp's Supply Process. Due to batching, if a unit has a requisition that needs to be filled immediately the using unit has to contact the SMU and inform them that the requisition is being placed in the system but it should not go through the normal channels. The unit has to do what is referred to as a 'walkthrough', so called because personnel from the requesting unit 'walk' the requisition 'through' the supply chain. In many cases the using unit has to travel to the SMU in order to pick up the part themselves. For two of the scenarios (Real-Time and To-Be) the author will simulate using a real-time ordering process instead of a batch process.

1. Base Case (As-Was): The Marine Corps' Supply Process Prior to ITV

The lack of visibility of assets as well as requisitions has caused serious problems in the supply distribution community. The customer did not trust that

their requisitions would be received in a timely manner thus before most major exercises the customer would on many occasions order more parts than they actually needed for their "just in case" stash. These extra orders placed a huge burden on the supply system as well as assisted in the inaccurate assessment of what units need when they deploy. Now let's combine the additional orders placed prior to deploying to combat or prior to a major exercise, with duplicate requisitions during a deployment due to a lack of visibility. At some point it is difficult to assess which parts are actually needed and which are backup. What you have is an overloaded system, potentially exacerbated by excess inventory due to reorders.

In order to simulate the multiple reordering the author will modify the As-Is format of the simulation. The first modification will be made to the 'Battalions Create Demands' create module in which the number of demands created (NORM[825,508]) will be increased by 32%. (Recall from the author's data collection that 32% of the total backorders during OIF I were multiple reorders.) The increase of the total demands as well as the variance by 32% is to conserve variance in the system. By increasing the demands and variance by 32% the distribution for the total demands will be represented by the expression NORM[1089,583] for this scenario. A second modification will be to the 'SMU OnHand' sub-model. As stated earlier it is logical to assume that an increase in demands will burden the supply process in some form. Using the DTL, 207 transactions were found to have an order ship time less than or equal to 72 hours. These 207 transactions were chosen because AS1 transactions do to indicate a backorder,

only a shipment, therefore the assumption was made that order ship times less than or equal to 72 hours are issues that were simply delayed due to the supply system being over-burdened. A total of 3063 transactions were reviewed, thus only 6.75% of the total demands will be delayed by 24 hours. This additional delay should increase the 'On Hand OST' variable. See Figure 10 for the change to the 'SMU OnHand' sub-model.

Misrouting of requisitions was the second major problem due to lack of ITV. Per reference [9] an 11% container recovery rate was attributed to the effective use of ITV which allowed them to "locate loss or misrouted Class IX¹² sustainment containers that originated from Camp Pendleton, CA." [9] In order to depict misrouting of requisitions the simulation will show that 11% of all requisitions never reach the using unit. This change will affect all three sub-models. See Figures 10, 11, and 12 for the change to each sub-model. The additional variables that will be tracked are listed below:

- # OnHand Parts Lost - number of parts that were originally on hand at the SMU when the demands was processed but was lost in-transit due to lack of visibility
- # SMU Backorders Lost - number of backorders that were filled by the SMU but were lost during shipment to the using unit due to lack of visibility

¹²Class IX supply refers to consumable repair parts as well as secondary reparable.

- # SOS Backorders Lost - number of backorders that were filled by the SOS but were lost during shipment to the using unit due to lack of visibility

These variables denote loss shipments due to lack of in-transit visibility. In addition to loss shipments a lack of ITV potentially causes parts to be delivered slower. In order to show the slow travel time the author will also increase the earliest and latest travel times by 12 hours for each one of the sub-models to represent the lack of ITV. This will increase the drive from the local unit's Uniform Distribution from UNIF[2,4] to UNIF[14,16] hours.

2. Real-Time: Hypothetical Improvement Using a Real-Time Order Processing System Vice a Batch Order Processing System

This scenario will take the Base Case (As-Was) and replace the batch ordering process with a real-time ordering process. The creation of the courier at the using unit and the processing of the couriers cause an instant delay of 23 hours before the unit even knows if the part is on hand at the SMU or not. In order to simulate a real-time order processing system the author will change the delay time in the 'Create Courier' delay model from a deterministic delay of 10 hours to a uniform random delay of 0 to 10 hours, represented by the expression UNIF[0,10] hours. The idea behind this distribution is that as soon as a requisition is keypunched it will be processed from the start of the simulation (simulation starts at 0730) until 1730. The 'SMU Operations Processes Courier' delay module will be removed all together because with a real-time ordering system the batching of the couriers no longer

exists. Also in a real-time ordering system the customer can know immediately if the item is on hand, or if it will be placed on backorder. The customer will also know if they made an error in their request because the order would not process correctly. Real-time processing could possibly eliminate the need for a robust supply section in the battalion. Potentially each section could order their parts from their work station and use an intermediate approval authority to ensure the funds were available before the order was processed. Since there is still no ITV, multiple reorders and misrouting of requisitions will be simulated as well using the same parameters as the Base Case (As-Was). The variables used to track the number of parts lost will be tracked in this scenario and the order ship times should be less than the As-Was scenario. See Figure 13 for the modified simulation.

3. As-Is: The Current Marine Corps Supply Process

The current supply process has implemented ITV from the SMU to the using unit. The implementation of ITV has caused an overall increase in the customer's confidence in the supply process which has led to a reduction in multiple reorders. The reduction can be attributed to the fact that the using unit now has the ability to check the last known location, using nodes of the LTMITV system, or the actual location, using the GPS of the W2W system, of a requisition. By knowing either one of these two, the using unit has more confidence that their part will eventually arrive. In order to simulate the reduction in multiple reorders the author will run the simulation using the original total demands distribution of NORM[825,508] vice the 32% increase used in the As-Was and Real-Time

scenarios. If the author's assumptions are correct there should be a noticeable decrease in the order ship times.

Another advantage of ITV is the SMU's ability to locate misrouted containers, which contain requisitions. The addition of ITV has enabled the Commander to be able to track critical items. In order to simulate the reduction or possible elimination of misrouting requisitions the 11% loss requisitions will be reduced to 0%. Also the travel time from TMO to the using unit will be reduced to a uniform distribution of two to four hours. Figures 6 through 9 depict the As-Is scenario, which has been described earlier as well.

4. To-Be: The Marine Corps Supply Process Using a Real-time Order Processing System Vice a Batch Order Processing System

It is commonly said that it is never a good idea to incorporate technology into a flawed process. Usually technology will only magnify the flaws. A completed study for the Office of Force Transformation examined military logistics during OIF in early 2003. The study found that the "current logistics doctrine is not keeping up with the technology." [17] Not only is the Marine Corps' supply system outdated, but according to the 1st Marine Division's Lesson Learned report, as of May 2003 there was no one standard Marine Corps Supply system because "I MEF uses ATLASS I, II MEF uses ATLASS II, [ATLASS I and ATLASS II are not compatible] and Blount Island Command uses a different supply system for Maritime Prepositioning Force (MPF) equipment." [18] In order for ITV to work properly in a combat environment I MEF and II MEF had to agree to use ATLASS I. Since the Marine Corps had to deploy soon after

OIF I, in support of OIF II, the lack of visibility of assets needed to be fixed now. Essentially the Marine Corps is repairing the supply problem in a round about way. Theoretically it could possibly take years to develop a standardized real-time supply system that also incorporates ITV. This next scenario will show the potential changes in the supply process if ITV was used in conjunction with a real-time ordering process.

In order to simulate ITV using real-time ordering process vice a batch ordering process the author will change the 'Create Courier' delay module's delay time to a uniform random delay represented by expression UNIF[0,10] hours as well as remove the 'SMU Operations Processes Couriers' delay module. The remainder of the simulation will be the same as the As-Is scenario. See Figure 13 for the modified simulation.

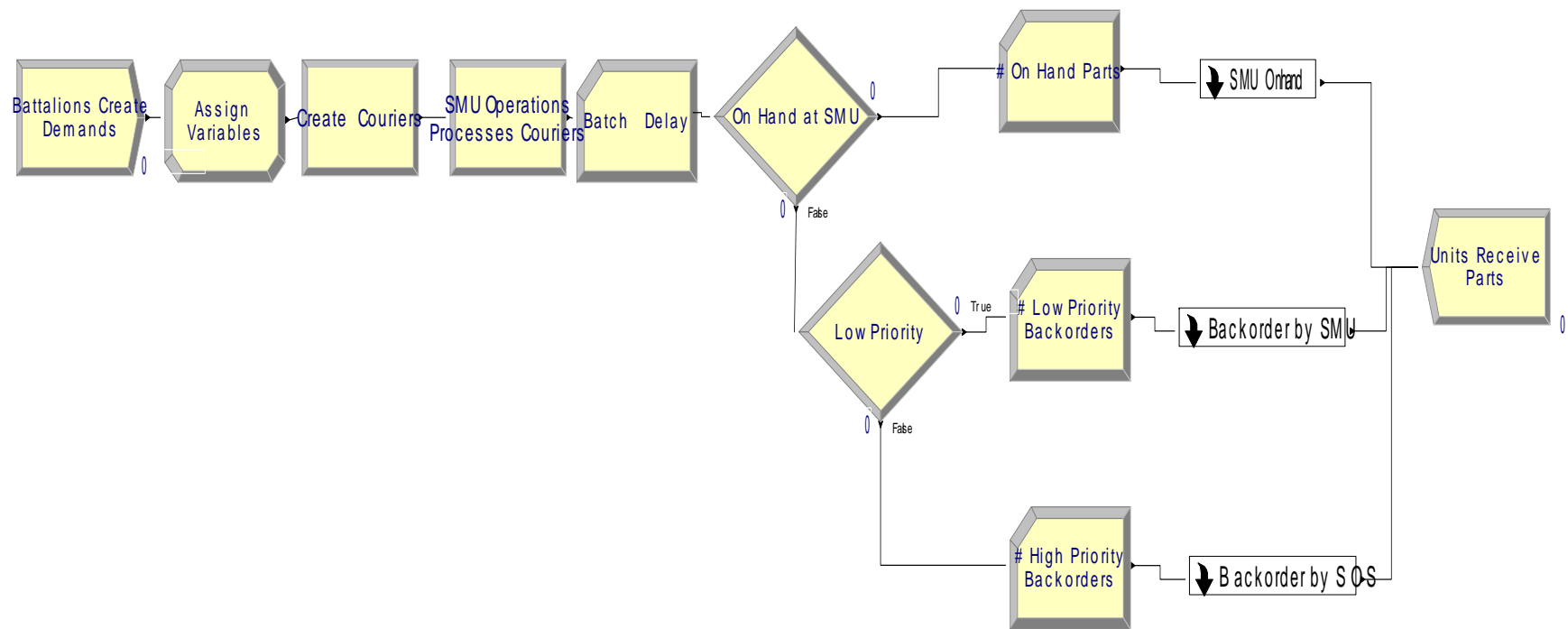

Figure 6. Simulation

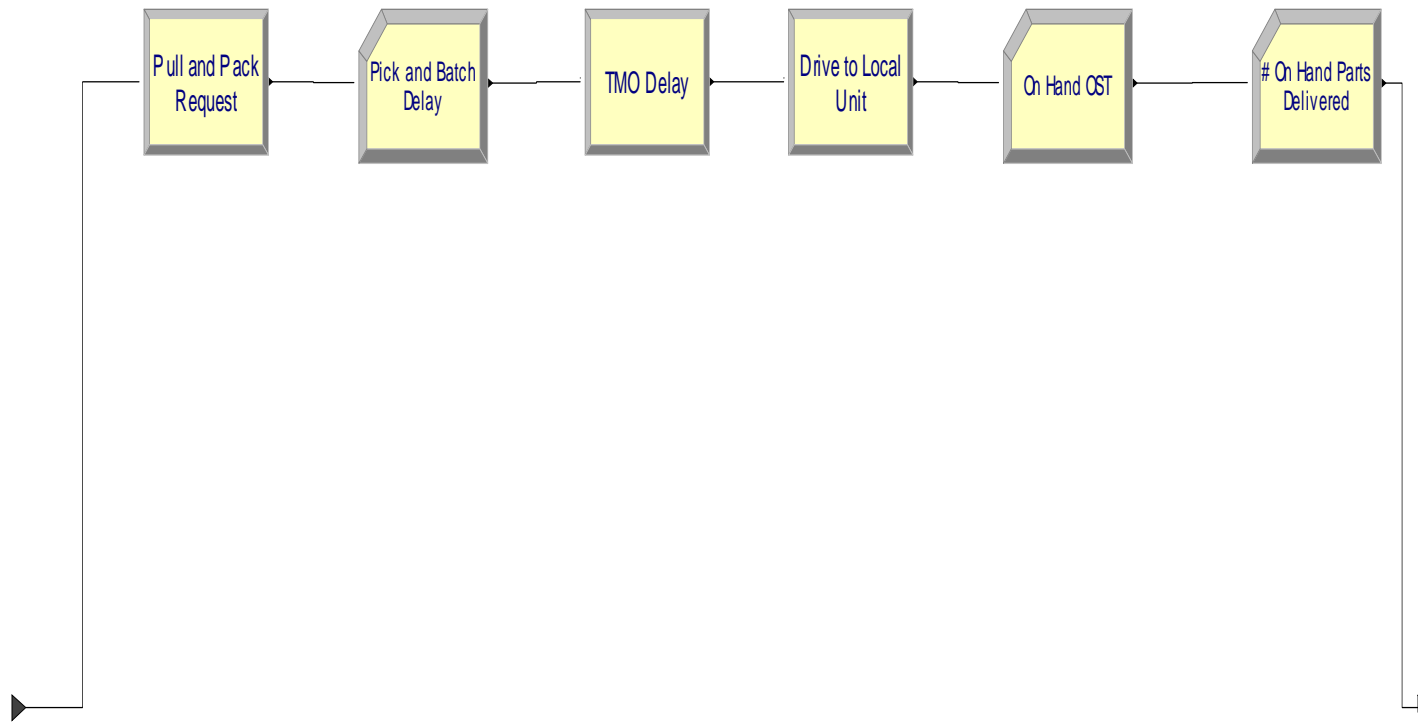

Figure 7. Sub-Model: SMU Onhand

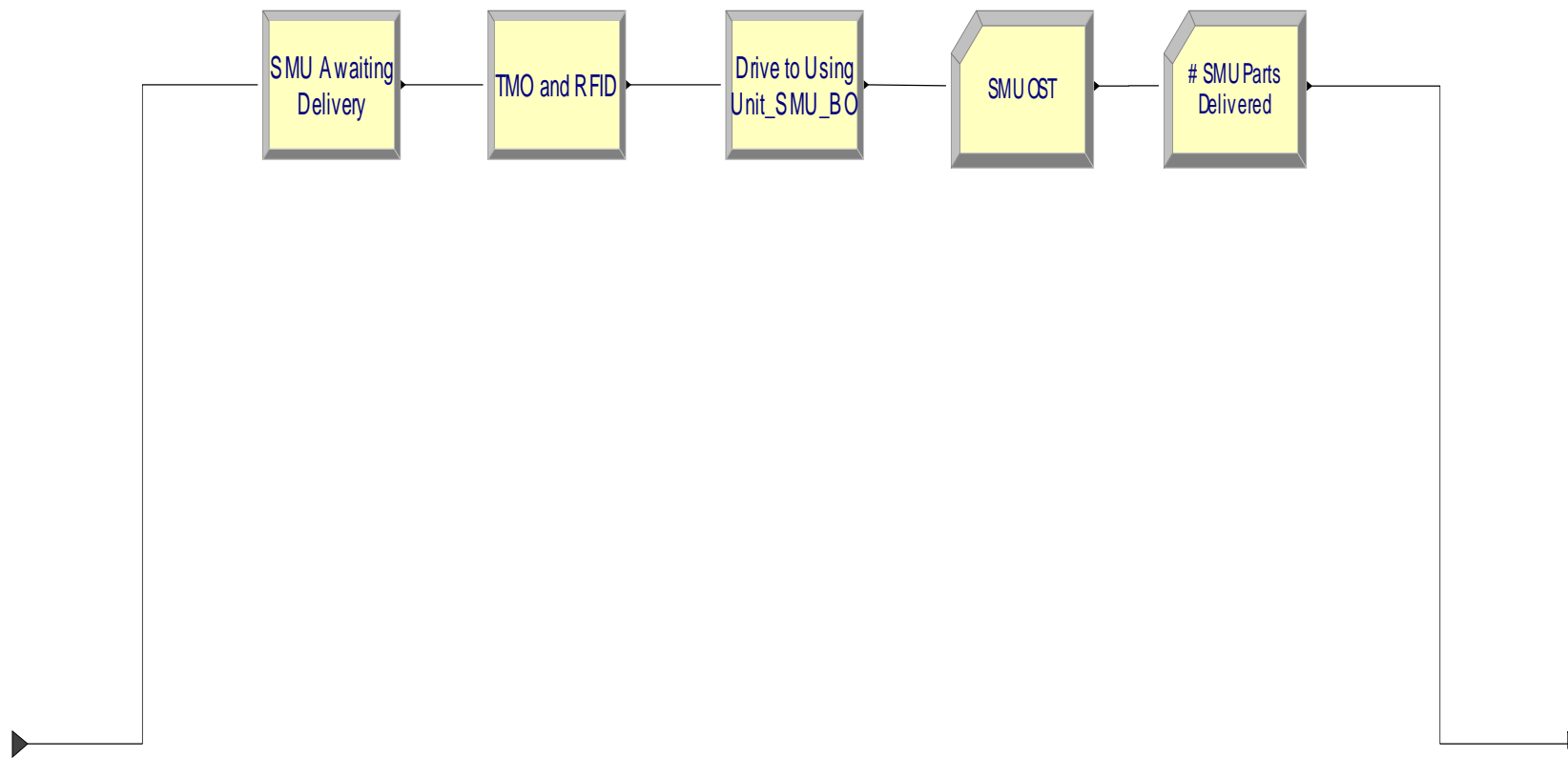

Figure 8. Sub-Model: Backorder by SMU - Not on Hand & Low Priority Backorder

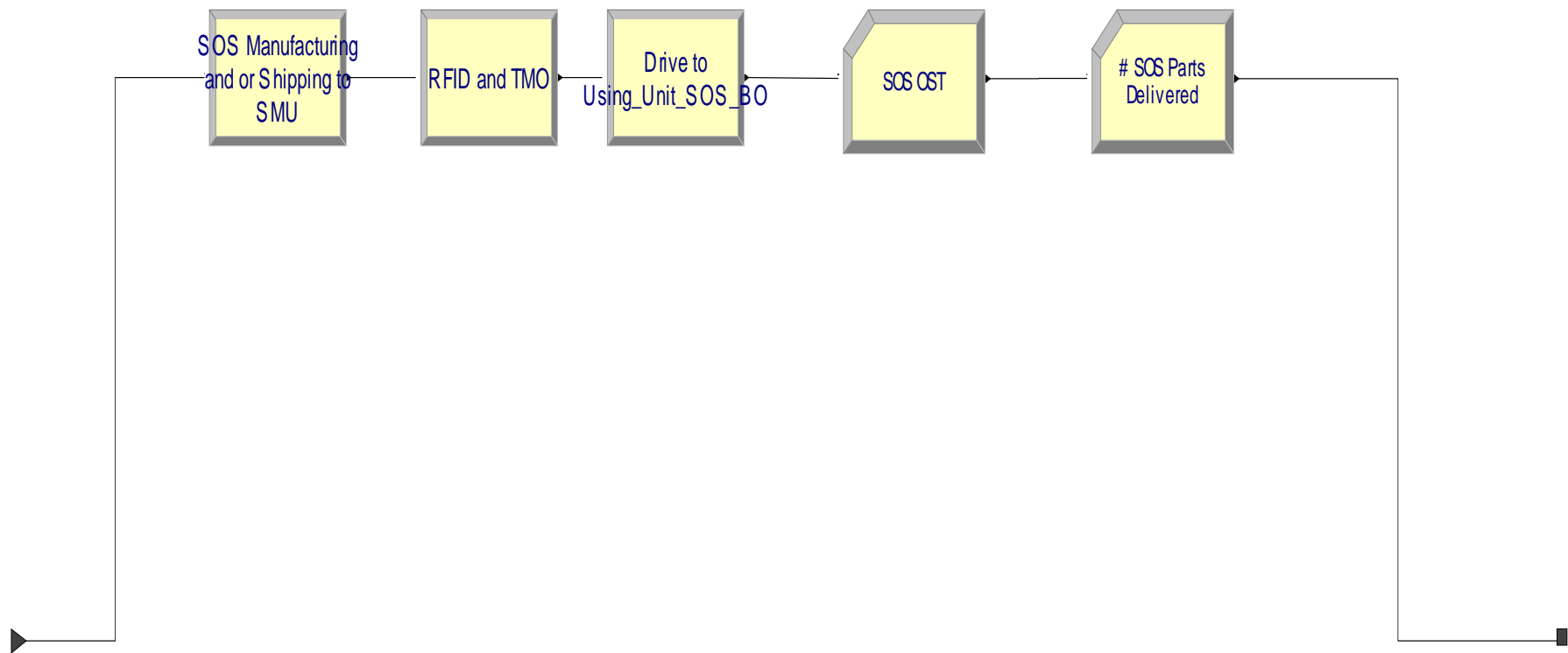

Figure 9. Sub-Model: Backorder by SOS - Not on Hand & High Priority Backorder

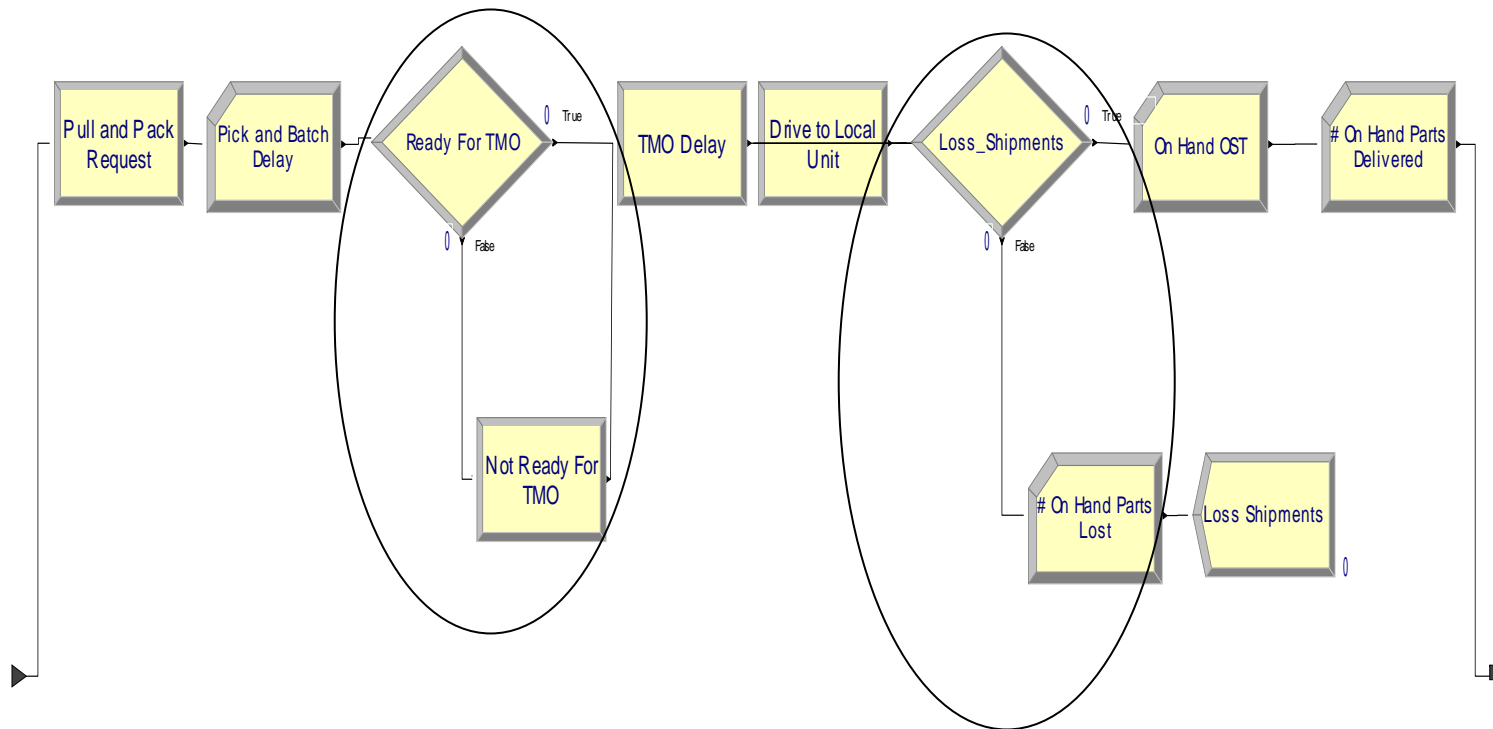

Figure 10. Modified 'SMU OnHand' sub-model for As-Was and Real-Time Scenarios

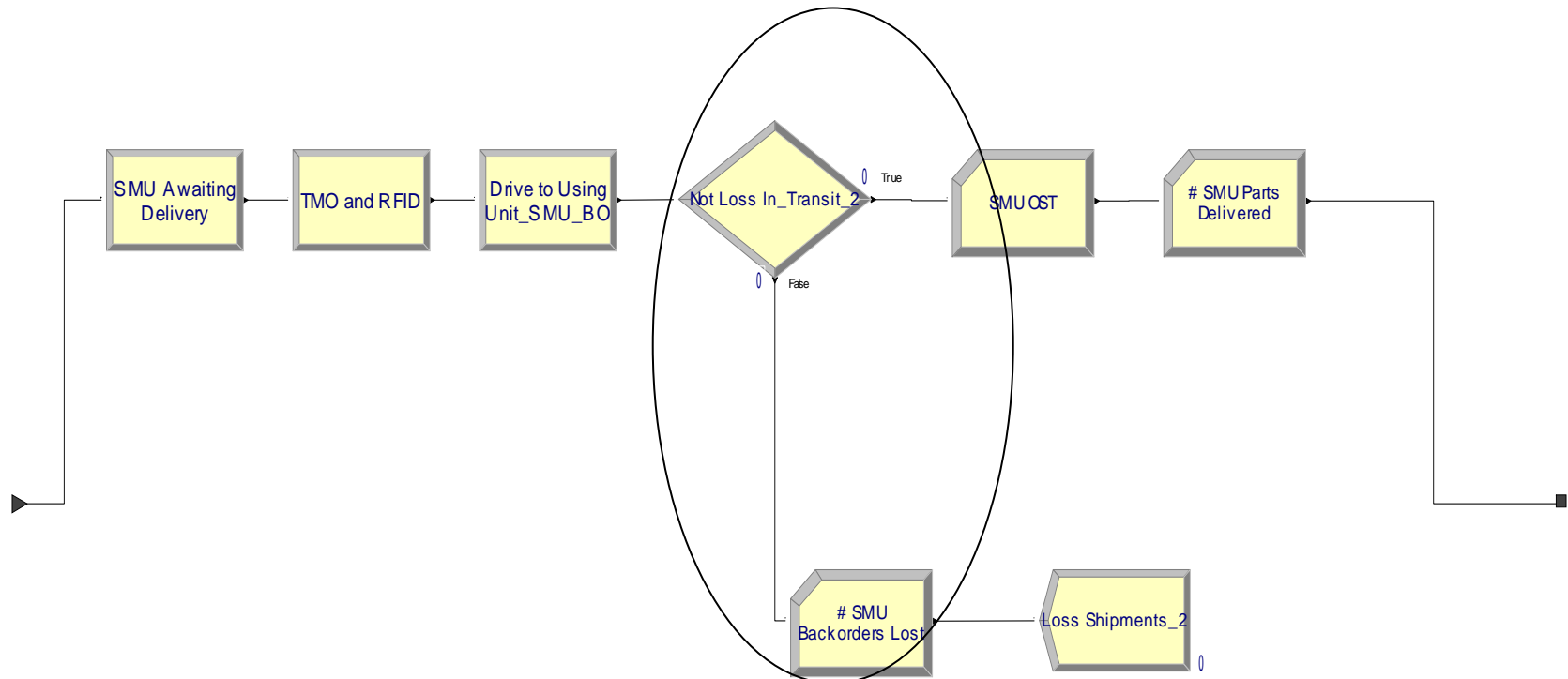

Figure 11. Modified 'Backorder by SMU' sub-model for As-Was and Real-Time scenarios

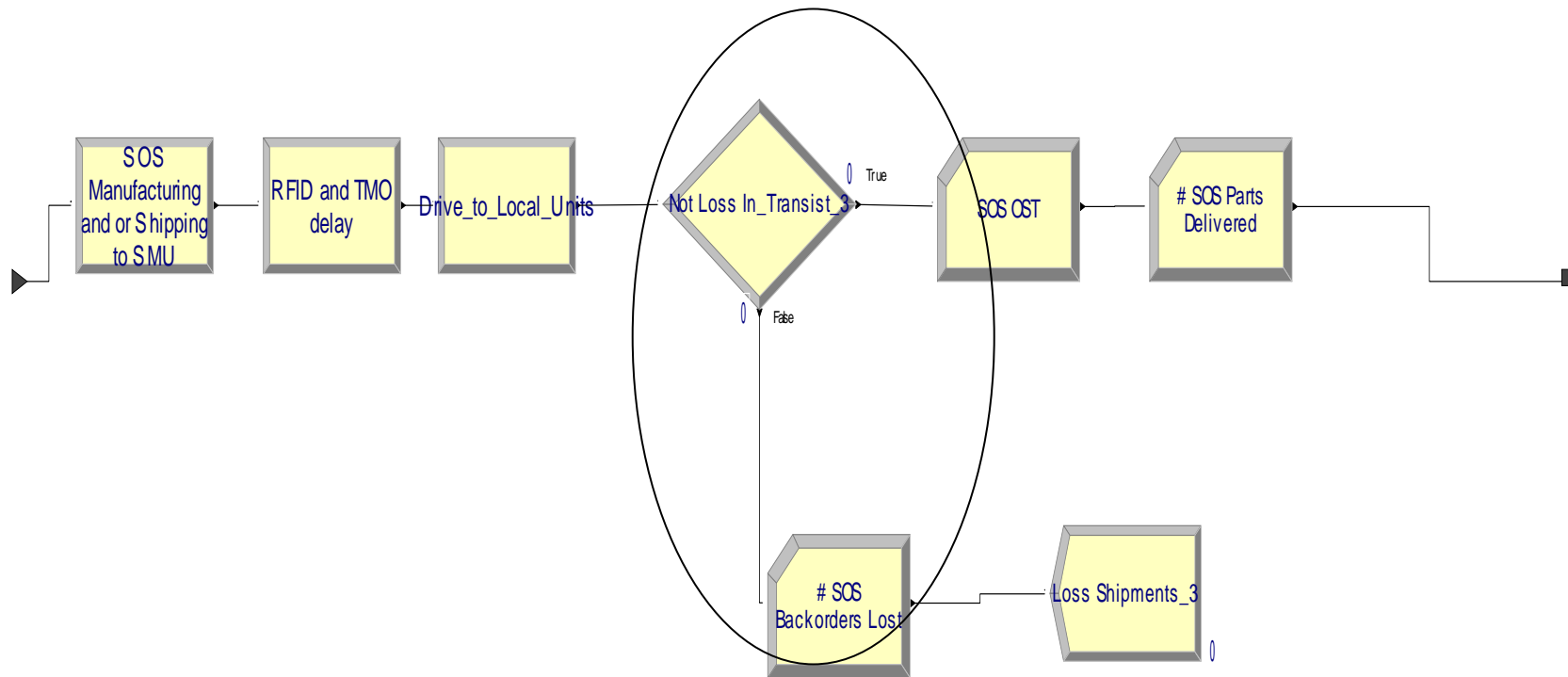

Figure 12. Modified 'Backorder by SOS' sub-model for As-Was and Real-Time scenarios

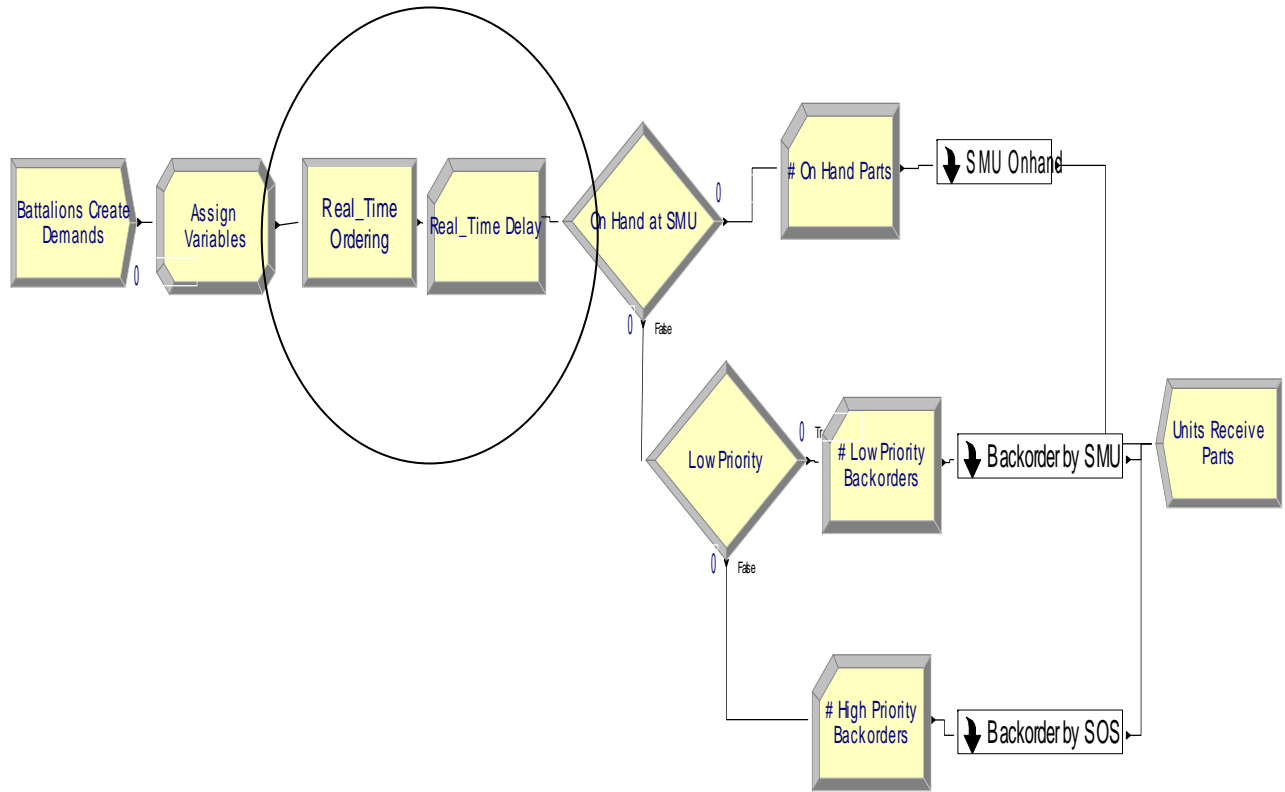

Figure 13. Real-Time and To-Be Modified Supply Process - No Batch Ordering

THIS PAGE INTENTIONALLY LEFT BLANK

V. RESULTS

A. SIMULATION RESULTS

The simulation developed by the author covered a period of 1000 days, with each day equaling 24 hours. The simulation was replicated 100 times to ensure the confidence intervals around the estimates were sufficiently small.

1. Base Case (As-Was): The Marine Corps' Supply Process Prior to ITV

Recall the Base Case (As-Was) scenario simulates the supply process without ITV. The author increased the As-Is total demands distribution (NORM[825,508]) by 32% (to NORM[1089,583]) in order to demonstrate multiple reordering. 11% of the requisitions will be lost due to lack of visibility. In order to show the added effects of a lack of ITV on the supply process the travel time from TMO to the using unit was modified from expression UNIF[2,4] to UNIF[14,16] hours. The increase in travel time is what occurs when requisitions are misrouted due to lack of ITV. See Table 2 for the results.

Demands	Variable	Result (mean, confidence interval)	Majority Of Order Ship Times(OST)
NORM[1089,583]	Requisitions Satisfied by SMU	54.66% ± 5.8%	N/A
	On Hand OST	63.32 ± 2.21 hours 2.6 days	99% were below 67 hours
	SMU OST (Low Pri)	392.66 ± 14.34 hours 16.4 days	95% were below 17 days
	SOS OST (High Pri)	1669.85 ± 69.56 hours 69.6 days	83% were below 80 days

Table 2. Base Case (As-Was) Simulation Results

The 54.66% fill rate is based upon the total demands requested versus the '# On Hand Parts Delivered.' Due to a lack of ITV the SMU's initial fill rate of 61.33% has been reduced by approximately 7%. This reduction is attributed to parts being lost en route due to a lack of visibility. The order ship times range from 2.6 days if the part is on hand to a little over 16 days if it is a low priority (SMU fills backorder) to over 69 days if it is a high priority (SOS fills backorder).

In computing the frequency value ('Majority of Order Ship Times(OST)' column in Table 2) for order ship times the author found it difficult to arrive at a frequency percentage above 90% for the high priority backorders. This is most likely due to the variance in the data collected by the author. As one can see

from Table 2, the results of the simulation returned a frequency of only 83%. Conversely the frequency percentage for the order ship times of the low priority and on hand order ship times was at least 95%.

2. Real-Time: Hypothetical Improvement Using a Real-Time Order Processing System Vice a Batch Order Processing System

In this scenario the author used the same number of demands (32% increase from NORM[825,508] to NORM[1089,583]) and increased the travel time (from UNIF[2,4] to UNIF [14,16] hours) as in the As-Was scenario. In order to simulate a real-time order process the Base Case (As-Was) scenario was modified by changing the deterministic courier delay from 10 hours to a uniform random delay of 0 to 10 hours (UNIF[0,10]). The batching of the courier was completely eliminated. The results are in Table 3.

Demands	Variable	Result (mean, confidence interval)	Majority Of Order Ship Times
NORM[1089,583]	Requisitions Satisfied by SMU	55% ± 5.7%	N/A
	On Hand OST	45.33 ± 1.58 hours 1.87 days	99% were below 48 hours
	SMU OST (Low Pri)	372.10 ± 15.51 hours 15.5 days	95% were below 16 days
	SOS OST (High Pri)	1633.30 ± 70.12 hours 68 days	84% were below 80 days

Table 3. Real-Time: As-Was Using Real-Time Vice Batch Ordering

The fill rate in this scenario increased by one percentage point over the As-Was scenario. Even though it is a small increase that increase in supply distribution can have a huge impact. The improvement of the order ship times should be noted. Now if SMU has the part on hand the order ship time is approximately 2 days vice 2.6 days in the As-Was scenario. The low priority backorder's order ship time has decreased from a little over 16 days in the As-Was scenario to 15.5 days when real-time order processing is implemented. The high priority backorder's order ship time has decreased from 69.5 days to 68 days. Although the decrease in each one the order ship times is only one day, an improvement in other areas of the supply process could potentially decrease the order ships times by much more. The frequency of order ship times value for the on hand and low priority demands show a slight decrease while the frequency percentage remains the same. For demands that are on hand in this scenario 99% of the demands will have an order ship time less than 48 hours vice less than 67 hours (As-Was). For the low priority backorders 95% of the order ships times will be less than 16 days vice less than 17 days (As-Was). The high priority backorders frequency order ship time is still less than 80 days for this scenario but the frequency percentage increased from 83% to 84%.

3. As-Is: The Current Marine Corps Supply Process with ITV

In this next scenario the author will run the simulation based on the current Marine Corps' supply process. In this scenario there should be a noticeable decrease in the multiple reorders as well as an elimination of misrouted and/or lost requisitions. Since there is no multiple reordering the original

total demand distribution was used (NORM[825,508]). Also since there is not an increase in demands all picks will arrive at TMO by 1500 thus there is no need for the 24 delay for 6.75% of the demands. The original travel time (UNIF[2,4] hours) to the using units will be used in addition to eliminating the possible misrouting and lost requisitions. See Tables 4 for the results.

Demands	Variable	Result (mean, confidence interval)	Majority Of Order Ship Times
NORM[825,508]	Requisitions Satisfied by SMU	61.7% ± 7.3%	N/A
	On Hand OST	48.42 ± 2.41 hours 2 days	99% were below 52 hours
	SMU OST (Low Pri)	371.85 ± 18.97 hours 15.5 days	94% were below 16.5 days
	SOS OST (High Pri)	1616.29 ± 84.53 hours 67.3 days	85% were below 80 days

Table 4. As-Is: The Current Marine Corps Supply Process with ITV

These results as compared to the two previous scenarios have two separate distinctions. The fill rate has improved compared to the As-Was and Real-Time scenarios by at least 6%, which is significant improvement. The on hand order ship time did increase from 1.8 days in the Real-Time scenario to 2 days in the As-Is scenario. This increase in order ship time is largely due to the batch ordering process currently being used in the As-Is scenario. The low and high priority ship times

slightly decreased in comparison to the Real-Time scenario, but not by much. The author deduces this decrease is due to less multiple reordering, decreased travel times, and no loss shipments. The high priority shipping times still have very long lead times. The author should also note that the frequency value for order ship times did improve slightly for parts on hand at the SMU as well as an increase in the frequency percentage for high priority backorders.

4. To-Be: The Marine Corps Supply Process Using a Real-time Order Processing System Vice a Batch Ordering Processing System

This last scenario will simulate the supply process with ITV and a real-time ordering process. In order to simulate a supply process with ITV and a real-time ordering system the author slightly modified the As-Is scenario by changing the courier delay from 10 hours to a uniform random delay of 0 to 10 hours (UNIF [0,10]). The author also eliminated the batching of the couriers. See Table 5 for the results.

Demands	Variable	Result (mean, confidence interval)	Majority Of Order Ship Times
NORM[1089,583]	Requisitions Satisfied by SMU	61.5 ± 7.3%	N/A
	On Hand OST	31.02 ± 1.54 hours 1.3 days	99% were below 36 hours
	SMU OST (Low Pri)	354.11 ± 18.23 hours 15.5 days	94% were below 16 days
	SOS OST (High Pri)	1609.67 ± 84.66 hours 67 days	86% were below 80 days

Table 5. To-Be: The Marine Corps Supply Process Using a Real-time Order Processing System Vice a Batch Order Processing System

Using a real-time ordering process as well as ITV the improvements in the supply process are noted by the increased fill rate from 54%(As-Was) to 61.5%, decreased order ship times from 2.6 days(As-Was) to 1.3 days (SMU has On hand), decreased order ship time from 17 days (As-Was) to 15.5 days (not on hand and low priority) and a decreased order ship time from 69 days (As-Was) to 67 days (not on hand and high priority). Although these improvements are small numbers, in supply distribution, small incremental improvements are seen as huge successes. In a combat environment having the ability to get a part to a unit a day early can have a huge impact on the success of the mission. The author has noted the improvement from the As-Was to the To-Be but it must be noted that the real-time ordering process has

better order ship times than the As-Is supply process as well. Once again the improvements might not seem that significant but for a combat unit, receiving a part in 2 days vice 3 days is critical to mission accomplished. Finally implementing a real-time ordering process in addition to ITV, 99% of the order ships times for demands that are on hand will be less than 36 hours, 95% of the order ship times for low priority backorders will be less than 16 days, and 86% of high priority backorders will be less than 80 days.

VI. CONCLUSION

A. RECOMMENDATIONS

The current Marine Corps' Supply Process is not perfect but it is a definite improvement due to the LTMITV and W2W systems. By developing the simulation the author was able to pinpoint certain opportunities for improvement in the system that need to be addressed. One opportunity for improvement is to replace the legacy batch ordering system with a real time ordering system. Another is the long order ship times for high priority backorders. A final area for potential improvement is the lack of ITV at the SOS.

One recommendation is that the Marine Corps develop a standard real-time supply system across the Marine Corps that is deployable and incorporates ITV at all levels of the supply chain to include the SOS. This system should be web-based and possess the ability to provide the user with an immediate response as to the availability of the item they have requested. This system should also provide estimated shipping dates for any items that are on hand. Due to the fact that all requisitions tie directly into the unit's funds, the system must be interoperable with the financial management system as well. One of the most important aspects of the system is that it should be deployable so the supply distributors of the Marine Corps can live by the motto of 'Train as we Fight.'

A second, simpler to implement recommendation is that the Marine Corps aggressively pursue efforts to incorporate ITV at the SOS. The added ITV at the SOS could help prevent multiple reordering, decrease any possible loss shipments from the SOS to

the SMU, and further increase the using unit's confidence in the supply system. Per the scenarios there was a noticeable improvement in the order ship times once ITV was added at the SMU level, hopefully ITV at the SOS (available to view by the using unit) will have an even greater benefit on the supply process.

B. FUTURE RESEARCH

Future research needs uncovered during the initial simulation efforts, which the author would have pursued were data available, include: conducting a field exercise test which incorporates the use a GPS system as well as nodal in a dynamic environment, determine if mesh networking is a viable solution of assisting in ITV, and the incorporation of passive RFID technology as well as active in the supply process.

The field exercise test should be conducted because we know that the supply process with ITV works in a static environment (meaning combat as well as service support units are not constantly moving in the area of operations) but what about in a dynamic environment(i.e., the first three weeks of the war during OIF I). How will this system hold up when the combat units are constantly on the move as well as the intermediate level combat service support units? Due to the three opportunities for improvement identified, operating in a dynamic environment could cause increased delays in the order ships times and possibly cause shipments to be misrouted or even worse, lost. This testing can determine where interrogators should be set up, how a handoff should be accomplished if one CSS unit is moving forward, how reliable is the GPS during combat, if ITV starts with the supplier and ends at the tactical level. The second area for possible future research involved the

use of a mesh network to implement ITV in a dynamic environment. Mesh networking could allow units to be able to communicate regardless of their location. Also each unit would have visibility of the network and know when unit is not on the network. This could be due to an equipment failure or the fact that the unit is in transit. [20] This test could also be conducted in a field exercise. Lastly the passive RFID technology can assist in inventory management as well as identifying the location of an item down to the lowest level instead of a container. Currently the location of a part is based upon how accurate the supply clerk is at loading items in the container that has the active RFID tag attached. If someone loads the wrong part into the wrong container then we have the problem of misrouting of requisitions, with ITV.

THIS PAGE INTENTIONALLY LEFT BLANK

APPENDIX A. UNIT PERFORMANCE REPORT

Excerpt from the Unit Performance Report received by the SMU. The author received 41 days of this report and pulled the total demands and total complete fills data in order to create probability distributions for the simulation. This data was provided by the SMU in Camp Pendleton.

ACTIVITY:	MMC100	GENERAL ACCOUNT PERFORMANCE REPORT	DAILY
TOTAL DEMANDS		00634	
TOTAL COMPLETE FILLS		00425	NUMBER
TOTAL PARTIAL FILLS		00007	INVENTORY GAINS (REV) 00000
% COMPLETE FILL		067.00	INVENTORY LOSS (REV) 00000
% PARTIAL FILL		001.10	VALUE INVENTORY GAINS 00040
DEMANDS FOR RO ITEMS		00436	INVENTORY LOSS 00024
COMPLETE RO FILLS		00396	REQN SUBMITTED W/FUNDS 00114
PARTIAL RO FILLS		00005	REQN SUBMITTED W/OFUNDS 00000
% COMPLETE RO FILL		095.40	CANCELS REQUESTED 00000
% PARTIAL RO FILL		001.10	CANCELS CONFIRMED 00004
B/O CANCELLED		00000	REQNS REJECTED 00008
REG. B/O REL (TOTAL)		00002	PASSED DEMANDS 00201
0 REG. B/O REL (PART)		00000	1-2DAYS
HOT ITEM B/O REL		00000	WAREHOUSE ISSUE CONFIRMS 00010
RECEIPTS FROM DUE		00253	SHIPMENT CONFIRMS 00000
RECEIPTS NOT DUE		00116	
RECEIPTS CLOSED REC		00001	2-Jan
ISSUES TO DISPOSAL		00000	RECEIPT DATE THRU PUNCH 00253
CONDITION TRANSFERS		00000	RECEIPT PUNCH THRU PROCES 00250
PURPOSE TRANSFERS		00000	RECEIPT DATE THRU PROCESS 00250
WAREHOUSE DENIALS		00002	
TOTAL REQNIN REJECT		00004	1-15DAY
REDISTRIBUTIONS		00000	NO. DAYS TO FIRST RECEIPT 00000
NUMBER BACKORDERS		00251	NO. DAYS TO ALL RECEIPT 00248
REGULAR B/O ESTAB		00011	
HOT ITEM B/O ESTAB		00048	
SERIAL NUMBER COUNTER		7702	
GENERAL ACCT FUNDS AVAILIABLE \$289,046			4.18

THIS PAGE INTENTIONALLY LEFT BLANK

APPENDIX B. DAILY TRANSACTION LISTING

Excerpt from a daily transaction listing in which the AS1 transactions were used to determine the probability distribution for the delay time it takes from a backorder to be shipped once the unit places the item on backorder. The DTL was used for low priority and high priority backorders. The priority is denoted by the first two numbers in the Priority/TCN/Status column. This data was provided by the SMU in Camp Pendleton.

ACTIVITY M28349			DAILY HISTORY	DATE:5280
DIC ¹³	SOS	NSN ¹⁴	Document Number	Priority/TCN ¹⁵ /Status
AS1	S9CS	1005007162132	M2834952177009	M2834952177003XXX5
AE1	MC1S	1005009215004	M2834952797003	13310BA02790000860
AS1	MC1	1005009215004	M2834952797003	13PDC446129280
AE1	MC1S	1005014084361	M2834952797001	13310BA02790002794
AS1	MC1	1005014084361	M2834952797001	13PDC446129280
AE1	MC1S	1005014090144	M2834952797002	13310BA02790003015
AS1	MC1	1005014090144	M2834952797002	13PDC446129280
AS2	MC1	1005014679435	M2834951296061	13PDC44453279
D6T	MC1S	1005014679435	M2834951296061	5280A1SYSTEMGEN
AS2	MC1	1010011236705	M2834952557999	05PDC44163279
D6T	MC1S	1010011236705	M2834952557999	5280A1SYSTEMGEN
AE1	MC1S	2510005356797	M2834952796001	13310BA02790025795
AE1	MC1S	2510005356797	M2834952796005	13310BA02790025795
AE1	MC1S	2510005356797	M2834952796009	13310BA02790025795
AS1	MC1	2510005356797	M2834952796001	13PDC445799280
AS1	MC1	2510005356797	M2834952796005	13PDC445799280
AS1	MC1	2510005356797	M2834952796009	13PDC445799280
AE1	MC1S	2510005909734	M2834952796002	13310BA02790012700
AE1	MC1S	2510005909734	M2834952796006	13310BB52790012700
AE1	MC1S	2510005909734	M2834952796010	13310BB52790012700
AS1	MC1	2510005909734	M2834952796002	13PDC445799280
AS2	MC1	2510006930741	M2834952447006	13PDC43953280

¹³ Document Identifier Code, abbreviation to identify the type of transaction.

¹⁴ National Stock Number, a 13-digit number used to identify an item of material in the supply distribution system.

¹⁵ Transportation Control Number, used to identify how the item will be shipped (i.e., ground, air, etc...)

THIS PAGE INTENTIONALLY LEFT BLANK

LIST OF REFERENCES

1. General Accounting Office Report No. GAO-04-305R, *Defense Logistics: Preliminary Observations on the Effectiveness of Logistics Activities During Operation Iraqi Freedom*, by Knouse, K., Russell, C., Winterlin, G., Venner, J., Nguyen, T., & Benco, N., 18 December 2003.
2. Sweeney II, Patrick J., *RFID for Dummies*, 1st ed., pp.10-45, Wiley Publishing, 2005.
3. Lahiri, S., *RFID Sourcebook*, 1st ed., pp. 1-62, IBM Press, 2006.
4. Department of Defense. (2006). *DoD Announces Radio Frequency Identification Policy*. Retrieved May 31, 2006.
5. Under Secretary of Defense. (2003). *Radio Frequency Identification Policy [Background on the Use of RFID in the DoD Supply Chain]*. Washington, DC, Retrieved May 25, 2006, from http://www.acq.osd.mil/log/rfid/Policy/RFID_Policy_Oct03.pdf
6. Woronka, Dave, "The State of the Art in Apparel." [<http://www.techexchange.com/thelibrary/rfid.html>]. June 2006.
7. Heydary, Javed, "Legal Implications of Using RFID Highlighted." [<http://www.technewsworld.com/story/40203.html>]. June 2006.
8. General Accounting Office Report No. GAO/NSIAD-92-258, *Operation Desert Storm: Lack of Accountability Over Material During Redeployment*, by Klotz, J. J., Taylor Jr., Harry E., Schmitt, D. A., Wren, J. C., & Schroder, S. L., September 1992.
9. United States Marine Corps, Combat Service Support Group-15, *Supply and Distribution: Bridging the Gap Between Warehouse and Warfighter*, pp. 1-44, 2004.

10. Interview between K. Morales, Sergeant, SMU Process Reform Center, 1st Supply Battalion, 1st MLG, Camp Pendleton, CA, and the author, 22 - 25 March 2006.
11. "AMS-TAC, Automated Manifest System, Tactical." [http://www.marcorsyscom.usmc.mil/sites/Transfdpe/AMS-TAC_Main.asp]. June 2006.
12. Interview between Fitzsimmons, 1st Lieutenant, SMU Customer Service Officer in Charge, 1st Supply Battalion, 1st MLG, Camp Pendleton, CA, and the author, 23 March 2006.
13. United States Marine Corps, Headquarters USMC, Marine Corps Order 4400.16G (w/CH 1-3), pp.1-10. 1985.
14. United States Marine Corps, Headquarters USMC, UM 4400-124, SASSY Using Unit Procedures (w/Ch4), 1984.
15. Interview between Katarzyna Ryzewska, Corporal, SMU Operations Section, 1st Supply Battalion, 1st MLG, Camp Pendleton, Ca and the author 24 March 2006.
16. Kelton, D., Sadowski, R.P., and Sturrock, D.T., Simulation With Arena, McGraw-Hill, 2004.
17. Costa, Keith J, "New Study Looks For Evidence of Network-Centric Logistics in Iraq." [http://www.oft.osd.mil/library/library_files/article_231_Inside%20The%20Pentagon.doc]. August 2006.
18. U.S. Department of Defense, United States Marine Corps, *Operation Iraqi Freedom Lesson Learned*, p.26, [<http://www.globalsecurity.org/military/ops/oif-lessons-learned.htm>]. August 2006.
19. CRTC Telecommunications Industry Data Collection, "Glossary." [<http://www.crtc.gc.ca/dcs/eng/glossary.htm>]. August 2006.
20. Akin, D. and Bardwell, J., *Certified Wireless Network Administrator: Official Study Guide*, McGraw Hill, 2005.

INITIAL DISTRIBUTION LIST

1. Defense Technical Information Center
Ft. Belvoir, Virginia
2. Dudley Knox Library
Naval Postgraduate School
Monterey, California
3. D. C. Boger
Naval Postgraduate School
Monterey, California
4. Dr. Kenneth Doerr
Naval Postgraduate School
Monterey, California
5. Glen Cook
Naval Postgraduate School
Monterey, California
6. Commanding Officer
1st Supply Bn, 1st CLR, 1st MLC
Camp Pendleton, California
7. Company Commander, SMU
1st Supply Bn, 1st CLR, 1st MLC
Camp Pendleton, California
8. Jerry Rodgers
PM J-AIT Support Contractor (INNOLOG)
Newington, Virginia
9. Marine Corp Representative
Naval Postgraduate School
Monterey, California
10. Director, Training and Education, MCCDC, Code C46
Quantico, Virginia
11. Director, Marine Corps Research Center, MCCDC, Code C40RC
Quantico, Virginia

12. Marine Corps Tactical Systems Support Activity(Attn:
Operations Officer)
Camp Pendleton, California