



**Calhoun: The NPS Institutional Archive**  
**DSpace Repository**

---

Theses and Dissertations

1. Thesis and Dissertation Collection, all items

---

1989

**NEC, NECGS, and MININEC numerical models  
of LF top-hat monopole antennas**

**Padmosutoyo, Slamet Suharsa**

Monterey, California. Naval Postgraduate School

---

<https://hdl.handle.net/10945/26100>

---

*Downloaded from NPS Archive: Calhoun*



Calhoun is the Naval Postgraduate School's public access digital repository for research materials and institutional publications created by the NPS community. Calhoun is named for Professor of Mathematics Guy K. Calhoun, NPS's first appointed -- and published -- scholarly author.

**Dudley Knox Library / Naval Postgraduate School**  
**411 Dyer Road / 1 University Circle**  
**Monterey, California USA 93943**

<http://www.nps.edu/library>









# NAVAL POSTGRADUATE SCHOOL

## Monterey, California



# THESIS

P11624

NEC, NECGS, AND MININEC NUMERICAL  
MODELS OF  
LF TOP-HAT MONOPOLE ANTENNAS

by

Slamet Suharsa Padmosutoyo

March 1989

Advisor:  
Co-Advisor

Richard W. Adler  
James K. Breakall

Approved for public release; distribution is unlimited

T242221



Unclassified

Security classification of this page

REPORT DOCUMENTATION PAGE

Report Security Classification Unclassified		1b Restrictive Markings	
Security Classification Authority		3 Distribution Availability of Report	
Declassification Downgrading Schedule		Approved for public release; distribution is unlimited.	
Performing Organization Report Number(s)		5 Monitoring Organization Report Number(s)	
Name of Performing Organization Naval Postgraduate School	6b Office Symbol (if applicable) 32	7a Name of Monitoring Organization Naval Postgraduate School	
Address (city, state, and ZIP code) Monterey, CA 93943-5000		7b Address (city, state, and ZIP code) Monterey, CA 93943-5000	
Name of Funding Sponsoring Organization	8b Office Symbol (if applicable)	9 Procurement Instrument Identification Number	
Address (city, state, and ZIP code)		10 Source of Funding Numbers	
		Program Element No	Project No
		Task No	Work Unit Accession No

Title (include security classification) NEC, NECGS, AND MININEC NUMERICAL MODELS OF LF TOP-HAT MONOPOLE ANTENNAS

Personal Author(s) Slamet Suharsa Padmosutoyo

Type of Report Master's Thesis	13b Time Covered From To	14 Date of Report (year, month, day) March 1989	15 Page Count 60
-----------------------------------	-----------------------------	--	---------------------

Supplementary Notation The views expressed in this thesis are those of the author and do not reflect the official policy or position of the Department of Defense or the U.S. Government.

Cosati Codes			18 Subject Terms (continue on reverse if necessary and identify by block number) thesis, antenna, top-hat monopole.
Block	Group	Subgroup	

Abstract (continue on reverse if necessary and identify by block number)

The US Navy needs to increase the power handling capability of its current VLF and LF top-hat monopole antennas. This is most efficiently studied via numerical analysis of candidate antennas. Previous computer models based on the Numerical Electromagnetics Code (NEC-3) were shown to be unacceptable. The reasons for the inaccuracies were discovered to be NEC's inability to accurately model the effects of step changes of radius on adjacent portions of the structure. This thesis investigates two additional numerical models. The first uses the MININEC SYSTEM which has been shown to be accurate for stepped-radius antennas, and the second approximates a top-hat monopole antenna by a wire-cage structure. The latter employs NECGS, a special version of NEC-3 which efficiently uses radial symmetry. The performance parameters of interest which were calculated are static capacitance, resonant frequency, effective height, and radiation resistance. The results of these new models are compared to scale-model measurements and to the numerical results of the earlier NEC-3 model. The MININEC SYSTEM produces acceptable values but is limited in the number of unknowns used to describe the model. NECGS results indicate that an acceptable wire-cage equivalency to a top-hat monopole may not exist.

Distribution Availability of Abstract Unclassified unlimited <input type="checkbox"/> same as report <input type="checkbox"/> DTIC users	21 Abstract Security Classification Unclassified	
Name of Responsible Individual Richard W. Adler	22b Telephone (include Area code) (408) 646-2352	22c Office Symbol 62Ab



Approved for public release; distribution is unlimited.

NEC, NECGS, and MININEC Numerical Models  
of  
LF Top-hat Monopole Antennas

by

Slamet Suharsa Padmosutoyo  
Major, Indonesian Air Force  
I.R.E., University of Indonesia, 1980 Jakarta  
B.S., Indonesian Air Force Academy, 1972 Yogyakarta

Submitted in partial fulfillment of the  
requirements for the degree of

MASTER OF SCIENCE IN ENGINEERING SCIENCE

from the

NAVAL POSTGRADUATE SCHOOL  
March 1989

---

Gordon E. Schacher,  
Dean of Science and Engineering

## ABSTRACT

The US Navy needs to increase the power handling capability of its current VLF and LF top-hat monopole antennas. This is most efficiently studied via numerical analysis of candidate antennas. Previous computer models based on the Numerical Electromagnetics Code (NEC-3) were shown to be unacceptable. The reasons for the inaccuracies were discovered to be NEC's inability to accurately model the effects of step changes of radius on adjacent portions of the structure.

This thesis investigates two additional numerical models. The first uses the MININEC SYSTEM which has been shown to be accurate for stepped-radius antennas, and the second approximates a top-hat monopole antenna by a wire-cage structure. The latter employs NECGS, a special version of NEC-3 which efficiently uses radial symmetry. The performance parameters of interest which were calculated are static capacitance, resonant frequency, effective height, and radiation resistance. The results of these new models are compared to scale-model measurements and to the numerical results of the earlier NEC-3 study. The MININEC SYSTEM produces acceptable values but is limited in the number of unknowns used to describe the model. NECGS results indicate that an acceptable wire-cage equivalency to a top-hat monopole may not exist.

172015  
P116-4  
C.1

## TABLE OF CONTENTS

I. INTRODUCTION .....	1
A. BACKGROUND .....	1
B. SCALE-MODEL MEASUREMENTS .....	1
C. NEC-3 NUMERICAL RESULTS .....	3
D. SCOPE AND LIMITATIONS .....	4
II. ANTENNA COMPUTER MODELS .....	5
A. GENERAL .....	5
B. THE CHARACTERISTICS OF VLF AND LF ANTENNAS .....	5
C. NECGS ANTENNA COMPUTER MODELS .....	7
1. NECGS Reference Monopole .....	7
2. NECGS Top-hat Antenna .....	7
D. MININEC ANTENNA COMPUTER MODELS .....	9
1. MININEC Reference Monopole .....	9
2. MININEC Top-hat Antenna .....	9
E. ELECTRICAL PROPERTIES DETERMINED VIA COMPUTER MOD- ELING .....	9
1. Static Capacitance .....	9
2. Resonant Frequency .....	11
3. The Effective Height .....	11
4. Radiation Resistance .....	11
III. COMPUTER MODEL RESULTS .....	12
A. REFERENCE MONOPOLE RESULTS .....	12
B. TOP-HAT ANTENNA RESULTS .....	13
IV. CONCLUSIONS AND RECOMMENDATIONS .....	32
APPENDIX A. THE NUMERICAL ELECTROMAGNETICS CODE (NEC) ..	33

APPENDIX B. PERFORMANCE DATA FOR 12-WIRE TOP-HAT ANTEN-	
NAS .....	35
LIST OF REFERENCES .....	48
INITIAL DISTRIBUTION LIST .....	49

## LIST OF TABLES

Table 1.	PERCENTAGE DIFFERENCE OF CALCULATED REFERENCE MONOPOLE PROPERTIES COMPARED WITH MEASUREMENTS.	12
Table 2.	MAXIMUM PERCENTAGE DIFFERENCE OF CALCULATED 6-WIRE TOP-HAT NORMALIZED ANTENNA PROPERTIES COMPARED WITH MEASUREMENTS .....	17
Table 3.	OPTIMUM VALUES OF TOP-HAT WIRE LENGTH ( $H_1/H$ ) OF A 6-WIRE TOP-HAT ANTENNA .....	18
Table 4.	COMPARISON OF PERFORMANCE PARAMETER CHANGE WHEN INCREASING TOP-HAT RADIALS FROM 6 TO 12 WIRES.	31
Table 5.	MAXIMUM PERCENTAGE DIFFERENCE OF CALCULATED 12-WIRE TOP-HAT NORMALIZED ANTENNA PROPERTIES COMPARED WITH MEASUREMENTS .....	35
Table 6.	OPTIMUM VALUES OF TOP-HAT WIRE LENGTH ( $H_1/H$ ) OF A 12-WIRE TOP-HAT ANTENNA .....	35

## LIST OF FIGURES

Figure 1.	Monopole and Top-hat Monopole Antenna Models of Devaney's Report.	2
Figure 2.	Monopole and Top-hat Antennas for NECGS computer models. . . . .	8
Figure 3.	Monopole and Top-hat Antennas for MININEC computer models. . . .	10
Figure 4.	Variation of Static Capacitance of Reference Monopole Antenna as a Function of Antenna Height. . . . .	14
Figure 5.	Variation of Resonant Frequency of Reference Monopole Antenna as a Function of Antenna Height. . . . .	15
Figure 6.	Variation of Effective Height of Reference Monopole Antenna as a Function of Antenna Height. . . . .	16
Figure 7.	Variation of Radiation Resistance of Reference Monopole Antenna as a Function of Antenna Height. . . . .	17
Figure 8.	Normalized Static Capacitance of Top-hat Antenna with Radials, $N = 6$ , NEC versus Devaney. . . . .	19
Figure 9.	Normalized Static Capacitance of Top-hat Antenna with Radials, $N = 6$ , NECGS versus Devaney. . . . .	20
Figure 10.	Normalized Static Capacitance of Top-hat Antenna with Radials, $N = 6$ , MININEC versus Devaney. . . . .	21
Figure 11.	Normalized Resonant Frequency of Top-hat Antenna with Radials, $N = 6$ , NEC versus Devaney. . . . .	22
Figure 12.	Normalized Resonant Frequency of Top-hat Antenna with Radials, $N = 6$ , NECGS versus Devaney. . . . .	23
Figure 13.	Normalized Resonant Frequency of Top-hat Antenna with Radials, $N = 6$ , MININEC versus Devaney. . . . .	24
Figure 14.	Normalized Effective Height of Top-hat Antenna with Radials, $N = 6$ , NEC versus Devaney. . . . .	25
Figure 15.	Normalized Effective Height of Top-hat Antenna with Radials, $N = 6$ , NECGS versus Devaney. . . . .	26
Figure 16.	Normalized Effective Height of Top-hat Antenna with Radials, $N = 6$ , MININEC versus Devaney. . . . .	27
Figure 17.	Normalized Radiation Resistance of Top-hat Antenna with Radials, $N = 6$ , NEC versus Devaney. . . . .	28

Figure 18. Normalized Radiation Resistance of Top-hat Antenna with Radials, N = 6, NECGS versus Devaney. . . . .	29
Figure 19. Normalized Radiation Resistance of Top-hat Antenna with Radials, N = 6, MININEC versus Devaney. . . . .	30
Figure 20. Normalized Static Capacitance of Top-hat Antenna with Radials, N = 12, NEC versus Devaney. . . . .	36
Figure 21. Normalized Static Capacitance of Top-hat Antenna with Radials, N = 12, NECGS versus Devaney. . . . .	37
Figure 22. Normalized Static Capacitance of Top-hat Antenna with Radials, N = 12, MININEC versus Devaney. . . . .	38
Figure 23. Normalized Resonant Frequency of Top-hat Antenna with Radials, N = 12, NEC versus Devaney. . . . .	39
Figure 24. Normalized Resonant Frequency of Top-hat Antenna with Radials, N = 12, NECGS versus Devaney. . . . .	40
Figure 25. Normalized Resonant Frequency of Top-hat Antenna with Radials, N = 12, MININEC versus Devaney. . . . .	41
Figure 26. Normalized Effective Height of Top-hat Antenna with Radials, N = 12, NEC versus Devaney. . . . .	42
Figure 27. Normalized Effective Height of Top-hat Antenna with Radials, N = 12, NECGS versus Devaney. . . . .	43
Figure 28. Normalized Effective Height of Top-hat Antenna with Radials, N = 12, MININEC versus Devaney. . . . .	44
Figure 29. Normalized Radiation Resistance of Top-hat Antenna with Radials, N = 12, NEC versus Devaney. . . . .	45
Figure 30. Normalized Radiation Resistance of Top-hat Antenna with Radials, N = 12, NECGS versus Devaney. . . . .	46
Figure 31. Normalized Radiation Resistance of Top-hat Antenna with Radials, N = 12, MININEC versus Devaney. . . . .	47

## I. INTRODUCTION

### A. BACKGROUND

Very Low Frequency (VLF), Low Frequency (LF), and Medium Frequency (MF) antennas operate between 10 kHz and 3 MHz, where the wavelength ( $\lambda$ ) is considered to be large (30 km to 100 m, respectively). Communications systems in these bands therefore use large antennas which are difficult and expensive to construct.

Using the linearity property of Maxwell's equations, scale models of antennas of reasonable size can be constructed. An electromagnetic structure with properties at frequency  $f$  will have identical properties at a frequency  $nf$ , provided all linear dimensions are scaled by  $1/n$ , and conductivity is scaled by  $n$  without changing the dielectric constant and permeability. The models of the antennas in this study are all electrically short, the current distribution is linear, and the radiation resistance is low. Therefore losses consume a large percentage of the input power and the input reactance ( $-jX_c$ ) is large. Top-hats placed on the antennas produce more uniform current, and increase radiation resistance and radiation efficiency [Ref. 1].

Design information for Navy top-hat VLF and LF antennas has often been based upon an NELC development report on Low Frequency Top-loaded Antennas by Devaney, et al. [Ref. 2]. An M.S. thesis from the Naval Postgraduate School (NPS) [Ref. 3], details an attempt to numerically model top-hat antennas via NEC-3.

### B. SCALE-MODEL MEASUREMENTS

The parameters of the antenna models which were used for measurements in Devaney's report [Ref. 2] are:

- The height ( $H$ ) of the test antenna tower model was 1/100 of the full scale height, 630 feet.
- The ratio,  $H/D$ , with  $D$  the outside diameters is 200.
- The frequency of operation, 5 MHz, corresponds to a full scale frequency of 50 kHz.
- The top-hat (top-loaded) radials are less than  $\lambda/8$ , see Figure 1, [Ref. 2: p. 6].

The models were constructed with the following features:

- The height ( $H$ ) of the tower was 76 inches.
- The outside diameter of the tower ( $D$ ) was 0.38 inches, scaled from 3.15 feet.



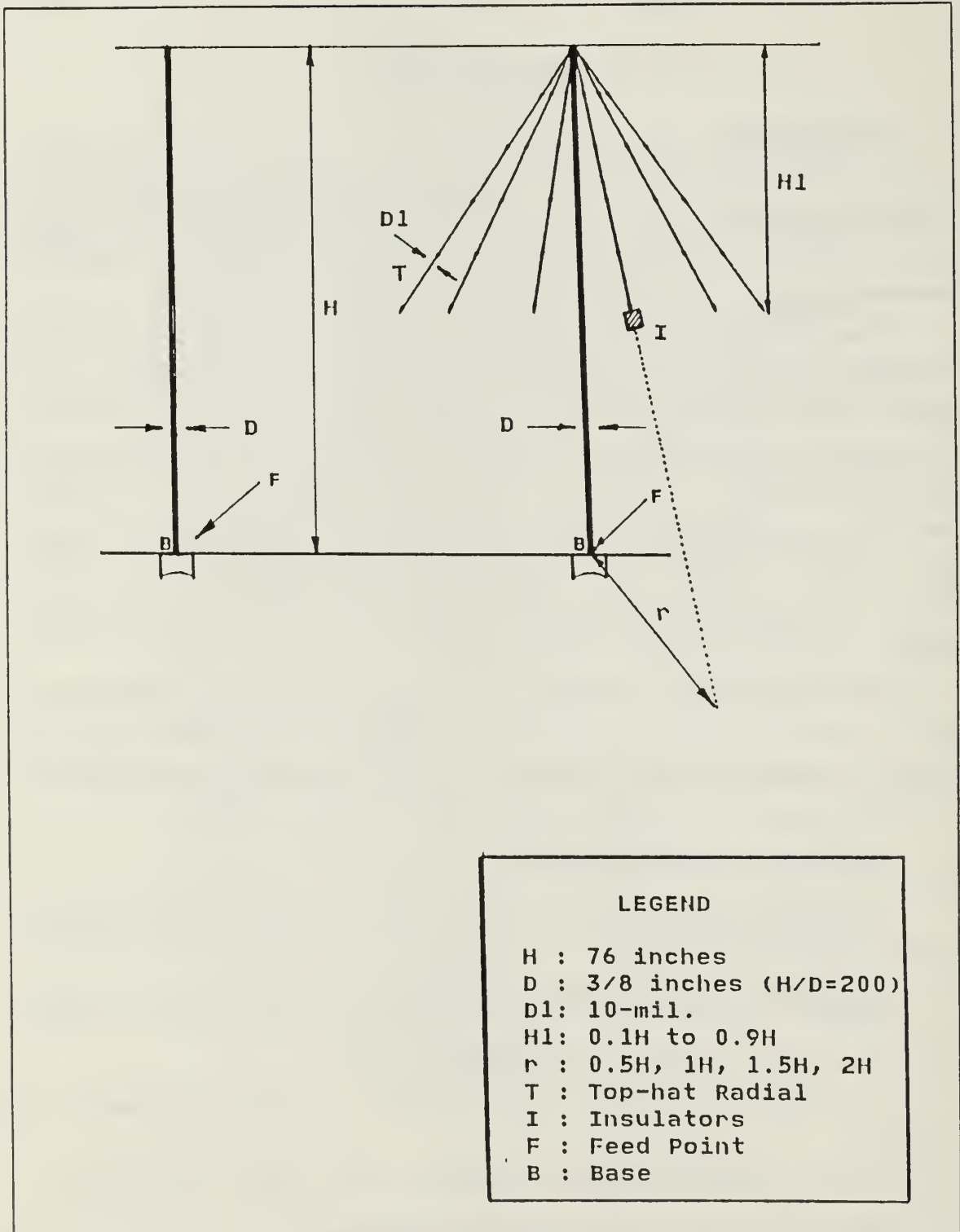

Figure 1. Monopole and Top-hat Monopole Antenna Models of Devaney's Report.

- The top-hat wires were 10 mil, # 30 soft-drawn copper, and constructed without sag.

The electrical properties such as shunt capacitance, resonant frequency, and effective height were then measured for the test models. Devaney's report covered two types of antennas.

Reference monopole: A monopole antenna with the same dimensions as above but without top-hat radials was used as a reference. The value of the tower height (H) was varied in 100 foot steps from 300 feet to 1000 feet (the model was scaled at 100:1). The operating frequencies of the full-size antennas were 50, 70.7, 100, and 150 kHz.

The radiation resistance in ohms was calculated by Devaney as:

$$R_r = 160\pi^2 \left( \frac{h_e}{\lambda} \right)^2, \quad (1)$$

where  $h_e$  is effective height in meters and  $\lambda$  is free space wavelength in meters.

Top-hat (Top-loaded) Monopole: A top-hat monopole antenna with parameters as mentioned above used six, twelve, and twenty four top-hat wires. The projection of the active portion of the tower height H was labeled H1, and was varied in steps of 0.1H from 0.1H to 0.9H. The projection of the active portion of top-hat wires,  $r$ , onto the ground was varied in steps of 0.5H from 0.5H to 2H.

Normalized values were used by Devaney as design values. For example, the normalized radiation resistance is:

$$R_r' = \left( \frac{h_e}{h_{e0}} \right)^2, \quad (2)$$

where  $h_e$  is the effective height of top-hat antenna and  $h_{e0}$  is effective height of the reference monopole.

### C. NEC-3 NUMERICAL RESULTS

In [Ref. 3], the antenna dimensions and modeling parameters matched those of the measurements, except that the value of the tower height (H) was 630 feet, the tower diameter (D) was 3.15 feet (which was  $H/D = 200$ ), and the diameter of the top-hat radials was the same as the diameter of the monopole antenna.

The electrical properties calculated using the NEC-3 model were substantially different than the measured values. This was due to the lack of accounting for the effects

of the large radius difference at the top of the monopole where the thin top-hat wires connected to the fat tower.

#### **D. SCOPE AND LIMITATIONS**

In this study, the effects of conductor radius changes at the top of the antenna are included via the use of the MININEC SYSTEM, a BASIC program version of NEC, designed for PC use. The MININEC SYSTEM is limited to 50 numerical samples by the 64 k program size limit imposed by BASIC.

The radial symmetry of the top-hat monopole structure suggested that a wire-cage equivalent structure might provide relief from NEC-3's radius-change limitation and MININEC's size of structure limit. NECGS was chosen as a very efficient and powerful tool to investigate a low-frequency cage equivalent of a VLF monopole. (Several previous studies demonstrated that an equivalent cage of thin wires could provide similar scattering characteristics to those of a "fat" cylinder). A six and a twelve wire cage was chosen for convenience.

## II. ANTENNA COMPUTER MODELS

### A. GENERAL

Numerical electromagnetic modeling of antennas is based on the numerical solution of integral equations for currents induced on arbitrary structures by sources or incident fields. The arbitrary structure can include either wires or closed surface metal structures and can be modeled over a ground plane that may be either a perfect or an imperfect conductor. Excitation may be via an applied voltage source or incident plane wave. The programs can produce outputs such as induced currents and charges, near or far zone electric fields ( $E$ ) or magnetic fields ( $H$ ), impedance or admittance, gain, and radiated fields for plotting radiation patterns.

The specific programs NEC, NECGS, and MININEC are described as follows:

- Numerical Electromagnetics Code (NEC) is an advanced version of the Antenna Modeling Program. A brief description of NEC is presented in Appendix A. The NEC program usually requires access to large mainframe computer systems.
- Numerical Electromagnetics Code-Ground Screen (NECGS) is a special purpose version of NEC-3 for limited applications. It is very easy to use, runs quickly, and is good for vertical monopole antennas with uniform radial wires and a ground screen. The radial wires can include top hat wires and other conductors but must lie in the X-Z plane, rotated about the Z axis [Ref. 4: p. 180].
- Mini-Numerical Electromagnetics Code (MININEC) is a small version of NEC for analyzing antenna problems of limited size and makes use of BASIC language compatible with most popular microcomputers [Ref. 5].

This chapter also presents characteristics of VLF and LF monopoles and top-hat antennas. It includes the design of computer models of full-scale monopoles and top-hat monopole antennas. Both models are exercised over perfect ground in NECGS and MININEC.

### B. THE CHARACTERISTICS OF VLF AND LF ANTENNAS

The wavelength of VLF and LF (100 km to 1 km) determines that any reasonable distance from the base of the antenna to the end of a top-hat radial or the height of the antenna will be "electrically short". In this case a series RLC circuit will represent the input impedance where the resistance  $R$  quadratically varies with frequency, while the inductance  $L$  and the capacitance  $C$  do not change substantially. Thus these antennas have a high  $Q$  (ratio of antenna capacitive reactance to radiation resistance). The value of  $Q$  is:

$$Q = \frac{f_o}{BW} = \frac{1}{2\pi f_o C_A (R_r + R_l)} \quad (3)$$

where  $f_o$  is the operating frequency, BW is the bandwidth,  $C_A$  is the capacitance,  $R_r$  is the radiation resistance, and  $R_l$  is the total heat loss resistance.  $R_r$  and  $R_l$  are the main part of the antenna input resistance ( $R_m$ ). In this application an antenna is usually energized by a transmitter through a single tuned electrical network [Ref. 3].

The radiation efficiency is:

$$\eta = \frac{R_r}{R} \quad (4)$$

where

$$R = R_r + R_l = R_r + R_c + R_d + R_g \quad (5)$$

and  $R_r$  is the radiation resistance,  $R_l$  is the total heat loss resistance,  $R_c$  is the copper loss resistance,  $R_d$  is the equivalent series dielectric resistance, and  $R_g$  is the ground loss resistance.

The input reactance  $X_a$  in ohms is:

$$X_a = -Z_o \cot \frac{2\pi l}{\lambda} \quad (6)$$

where  $Z_o$  is the characteristic impedance of the antenna,  $l$  is the length of an equivalent uniform transmission line, and  $\lambda$  is the wavelength [Ref. 6].

For this case the characteristic impedance of the cylindrical radiator antenna is:

$$Z_o = 60 \left[ \ln \left( \frac{H}{D} \right) - 1 \right] \quad (7)$$

where H is the height and D the diameter of the cylinder. The radiation resistance  $R_r$  in ohms of any small grounded antenna is related to the effective height [Ref. 2, Ref. 4] as:

$$R_r = 160\pi^2 \left( \frac{h_e}{\lambda} \right)^2 \quad (8)$$

where  $h_e$  is effective height and  $\lambda$  is wavelength in the same units.

According to the characteristic impedance of a short vertical antenna of Equation 7, the capacitance to ground  $C_o$  in farads is:

$$C_a = \frac{2\pi\epsilon_v H}{\ln\left(\frac{H}{D}\right) - 1} \quad (9)$$

where  $\epsilon_v$  is the absolute dielectric constant  $\simeq (1/36\pi)10^{-9}$  farads meter for free space, H is the tower height, and D is the diameter in meters.

Devaney measured the effective height at 5 MHz using the substitution method and extrapolated the resistance by the resistance method, Equation 8. In general, the effective height of a short monopole antenna [Ref. 7, Ref. 3] is:

$$h_e = \frac{V_o}{E} \quad (10)$$

where  $V_o$  is the open circuit terminal voltage, and E is the field strength at the antenna.

### C. NECGS ANTENNA COMPUTER MODELS

Two antenna structures are modeled using NECGS:

#### 1. NECGS Reference Monopole

The reference monopole antenna was constructed from one vertical wire in the X-Z plane rotated about the Z axis 6 or 12 times forming a "wire cage" shown in Figure 2a.

This antenna is used to normalize data obtained for the top-hat monopoles. The parameters of this antenna are equivalent to those of the NEC study:

- The tower height (H) varied in 100 foot steps from 300 feet to 1000 feet.
- The diameter of the cage wire (D1) was 0.08366 feet (0.0255 meter), the same as the diameter of the full size top-hat monopole radial.
- The diameter of the "wire-cage" (the antenna tower) was equal to  $D = H / 200$ .
- The frequencies were 50, 100, and 150 kHz.

#### 2. NECGS Top-hat Antenna

The top-hat monopole antenna was constructed of two wires forming one vertical wire at the X plane with the other wire tilting down from its top. These wires were rotated about the Z axis 6 and 12 times forming a "wire-cage" with a top-hat as shown in Figure 2b. The dimensions of this antenna were:

- Tower height (H) was 630 feet.
- The diameter of the cage wire (D1) was the same as of the top-hat radial: 0.08366 feet.
- The diameter of the tower (D) was 3.15 feet, which was equivalent to  $H / D = 200$ .

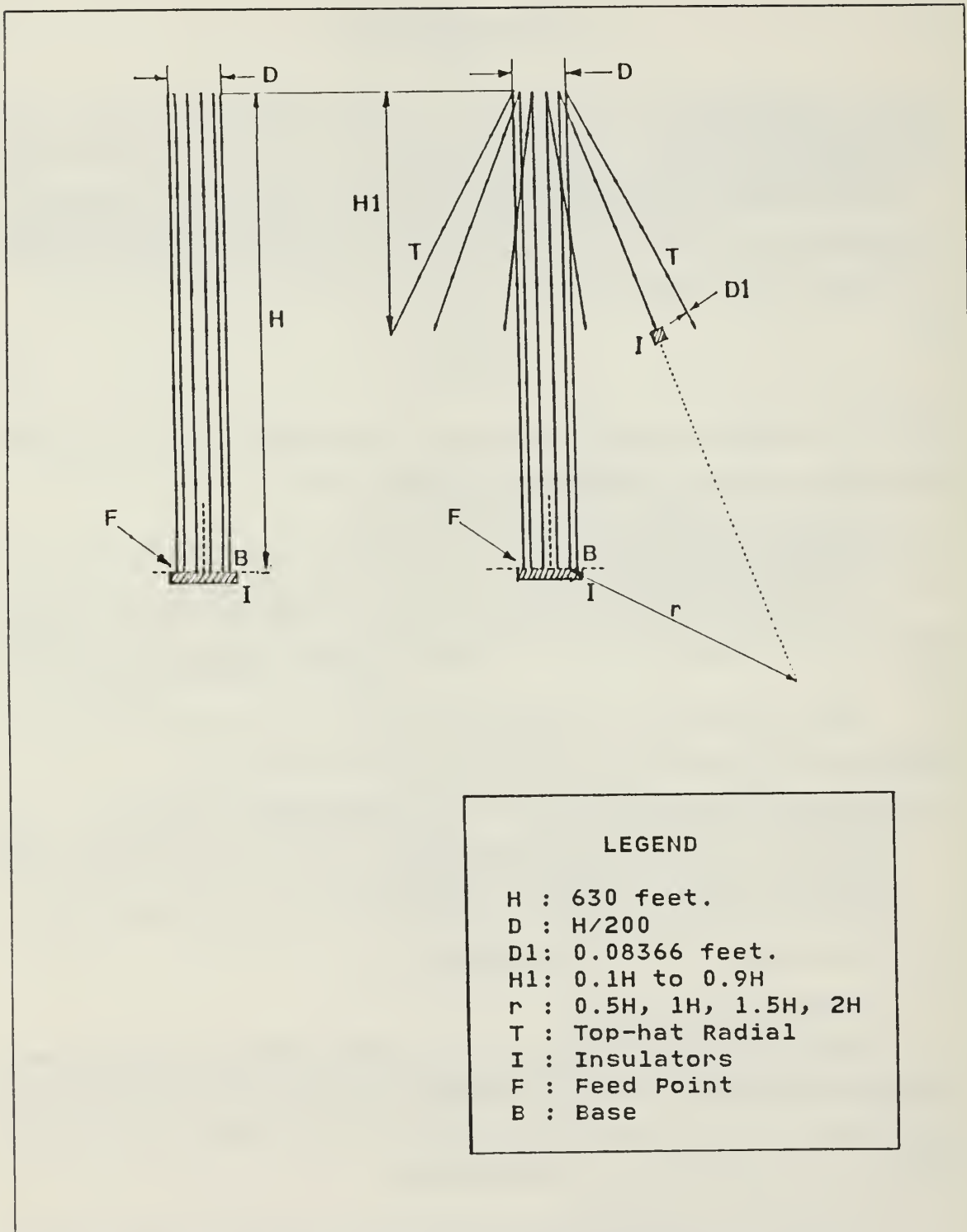

Figure 2. Monopole and Top-hat Antennas for NECGS computer models.

- The frequency was 50 kHz.
- The number of top-hat radials was 6 and 12.
- The projection of the top-hat radial is  $H1$  and is on the Z axis varying, in steps of 0.1H from 0.1H to 0.9H.
- The projection of the top-hat radial,  $r$ , onto the ground was varied in steps of 0.1H from 0.5H to 2H.

#### D. MININEC ANTENNA COMPUTER MODELS

The dimensions and details of the MININEC reference and top-hat antenna models follow:

##### 1. MININEC Reference Monopole

The reference monopole antenna was constructed of one vertical wire on the Z axis shown in Figure 3a. The dimensions of the system were as follows:

- The tower height ( $H$ ) was varied in 100 foot steps from 300 feet to 1000 feet.
- The height-to-diameter ratio of the "cylinder" (the antenna tower) was equal to 200.
- The frequencies of the antenna were 50, 100, and 150 kHz.

##### 2. MININEC Top-hat Antenna

The top-hat monopole antenna was constructed of one vertical wire (the tower of the antenna) and 6 or 12 wires tilting down around the top of the tower antenna shown in Figure 3b. The parameters for this antenna were:

- The tower height ( $H$ ) was 630 feet.
- The diameter of the antenna tower ( $D$ ) was 3.15 feet.
- The diameter of the top-hat radials ( $D1$ ) was 0.08366 feet.
- The frequency was 50 kHz.
- The number of top-hat radials was 6 and 12.
- The projection of the top-hat radial,  $H1$ , on the Z axis varied in steps of 0.1H from 0.1H to 0.9H.
- The projection of the top-hat radial,  $r$ , onto the ground was varied in steps of 0.5H from 0.5H to 2H.

#### E. ELECTRICAL PROPERTIES DETERMINED VIA COMPUTER MODELING

##### 1. Static Capacitance

The static capacitance value is the "low frequency" (D.C.) value and was found by lowering the frequency until the capacitance becomes constant. This usually happened at about 0.1 kHz for this study.



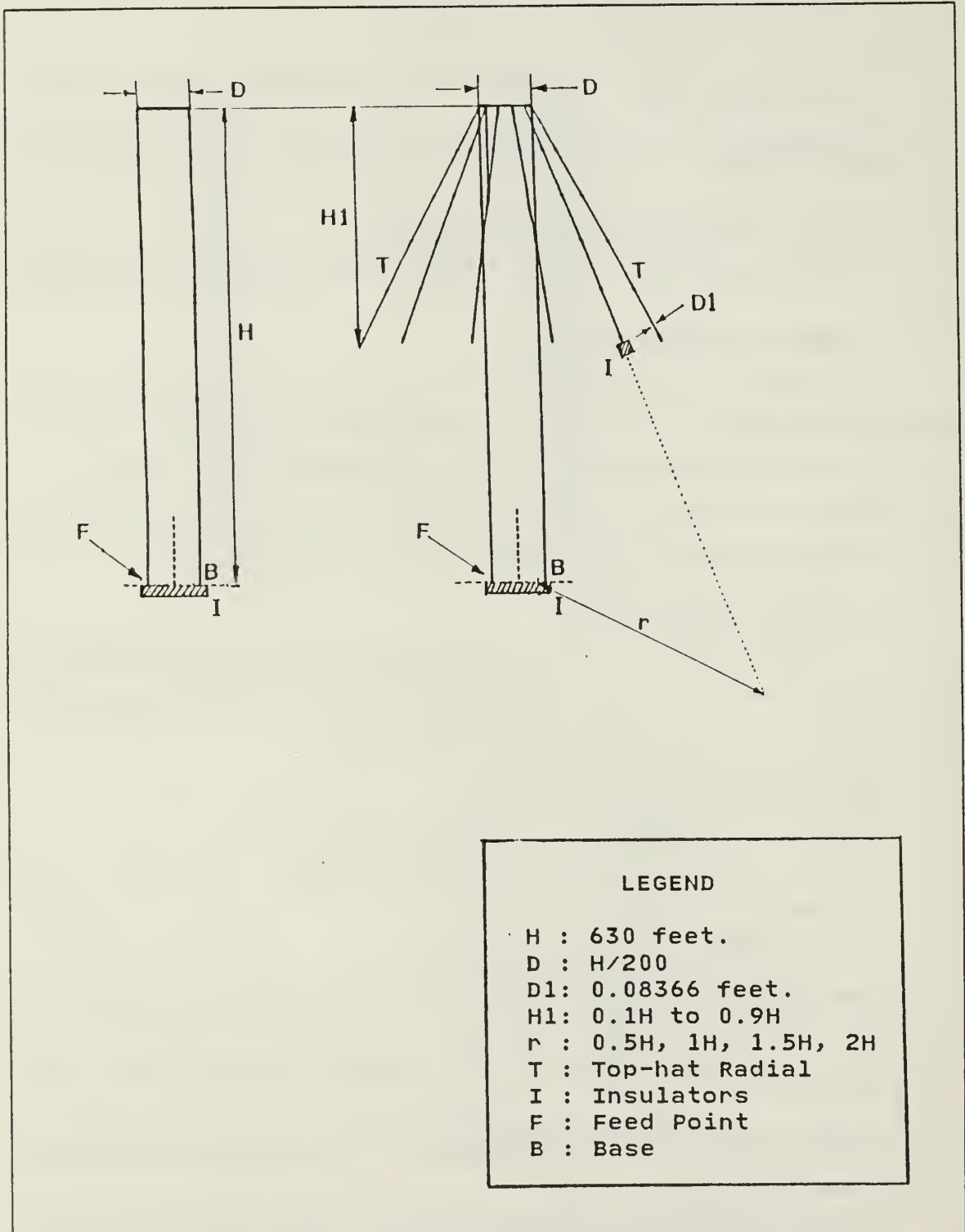

Figure 3. Monopole and Top-hat Antennas for MININEC computer models.

## **2. Resonant Frequency**

The resonant frequency is the frequency where the antenna terminal reactance becomes zero.

## **3. The Effective Height**

The effective height as obtained from Equation 10 is calculated by multiplying the short circuit current by the base impedance, giving the open-circuit voltage for a 1 volt per meter incident electric field (E).

## **4. Radiation Resistance**

Radiation resistance in this study is equal to the base resistance, and is computed for the reference monopole antenna at 50, 100, and 150 kHz, while for the top-hat monopole antenna it is computed only at 50 kHz.

### III. COMPUTER MODEL RESULTS

This chapter presents the results of the reference monopole and top-hat antenna study consisting of curves of electrical properties. These curves contain values of static capacitance, resonant frequency, effective height, and radiation resistance. For the reference monopole, values from NEC, NECGS, and MININEC are compared to measurements. The electrical properties for the top-hat antenna are shown as ratios to the measured reference monopole results.

#### A. REFERENCE MONOPOLE RESULTS

The curves of electrical properties for the reference monopole are plotted versus antenna height in Figures 4 through 7 for 50, 100, and 150 kHz.

Table 1. PERCENTAGE DIFFERENCE OF CALCULATED REFERENCE MONOPOLE PROPERTIES COMPARED WITH MEASUREMENTS.

	NEC	NECGS	MININEC
Static Capacitance	3.4 % to 4.4 % low	2.9 % low	3.9 % low
Resonant Frequency	< 1.5 % low	< 0.5 % high	< 1.0 % low
Effective Height	4 % to 0.5 % high	12.8 % high	2.8 % to 0.6 % low
Radiation Resistance	< 6.0 % high	< 12.0 % high	< 4.0 % high

Table 1 shows computer model results in terms of the percentage difference with measured values. For static capacitance, all calculations were 3 to 5 % low. The agreement for resonant frequency was very good. NECGS predicted consistently higher effective heights (> 10 %), while NEC and MININEC were within 4 % of scale model measurements. The NECGS wire-cage model produced radiation resistances which were high (> 10 %) while NEC and MININEC values were not as high (< 6 %).

## B. TOP-HAT ANTENNA RESULTS

The curves of the normalized electrical properties for the 6-wire top-hat antenna were plotted versus normalized top-hat height ( $H/H$  from Figure 1) in Figures 8 through 19. Table 2 shows normalized computer model results in terms of the percentage difference with normalized measured values. For static capacitance NEC and NECGS were low ( $> 20\%$ ) while MININEC was within  $10\%$ . The results for resonant frequency, effective height, and radiation resistance identify NEC and NECGS numerical models as being less accurate than the MININEC one. Overall, NEC and NECGS results show 2 to 3 times the percentage differences as those of MININEC ( $< 10\%$ ).

REFERENCE MONOPOLE ANTENNA  
WITHOUT TOP-HAT (H/D=200)  
STATIC CAPACITANCE

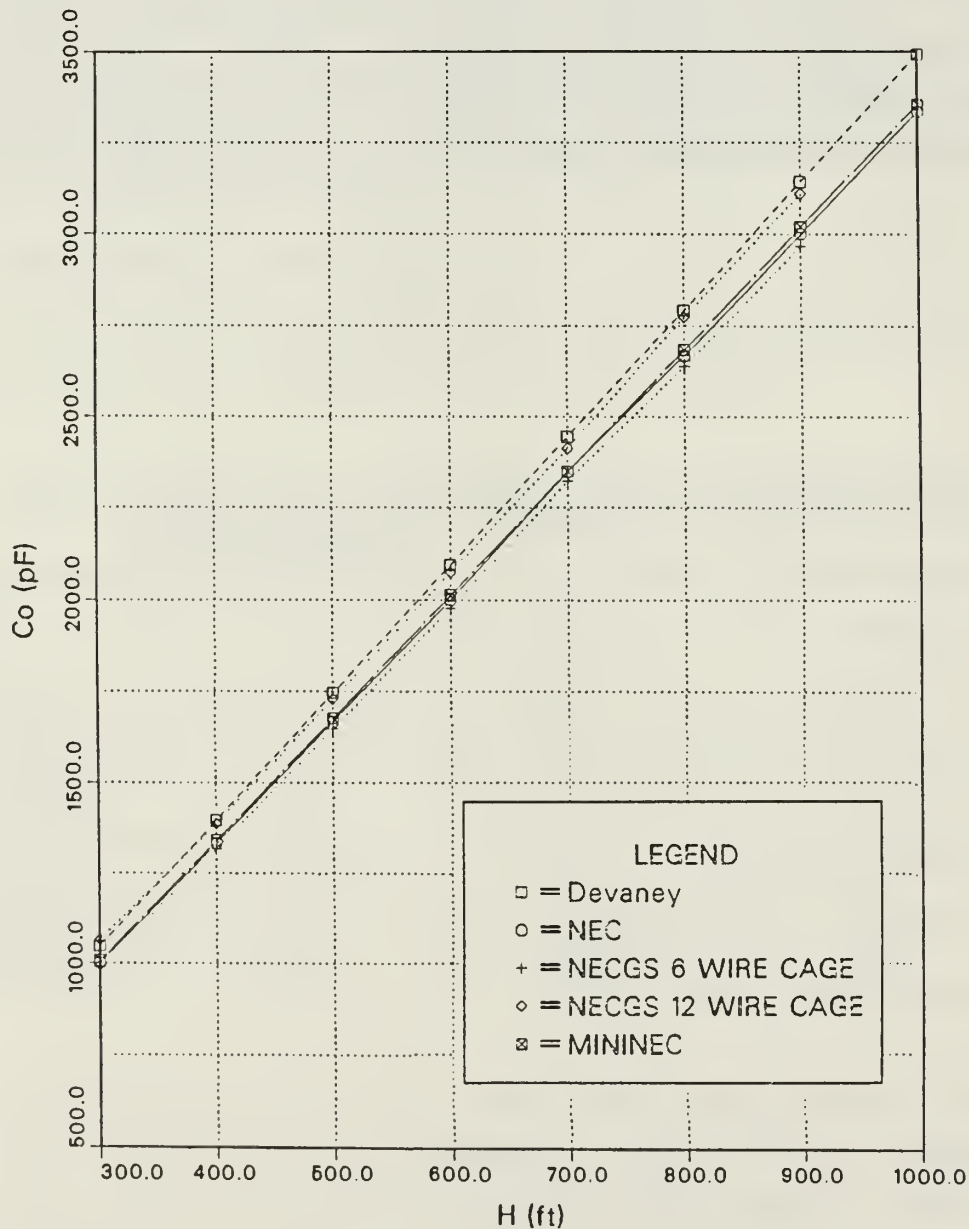

Figure 4. Variation of Static Capacitance of Reference Monopole Antenna as a Function of Antenna Height.

REFERENCE MONOPOLE ANTENNA  
WITHOUT TOP-HAT (H/D=200)  
RESONANT FREQUENCY

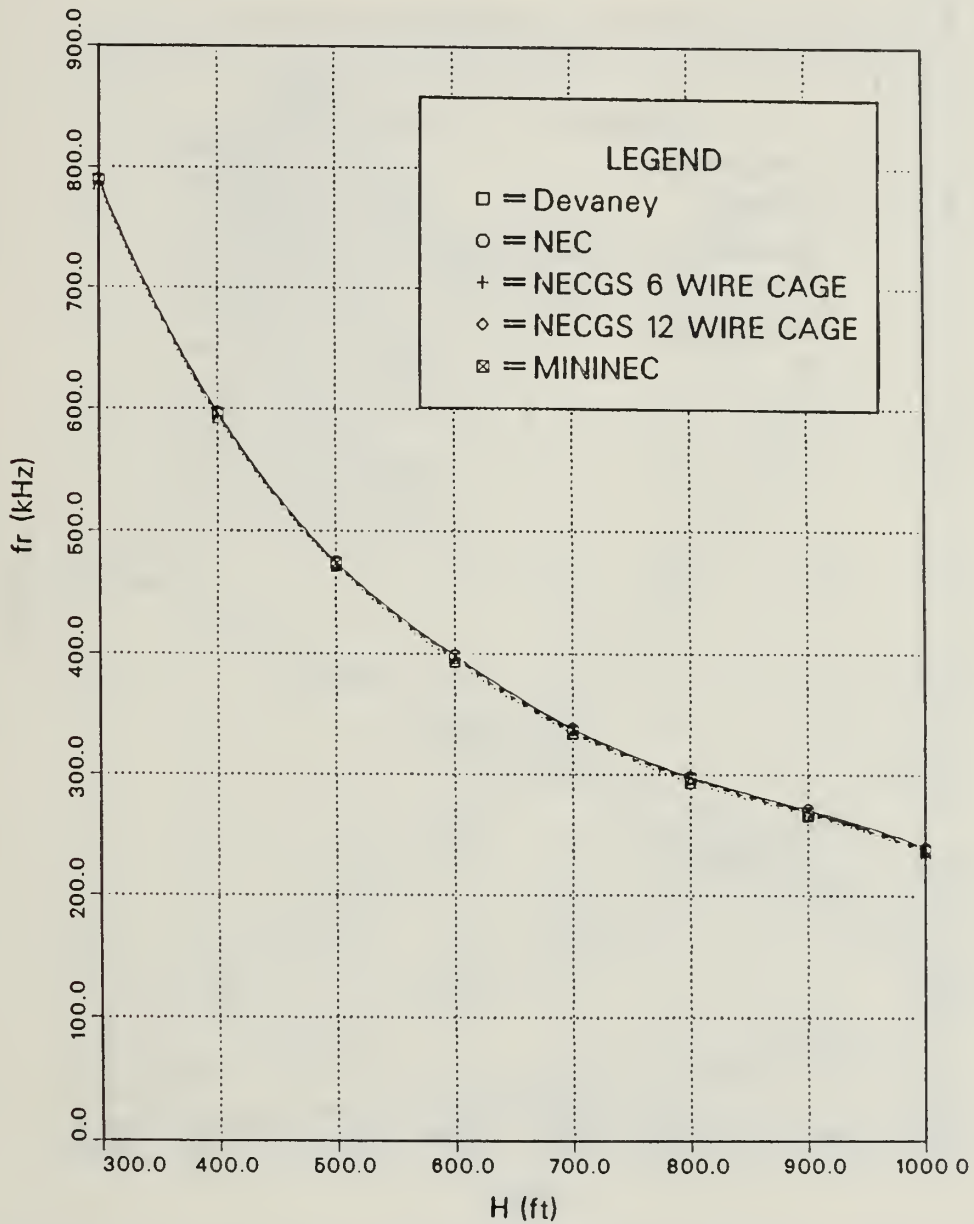

Figure 5. Variation of Resonant Frequency of Reference Monopole Antenna as a Function of Antenna Height.

REFERENCE MONOPOLE ANTENNA  
WITHOUT TOP-HAT (H/D=200)  
EFFECTIVE HEIGHT

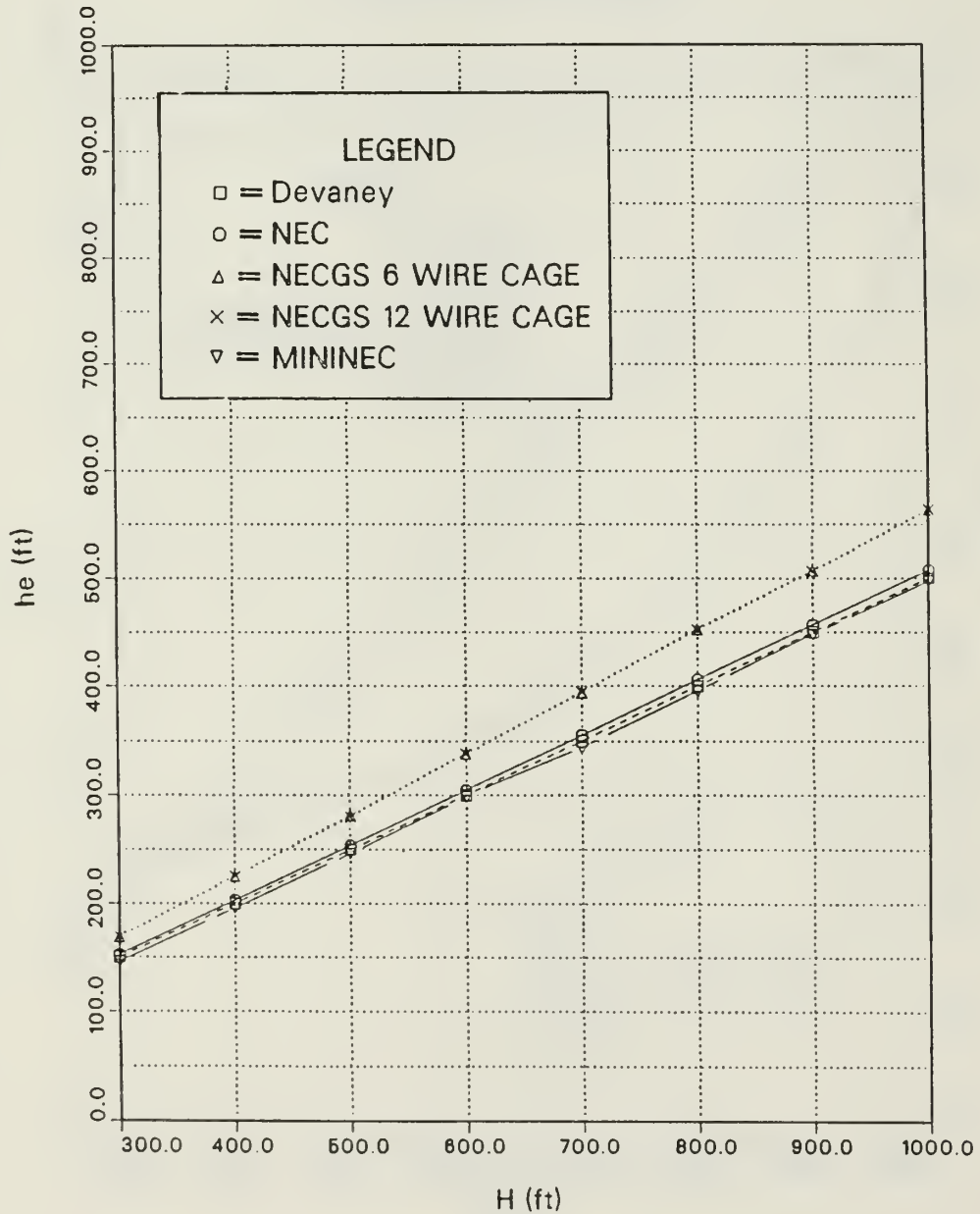

Figure 6. Variation of Effective Height of Reference Monopole Antenna as a Function of Antenna Height.

**REFERENCE MONOPOLE ANTENNA  
WITHOUT TOP-HAT (H/D=200)  
RADIATION RESISTANCE**

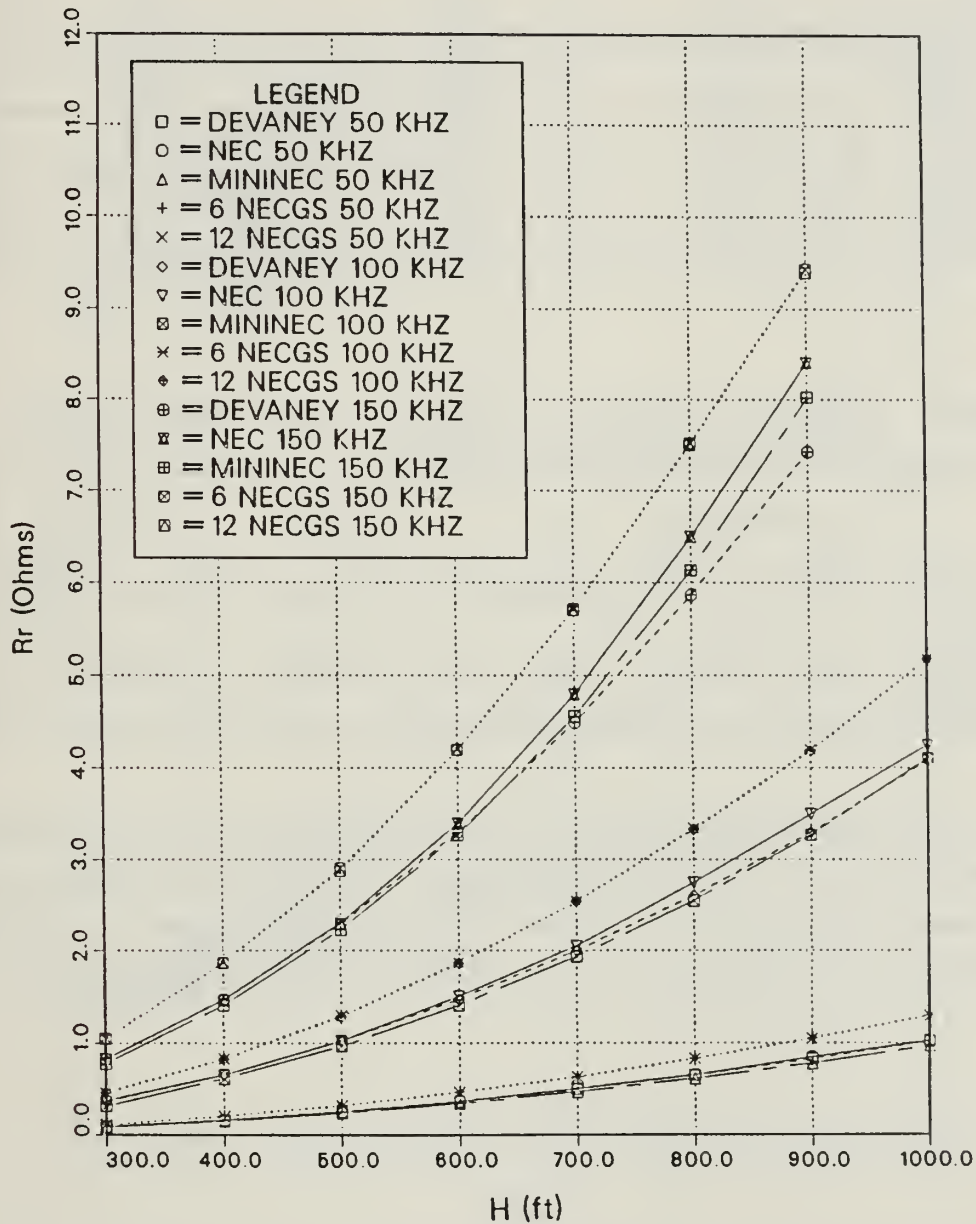

Figure 7. Variation of Radiation Resistance of Reference Monopole Antenna as a Function of Antenna Height.



**Table 2. MAXIMUM PERCENTAGE DIFFERENCE OF CALCULATED 6-WIRE TOP-HAT NORMALIZED ANTENNA PROPERTIES COMPARED WITH MEASUREMENTS**

	NEC	NECGS	MININEC
Static Capacitance	27 % low	24 % low	9 % low
Resonant Frequency	15 % low	5 % high	10 % low
Effective Height	15 % high	16.3 % high	3 % low
Radiation Resistance	12 % high	17 % high	6 % high

**Table 3. OPTIMUM VALUES OF TOP-HAT WIRE LENGTH (H1/H) OF A 6-WIRE TOP-HAT ANTENNA**

	DEVANEY	NEC	NECGS	MININEC
Effective Height	0.3 to 0.4	0.2 to 0.3	0.2 to 0.3	0.3 to 0.4
Radiation Resistance	0.3 to 0.4	0.2 to 0.3	0.2 to 0.3	0.3 to 0.4

In Table 3 the optimum configurations for top-hat loading from MININEC calculations agree closely with values derived via measurements. NEC and NECGS predictions indicate that smaller top-hats are optimum, but the values of the performance parameters can be higher or lower, depending on which parameter is chosen (Figures 8 though 19).

**TOP-HAT MONOPOLE ANTENNA**  
 NORMALIZED STATIC CAPACITANCE  
 NUMBER OF WIRES = 6, (H/D=200)

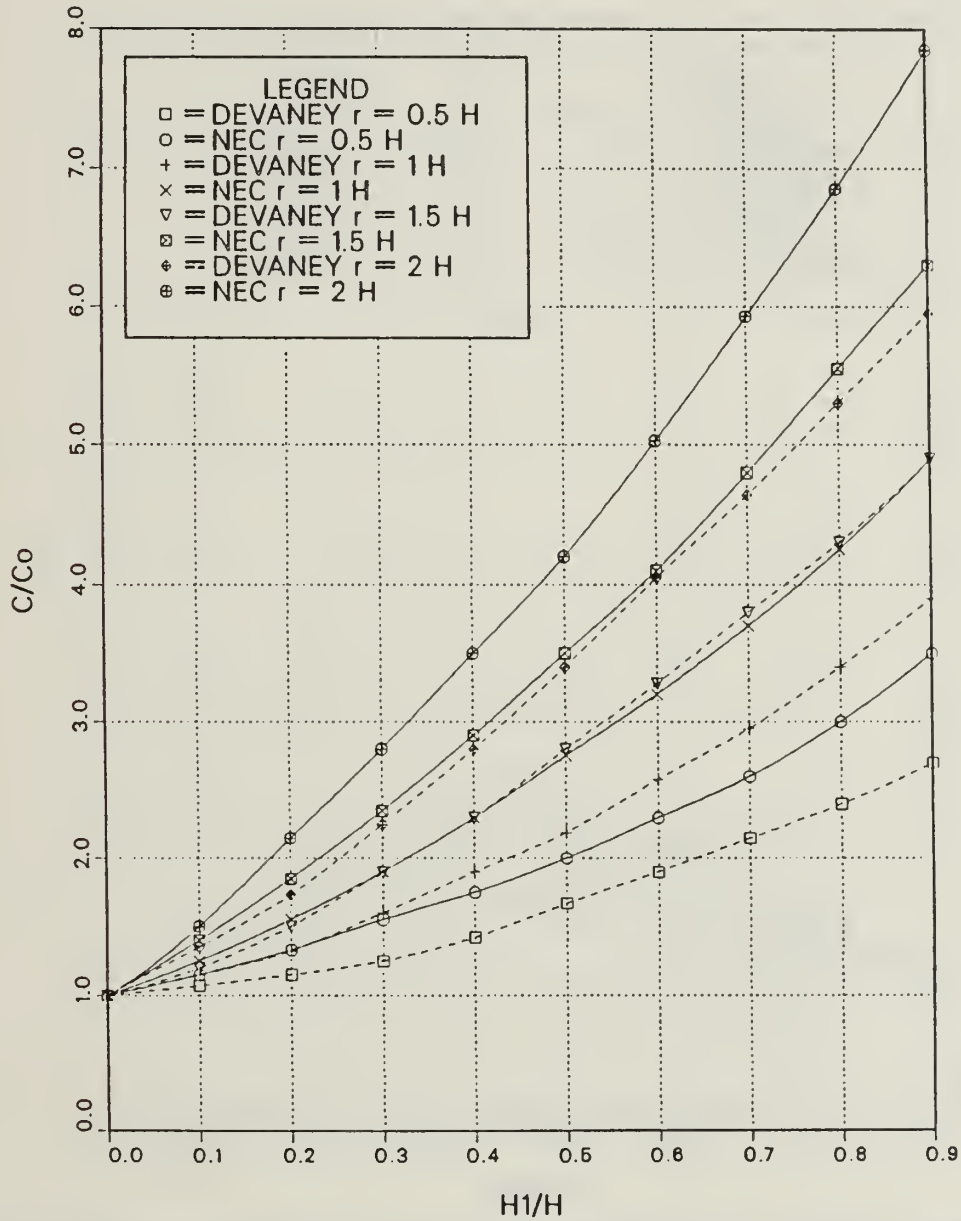

Figure 8. Normalized Static Capacitance of Top-hat Antenna with Radials, N = 6, NEC versus Devaney.

TOP-HAT MONOPOLE ANTENNA  
 NORMALIZED STATIC CAPACITANCE  
 NUMBER OF WIRES = 6, (H/D=200)

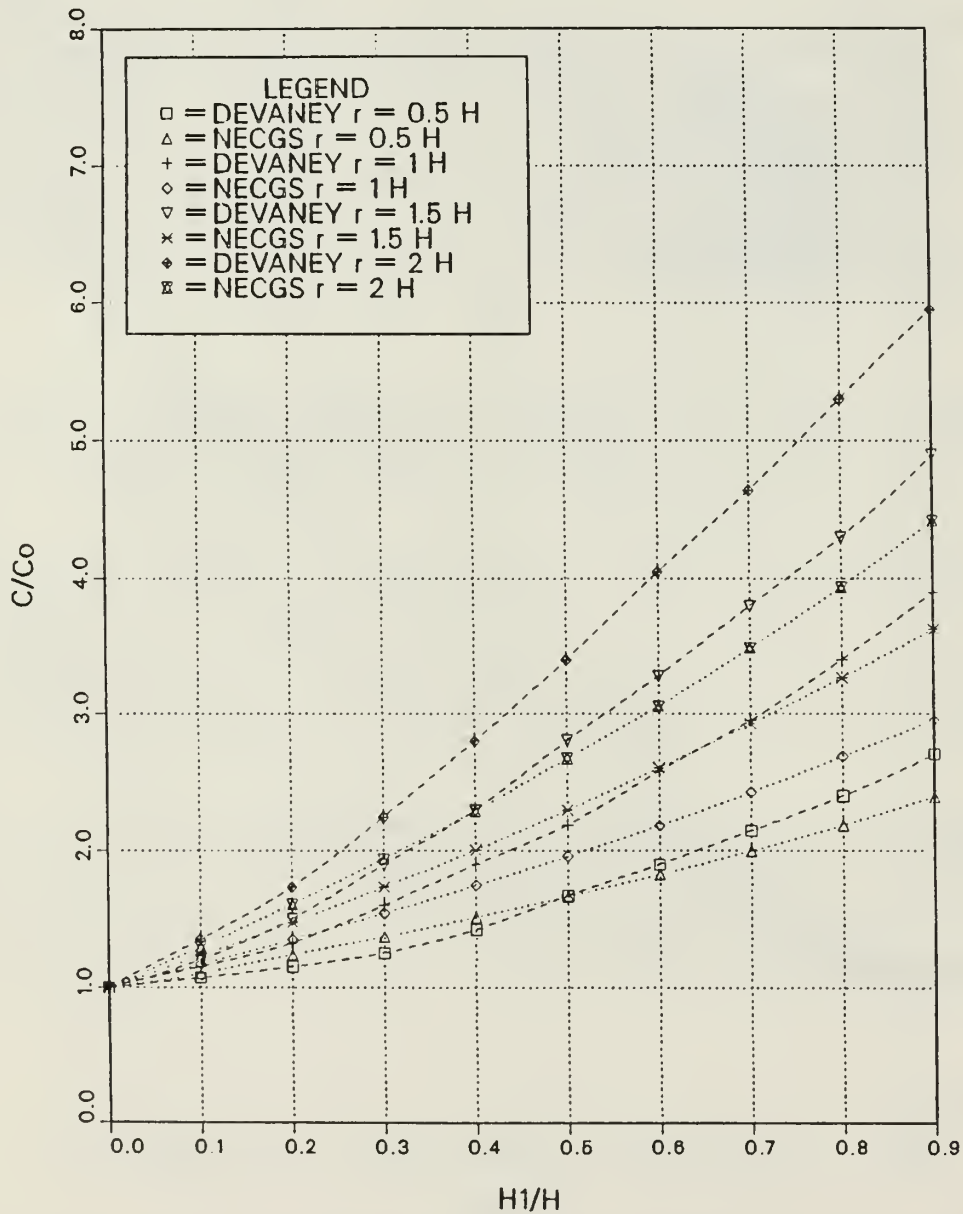

Figure 9. Normalized Static Capacitance of Top-hat Antenna with Radials,  $N = 6$ , NECGS versus Devaney.

TOP-HAT MONOPOLE ANTENNA  
 NORMALIZED STATIC CAPACITANCE  
 NUMBER OF WIRES = 6, (H/D=200)

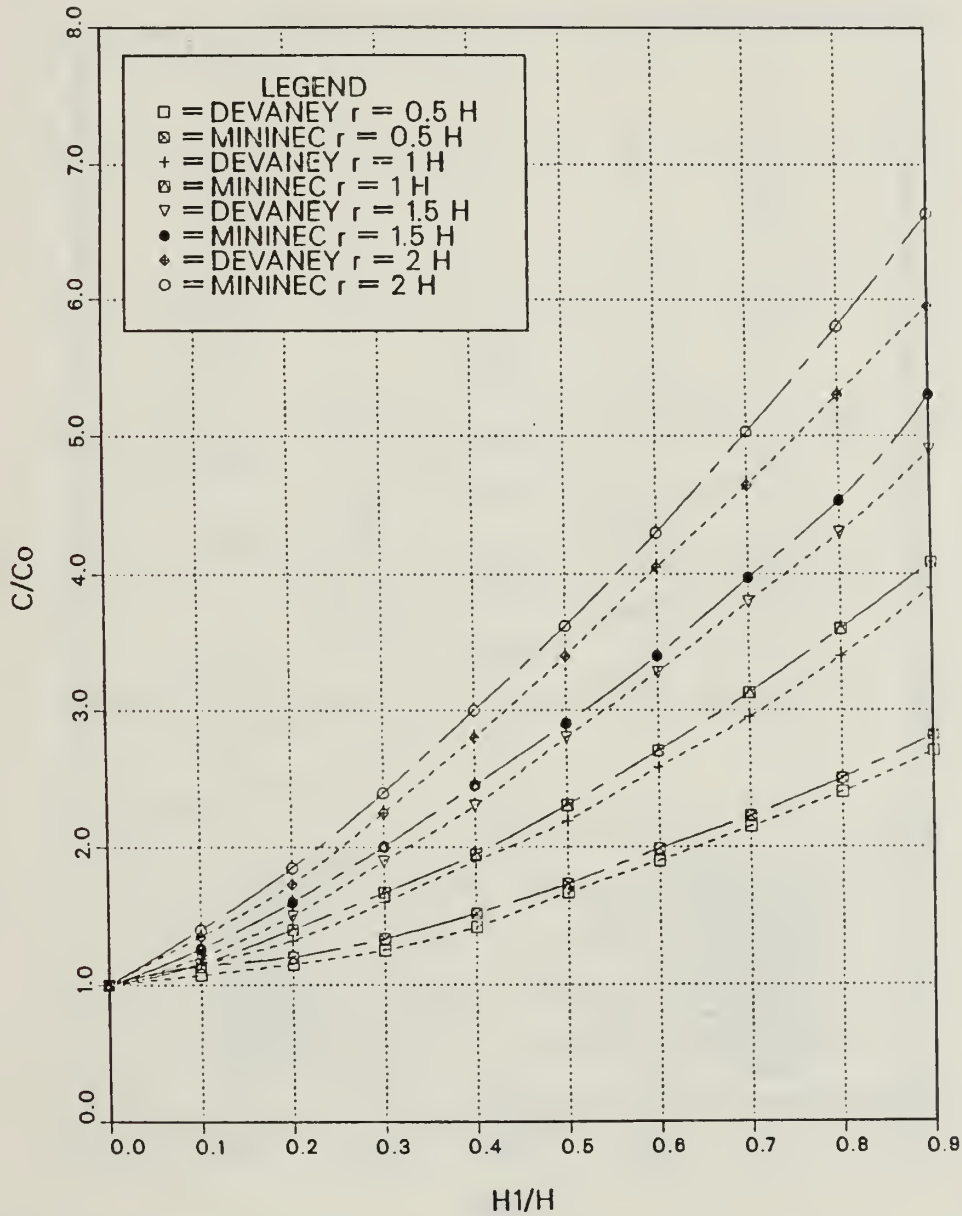

Figure 10. Normalized Static Capacitance of Top-hat Antenna with Radials,  $N = 6$ , MININEC versus Devaney.

**TOP-HAT MONOPOLE ANTENNA**  
 NORMALIZED RESONANT FREQUENCY  
 NUMBER OF WIRES = 6, (H/D=200)

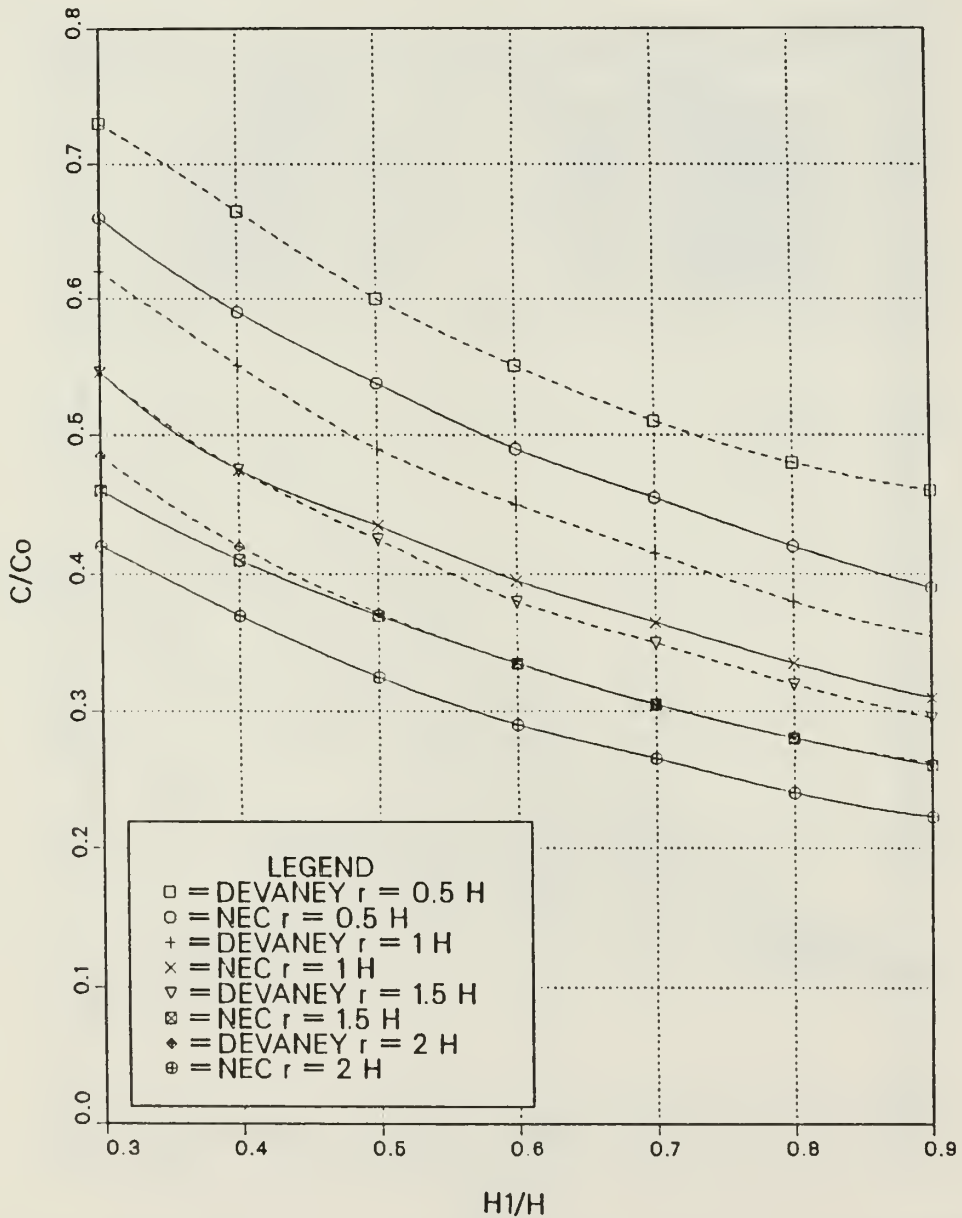

Figure 11. Normalized Resonant Frequency of Top-hat Antenna with Radials,  $N = 6$ , NEC versus Devaney.

TOP-HAT MONOPOLE ANTENNA  
 NORMALIZED RESONANT FREQUENCY  
 NUMBER OF WIRES = 6, (H/D=200)

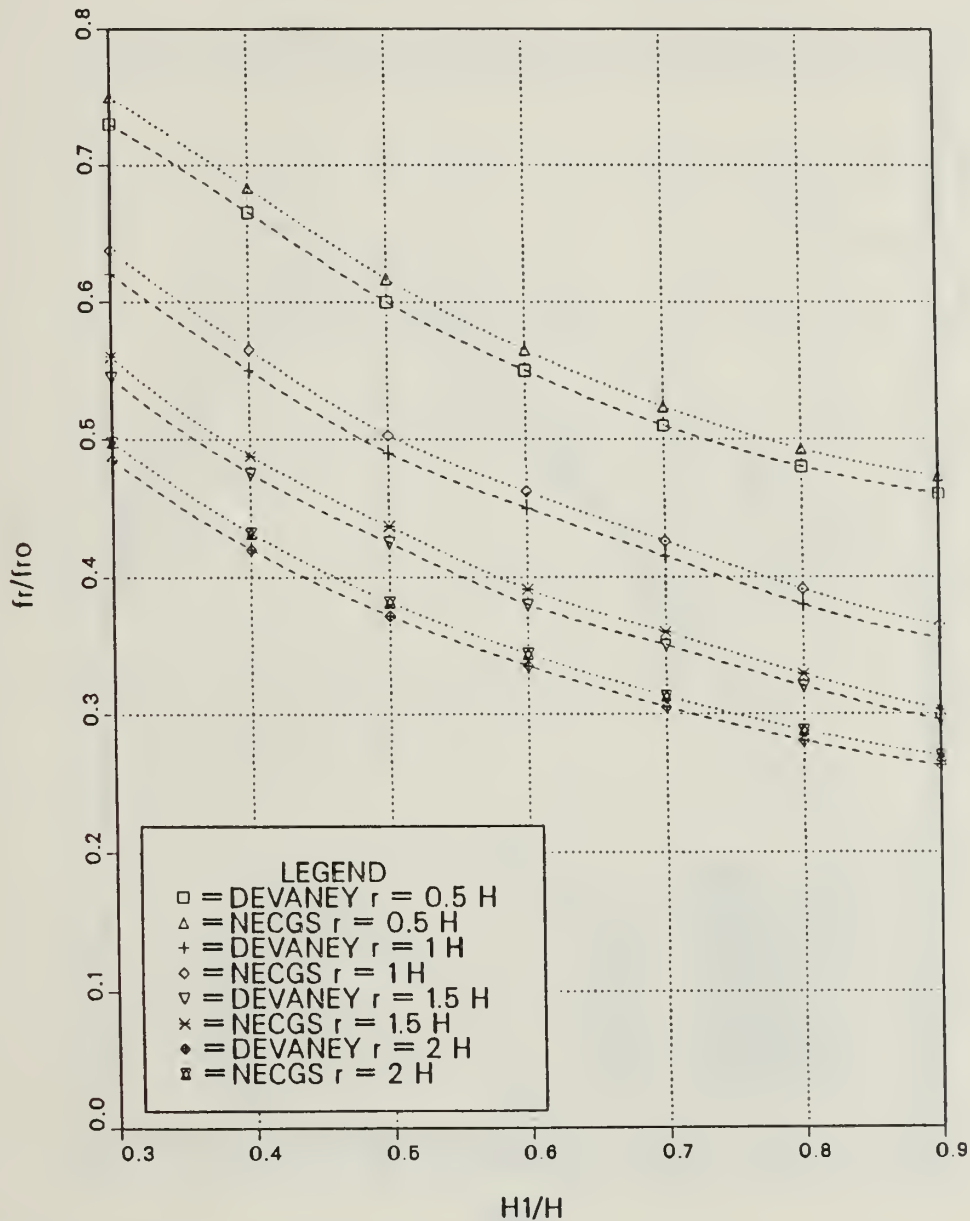

Figure 12. Normalized Resonant Frequency of Top-hat Antenna with Radials,  $N = 6$ , NECGS versus Devaney.

TOP-HAT MONOPOLE ANTENNA  
 NORMALIZED RESONANT FREQUENCY  
 NUMBER OF WIRES = 6, (H/D=200)

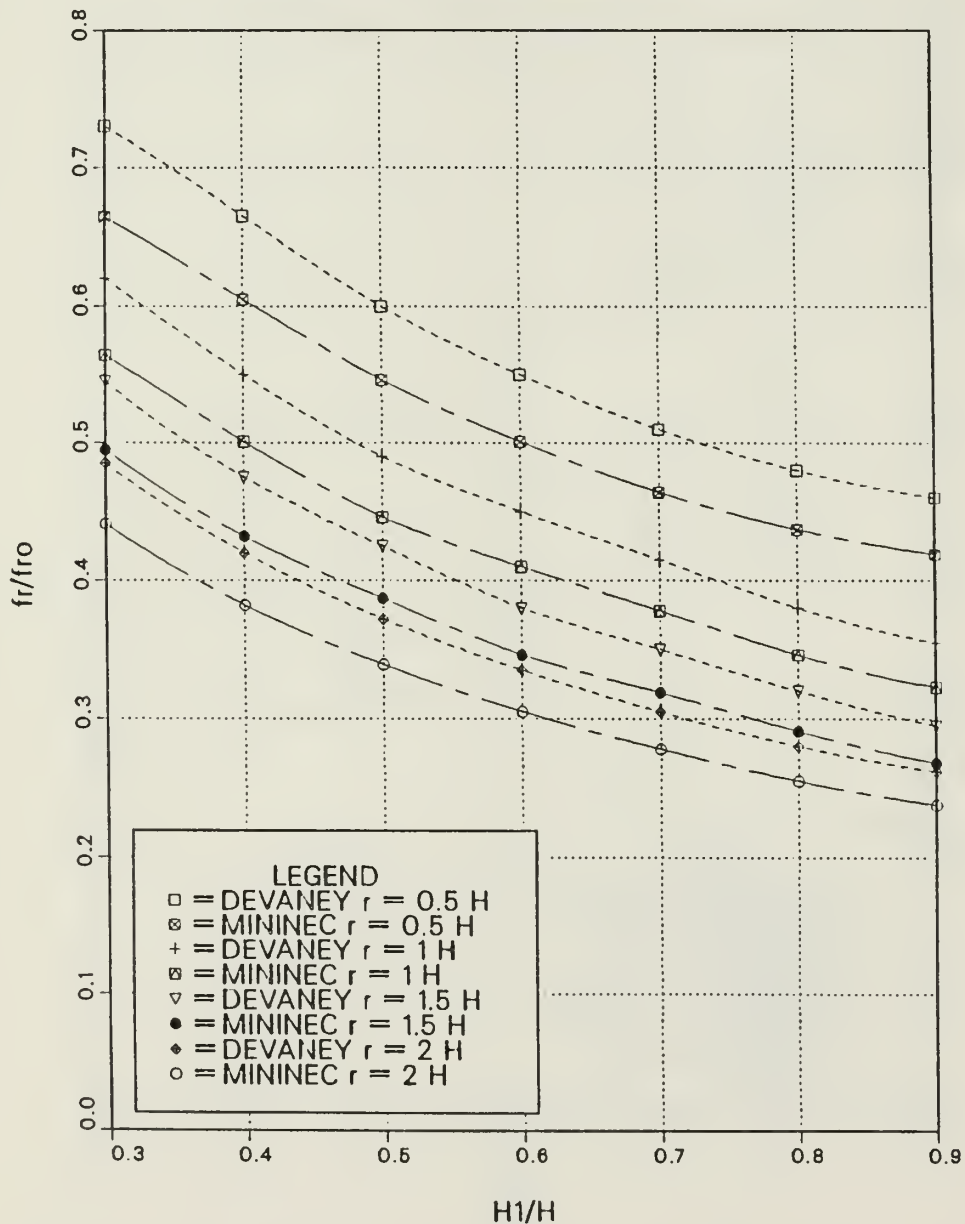

Figure 13. Normalized Resonant Frequency of Top-hat Antenna with Radials,  $N = 6$ , MININEC versus Devaney.

TOP-HAT MONOPOLE ANTENNA  
 NORMALIZED EFFECTIVE HEIGHT  
 NUMBER OF WIRES = 6, (H/D=200)

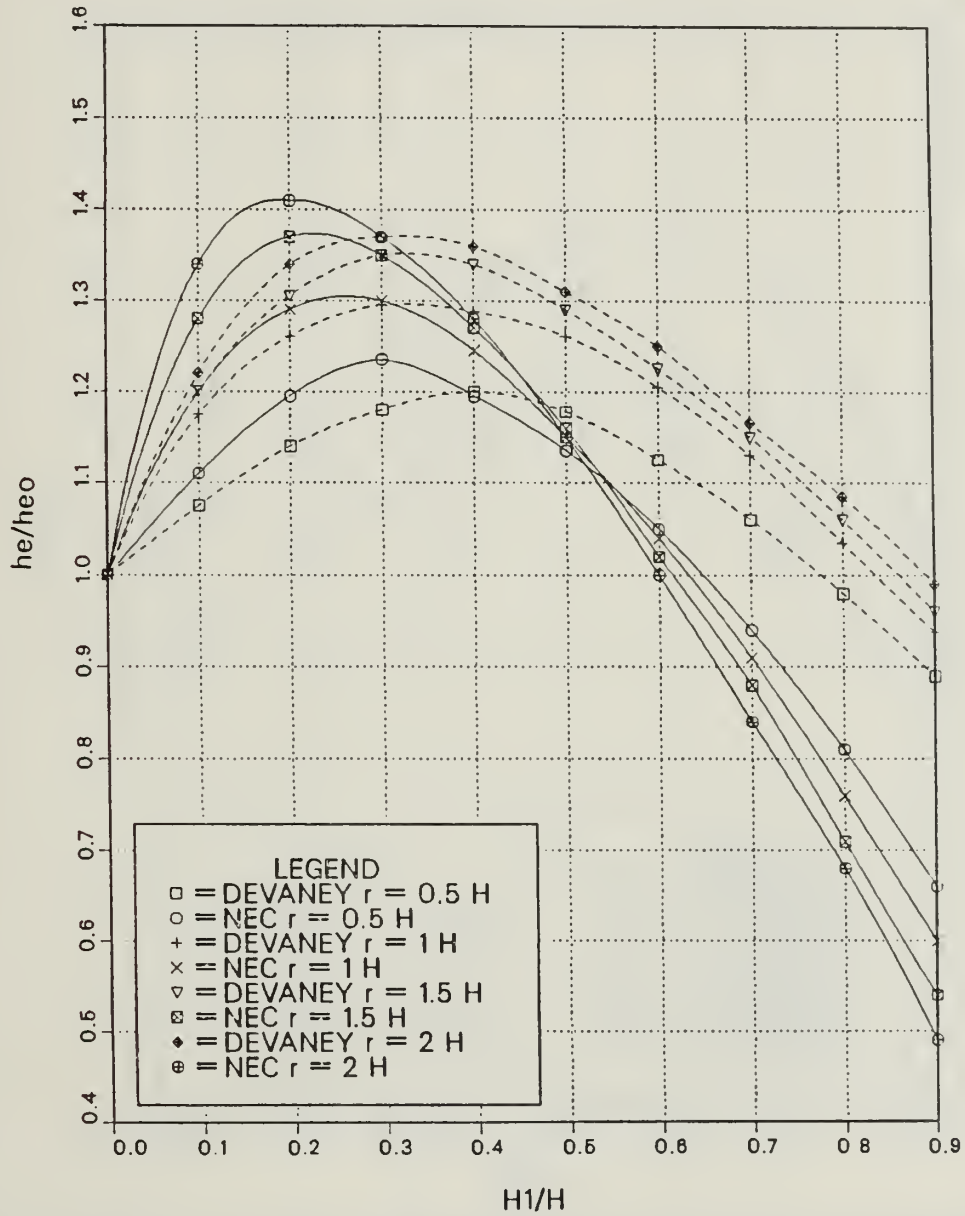

Figure 14. Normalized Effective Height of Top-hat Antenna with Radials,  $N = 6$ , NEC versus Devaney.



TOP-HAT MONOPOLE ANTENNA  
 NORMALIZED EFFECTIVE HEIGHT  
 NUMBER OF WIRES = 6, (H/D=200)

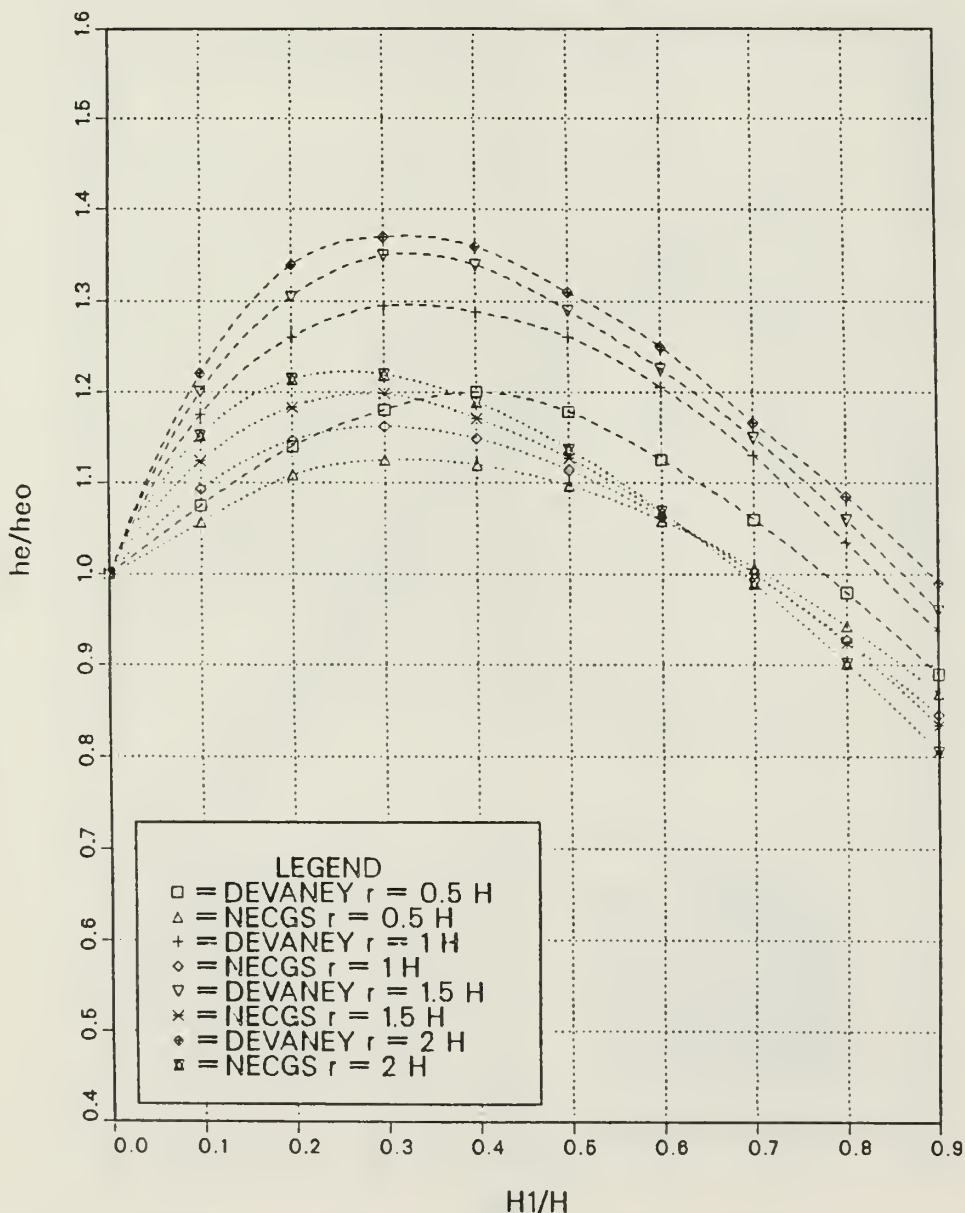

Figure 15. Normalized Effective Height of Top-hat Antenna with Radials,  $N = 6$ , NECGS versus Devaney.

**TOP-HAT MONOPOLE ANTENNA**  
 NORMALIZED EFFECTIVE HEIGHT  
 NUMBER OF WIRES = 6, (H/D=200)

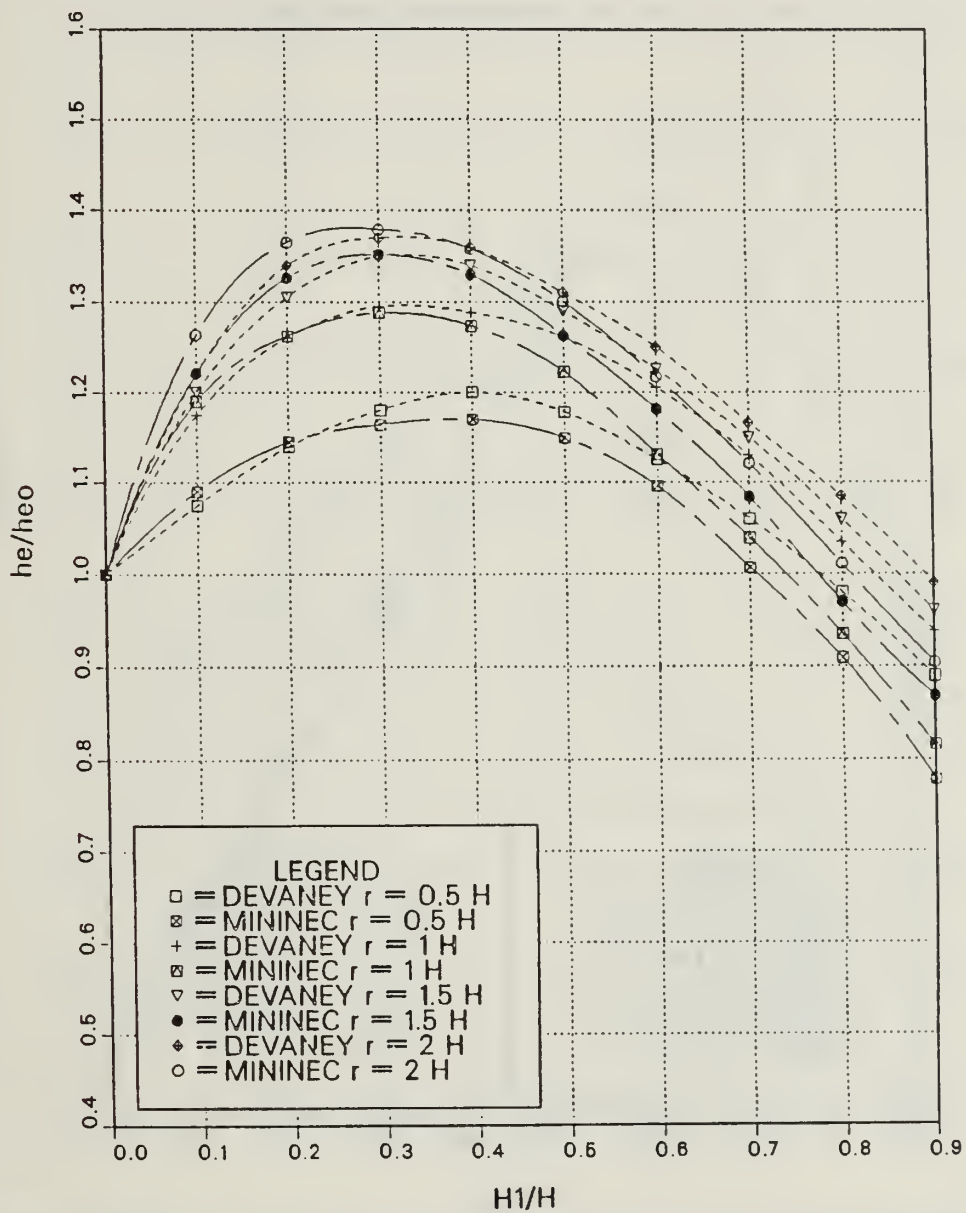

Figure 16. Normalized Effective Height of Top-hat Antenna with Radials,  $N = 6$ , MININEC versus Devaney.

TOP-HAT MONOPOLE ANTENNA  
 NORMALIZED RADIATION RESISTANCE  
 NUMBER OF WIRES = 6, (H/D=200)

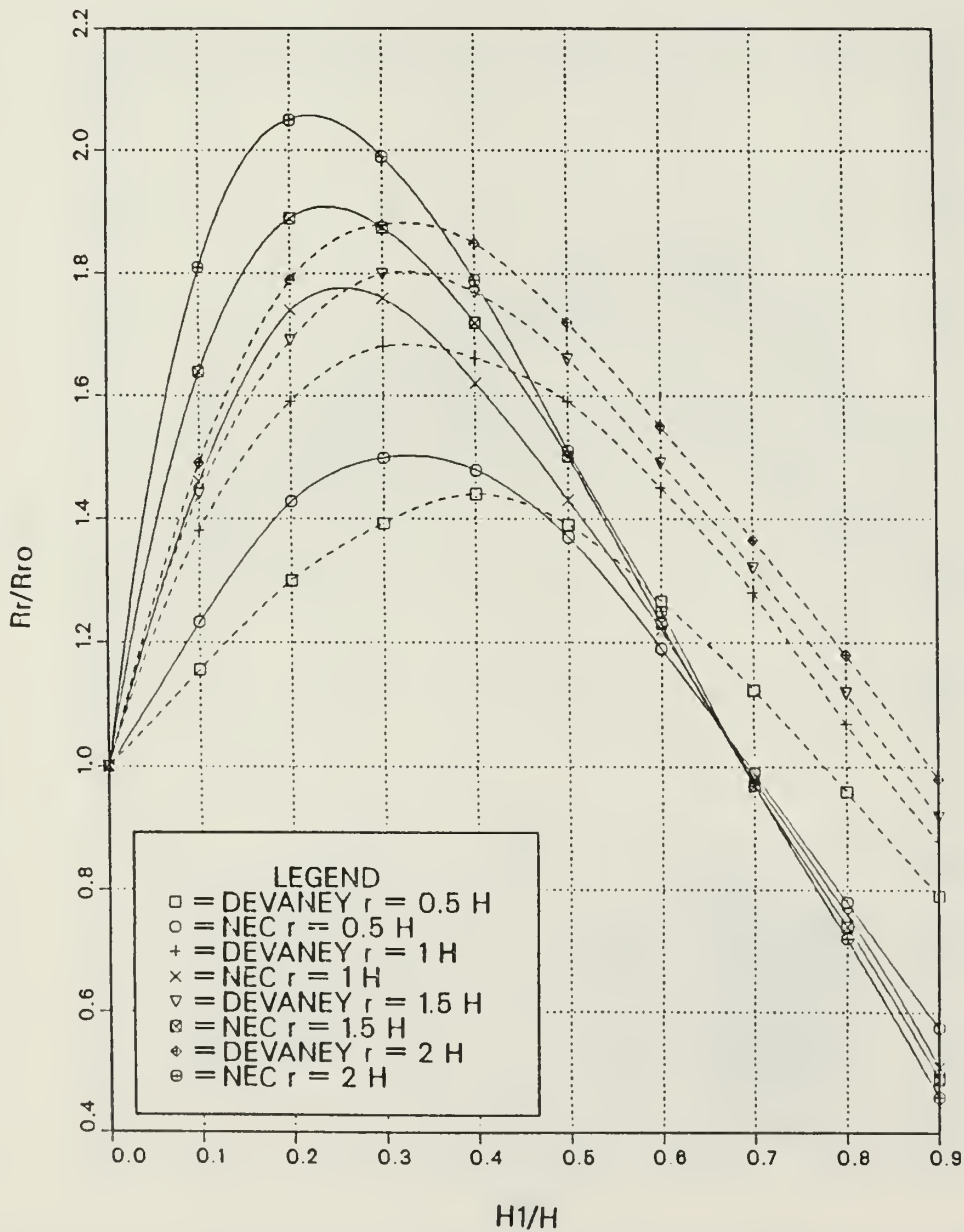

Figure 17. Normalized Radiation Resistance of Top-hat Antenna with Radials,  $N = 6$ , NEC versus Devaney.

TOP-HAT MONOPOLE ANTENNA  
 NORMALIZED RADIATION RESISTANCE  
 NUMBER OF WIRES = 6, (H/D=200)

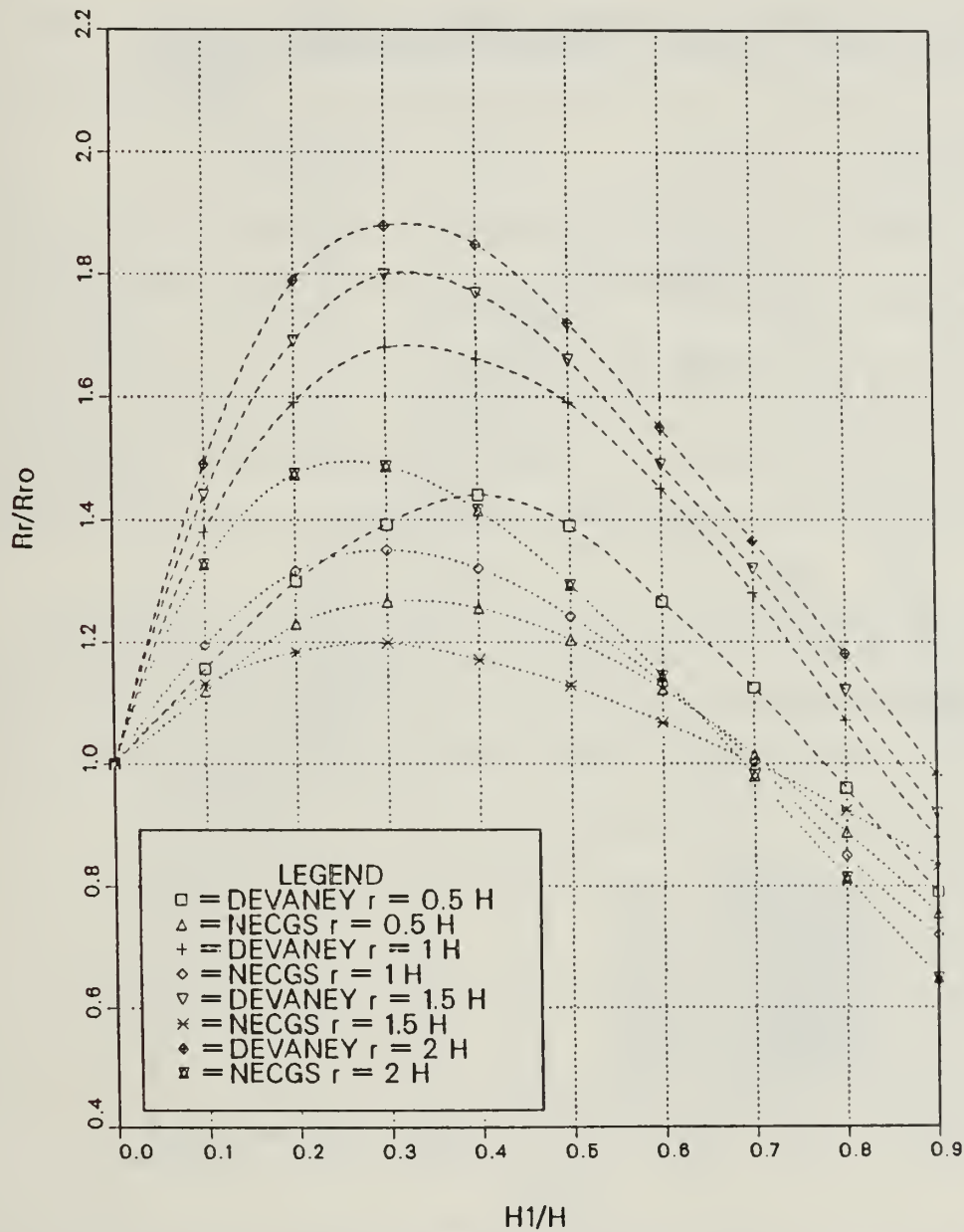

Figure 18. Normalized Radiation Resistance of Top-hat Antenna with Radials,  $N = 6$ , NECGS versus Devaney.

**TOP-HAT MONOPOLE ANTENNA**  
 NORMALIZED RADIATION RESISTANCE  
 NUMBER OF WIRES = 6, (H/D=200)

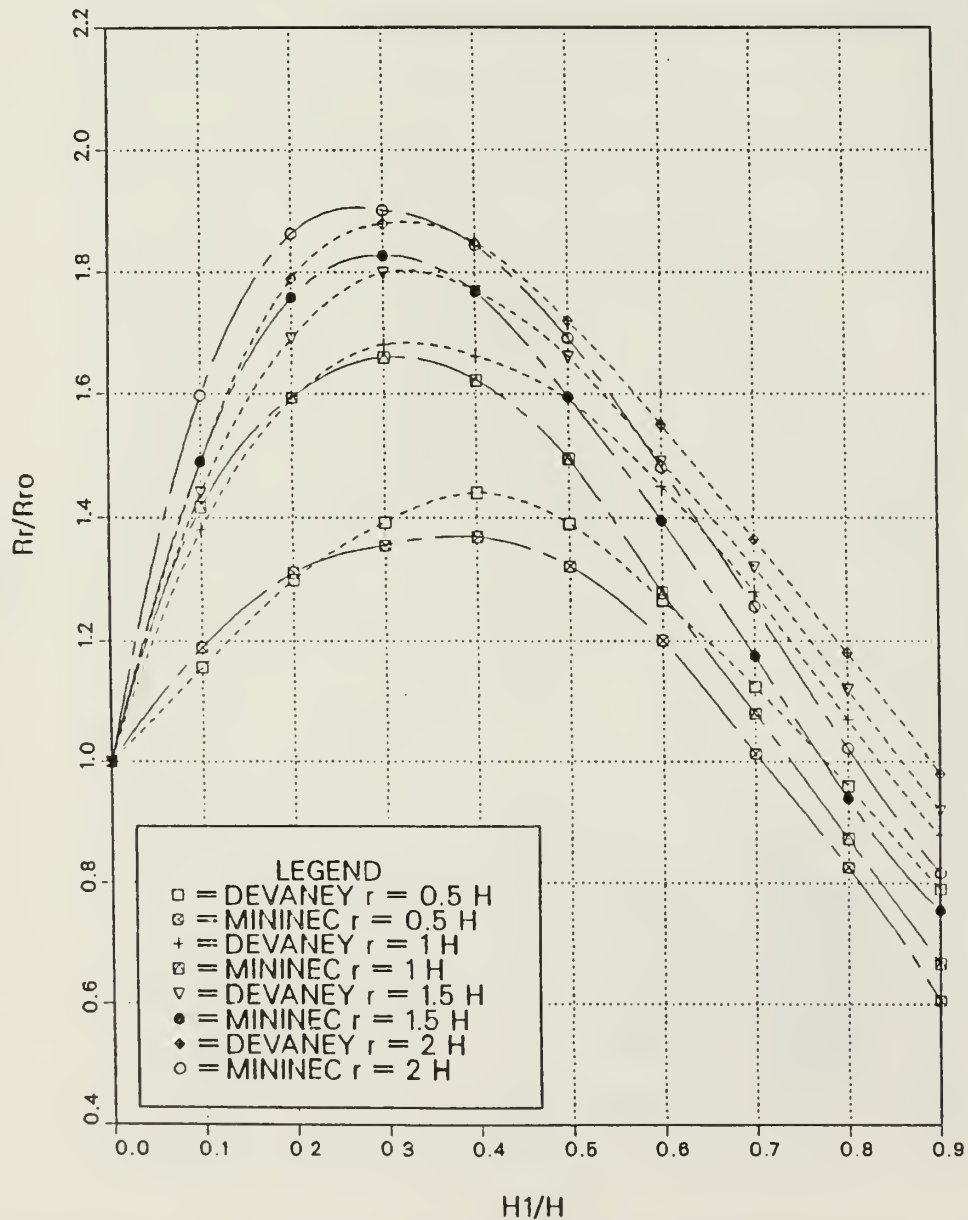

Figure 19. Normalized Radiation Resistance of Top-hat Antenna with Radials,  $N = 6$ , MININEC versus Devaney.

The curves of the normalized electrical properties for the corresponding 12-wire top-hat antenna are plotted versus normalized top-hat height (H1 H) in Figures 20 through 31 (Appendix B). Table 4 shows changes in performance obtained by doubling the number of top-hat wires from 6 to 12.

**Table 4. COMPARISON OF PERFORMANCE PARAMETER CHANGE WHEN INCREASING TOP-HAT RADIALS FROM 6 TO 12 WIRES.**

	DEVANEY	NEC	NECGS	MININEC
Static Capacitance	68% high	72% high	63% high	48% high
Resonant Frequency	11% low	7.5% low	10.1% low	6.5% low
Effective Height	8% high	5% high	5% high	8% high
Radiation Resistance	21% high	8% high	7% high	17% high

The performance changes in static capacitance and resonant frequency obtained for scale-model measurements are most closely predicted by NECGS and NEC. MININEC, NECGS, and NEC all produced good results for effective height improvement. Measured radiation resistance change is matched best by MININEC results.

#### IV. CONCLUSIONS AND RECOMMENDATIONS

This thesis presented the results of several numerical models of LF top-hat monopole antennas using NECGS and MININEC and compared performance parameters with scale-model measurements and with earlier NEC results. A reference monopole was first used for bench-marking. Static capacitance and resonant frequency were predicted very well by all three codes. Effective height and radiation resistance were very close for the MININEC model and were acceptable (within 6 %) for NEC. These results are expected since no change-of-radius existed. NECGS employed a wire-cage equivalence to the actual cylindrical antenna, an approximation which has proven to be valid for resonant ( $\sim \frac{\lambda}{4}$ ) monopoles. In this case for a short monopole, the cage equivalence seems less appropriate since the NECGS differences are as high as 13 %.

For 6-wire top-hat loaded monopoles, the computer modeling results were good for MININEC which handles change-of-radii better than NEC. The NECGS cage model was anticipated to be able to overcome the radius change limitation by employing constant radius wires throughout. Resonant frequency was predicted very accurately by NECGS but for static capacitance, effective height, and radiation resistance it was very poor. As previously shown, NEC performed very poorly for all top-loaded parameters.

The need for design information prompted early investigators of top-hat antennas to study the optimum configuration of top-hat wires. The results of their measurements on scale model antennas provided optimum top-hat geometry which was most closely predicted by MININEC. The measured improvements which can be obtained by increasing the number of top-hat wires were demonstrated by all three codes.

Recommendations include:

- Additional investigation of the cage equivalency to a cylindrical conductor is needed.
- The change-of-radius limitation of NEC, further demonstrated by this investigation, continues to be very serious problem needing solution.

## APPENDIX A. THE NUMERICAL ELECTROMAGNETICS CODE (NEC)

The Numerical Electromagnetics Code (NEC) is an advanced version of a computer code for analysis of the performance of antenna models, developed by the Lawrence Livermore Laboratory, Livermore, Ca., under the initial sponsorship of the Naval Ocean System Center and the Air Force Weapons Laboratory. It has comprehensive capabilities for analyzing the electromagnetic response of n arbitrary antenna structures consisting of wires or surfaces in free space or above a perfectly conducting ground or over finitely conducting earth. A special purpose NEC-3 version has been developed called the Numerical Electromagnetics Code-Ground Screen (NECGS). NECGS is very efficient to use, runs quickly, and is good for a vertical monopole on a uniform radial wire ground screen.

NEC and NECGS use an electric field integral equation (EFIE) and a magnetic field integral equation (MFIE) to model the electromagnetic response of general structures [Ref. 4]. The EFIE is best for thin wire structures of small or vanishing conductor volume whereas the MFIE is more efficient for large smooth closed surfaces. The EFIE and MFIE are coupled when used for a structure containing wires and surfaces.

The EFIE for thin wires used in NEC is given by:

$$-\hat{s} \bar{E}^{inc}(\bar{r}) = \frac{-j}{4\pi\omega\epsilon} \int_{c(\bar{r})} I(s') \left( \hat{s} \hat{s}' k^2 - \frac{\hat{c}^2}{\partial s \partial s'} \right) g(\bar{r}, \bar{r}') ds' \quad (11)$$

where

$\hat{s}$  is the distance along the wire axis  $r$

$\hat{s}'$  is the unit vector along the wire axis

$\bar{E}^{inc}(\bar{r})$  is the incident electric field at  $r$ .

$\omega$  is  $2\pi f$

$\epsilon$  is the permittivity

$I(s')$  is the axial current

$k$  is  $\omega \sqrt{\mu\epsilon}$

$\mu$  is the permeability

$\bar{r}$  is the source point

$\bar{r}'$  is the observation point



$g(\vec{r}, \vec{r}')$  is  $\exp(-jkR)/R$ , the free space Green's function, and  $R$  is  $|\vec{r} - \vec{r}'|$ .

**APPENDIX B. PERFORMANCE DATA FOR 12-WIRE TOP-HAT ANTENNAS**

**Table 5. MAXIMUM PERCENTAGE DIFFERENCE OF CALCULATED 12-WIRE TOP-HAT NORMALIZED ANTENNA PROPERTIES COMPARED WITH MEASUREMENTS**

	NEC	NECGS	MININEC
Static Capacitance	30 % low	27 % low	9 % low
Resonant Frequency	12 % low	4 % high	9.5 % low
Effective Height	15 % high	18 % high	1.5 % low
Radiation Resistance	13 % high	23 % high	7 % high

**Table 6. OPTIMUM VALUES OF TOP-HAT WIRE LENGTH (H1/H) OF A 12-WIRE TOP-HAT ANTENNA**

	DEVANEY	NEC	NECGS	MININEC
Effective Height	0.3 to 0.4	0.2 to 0.3	0.2 to 0.3	0.3 to 0.4
Radiation Resistance	0.3 to 0.4	0.2 to 0.3	0.2 to 0.3	0.3 to 0.4

TOP-HAT MONOPOLE ANTENNA  
 NORMALIZED STATIC CAPACITANCE  
 NUMBER OF WIRES = 12, (H/D=200)

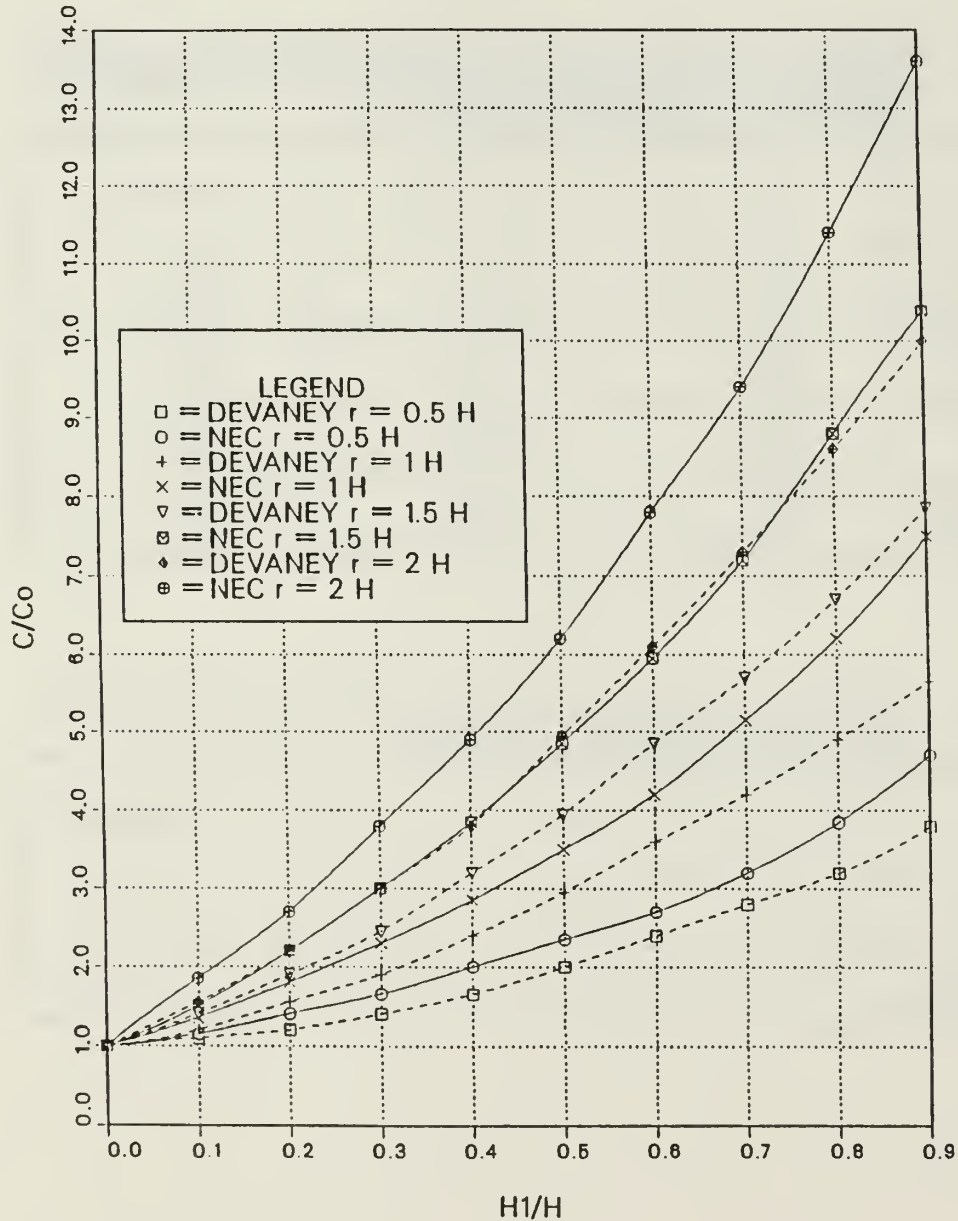

Figure 20. Normalized Static Capacitance of Top-hat Antenna with Radials,  $N = 12$ , NEC versus Devaney.

**TOP-HAT MONOPOLE ANTENNA**  
 NORMALIZED STATIC CAPACITANCE  
 NUMBER OF WIRES = 12, ( $H/D \approx 200$ )

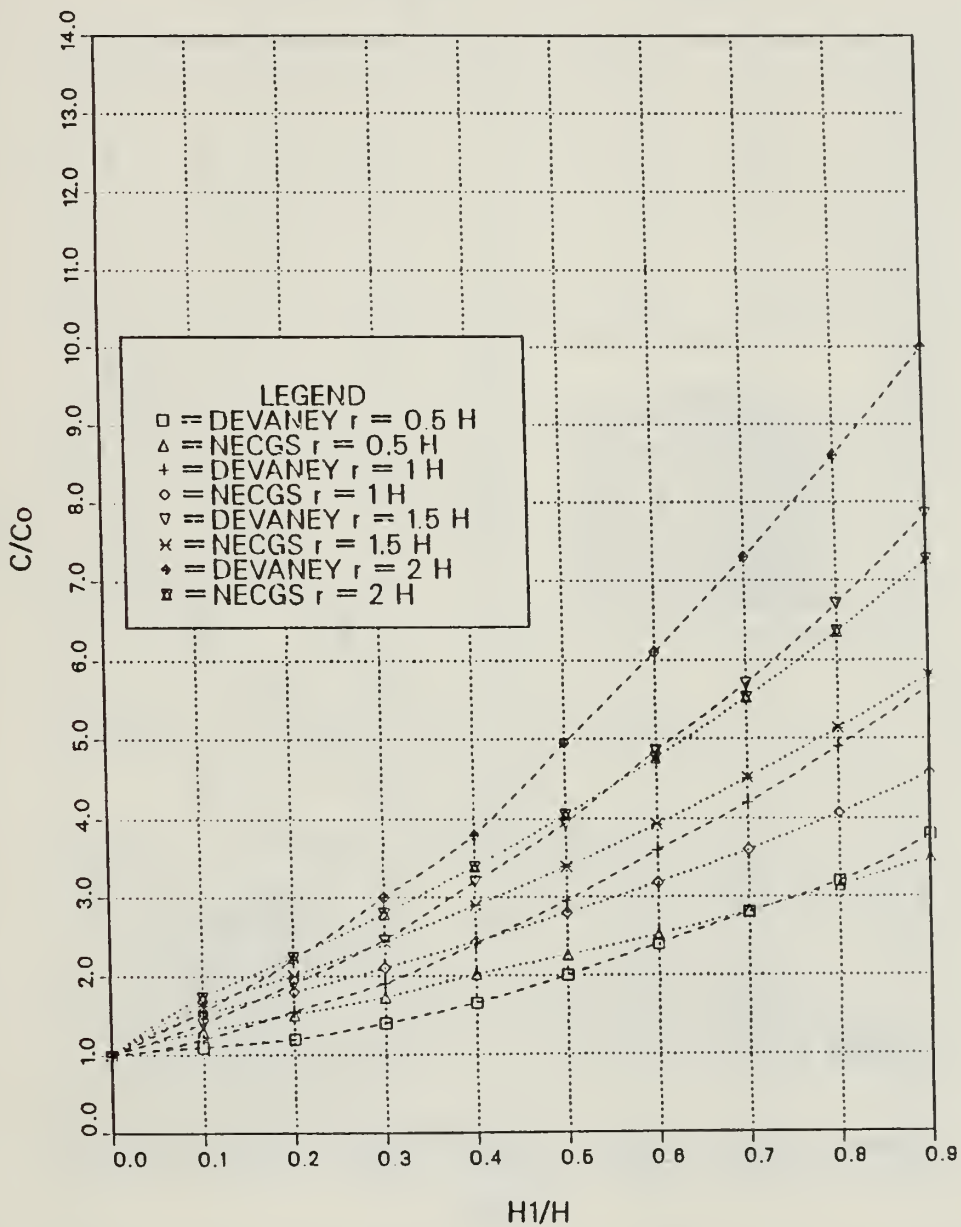

Figure 21. Normalized Static Capacitance of Top-hat Antenna with Radials,  $N = 12$ , NECGS versus Devaney.

# TOP-HAT MONOPOLE ANTENNA

## NORMALIZED STATIC CAPACITANCE

NUMBER OF WIRES = 12, (H/D=200)

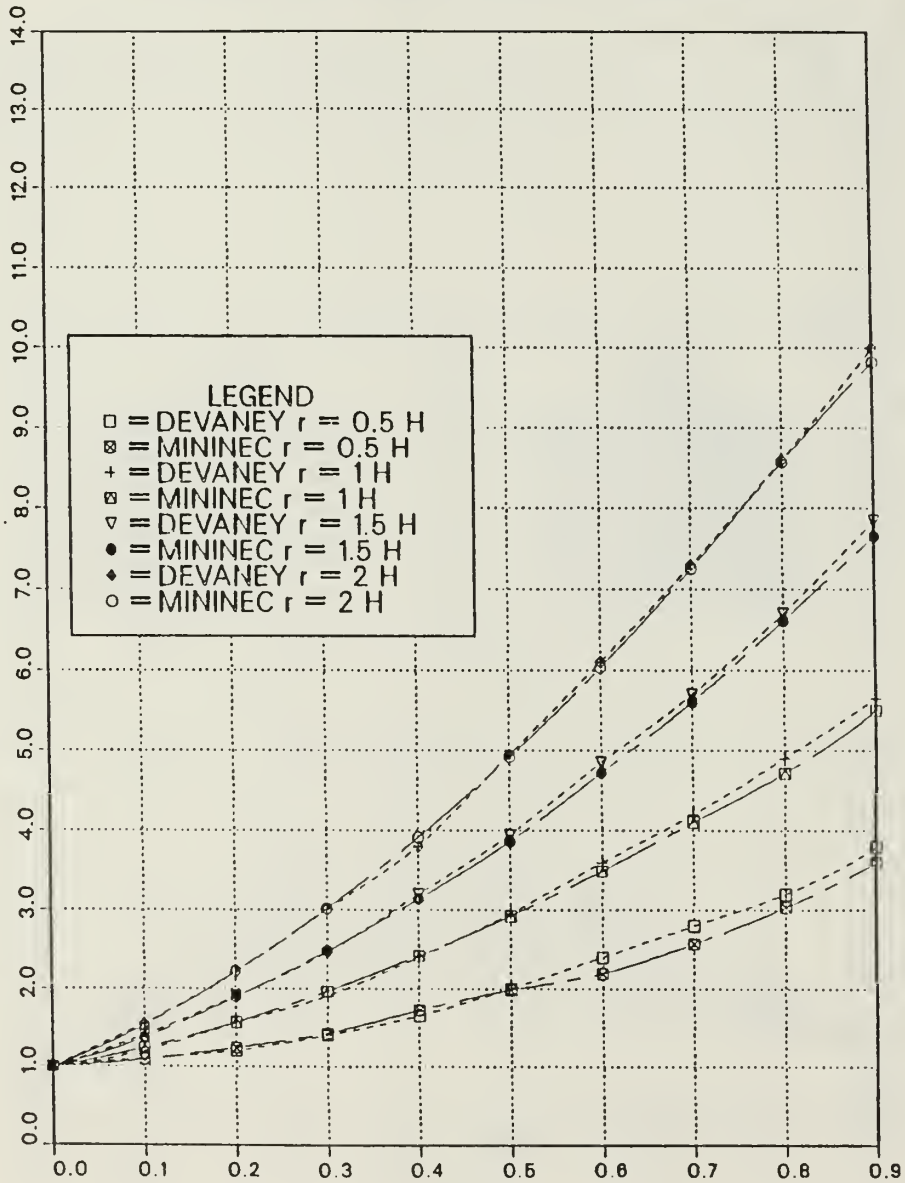

Figure 22. Normalized Static Capacitance of Top-hat Antenna with Radials,  $N = 12$ , MININEC versus Devaney.

**TOP-HAT MONOPOLE ANTENNA**  
**NORMALIZED RESONANT FREQUENCY**  
 NUMBER OF WIRES = 12, (H/D=200)

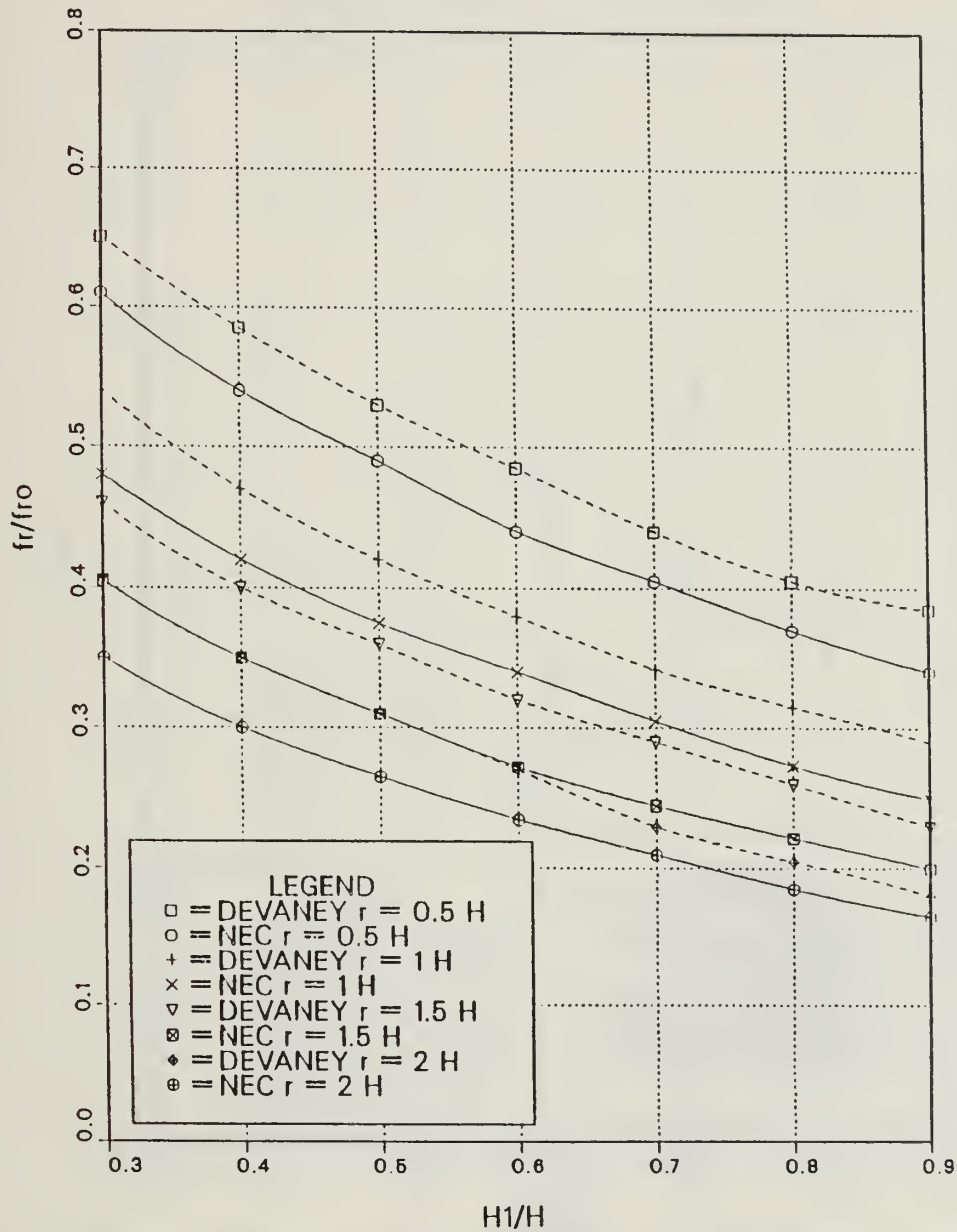

Figure 23. Normalized Resonant Frequency of Top-hat Antenna with Radials,  $N = 12$ , NEC versus Devaney.

**TOP-HAT MONOPOLE ANTENNA**  
**NORMALIZED RESONANT FREQUENCY**  
 (NUMBER OF WIRES = 12,  $H/D=200$ )

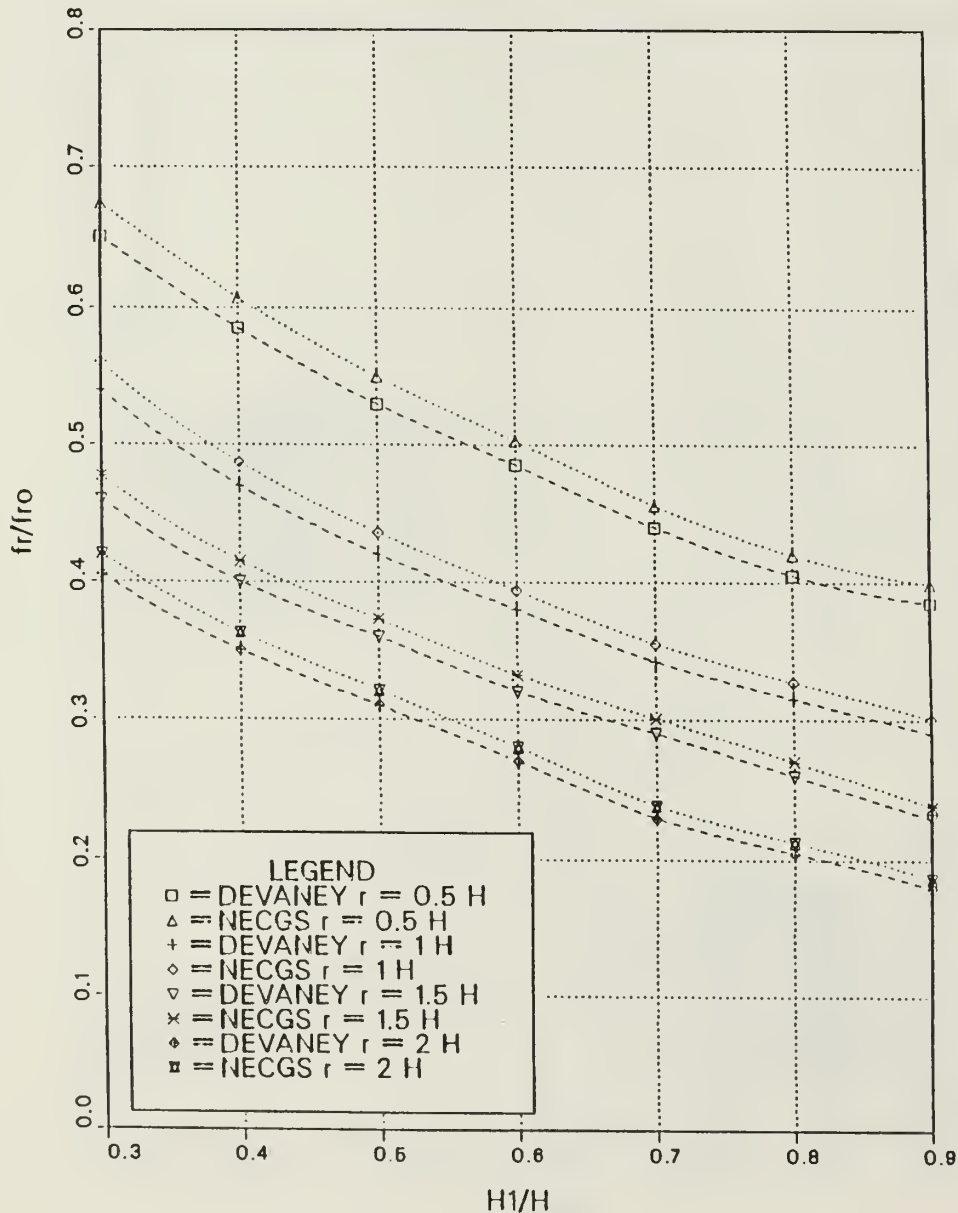

Figure 24. Normalized Resonant Frequency of Top-hat Antenna with Radials,  $N = 12$ , NECGS versus Devaney.

TOP-HAT MONOPOLE ANTENNA  
 NORMALIZED RESONANT FREQUENCY  
 NUMBER OF WIRES = 12, (H/D=200)

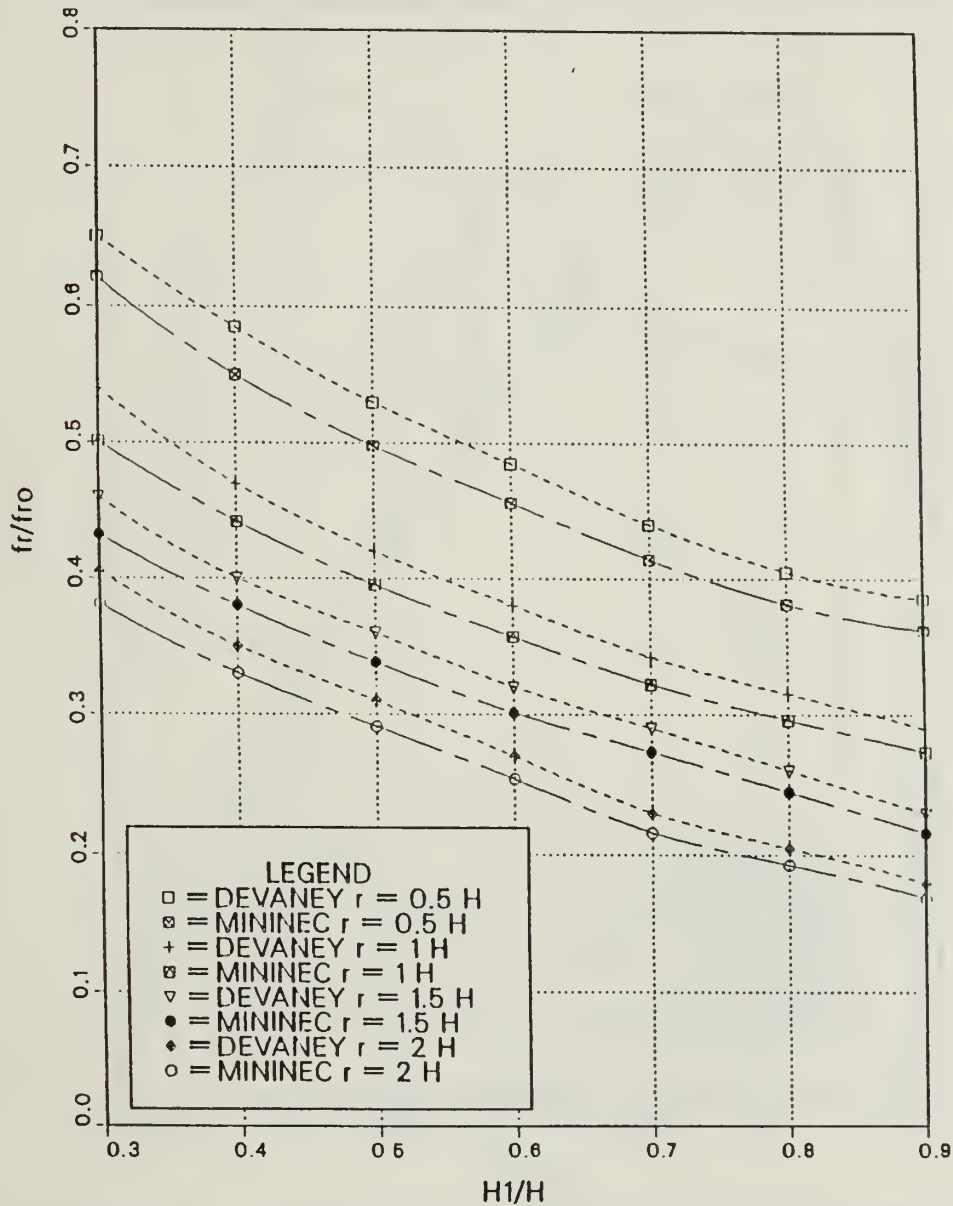

Figure 25. Normalized Resonant Frequency of Top-hat Antenna with Radials,  $N = 12$ , MININEC versus Devaney.



TOP-HAT MONOPOLE ANTENNA  
 NORMALIZED EFFECTIVE HEIGHT  
 NUMBER OF WIRES = 12, (H/D=200)

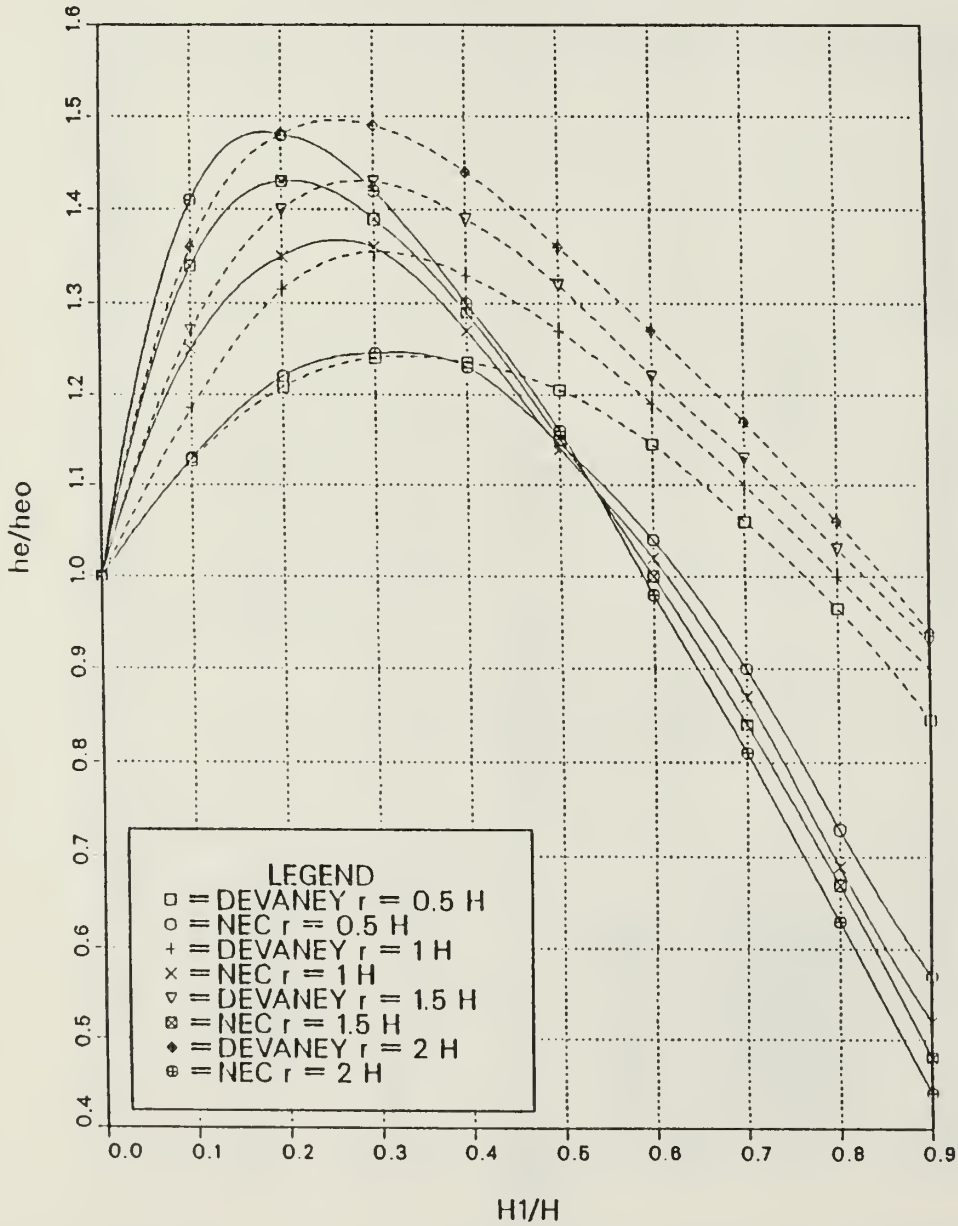

Figure 26. Normalized Effective Height of Top-hat Antenna with Radials,  $N = 12$ , NEC versus Devaney.

**TOP-HAT MONOPOLE ANTENNA**  
 NORMALIZED EFFECTIVE HEIGHT  
 NUMBER OF WIRES = 12, (H/D=200)

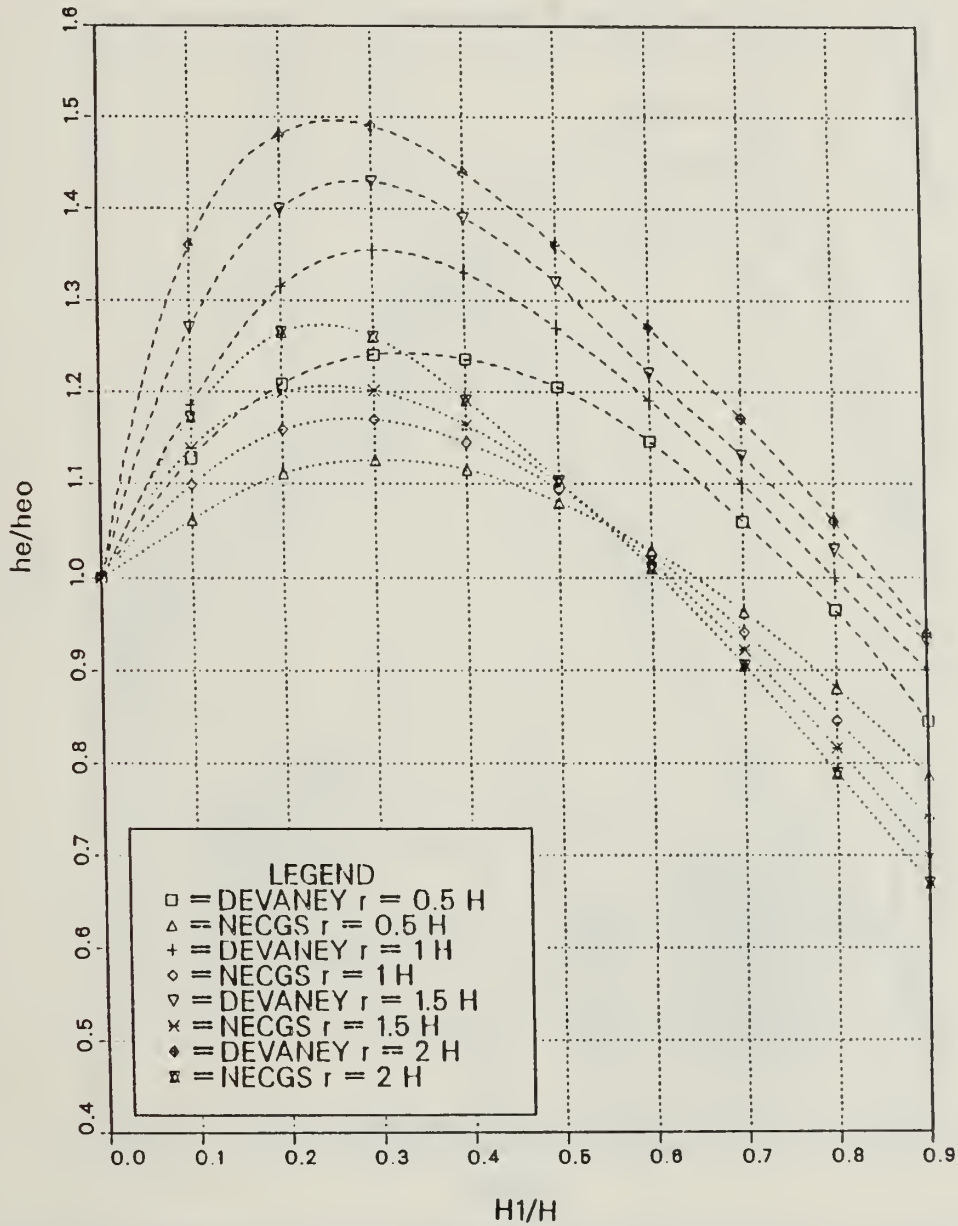

Figure 27. Normalized Effective Height of Top-hat Antenna with Radials,  $N = 12$ , NECGS versus Devaney.

TOP-HAT MONOPOLE ANTENNA  
 NORMALIZED EFFECTIVE HEIGHT  
 NUMBER OF WIRES = 12, (H/D=200)

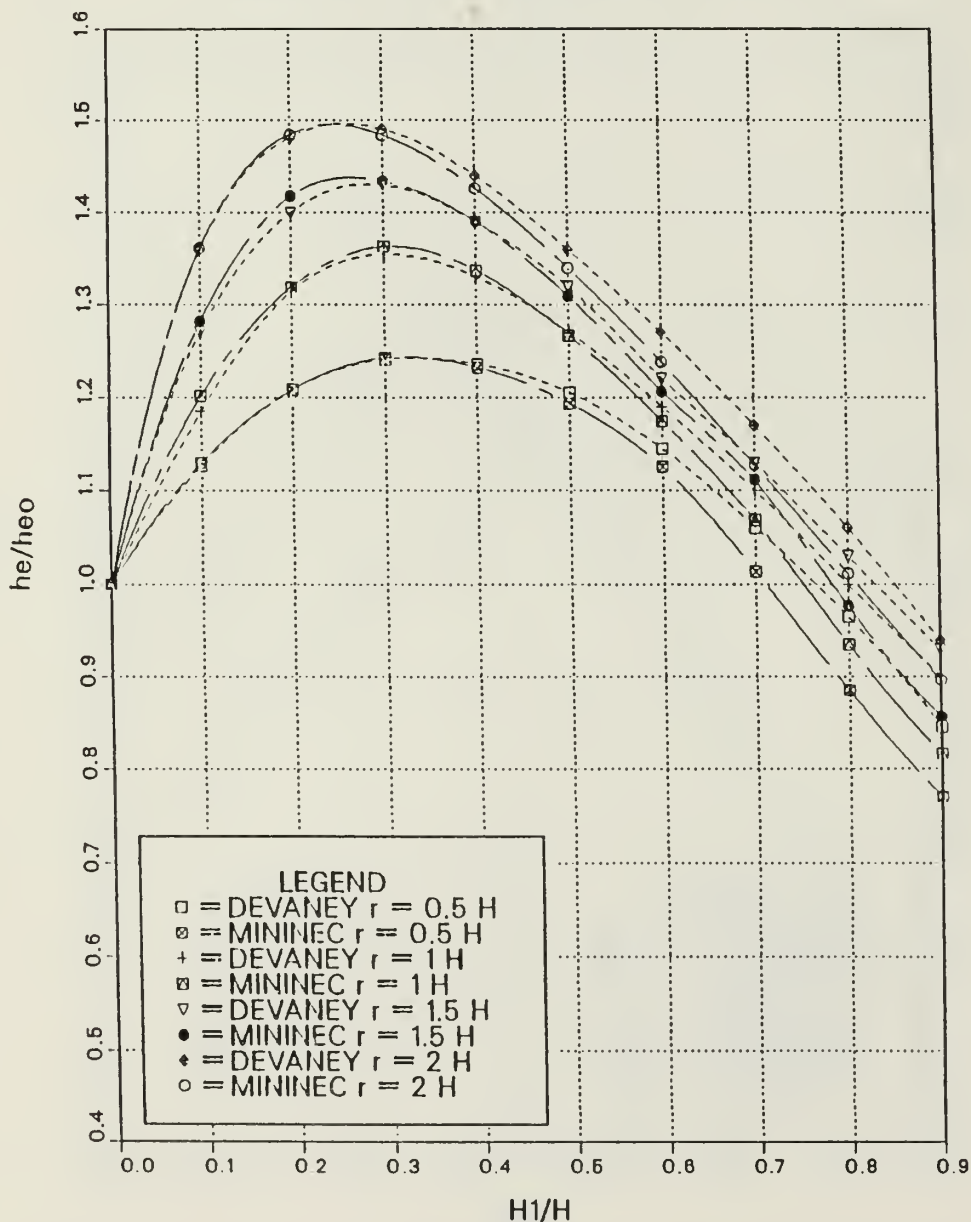

Figure 28. Normalized Effective Height of Top-hat Antenna with Radials,  $N = 12$ , MININEC versus Devaney.

TOP-HAT MONOPOLE ANTENNA  
 NORMALIZED RADIATION RESISTANCE  
 NUMBER OF WIRES = 12, (H/D=200)

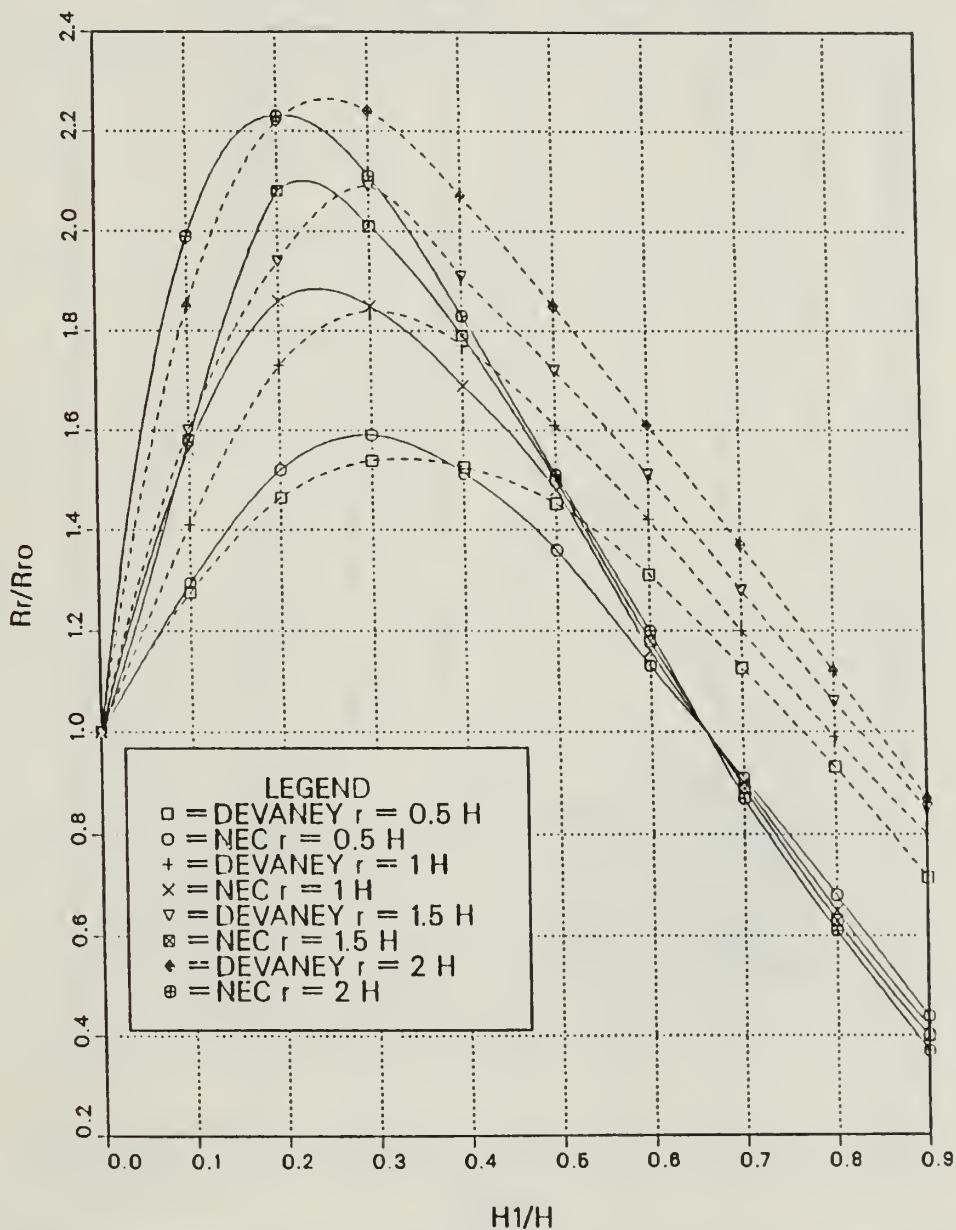

Figure 29. Normalized Radiation Resistance of Top-hat Antenna with Radials,  $N = 12$ , NEC versus Devaney.

TOP-HAT MONOPOLE ANTENNA  
 NORMALIZED RADIATION RESISTANCE  
 NUMBER OF WIRES = 12, (H/D=200)

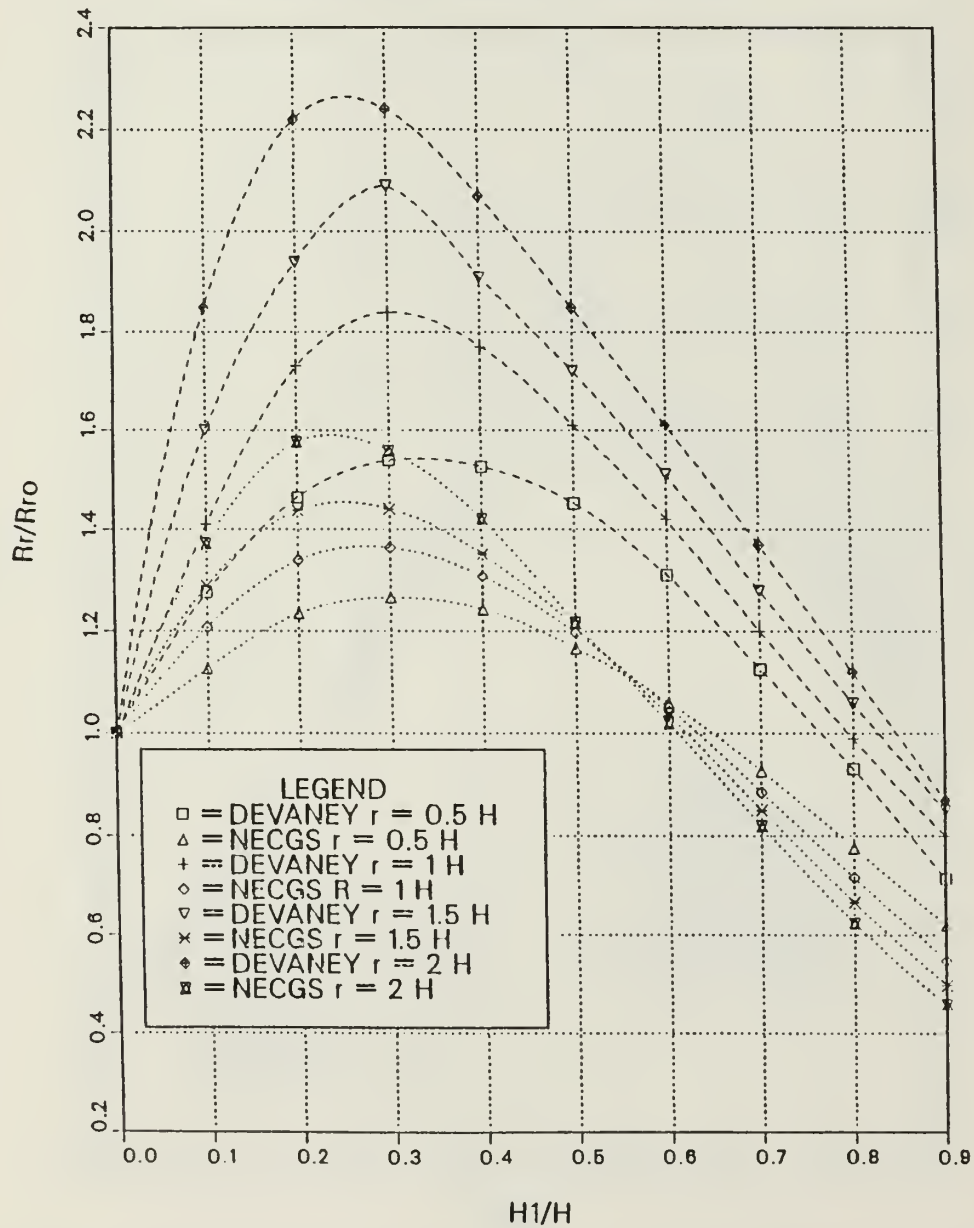

Figure 30. Normalized Radiation Resistance of Top-hat Antenna with Radials,  $N = 12$ , NECGS versus Devaney.

**TOP-HAT MONOPOLE ANTENNA**  
 NORMALIZED RADIATION RESISTANCE  
 NUMBER OF WIRES = 12, ( $H/D = 200$ )

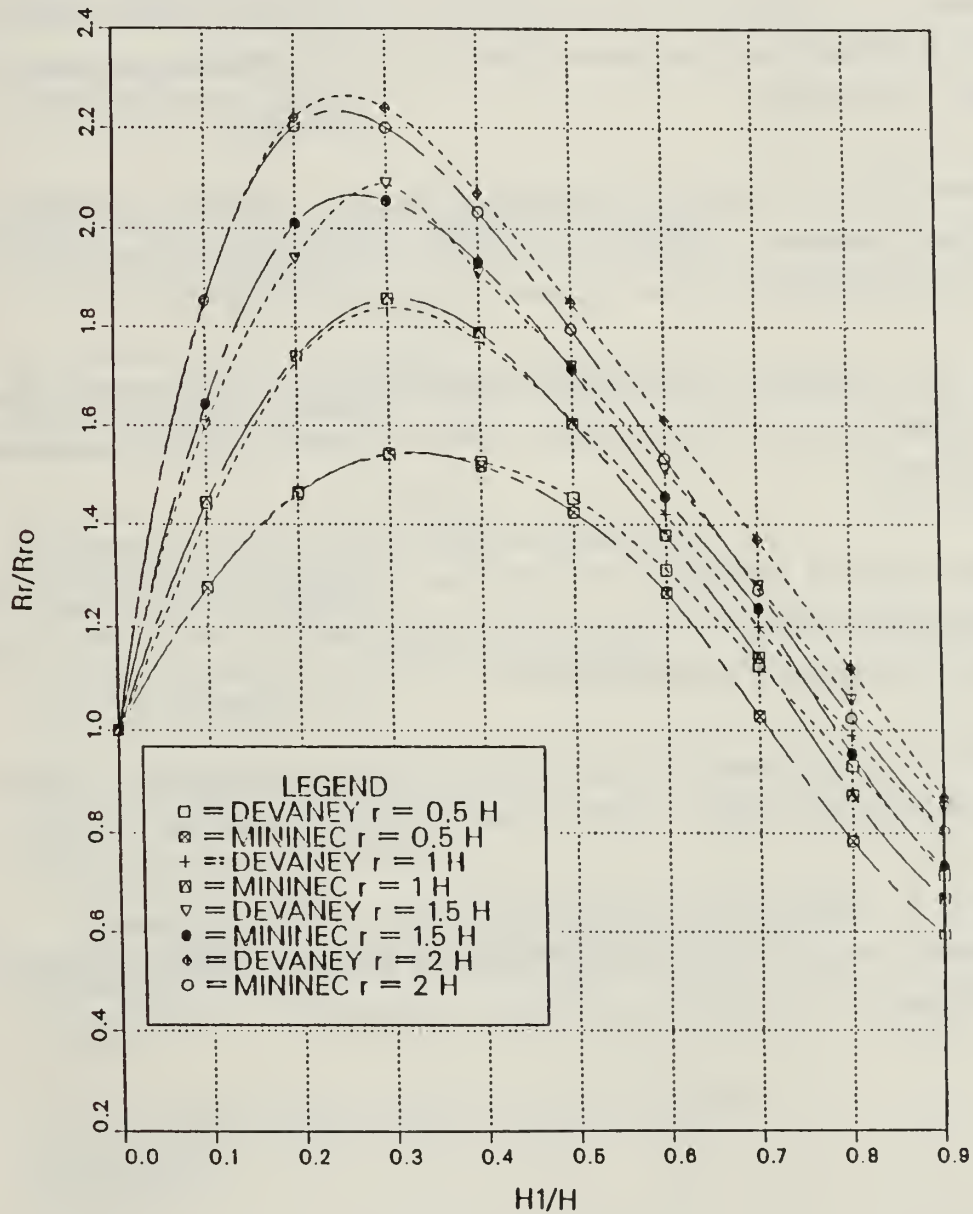

Figure 31. Normalized Radiation Resistance of Top-hat Antenna with Radials,  $N = 12$ , MININEC versus Devaney.

## LIST OF REFERENCES

1. Jasik, H., *Antenna Engineering Handbook*, McGraw-Hill, 1961.
2. Devaney, T. E., Hall, R. F., and Gustafson, W. E., *Low Frequency Top-Loaded Antennas, Research and Development Report*, US Navy Electronics Laboratory, San Diego, 22 June 1966.
3. Mahmud, Riaz, *A Study of LF Top-loaded Monopole Antennas Using Numerical Modeling Techniques, Comparison to Scaled Test Model Measurements*, M. S. Thesis, Naval Postgraduate School, Monterey, California, March 1987.
4. Burke, G. J. and Poggio, A. J., *Numerical Electromagnetics Code (NEC) - Method of Moments, Part III, User's Guide*, Lawrence Livermore National Laboratory, January 1981.
5. Logan, J. C. and Rockway, J. W., *The New MININEC (Version 3), A Mini-Numerical Electromagnetics Code*, Technical Document 938, Naval Ocean System Center, San Diego, Ca., September 1986.
6. Smith, C. E. and Johnson, E. M., "Performance of Short Antennas," *Institute of Radio Engineers Proceedings*, vol. 35, pp. 1026-1038, October 1947.
7. Gangi, A. F., "Characteristics of Electrically Short, Umbrella Top-loaded Antennas," *Institute of Electrical and Electronics Engineers, Transactions Antennas and Propagation*, vol. AP-13, pp. 899-910, November 1965.

## INITIAL DISTRIBUTION LIST

	No. Copies
1. Defense Technical Information Center Cameron Station Alexandria, VA 22304-6145	2
2. Library, Code 0142 Naval Postgraduate School Monterey, CA 93943-5002	2
3. Chairman, Code 62 Department of Electrical and Computer Engineering Naval Postgraduate School Monterey, CA 93943-5000	1
4. Dr. Richard W. Adler, Code 62Ab Department of Electrical and Computer Engineering Naval Postgraduate School Monterey, CA 93943-5000	5
5. Dr. James K. Breakall, Code 62Bk Department of Electrical and Computer Engineering Naval Postgraduate School Monterey, CA 93943-5000	5
6. Director of Research Administration, Code 012 Naval Postgraduate School Monterey, CA 93943	1
7. Chief of the Defense Attache Embassy of the Republic of Indonesia 2020 Massachusetts avenue N.W. Washington D.C. 20036	1
8. Director of Education of the Indonesian Air Force Jl Gatot Subroto no 72 Jakarta-Selatan Indonesia	1
9. Director of Elec.& Comm. of the Indonesian Air Force Jl Gatot Sobroto no. 72 Jakarta-Selatan Indonesia	2
10. Department of Electrical and Computer Engineering University of Indonesia Salemba Raya no. 4, Jakarta Indonesia	1



11. S. Suharsa Padmosutoyo  
Major Indonesian Air Force  
Mabes TNI-AU  
Jalan Gatot Subroto no. 72  
Jakarta, Indonesia

2





Thesis  
P11624 Padmosutoyo  
c.1 NEC, NECGS, and MININEC  
numerical models of LF  
top-hat monopole  
antennas.

Thesis  
P11624 Padmosutoyo  
c.1 NEC, NECGS, and MININEC  
numerical models of LF  
top-hat monopole  
antennas.



NEC, NECGS, and MININEC numerical models



3 2768 000 81831 4

DUDLEY KNOX LIBRARY