



Calhoun: The NPS Institutional Archive
DSpace Repository

Theses and Dissertations

1. Thesis and Dissertation Collection, all items

1980-09

Reduced order models via continued fractions applied to control systems

Porras, William

Monterey, California: U.S. Naval Postgraduate School

<https://hdl.handle.net/10945/28497>

Downloaded from NPS Archive: Calhoun



Calhoun is the Naval Postgraduate School's public access digital repository for research materials and institutional publications created by the NPS community. Calhoun is named for Professor of Mathematics Guy K. Calhoun, NPS's first appointed -- and published -- scholarly author.

Dudley Knox Library / Naval Postgraduate School
411 Dyer Road / 1 University Circle
Monterey, California USA 93943

<http://www.nps.edu/library>



DUDLEY KNOX LIBRARY
MARAL POSTGRADUATE SCHOOL
MORRISVILLE, CALIF 93940

NAVAL POSTGRADUATE SCHOOL

Monterey, California

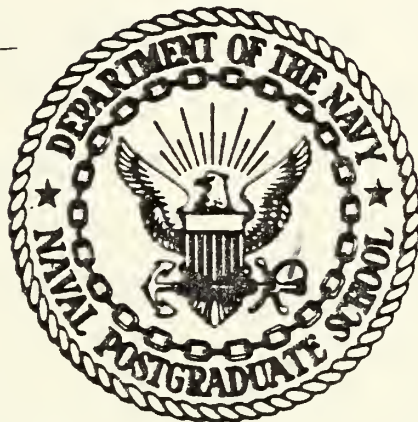

THESIS

REDUCED ORDER MODELS VIA CONTINUED
FRACTIONS APPLIED TO CONTROL SYSTEMS

by

William Porras

September 1980

Thesis Advisor:

M. J. Goldman

Approved for public release; distribution unlimited

T197445

THE UNIVERSITY OF CHICAGO
PHYSICS DEPARTMENT



PHYSICS 351

PROBLEM SET 1

1. A particle of mass m moves in a circular path of radius r with constant speed v . Find the magnitude of the centripetal acceleration.

2. A particle moves in a circular path of radius r with constant speed v . Find the magnitude of the centripetal force.

3. A particle moves in a circular path of radius r with constant speed v . Find the magnitude of the centripetal force.

REPORT DOCUMENTATION PAGE		READ INSTRUCTIONS BEFORE COMPLETING FORM
1. REPORT NUMBER	2. GOVT ACCESSION NO.	3. RECIPIENT'S CATALOG NUMBER
4. TITLE (and Subtitle) Reduced Order Models Via Continued Fractions Applied to Control Systems		5. TYPE OF REPORT & PERIOD COVERED Electrical Engineer Thesis; September 1980
		6. PERFORMING ORG. REPORT NUMBER
7. AUTHOR(s) William Porras		8. CONTRACT OR GRANT NUMBER(s)
9. PERFORMING ORGANIZATION NAME AND ADDRESS Naval Postgraduate School Monterey, California 93940		10. PROGRAM ELEMENT, PROJECT, TASK AREA & WORK UNIT NUMBERS
11. CONTROLLING OFFICE NAME AND ADDRESS Naval Postgraduate School Monterey, California 93940		12. REPORT DATE September 1980
		13. NUMBER OF PAGES 94
14. MONITORING AGENCY NAME & ADDRESS (if different from Controlling Office)		15. SECURITY CLASS. (of this report) UNCLASSIFIED
		15a. DECLASSIFICATION/DOWNGRADING SCHEDULE
16. DISTRIBUTION STATEMENT (of this Report) Approved for public release; distribution unlimited		
17. DISTRIBUTION STATEMENT (of the abstract entered in Block 20, if different from Report)		
18. SUPPLEMENTARY NOTES		
19. KEY WORDS (Continue on reverse side if necessary and identify by block number) ROM(Reduced Order Models); Cauer Form; Control Systems		
20. ABSTRACT (Continue on reverse side if necessary, and identify by block number) Based on the theory of continued fractions, a technique is developed for the reduction of high order multivariable systems. The mathematical basis for which these techniques work is elucidated, and its superiority of the mixed form over any other form of continued fractions is established. The general solution to linear regulator problem is developed and the properties which this solution exhibit are elucidated.		

Approved for public release; distribution unlimited

REDUCED ORDER MODELS VIA CONTINUED FRACTIONS
APPLIED TO CONTROL SYSTEMS

by

William Porras
Lieutenant, Colombian Navy
M.S., Naval Postgraduate School, March 1980

Submitted in partial fulfillment of the
requirements for the degree of

ELECTRICAL ENGINEER

from the

NAVAL POSTGRADUATE SCHOOL
September 1980

A

Dean of Science and Engineering

ABSTRACT

Based on the theory of continued fractions, a technique is developed for the reduction of high order multivariable systems. The mathematical basis for which these techniques work is elucidated, and its superiority of the mixed form over any other form of continued fractions is established. The general solution to linear regulator problem is developed and the properties which this solution exhibit are elucidated.

TABLE OF CONTENTS

I.	INTRODUCTION- - - - -	9
II.	MULTIVARIABLE SYSTEM REDUCTION VIA THE CAUER FORMS - - - - -	11
	A. THREE MATRIX CAUER FORM - - - - -	11
	B. STATE SPACE FORMULATION FOR THREE CAUER FORMS - - - - -	14
	C. APPROXIMATION BY THREE CAUER FORMS- - - - -	28
	1. Cauer First Form- - - - -	32
	2. Cauer Second Form - - - - -	33
	3. Cauer Mixed Form- - - - -	34
	D. TRUNCATION OF THE CAUER MIXED FORM THE BEST APPROXIMATION IN A DEFINITE MATHEMATICAL SENSE FOR MULTIVARIABLE SYSTEM REDUCTION- - - - -	36
	E. SIMPLIFYING A MATRIX TRANSFER FUNCTION- - - - -	41
	F. NUMERICAL EXAMPLES AND GRAPHICAL COMPARISON OF THE THREE CAUER FORMS - - - - -	46
	1. Example 2.1 - - - - -	46
	2. Example 2.2 - - - - -	50
	a. Cauer Matrix First Form - - - - -	52
	b. Cauer Matrix Second Form- - - - -	54
	c. Cauer Matrix Mixed Form - - - - -	57
III.	DERIVATION OF LOWER ORDER SYSTEM FOR THE LINEAR REGULATOR PROBLEM VIA CAUER FORM - - - - -	61
	A. LINEAR REGULATOR SYSTEM - - - - -	61
	B. THE STATE VARIABLE REPRESENTATION BY CAUER SECOND FORM AND ITS OPTIMAL SOLUTION- - - - -	62
	C. THE REDUCED ORDER SOLUTION- - - - -	68

1. Example 3.1 - - - - -	70
2. Example 3.2 - - - - -	74
IV. CONCLUSIONS AND RECOMMENDATIONS - - - - -	86
APPENDIX A- - - - -	88
LIST OF REFERENCES- - - - -	91
INITIAL DISTRIBUTION LIST - - - - -	93

LIST OF FIGURES

1.	Feedback and Feedforward Controls- - - - -	15
2.	General Matrix Representation of a nth Order System by Cauer Mixed Form with Two Inputs Two Outputs. (n even) - - - - -	16
3.	Matrix Representation of a nth/2 Order System by Cauer First Form with Two Inputs Two Outputs. (n even)- - - - -	17
4.	Matrix Representation of a nth/2 Order System by Cauer Second Form with Two Inputs Two Outputs. (n even)- - - - -	18
5.	Block Diagram for a Typical Feedback System with a Minor Feedforward Loop with Two Inputs and Two Outputs. - - - - -	29
6.	Block Diagram Representation of a Continued Fraction Expansion.- - - - -	31
7.	Simulation Diagram for Fourth Order System with m=2 for Cauer Matrix Mixed Form.- - - - -	45
8.	Simulation Diagram for Fourth Order System with m=2 for Cauer Matrix First Form.- - - - -	47
9.	Simulation Diagram for Fourth Order System with m=2 for Cauer Matrix Second Form. - - - - -	48
10.	Outputs for the Original Fourth Order System and Reduced Second Order System in the Three Cauer Forms. (a) Output One. (b) Output Two. - - - - -	51
11.	Outputs for the Original Sixth Order System and Reduced Second Order System by Cauer First Form. (a) Output One. (b) Output Two. - - - - -	55
12.	Outputs for the Original Sixth Order System and Reduced Second Order System by Cauer Second Form. (a) Output One. (b) Output Two. - - - - -	58

13.	Outputs for the Original Sixth Order System and Reduced Fourth Order System by Cauer Mixed Form.	
	(a) Output One.	
	(b) Output Two.- - - - -	59
14.	Linear Regulator System.- - - - -	62
15.	Linear Regulator in Cauer Form. - - - - -	65
16.	Reduced Linear Regulator in Cauer Form. - - - - -	67
17.	Example 3.1 Step Response Optimal and Reduced Linear Regulator- - - - -	75
18.	Example 3.1 Near Optimal Solution. Optimal and Suboptimal Control Laws.- - - - -	76
19.	Example 3.1 Step Response Optimal and Suboptimal Linear Regulator.- - - - -	77
20.	Block Diagram Optimal Control of a Nuclear Reactor - - - - -	79
21.	Example 3.2 Step Response Nuclear Reactor Original and Reduced Optimal Systems. - - - - -	85

ACKNOWLEDGMENT

The author gratefully acknowledges the Colombian and U. S. Navies for the opportunity to attend the Naval Postgraduate School and for the support received during his studies and would like to especially thank Admiral A. Diaz and Vice-Admiral G. Uribe of the Colombian Navy.

The author is indebted first and foremost to his advisors, Dr. M. J. Goldman and Professor A. Gerba, Jr., for their wise and thoughtful advice involving many of the topics in this thesis.

On a more personal note, not a chapter of this thesis, which represents the culmination of two years of studies, could have been written or finished without the complete patience and support of my wife Linda and my entire family who allowed me the time necessary to undertake this work.

I. INTRODUCTION

The capability of obtaining simplified mathematical models for use in the analysis of high order dynamic systems has traditionally relied on the experience and ingenuity of the analyst. Usually, these efforts have been achieved using both frequency and time domain techniques.

In dealing with the problem stated above, and through the use of theory of continued fraction, this research has found a series of properties applicable to reduction of multivariable systems, lower order observers and derivations of lower order systems for the linear regulator problem. The relationships developed, show applications in areas where the high order systems are impractical or undesirable to use due to their complexity or difficulty of implementation.

In Chapter II reduced order models of multivariable systems for the first, second and mixed Cauer forms are developed. Techniques for approximating a high order linear time-invariant system with various inputs and various outputs by a reduced order model, have been suggested by Chen [1], Meier, L and Luenberger [2], L. S. Shieh and Y. J Wei [3], M. R. Calfe and M. Healey [4], L. S. Shieh, J. M. Navarro and R. Yates [5], D. A. Wilson [6], L. S. Shieh and F. F. Gaudiano [7].

Most of these methods for reducing high order linear systems are based on the following principles:

1. The low performance terms can be discarded and the high performance terms should be retained.
2. Linear transformation to obtain matrix diagonalization where certain diagonal elements can be discarded.
3. The sum of squares of the errors between the responses of the real system and those of the approximate model at the sampling instant is minimized in order to obtain the parameters of the approximate model.

In a recent paper, Chen [1] proposed a reduction of multivariable control systems by means of matrix second Cauer form of continued fractions. Through the method, a simplified model is obtained by keeping the first several significant matrix quotients and discarding the others. However, the technique (due to the nature of the Cauer second form), provides satisfactory results in the steady state region only. Furthermore, M. R. Calfe and M. Healey [4], have shown that the method does not guarantee the reduced model to be stable.

In Chapter III derivation of lower order system for the linear regulator problem via Cauer form is obtained and also a near optimal solution for the original system can be found through a reduced system.

II. MULTIVARIABLE SYSTEMS REDUCTION VIA THE CAUER FORM

A. THREE MATRIX CAUER FORMS

L.S. Shieh and F.F. Gaudiano [7] have shown that in terms of multivariable systems the quotients in the three Cauer forms are replaced by matrix quotients and the division in the continued fraction is replaced by matrix inversion. The first matrix Cauer form is

$$T(s) = [H'_1 s + [H'_2 + [H'_3 s + [H'_4 + [\dots]^{-1}]^{-1}]^{-1}]^{-1} \quad (1)$$

the second matrix Cauer form is

$$T(s) = [H_1 + [H_2 \frac{1}{s} + [H_3 + [H_4 \frac{1}{s} + [\dots]^{-1}]^{-1}]^{-1}]^{-1} \quad (2)$$

and the mixed matrix Cauer form is

$$T(s) = [K_1 + K'_1 s + [K_2 \frac{1}{s} + K'_2 + [K_3 + K'_3 s + K_4 \frac{1}{s} + K'_4 + [\dots]^{-1}]^{-1}]^{-1}]^{-1} \quad (3)$$

where H'_1 , H_1 , K_1 , and K'_1 are constant $m \times m$ matrix quotients obtained respectively from the matrix Routh's array and the generalized Routh's algorithm shown in equations (4a) and (4b).

$$\begin{array}{ccc}
H_1 = A_{11} A_{21}^{-1} & \begin{array}{l} \swarrow \\ \searrow \end{array} \begin{array}{l} A_{11} \quad A_{12} \quad \dots \quad A_{1n} \\ A_{21} \quad A_{22} \quad \dots \quad A_{2n} \end{array} & A_{1,n+1} \begin{array}{l} \swarrow \\ \searrow \end{array} & H'_1 = A_{1,n+1} A_{2n}^{-1} \\
H_2 = A_{21} A_{31}^{-1} & \begin{array}{l} \swarrow \\ \searrow \end{array} \begin{array}{l} A_{21} \quad A_{22} \quad \dots \quad A_{2n} \\ A_{31} \quad A_{32} \quad \dots \quad A_{3,n-1} \end{array} & & H'_2 = A_{2,n} A_{3,n-1}^{-1} \\
H_3 = A_{31} A_{41}^{-1} & \begin{array}{l} \swarrow \\ \searrow \end{array} \begin{array}{l} A_{31} \quad A_{32} \quad \dots \quad A_{3,n-1} \\ A_{41} \quad A_{42} \quad \dots \quad A_{4,n-2} \end{array} & & H'_3 = A_{3,n-1} A_{4,n-2}^{-1} \\
\vdots & \vdots & & \vdots
\end{array}$$

$$\begin{array}{ccc}
H_{n-1} = A_{n-1,1} A_{n,1}^{-1} & \begin{array}{l} \swarrow \\ \searrow \end{array} \begin{array}{l} A_{n-1,1} \quad A_{n-1,2} \quad A_{n-1,3} \\ A_{n,1} \quad A_{n,2} \end{array} & \begin{array}{l} \swarrow \\ \searrow \end{array} & H'_{n-1} = A_{n-1,3} A_{n,2}^{-1} \\
H_n = A_{n,1} A_{n+1,1}^{-1} & \begin{array}{l} \swarrow \\ \searrow \end{array} \begin{array}{l} A_{n,1} \quad A_{n,2} \\ A_{n+1,1} \end{array} & \begin{array}{l} \swarrow \\ \searrow \end{array} & H'_n = A_{n,2} A_{n+1,1}^{-1}
\end{array}$$

(4a)

$$\begin{array}{ccc}
K_1 = A_{11} A_{21}^{-1} & \begin{array}{l} \swarrow \\ \searrow \end{array} \begin{array}{l} A_{11} \quad A_{12} \quad \dots \quad A_{1n} \quad A_{1,n+1} \\ A_{21} \quad A_{22} \quad \dots \quad A_{2n} \end{array} & \begin{array}{l} \swarrow \\ \searrow \end{array} & K'_1 = A_{1,n-1} A_{2n}^{-1} \\
K_2 = A_{21} A_{31}^{-1} & \begin{array}{l} \swarrow \\ \searrow \end{array} \begin{array}{l} A_{21} \quad A_{22} \quad \dots \quad A_{2n} \\ A_{31} \quad A_{32} \quad \dots \quad A_{3,n-1} \end{array} & \begin{array}{l} \swarrow \\ \searrow \end{array} & K'_2 = A_{2,n} A_{3,n-1}^{-1} \\
K_3 = A_{31} A_{41}^{-1} & \begin{array}{l} \swarrow \\ \searrow \end{array} \begin{array}{l} A_{31} \quad A_{32} \quad \dots \quad A_{3,n-1} \\ A_{41} \quad A_{42} \quad \dots \quad A_{4,n-2} \end{array} & \begin{array}{l} \swarrow \\ \searrow \end{array} & K'_3 = A_{3,n-1} A_{4,n-2}^{-1} \\
\vdots & \vdots & & \vdots
\end{array}$$

$$\begin{array}{ccc}
: & : & : \\
K_{n-1} = A_{n-1}, & {}_1A_{n-1,1}^{-1} < \begin{array}{c} A_{n-1,1} \ A_{n-1,2} \cdots A_{n-1,3} \\ A_{n,1} \ A_{n,2} \\ A_{n+1,1} \end{array} > & K'_{n-1} = A_{n-1,3} A_{n-2}^{-1} \\
K_n = A_n, & {}_1A_{n+1,1}^{-1} < \begin{array}{c} A_{n,1} \ A_{n,2} \\ A_{n+1,1} \end{array} > & K'_n = A_{n,2} A_{n+1,1}^{-1}
\end{array}
\tag{4b}$$

where the elements of the first and second rows of equations (4a) and (4b) are the matrix coefficients of the system given in equation (5).

$$T(s) = [A_{2,n} S^{n-1} + A_{2,n-1} S^{n-2} + \dots A_{23} S^2 + A_{22} S + A_{21}] x \tag{5}$$

$$[A_{1,n+1} S^n + A_{1,n} S^{n-1} + \dots A_{13} S^2 + A_{12} S + A_{11}]^{-1}$$

The elements of the third, fourth and subsequent rows in (4a) and (4b) are evaluated respectively for the three Caueer forms by the formulation shown in (6a) through (6c).

$$\left[\begin{array}{ll}
H_p = A_{p,n+2-p} A_p^{-1} + 1, 1 & p = 1, 2, 3, \dots, n \\
A_{j,i} = A_{j-2, i+1} - H_{j-2} A_{j-1, i} & j = 3, 4, \dots, 2n \\
\det A_{p+1,1} \neq 0 & i = n+1, n, n-1, \dots, 1
\end{array} \right] \tag{6a}$$

$$\left[\begin{array}{l} H_p = A_{p,1} \bar{A}_p^{-1} + 1, 1 \quad p=1, 2, 3, \dots, 2n \\ A_{j,i} = A_{j-2, i+1} - H_{j-2} A_{j-1, i+1} \quad j=3, 4, \dots, 2n \\ \det A_{p+1,1} \neq 0 \quad i=1, 2, 3, \dots, n \end{array} \right] \quad (6b)$$

$$\left[\begin{array}{l} K_p = A_{p,1} \bar{A}_{p+1}^{-1} \quad p=1, 2, 3, \dots, n \\ K_p = A_{p, n+2-p} \bar{A}_{p+1}^{-1}, n+1-p \quad j=3, 4, \dots, n+1 \\ A_{j,i} = A_{j-2, i+1} - K_{j-2} A_{j-1, i+1} - K_{j-2} A_{j=1, i} \quad i=1, 2, 3, \dots \end{array} \right] \quad (6c)$$

It is important to note that since the Cauer first and second forms are special cases of the Cauer mixed form, their formulation in (6a) and (6b) can be derived directly from (6c), by letting all k_p 's or all K_p 's equal to zero respectively.

B. STATE SPACE FORMULATION FOR THREE CAUER FORMS

The Cauer Mixed Form - Consider a typical feedback system with a minor feed forward loop as shown in Figure 1. The overall transfer function is given by:

$$T(s) = \frac{Y(s)}{U(s)} = [G + F][I + (G + F)H]^{-1}. \quad (7)$$

Equation (7) can be rewritten as a mixed matrix of continued fractions

$$T(s) = [H + [F + G]^{-1}]^{-1}, \quad (8)$$

where

$$\left. \begin{aligned} H &= K_1 + K_1' S \\ F &= K_2 \frac{1}{S} + K_2' \end{aligned} \right\} \quad (9)$$

I = Identity Matrix

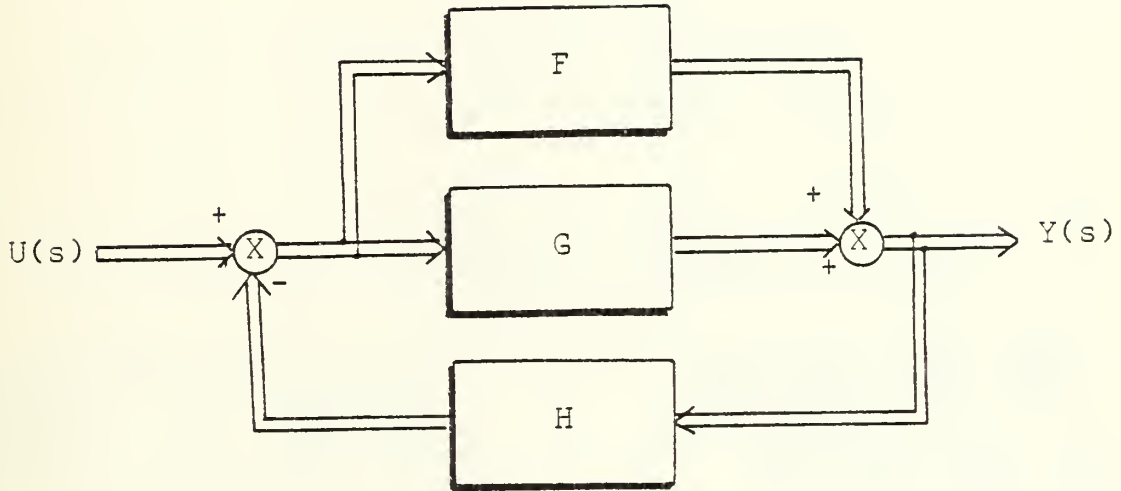

Figure 1. Feedback and Feedforward controls.

If the subsystem G is expanded again, equation (3) is obtained. This equation can be represented by the block diagram shown in Figure 2. Where a 2 inputs-2 outputs nth order system is shown. Again, it is important to note that if all K_i 's go to zero in Figure 2 the block diagram representation of Caueer matrix first form nth/2 order system as shown in Figure 3 will automatically be obtained. In a similar fashion if the k_i 's go to zero, the block diagram representation of Caueer matrix second form nth/2 order system as shown in Figure 4 is obtained.

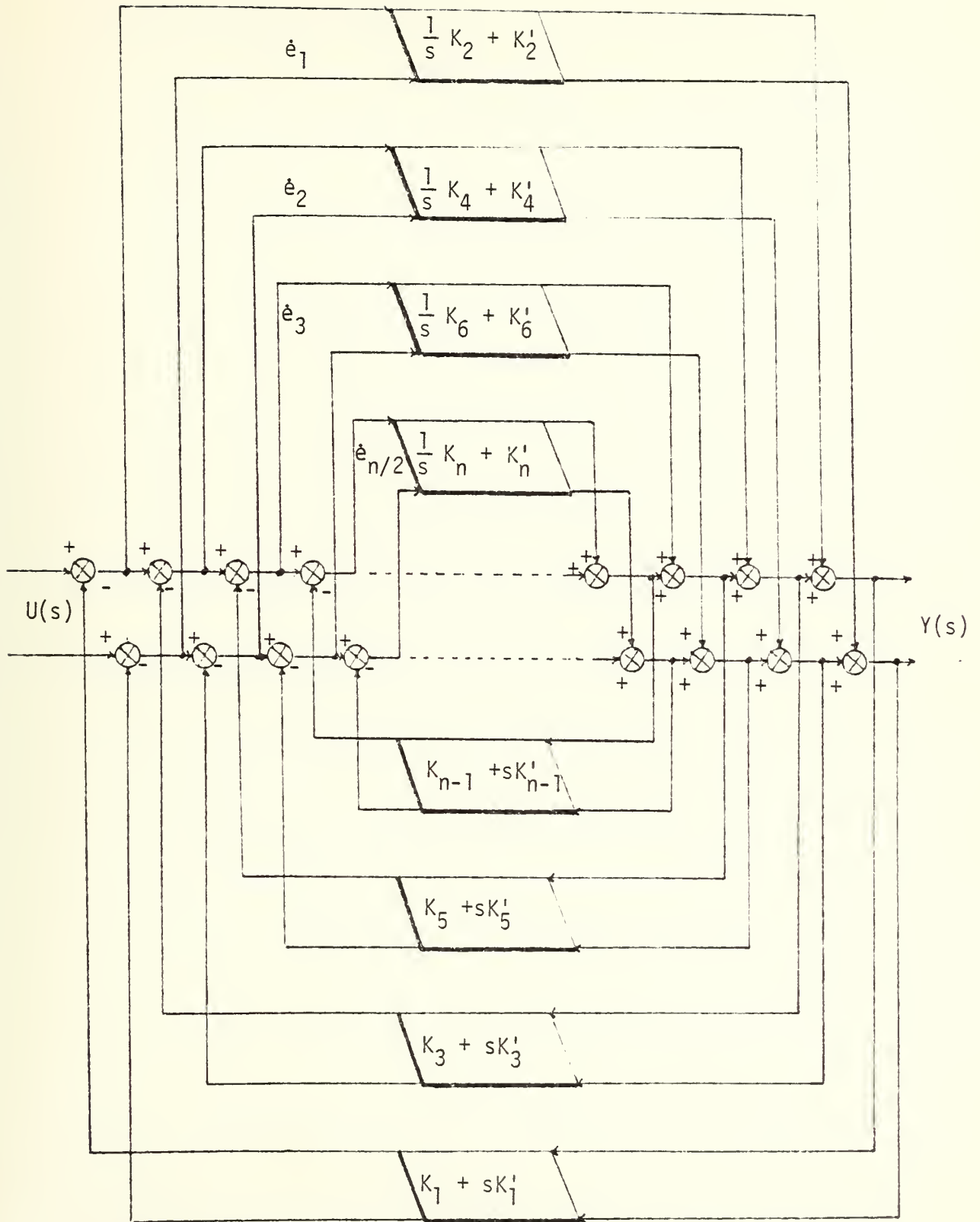

Figure 2. General Matrix representation of a nth order system by Causer mixed form with two inputs two outputs. (n even)

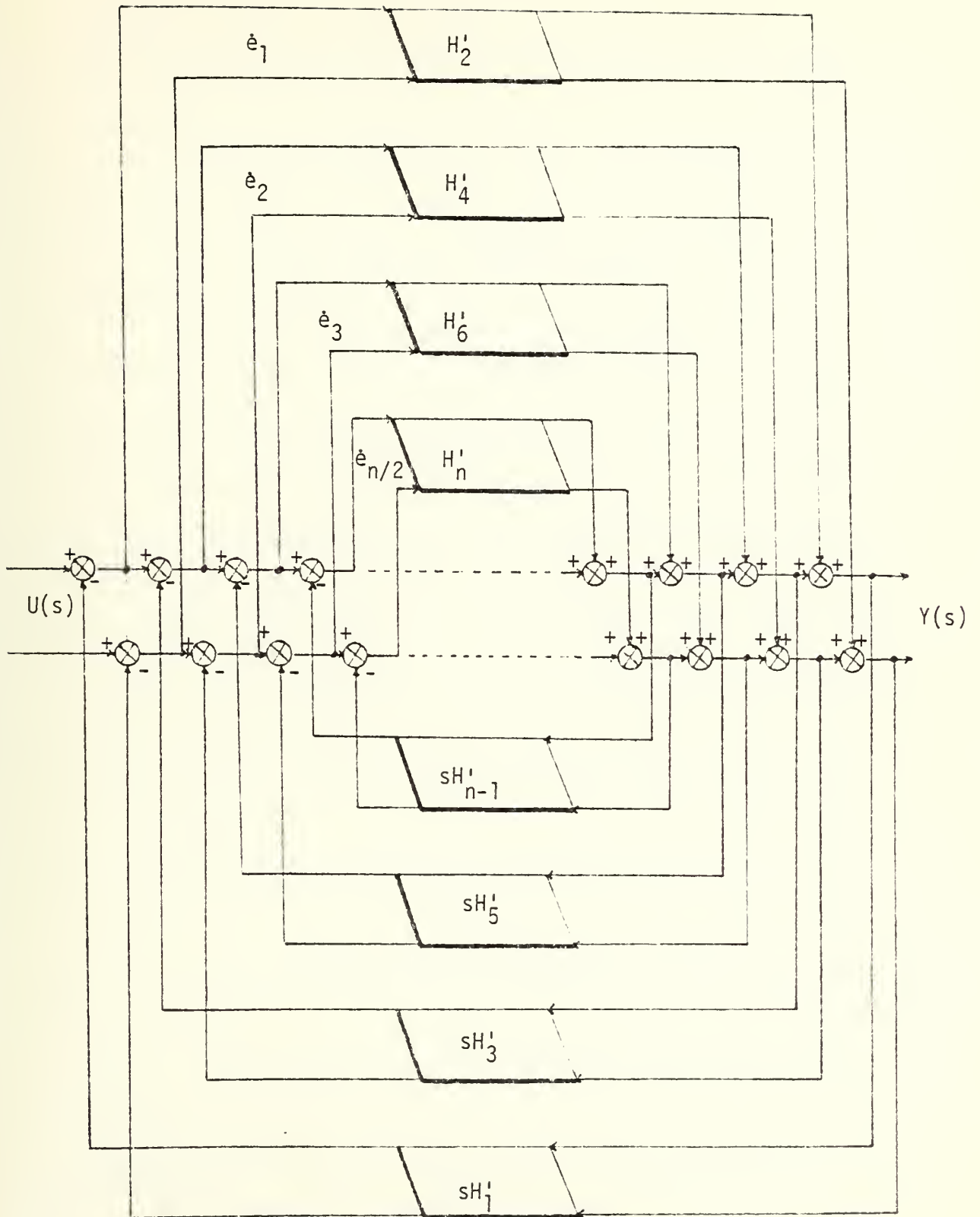

Figure 3. Matrix representation of a n th/2 order system by Causer first form with two inputs two outputs. (n even)

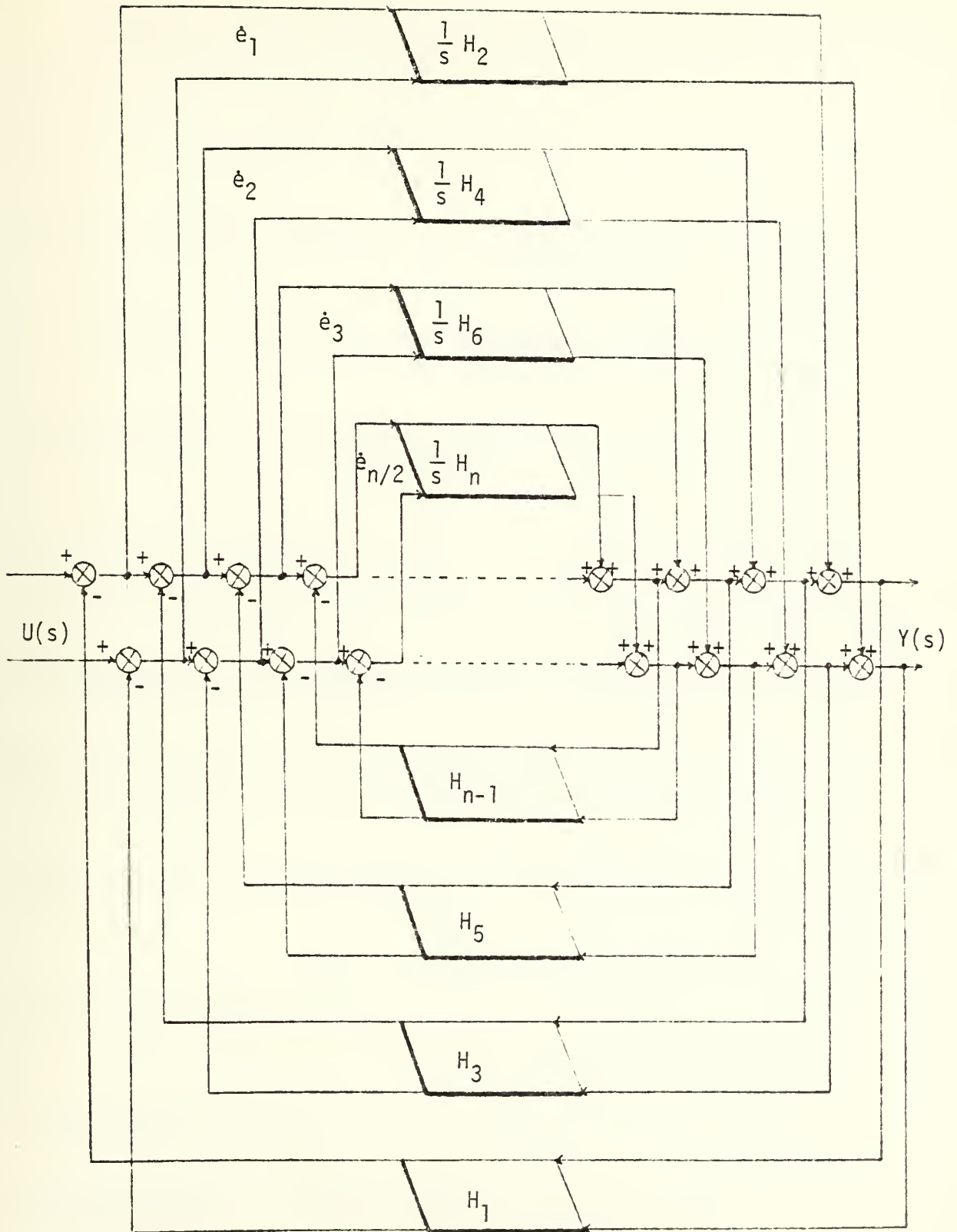

Figure 4. Matrix representation of a $n/2$ order system by Causer second form with two inputs two outputs. (n even)

Going back to Figure 2 and allowing e_i to be the state variable vector (same order as the matrix K or K'), the equations in the time domain can be written as follows:

$$\begin{aligned}
& K'_1 K'_2 \ddot{e}_1 + K'_1 K'_4 \ddot{e}_2 + K'_1 K'_6 \ddot{e}_3 + \dots + K'_1 K'_n \ddot{e}_{n/2} = \\
& -(I + K'_1 K'_2 + K'_1 K'_2) \dot{e}_1 - (K'_1 K'_4 + K'_1 K'_4) \dot{e}_2 - (K'_1 K'_6 + K'_1 K'_6) \dot{e}_3 - \dots \\
& - (K'_1 K'_n + K'_1 K'_n) \dot{e}_{n/2} - K_1 K_2 e_1 - K_1 K_4 e_2 - \dots - K_1 K_n e_{n/2} + IU
\end{aligned} \tag{10}$$

$$\begin{aligned}
& K'_1 K'_2 \ddot{e}_1 + (K'_1 + K'_3) K'_4 \ddot{e}_2 + (K'_1 + K'_3) K'_6 \ddot{e}_3 + \dots + (K'_1 + K'_3) K'_n \ddot{e}_{n/2} = \\
& -(K_1 K'_2 + K'_1 K_2) \dot{e}_1 - [(I + K'_1 + K'_3) K_4 + (K_1 + K_3) K'_4] \dot{e}_2 - \\
& [(K'_1 + K'_3) K_6 + (K_1 + K_3) K'_6] \dot{e}_3 - \dots - [(K'_1 + K'_3) K_n + (K_1 + K_3) K'_n] \dot{e}_{n/2} \\
& - K_1 K_2 e_1 - (K_1 + K_3) K_4 e_2 - (K_1 + K_3) K_6 - \dots - (K_1 + K_3) K_n e_{n/2} + IU
\end{aligned} \tag{11}$$

$$\begin{aligned}
& K'_1 K'_2 \ddot{e}_1 + (K'_1 + K'_3) K'_4 \ddot{e}_2 + (K'_1 + K'_3 + K'_5) K'_6 \ddot{e}_3 + \dots + (K'_1 + K'_3 + K'_5) K'_n \ddot{e}_{n/2} = \\
& -(K_1 K'_2 + K'_1 K_2) \dot{e}_1 - [(K'_1 + K'_3) K_4 + (K_1 + K_3) K'_4] \dot{e}_2 - [I + (K'_1 + K'_3 + K'_5) K_6 + \\
& (K_1 + K_3 + K_5) K'_6] \dot{e}_3 - \dots - [(K'_1 + K'_3 + K'_5) K_n + (K_1 + K_3 + K_5) K'_n] \dot{e}_{n/2} \\
& - K_1 K_2 e_1 - (K_1 + K_3) K_4 e_2 - (K_1 + K_3 + K_5) K_6 e_3 - \dots - (K_1 + K_3 + K_5) K_n e_{n/2} + IU
\end{aligned} \tag{12}$$

$$\begin{aligned}
& K'_1 K'_2 \ddot{e}_1 + (K'_1 + K'_3) K'_4 \ddot{e}_2 + (K'_1 + K'_3 + K'_5) K'_6 \ddot{e}_3 + \dots \\
& + (K'_1 + K'_3 + K'_5 + \dots + K'_{n-1}) K'_n e_{n/2} = \\
& - (K'_1 K'_2 + K'_1 K'_2) \dot{e}_1 - [(K'_1 + K'_3) K'_4 + (K'_1 + K'_3) K'_4] \dot{e}_2 - \\
& [(K'_1 + K'_3 + K'_5) K'_6 + (K'_1 + K'_3 + K'_5) K'_6] \dot{e}_3 - \dots - \\
& [I + (K'_1 + K'_3 + K'_5 + \dots + K'_{n-1}) K'_n + (K'_1 + K'_3 + K'_5 + \dots + K'_{n-1}) K'_n] \dot{e}_{n/2} \\
& - K'_1 K'_2 e_1 - (K'_1 + K'_3) K'_4 e_2 - (K'_1 + K'_3 + K'_5) K'_6 e_3 - \dots - \\
& (K'_1 + K'_3 + K'_5 + \dots + K'_{n-1}) K'_n e_{n/2} + IU
\end{aligned} \tag{13}$$

and

$$Y = K'_2 e_1 + K'_2 \dot{e}_1 + K'_4 e_2 + K'_4 \dot{e}_2 + \dots + K'_n e_{n/2} + K'_n \dot{e}_{n/2}. \tag{14}$$

where U and Y are the input and output variables of the system respectively and I is the Identity Matrix. From Equations (10), (11), (12), (13), and (14) the following corresponding matrix formulation can be obtained:

$$[A_1] \ddot{E} = -[A_2] \dot{E} - [A_3] E + [B] U, \tag{15}$$

and

$$Y = [C_1]^T E + [C_2]^T \dot{E}. \tag{16}$$

where

$$[A_1] = \begin{bmatrix} K'_1 K'_2 & K'_1 K'_4 & K'_1 K'_6 \dots \dots \dots K'_1 K'_n \\ K'_1 K'_2 & (K'_1 + K'_3) K'_4 & (K'_1 + K'_3) K'_6 \dots \dots \dots (K'_1 + K'_3) K'_n \\ K'_1 K'_2 & (K'_1 + K'_3) K'_4 & (K'_1 + K'_3 + K'_5) K'_6 \dots \dots \dots (K'_1 + K'_3 + K'_5) K'_n \\ \vdots & \vdots & \vdots & \vdots & \vdots \\ \vdots & \vdots & \vdots & \vdots & \vdots \\ K'_1 K'_2 & (K'_1 + K'_3) K'_4 & (K'_1 + K'_3 + K'_5) K'_6 \dots \dots \dots (K'_1 + K'_3 + \dots + K'_{n-1}) K'_n \end{bmatrix} \quad (17)$$

$$[\ddot{E}] = \begin{bmatrix} \ddot{e}_1 \\ \ddot{e}_2 \\ \ddot{e}_3 \\ \vdots \\ \vdots \\ \vdots \\ \ddot{e}_{n/2} \end{bmatrix} \quad (18)$$

$$[A_2] = \begin{bmatrix} I + K'_1 K'_2 + K_1 K'_2 & K_1 K'_4 + K'_1 K_4 \dots \\ K_1 K'_2 + K'_1 K_2 & I + (K_1 + K_3) K'_4 + (K'_1 + K'_3) K_4 \dots \\ K_1 K'_2 + K'_1 K_2 & (K_1 + K_3) K'_4 + (K'_1 + K'_3) K_4 \dots \\ \vdots & \vdots \\ K_1 K'_2 + K'_1 K_2 & (K_1 + K_3) K'_4 + (K'_1 + K'_3) K_4 \dots \\ \dots K_1 K'_6 + K'_1 K_6 \dots \\ \dots (K_1 + K_3) K'_6 + (K'_1 + K'_3) K_6 \dots \\ \dots I + (K_1 + K_3 + K_5) K'_6 + (K'_1 + K'_3 + K'_5) K_6 \dots \\ \vdots & \vdots \\ \dots (K_1 + K_3 + K_5) K'_6 + (K'_1 + K'_3 + K'_5) K_6 \dots \end{bmatrix}$$

$$\begin{array}{c}
 \vdots \\
 \vdots \\
 \dots K_1 K'_n + K'_1 K_n \\
 \dots (K'_1 + K'_3) K_n + (K_1 + K_3) K'_n \\
 \dots (K'_1 + K'_3 + K'_5) K_n + (K_1 + K_3 + K_5) K'_n \\
 \vdots \\
 \vdots \\
 \dots I + (K'_1 + K'_3 + K'_5 + \dots + K'_{n-1}) K_n + (K_1 + K_3 + K_5 + \dots + K_{n-1}) K'_n
 \end{array}
 \left. \vphantom{\begin{array}{c} \vdots \\ \vdots \\ \dots K_1 K'_n + K'_1 K_n \\ \dots (K'_1 + K'_3) K_n + (K_1 + K_3) K'_n \\ \dots (K'_1 + K'_3 + K'_5) K_n + (K_1 + K_3 + K_5) K'_n \\ \vdots \\ \vdots \\ \dots I + (K'_1 + K'_3 + K'_5 + \dots + K'_{n-1}) K_n + (K_1 + K_3 + K_5 + \dots + K_{n-1}) K'_n \end{array}} \right]$$

(19)

$$[\dot{E}] = \begin{bmatrix} \dot{e}_1 \\ \dot{e}_2 \\ \dot{e}_3 \\ \vdots \\ \vdots \\ \dot{e}_{n/2} \end{bmatrix}$$

(20)

$$[A_3] = \begin{bmatrix} K_1 K_2 & K_1 K_4 & K_1 K_6 & \dots & K_1 K_n \\ K_1 K_2 & (K_1 + K_3) K_4 & (K_1 + K_3) K_6 & \dots & (K_1 + K_3) K_n \\ K_1 K_2 & (K_1 + K_3) K_4 & (K_1 + K_3 + K_5) K_6 & \dots & (K_1 + K_3 + K_5) K_n \\ \vdots & \vdots & \vdots & & \vdots \\ \vdots & \vdots & \vdots & & \vdots \\ K_1 K_2 & (K_1 + K_3) K_4 & (K_1 + K_3 + K_5) K_6 & \dots & (K_1 + K_3 + K_5 + \dots + K_{n-1}) K_n \end{bmatrix}$$

(21)

$$[E] = \begin{bmatrix} e_1 \\ e_2 \\ e_3 \\ \vdots \\ \vdots \\ e_{n/2} \end{bmatrix} \quad (22)$$

$$[B] = \begin{bmatrix} I \\ I \\ I \\ \vdots \\ \vdots \\ I \end{bmatrix} \quad (23)$$

$$[C_1]^T = [K_2 \ K_4 \ K_6 \ \dots \ K_n], \quad (24)$$

$$[C_2]^T = [K'_2 \ K'_4 \ K'_6 \ \dots \ K'_n], \quad (25)$$

$$\ddot{e}_1 = \begin{bmatrix} \ddot{x}_1 \\ \ddot{x}_2 \\ \vdots \\ \vdots \\ \ddot{x}_m \end{bmatrix} \quad \ddot{e}_2 = \begin{bmatrix} \ddot{x}_{m+1} \\ \ddot{x}_{m+2} \\ \vdots \\ \vdots \\ \ddot{x}_{2m} \end{bmatrix} \quad \ddot{e}_3 = \begin{bmatrix} \ddot{x}_{2m+1} \\ \ddot{x}_{2m+2} \\ \vdots \\ \vdots \\ \ddot{x}_{3m} \end{bmatrix} \quad \ddot{e}_{n/2} = \begin{bmatrix} \ddot{x}_{(n/2-1)m+1} \\ \ddot{x}_{(n/2-1)m+2} \\ \vdots \\ \vdots \\ \ddot{x}_{(n/2)m} \end{bmatrix} \quad (26)$$

$$\dot{e}_1 = \begin{bmatrix} \dot{x}_1 \\ \dot{x}_2 \\ \vdots \\ \dot{x}_m \end{bmatrix} \quad \dot{e}_2 = \begin{bmatrix} \dot{x}_{m+1} \\ \dot{x}_{m+2} \\ \vdots \\ \dot{x}_{2m} \end{bmatrix} \quad \dot{e}_3 = \begin{bmatrix} \dot{x}_{2m+1} \\ \dot{x}_{2m+2} \\ \vdots \\ \dot{x}_{3m} \end{bmatrix} \quad \dot{e}_{n/2} = \begin{bmatrix} \dot{x}_{(n/2-1)m+1} \\ \dot{x}_{(n/2-1)m+2} \\ \vdots \\ \dot{x}_{(n/2)m} \end{bmatrix} \quad (27)$$

$$e_1 = \begin{bmatrix} x_1 \\ x_2 \\ \vdots \\ x_m \end{bmatrix} \quad e_2 = \begin{bmatrix} x_{m+1} \\ x_{m+2} \\ \vdots \\ x_{2m} \end{bmatrix} \quad e_3 = \begin{bmatrix} x_{2m+1} \\ x_{2m+2} \\ \vdots \\ x_{3m} \end{bmatrix} \quad e_{n/2} = \begin{bmatrix} x_{(n/2-1)m+1} \\ x_{(n/2-1)m+2} \\ \vdots \\ x_{(n/2)m} \end{bmatrix} \quad (28)$$

where m is the number of inputs and outputs. It is important to emphasize the properties that the Cauer matrix mixed form exhibits. If again the K_i 's go to zero in the state formulation described by equation (15) and (16), they will reduce to:

$$[A_{11}] \ddot{E} = -[A_{21}] \dot{E} + [B]U, \quad (29)$$

and

$$Y = [C_{21}]^T \dot{E}. \quad (30)$$

and letting K 'i's = H 'i's equation (29) and (30) define the state space formulation of the Cauer matrix first form for an n th/2 order system, where n is even, Equations (29) and

(30) are second order differential equations which can be simplified to first order differential equations by assigning a new state variable $[Z] = [\dot{E}]$. Thus equations (29) and (30) can be rewritten as:

$$[A_{11}] \dot{Z} = [A_{21}]Z + [B]U, \quad (31)$$

and

$$Y = [C_{21}]^T Z. \quad (32)$$

where $[A_{11}] = \lim_{K_i \rightarrow 0} [A_1]$ and K_i 's = H_i 's

then:

$$[A_{11}] = \begin{bmatrix} H_1' H_2' & H_1' H_4' & H_1' H_6' & \dots & H_1' H_n' \\ H_1' H_2' & (H_1' + H_3') H_4' & (H_1' + H_3') H_6' & \dots & (H_1' + H_3') H_n' \\ H_1' H_2' & (H_1' + H_3') H_4' & (H_1' + H_3' + H_5') H_6' & \dots & (H_1' + H_3' + H_5') H_n' \\ \vdots & \vdots & \vdots & \ddots & \vdots \\ H_1' H_2' & (H_1' + H_3') H_4' & (H_1' + H_3' + H_5') H_6' & \dots & (H_1' + H_3' + H_5' + \dots + H_{n-1}') H_n' \end{bmatrix} \quad (33)$$

$$\dot{Z} = \begin{bmatrix} \dot{e}_1 \\ \dot{e}_2 \\ \dot{e}_3 \\ \vdots \\ \dot{e}_{n/2} \end{bmatrix}$$

(34)

where $\dot{e}_1, \dot{e}_2, \dot{e}_3 \dots \dot{e}_{n/2}$ are given in equation (27).

$$[A_{21}] = \lim_{K_i's \rightarrow 0} [A_2] = [I], \quad (35)$$

where I is the Identity matrix.

$$Z = \begin{bmatrix} e_1 \\ e_2 \\ e_3 \\ \cdot \\ \cdot \\ \cdot \\ e_{n/2} \end{bmatrix}$$

$$(36)$$

where $e_1, e_2, e_3 \dots e_{n/2}$ are given in equation (28)

$$[C_{21}]^T = \lim_{K_i's \rightarrow 0} [C_2]^T \text{ and } K_i's = H_i's \quad [C_{21}]^T = [H'_2 \ H'_4 \ H'_6 \dots H'_n]. \quad (37)$$

This formulation given by equations (30) through (37) could have been obtained directly by inspection from Figure 3.

Similarly, if all K'i's go to zero in equations (15) and (16) then

$$\dot{E} = -[A_{32}]E + [B]U, \quad (38)$$

and

$$Y = [C_{12}]^T E, \quad (39)$$

where

$$[A_{32}] = \lim_{K'i's \rightarrow 0} [A_3] \text{ and } K'i's = H_i's$$

$$[A_{32}] = \begin{bmatrix} H_1 H_2 & H_1 H_4 & H_1 H_6 & \dots & H_1 H_n \\ H_1 H_2 & (H_1 + H_2) H_4 & (H_1 + H_3) H_6 & \dots & (H_1 + H_3) H_n \\ H_1 H_2 & (H_1 + H_3) H_4 & (H_1 + H_3 + H_5) H_6 & \dots & (H_1 + H_3 + H_5) H_n \\ \vdots & \vdots & \vdots & \vdots & \vdots \\ H_1 H_2 & (H_1 + H_3) H_4 & (H_1 + H_3 + H_5) H_6 & \dots & (H_1 + H_3 + H_5 + \dots + H_{n-1}) H_n \end{bmatrix} \quad (40)$$

and

$$[C_{12}]^T = \lim_{K'i's \rightarrow 0} [C_1]^T \text{ and } K'i's = H_i's$$

$$[C_{12}]^T = [H_2 \ H_4 \ H_6 \ \dots \ H_n]. \quad (41)$$

which define the state space formulation for the Cauer matrix second form. Again, this preceding matrix formulation could have been derived directly by inspection from the block diagram shown in Figure 4. Equations (40) and (41) have the same form of the state space formulation given by Chen [1]. At this point, the following observations may be made regarding the state space formulation just developed:

1. The elements in the state matrix [Ai's] are simple matrix combinations of the matrix quotients

obtained from the continued fraction expansion or Routh's algorithm.

2. The submatrices appearing below the main diagonal have the same value as the submatrices at the diagonal (with exception of $[A_2]$).
3. The submatrices which appear above the main diagonal can be expressed in terms of matrix quotients in a very regular way.
4. State space formulations for the first and second Cauer form can be obtained directly from the Cauer mixed form through direct substitution.

C. APPROXIMATION BY THREE CAUER FORMS

The reduction of the order of a transfer function or decreasing the dimension of a state matrix is highly desirable or sometimes necessary in the analysis and design of control systems.

In terms of continued fractions, the simplification problem is carried out by expanding a given transfer function into one of the Three Matrix Cauer Forms of continued fraction and ignoring some matrix quotients. If the given system is outlined in state variable form, the simplification method is realized by partitioning the matrix and discarding some parts. Several examples are included for demonstrating the power of the method. Also a thorough comparison among the three Cauer forms is presented and their advantages and disadvantages are discussed.

Feedback Gain and Feedforward Gain - Consider the system shown in Figure 5. The closed loop of the overall transfer function is known as follows:

$$T(s) = [H_1 + [F_2 + G]^{-1}]^{-1} \quad (42)$$

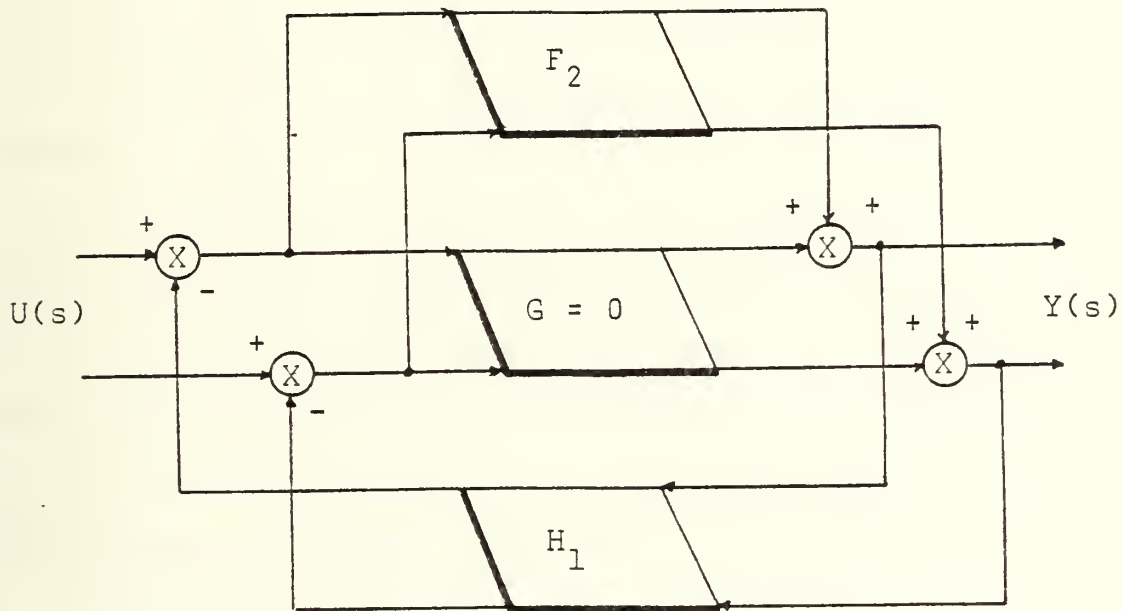

Figure 5. Block diagram for a typical feedback system with a minor feedforward loop with two inputs and two outputs.

where $G = 0$. Equation (42) can be considered as the simplest continued matrix fraction expansion. The physical meaning implied in the formula is significant. It is easily seen that when F_2 is high the overall gain can be approximated by H_1^{-1} , in other words, H_1 dominates the behavior of the system.

This fact establishes the feedback loop as the most important link for influencing the behavior of the system, leaving the feedforward loop as the second most important link. Furthermore if the subsystem G, instead of being zero is still a high order transfer function, it is possible to continue the expansion one after another. This corresponds to a combination of many feedback and feedforward blocks as shown in Figure 6. It should be noted that the most dominant term is H_1 and the second influence term is F_2 . When the matrix quotients in the continued fraction are lower and lower in positions, they are less and less important as far as the influence to the performance of the system is concerned. This observation is the general basis for the simplification technique developed for multivariable systems.

Considering a simple case, a second order transfer function such as:

$$T(s) = [A_{22}s + A_{21}][A_{13}s^2 + A_{12}s + A_{11}]^{-1} \quad (43)$$

can be expanded into three different matrix Cauer forms of continued fraction as follows:

$$F_{c1}(s) = [H'_1s + [H'_2 + [H'_3s + [H'_4]^{-1}]^{-1}]^{-1} \quad (44)$$

$$F_{c2}(s) = [H_1 + [H_2 \frac{1}{s} + [H_3 + [H_4 \frac{1}{s}]^{-1}]^{-1}]^{-1} \quad (45)$$

$$F_{c3}(s) = [K_1 + K'_1s + [K_2 \frac{1}{s} + K'_2]^{-1}]^{-1} \quad (46)$$

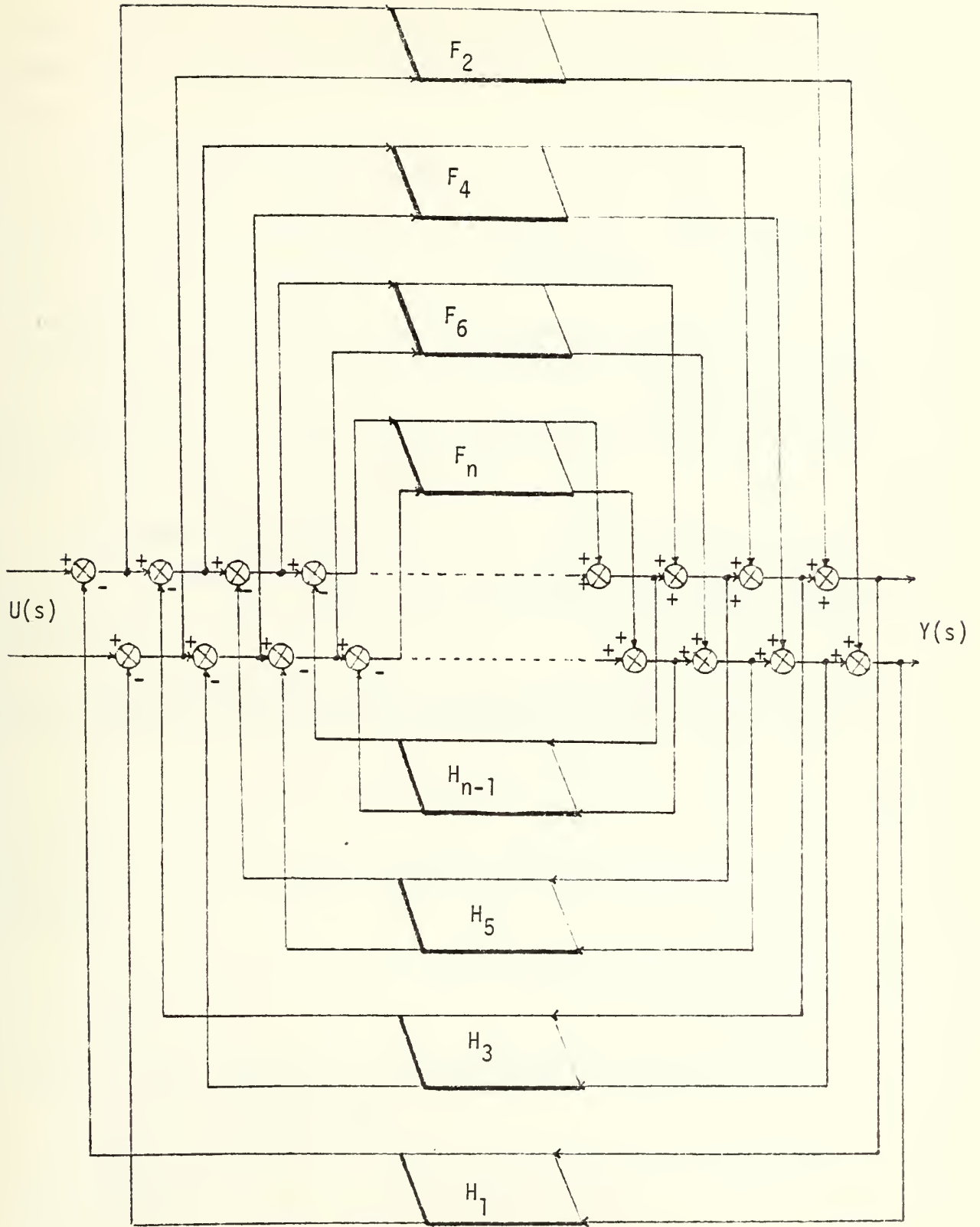

Figure 6. Block diagram representation of a continued fraction expansion.

where $F_{c1}(s)$, $F_{c2}(s)$, and $F_{c3}(s)$ are the first, second and mixed Cauer continued matrix fraction expansions of equation (43).

From previous observation, it is known that the most dominant term in equations (44), (45), and (46) is $H_1's$, H_1 and $K_1 + K_1's$ respectively. It is desirable to find a meaningful interpretation for the dominant term of each one of the expansions just performed. This task is accomplished by applying the initial and final value theorems to equations (44), (45), and (46) as follows.

1. Cauer First Form

Performing the inverse procedure on $F_{c1}(s)$ it can be written as

$$F_{c1}(s) = \frac{Y(s)}{U(s)} = [H_2'H_3'H_4'S + H_2' + H_4'] [H_1'H_2'H_3'H_4'S^2 + (H_1'H_2' + H_1'H_4' + H_3'H_4')S + I]^{-1} \quad (47)$$

Applying the final value theorem to equation (47) and allowing

$$U(s) = \begin{bmatrix} 1_1 \\ 1_2 \\ \vdots \\ 1_m \end{bmatrix} \frac{1}{s} \quad \text{where } m \text{ is the number of inputs is found that}$$

$$y(t \rightarrow \infty) = [H_2 + H_4] \begin{bmatrix} 1_1 \\ 1_2 \\ \vdots \\ 1_m \end{bmatrix} \quad (48)$$

similarly, applying the initial value theorem and allowing

$$U(s) = \begin{bmatrix} 1_1 \\ 1_2 \\ \vdots \\ 1_m \end{bmatrix}$$

$$y(t \rightarrow 0) = [H'_1]^{-1} \begin{bmatrix} 1_1 \\ 1_2 \\ \vdots \\ 1_m \end{bmatrix} \quad (49)$$

The meaning implied in equations (48) and (49) is very significant. The initial conditions dominate the behavior of the system. In other words, the Cauer first form influences very heavily the transient part of the response.

2. Cauer Second Form

Performing the inverse procedure of $F_{c2}(s)$, this can be written as:

$$F_{c2}(s) = \frac{Y(s)}{U(s)} = [H_2 + H_4 s + H_2 H_3 H_4] [I s^2 + (H_1 H_2 + H_1 H_4 + H_3 H_4) s + H_1 H_2 H_3 H_4]^{-1} \quad (50)$$

Applying the final value theorem to equation (50) and allowing

$$U(s) = \begin{bmatrix} 1_1 \\ 1_2 \\ \cdot \\ \cdot \\ 1_m \end{bmatrix} \frac{1}{s} \text{ it is found that } y(t \rightarrow \infty) = [H_1]^{-1} \begin{bmatrix} 1_1 \\ 1_2 \\ \cdot \\ \cdot \\ 1_m \end{bmatrix} \quad s \rightarrow 0 \quad (51)$$

Similarly, applying the initial value theorem and allowing

$$U(s) = \begin{bmatrix} 1_1 \\ 1_2 \\ \cdot \\ \cdot \\ 1_m \end{bmatrix} y(t \rightarrow 0) = [H_2 + H_4] \begin{bmatrix} 1_1 \\ 1_2 \\ \cdot \\ \cdot \\ 1_m \end{bmatrix} \quad s \rightarrow \infty \quad (52)$$

The results obtained in equations (51) and (52) imply that the final or steady state value dominates the behavior of the system. In other words, the Causer second form influences very heavily the steady state part of the system response.

3. Causer Mixed Form

Performing the inverse procedure on $F_{c3}(s)$ this can be written as:

$$F_{c3}(s) = \frac{Y(s)}{U(s)} = [K'_2 s + K_2] [K'_1 K'_2 s^2 + (I + K_1 K'_2 + K'_1 K_2) s + K_1 K_2]^{-1} \quad (53)$$

Applying the final and initial value theorems to equation (53) in the same fashion as for the previous forms, the following results are obtained:

$$y(t \rightarrow \infty) = [K_1]^{-1} \begin{bmatrix} 1_1 \\ 1_2 \\ \vdots \\ 1_m \end{bmatrix} \quad (54)$$

and

$$y(t \rightarrow 0) = [K_1']^{-1} \begin{bmatrix} 1_1 \\ 1_2 \\ \vdots \\ 1_m \end{bmatrix} \quad (55)$$

These results show the steady state value and the initial conditions to dominate on equal levels of significance the behavior of the system. Thus the Cauer mixed form influences the system response in the transient part as well as in the steady state part. This fact makes the Cauer mixed form a better and more accurate device to be used in the simplification and reduction techniques of transfer functions of multivariable systems.

D. TRUNCATION OF THE CAUER MIXED FORM THE BEST APPROXIMATION IN A DEFINITE MATHEMATICAL SENSE FOR MULTIVARIABLE SYSTEM REDUCTION

In a recent paper, M.J. Goldman and C.T. Leondes [8] developed the mathematical basis for the simplification technique involving the truncation of the mixed Cauer form for the single input single output case. In this section, an extension of their work to the multivariable case is presented and its superiority over any other form of continued fractions is established.

The transfer function matrix $T(s)$ for multivariable system can be expressed as follows:

$$T(s) = [A_{2,n}S^{n-1} + A_{2,n-1}S^{n-2} + \dots + A_{23}S^2 + A_{22}S + A_{21}] \times [A_{1,n+1}S^n + A_{1,n}S^{n-1} + \dots + A_{13}S^2 + A_{12}S + A_{11}]^{-1} \quad (56)$$

where $A_{i,j}$ are constant, m by m matrices and $A_{ij} = a_j[I]$, $j = 1, 2, \dots, n+1$, where each a_j is a coefficient of the common-denominator polynomial or

$$\Delta(s) = \sum_{j=1}^{n+1} a_j S^{j-1} \text{ and } [I] \text{ is the identity matrix.}$$

The n th convergent of a mixed matrix Cauer form can be represented by the following two configurations:

$$A_n B_n^{-1} = [K_1 + K'_1 S + S[K_2 + K'_2 S + S[\dots S[K_n + K'_n S]^{-1}]^{-1}]^{-1} \quad (57)$$

$$A'_n B_n^{-1} = \frac{1}{S} [K_1 \frac{1}{S} + K'_1 + \frac{1}{S} [K_2 \frac{1}{S} + K'_2 + \frac{1}{S} [\dots \frac{1}{S} [K_n \frac{1}{S} + K'_n]^{-1}]^{-1}]^{-1} \quad (58)$$

where

$$\left. \begin{aligned} A_n &= K_n A_{n-1} + SK'_n A_{n-1} + SA_{n-2}, \quad A_0 = 0 \quad A_1 = I \\ B_n &= K_n B_{n-1} + SK'_n B_{n-1} + SB_{n-2}, \quad B_0 = 0 \quad B_1 = K_1 + K'_1 S \end{aligned} \right\} \quad (59)$$

$$\left. \begin{aligned} A'_n &= \frac{1}{S} K_n A'_{n-1} + K'_n A'_{n-1} + \frac{1}{S} A'_{n-2}, \quad A'_0 = 0 \quad A'_1 = \frac{1}{S} I \\ B'_n &= \frac{1}{S} K_n B'_{n-1} + K'_n B'_{n-1} + \frac{1}{S} B'_{n-2}, \quad B'_0 = I \quad B'_1 = \frac{1}{S} K_1 + K'_1 \end{aligned} \right\} \quad (60)$$

Recurrence relations (59) and (60) have been derived from standard results in the theory of continued fractions (Rice 1964) and K_n 's and K'_n 's from the generalized matrix Routh Algorithm (Shieh and Gaudiano 1974).

Since

$$A_n B_n^{-1} = A'_n B_n^{-1} \quad (61)$$

then

$$\begin{aligned} A_n &= S^n A'_n \\ B_n &= S^n B'_n \quad n = 0, 1, 2, \dots \end{aligned} \quad (62)$$

Proof:

Substituting equation (62) into (59)

$$\left. \begin{aligned}
 S^n A'_n &= S^{n-1} K'_n A'_{n-1} + S K'_n S^{n-1} A'_{n-1} + S S^{n-2} A'_{n-2} \\
 \text{and} \\
 S^n B'_n &= S^{n-1} K'_n B'_{n-1} + S K'_n S^{n-1} B'_{n-2}
 \end{aligned} \right\} \quad (63)$$

Dividing equation (63) by S^n , recurrence relation (60) is obtained. (It is important to notice the generality of equations (59) and (60). By making all the K 's = 0, the recurrence relationships for the n th convergents for the Caer first form is obtained, similarly by making all the K 'is = 0, the recurrence relationships for the n th covergents for the Caer second form are obtained.)

From (59)

$$\left. \begin{aligned}
 K_n &= [A_n - S K'_n A_{n-1} - S A_{n-2}] A_{n-1}^{-1} \\
 \text{and} \\
 K_n &= [B_n - S K'_n B_{n-1} - S B_{n-2}] B_{n-1}^{-1}
 \end{aligned} \right\} \quad (64)$$

Solving and simplifying terms

$$A_n B_{n-1} - B_n A_{n-1} = -S(A_{n-1} B_{n-2} - B_{n-1} A_{n-2}) \quad (65)$$

so by induction

$$A_n B_{n-1} - B_n A_{n-1} = (-S)^{n-1} * I. \quad (66)$$

where I is the Identity Matrix.

Hence, the difference between two consecutive convergents is given by

$$A_n B_n^{-1} - A_{n-1} B_{n-1}^{-1} = (-S)^{n-1} [B_n B_{n-1}]^{-1}. \quad (67)$$

Similarly, from (60), and following the same procedure

$$A'_n B'_{n-1} - B'_n A'_{n-1} = \frac{1}{S} (A'_{n-1} B'_{n-2} - B'_{n-1} A'_{n-2}). \quad (68)$$

So by induction

$$A'_n B'_{n-1} - B'_n A'_{n-1} = \frac{1}{S} \left(-\frac{1}{S}\right)^{n-1} * I. \quad (69)$$

and the difference between two consecutive convergents is given by

$$A'_n B_n^{-1} - A'_{n-1} B_{n-1}^{-1} = \frac{1}{S} * \left(-\frac{1}{S}\right)^{n-1} [B'_n B'_{n-1}]^{-1} \quad (70)$$

By looking at the recurrence relations (59) and (60), is observed that when $S=0$ or $S=\infty$, respectively, all B_n and all B'_n are non-zero provided that all K_n and K'_n are non-zero. This is equivalent to apply the final value theorem to equation (67) for a unit step inputs; and applying the initial value theorem to equation (70) for an impulse response.

Hence,

$$\left. \begin{aligned} \frac{d^j}{ds^j} [A_n B_n^{-1} - A_{n-1} B_{n-1}^{-1}]_{S=0} &= \lim_{s \rightarrow 0} \frac{1}{s} I * S(-S)^{n-1} [B_n B_{n-1}]^{-1} \\ &= 0 \quad j = 0, 1, \dots, n-2 \end{aligned} \right\} \quad (71)$$

Similarly,

$$\left. \begin{aligned} \frac{d^j}{ds^j} [A'_n B_n^{-1} - A'_{n-1} B_{n-1}^{-1}]_{S=\infty} &= \lim_{s \rightarrow \infty} s * \frac{1}{s} I \left(-\frac{1}{s} \right) [B'_n B'_{n-1}]^{-1} \\ &= 0 \quad j = 0, 1, \dots, n-2 \end{aligned} \right\} \quad (72)$$

Equations (71) and (72) show the results that were expected, namely: The (n-1)th approximant and the nth approximant goes to zero in the sense of minimizing the follows semi-norms of the difference

$$\left. \begin{aligned} ||F_{n-1}(s)||_{n-1} &= \sum_{j=0}^{n-2} \left| \frac{d^j}{ds^j} F_{n-1}(s) \right|_{s=0} = 0 \\ ||F'_{n-1}(s)||_{n-1} &= \sum_{j=0}^{n-2} \left| \frac{d^j}{ds^j} F'_{n-1}(s) \right|_{s=\infty} = 0 \end{aligned} \right\} \quad (73)$$

where

$$\left. \begin{aligned} F_{n-1}(s) &= A_n B_n^{-1} - A_{n-1} B_{n-1}^{-1} \\ \text{and} \\ F'_{n-1}(s) &= A'_n B_n^{-1} - A'_{n-1} B_{n-1}^{-1} \end{aligned} \right\} \quad (74)$$

Note: A semi-norm is a norm which does not satisfy the norm axiom " $||F(s)|| = 0$ implies $F(s) = 0$ ".

Since the derivatives in (73) correspond to the coefficients in the Taylor series expansion of the functions $F_{n-1}(s)$ and $F'_{n-1}(s)$ about the points $S=0$ and $S=\infty$. Then, it can be deduced that the output difference to a nth approximant

has the same Taylor series as the original function for terms up to S^{n-1} and $(\frac{1}{S})^{n-1}$, effectively neglecting the part of the transfer function which differentiates the input $\geq n$ times in the steady state as well as in the transient. This gives the sense in which the approximation by the Caueer mixed form works.

E. SIMPLIFYING A MATRIX TRANSFER FUNCTION

If the following nth order system is given,

$$T(s) = [A_{2,n}S^{n-1} + \dots A_{24}S^3 + A_{23}S^2 + A_{22}S + A_{21}] \times [A_{1,n+1}S^n + \dots A_{14}S^3 + A_{13}S^2 + A_{12}S + A_{11}]^{-1}. \quad (75)$$

a simplified model of the system is desired. By performing the Generalized Routh's Matrix Array, the matrix quotients of the Caueer mixed form in equation (3) can be obtained.

If an m order is desired only the first m pairs of K's and K'is should be kept in equation (3) and the remaining should be omitted. After the inverse procedure has been performed on the truncated continued fraction, the simplified model is obtained.

For example the general transfer function obtained by the matrix continued fraction expansion for the Caueer mixed form is given in equation (76).

$$T(s) = [K_1 + K'_1 S + [K_2 \frac{1}{S} + K'_2 + [K_3 + K'_3 S + [K_4 \frac{1}{S} + K'_4 + [\dots]^{-1}]^{-1}]^{-1}]^{-1}]^{-1} \quad (76)$$

If a second order simplified model is required, only the first two pairs of matrix quotients will be kept, that is K_1 , K'_1 , K_2 , and K'_2 , and the rest should be discarded.

After the inverse procedure has been performed on the truncated matrix continued fraction expansion, the transfer function given in equation (77) is obtained. Equation (77) is the simplified model in Mixed Matrix Cauer Form.

$$T(s) = [K'_2 S + K_2] \times [K'_1 K'_2 S^2 + (I + K_1 K'_2 + K'_1 K_2) S + K_1 K_2]^{-1} \quad (77)$$

The truncation procedure outlined above, applies in similar manner for the Cauer's first and Cauer's second forms.

This methodology is particularly advantageous when state space terminology is used. For the Cauer mixed form, the state space formulation is written as follows:

$$\begin{bmatrix}
 K'_1 K'_2 & K'_1 K'_4 & K'_1 K'_6 & \dots & K'_1 K'_n \\
 K'_1 K'_2 & (K'_1 + K'_3) K'_4 & (K'_1 + K'_3) K'_6 & \dots & (K'_1 + K'_3) K'_n \\
 K'_1 K'_2 & (K'_1 + K'_3) K'_4 & (K'_1 + K'_3 + K'_5) K'_6 & \dots & (K'_1 + K'_3 + K'_5) K'_n \\
 \vdots & \vdots & \vdots & \vdots & \vdots \\
 K'_1 K'_2 & (K'_1 + K'_3) K'_4 & (K'_1 + K'_3 + K'_5 + \dots + K'_{n-1}) K'_6 & \dots & (K'_1 + K'_3 + K'_5 + \dots + K'_{n-1}) K'_n
 \end{bmatrix}
 \begin{bmatrix}
 \ddot{E}_1 \\
 \ddot{E}_2 \\
 \ddot{E}_3 \\
 \vdots \\
 \ddot{E}_{n/2}
 \end{bmatrix}
 =
 \begin{bmatrix}
 I + K'_1 K_2 + K_1 K'_2 & K'_1 K_4 + K_1 K'_4 & \dots & K'_1 K_n + K_1 K'_n \\
 K'_1 K_2 + K_1 K'_2 & I + (K'_1 + K'_3) K_4 + (K_1 + K_3) K'_4 & \dots & (K'_1 + K'_3) K_n + (K_1 + K_3) K'_n \\
 K'_1 K_2 + K_1 K'_2 & (K'_1 + K'_3) K_4 + (K_1 + K_3) K'_4 & \dots & (K'_1 + K'_3 + K'_5) K_n + (K_1 + K_3 + K_5) K'_n \\
 \vdots & \vdots & \vdots & \vdots \\
 K'_1 K_2 + K_1 K'_2 & (K'_1 + K'_3) K_4 + (K_1 + K_3) K'_4 & \dots & (K'_1 + K'_3 + \dots + K'_{n-1}) K_n + (K_1 + K_3 + \dots + K_{n-1}) K'_n
 \end{bmatrix}
 \begin{bmatrix}
 \dot{E}_1 \\
 \dot{E}_2 \\
 \dot{E}_3 \\
 \vdots \\
 \dot{E}_{n/2}
 \end{bmatrix}$$

$$\begin{bmatrix}
K_1 K_2 & K_1 K_4 & & \dots & K_1 K_n \\
K_1 K_2 & (K_1 + K_3) K_6 & & \dots & (K_1 + K_3) K_n \\
K_1 K_2 & (K_1 + K_3) K_4 & (K_1 + K_3 + K_5) K_6 & \dots & (K_1 + K_3 + K_5) K_n \\
\vdots & \vdots & \vdots & \vdots & \vdots \\
K_1 K_2 & (K_1 + K_3) K_4 & (K_1 + K_3 + K_5) K_6 & \dots & (K_1 + K_3 + \dots + K_{n-1}) K_n
\end{bmatrix}
\begin{bmatrix}
E_1 \\
E_2 \\
E_3 \\
\vdots \\
E_{n/2}
\end{bmatrix}
+
\begin{bmatrix}
I \\
I \\
I \\
\vdots \\
I
\end{bmatrix}
U
\tag{78}$$

and

$$Y = [K_2, K_4, K_6, \dots, K_n]
\begin{bmatrix}
E_1 \\
E_2 \\
E_3 \\
\vdots \\
E_{n/2}
\end{bmatrix}
+ [K'_2, K'_4, K'_6, \dots, K'_n]
\begin{bmatrix}
\dot{E}_1 \\
\dot{E}_2 \\
\dot{E}_3 \\
\vdots \\
\dot{E}_{n/2}
\end{bmatrix}
\tag{79}$$

where

$$\ddot{E}_1 = \begin{bmatrix} \ddot{e}_1 \\ \ddot{e}_2 \\ \vdots \\ \ddot{e}_m \end{bmatrix} \quad
\ddot{E}_2 = \begin{bmatrix} \ddot{e}_{m+1} \\ \ddot{e}_{m+2} \\ \vdots \\ \ddot{e}_{2m} \end{bmatrix} \quad
\ddot{E}_{n/2} = \begin{bmatrix} \ddot{e}_{(n/2-1)m+1} \\ \ddot{e}_{(n/2-1)m+2} \\ \vdots \\ \ddot{e}_{(n/2)m} \end{bmatrix}$$

I = identity matrix, and $\dot{E}_1, \dot{E}_2, \dots, \dot{E}_{n/2}, E_1, E_2, \dots, E_{n/2}$ have the same dimensions as $\ddot{E}_1, \ddot{E}_2, \dots, \ddot{E}_{n/2}$ respectively and m corresponds to number of inputs or outputs.

It is interesting to note that the simplification of the state equations can be carried out by partitioning the matrix, or by only keeping a part of the original matrix as a simplified model. In other words, if a simplified model of a two dimensional matrix is required which is equivalent to a 2 x (2m) order transfer function, the upper left hand corner of the original matrix is taken as the simplified model.

Therefore:

$$\begin{bmatrix} K'_1 K'_2 & K'_1 K'_4 \\ K'_1 K'_2 & (K'_1 + K'_3) K'_4 \end{bmatrix} \begin{bmatrix} \ddot{E}_1 \\ \ddot{E}_2 \end{bmatrix} = - \begin{bmatrix} I + K'_1 K_2 + K_1 K'_2 & K'_1 K_4 + K_1 K'_4 \\ K'_1 K_2 + K_1 K'_2 & I + (K'_1 + K'_3) K_4 + (K_1 + K_3) K'_4 \end{bmatrix} \begin{bmatrix} \dot{E}_1 \\ \dot{E}_2 \end{bmatrix} \\ + \begin{bmatrix} K_1 K_2 & K_1 K_4 \\ K_1 K_2 & (K_1 + K_3) K_4 \end{bmatrix} \begin{bmatrix} E_1 \\ E_2 \end{bmatrix} + \begin{bmatrix} I \\ I \end{bmatrix} U \quad (80)$$

$$Y = [K_2, K_4] \begin{bmatrix} E_1 \\ E_2 \end{bmatrix} + [K'_2, K'_4] \begin{bmatrix} \dot{E}_1 \\ \dot{E}_2 \end{bmatrix} \quad (81)$$

where the vector \ddot{E}_1 , \ddot{E}_2 , \dot{E}_1 , \dot{E}_2 , E_1 , E_2 , keeping the same dimensions as were given for the equations (78) and (79).

The method used for the simplifications of a transfer function and state space formulation based on the Cauer mixed form holds in the same fashion for the Cauer first and second forms.

For effects of simulation Figure 7 shows a diagram for two inputs two outputs fourth order system for the Cauer Matrix mixed form, in similar form for the Cauer first and

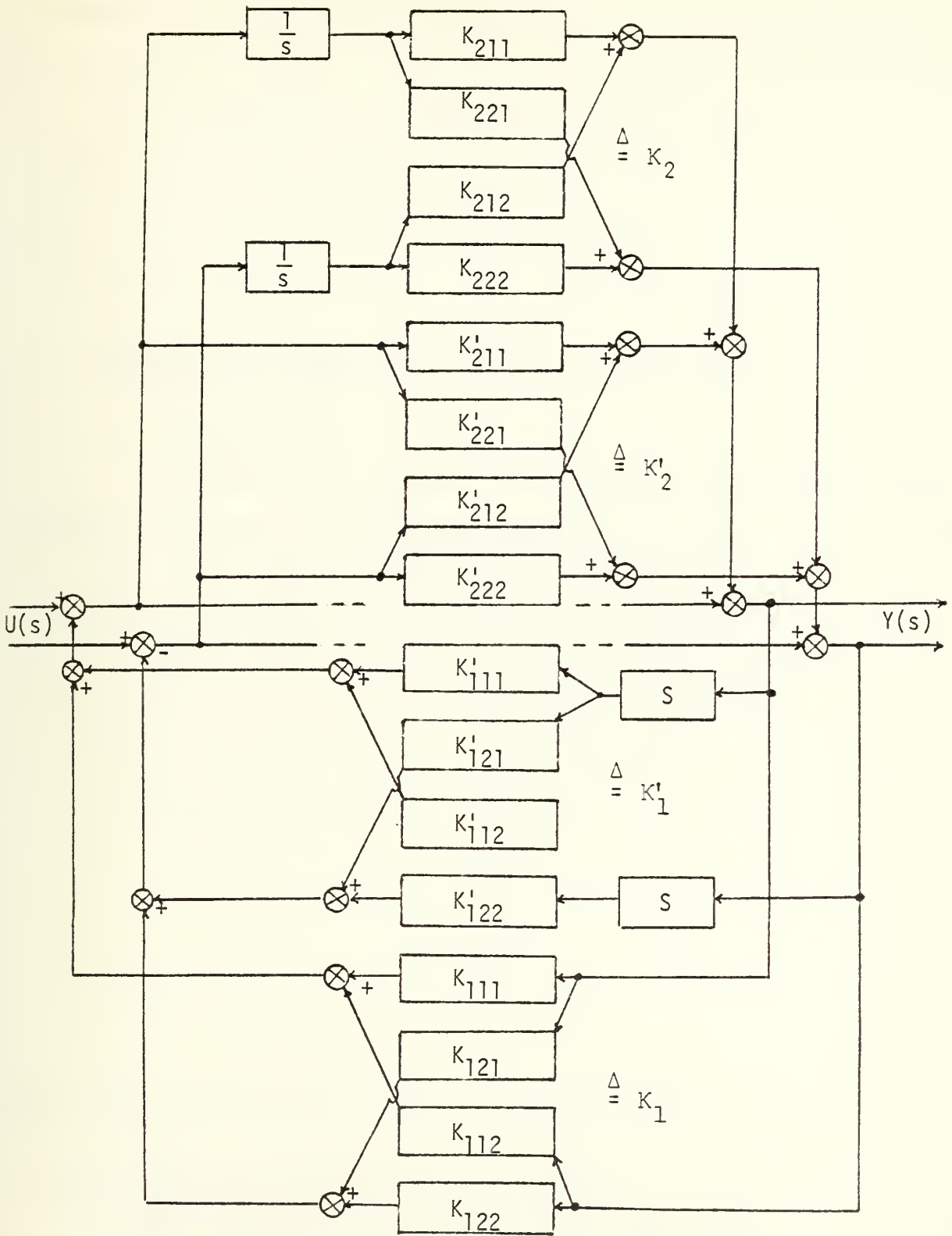

Figure 7. Simulation diagram for fourth order system with $m = 2$ for Caer matrix mixed form.

second form a simulation diagram can be obtained as given in Figures 8 and 9.

It is important to notice the number of reductions, q , which one can realize are constrained by the number of inputs, m , and the order of the system, n , where $q = n - km$ for $k = 1, 2, \dots$ and $q > 0$.

E. NUMERICAL EXAMPLES AND GRAPHICAL COMPARISON OF THE THREE CAUER FORMS

1. Example 2.1

Consider two inputs, two outputs fourth order system where a reduced second order system is required.

The state space equations for the system are:

$$\dot{x} = \begin{bmatrix} 0 & 0 & 3.25 & -1.125 \\ 0 & 0 & 2.25 & -0.125 \\ -1 & 0.5 & -1.5 & -0.5 \\ -1.5 & -0.5 & -1.0 & -4.0 \end{bmatrix} x + \begin{bmatrix} 0 & 0 \\ 0 & 0 \\ 0.5 & 0 \\ 1 & 0.5 \end{bmatrix} u \quad (82)$$

$$Y = \begin{bmatrix} 1 & -1 & 1 & 1 \\ 0 & 1 & -1 & 1 \end{bmatrix} x \quad (83)$$

The transfer function for this system is given by equation (84).

$$T(s) = \begin{bmatrix} s+1 & s-1 \\ -2 & s+1 \end{bmatrix} \begin{bmatrix} 2s^2 + 3s + 2 & s-1 \\ -4s^2 - 4s - 1 & 2s^2 + 6s + 3 \end{bmatrix}^{-1} \quad (84)$$

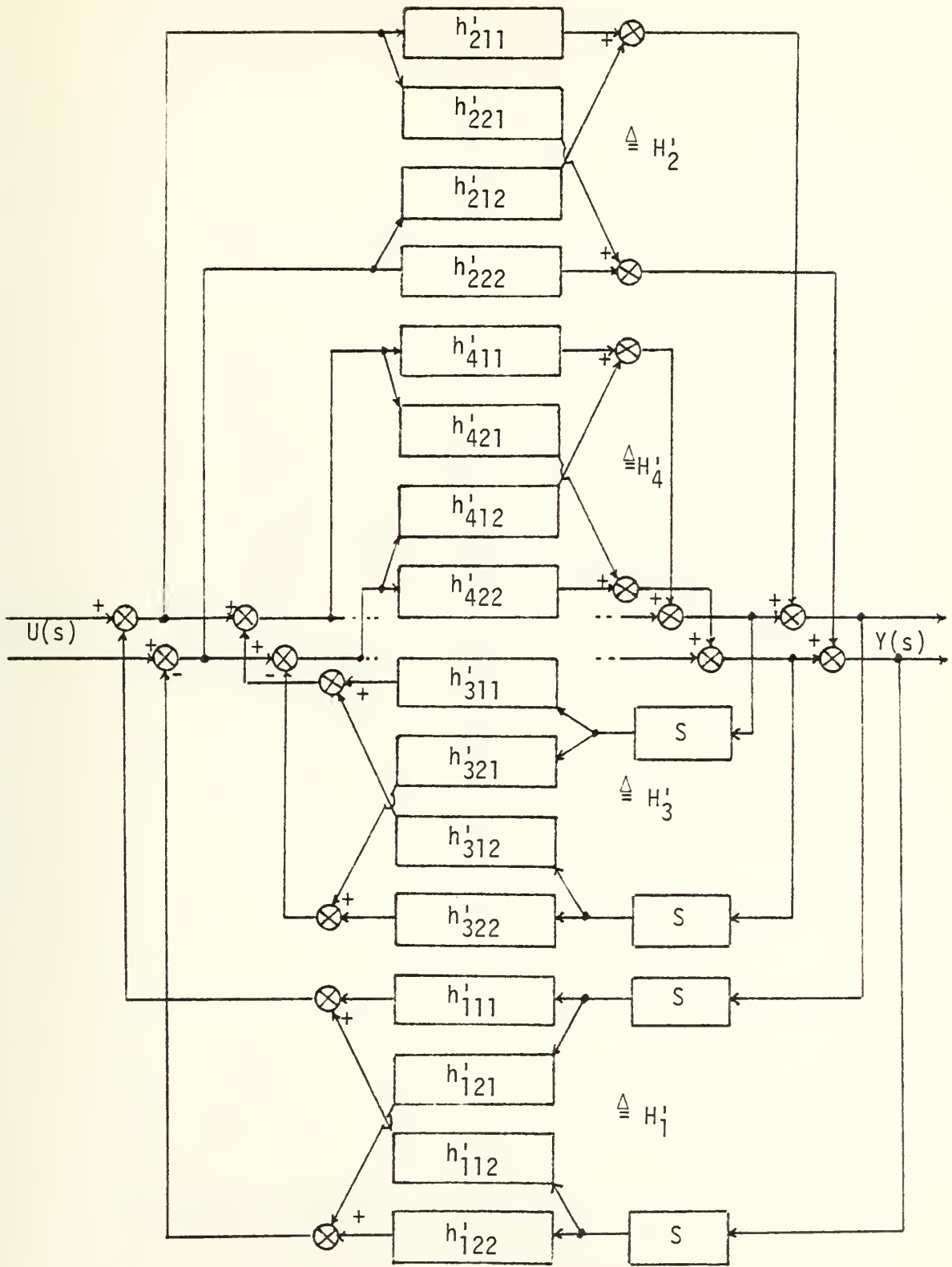

Figure 8. Simulation diagram for fourth order system with $m = 2$ for Cauchy matrix first form.

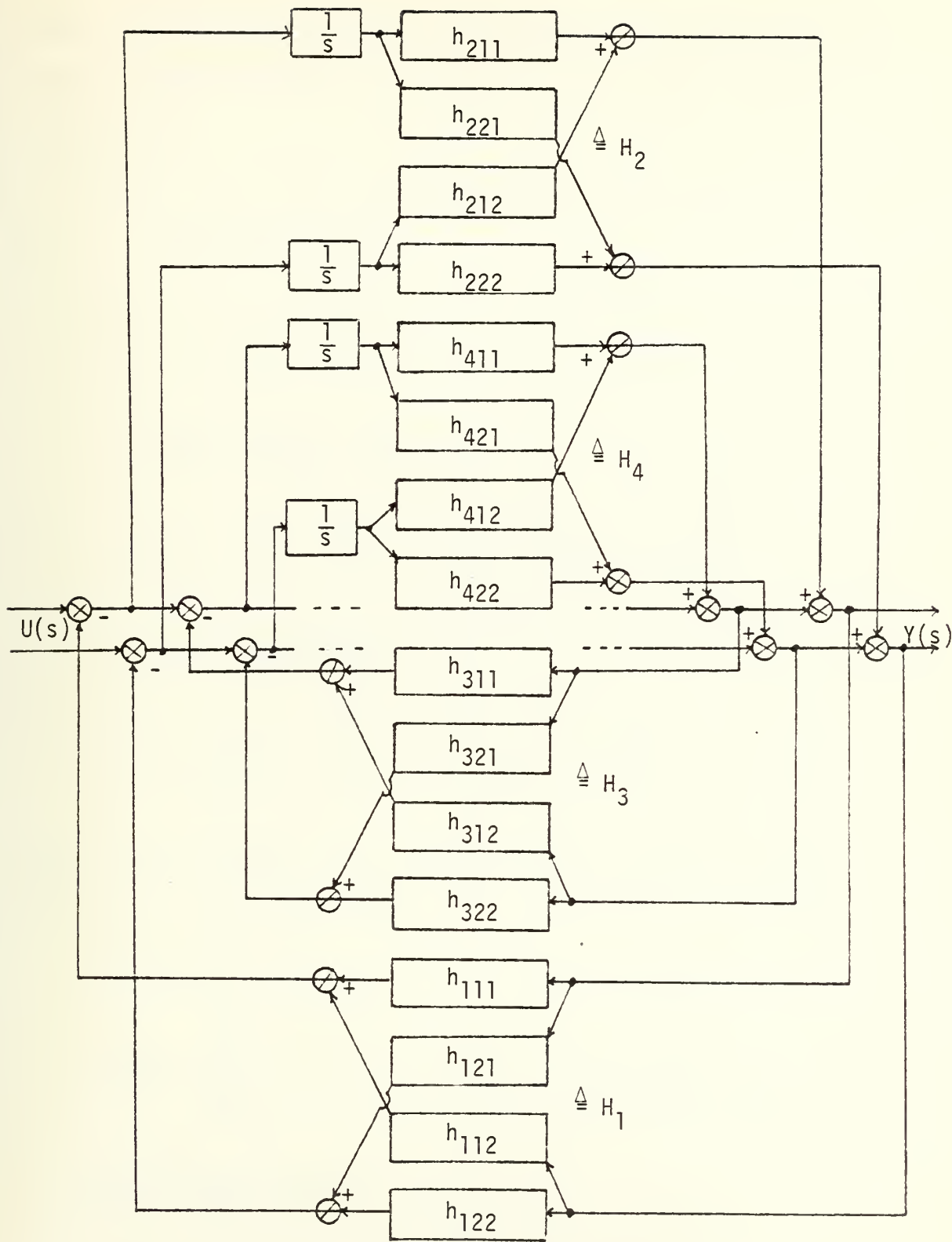

Figure 9. Simulation diagram for fourth order system with $m = 2$ for Cauer matrix second form.

From the transfer function, the matrix Routh's Array and the following matrix quotients for the three Cauer forms are obtained.

Therefore, reduced second order models are:

Cauer first form

$$H'_1 = \begin{bmatrix} 1 & -1 \\ -1 & 3 \end{bmatrix} \quad H'_2 = \begin{bmatrix} 5 & -1 \\ 1 & 5 \end{bmatrix} \frac{1}{13}$$

Cauer second form

$$H_1 = \begin{bmatrix} 2 & 1 \\ 1 & 4 \end{bmatrix} \quad H_2 = \begin{bmatrix} 0.5 & 0 \\ 0.125 & 0.25 \end{bmatrix}$$

Cauer mixed form

$$K_1 = \begin{bmatrix} 2 & 1 \\ -1 & 2 \end{bmatrix} \quad K'_1 = \begin{bmatrix} 1 & -1 \\ -1 & 3 \end{bmatrix}$$

where their respective transfer functions are given in equations (84), (85), and (86).

Cauer first form:

$$F_{c1}(s) = \begin{bmatrix} 3c + 2.5 & s - 0.5 \\ s + 0.5 & s + 2.5 \end{bmatrix} \frac{1}{2s^2 + 10s + 6.5} \quad (84)$$

Cauer second form:

$$F_{c2}(s) = \begin{bmatrix} 4s + 2 & -1 \\ s + 1 & 2s + 2 \end{bmatrix} \frac{1}{9s^2 + 13s + 5} \quad (85)$$

Cauer mixed form

$$F_{c3}(s) = \begin{bmatrix} 3s + 2 & s - 1 \\ s + 1 & s + 2 \end{bmatrix} \frac{1}{2s^2 + 8s + 5} \quad (86)$$

Figure 10 presents the step responses of reduced models just developed, where (10a) corresponds to the output (1) and (10b) corresponds to the output (2).

2. Example 2.2

The following example shows the reduced systems in Cauer first and second forms are only stable for a second order approximation, their fourth order approximation provides an unstable response. Whereas, the fourth order approximation for the Cauer mixed form is completely stable. Furthermore, the Cauer first form gives a poor approximation in the steady state portion as is expected. Consider the following sixth order system with two inputs two outputs as given in equations (87) and (88).

$$\dot{x} = \begin{bmatrix} 0 & 0 & 1.0 & 0 & 0 & 0 \\ 0 & 0 & 0 & 1.0 & 0 & 0 \\ 0 & 0 & 0 & 0 & 1.0 & 0 \\ 0 & 0 & 0 & 0 & 0 & 1.0 \\ -50 & 9.96 & -108.5 & 19.6 & -16.5 & 4 \\ 49 & -19.96 & 107 & -39.6 & 13 & -10 \end{bmatrix} x + \begin{bmatrix} 0 & 0 \\ 0 & 0 \\ 0 & 0 \\ 0 & 0 \\ 2 & -1 \\ -2 & 2 \end{bmatrix} U, \quad (87)$$

$$Y = \begin{bmatrix} 10 & 0.4 & 1 & 0.2 & 0 & 0.2 \\ 1.0 & 4 & 2 & 1 & 1 & 0 \end{bmatrix} x. \quad (88)$$

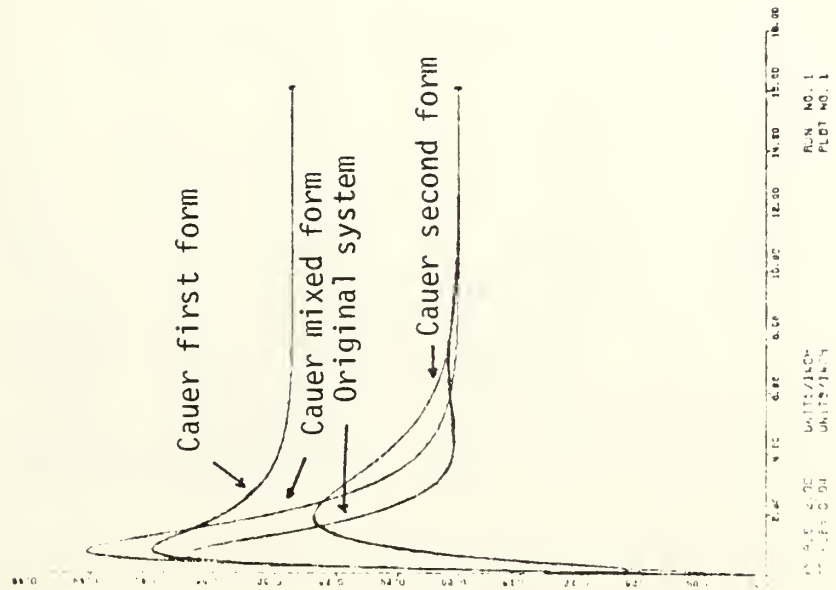

(a)

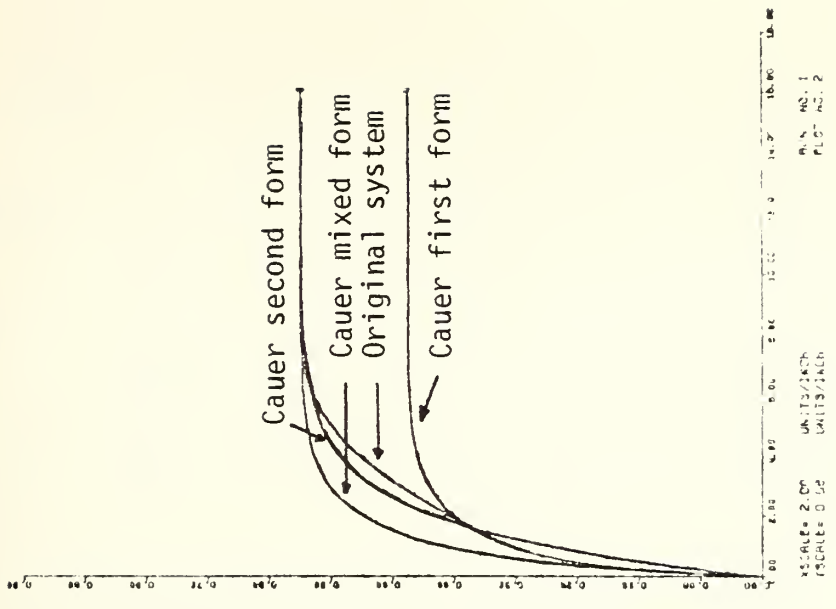

(b)

Figure 10. Outputs for the original fourth order system and reduced second order system in the three Cauer forms.

The transfer function of this system is given by equation (89).

$$T(s) = \begin{bmatrix} s + 10 & 0.2s^2 + 0.2s + 0.1 \\ s^2 + 2s + 1 & s + 4 \end{bmatrix}^*$$

$$\begin{bmatrix} s^3 + 10s^2 + 55s + 25 & 0.5s^2 + s^2 + 0.2s + 0.2 \\ s^3 + 3.5s^2 + 1.5s + 0.5 & s^3 + 6s^2 + 20s + 10 \end{bmatrix}^{-1}$$

(89)

or if the inverse is to performed

$$T(s) = \begin{bmatrix} -0.25s^5 + 0.1s^4 + 14.9s^3 + 79.25s^2 + 209.75s + 99.95 \\ s^5 + 7s^4 + 25.5s^3 + 40.5s^2 + 33.5s + 8 \\ 0.2s^5 + 1.7s^4 + 7.1s^3 + 6.8s^2 + 8.48s + 2.3 \\ -0.5s^5 - s^4 + 11.3s^3 + 93.58s^2 + 244.76s + 99.98 \end{bmatrix}^*$$

$$\frac{1}{0.5s^6 + 13.25s^5 + 130.55s^4 + 562.53s^3 + 1349.13s^2 + 1049.87s + 249.99}$$

(90)

a. Cauer Matrix First Form

Performing the respective Routh's Array:

$$\begin{bmatrix} 1 & 0.5 \\ 1 & 1 \end{bmatrix} \begin{bmatrix} 10 & 1 \\ 3.5 & 6 \end{bmatrix} \begin{bmatrix} 55 & 0.2 \\ 1.5 & 20 \end{bmatrix}$$

$$\begin{bmatrix} 0 & 0.2 \\ 1 & 0 \end{bmatrix} \begin{bmatrix} 1 & 0.2 \\ 2 & 1 \end{bmatrix} \begin{bmatrix} 10 & 0.1 \\ 1 & 4 \end{bmatrix}$$

$$\begin{bmatrix} 5.5 & -0.5 \\ -3.5 & 4 \end{bmatrix} \begin{bmatrix} 29 & -4.05 \\ -49.5 & 15.5 \end{bmatrix} \begin{bmatrix} 25 & 0.02 \\ 0.5 & 10 \end{bmatrix}$$

$$\begin{bmatrix} 2.686 & -0.5 \\ -2.5 & 1.417 \end{bmatrix} \begin{bmatrix} 9.1 & -0.444 \\ -3.95 & 3.75 \end{bmatrix}$$

$$\begin{bmatrix} 7.823 & -4.996 \\ -53.664 & 3.163 \end{bmatrix} \begin{bmatrix} 25 & 0.02 \\ 0.5 & 10 \end{bmatrix}$$

$$\begin{bmatrix} 7.234 & -0.055 \\ 3.046 & 3.696 \end{bmatrix}$$

$$\begin{bmatrix} 25 & 0.02 \\ 0.5 & 10 \end{bmatrix}$$

and from the Routh's array, the respective H'i's are:

$$H'_1 = \begin{bmatrix} 2.5 & 1 \\ 5 & 1 \end{bmatrix}$$

$$H'_2 = \begin{bmatrix} 0.035 & 0.054 \\ 0.197 & 0.025 \end{bmatrix}$$

$$H'_3 = \begin{bmatrix} 2.566 & 0.556 \\ 1.986 & 3.526 \end{bmatrix}$$

$$H'_4 = \begin{bmatrix} 0.076 & -0.039 \\ -0.28 & 0.006 \end{bmatrix}$$

$$H'_5 = \begin{bmatrix} 1.64 & -1.327 \\ -7.73 & 0.74 \end{bmatrix}$$

$$H'_6 = \begin{bmatrix} 0.29 & -0.006 \\ 0.114 & 0.369 \end{bmatrix}$$

The state space representation in Caueer first form is given by equations (91) and (92).

$$\begin{bmatrix} 0.284 & 0.16 & -0.09 & -0.092 & 0.838 & 0.352 \\ 0.36 & 0.296 & -0.099 & -0.189 & 1.562 & 0.339 \\ 0.284 & 0.16 & -0.052 & -0.188 & 1.644 & 0.544 \\ 0.37 & 0.296 & -0.738 & -0.246 & 2.54 & 1.629 \\ 0.284 & 0.16 & -0.052 & -0.188 & 1.967 & 0.043 \\ 0.37 & 0.296 & -0.738 & -0.246 & 0.387 & 1.949 \end{bmatrix} \dot{z} =$$

$$\begin{bmatrix} 1 & 0 & 0 & 0 & 0 & 0 \\ 0 & 1 & 0 & 0 & 0 & 0 \\ 0 & 0 & 1 & 0 & 0 & 0 \\ 0 & 0 & 0 & 1 & 0 & 0 \\ 0 & 0 & 0 & 0 & 1 & 0 \\ 0 & 0 & 0 & 0 & 0 & 1 \end{bmatrix} z + \begin{bmatrix} 1 & 0 \\ 0 & 1 \\ 1 & 0 \\ 0 & 1 \\ 1 & 0 \\ 0 & 1 \end{bmatrix} U$$

(91)

$$y = \begin{bmatrix} 0.035 & 0.054 & | & 0.076 & -0.039 & | & 0.289 & -0.006 \\ & & & & & & & \\ 0.197 & 0.024 & | & -0.28 & 0.006 & | & 0.114 & 0.369 \end{bmatrix} z \quad (92)$$

The reduced fourth and second order model are obtained by partition of the respective matrices in equations (91) and (92). For this case, the fourth order model is unstable and the second order model gives an intolerable error in the steady state portion of the response, so this method is not applicable for this example.

Figure 11 shows the step response for the original system and the reduced second order model.

b. Cauer Matrix Second Form

Performing the respective Routh's Array:

$$\begin{bmatrix} 25 & 0.02 \\ 0.5 & 10 \end{bmatrix} \quad \begin{bmatrix} 55 & 0.2 \\ 1.5 & 20 \end{bmatrix} \quad \begin{bmatrix} 10 & 1 \\ 3.5 & 6 \end{bmatrix} \quad \begin{bmatrix} 1 & 0.5 \\ 1 & 1 \end{bmatrix}$$

$$\begin{bmatrix} 10 & 0.1 \\ 1 & 4 \end{bmatrix} \quad \begin{bmatrix} 1 & 0.2 \\ 2 & 1 \end{bmatrix} \quad \begin{bmatrix} 0 & 0.2 \\ 1 & 0 \end{bmatrix}$$

$$\begin{bmatrix} 52.61 & -0.243 \\ -3.31 & 17.535 \end{bmatrix} \quad \begin{bmatrix} 10.058 & 0.499 \\ 0.995 & 6.04 \end{bmatrix} \quad \begin{bmatrix} 1 & 0.5 \\ 1 & 1 \end{bmatrix}$$

$$\begin{bmatrix} -0.925 & 0.054 \\ 1.437 & -0.397 \end{bmatrix} \quad \begin{bmatrix} -0.199 & 0.096 \\ 0.738 & -0.245 \end{bmatrix}$$

$$\begin{bmatrix} 2.663 & 5.1 \\ 25.5 & 0.39 \end{bmatrix} \quad \begin{bmatrix} 1 & 0.5 \\ 1 & 1 \end{bmatrix}$$

$$\begin{bmatrix} -0.175 & 0.127 \\ 0.756 & -0.269 \end{bmatrix}$$

$$\begin{bmatrix} 1 & 0.5 \\ 1 & 1 \end{bmatrix}$$

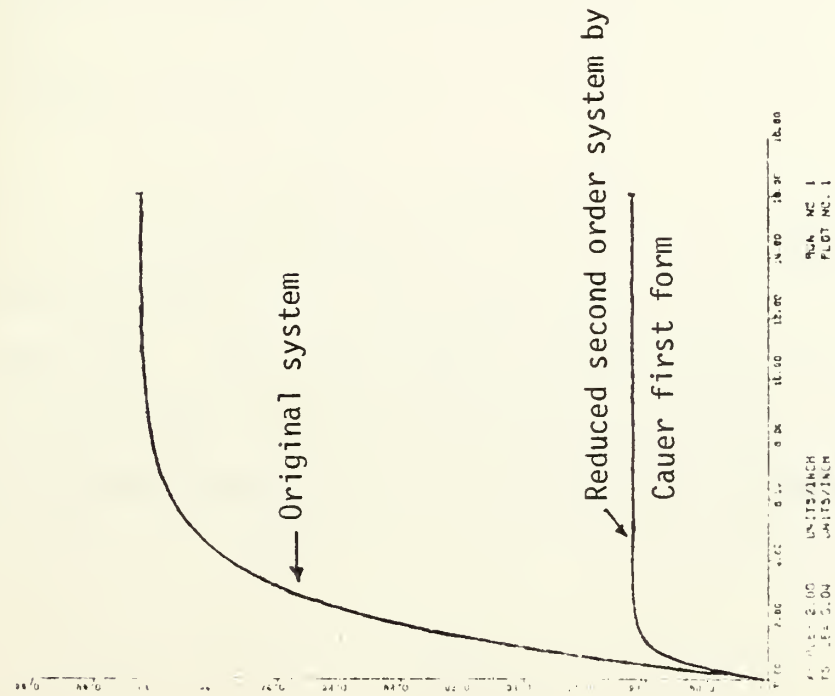

(a)

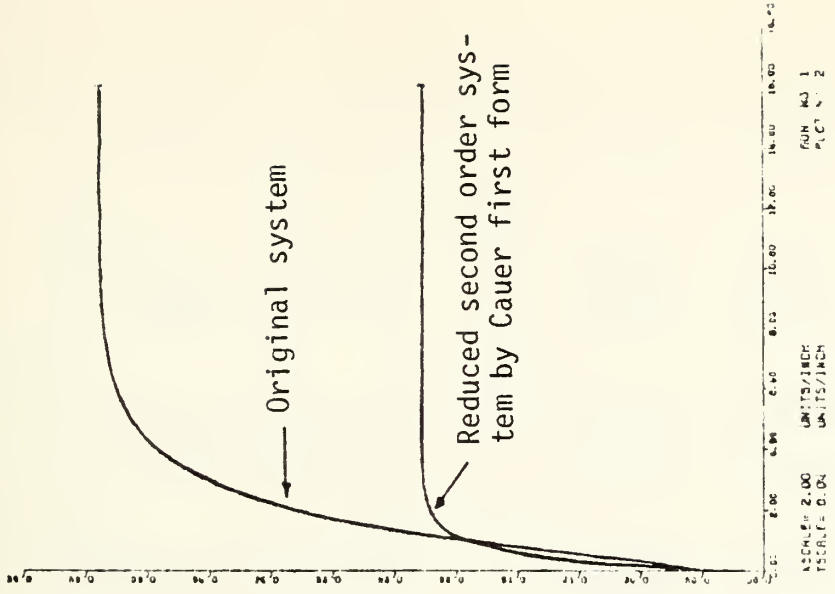

(b)

Figure 11. Outputs for the original sixth order system and reduced second order system by Cauer first form.

and from the Routh's array the respective Hi's are:

$$\begin{aligned}
 H_1 &= \begin{bmatrix} 2.505 & -0.058 \\ -0.2 & 2.505 \end{bmatrix} & H_2 &= \begin{bmatrix} 0.191 & 0.008 \\ 0.033 & 0.229 \end{bmatrix} \\
 H_3 &= \begin{bmatrix} -71.026 & -9.128 \\ -82.527 & -55.455 \end{bmatrix} & H_4 &= \begin{bmatrix} 0.013 & -0.038 \\ 0.083 & 0.065 \end{bmatrix} \\
 H_5 &= \begin{bmatrix} 92.956 & 25.02 \\ 145.353 & 67.357 \end{bmatrix} & H_6 &= \begin{bmatrix} 0.604 & 0.429 \\ 2.05 & -1.293 \end{bmatrix}
 \end{aligned}$$

The state space representation in Cauer second form is given by equations (93) and (94).

$$Z = \begin{bmatrix} -0.476 & -0.008 & -0.039 & 0.098 & 1.632 & -1.15 \\ -0.045 & -0.571 & 0.21 & -0.17 & -5.255 & 3.33 \\ -0.476 & -0.008 & 0.168 & -1.986 & -22.573 & 17.54 \\ -0.045 & -0.571 & -3.263 & 0.322 & 58.535 & -32.97 \\ -0.476 & -0.008 & 0.168 & -1.986 & -17.69 & 10 \\ -0.045 & -0.571 & -3.263 & 0.322 & 8.3 & -8.25 \end{bmatrix} z + \begin{bmatrix} 1 & 0 \\ 0 & 1 \\ 1 & 0 \\ 0 & 1 \\ 1 & 0 \\ 0 & 1 \end{bmatrix} U \quad (93)$$

$$Y = \begin{bmatrix} 0.191 & 0.008 & 0.013 & -0.038 & -0.6 & 0.429 \\ 0.033 & 0.229 & -0.083 & 0.065 & 2.05 & -1.293 \end{bmatrix} z \quad (94)$$

The reduced fourth and second order model are obtained by partition of the respective matrices in equations (93) and (94). For this case like the Cauer first form, the fourth order model is unstable and the second order model offers a good approximation to the step response of the

original system. Figure 12 shows the outputs of the original and reduced second order model for a step input.

c. Cauer Matrix Mixed Form

Performing the respective Routh's Array:

$$\begin{bmatrix} 25 & 0.02 \\ 0.5 & 10 \end{bmatrix} \quad \begin{bmatrix} 55 & 0.2 \\ 1.5 & 20 \end{bmatrix} \quad \begin{bmatrix} 10 & 1 \\ 3.5 & 6 \end{bmatrix} \quad \begin{bmatrix} 1 & 0.5 \\ 1 & 1 \end{bmatrix}$$

$$\begin{bmatrix} 10 & 0.1 \\ 1 & 4 \end{bmatrix} \quad \begin{bmatrix} 1 & 0.2 \\ 2 & 1 \end{bmatrix} \quad \begin{bmatrix} 0 & 0.2 \\ 1 & 0 \end{bmatrix}$$

$$\begin{bmatrix} 26.62 & -4.493 \\ -54.31 & 13.035 \end{bmatrix} \quad \begin{bmatrix} 5.558 & -1 \\ 6 & 4.04 \end{bmatrix}$$

$$\begin{bmatrix} -1.832 & -0.9 \\ -7.2 & -0.81 \end{bmatrix}$$

and from the Routh's array the respective K_i 's and K'_i 's are:

$$K_1 = \begin{bmatrix} 2.505 & -0.058 \\ -0.2 & 2.505 \end{bmatrix}$$

$$K'_1 = \begin{bmatrix} 2.5 & 1 \\ 5 & 1 \end{bmatrix}$$

$$K_2 = \begin{bmatrix} 1.32 & 0.463 \\ 2.24 & 1.079 \end{bmatrix}$$

$$K'_2 = \begin{bmatrix} 0.073 & 0.068 \\ 0.246 & 0.061 \end{bmatrix}$$

$$K_3 = \begin{bmatrix} 10.738 & -6.428 \\ -27.468 & 14.532 \end{bmatrix}$$

$$K'_3 = \begin{bmatrix} 2.33 & -1.365 \\ -6.77 & 2.556 \end{bmatrix}$$

The transfer function for the reduced fourth order system is given in equation (95). For this model the step response is completely stable and the approximation has an error of only 0.5% over the entire response of the system. Figure 13

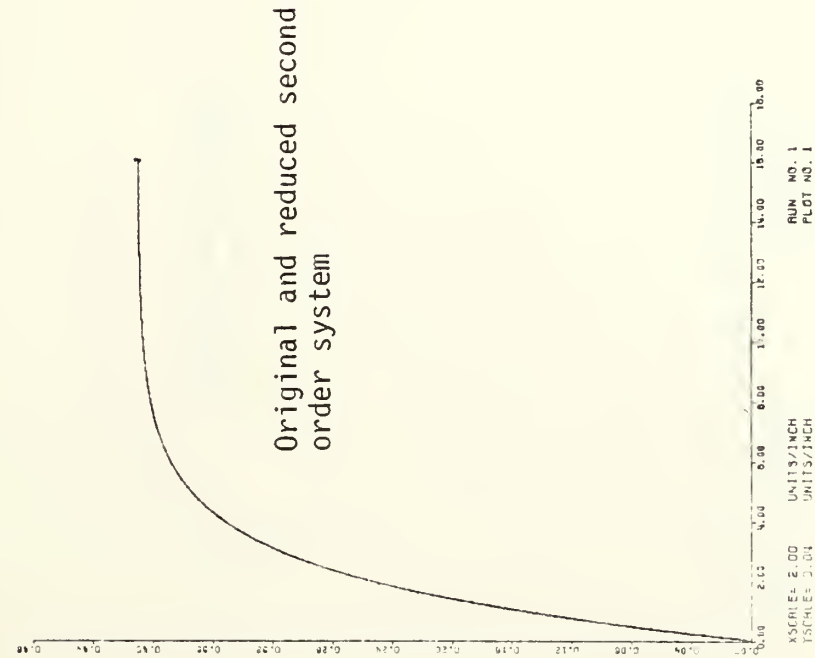

(a)

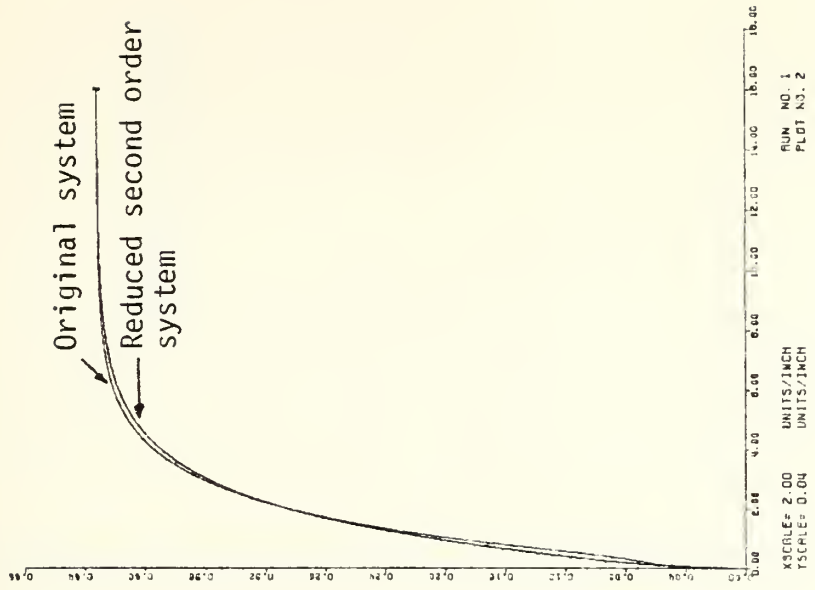

(b)

Figure 12. Outputs for the original sixth and reduced second order system by Cauer second form.

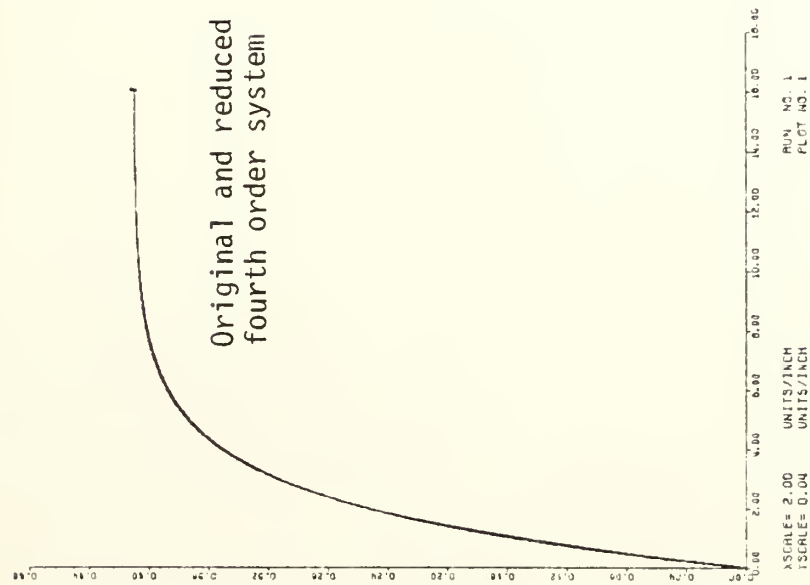

(a)

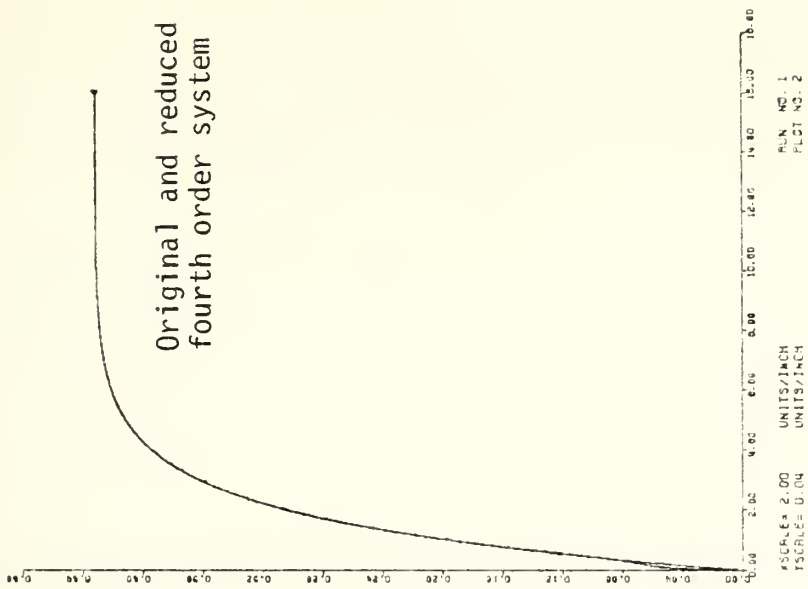

(b)

Figure 13. Outputs for the original sixth and reduced fourth order system by Cauer mixed form.

shows the outputs of the original and reduced fourth order model for a step input.

$$F(s) = \frac{\begin{bmatrix} -0.012s^3 - 0.063s^2 + 1.44s + 0.972 \\ 0.061s^3 + 0.773s^2 + 0.278s + 0.078 \\ 0.012s^3 + 0.173s^2 + 0.068s + 0.022 \\ -0.03s^3 - 0.234s^2 + 1.784s + 0.972 \end{bmatrix} *}{0.03s^4 + 0.9795s^3 + 8.215s^2 + 8.718s + 2.431} \quad (95)$$

III. DERIVATION OF LOWER ORDER SYSTEM FOR THE LINEAR REGULATOR PROBLEM VIA CAUER FORM

A. LINEAR REGULATOR SYSTEM

R. E. Kalman [12] has shown that when a system is described by equations (96) with a performance function given by equation (97)

$$\dot{x} = Ax + Bu \quad (96)$$

$$J = \frac{1}{2} \int [x^T Q x + u^T R u] dt \quad (97)$$

and if the plant is completely controllable then an optimal u^* exists and is given by equation (98)

$$u^* = -Kx \quad (98)$$

where the feedback matrix K for the controller depicted in Figure 14 is a constant matrix as $t \rightarrow \infty$.

In recent papers, Goldman [10] and Aoki [18] have derived a way to obtain near optimal solutions using the "aggregation matrix", to transfer an arbitrary state x to the origin of the state space while minimizing the criterion function given in equation (97).

The present work will show that the reduced order optimal regulator can be obtained where the original system is translated in Cauer form and also a near optimal solution can be found through a mere partition of its optimal solution.

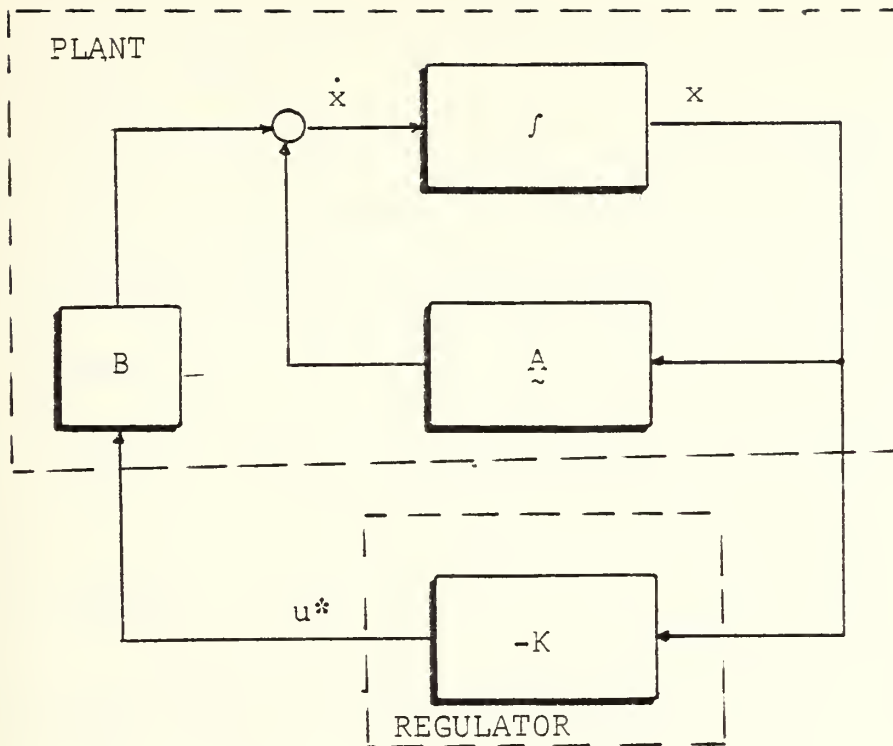

Figure 14. Linear Regulator System

B. THE STATE VARIABLE REPRESENTATION BY CAUER SECOND FORM AND ITS OPTIMAL SOLUTION

It is known that the standard state variable representation of a linear time-invariant system is given by equations (99) and (100).

$$\dot{x} = Ax + Bu \quad (99)$$

$$y = Cx \quad (100)$$

where \dot{x} is a column vector $n \times 1$ given by $[\dot{x}_1, \dot{x}_2, \dots, \dot{x}_n]^T$, A is an $n \times n$ constant coefficients matrix, x is a column vector $n \times 1$ given by $[x_1, x_2, \dots, x_n]^T$, B is an $n \times 1$ constant coefficients

matrix, u is the input, y is the output and C is $1 \times n$ constant coefficients matrix.

Goldman (10), Chin and Shieh (11) have proven that the system given by equations (99) and (100) can be represented in Cauer second form as shown in equation (101) and (102).

$$\dot{z} = Fz + Gu \quad (101)$$

$$y = Mz \quad (102)$$

where,

$$F = PAP^{-1} \quad (103)$$

$$G = PB \quad (104)$$

$$M = CP^{-1} \quad (105)$$

where the matrix P is an $n \times n$ upper triangular matrix and the elements in the triangle are copied directly from the elements of the Routh's array, where the n th row of the P matrix is the $(2n+1)$ th row of the Routh's array and the states variables x and z are related by equation (106).

$$z = Px \quad (106)$$

If the system in (99) and (100) is put in transfer function notation the result is given by (107).

$$T(s) = \frac{a_{21} + a_{22}S + a_{23}S^2 + a_{24}S^3 + \dots + a_{2n}S^{n-1}}{a_{11} + a_{12}S + a_{13}S^2 + a_{14}S^3 + \dots + a_{2n+1}S^n} \quad (107)$$

The Routh's array can be formed as

$$\begin{array}{cccccc}
 a_{11} & a_{12} & a_{13} & \dots & a_{1n} & a_{1,n+1} \\
 a_{21} & a_{22} & a_{23} & \dots & a_{2n} &
 \end{array} \quad (108)$$

and the elements of third, fourth, and subsequent rows can be evaluated from the following algorithm.

$$a_{jk} = a_{j-2, k+1} - f_{j-2} a_{j-1, k+1} \quad \begin{array}{l} j=3,4,\dots,n+1 \\ k=1,2,\dots \end{array} \quad (109)$$

$$f_p = \frac{a_{p,1}}{a_{p+1,1}} \quad p=1,2,\dots,n \quad (110)$$

The elements of the matrix F can be obtained also from equation (111) where $a_{p,1}$ and $a_{p+1,1}$ correspond to the elements of the first column of the Routh's array and then F is formed as shown in equation (111).

$$F = \begin{bmatrix}
 f_2 f_1 & f_4 f_1 & f_6 f_1 & \dots & f_n f_1 \\
 f_2 f_1 & f_4 (f_1 + f_3) & f_6 (f_1 + f_3) & \dots & f_n (f_1 + f_3) \\
 f_2 f_1 & f_4 (f_1 + f_3) & f_6 (f_1 + f_3 + f_5) & \dots & f_n (f_1 + f_3 + f_5) \\
 \vdots & \vdots & \vdots & \vdots & \vdots \\
 f_2 f_1 & f_4 (f_1 + f_3) & f_6 (f_1 + f_3 + f_5) & \dots & f_n (f_1 + f_3 + \dots + f_{n-1})
 \end{bmatrix} \quad (111)$$

The elements of the matrix G correspond to a column vector of $n \times 1$ of 1's and the elements of the matrix M can be formed also by f_p 's where $p=2,4,6,\dots,2n$ as shown in equation (112).

$$M = [f_2, f_4, f_6, \dots, f_{2n}] \quad (112)$$

The performance function given in equation (97) can be translated to Cauer form by using the relationship given in equation (106), i.e.,

$$J_C = \frac{1}{2} \int [z^{*T} Q_C z^* + u^{*T} R U^*] dt \quad (113)$$

where

$$Q_C = P^{-1T} Q P^{-1} \quad (114)$$

and the optimal u^* is given by equation (115).

$$u^* = -K_C z^* \quad (115)$$

where

$$K_C = K P^{-1} \quad (116)$$

So the equivalent system in Cauer form given in Figure 14 can be represented by Figure 15.

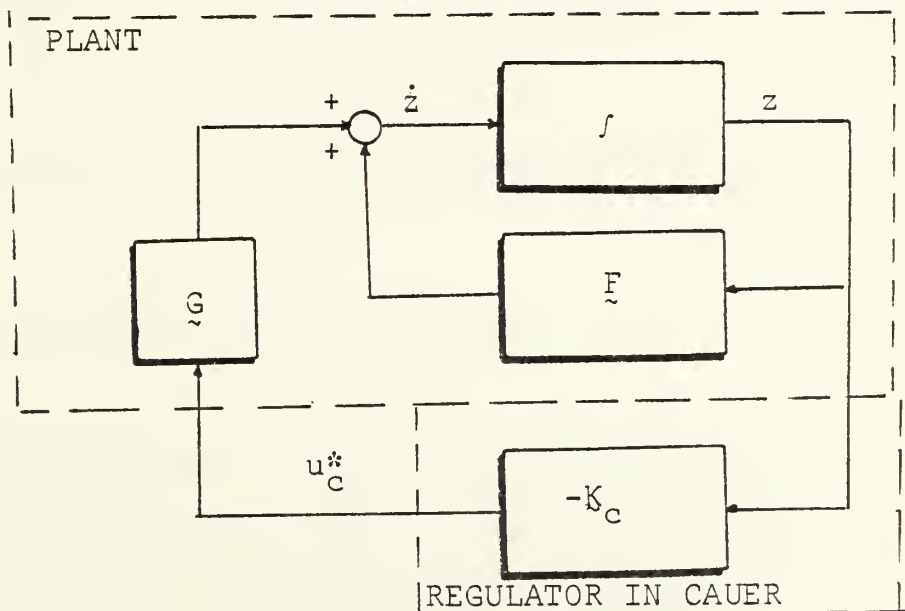

Figure 15. Linear Regulator in Cauer Form.

Note that K_c is the feedback gain matrix of the Cauer system and u^* is the optimal control law of both systems (Figure 14 and 15).

From the theory of optimal control, z^* and u^* are found by solving the set of necessary conditions:

$$\dot{z}^* = \frac{\partial H}{\partial \tilde{p}^*} (z^*, u^*, \tilde{p}^*, t)$$

$$\dot{\tilde{p}}^* = - \frac{\partial H}{\partial z^*} (z^*, u^*, \tilde{p}^*, t)$$

$$0 = \frac{\partial H}{\partial u^*} (z^*, u^*, \tilde{p}^*, t)$$

$$0 = \frac{\partial^2 H}{\partial u^{*2}} (z^*, u^*, \tilde{p}^*, t)$$

} for all
 $t \in [t_0, t_f]$

(117)

Where the function H is called the Hamiltonion and is defined by:

$$H(z, u, \tilde{p}, t) = \frac{\Delta}{2} [z^T Q_c z + u^T R U] + \tilde{p}^T [Fz + Gu]$$

(118)

and \tilde{p} is the Lagrange multiplier or Costate state.

Substituting equation (118) into equation (117), the canonical system in equation (119) is formed.

$$\begin{bmatrix} \dot{z}^* \\ \dot{\tilde{p}}^* \end{bmatrix} = \begin{bmatrix} F & -GR^{-1}G^T \\ -Q_c & -F^T \end{bmatrix} \begin{bmatrix} z^* \\ \tilde{p}^* \end{bmatrix}$$

(119)

Fortunately, for the Optimal Regulator problem, it is not necessary to solve these equations. Kalman [12], Tyler, J.S. and Tuteur, F.B. [19] have shown that when the optimal control u^* is generated by equation (115), the solution for K_c is obtained from equation (120) where the matrix, T , is the solution to equation (121) in steady state.

$$K_c = R^{-1}G^T T \quad (120)$$

$$0 = F^T T + TF - TGR^{-1}G^T T + Q_c \quad (121)$$

Equation (121) is the steady state form of the Ricatti equation.

For the single input case the weighting matrix, R , is a scalar. When this is the case, a lower order optimal linear regulator can be found just by mere partition of F , G , M , Q_c and K_c matrices as shown in equation (122). Hence the new system is depicted in Figure 16.

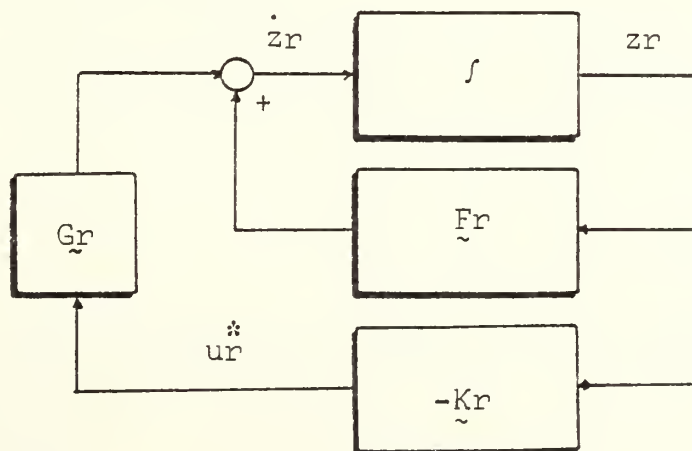

Figure 16 . Reduced Linear Regulator in Cauer Form

$$F = \begin{bmatrix} F_{11} & F_{12} & F_{13} \dots F_{1n} \\ F_{21} & F_{22} & F_{23} \dots F_{2n} \\ \dots & \dots & \dots \\ F_{n1} & F_{n2} & F_{n3} \dots F_{nn} \end{bmatrix} \quad G = \begin{bmatrix} 1_1 \\ 1_2 \\ \cdot \\ \cdot \\ 1_n \end{bmatrix}$$

$$M = [f_2 \quad f_4 \quad \vdots \quad f_6 \dots f_{2n}]$$

$$K_c = [k_{c11} \quad k_{c12} \quad \vdots \quad k_{c1n}]$$

$$Q_c = \begin{bmatrix} q_{c11} & q_{c12} & \dots & q_{c1n} \\ q_{c21} & q_{c22} & \dots & q_{c2n} \\ \dots & \dots & \dots & \dots \\ q_{cn1} & q_{cn2} & \dots & q_{cnn} \end{bmatrix}$$

(122)

The reduction scheme outline above has left u_c^* and u_r^* unchanged. Therefore, u_r^* is the suboptimal solution for all three systems, that is the original system, the transformed system and the reduced system.

C. THE REDUCED ORDER SOLUTION

Based on equation (122), the reduced system is given by

$$\dot{z}_r = F_r z + G_r u \tag{123}$$

$$y = M_r z \tag{124}$$

where F_r , G_r and M_r are the partitions of the matrices F , G and M respectively.

Goldman [10] has shown that the original system is related to the reduced order model by the following equations:

$$\dot{z}_r = \epsilon A \epsilon^+ z_r + \epsilon B u \quad (125)$$

$$y = C \epsilon^+ z_r \quad (126)$$

$$x = \epsilon^+ z_r \quad (127)$$

$$z_r = \epsilon x \quad (128)$$

where the matrices ϵ and ϵ^+ are partition of the P and P^{-1} matrices in rectangular form respectively, such that ϵ is of order $(r \times n)$ and ϵ^+ is $(n \times r)$, where, n , is the order of the original system and, r , is the order of the reduced system.

From equation (127) and (98) it is easy to show that

$$u^* = K \epsilon^+ z_r \quad (129)$$

then

$$K r = K \epsilon^+ \quad (130)$$

or

$$K = K r \epsilon \quad (131)$$

Note that from equations (98) and (106)

$$K_c = K P^{-1} \quad (132)$$

or

$$K = K_c P \quad (133)$$

Then from equations (130) and (133)

$$K_r = K_c I_r \quad (134)$$

where

$$I_r = P \epsilon^+ \quad (135)$$

The matrix I_r has dimension $(n \times r)$ and is a special type of identity matrix where the last $(n-r)$ rows are zeros and the first $r \times r$ components correspond to the identity matrix. In the same way, it is possible to show that the different relationships that exist for the weighting matrices, Q , Q_c and Q_r are given in equations (136), (137), (138) and (139).

$$Q_c = P^{-1T} Q P^{-1} \quad (136)$$

$$Q_r = \epsilon^{+T} Q \epsilon^+ \quad (137)$$

$$Q_r = \epsilon^{+T} P^T Q_c P \epsilon^+ \quad (138)$$

$$Q_r = I_r^T Q_c I_r \quad (139)$$

1. Example 3.1

The transfer function of a system is given in equation (140). It is desired to control the system in such a way that a performance function given in equation (141) is minimized. Due to the systems complexity, a near optimal solution is desired.

$$H(s) = \frac{1}{s^3 + 6.1s^2 + 5.6s + 0.5} \quad (140)$$

$$J = \int \frac{1}{2} [x^T Q x + U^T R U] dt \quad (141)$$

where

$$Q = \begin{bmatrix} 5 & 0 & 0 \\ 0 & 4 & 0 \\ 0 & 0 & 1 \end{bmatrix} \quad R = 1$$

From the transfer function

$$A = \begin{bmatrix} 0 & 1 & 0 \\ 0 & 0 & 1 \\ -0.5 & -5.6 & -6.1 \end{bmatrix} \quad B = \begin{bmatrix} 0 \\ 0 \\ 1 \end{bmatrix} \quad C = [1 \ 0 \ 0]$$

The Routh's array

$$\begin{array}{cccc} 0.5 & 5.6 & 6.1 & 1.0 \\ 1.0 & 0.0 & 0.0 & \\ \hline 5.6 & 6.1 & 1.0 & \\ -1.09 & -0.179 & & \\ \hline 5.182 & 1.0 & & \\ 0.932 & & & \\ \hline 1.0 & & & \end{array}$$

From the Routh's array

$$P = \begin{bmatrix} 5.6 & 6.1 & 1.0 \\ 0 & 5.182 & 1.0 \\ \hline 0 & 0 & 1.0 \end{bmatrix}$$

(142)

$$P^{-1} = \begin{bmatrix} 0.179 & -0.2102 & 0.032 \\ 0 & 0.193 & -0.192 \\ 0 & 0 & 1.0 \end{bmatrix} \quad (143)$$

then

$$\epsilon = \begin{bmatrix} 5.6 & 6.1 & 1.0 \\ 0 & 5.182 & 1.0 \end{bmatrix} \quad (144)$$

$$\epsilon^+ = \begin{bmatrix} 0.179 & -0.2102 \\ 0 & 0.193 \\ 0 & 0 \end{bmatrix} \quad (145)$$

The Q_c matrix obtained from equation (136) is

$$Q_c = \begin{bmatrix} 0.159 & -0.188 & 0.029 \\ -0.188 & 0.372 & -0.183 \\ 0.029 & -0.183 & 1.154 \end{bmatrix} \quad (146)$$

The F_c , G_c and M_c matrices from equations (103), (104) and (105) are

$$F_c = \begin{bmatrix} -0.089 & 0.105 & 0.015 \\ -0.089 & -0.978 & 0.139 \\ -0.089 & -0.978 & -5.031 \end{bmatrix} \quad (147)$$

$$G_c = \begin{bmatrix} 1 \\ 1 \\ -1 \\ 1 \end{bmatrix} \quad M_c = [0.1786-0.211 \quad 0.032]$$

The reduced system is given by equation (148) and the corresponding matrices that describe the system in equation (149).

$$H_4(s) = \frac{-0.0316s+0.193}{s^2+1.065s+0.0965} \quad (148)$$

$$F_r = \begin{bmatrix} -0.089 & 0.105 \\ -0.089 & -0.978 \end{bmatrix}$$

$$G_r = \begin{bmatrix} 1 \\ 1 \end{bmatrix} \quad M_r = [0.1786-0.211]$$

$$Q_r = \begin{bmatrix} 0.159 & -0.188 \\ -0.188 & 0.372 \end{bmatrix} \quad (149)$$

The computer solution for the three systems for the feedback gain are shown in Table I.

TABLE I

SYSTEMS	OPTIMAL FEEDBACK MATRIX K		
	ORIGINAL	1.79128425	2.087266
CAUER FORM	0.319649369	0.0243818	0.06619982
REDUCED CAUER FORM	0.31965241	0.02258695	

Table II shows values found from the reduced system back to Cauer form and original system with the equation (131) and (132).

TABLE II

SYSTEMS	NEAR OPTIMAL FEEDBACK MATRIX		
ORIGINAL	1.7908	2.067	0.342
CAUER FORM	0.31965	0.022586	0.0
REDUCED CAUER FORM	0.31965	0.022586	

Note that a near optimal feedback matrix is obtained directly from equation (131) but not to the Cauer system since the reduction technique discarded the last terms.

Figure 17 shows the step response for the optimal and reduced linear regulator. Figure 18 shows the optimal and suboptimal control laws. Figure 19 shows the step response for the optimal and suboptimal linear regulator.

2. Example 3.2

The methodology just developed is applied to a simple model of a nuclear reactor power generator [20, 21].

The heat generating process of a nuclear reactor is dependent upon the mechanism called fission (a fragmentation of matter). The power generated by this process is directly related to the population of neutrons, $n(t)$ and can be described by the following differential equation (developed from a diffusion balance equation).

FIG. 17 - EXAMPLE 3.1 STEP RESPONSE
OPTIMAL AND REDUCED LINEAR REGULATOR

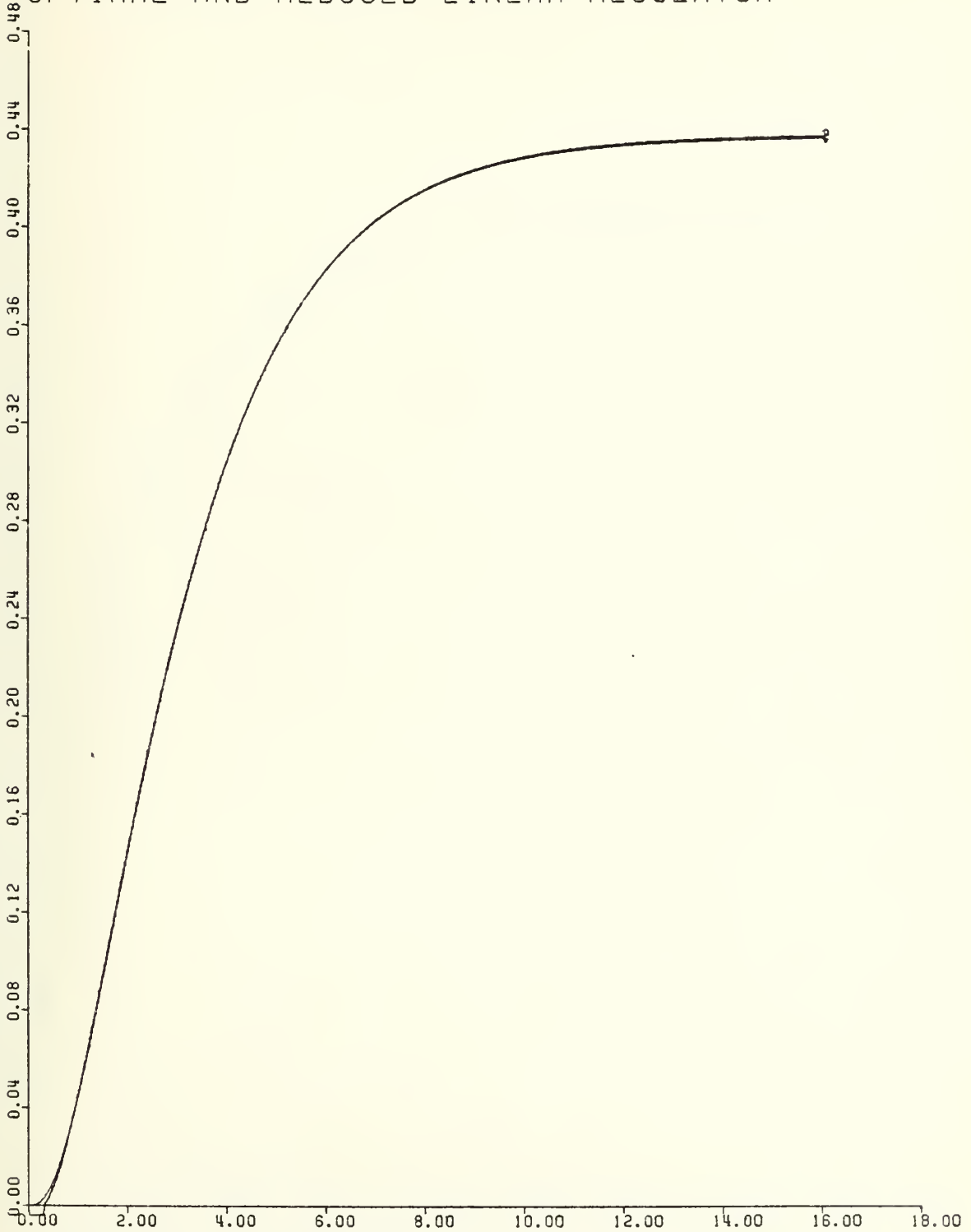

XSCALE= 2.00
YSCALE= 0.04

UNITS/INCH
UNITS/INCH

RUN NO. 1
PLOT NO. 1

FIG. 18 - EXAMPLE 3.1 - NEAR OPT. SOLUTION
OPTIMAL AND SUBOPTIMAL CONTROL LAWS

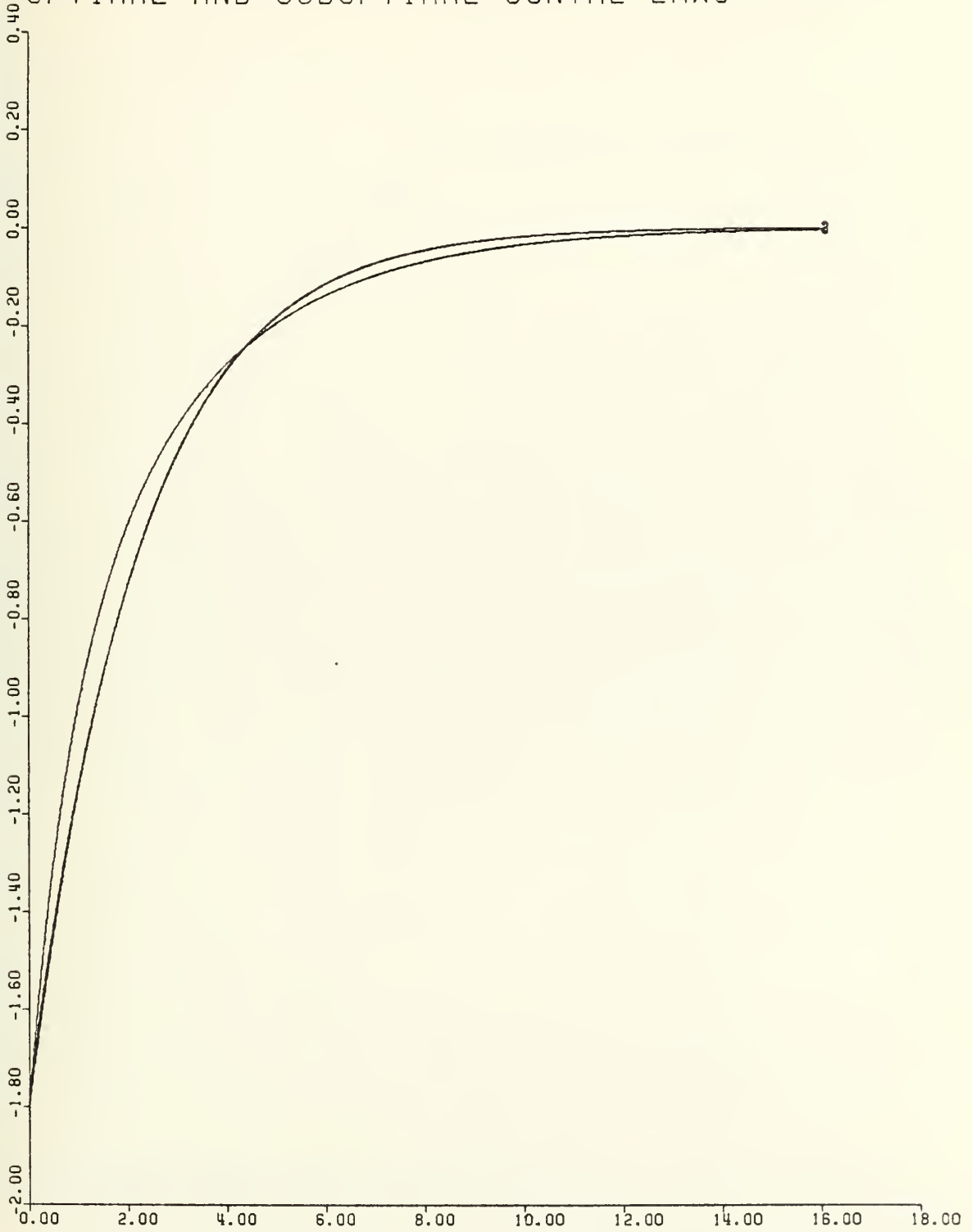

XSCALE= 2.00 UNITS/INCH
YSCALE= 0.20 UNITS/INCH

RUN NO. 1
PLOT NO. 1

FIG. 19 - EXAMPLE 3.1 STEP RESPONSE
OPTIMAL AND SUBOPTIMAL LINEAR REGULATOR

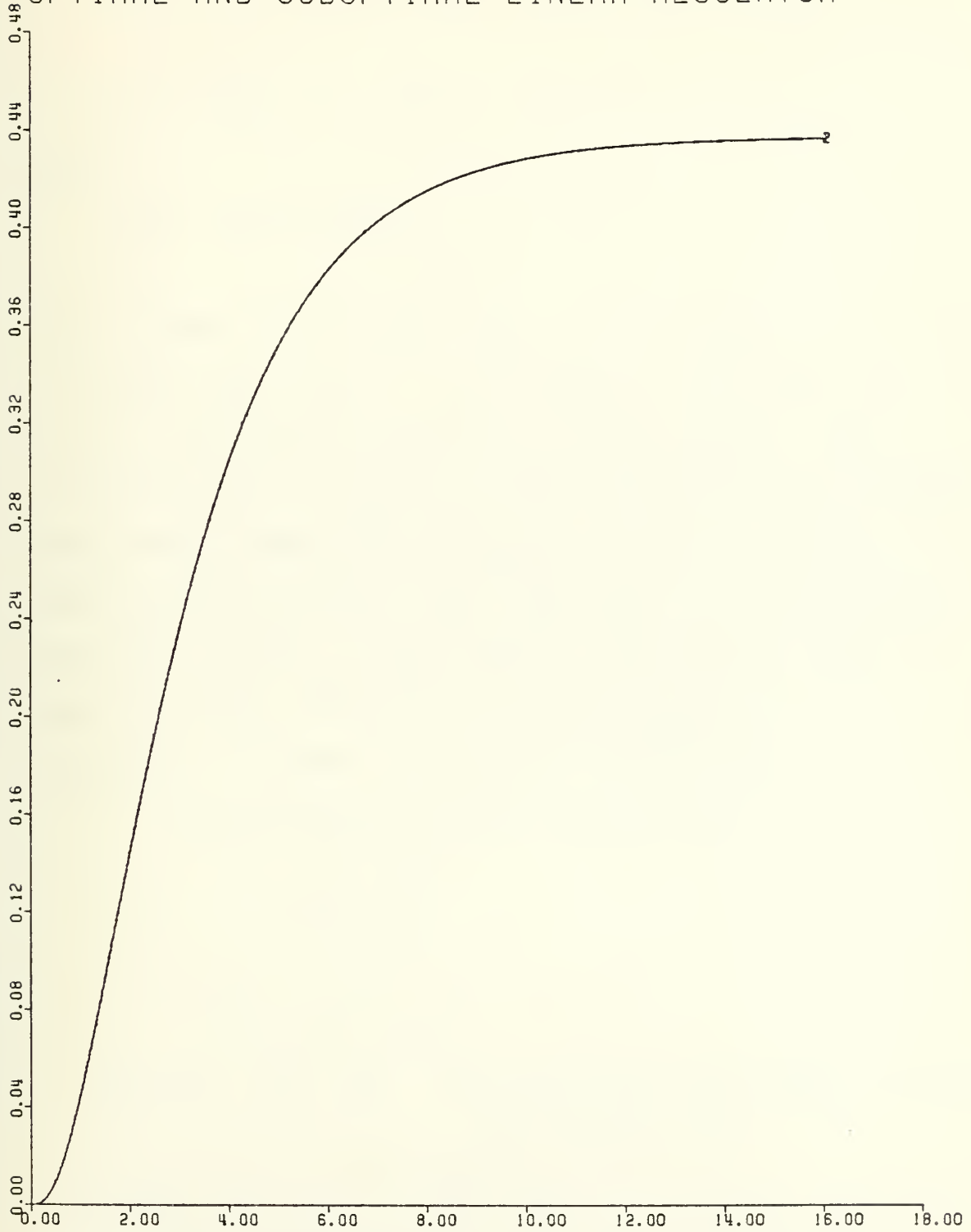

XSCALE= 2.00
YSCALE= 0.04

UNITS/INCH
UNITS/INCH

RUN NO. 1
PLOT NO. 1

$$\dot{n}(t) = \left(\frac{\delta k(t) - \beta}{l} \right) n(t) + \lambda c(t) \quad (150)$$

$$\dot{c}(t) = \left(\frac{\beta}{l} \right) n(t) - \lambda c(t) \quad (151)$$

where

$$\delta k(t) = \delta k_c(t) - \alpha n(t) \quad (152)$$

The variable $\delta k(t)$ is the input to the process and is given the name "reactivity". It is clear by inspection that $\delta k(t) < \beta$ for stable system (in a linear sense). The variable $c(t)$ is a measure of the concentration of fragments (precursors) that produce delayed neutrons according to a time delay (l/λ) called the "half-life" of the precursor. The input, $\delta k_c(t)$, is the control (reactivity) that is associated with the control rod position and, α , is a temperature feedback (reactivity) coefficient.

The parameters for this system are:

$$\alpha = 10^{-5} \text{ kw}^{-1}$$

$$l = 10^{-3} \text{ sec.}$$

$$\beta = 0.0065$$

$$\lambda = 0.1 \text{ sec.}^{-1}$$

at $t=0$ $n(0)=10\text{kw}$ (as the operating output in steady state conditions)

The control problem is stated as:

Find the Optimal Control Policy $u^*(t)$ that will transfer the power level $n(t)$ from the operating level

$n(0) = 10\text{kw}$ to a new level $n(t) = 50\text{ kw}$ where

$$u(t) = \delta k c(t) \tag{153}$$

using the performance measure given in equation (97) where

$$Q = \begin{bmatrix} 10^{-6} & 0 & 0 \\ 0 & 0 & 0 \\ 0 & 0 & 25 \end{bmatrix} \tag{154}$$

$$R = 1$$

and compare this solution to the near optimal one obtained from the reduced order model.

From the state of the problem the following diagram is drawn

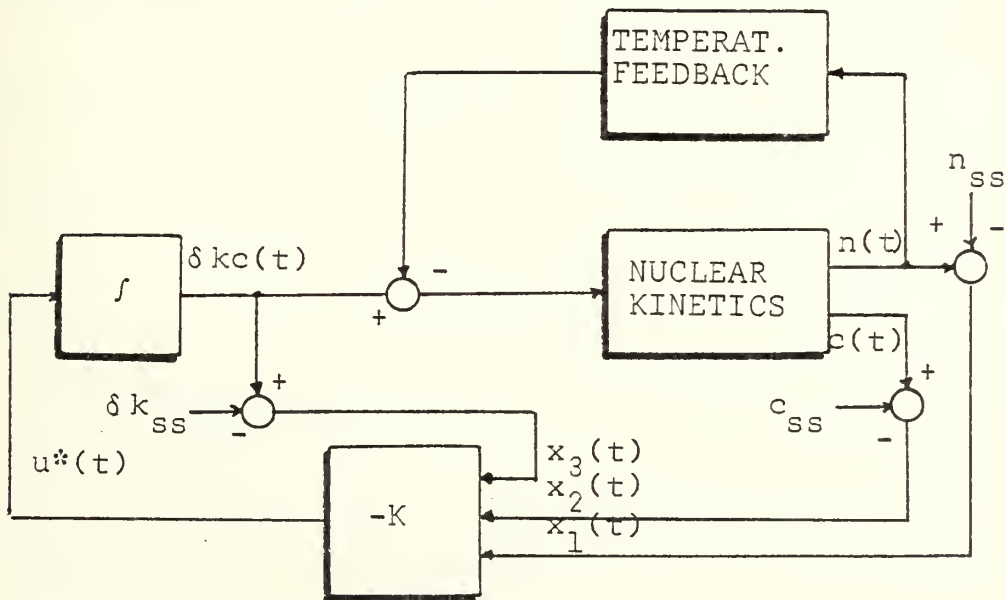

Figure 20. Block Diagram Optimal Control of a Nuclear Reactor.

The double subscript, ss, means steady state and the new definition of state variables are:

$$x_1(t) = n(t) - n_{ss} \quad (155)$$

$$x_2(t) = c(t) - c_{ss} \quad (156)$$

$$x_3(t) = \delta k(t) - \delta k_{ss} \quad (157)$$

The steady state conditions are

$$\dot{n}(t) = 0 \quad (158)$$

$$\dot{c}(t) = 0 \quad (159)$$

$$\delta k(t) = 0 \quad (160)$$

The initial conditions at $n(t) = 50\text{kw}$ are:

from the state variables definitions, equations (155), (156) and (157) and equations (150), (151) and (152).

$$c(t) = \frac{\beta}{1-\lambda} n(t) - \dot{c}(t) \quad (161)$$

$$c(0) = \frac{\beta}{1-\lambda} n(0) \quad (162)$$

$$c(0) = 640 \quad (163)$$

$$x_2(0) = c(0) - c_{ss} \quad (164)$$

$$x_2(0) = -2560 \quad (165)$$

$$\delta k(t) = \alpha n(t) - \lambda_1 \frac{c(t)}{n(t)} + \beta \quad (166)$$

$$\delta k(0) = \alpha n(0) - \lambda_1 \frac{c(0)}{n(0)} + \beta \quad (167)$$

$$\delta k(0) = 10^{-4} \quad (168)$$

$$\delta k_{ss} = dn_{ss} - \lambda 1 \frac{c_{ss}}{n_{ss}} + \beta \quad (169)$$

$$\delta k_{ss} = 5 \times 10^{-4} \quad (170)$$

$$x_3(0) = \delta k(0) - \delta k_{ss} \quad (171)$$

$$x_3(0) = -4 \times 10^{-4} \quad (172)$$

$$x_1(0) = n(0) - n_{ss} \quad (173)$$

$$x_1(0) = -40 \quad (174)$$

then

$$x(0) = \begin{bmatrix} x_1(0) \\ x_2(0) \\ x_3(0) \end{bmatrix} = \begin{bmatrix} -40 \\ -2560 \\ -4 \times 10^{-4} \end{bmatrix} \quad (175)$$

and the optimal control law $U^*(t)$ will be

$$u^*(t) = -Kx(t)$$

same as given in equation (98). The system in variable form is given by equations (99) and (100). Since equations (150) through (157) are non-linear linearization is required (see appendix A). The linearized system is represented by

$$\dot{x}(t) = \begin{bmatrix} -\frac{1}{l}(\alpha n_{ss} + \beta) & \lambda & \frac{n_{ss}}{l} \\ \beta/l & -\lambda & 0 \\ 0 & 0 & 0 \end{bmatrix} x + \begin{bmatrix} 0 \\ 0 \\ 1 \end{bmatrix} u \quad (176)$$

$$y(t) = [1 \quad 0 \quad 0]x(t) \quad (177)$$

where

$$A = \begin{bmatrix} -6.9 & 0.1 & 5 \times 10^4 \\ 6.4 & -0.1 & 0 \\ 0 & 0 & 0 \end{bmatrix} \quad (178)$$

$$B = \begin{bmatrix} 0 \\ 0 \\ 1 \end{bmatrix} \quad (179)$$

$$C = [1 \quad 0 \quad 0] \quad (180)$$

Solving the Riccati equations, the matrix K is given by equation (181).

$$K = [2.5 \times 10^{-4} \quad 8 \times 10^{-6} \quad 7.05] \quad (181)$$

The transfer function for the optimal system will be:

$$H(s) = \frac{5 \times 10^4 (s + 0.1)}{s^3 + 14.05s^2 + 61.9s + 4.16} \quad (182)$$

The Routh's array for this system is:

4.16 61.9 14.05 1.0

5000 50000 0.0

20.3 14.05 1.0

46539 -246.3

14.157 1.0

-3533.58

1.0

From the Routh's array

$$P = \begin{bmatrix} 20.3 & 14.05 & 1.0 \\ 0.0 & 14.157 & 1.0 \\ \hline 0.0 & 0.0 & 1.0 \end{bmatrix} \quad (183)$$

$$P^{-1} = \begin{bmatrix} 0.049 & -0.049 & -0.0004 \\ 0.0 & 0.07 & -0.07 \\ 0.0 & 0.0 & 1.0 \end{bmatrix} \quad (184)$$

and the rectangular partition of P and P^{-1} matrices give

$$\epsilon = \begin{bmatrix} 20.3 & 14.05 & 1.0 \\ 0.0 & 14.157 & 1.0 \end{bmatrix} \quad (185)$$

$$\epsilon^+ = \begin{bmatrix} 0.049 & -0.049 \\ 0.0 & 0.07 \\ 0.0 & 0.0 \end{bmatrix} \quad (186)$$

and from equations (125) and (126) the reduced second order suboptimal system will be

$$\dot{z}_r(t) = \begin{bmatrix} -0.205 & -2.735 \\ -0.205 & -4.169 \end{bmatrix} z_r(t) + \begin{bmatrix} 1 \\ 1 \end{bmatrix} u(t) \quad (187)$$

$$y(t) = [246.305 \quad 3287.5] z_r(t) \quad (188)$$

The corresponding transfer function is given in equation (189).

$$H_{rop}(s) = \frac{3533.58s + 353.17}{s^2 + 4.3738s + 0.294} \quad (189)$$

In Figure 21 is shown the step response for the original optimal and reduced suboptimal system.

FIG. 21 - EXAMPLE 3.2 - STEP RESPONSE NUC. REAC.
ORIGINAL AND REDUCED OPTIMAL SYSTEMS

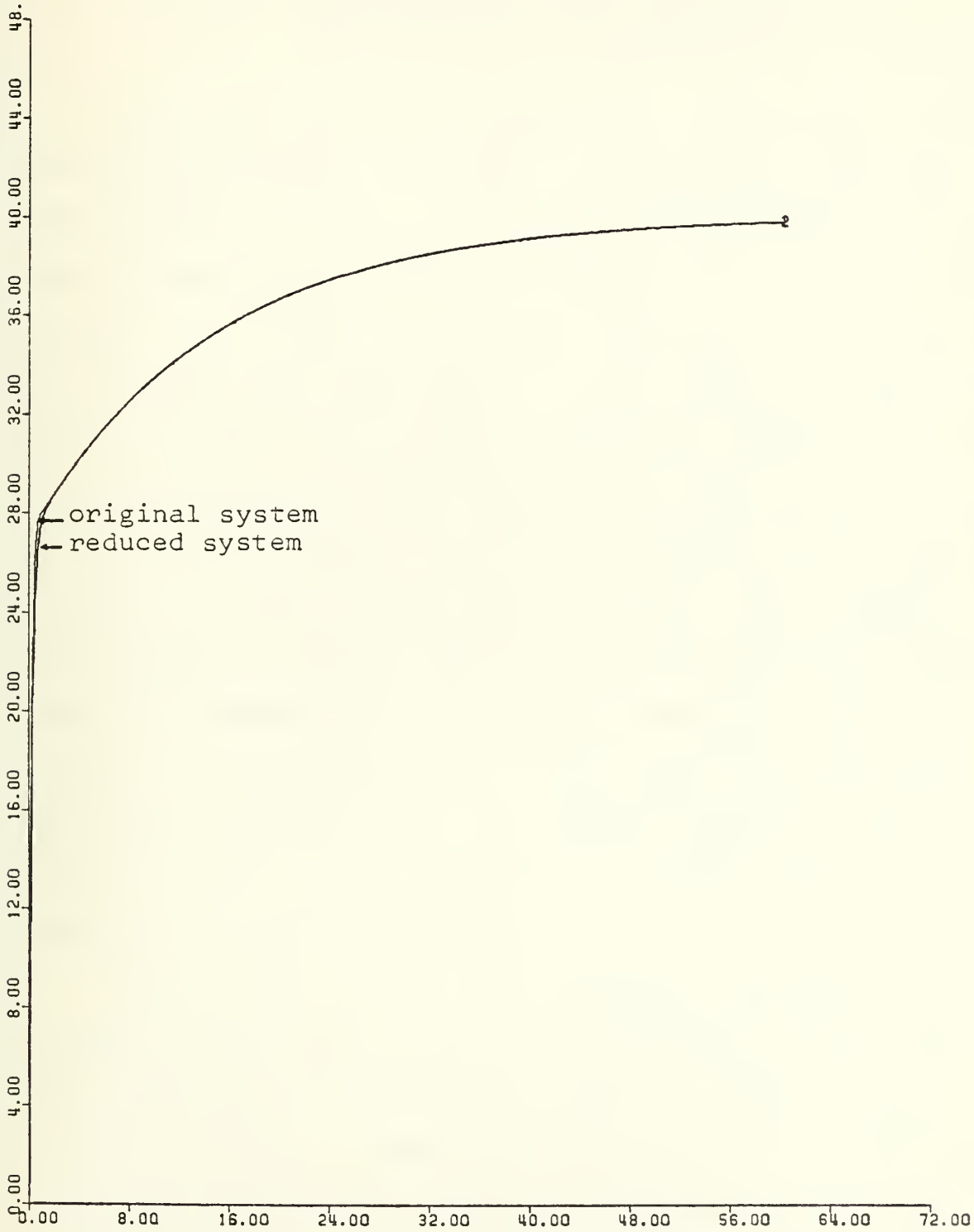

XSCALE= 8.00 UNITS/INCH
YSCALE= 4.00 UNITS/INCH

RUN NO. 1
PLOT NO. 1

IV. CONCLUSIONS AND RECOMMENDATIONS

Comparative analysis of Cauer forms methodology for multivariable system reduction is established. The developed methodology is based on the Cauer matrix generalized form, which offers the closest approximation to the original system. The proposed methodology and because of the nature of the Cauer mixed form shows it to be superior to any other method proposed to date since it provides satisfactory results for both the transient and the steady state portion of the system response. The methodologies in state space as well as in the S domain are developed. For the basis of comparison, reduced order models using the three Cauer forms are obtained for two different examples. The results clearly show the superiority of the Cauer mixed form over the entire frequency range of system's response. The proposed methodology is algorithmic therefore, it is amenable to digital computation.

A lower order optimal linear regulator can be obtained by mere translation of the original system to Cauer second form and their partition of the different matrices as shown in Section III-B. A suboptimal feedback matrix for the original system can be obtained by multiplication of the lower feedback optimal matrix by the rectangular partition

of the matrix P . The responses of both systems, the original and the reduced, as well as optimal and sub-optimal systems are extremely close.

The results presented here are encouraging, there is a distinct need for future research, in particular in the reduction of systems with any given number of inputs or outputs.

APPENDIX A

Linearization of Multivariable Systems

Let equations (A-1) and (A-2) be the state variable modeling

$$\dot{x} = F(x,u) \quad (A-1)$$

$$y = g(x,u) \quad (A-2)$$

For the system described by equations (A-1) and (A-2) is operating at steady state conditions (constant input u_{ss} , producing constant state x_{ss} and constant output y_{ss}). The combination of these produces

$$0 = f(x_{ss}, u_{ss}) \quad (A-3)$$

$$y_{ss} = g(x_{ss}, u_{ss}) \quad (A-4)$$

If the system is perturbed by either drawing the states or the inputs, the system motion satisfies

$$\delta \dot{x} = F(x_{ss} + \delta x, u_{ss} + \delta u) \quad (A-5)$$

$$y_{ss} + \delta y = g(x_{ss} + \delta x, u_{ss} + \delta u) \quad (A-6)$$

Both functions, F and g can be expanded in a Taylor series about the points (x_{ss}, u_{ss}) resulting in the following representation of the system equations.

$$\dot{x}_{ss} + \delta \dot{x} = F(x_{ss}, u_{ss}) + A\delta x + B\delta u + \alpha(\delta x, \delta u) \quad (A-7)$$

$$y_{ss} + \delta y = g(x_{ss}, u_{ss}) + C\delta x + D\delta u + \beta(\delta x, \delta u) \quad (A-8)$$

where:

A = nxn matrix

B = nxm matrix

C = vxn matrix

D = vxm matrix

n = order of the system, m = number on inputs, v=number of outputs.

The functions $\alpha(\delta x, \delta u)$ and $\beta(\delta x, \delta u)$ represents all second order and higher terms in the Taylor series expansion. Substitution of equations (A-1) and (A-2) evaluated at (x_{ss}, u_{ss}) and neglecting second order terms and higher terms, yields the following perturbed equations of motion

$$\delta \dot{x} = A\delta x + B\delta u \quad (A-9)$$

$$\delta y = C\delta x + D\delta u \quad (A-10)$$

The two equations above approximate the dynamic behavior of the system about the operating point (x_{ss}, u_{ss}) . The elements of the motion A, B, C and D are given by

$$A_{ij} \cong \frac{\delta \dot{x}_i}{\delta x_j} \quad i = 1, 2, \dots, n \quad j = 1, 2, \dots, n$$

$$B_{ij} \cong \frac{\delta \dot{x}_i}{\delta u_j}$$

$$C_{ij} \cong \frac{\delta y_i}{\delta x_j}$$

$$D_{ij} \cong \frac{\delta y_i}{\delta u_j}$$

The representation of equations (A-9) and (A-10) is given by the following block diagram.

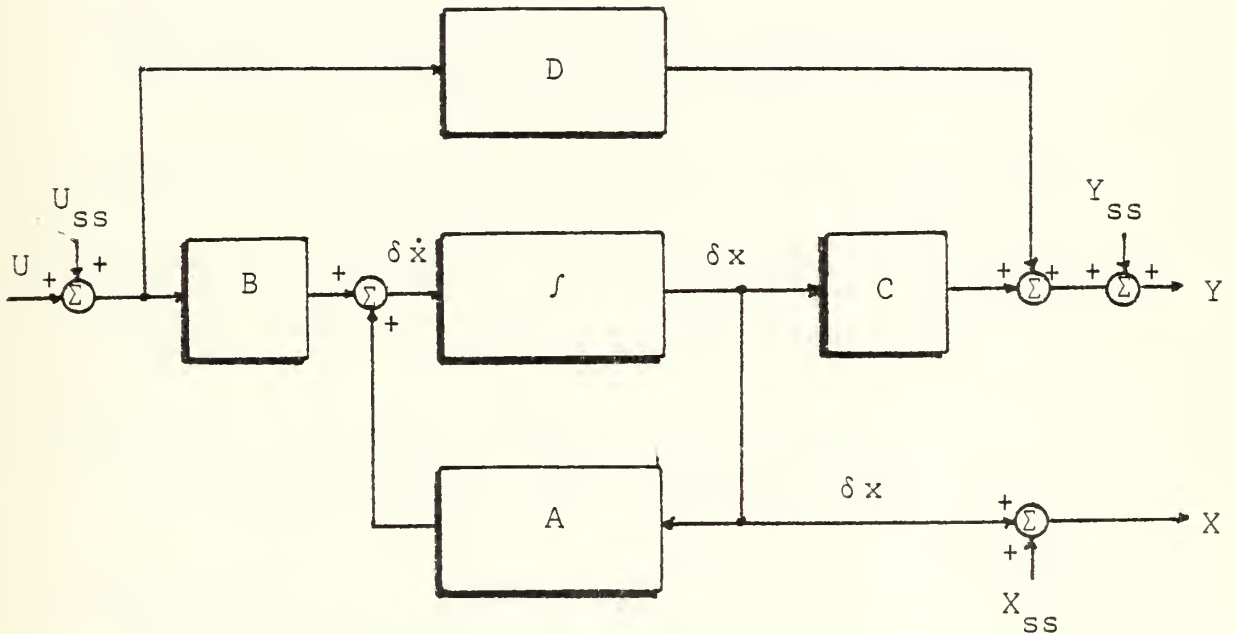

Figure A-1. Block Diagram of a Linear Model.

LIST OF REFERENCES

1. Chen, C. F., "Model Reduction of Multivariable Control System by Means of Matrix Continued Fraction", Int. J. Contr., Vol. 20, No. 2, pp. 225-238, 1974.
2. Meier, L., and Luenberger, D.D., "Guidance and Control Conference", Proc. Joint Autom. Contr. Conf., p. 728, 1966.
3. Shieh, L.S. and Wei, Y. J., "Mixed Method for Reduction of Multivariable System with Various Inputs and Outputs" (Corresp.), Proc. IEEE, Vol. 122, No. 10, pp. 1159-1160, October 1975.
4. Colfe, H. R. and Healey, M., "Continued-fraction Model Reduction Techniques for Multivariable Systems", Inst. Electr. Engr (Proceeding Control & Science), Vol. 121, No. 5, pp. 393-395, May 1974.
5. Shieh, L.S., Navarro, J. M., and Yates, R., "Multi-variable Systems Identification via Frequency Responses", Proceedings of the IEEE, Vol. 62, No. 8, pp. 1169-1171, August 1974.
6. Wilson, D. A., "Optimum Solution of Model Reduction Problem", Proc. IEEE, Vol. 117, No. 6, June 1970.
7. Shieh, L.S. and Gaudiano, F.F., "Matrix Continued Fraction Expansion and Inversion by the Generalized Matrix Routh Algorithm", Int. J. Contr., Vol. 20, No. 5, pp. 727-737, 1974.
8. Goldman, M. J. and Leondes, C. T., "Truncation of the Mixed Cauer Form the Best Approximation in a Definite Mathematical Sense", Int. J. Contr., Vol. 25, No. 6, pp. 979-982, 1977.
9. Luenberger, D. G., "Observing the States of a Linear System", IEEE Trans. Mil. Electronics, Vol. MIL-8, pp. 74-80, 1964.
10. Goldman, M., Generalized Model for Linear System Reduction, M.S. Thesis, Univ. Houston, Texas, May 1973.
11. Chen, C. F. and Shieh, L.S., "Continued Fraction Inversion by Routh Algorithm", IEEE Transaction on Circuits Theory, Vol. CT16 No. 2, May 1969.
12. Kalman, R. E., "Mathematical Description of Linear Dynamical Systems", SIAM Journal on Control, Vol. 1, No. 2, pp. 152-192, 1963.

13. Kirk, D. E., "Optimal Estimation: an Introduction to the Theory and Applications", NPS, Monterey, CA, 1975.
14. Kirk, D. E., Optimal Control Theory an Introduction, Prentice-Hall, 1970.
15. Luenberger, D. G., "An Introduction to Observer", IEEE Trans. Autom. Control, Vol. AC-16, No. 6, pp. 596-602, 1971.
16. Luenberger, D. G., "Observers for Multivariable Systems", IEEE Transactions on Automatic Control, Vol. AC-11, pp. 190-197, April 1966.
17. Ferguson, J. D. and Rekasious, Z. V., "Optimal Linear Control Systems with Incomplete State Measurements", IEEE Transactions on Automatic Control, Vol. AC-14, No. 2, April 1969.
18. Aoki, M., "Control of Large Scale Dynamic Systems by Aggregation", IEEE Trans. Automatic Control, Vol. AC-13, No. 3, pp. 246-253, June 1968.
19. Tyler, J. S. and Tuteur, F. B., "The Use of a Quadratic Performance Index to Design Multivariable Control Systems", IEEE Trans. Aut. Control, Vol. AC-11, No. 1, pp. 84-91, Jan 1966.
20. Weaver, L. E., "Reactor Dynamics and Control", Am Elsevier, New York, 1968.
21. Sinha, N. K. and Bereznai, G. T., "Suboptimal Control of Nuclear Reactors Using Low Order Models", Int. J. Control, Vol. 18, No. 2, pp. 305-319, 1973.
22. Rice, J. R., The Approximation of Functions, Addison-Wesley, Vol. 1, 1964.

INITIAL DISTRIBUTION LIST

	No. Copies
1. Defense Technical Information Center Cameron Station Alexandria, Virginia 22314	2
2. Library, Code 0142 Naval Postgraduate School Monterey, California 93940	2
3. Department Chairman, Code 62 Department of Electrical Engineering Naval Postgraduate School Monterey, California 93940	2
4. Professor D. E. Kirk, Code 62Ki Department of Electrical Engineering Naval Postgraduate School Monterey, California 93940	1
5. Professor J. M. Goldman, Code 62Go Department of Electrical Engineering Naval Postgraduate School Monterey, California 93940	5
6. Professor Alex Gerba, Jr., Code 62Gz Department of Electrical Engineering Naval Postgraduate School Monterey, California 93940	1
7. Professor George J. Thaler, Code 62Tn Department of Electrical Engineering Naval Postgraduate School Monterey, California 93940	1
8. Professor Robert D. Strum, Code 62St Department of Electrical Engineering Naval Postgraduate School Monterey, California 93940	1
9. Professor Harold A. Titus, Code 62Ts Department of Electrical Engineering Naval Postgraduate School Monterey, California 93940	1
10. Admiral Gilberto Barona Comandante Armada Nacional Centro Administrativo Nacional (CAN) Bogota D.E. Colombia S.A.	1

11. Vice-Admiral Benjamin Alzate 1
Segundo Comandante Armada Nacional
Centro Administrativo Nacional (CAN)
Bogota D.E.
Colombia S.A.
12. Vice-Admiral Hector Calderon 1
Subjefe Estado Mayor Conjunto
Ministerio de Defensa Nacional
Centro Administrativo Nacional (CAN)
Bogota D.E.
Colombia S.A.
13. Vice-Admiral Guillermo Uribe 1
Inspector General Comando Armada
Centro Administrativo Nacional (CAN)
Bogota D.E.
Colombia S.A.
14. Rear-Admiral Rafael Martinez 1
Director Escuela Naval de Cadetes
Cartagena
Colombia S.A.
15. Teniente de Navio William Porras 4
Pie de la Popa Kra 19A #29-C41
Edificio La Ermita 3er Piso
Cartagena
Colombia S.A.

Thesis
P7417 Porras
c.1

190977

Reduced order models
via continued fractions
applied to control sys-
tems.

Thesis
P7417 Porras
c.1

190977

Reduced order models
via continued fractions
applied to control sys-
tems.

thesP7417

Reduced order models via continued fract

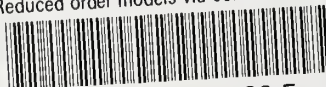

3 2768 000 99289 5

DUDLEY KNOX LIBRARY