



Calhoun: The NPS Institutional Archive
DSpace Repository

Theses and Dissertations

1. Thesis and Dissertation Collection, all items

2014-06

Power systems and energy storage modeling for directed energy weapons

Sylvester, Jeremy E.

Monterey, California: Naval Postgraduate School

<https://hdl.handle.net/10945/42734>

This publication is a work of the U.S. Government as defined in Title 17, United States Code, Section 101. Copyright protection is not available for this work in the United States.

Downloaded from NPS Archive: Calhoun



Calhoun is the Naval Postgraduate School's public access digital repository for research materials and institutional publications created by the NPS community. Calhoun is named for Professor of Mathematics Guy K. Calhoun, NPS's first appointed -- and published -- scholarly author.

Dudley Knox Library / Naval Postgraduate School
411 Dyer Road / 1 University Circle
Monterey, California USA 93943

<http://www.nps.edu/library>



**NAVAL
POSTGRADUATE
SCHOOL**

MONTEREY, CALIFORNIA

THESIS

**POWER SYSTEMS AND ENERGY STORAGE
MODELING FOR DIRECTED ENERGY WEAPONS**

by

Jeremy E. Sylvester

June 2014

Thesis Co-Advisors:

Joseph A. Blau

William B. Colson

Second Reader:

Keith R. Cohn

Approved for public release; distribution is unlimited

THIS PAGE INTENTIONALLY LEFT BLANK

REPORT DOCUMENTATION PAGE			<i>Form Approved OMB No. 0704-0188</i>
Public reporting burden for this collection of information is estimated to average 1 hour per response, including the time for reviewing instruction, searching existing data sources, gathering and maintaining the data needed, and completing and reviewing the collection of information. Send comments regarding this burden estimate or any other aspect of this collection of information, including suggestions for reducing this burden, to Washington headquarters Services, Directorate for Information Operations and Reports, 1215 Jefferson Davis Highway, Suite 1204, Arlington, VA 22202-4302, and to the Office of Management and Budget, Paperwork Reduction Project (0704-0188) Washington, DC 20503.			
1. AGENCY USE ONLY (Leave blank)	2. REPORT DATE June 2014	3. REPORT TYPE AND DATES COVERED Master's Thesis	
4. TITLE AND SUBTITLE POWER SYSTEMS AND ENERGY STORAGE MODELING FOR DIRECTED ENERGY WEAPONS		5. FUNDING NUMBERS	
6. AUTHOR(S) Jeremy E. Sylvester			
7. PERFORMING ORGANIZATION NAME(S) AND ADDRESS(ES) Naval Postgraduate School Monterey, CA 93943-5000		8. PERFORMING ORGANIZATION REPORT NUMBER	
9. SPONSORING /MONITORING AGENCY NAME(S) AND ADDRESS(ES) N/A		10. SPONSORING/MONITORING AGENCY REPORT NUMBER	
11. SUPPLEMENTARY NOTES The views expressed in this thesis are those of the author and do not reflect the official policy or position of the Department of Defense or the U.S. Government. IRB Protocol number ____N/A____.			
12a. DISTRIBUTION / AVAILABILITY STATEMENT Approved for public release; distribution is unlimited		12b. DISTRIBUTION CODE A	
13. ABSTRACT (maximum 200 words) As the United States Navy makes leaps forward in technology that is being deployed onboard ships, there is a growing need for research to predict what will be needed to integrate new weapon systems with old. Directed energy weapons are being deployed onboard naval platforms starting in 2014, and this paper seeks to answer the question of what energy storage, if any, must be used in conjunction with high-power lasers in order to integrate them with current ships in the fleet. Four energy storage methods are being researched. These storage medias will allow a ship to fire multiple shots from a high-powered laser without taxing the ship's electrical system. Lead acid batteries, lithium ion batteries, supercapacitors, and flywheels each have their benefits and drawbacks, and those will be discussed. A computer simulation has been developed and used to represent a DDG-51 Arleigh Burke class destroyer and each of the four energy storage methods. This simulation was run repeatedly with different powered high-powered lasers in order to produce a recommendation for what types of energy storage would be necessary to operate these devices onboard ships.			
14. SUBJECT TERMS Energy storage, flywheel, battery, directed energy weapons, laser systems, power systems		15. NUMBER OF PAGES 65	16. PRICE CODE
17. SECURITY CLASSIFICATION OF REPORT Unclassified	18. SECURITY CLASSIFICATION OF THIS PAGE Unclassified	19. SECURITY CLASSIFICATION OF ABSTRACT Unclassified	20. LIMITATION OF ABSTRACT UU

THIS PAGE INTENTIONALLY LEFT BLANK

Approved for public release; distribution is unlimited

**POWER SYSTEMS AND ENERGY STORAGE MODELING FOR DIRECTED
ENERGY WEAPONS**

Jeremy E. Sylvester
Lieutenant, United States Navy
B.S., Oregon State University, 2005

Submitted in partial fulfillment of the
requirements for the degree of

MASTER OF SCIENCE IN PHYSICS

from the

**NAVAL POSTGRADUATE SCHOOL
June 2014**

Author: Jeremy E. Sylvester

Approved by: William B. Colson
Thesis Co-Advisor

Joseph A. Blau
Co-Advisor

Keith R. Cohn
Second Reader

Andres Larraza
Chair, Department of Physics

THIS PAGE INTENTIONALLY LEFT BLANK

ABSTRACT

As the United States Navy makes leaps forward in technology that is being deployed onboard ships, there is a growing need for research to predict what will be needed to integrate new weapon systems with old. Directed energy weapons are being deployed onboard naval platforms starting in 2014, and this paper seeks to answer the question of what energy storage, if any, must be used in conjunction with high-power lasers in order to integrate them with current ships in the fleet.

Four energy storage methods are being researched. These storage medias will allow a ship to fire multiple shots from a high-powered laser without taxing the ship's electrical system. Lead acid batteries, lithium ion batteries, supercapacitors, and flywheels each have their benefits and drawbacks, and those will be discussed. A computer simulation has been developed and used to represent a DDG-51 Arleigh Burke class destroyer and each of the four energy storage methods. This simulation was run repeatedly with different powered high-powered lasers in order to produce a recommendation for what types of energy storage would be necessary to operate these devices onboard ships.

THIS PAGE INTENTIONALLY LEFT BLANK

TABLE OF CONTENTS

I.	INTRODUCTION.....	1
II.	DIRECTED ENERGY OVERVIEW	3
III.	ENERGY STORAGE	7
IV.	SIMULATION METHODS.....	15
V.	ANALYSIS AND RESULTS.....	23
A.	LEAD ACID ENERGY STORAGE RESULTS	23
B.	LITHIUM ION ENERGY STORAGE RESULTS	26
C.	FLYWHEEL ENERGY STORAGE DESIGN AND RESULTS.....	29
1.	Flywheel Design.....	29
2.	Flywheel Energy Storage Results	31
a.	125 kW Laser Simulations.....	32
b.	60 kW Laser Simulations.....	33
c.	30 kW Laser Simulations.....	34
D.	RESULTS WITH THE FULL MODEL OF THE SHIP	36
E.	TRANSIENTS AND INSTABILITIES	40
VI.	CONCLUSIONS.....	43
	LIST OF REFERENCES.....	47
	INITIAL DISTRIBUTION LIST	49

THIS PAGE INTENTIONALLY LEFT BLANK

LIST OF FIGURES

Figure 1.	Energy densities of various battery chemistries and configurations. ...	10
Figure 2.	Energy density versus power density for different energy storage media.....	13
Figure 3.	Simple RC circuit constructed in Simulink.	15
Figure 4.	Voltage (V) per time (s) across the capacitor in Figure 3.....	16
Figure 5.	Simulink model overview of an entire ship's system.....	17
Figure 6.	Model of a lead acid battery in Simulink. The individual components can be modified to replicate the characteristics of most batteries.	18
Figure 7.	The lead acid parameter box allows for changes to be made to the number of cells and their configuration.....	19
Figure 8.	Adjustable pulse structure of the laser output in Simulink	21
Figure 9.	State of charge versus time over four pulses for a 125 kW laser with a 3 second pulse, 50% duty cycle, with one string of 100 lead-acid batteries. The red line represents a linear fit to the blue SOC data.	24
Figure 10.	The number of 125 kW laser pulses (shots) until depletion for different duty cycles and pulse lengths, for 1, 2, or 3 strings of 100 lead-acid batteries.	25
Figure 11.	The number of 60 kW laser pulses (shots) until depletion for different duty cycles and pulse lengths, for 1, 2, or 3 strings of 100 lead-acid batteries.	25
Figure 12.	The number of 30 kW laser pulses (shots) until depletion for different duty cycles and pulse lengths, for 1, 2, or 3 strings of 100 lead-acid batteries.	26
Figure 13.	The number of 6-second shots available until 20% state of charge is reached, for various numbers of Li-ion battery strings. A 50% duty cycle was used in each case. The 60 kW laser exceeded 200 shots in the 2, 3, and 4 string cases.	28
Figure 14.	The number of 6-second shots available until 20% state of charge is reached, for various numbers of Li-ion battery strings. The 60 kW laser exceeded 200 shots in the 2, 3, and 4 string cases. A 50% duty cycle was used in each case.	28
Figure 15.	Number of 6-second shots each flywheel design could supply to a 125 kW laser at different rotational speeds.	33
Figure 16.	Number of 6-second shots each flywheel design could supply to a 60 kW laser at different rotational speeds.	34
Figure 17.	Number of 6-second shots each flywheel design could supply to a 30 kW laser at different rotational speeds.	35
Figure 18.	DC bus voltage over time for a 125 kW laser and 1 string of lead acid batteries. At 1s a laser pulse turns on. At 7s the laser pulse turns off and the begins to battery recharge. Initial spikes are due to	

	instabilities the model experiences when all of the ship's systems are initially turned "on."	37
Figure 19.	Current output from the ship to the lead acid battery as a function of time. A laser pulse was initiated at 1s and ended at 7s, when current spiked to begin recharging the batteries. Initial spikes are due to instabilities the model experiences when all of the ship's systems are initially turned "on"	38
Figure 20.	Typical discharge and recharge curve for a flywheel's speed in RPM (FWRPM) for the energy storage model used for simulations, for a 6 second, 125 kW laser pulse beginning at t=1s.	40
Figure 21.	The power output of the laser. Each pulse is a firing of the laser.	41
Figure 22.	Power output from a laser after adjustment to the capacitance in the power converter leading to the laser.....	41
Figure 23.	Current to a lead acid battery while recharging. The 0.003 millisecond period correlate to a 360 Hz oscillation.....	42

LIST OF TABLES

Table 1.	Various Flywheel designs tested for the 125 kW laser.	32
Table 2.	Various flywheel designs tested for the 60 kW laser.	33
Table 3.	Various flywheel designs for the 30 kW laser.	35
Table 4.	Resulting changes in ship's key electrical parameters during the recharge cycle of the lead acid and lithium ion batteries. For the 30 kW laser with no energy storage the maximum DC bus voltage Drop was due to the laser pulse, since there is no energy storage. ...	39
Table 5.	Weight and volume requirements for the suggested configurations of energy magazines for various laser power levels. These are the minimum configurations required to deliver approximately sixty 6-second shots at a 50% duty cycle. Of note, the flywheel volume and weight is for the rotor only; the casing and motor generator will add to this.	44

THIS PAGE INTENTIONALLY LEFT BLANK

LIST OF ACRONYMS AND ABBREVIATIONS

CIWS	Close-in Weapon System
DEW	Directed Energy Weapon
EMALS	Electromagnetic Aircraft Launch System
FEL	Free electron laser
kW	Kilo-watt
LCS	Littoral Combat Ship
LAWS	Laser Weapon System
MLD	Maritime Laser Demonstration
MW	Mega-watt
NiMH	Nickel metal hydride
RPM	Revolutions per minute
SOC	State of charge
SSL	Solid-state laser
UT-CEM	University of Texas Center for Electro Mechanics
YAG	Yttrium aluminum garnet

THIS PAGE INTENTIONALLY LEFT BLANK

I. INTRODUCTION

In a world of constantly evolving combat science, the United States Navy has stayed ahead of other nations in innovation and technology. There is constant research and development involved in discovering the next “game changer” that keeps our military comfortably able to confront any challenge. Directed energy weapons have been researched for decades but are now making their way onto naval platforms. These systems will allow our naval combatants the ability to target multiple adversaries at significant ranges and to deliver energy at the speed of light to relevant targets. A 30 kW solid-state laser is now being installed for deployment onboard the USS Ponce in FY 2014.¹ As lasers progress in technology and power, the question remains: are the power systems on our ships ready for these innovations, and, if not, what is necessary to make them ready?

Future all-electric ships may generate enough power that additional energy considerations are not necessary but older ships may need to be back fitted with these weapons as well. The Arleigh Burke class destroyer, DDG-51, was the first class of ship to have a laser (temporarily) installed.¹ If the ship’s power generation system is unable to directly power the laser, then energy storage methods must be considered. These “energy magazines” would provide the necessary power for multiple engagements, and then be recharged during downtime. Four types of energy storage methods will be discussed: lead acid batteries, lithium ion batteries, supercapacitors, and flywheels.

This thesis investigates three different laser powers that are likely to be employed within the next decade and to compare the results of using these lasers with three different types of energy magazines. The program Simulink by Mathworks will be used to simulate the electrical system of the DDG-51 warship

¹ Office of Naval Research. "Navy Leaders Announce Plans for Deploying Cost-Saving Laser Technology." Accessed April 20, 2014.
http://www.navy.mil/submit/display.asp?story_id=73234.

with each energy storage method. Based upon the results of these simulations, a recommendation will be given for the design of each type of magazine.

II. DIRECTED ENERGY OVERVIEW

Legend places the first “speed of light” weapon at 212 BC in Syracuse, when the fabled Archimedes supposedly used mirrors to reflect sunlight onto the invading ships of the Romans with hopes of destroying them before they could invade.² Numerous attempts have failed to prove the effectiveness of this ancient method of attack but the idea of light as a weapon persists today. High-powered Solid State Lasers (SSLs) and Free Electron Lasers (FELs) offer the potential of destroying or disabling threats such as missiles, planes, and small craft at ranges on the order of several kilometers.

For many decades military services have worked to make a viable laser weapon. Among the many issues facing laser weapons include scaling them to a high enough power to be useful without making their physical presence so large they become impractical as weapon systems. Recently, the combining of multiple beams from either fiber or slab-type SSLs have made them powerful enough at moderate sizes to be near-term candidates for deployment; multi-kilowatt class SSL is planned to be deployed on current ships in the fleet and incorporated into the design of new destroyers arriving within the next decade. However, scaling SSLs to MW class is thought to be impractical, so research continues to scale FELs to the MW level. Size does not scale dramatically upward with power, unlike for the SSL.

There are several advantages to a speed-of-light weapon. Unlike a kinetic weapon, energy is delivered almost instantaneously to a target. An all-electric laser weapon does not carry physical ordinance so there is no need to store ammunition and it continues to operate so long as it is supplied with adequate power; the equivalent of ammunition is stored as ship’s fuel. The result is a cost-

² Massachusetts Institute of Technology. "Archimedes Death Ray: Idea Feasibility Testing." Accessed March 14, 2014. http://web.mit.edu/2.009/www/experiments/deathray/10_ArchimedesResult.html.

per-shot as low as a few dollars, or less than a gallon's worth of fuel.³ This makes the high-energy laser much more cost effective than current countermeasures onboard the ship.

Other advantages include defeating evasive maneuvers of incoming weapons or craft. Traditional methods are the Sea Sparrow or Close-in Weapon System (CIWS) to protect the ship from an airborne threat but both must react to the maneuvers of the target. A laser has been shown to be able to easily focus on incoming missiles and can rapidly adjust to a maneuvering target with minute changes in the pointing direction of the mirror. The Laser Weapon System (LAWS) tested onboard the USS Dewey successfully shot down several drones in 2012, proving that lasers on ships could track and destroy airborne targets at sea.⁴

Despite all their advantages, various issues have prevented lasers from being incorporated onto ships up to now. A major issue is scaling the laser to high enough powers to be effective for the desired missions given limitations of cost, available space and technology. For the SSLs being considered, cooling requirements are also significant. If an SSL is 25% efficient, then for every kilowatt of energy leaving the weapon there are 3 kW worth of heat to be removed from the system. Scaled to hundreds of kilowatts this results in massive new loads on the ship's cooling system.

Another issue is getting the laser energy to the target. Optical elements are very sensitive to defects and foreign material and must be kept meticulously clean. In addition, the laser power meant to destroy targets must not damage the optics at the source. This may require special materials and cooling requirements. Furthermore, as a high-power laser beam passes through the

³ Phil Stewart. "U.S. Navy to Field First Laser Weapon, could Shoot Down a Drone." *Reuters*, April 8, 2013, accessed April 3, 2014, <http://www.reuters.com/article/2013/04/08/us-usa-weapons-laser-idUSBRE93716Z20130408>.

⁴ Spencer Acherman. "Watch the Navy's New Ship Mounted Laser Cannon Kill a Drone." Accessed April 3, 2014. http://www.wired.com/2013/04/laser-warfare-system/?utm_source=rss&utm_medium=rss&utm_campaign=watch-navys-new-laser-cannon-mounted-on-a-ship-kill-a-drone.

atmosphere, it can heat the air, causing a change in the index of refraction that results in distortion and deflection of the beam; this effect is known as “thermal blooming.”⁵ Other negative atmospheric effects include turbulence, absorption, and scattering, even at low power.

There are currently two types of SSLs being considered for shipboard use, slab and fiber lasers. A slab laser consists of a large block of lasing material such as neodymium or ytterbium doped yttrium aluminum garnet (YAG) crystal.⁶ The Maritime Laser Demonstration (MLD) features several 15 kW slab lasers combined together to produce a 105 kW laser. The seven slabs required for 105 kW occupies ~50 cubic feet of volume, not including support systems.⁷ The second type of laser is the fiber laser. This is the type tested onboard the USS Dewey and the type that will be deployed onboard the USS Ponce in 2014. The laser substrate is similar to a fiber optic cable that is doped with a rare earth element (typically neodymium or ytterbium); many fibers can be combined to produce a larger output power.⁸ The combination of multiple fibers theoretically allows for scaling up to over 100 kW. The LAWS features the combination of six 5.5 kW welding lasers to produce a 33 kW output.⁹ The benefit to this prototype is that it utilizes existing off-the-shelf technology.

⁵ P. Sprangle, J. R. Peñano and A. Ting. "Propagation of High-Energy Lasers in a Maritime Atmosphere." *Naval Research Laboratory*, 2014, accessed April 5, 2014, <http://www.nrl.navy.mil/research/nrl-review/2004/featured-research/sprangle/>.

⁶ John Kuseian. *Naval Power Systems Technology Development Roadmap PMS 430*. (Washington DC: Electric Ships Office PMS 320, 2013).

⁷ Ibid.

⁸ Ibid.

⁹ Ibid.

THIS PAGE INTENTIONALLY LEFT BLANK

III. ENERGY STORAGE

Few power systems onboard ships can support sustained usage of a high-powered laser without additional energy storage. The new DDG-1000 may have enough electrical energy, but other platforms such as the Freedom and Independence class LCS's may require some type of "energy magazine." This magazine stores energy for on-demand usage by the laser. It can be made up of batteries, capacitors, or flywheels, and would recharge between laser pulses. The energy magazine should allow for sustained usage against a swarm of targets in an engagement lasting up to twenty minutes. Ideally, it would charge up as fast as it discharges, allowing for indefinite use (as long as there is ship's fuel to expend). Low maintenance, high safety, and long lifespan are other desirable characteristics.

Typical lead-acid batteries have changed little in the last hundred years. They are readily available and come in many varieties and sizes but share similar construction. Two metal plates, one lead and one lead-oxide, are immersed in a sulfuric acid solution. This creates one cell, which typically produces 2.1 volts.¹⁰ These cells may be combined in series to give an overall voltage equal to the sum of the individual cell voltages. For example, in a typical car battery, six cells are combined to produce ~12.6 volts. The following equations are the half reactions and overall reaction for the lead acid battery¹¹:

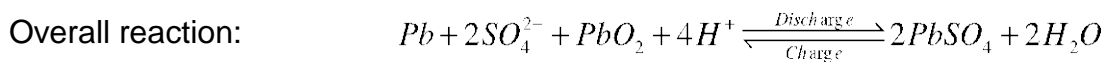
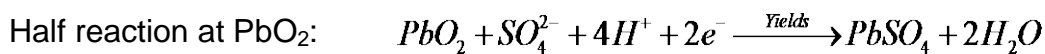

¹⁰ Detchko Pavlov, *Lead-Acid Batteries - Science and Technology - A Handbook of Lead-Acid Battery Technology and Its Influence on the Product* (Amsterdam: Elsevier, 2011).

¹¹ Ibid.

Once the two plates are electrically connected the discharge reaction begins. The reaction at the lead plate causes lead to be oxidized to form lead-sulfate, which coats the plate. This process releases hydrogen ions and electrons. At the lead-oxide plate, the lead oxide is reduced (gains electrons) and also produces a lead sulfate coating on the plate, plus water. The overall effect is the flow of electrons from the lead plate to the lead oxide plate and the production of lead-sulfate on the surface of both plates, as seen in the reaction above. During the recharge cycle the voltage is reversed and the reaction is forced into the opposite direction.

Lithium ion batteries work similar to lead acid, but with different elements. A typical construction consists of a sheet of Lithium-cobalt-oxide and a sheet of carbon separated by an insulator. These sheets can be rolled and immersed in an electrolyte, allowing for the passage of charges between the cathode (Lithium) sheet and the anode (carbon) sheet. The layers of lithium and carbon constitutes a cell that has a potential charge of 3.7 volts,¹² making them more compact than the lead acid cell that stores only 2.1 volts. During the charging process, a voltage is applied across the sheets and lithium ions move from the cathode to anode, where the lithium ions attach to the carbon. During discharge, lithium ions return to the cathode.¹³

Nickel Metal Hydride batteries have been in use for years and see widespread use in millions of hybrid cars. NiMH batteries use a nickel-hydroxide cathode and hydrogen absorbing alloys as an anode. Potassium hydroxide is the common electrolyte used. NiMH batteries do not have the capacities of the lithium ion batteries that have largely replaced them in consumer electronics. In

¹² Battery University. "Advantages and Limitations of the Lithium-Ion Battery." Accessed April 5, 2014. http://batteryuniversity.com/learn/article/is_lithium_ion_the_ideal_battery.

¹³ Walter van Schalkwijk and Bruno Scrosati, *Advances in Lithium-Ion Batteries*. (Hingham: Kluwer, 2002).

addition, self-discharge rates are high. Overall, NiMH is a safer choice than lithium batteries but do not offer the same storage capacity.¹⁴

Advantages and disadvantages are similar for all batteries. Batteries have high energy density and specific energy. They maintain their charge for many hours or even days in a stable, readily available form. The construction of individual cells allows for modular design, making their additions, subtractions, and replacements onboard ships simple. Many different designs and manufacturers are available for all types of batteries. Lithium based batteries continue to advance in design due to their extensive use in consumer products.¹⁵

Batteries have some drawbacks. Their discharge rate is limited and they produce large amounts of heat during heavy use, which may affect their performance. Their charge rates are much slower than their discharge rates. A given amount of energy taken out of the battery in 15 minutes can take hours to put back in. Over time, less than ideal charge and discharge rates and depth of discharge can lead to a loss of capacity. With many lead acid batteries off-gassing is possible during the charge process. This is the production of hydrogen due to the chemical reaction taking place between the lead and the hydrogen sulfate. With lithium ion batteries, which contain materials that are highly reactive, any damage between the cathode and anode can result in a short that may cause a fire. Finally, batteries are temperature sensitive and must be properly maintained.¹⁶

Future trends in battery technology include improved safety for lithium batteries, improved service life, and lower overall ownership. Due to civilian interest in battery technology, off-the-shelf products are available with little military investment. Research is being performed to increase recharge rate, though it is still an order of magnitude lower than discharge rates. Battery

¹⁴ *Wikipedia*. "Nickel-Metal Hydride Battery." Accessed May 10, 2014. http://en.wikipedia.org/wiki/Nickel-metal_hydride_battery.

¹⁵ *Ibid*.

¹⁶ *Ibid*.

management systems and thermal controls are also being added as standard to high-end models. Figure 1 illustrates the relationship between specific energy (Watt-hours/kg) and energy density (Watt-hours/liter) for different batteries. Lithium batteries provide much higher power storage per kilogram or liter than lead-acid batteries.¹⁷

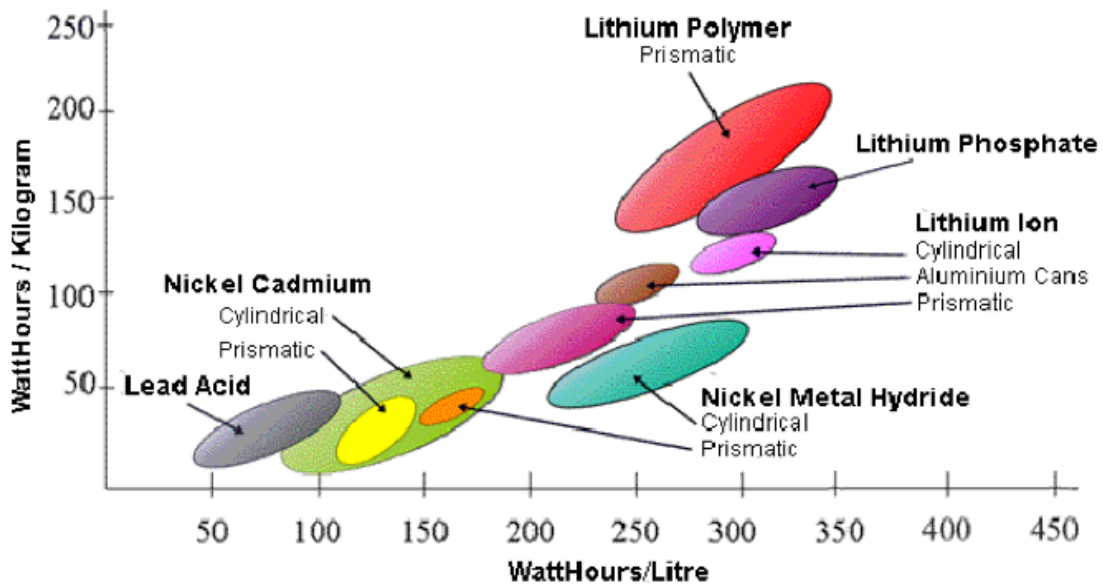

Figure 1. Energy densities of various battery chemistries and configurations.¹⁸

Capacitors are a mature technology that has risen as a competitive energy storage option with the development of supercapacitors. Conventional capacitors consist of two conducting plates separated by a dielectric insulator. Charge separation causes a potential difference. When separated by a dry insulator these plates typically hold a capacitance of picofarads up to a few microfarads.

¹⁷ John Kuseian. *Naval Power Systems Technology Development Roadmap PMS 430*. (Washington DC: Electric Ships Office PMS 320, 2013).

¹⁸ Ibid.

When a moist separator or electrolyte is used, many microfarads are achievable.¹⁹

The latest advance in capacitor technology is the supercapacitor. In a supercapacitor, a carbon electrode coated with a porous material (usually activated charcoal) is inserted into an electrolytic solution. The walls of the pores provide the charge surfaces for the storing charge and the electrolyte connects them in series. The discharge rate for the supercapacitor is slower than for a regular capacitor, a trade-off for higher energy storage. Supercapacitors are still limited to ~2.7 volts and a specific energy density of 30Wh/kg. This is one fifth of that for a lithium ion battery. The voltage limitation can be overcome by adding cells in series.²⁰

Advantages of capacitors include a very high cycle life and charge rates that nearly match discharge rates. Also, super capacitors can be “floated” for long lengths of time. This means that they will hold their charge (potential energy) for a long period without a large residual decay. Shelf life is comparable to batteries and depends upon the type and design of the capacitor.²¹

Due to their high discharge rates, there are innate safety issues with capacitors. A short can lead to very high currents that can spark fires, electrocutions, or damage to electronics. When combined in series, careful voltage control is required to operate several capacitors properly, leading to a more complex system. Trends in capacitors center around improving the lifetime and providing a higher energy density. Also, work is being done to improve the safety and reduce self-discharge rates. Important to lasers is the ability to scale supercapacitors to higher voltage arrays, as a single cell typically only provides a few volts.²²

¹⁹ Marshal Brain and Charles Bryant. "How Capacitors Work." Accessed May 10, 2014, <http://electronics.howstuffworks.com/capacitor.htm>.

²⁰ Jesus La Fuente. "Graphene Supercapacitors - what are they?" Accessed May 15, 2014. <http://www.graphenea.com/pages/graphene-supercapacitors#.U5JXhF5sApE>.

²¹ Ibid.

²² Ibid.

Flywheels are an old technology being used in a new way. Storing energy in the form of inertia avoids many of the disadvantages of batteries and capacitors. The technology is relatively simple. Flywheels use motor-generators attached to spinning discs and convert mechanical energy to electrical energy and back again at >95% efficiency.²³ Increasing either the rotational speed or the mass of a flywheel allows it to store more energy. There is a limit to the tip-speed (the linear speed at the outer radius of the wheel) of the flywheel so that material stresses must be balanced by coordinating geometry with dynamics. Newer developments involve using enclosures that allow the flywheel to operate in a vacuum and utilize magnetic bearings over traditional mechanical bearings. This allows a low-drag, low-friction operation that improves efficiency. Also, combination of the motor-generator rotor and flywheel into one unit saves on weight and space. The new Ford class of carriers is planned to use flywheels in its EMALS (Electromagnetic Aircraft Launch System) system.²⁴

Flywheels have a very high efficiency during cyclic operation. With magnetic bearings there are no wear parts that require replacement. Unlike batteries and capacitors, there are no chemicals or gassing issues. One of the largest advantages is that the flywheel can be charged almost as quickly as it can be discharged at the power levels required by high-energy lasers.²⁵

With any high energy density system designed to deliver energy quickly there are safety concerns. With high speed spinning discs onboard a dynamic platform like a warship there are concerns should the device ever mechanically fail. In addition, the more advanced flywheels require complex support systems to cool and protect them, as well as to hold a vacuum inside the enclosure.

²³ Ibid.

²⁴ Energy Storage Association. "Flywheels." Accessed May 15, 2014. <http://energystorage.org/energy-storage/technologies/flywheels>.

²⁵ Ibid.

Trends include better safety containments, higher charge/discharge rates with better efficiency, and improved service life.²⁶

Figure 2 summarizes energy density vs. power density for different energy storage methods. The vertical axis represents how much energy can be stored per weight. The horizontal axis represents how quickly the energy can be released, per kilogram. Capacitors traditionally have a very low capacity to hold energy but release it very quickly, similar to a spark. Batteries are very high in energy density, but much slower when releasing that energy. Flywheels and supercapacitors fall in between. Matching the needs of the load to the graph assists in determining the type of energy storage needed for a particular application.

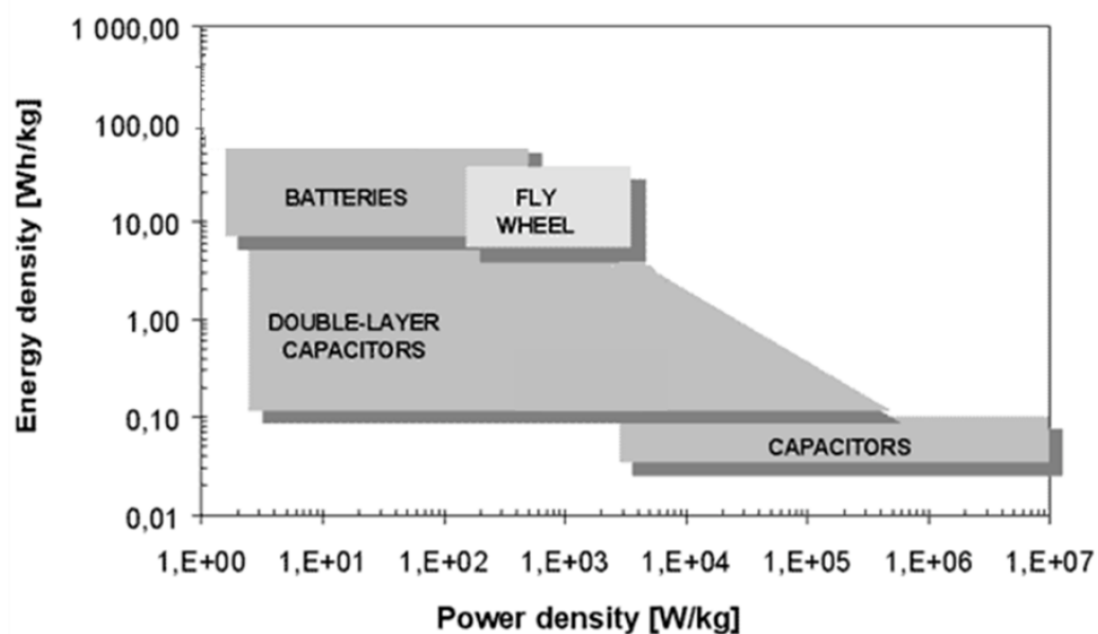

Figure 2. Energy density versus power density for different energy storage media.²⁷

²⁶ John Kuseian. *Naval Power Systems Technology Development Roadmap PMS 430*. (Washington DC: Electric Ships Office PMS 320, 2013).

²⁷ Ibid.

THIS PAGE INTENTIONALLY LEFT BLANK

IV. SIMULATION METHODS

The program Simulink by MathWorks is commonly used in industry, government, and academia for modeling complex systems, such as biological processes, spaceflight, and power systems. Individual blocks are used to represent processes that occur in electrical or mechanical components, and these blocks are connected with lines that may represent electrical connections. The accuracy of the model depends on the accuracy to which the blocks represent an actual system, including any numerical errors that are introduced by the solver. Part of the task of simulating systems is to reduce or separate numerical artifacts from the physical processes.

The following example developed with Simulink shows a simple RC circuit and the resulting output:

$$V_s = 100 \text{ V}; R = 1000 \ \Omega; C = 400 \text{ mF}$$

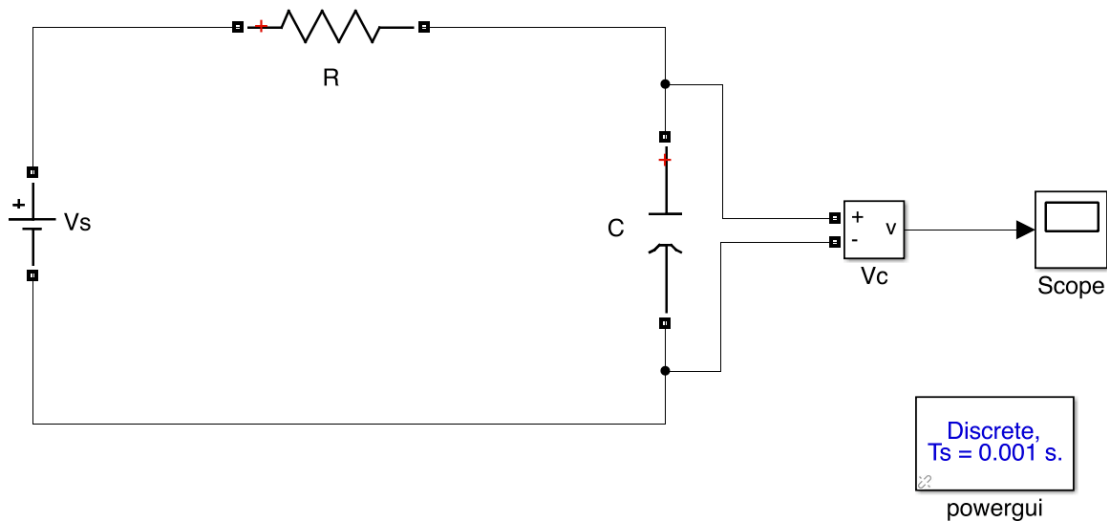

Figure 3. Simple RC circuit constructed in Simulink.

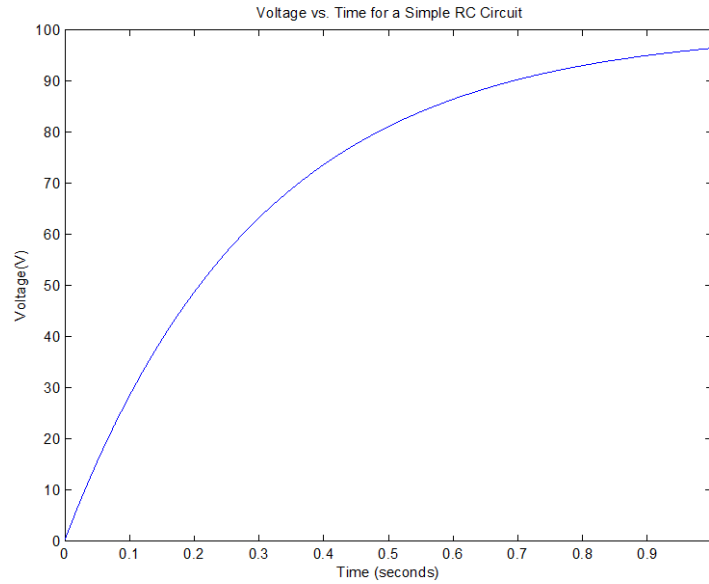

Figure 4. Voltage (V) per time (s) across the capacitor in Figure 3.

As expected, there is a rise in voltage across the capacitor, exponentially approaching the battery potential of 100 Volts. The $1/e$ rise time agrees with the time constant $\tau = RC$ expected of an RC circuit. Adding blocks that represent sources, loads, electrical components, and losses can produce the model of an entire system or even an entire ship. The following is a Simulink[®] model diagram of the DDG-51 Arleigh Burke-class destroyer, including a solid-state laser, power conversion, and energy storage, produced by the Center for Electromechanics of the University of Texas at Austin for the Naval Postgraduate School.

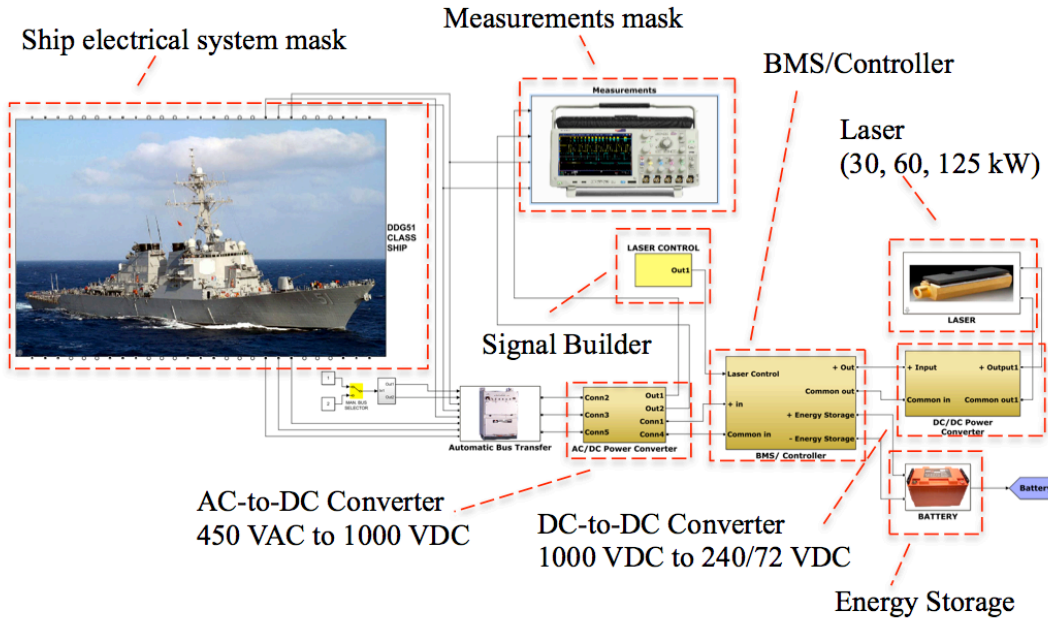

Figure 5. Simulink model overview of an entire ship's system.

Each of the blocks in Figure 5 (called “masks”) represents a whole system. These blocks are based on actual designs for the various components. For example, the ship’s mask is based upon the ship’s electrical schematics. They are combined with models for energy storage and a laser to produce an overall model used for simulations. A more detailed analysis for each block can be found in reference 4. Due to the modular nature of Simulink it is possible to simply remove one ship model and replace it with another. Four classes of ships are planned to be modeled, the DDG-51, DDG-1000, and both the Independence class and Freedom class of the littoral combat ship. This thesis focuses on the DDG-51.

Four energy storage methods are also modeled: the lithium-ion battery, lead-acid battery, supercapacitor, and flywheel. These four modules can be interchanged with the ship model to simulate different options. Figure 6 shows the details inside the mask of the lead-acid battery system.

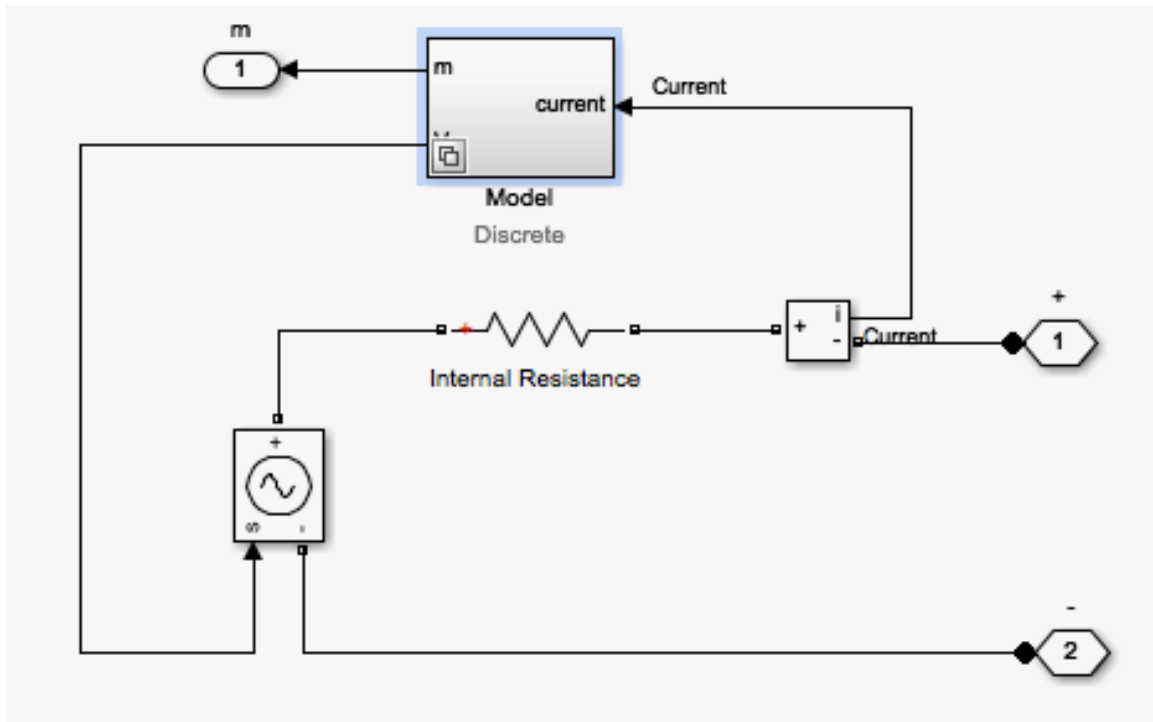

Figure 6. Model of a lead acid battery in Simulink. The individual components can be modified to replicate the characteristics of most batteries.

Within Figure 6 are yet more blocks that can be adjusted as needed to model different brands and types of batteries. Each numbered box is a connection to other parts of the system. The internal resistance is that of the battery. The discrete model can be opened to expose the logic blocks that describe the behavior of the battery.

Block Parameters: Lead Acid Battery Storage

Lead Acid Battery Model (mask)

General model of a lead acid battery.
Enter all parameters, even if only estimated, for one battery unit.
The last two inputs describe the make-up of the whole battery system.

Parameters

Nominal Voltage, V
12

Rated Capacity, Ah
68

Initial State of Charge, %
100

Maximum Capacity, Ah
72

Fully Charged Voltage, V
13.28

Nominal Discharge Current, A
6.5

Internal Resistance, Ohms
0.0035

Capacity at Nominal Voltage, Ah
64

Voltage at end of initial exp. drop, V
12.8

Capacity at end of initial exp. drop, Ah
6

Number of batteries in series in a string
100

Number of battery strings in parallel
1

OK Cancel Help Apply

Figure 7. The lead acid parameter box allows for changes to be made to the number of cells and their configuration.

These models have been designed to be very flexible. Figure 7 shows how the lead-acid battery allows the user to adjust battery voltages, number of cells in series (a “string” of batteries), and number of strings in parallel, and is designed using batteries available on the market today. This allows for many optimization runs based on different laser scenarios. It will be shown that one

string of one hundred cells will not be sufficient to supply a 125kW laser for more than a few shots. An accurate model allows for optimizing the number of cells and the type of battery that would best suit directed energy weapon (DEW) technology. The lead-acid battery is based on the Genesis XE70 battery by EnerSys. The lithium-ion battery model is similar to the lead-acid model and is based on the VL-30 PFe cell by Saft America. Output parameters of the battery that can be measured include the voltage, current, power, and state of charge (% charged) of the batteries.

The capacitor model is based on the BMOD0063 P125 by Maxwell Technologies. Like the battery model, the voltage, number of cells in a series string, and number of strings can be varied, allowing for optimization in how the individual cells are configured. Output parameters of the capacitor that can be measured include the voltage, current, and power.

The flywheel model is based on data provided by the University of Texas, where flywheels were developed for the EMALS (Electromagnetic Aircraft Launch System) system onboard the Ford class carrier. Two key parameters that can be optimized are the rotational speed, measured in revolutions per minute (RPM), and the inertia of the device. Care must be taken, as size and stress constraints make the two parameters dependent upon one another. A large flywheel with a large rotational speed may not be feasible. The linear speed at the tip of the wheel, called the tip speed, greatly affects the stresses in the wheel. These stresses limit tip speed and thus rotational speed. A spreadsheet provided by UT-CEM was used in optimizing the design of the flywheel to ensure feasibility.

The last major module is the laser. The voltage and output power of the laser can be adjusted. A resistor is used to represent the laser power output with another resistor in series to represent the heat losses. The pulse length and duty cycle of the laser can be adjusted to represent various scenarios. Figure 8 shows the adjustable graphical representation of the pulse structure. In this case, four six-second pulses with a 33% duty cycle were used.

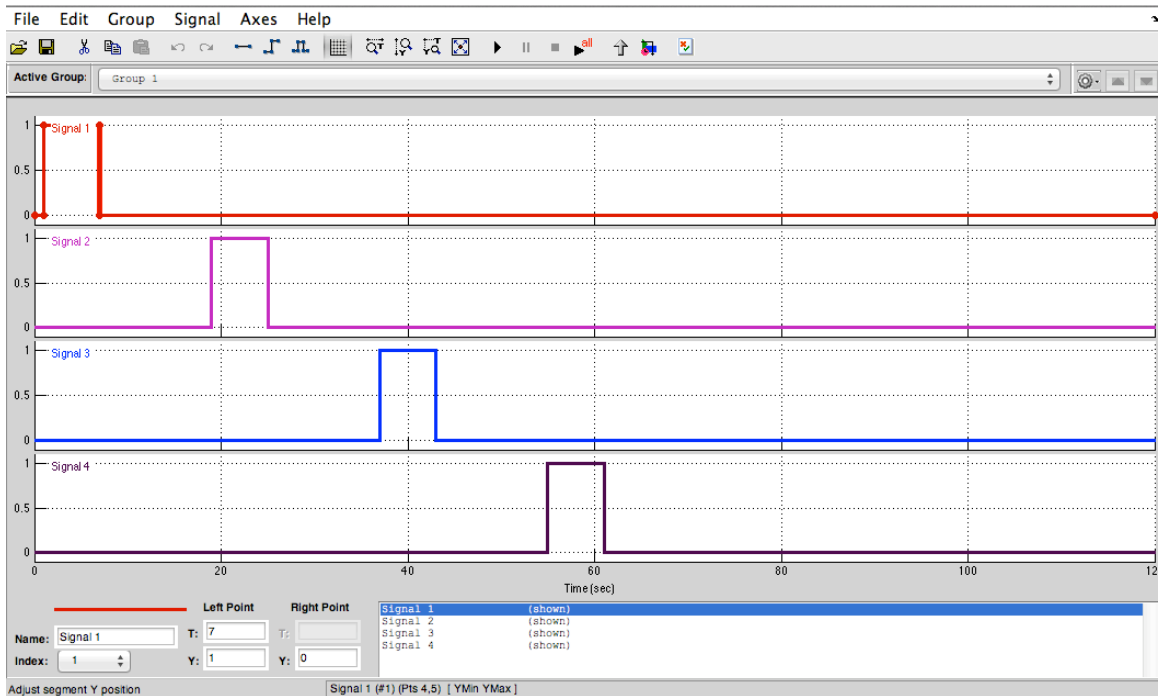

Figure 8. Adjustable pulse structure of the laser output in Simulink

Other components in the simulation include automatic bus transfers, transformers, power converters, and switches. Other parameters that are adjustable include run-length times and time step size for the simulation.

The complexity of the model can lead to long simulation times. One ten-second simulation typically takes ~15 minutes of computation time even when run in an accelerated mode. To simplify optimization runs, the ship, which is the most complex module, can be replaced by a simple three-phase AC source. This reduces a 10 second simulation down to just a couple minutes at a minimal loss in accuracy. This was verified by comparing a number of simulation runs with the simplified model to the same runs with the full model; the results are virtually identical in each case. Using the simplified model, numerous runs can be conducted to optimize an energy storage method against several powers and voltages for the lasers operated at different pulse lengths and duty cycles. Once an energy storage method has been optimized, the results can be run with the full ship to test the laser effects on the ship's systems. Once the four energy storage methods have been optimized, they can then be compared. Finally, the

model can be run without the energy storage to test the ship's ability to sustain the laser on its own.

V. ANALYSIS AND RESULTS

Several key questions to be considered in this study are:

- 1) For each energy storage method, what configuration gives the operator the best chance at winning an engagement?
- 2) Which energy storage method is the most space and weight effective?
- 3) How do the energy storage methods compare in reliability and safety?

In answering the first question, we apply the scenario that the operator must defeat multiple incoming targets and replace the spent energy. To this end, several series of simulations have been run, varying pulse length, duty cycle, and laser output power. Also, recharge time is important, so a run is performed for each energy storage method with the initial condition of being totally depleted. The time to recharge to 100% is then measured.

A. LEAD ACID ENERGY STORAGE RESULTS

The lead acid battery has the benefit of being very energy dense and provides power at an adequate rate, but is very slow to recharge. The battery was modeled to have 1, 2, or 3 strings of 100 cells. Two laser pulse lengths of three and six seconds were used. Also, two laser duty cycles at 50% and 33%, (i.e., 3 second on and 3 seconds off for the 50% duty cycle) were explored.

Figure 9 displays the resulting battery State Of Charge (SOC) versus time. The simplified model was used where the ship was replaced by an ideal source to shorten simulation time. The graph of the SOC over time can be extrapolated to find the number of pulses that can be fired before the battery is depleted. "Depleted" for the lead acid battery will be assumed to be 60%, below which significant performance degradation may occur.²⁸

²⁸ Michael A. Woehrman, "Power Systems Analysis of a Directed Energy Weapon System for Naval Platforms." (MS Thesis, Naval Postgraduate School, 2013).

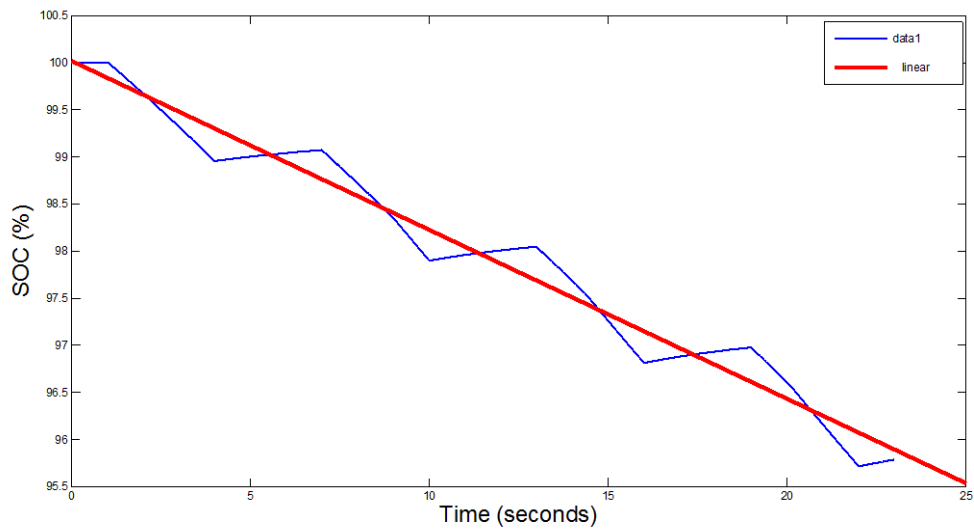

Figure 9. State of charge versus time over four pulses for a 125 kW laser with a 3 second pulse, 50% duty cycle, with one string of 100 lead-acid batteries. The red line represents a linear fit to the blue SOC data.

The pattern suggests that there is an approximately linear decrease in battery SOC with each pulse. A linear fit will provide an equation for SOC over time. Once this equation is known, an estimated number of shots can be calculated for each scenario.

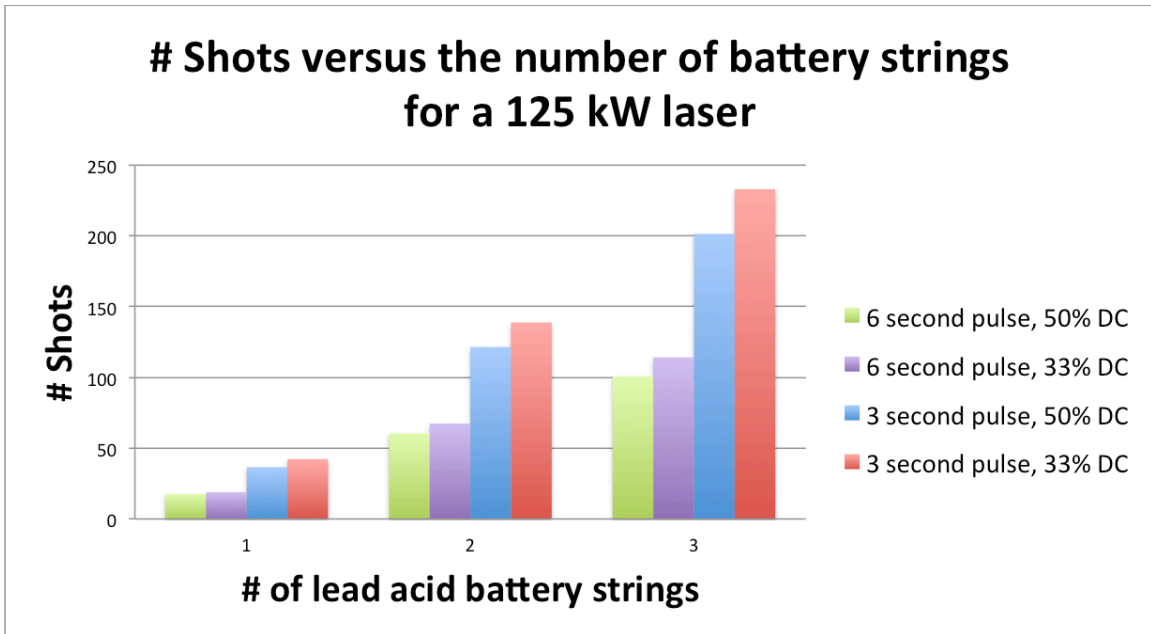

Figure 10. The number of 125 kW laser pulses (shots) until depletion for different duty cycles and pulse lengths, for 1, 2, or 3 strings of 100 lead-acid batteries.

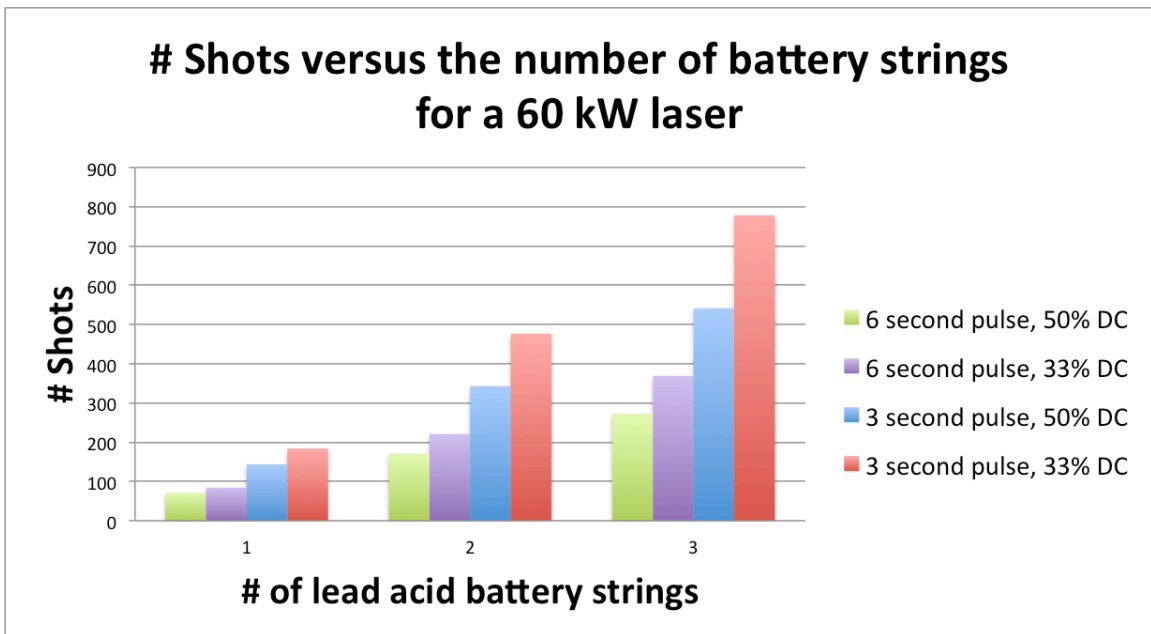

Figure 11. The number of 60 kW laser pulses (shots) until depletion for different duty cycles and pulse lengths, for 1, 2, or 3 strings of 100 lead-acid batteries.

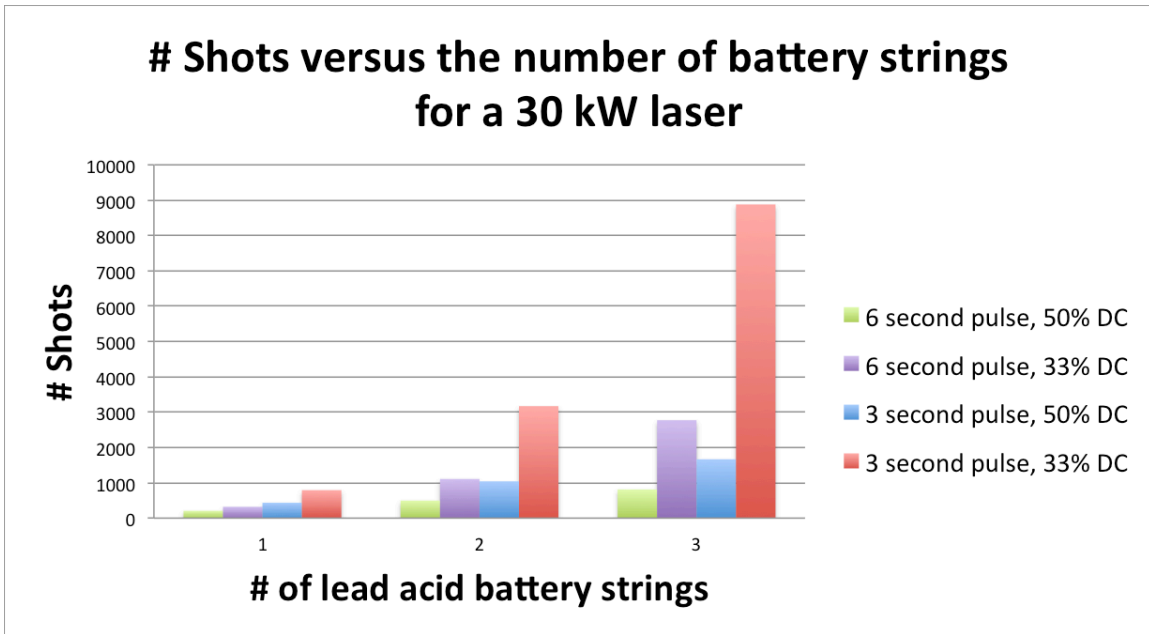

Figure 12. The number of 30 kW laser pulses (shots) until depletion for different duty cycles and pulse lengths, for 1, 2, or 3 strings of 100 lead-acid batteries.

For a typical engagement a longer pulse of 6 seconds would likely be needed to defeat many incoming threats. It is also preferred to have a higher duty cycle, since this will allow the operator to deliver more shots in the time needed to defeat a small swarm of ~50 targets. The results shown in Figures 10–12 indicate that for a 125 kW laser, 2 strings of batteries would be required, while for a 60 kW laser, 1 string would suffice. Later it will be shown that it may be possible to power the 30 kW laser directly from the ship’s electrical system, without any energy storage. An analysis and comparison of size, capability, and benefits will be performed at the end of this chapter.

B. LITHIUM ION ENERGY STORAGE RESULTS

The lithium ion model will use 270 battery cells per string to provide the necessary 1000 V at the output of the battery module. The number of strings in parallel will be varied from 1 to 4 for the 50% and 33% duty cycle cases. Unlike lead acid batteries, lithium ion batteries can tolerate deep discharges, so they will

be considered depleted at the lower value of only 20% state of charge.²⁹ The simplified model with an idealized AC source will be used to conduct multiple runs of the simulation.

The results for each of the lasers are summarized in Figure 13 and Figure 14. The results from the 30 kW laser are not included because even one string of batteries would recharge completely before the next shot began. This is an indication that the 30 kW laser may not require energy storage, as it would take as much power to recharge the battery this quickly as it would to just operate the laser using the ship's electrical power directly. A simulation will be presented later without energy storage to test this hypothesis. The results for the 60 kW laser also show little need for energy storage. One string of cells supplies 80 shots in the most limiting scenario tested (6-second shots with a 50% duty cycle). It can be seen that 2 strings of batteries supplies the 125 kW laser with 60 shots, each lasting 6 seconds, which is comparable to the lead acid battery configuration recommended in the previous section. If the length of the shots was reduced to 3 seconds then there would be roughly double the number of shots for the same duty cycle.

²⁹ Walter van Schalkwijk and Bruno Scrosati, *Advances in Lithium-Ion Batteries*. (Hingham: Kluwer, 2002).

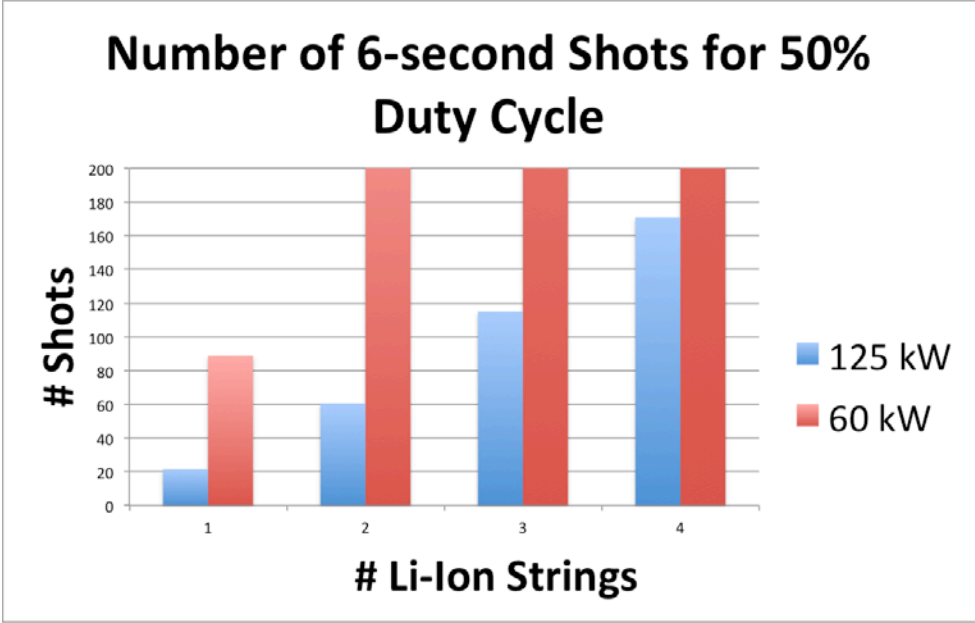

Figure 13. The number of 6-second shots available until 20% state of charge is reached, for various numbers of Li-ion battery strings. A 50% duty cycle was used in each case. The 60 kW laser exceeded 200 shots in the 2, 3, and 4 string cases.

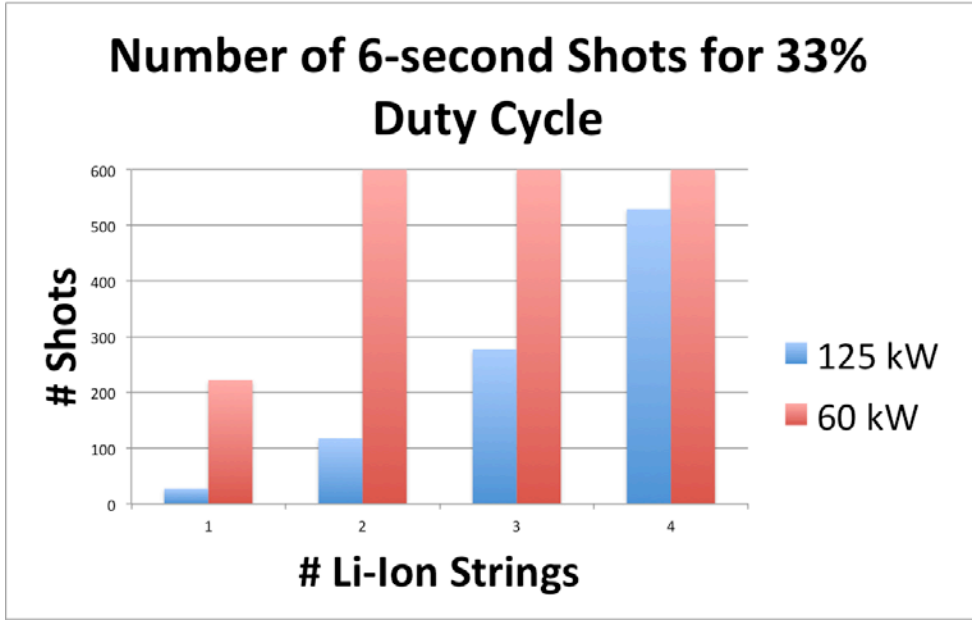

Figure 14. The number of 6-second shots available until 20% state of charge is reached, for various numbers of Li-ion battery strings. The 60 kW laser exceeded 200 shots in the 2, 3, and 4 string cases. A 50% duty cycle was used in each case.

C. FLYWHEEL ENERGY STORAGE DESIGN AND RESULTS

1. Flywheel Design

Equation 1 can be used to calculate flywheel energy, where E_k is the kinetic energy of the flywheel, I is the moment of inertia, and ω is the angular velocity.³⁰ The amount of energy stored will determine how many shots may be fired using that flywheel. It can be seen from this equation that the dominant effect on energy is the angular speed rather than the inertia, making faster spinning flywheels of the same size desirable.

$$E_k = \frac{1}{2} I \omega^2 \quad (1)$$

Equation 2 gives the moment of inertia of a solid cylinder of mass m and radius r . For a given radius mass can be increased by using denser materials and/or increasing the length of the flywheel. An increase in radius will have a squared effect similar to increasing angular velocity, but it is preferable to increase speed rather than radius since the latter would rapidly increase the size of the rotor.³¹

$$I = \frac{1}{2} m r^2 \quad (2)$$

The maximum speed and size of the flywheel is limited by the construction details and by the material properties of the rotor. A practical value for the maximum tip speed (linear speed at the outermost edge of the flywheel) is $v_{max} = 1200$ m/s for composite flywheels and 300 m/s for compact metal flywheels with composite banding that often incorporate the motor generator into the rotor.³² Equation 3 gives the tensile stress on a flywheel where ρ is the flywheel density.

$$\text{Tensile stress} = \sigma = \rho r^2 \omega^2 \quad (3)$$

³⁰ David Halliday, Robert Resnick, and Jearl Walker, *Fundamentals of Physics*, 9th edition, (Hoboken: Wiley, 2010).

³¹ Ibid.

³² Angelo L. Gattozzi, Phone conversations in the month of January, 2014.

It is often desirable to maximize the energy stored for a given weight of the flywheel material (for example, one of the reasons is to alleviate the design of the bearings). Therefore, considering the energy stored per unit mass of the flywheel and using the formulas above we obtain equation 4.

$$\frac{E}{m} = \frac{\sigma}{4\rho} \quad (4)$$

Therefore, using materials with greater tensile strength to density ratio achieves a higher gravimetric-energy-storage-density in a flywheel. This favors the use of carbon fiber composites, which have the highest such ratio.³³ Based upon the maximum tip speed, the maximum radius for a given angular velocity can be determined from $r_{max} = v_{max}/\omega$.

The flywheels upon which the simulations are based are made from graphite epoxy composites. These layers experience a shear stress, σ_{shear} , between them when there is a torque on the flywheel, i.e., when power is transmitted to or from the rotor. Shear stress is defined as the force F divided by the cross-sectional area A ; it is a function of torque τ , flywheel radius r , and flywheel length l .³⁴

$$\sigma_{shear} = \frac{F}{A} = \frac{\tau}{rA} = \frac{\tau}{r^2 2\pi l} \quad (5)$$

The value of the maximum shear stress for these models is 86 kN/m².³⁵ It can be seen from this equation that if the maximum radius is determined by the rotational frequency of the flywheel. The torque is determined by the desired maximum power according to $\tau = P_{max}/\omega$, so there is a minimum length that must be met to limit the shear stress.

$$l_{min} = \frac{P_{max}}{2\pi r^2 \sigma_{shear,max} \omega} \quad (6)$$

³³ Ibid.

³⁴ Ali Abdul-Aziz, *Structural Analysis of Composite Flywheels: An Integrated NDE and FEM Approach* (Hanover, MD: National Aeronautics and Space Administration, Glenn Research Center, 2001).

³⁵ Angelo L. Gattozzi, Phone conversations in the month of January, 2014.

Based upon a desired maximum power and minimum energy stored, a value for maximum radius and minimum length can be calculated. This provides the physical dimensions and operating characteristics needed to design realistic flywheels for these simulations. The following equations result in an expression that calculates the energy stored as a function of radius, length, and angular velocity.

$$m = \rho(\pi r^2 l) \quad (7)$$

$$I = \frac{\rho}{2} \pi r^4 l \quad (8)$$

$$E = \frac{\rho}{4} \pi r^4 l \omega^2 \quad (9)$$

2. Flywheel Energy Storage Results

The energy of the spinning rotor can be converted almost instantaneously to and from electrical power. When a flywheel is operated in a vacuum on a magnetic bearing there is essentially no friction. Rather than the recharge rate being limited by chemical processes (as in a battery), the flywheel recharge rate is only limited by the design of the motor/generator and the supplied power. Although each specific case must be examined in its own right, a typical recharge rate for flywheel energy storage is on the order of minutes. A good ballpark figure for a flywheel is a recharge rate of ~1% of its maximum speed per second.³⁶

As was done for the battery, simulations of four pulses and varying duty cycles and pulse lengths will be performed. The desired data from these runs will be the number of shots attained from each design. Rapid runs will be performed using the idealized source of power rather than the full ship model. A 1% per second recharge rate will be assumed so that the loss in rotational speed over time can be calculated. This is an approximation based upon flywheels at UT-CEM. Since the kinetic energy of a rotating mass is proportional to the square of its rotational speed, ~75% of the flywheel's energy will be depleted at ~50% of its

³⁶ Ibid.

maximum rotational speed. Although there is no operational restriction in slowing a flywheel to zero RPM, it will be considered depleted once the rotational speed reaches ~50%.

a. 125 kW Laser Simulations

Table 1 show the different flywheel designs considered for the 125 kW laser simulations. Various powers and speeds were chosen to optimize the design of the flywheel for the given scenarios.

Power (MW)	Max Speed (RPM)	Radius (m)	Length (m)	Inertia (kg*m ²)	Energy Stored (MJ)
17	3000	0.96	0.11	1127.5	55.6
	6000	0.48	0.22	140.9	27.8
	12000	0.24	0.44	17.6	13.9
8.5	3000	0.96	0.06	563.7	27.8
	6000	0.48	0.11	70.5	13.9
	12000	0.24	0.22	8.8	7.0
4	3000	0.96	0.03	281.9	13.9
	6000	0.48	0.06	35.2	7.0
	12000	0.24	0.11	4.4	3.5

Table 1. Various Flywheel designs tested for the 125 kW laser.

Figure 15 shows the number of shots that can be fired for each flywheel in Table 1, until it reaches 75% energy depletion, assuming a 1% recharge rate. The largest flywheel, 17 MW at 3000 RPM, was more than sufficient in meeting the power needs, but would place a large load on the ship’s service electrical plant during recharge (this effect will be investigated in a later section). The 4MW flywheel was inadequate. In the simulations for smaller power lasers, other flywheels with less power will be used, but in this case either the 8.5 MW flywheel at 3000 RPM or the 17 MW flywheel at 6000 RPM has enough energy to supply 60 6-second laser shots at a 50% duty cycle before depletion, and is comparable to the lead acid battery. This will also satisfy the 3-second pulse scenarios.

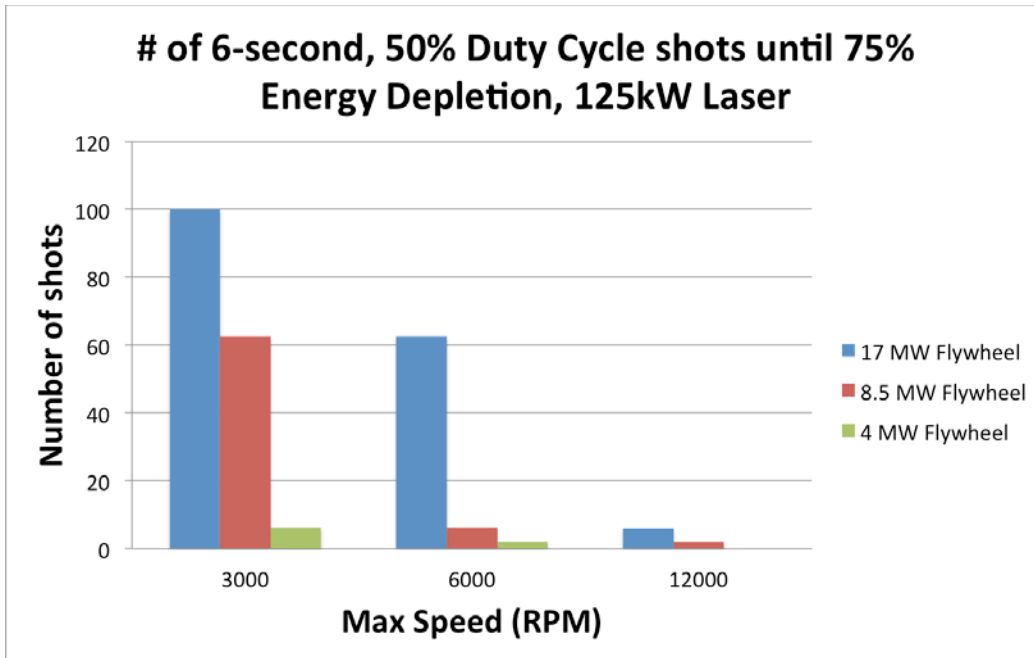

Figure 15. Number of 6-second shots each flywheel design could supply to a 125 kW laser at different rotational speeds.

b. 60 kW Laser Simulations

Table 2 shows the various flywheel designs considered for a 60 kW laser. Since the 17 MW flywheel was more than sufficient for the 125 kW laser, it was excluded for these simulations. For this case the three models tested were the 8.5, 4, and 2 MW flywheels.

Power (MW)	Max Speed (RPM)	Radius (m)	Length (m)	Inertia (kg*m ²)	Energy Stored (MJ)
8.5	3000	0.96	0.06	563.7	27.8
	6000	0.48	0.11	70.5	13.9
	12000	0.24	0.22	8.8	7.0
4	3000	0.96	0.03	281.9	13.9
	6000	0.48	0.06	35.2	7.0
	12000	0.24	0.11	4.4	3.5
2	3000	0.96	0.01	140.9	7.0
	6000	0.48	0.03	17.6	3.5
	12000	0.24	0.06	2.2	1.7

Table 2. Various flywheel designs tested for the 60 kW laser.

Figure 16 shows the number of six-second shots that can be consecutively fired using each flywheel design from Table 2. Either the 4 MW, 3000 RPM flywheel or the 8.5 MW, 6000 RPM flywheel has sufficient capacity to supply the 60kW laser.

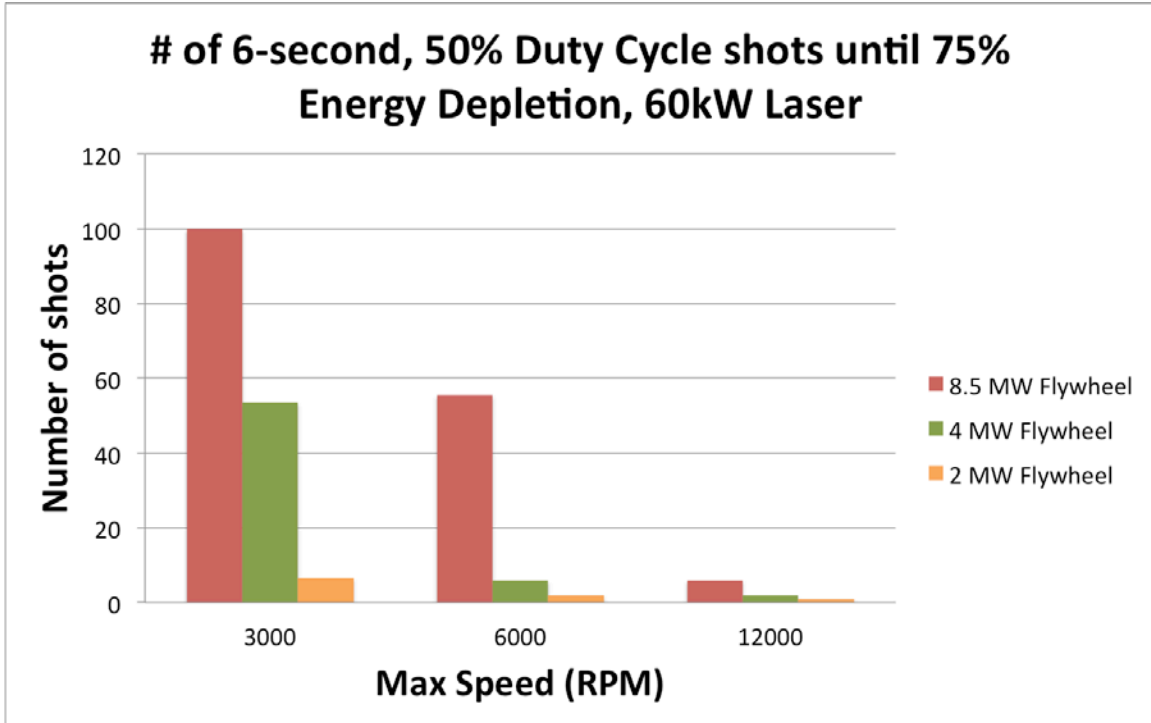

Figure 16. Number of 6-second shots each flywheel design could supply to a 60 kW laser at different rotational speeds.

c. 30 kW Laser Simulations

Table 3 shows the different flywheel designs considered for the 30kW laser. Since the 4 MW flywheel was sufficient for the 60kW laser, the higher power flywheel models will not be considered for this case.

Power (MW)	Max Speed (RPM)	Radius (m)	Length (m)	Inertia (kg*m ²)	Energy Stored (MJ)
4	3000	0.96	0.03	281.9	13.9
	6000	0.48	0.06	35.2	7.0
	12000	0.24	0.11	4.4	3.5
2	3000	0.96	0.01	140.9	7.0
	6000	0.48	0.03	17.6	3.5
	12000	0.24	0.06	2.2	1.7
1.0	3000	0.96	0.01	66.3	3.3
	6000	0.48	0.01	8.3	1.6
	12000	0.24	0.03	1.0	0.8

Table 3. Various flywheel designs for the 30 kW laser.

Figure 17 shows the number of shots that each of the flywheel designs from Table 3 could support. The 2 MW, 3000 RPM flywheel or the 4 MW, 6000 RPM flywheel provides sufficient energy to deliver the number of shots comparable to the lead acid battery.

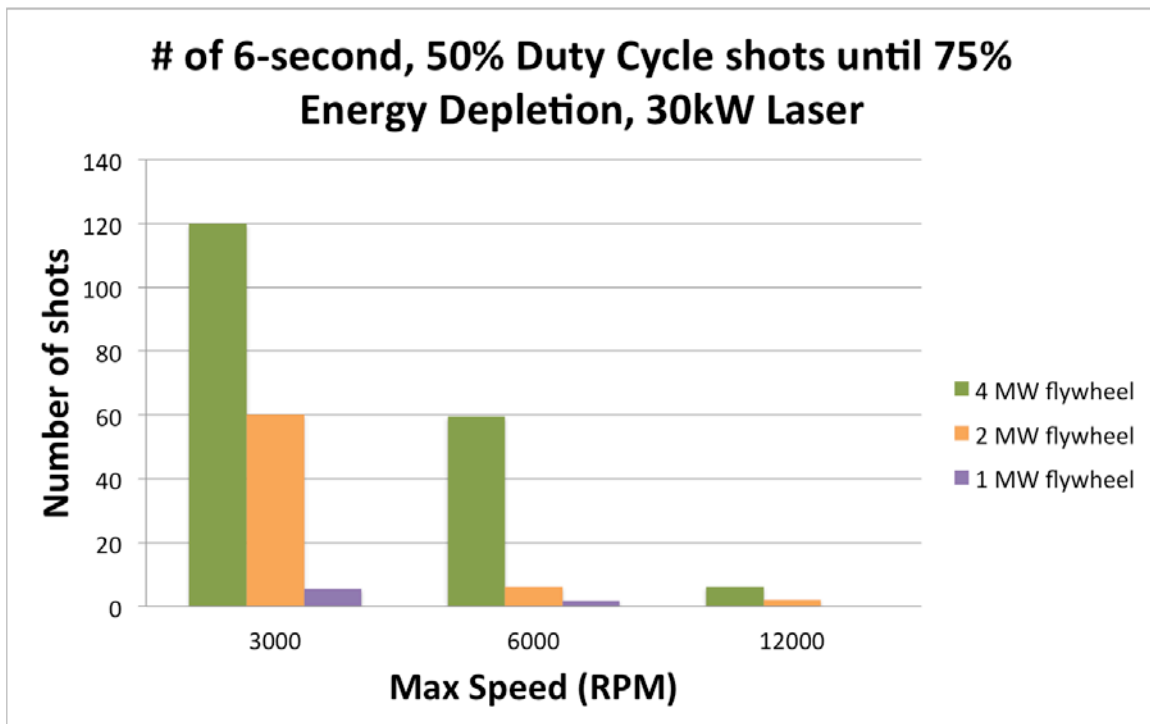

Figure 17. Number of 6-second shots each flywheel design could supply to a 30 kW laser at different rotational speeds.

Figures 15–17 show that doubling the angular speed of a flywheel and doubling the power can obtain the same number of shots. This results in a smaller radius but a larger length to maintain the same volume, inertia, and ultimately the same energy stored. The decision for which flywheel to use onboard a ship depends on the shape and speed desired. Large turbines spinning at thousands of RPM already exists onboard ships, the ship's service turbine generator and the gas turbine engines being the most common examples, so these devices are not breaking new ground as far as high speed, high energy machinery is concerned.

These simulations have demonstrated one result that could have been predicted: a laser with half the power only requires a flywheel of half the length and stored energy when operated at the same rotational speed in order to produce the same number of shots. One of the purposes of these runs is to help choose the appropriate flywheel design for a given laser power. Another purpose is to verify the accuracy of the model under different conditions. For various laser powers and flywheel designs the model has performed as expected, and now these devices can be run in the full model to see the effect on the ship's systems.

D. RESULTS WITH THE FULL MODEL OF THE SHIP

Thus, far the results have been derived from a simplified model using an ideal AC source rather than the full model of the ship's electrical system. This saved hundreds of hours running simulations, but does not answer the question as to how the ship's electrical systems are affected by the laser and the energy storage. One can design the world's largest flywheel to meet all of the laser's power needs, but this does not describe the effect on the ship when it needs to be recharged. This section reintegrates the full ship model into the simulation and investigates the changes in the ship's DC bus voltage, current, and power load due to the laser and recharging of the energy storage.

It is important to minimize the effect on the ship's DC bus because a severe drop in voltage may affect many of the ship's systems. Figure 18 shows the change in the ship's DC bus voltage over time for a six second, 125 kW laser pulse. Nominal bus voltage for this case is 1400 volts. Figure 19 displays current from the ship to the battery. The laser pulse begins at 1 second and ends at 7 seconds. While the laser is on it is taking power from the energy storage and the ship is unaffected. At the end of the pulse the battery begins to recharge and there is a drop in bus voltage with a rise in current to the energy magazine. The drop in DC bus voltage is largest at the start of the recharge cycle and then steadily decreases as the battery is recharged.

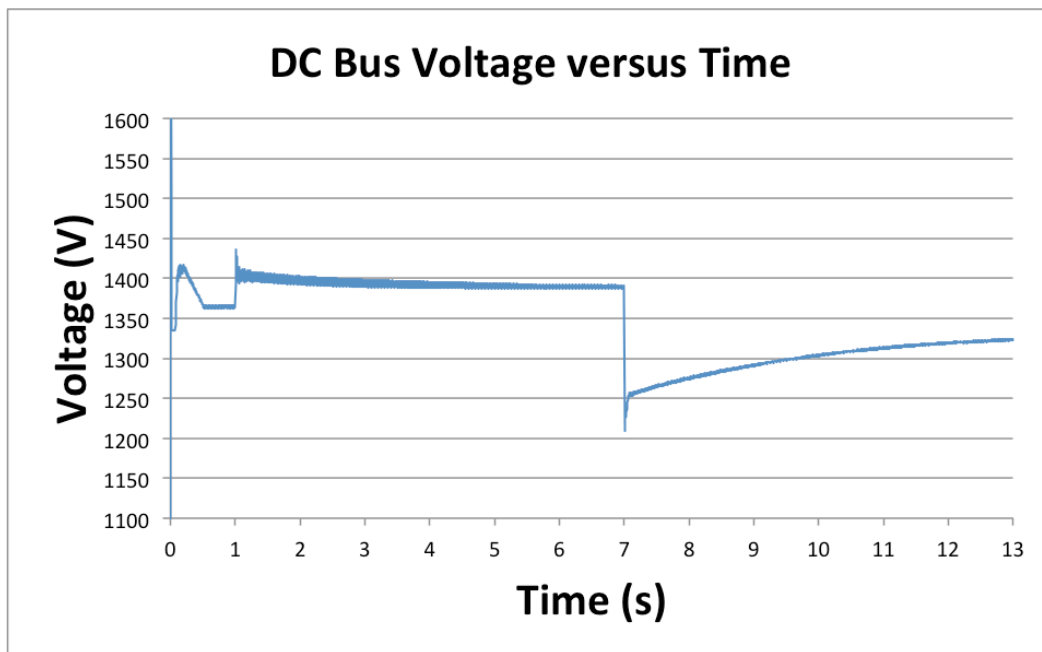

Figure 18. DC bus voltage over time for a 125 kW laser and 1 string of lead acid batteries. At 1s a laser pulse turns on. At 7s the laser pulse turns off and the begins to battery recharge. Initial spikes are due to instabilities the model experiences when all of the ship's systems are initially turned "on."

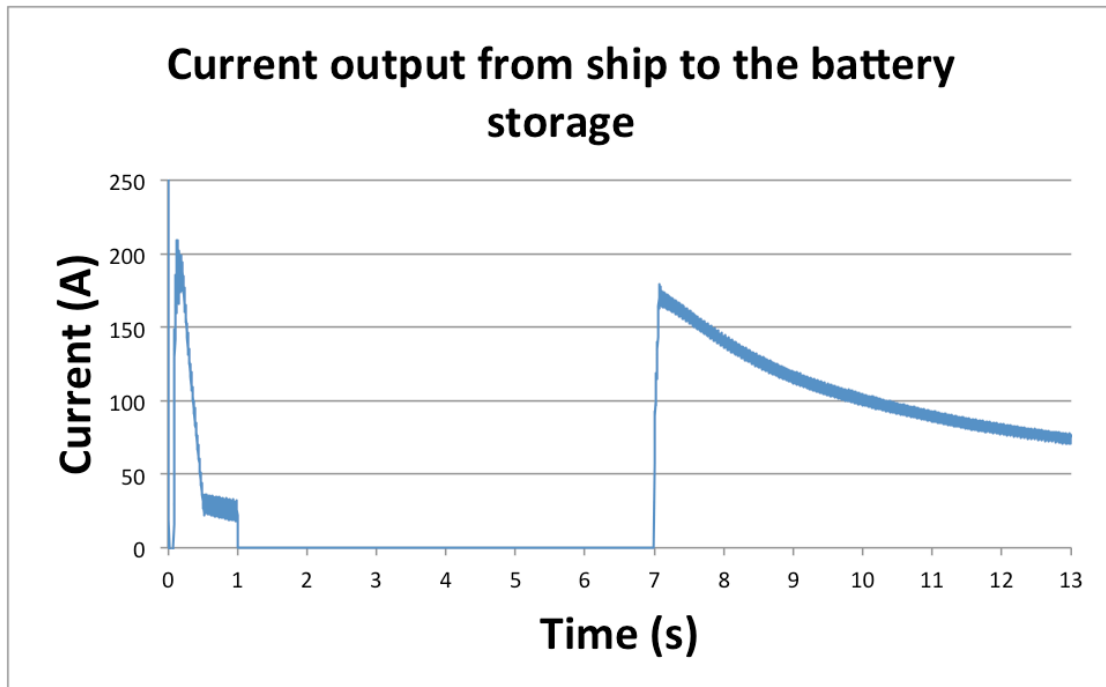

Figure 19. Current output from the ship to the lead acid battery as a function of time. A laser pulse was initiated at 1s and ended at 7s, when current spiked to begin recharging the batteries. Initial spikes are due to instabilities the model experiences when all of the ship's systems are initially turned "on"

The full ship model was run with each of the recommended battery storage configurations. The resulting changes on the ship's electrical systems are summarized in Table 4.

LEAD ACID				
Laser Power	Battery Configuration	Maximum DC Bus Voltage Drop (%)	Ship's Power to the Battery (kW)	Ship's Maximum Current to the Battery (A)
125 kW	2 Strings of 100 cells	7	130	100
60 kW	1 String of 100 cells	6	120	90
30 kW	No energy storage	13	-	-
LITHIUM ION				
Laser Power	Battery Configuration	Maximum DC Bus Voltage Drop (%)	Ship's Power to the Battery (kW)	Ship's Maximum Current to the Battery (A)
125 kW	2 Strings of 270 cells	11	340	320
60 kW	1 String of 270 cells	12	270	250
30 kW	No energy storage	13	-	-

Table 4. Resulting changes in ship's key electrical parameters during the recharge cycle of the lead acid and lithium ion batteries. For the 30 kW laser with no energy storage the maximum DC bus voltage Drop was due to the laser pulse, since there is no energy storage.

It can be seen that there is a roughly 10–12% DC bus voltage drop with each of the recommended configurations. Many loads on the ship draw power from the DC bus and a change in voltage can affect their performance. This voltage drop was largest at the start of recharge and diminished as the battery approached its fully charged state. A string of lithium ion batteries are a larger load than a string of lead acid batteries because of a faster recharge time. The power requirement during recharge affects other systems because there is only a finite amount of power supplied from the turbine generators. The same is true for the current draw by the battery. These results confirm that 2 strings of either type of battery will suffice to supply the 125 kW laser while minimizing the effect on the ship's system during recharge. Similarly for the 60 kW case just one string will be adequate, while no energy storage may be necessary for the 30 kW laser.

In the case of the flywheel the full ship model was not evaluated. The current recharge curve of the model is not characteristic of an actual flywheel and is being revised. As can be seen on Figure 20 the flywheel angular speed initially spikes back toward its initial value before leveling off. Future versions of the model are being developed that will refine this into a more realistic recharge.

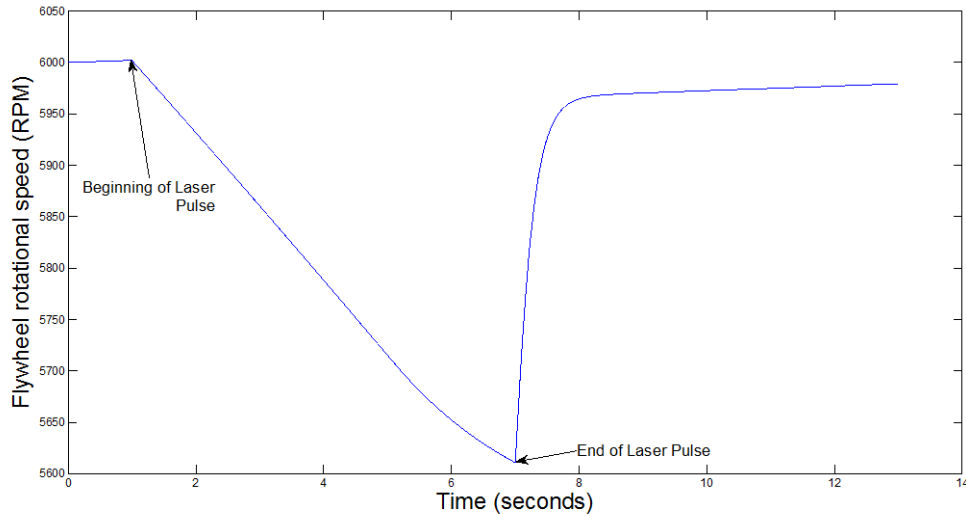

Figure 20. Typical discharge and recharge curve for a flywheel's speed in RPM (FWRPM) for the energy storage model used for simulations, for a 6 second, 125 kW laser pulse beginning at $t=1$ s.

E. TRANSIENTS AND INSTABILITIES

The careful modeling of the ship and laser permits the analysis of fast transients induced on the system buses. Furthermore, the model allows one to test different configurations of the system to reduce any potentially harmful transients. For example, an early version of the model produced the output waveform seen in Figure 21. The spikes at the beginning of the waveform are due to non-ideal capacitor values within a power converter. Varying the capacitance within this component reduced these spikes and the result is seen in Figure 22.

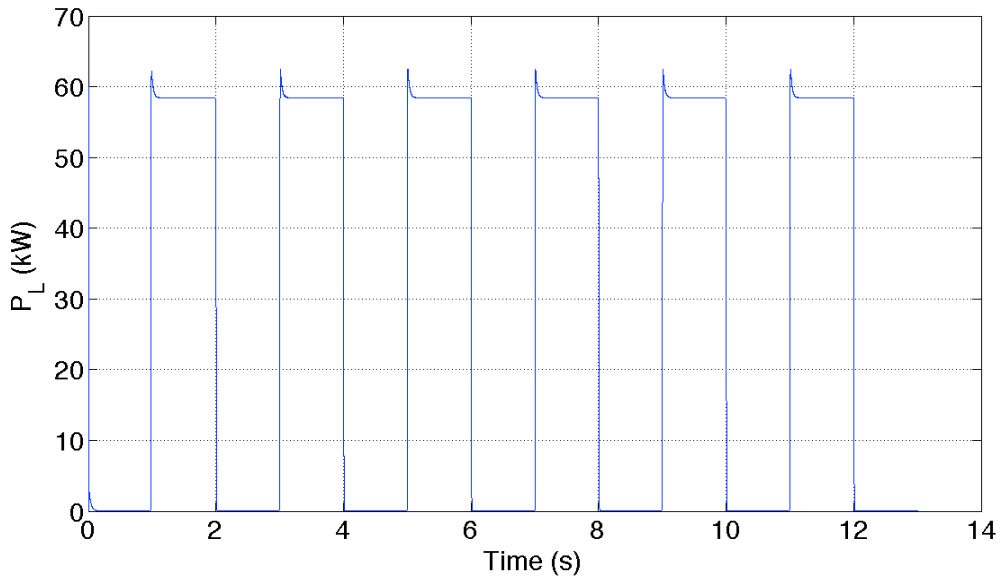

Figure 21. The power output of the laser. Each pulse is a firing of the laser.

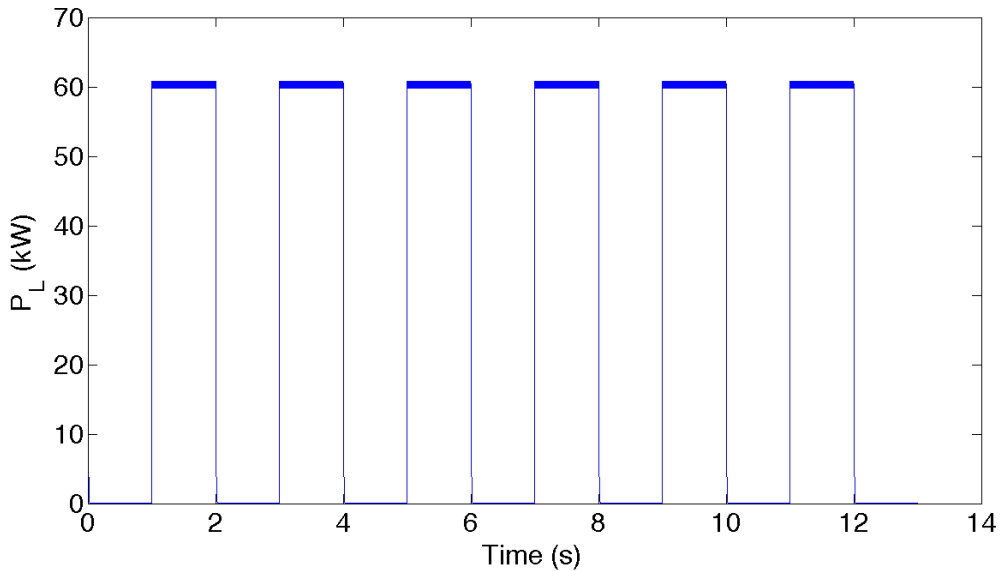

Figure 22. Power output from a laser after adjustment to the capacitance in the power converter leading to the laser.

After adjustments were made spikes in Figure 21 were eliminated; at this point a new effect was noticed. At the top of each pulse in the new output was a high frequency “fuzz” or “hash.” An investigation of these effects is necessary to

determine whether the effect is real or a product of the simulation. Figures 18 and 19 also show a high frequency oscillation. Zooming in on the current trace in Figure 19 while the battery is recharging shows the cyclic nature of the oscillation.

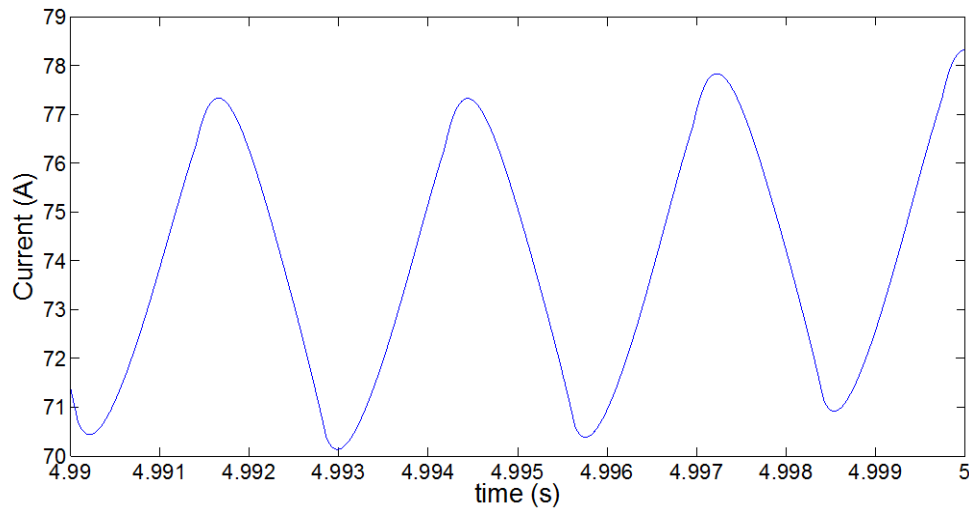

Figure 23. Current to a lead acid battery while recharging. The 0.003 millisecond period correlate to a 360 Hz oscillation.

The frequency of this oscillation has been determined to be ~360 Hz. This correlates to the rectification used to convert AC to DC. Future studies will include more analysis of these kinds of transients.

VI. CONCLUSIONS

Naval ships, especially older platforms, were not built to deliver the power necessary to sustain use of a high-powered laser. While the first laser onboard a naval ship will be ~30 kW, much higher power lasers may be incorporated at a later date. Some form of energy storage will be needed if the ship's power generation cannot support a new, pulsed load on the order of hundreds of kilowatts.

For this thesis, numerous simulations were conducted of a ship's electrical system, incorporating various laser power levels and several types of energy storage: lead-acid and lithium-ion batteries, and flywheels. The resulting suggestions for the size of energy magazines for different power lasers are summarized in Table 5, along with their volume and weight. Each method has its advantages and disadvantages. Ideally, if an energy magazine is incorporated into the ship's electrical system, it would also support other planned loads, such as the new rail gun that may be installed onboard ships at some point in the future. In fact, energy storage can serve the following additional purposes, when not needed for its primary intent of powering pulsed loads:

- 1) Function as an uninterruptible power supply (UPS) for the ship's power system in case of temporary loss of any of the normal power sources
- 2) Function as a power ripple leveling when sudden loads are switched on and off the ship's power system.

That type of multiple purpose use may lead to a storage method that allows for rapid withdrawal of energy, such as capacitors or flywheels. Capacitors are not very energy dense, so a large number of cells would be needed to provide the energy required. The Navy is currently planning to deploy a large flywheel for energy storage with the EMALS system onboard the soon to be commissioned USS Ford. Batteries are a well-tested technology that has been used for decades and are continuing to be improved. As can be seen in Table 5,

a string of lithium ion batteries is approximately seven times smaller and ~9x lighter than a string of lead acid batteries. However, batteries are beset with safety issues, low power delivery, and high maintenance. To approve the use of lithium ion batteries after a multitude of battery fires may take years when other methods are readily deployable.

LEAD ACID			
Laser Power	Battery Configuration	Volume (m ³)	Weight (kg)
125 kW	2 Strings of 100 cells	1.90	5140
60 kW	1 String of 100 cells	0.95	2570
30 kW	No energy storage	0.00	0
LITHIUM ION			
Laser Power	Battery Configuration	Volume (m ³)	Weight (kg)
125 kW	2 Strings of 270 cells	0.26	551
60 kW	1 String of 270 cells	0.13	275
30 kW	No energy storage	0.00	0
FLYWHEEL			
Laser Power	Flywheel Configuration	Volume (m ³)	Weight (kg)
125 kW	8.5 MW, 3000 max RPM	0.16	1238
60 kW	4 MW, 3000 max RPM	0.08	608
30 kW	No energy storage	0.00	0

Table 5. Weight and volume requirements for the suggested configurations of energy magazines for various laser power levels. These are the minimum configurations required to deliver approximately sixty 6-second shots at a 50% duty cycle. Of note, the flywheel volume and weight is for the rotor only; the casing and motor generator will add to this.

Laser deployment on naval craft is a process in its infancy. Ships have not been made to support high power pulsed electrical loads. A string or two of batteries could provide all the energy an operator may need to fight off an engagement of small boats, drone aircraft, and incoming missiles. The recommendations listed here are based upon delivering roughly sixty, six-second shots at a 50% duty cycle before the energy magazine is depleted. The recharge

rate of batteries is limited by chemical reactions. Recharge rate for flywheels and capacitors is only limited by the power available from the ship.

Future work will include modeling and testing other ships such as the Zumwalt class destroyer and various littoral combat ships. Also, an accurate, working model of the capacitor energy bank is being developed and the flywheel model is being refined. As these methods are further developed and refined more precise data may be delivered to the designers and ultimately the fleet.

THIS PAGE INTENTIONALLY LEFT BLANK

LIST OF REFERENCES

- Abdul-Aziz, Ali. *Structural Analysis of Composite Flywheels: An Integrated NDE and FEM Approach*. Hanover, MD: National Aeronautics and Space Administration, Glenn Research Center, 2001.
- Acherman, Spencer. "Watch the Navy's New Ship Mounted Laser Cannon Kill a Drone." Accessed April 3, 2014. http://www.wired.com/2013/04/laser-warfare-system/?utm_source=rss&utm_medium=rss&utm_campaign=watch-navys-new-laser-cannon-mounted-on-a-ship-kill-a-drone.
- Battery University. "Advantages and Limitations of the Lithium-Ion Battery." Accessed April 5, 2014. http://batteryuniversity.com/learn/article/is_lithium_ion_the_ideal_battery.
- Brain, Marshal and Charles Bryant. "How Capacitors Work." Accessed May 10, 2014, <http://electronics.howstuffworks.com/capacitor.htm>.
- Energy Storage Association. "Flywheels." Accessed May 15, 2014. <http://energystorage.org/energy-storage/technologies/flywheels>.
- Halliday, David, Robert Resnick, and Jearl Walker. *Fundamentals of Physics, 9th edition*. Hoboken: Wiley, 2010.
- Kuseian, John. *Naval Power Systems Technology Development Roadmap PMS 430*. Washington, DC: Electric Ships Office PMS 320, 2013.
- La Fuente, Jesus. "Graphene Supercapacitors - what are they?" Accessed May 15, 2014. <http://www.graphenea.com/pages/graphene-supercapacitors#.U5JXhF5sApE>.
- Massachusetts Institute of Technology. "Archimedes Death Ray: Idea Feasibility Testing." Accessed March 14, 2014. http://web.mit.edu/2.009/www/experiments/deathray/10_ArchimedesResult.html.
- Office of Naval Research. "Navy Leaders Announce Plans for Deploying Cost-Saving Laser Technology." Accessed April 20, 2014. http://www.navy.mil/submit/display.asp?story_id=73234.
- Pavlov, Detchko. *Lead-Acid Batteries - Science and Technology - A Handbook of Lead-Acid Battery Technology and its Influence on the Product*. Amsterdam: Elsevier, 2011.

Sprangle, P., J. R. Peñano and A. Ting. "Propagation of High-Energy Lasers in a Maritime Atmosphere." *Naval Research Laboratory*, 2014, accessed April 5, 2014, <http://www.nrl.navy.mil/research/nrl-review/2004/featured-research/sprangle/>.

Stewart, Phil. "U.S. Navy to Field First Laser Weapon, could Shoot Down a Drone." *Reuters*, April 8, 2013, accessed April 3, 2014, <http://www.reuters.com/article/2013/04/08/us-usa-weapons-laser-idUSBRE93716Z20130408>.

Walter van Schalkwijk and Bruno Scrosati, *Advances in Lithium-Ion Batteries*. Hingham: Kluwer, 2002.

Wikipedia. "Nickel-Metal Hydride Battery." Accessed May 10, 2014. http://en.wikipedia.org/wiki/Nickel-metal_hydride_battery.

Woehrman, Michael A. "Power Systems Analysis of a Directed Energy Weapon System for Naval Platforms." MS Thesis, Naval Postgraduate School, 2013.

INITIAL DISTRIBUTION LIST

1. Defense Technical Information Center
Ft. Belvoir, Virginia
2. Dudley Knox Library
Naval Postgraduate School
Monterey, California