



**Calhoun: The NPS Institutional Archive**  
**DSpace Repository**

---

Theses and Dissertations

1. Thesis and Dissertation Collection, all items

---

2009-03

The technologies and principles needed for  
the powering of remote nodes in an  
interoperability network

Coudray, Aaron D.

Monterey, California. Naval Postgraduate School

---

<https://hdl.handle.net/10945/4847>

---

*Downloaded from NPS Archive: Calhoun*



Calhoun is the Naval Postgraduate School's public access digital repository for research materials and institutional publications created by the NPS community. Calhoun is named for Professor of Mathematics Guy K. Calhoun, NPS's first appointed -- and published -- scholarly author.

**Dudley Knox Library / Naval Postgraduate School**  
**411 Dyer Road / 1 University Circle**  
**Monterey, California USA 93943**

<http://www.nps.edu/library>



**NAVAL  
POSTGRADUATE  
SCHOOL**

**MONTEREY, CALIFORNIA**

**THESIS**

**THE TECHNOLOGIES AND PRINCIPLES NEEDED FOR  
THE POWERING OF REMOTE NODES IN AN  
INTEROPERABILITY NETWORK**

by

Chadrick Beidalah  
Aaron Coudray

March 2009

Thesis Advisor:	Rex Buddenberg
Second Reader:	Tom Housel

**Approved for public release; distribution is unlimited**

THIS PAGE INTENTIONALLY LEFT BLANK

REPORT DOCUMENTATION PAGE			Form Approved OMB No. 0704-0188	
Public reporting burden for this collection of information is estimated to average 1 hour per response, including the time for reviewing instruction, searching existing data sources, gathering and maintaining the data needed, and completing and reviewing the collection of information. Send comments regarding this burden estimate or any other aspect of this collection of information, including suggestions for reducing this burden, to Washington headquarters Services, Directorate for Information Operations and Reports, 1215 Jefferson Davis Highway, Suite 1204, Arlington, VA 22202-4302, and to the Office of Management and Budget, Paperwork Reduction Project (0704-0188) Washington DC 20503.				
1. AGENCY USE ONLY (Leave blank)		2. REPORT DATE March 2009	3. REPORT TYPE AND DATES COVERED Master's Thesis	
4. TITLE AND SUBTITLE The Technologies and Principles Needed for the Powering of Remote Nodes in an Interoperability Network			5. FUNDING NUMBERS	
6. AUTHOR(S) Beidalah, Chadrick J. Coudray, Aaron D.				
7. PERFORMING ORGANIZATION NAME(S) AND ADDRESS(ES) Naval Postgraduate School Monterey, CA 93943-5000			8. PERFORMING ORGANIZATION REPORT NUMBER	
9. SPONSORING /MONITORING AGENCY NAME(S) AND ADDRESS(ES)N/A			10. SPONSORING/MONITORING AGENCY REPORT NUMBER	
11. SUPPLEMENTARY NOTES The views expressed in this thesis are those of the author and do not reflect the official policy or position of the Department of Defense or the U.S. Government.				
12a. DISTRIBUTION / AVAILABILITY STATEMENT Approved for public release; distribution is unlimited			12b. DISTRIBUTION CODE	
13. ABSTRACT (maximum 200 words) <p>This thesis investigates the various power system solutions and options available for affording remote network nodes autonomy. The approach taken is to first identify the particulars of a network that affect the power needs and requirements of remote network nodes. Secondly, this thesis examines candidates, and combinations of those candidates, for fulfilling the power needs of the remote nodes. Additionally, monitoring and management of power sources are studied. The purpose and focus of the work contained in this research is to provide insight to how best incorporate remote node power systems into the design of an interoperability communications network.</p> <p>Communications and the ability to exchange data are heavily depended upon today. This fact can be considered just as true or even more so in the event of a disaster. In times of need, where rural regions do not possess the infrastructure to support this need, the dependency is significant. A solution to this need is being filled by developing communication and interoperability networks.</p> <p>In both the situation of rural application and regions suffering from disaster, the use of network equipment is often limited by the means available to electrically power the equipment. This issue can be further complicated in situations requiring such equipment to be positioned in locations absent from network operators. Remote network node power system solutions require methods and technologies to allow these nodes some independence in terms of its power requirements.</p>				
14. SUBJECT TERMS Power Generation, Remote Network Node, Interoperability Network, Electric Generator, Wind Power, Solar Power, Photovoltaic, Thermoelectric, Energy Storage, Fuel Cell, Hybrid Power, Power Monitoring, Power Management			15. NUMBER OF PAGES 141	
			16. PRICE CODE	
17. SECURITY CLASSIFICATION OF REPORT Unclassified	18. SECURITY CLASSIFICATION OF THIS PAGE Unclassified	19. SECURITY CLASSIFICATION OF ABSTRACT Unclassified	20. LIMITATION OF ABSTRACT UU	

THIS PAGE INTENTIONALLY LEFT BLANK

Approved for public release; distribution is unlimited

**THE TECHNOLOGIES AND PRINCIPLES NEEDED FOR THE POWERING OF  
REMOTE NODES IN AN INTEROPERABILITY NETWORK**

Chadrick J. Beidalah  
Lieutenant, United States Navy  
B.S., University of Washington, 2002

Aaron D. Coudray  
Lieutenant, United States Navy  
B.S., Tulane University, 2002

Submitted in partial fulfillment of the  
requirements for the degree of

**MASTER OF SCIENCE IN INFORMATION TECHNOLOGY MANAGEMENT**

from the

**NAVAL POSTGRADUATE SCHOOL  
March 2009**

Authors: Chadrick J. Beidalah

Aaron D. Coudray

Approved by: Rex Buddenberg  
Thesis Advisor

Tom Housel  
Second Reader

Dan C. Boger  
Chair, Department of Information Systems

THIS PAGE INTENTIONALLY LEFT BLANK

## ABSTRACT

This thesis investigates the various power system solutions and options available for affording remote network nodes autonomy. The approach taken is to first identify the particulars of a network that affect the power needs and requirements of remote network nodes. Secondly, this thesis examines candidates, and combinations of those candidates, for fulfilling the power needs of the remote nodes. Additionally, monitoring and management of power sources are studied. The purpose and focus of the work contained in this research is to provide insight to how best incorporate remote node power systems into the design of an interoperability communications network.

Communications and the ability to exchange data are heavily depended upon today. This fact can be considered just as true or even more so in the event of a disaster. In times of need, where rural regions do not possess the infrastructure to support this need, the dependency is significant. A solution to this need is being filled by developing communication and interoperability networks.

In both the situation of rural application and regions suffering from disaster, the use of network equipment is often limited by the means available to electrically power the equipment. This issue can be further complicated in situations requiring such equipment to be positioned in locations absent from network operators. Remote network node power system solutions require methods and technologies to allow these nodes some independence in terms of its power requirements.



THIS PAGE INTENTIONALLY LEFT BLANK

## TABLE OF CONTENTS

I.	INTRODUCTION .....	1
A.	PROBLEM DESCRIPTION .....	1
B.	RESEARCH OBJECTIVES .....	2
C.	ORGANIZATION .....	2
D.	SCOPE AND INTENDED USE .....	5
E.	EXPECTED BENEFITS .....	5
II.	SYSTEM SPECIFICATIONS .....	7
A.	BACKGROUND .....	7
1.	Interoperability Network .....	8
2.	Remote Network Nodes .....	10
B.	POWER REQUIREMENTS .....	11
C.	SYSTEM AVAILABILITY .....	11
III.	CONVENTIONAL ELECTRIC GENERATORS .....	13
A.	GENERAL .....	13
1.	Internal Combustion .....	13
2.	Petrol versus Diesel .....	15
B.	ADVANTAGES .....	16
C.	DISADVANTAGES .....	17
IV.	WIND POWERED GENERATORS .....	19
A.	BACKGROUND .....	19
B.	TYPES .....	22
C.	EQUIPMENT .....	26
D.	FEASIBILITY .....	29
E.	CONCLUSION .....	30
V.	PHOTOVOLTAIC SYSTEMS .....	33
A.	BACKGROUND .....	33
B.	TYPES .....	36
1.	Mono-Crystalline .....	37
2.	Poly-Crystalline .....	37
3.	Thin Silicon .....	38
4.	Amorphous Silicon .....	38
5.	Gallium Arsenide .....	40
6.	Other .....	40
C.	EQUIPMENT .....	42
D.	FEASIBILITY .....	43
E.	CONCLUSION .....	44
VI.	THERMOELECTRIC GENERATORS .....	47
A.	GENERAL .....	47
1.	Seebeck Effect .....	47
2.	Principles of Operation .....	48

3.	Commercial Thermoelectric Generators .....	49
B.	DEVELOPMENT AND HISTORY .....	50
C.	ADVANTAGES .....	51
D.	DISADVANTAGES .....	52
VII.	FUEL CELLS .....	55
A.	BACKGROUND .....	55
B.	TYPES OF FUEL CELLS .....	56
1.	Alkaline Fuel Cell .....	56
2.	Phosphoric Acid Fuel Cell .....	57
3.	Molten Carbonate Fuel Cell .....	57
4.	Solid Oxide Fuel Cell .....	58
5.	Direct Methanol Fuel Cell .....	58
6.	Polymer Electrolyte Membrane Fuel Cell .....	58
C.	FEASIBILITY .....	62
D.	CONCLUSION .....	62
VIII.	ENERGY STORAGE SYSTEMS .....	65
A.	GENERAL .....	65
B.	ENERGY STORAGE OPTIONS .....	65
1.	Electrical Energy Storage .....	66
a.	<i>Electrochemical Energy Storage</i> .....	66
b.	<i>Electric/Magnetic Field Energy Storage</i> ..	75
2.	Mechanical Energy Storage .....	76
3.	Thermal Energy Storage .....	78
C.	SUMMARY OF ENERGY STORAGE OPTIONS .....	79
IX.	HYBRID POWER .....	81
A.	BACKGROUND .....	81
B.	TYPES .....	83
C.	SYSTEM DESIGN .....	86
1.	Primary Power Source .....	86
2.	Secondary Power System .....	87
3.	Miscellaneous Components .....	88
4.	Complete System .....	89
D.	SYSTEM SIZING .....	90
1.	Economic Optimization .....	90
2.	System Component Optimization .....	91
E.	CONCLUSION .....	93
X.	POWER SYSTEM MONITORING AND MANAGEMENT .....	95
A.	GENERAL .....	95
B.	SIMPLE NETWORK MANAGEMENT PROTOCOL (SNMP) .....	96
1.	SNMP Components .....	96
2.	SNMP Operations .....	98
3.	Management Information Base (MIB) .....	99
4.	SNMP Versions .....	100
C.	USING SNMP TO IMPROVE AVAILABILITY .....	101

D.	REMOTE NODE POWER SOURCES AS SNMP MANAGED DEVICES	102
E.	SNMP SYSTEM MANAGEMENT .....	104
F.	IMPLEMENTATION OF SNMP IN ENERGY SYSTEM MANAGEMENT	105
XI.	CONCLUSIONS AND RECOMMENDATIONS .....	111
A.	SUMMARY .....	111
B.	CONCLUSIONS .....	111
C.	RECOMMENDATIONS FOR FUTURE RESEARCH .....	114
	LIST OF REFERENCES .....	117
	INITIAL DISTRIBUTION LIST .....	121

THIS PAGE INTENTIONALLY LEFT BLANK

## LIST OF FIGURES

Figure 1.	General Illustration of the Thermodynamic cycle of an Internal Combustion Engine. (From Britannica Student Encyclopaedia).....	14
Figure 2.	Dutch Windmill (From Kreith 2007).....	20
Figure 3.	Ancient Persian VAWT (From Kreith 2007).....	23
Figure 4.	Multi-Blade HAWT (From Kreith 2007).....	23
Figure 5.	Power Coefficient vs. TSR for Various Types of Wind Turbines (From Ahmed et al. 2009).....	25
Figure 6.	P-N Junction Showing Electron and Hole Drift and Diffusion (From Kreith 2007).....	34
Figure 7.	Amorphous (Thin) PV Film (From U.S. DoE 2007)...	39
Figure 8.	PV Cell Efficiencies (From Kreith 2007).....	41
Figure 9.	PV Cell, Module, Panel and Array (From Florida Solar Energy Center).....	42
Figure 10.	Basic Principle of Thermoelectric Conversion. (From Thermoelectrics.com).....	48
Figure 11.	Basic Fuel Cell Schematic (From Kreith 2007)....	56
Figure 12.	UltraCell XX25 Fuel Cell (From UltraCell Corporation).....	59
Figure 13.	Effect of CO on PEMFC (From Baschuk and Li 2001).....	60
Figure 14.	Schematic of a Generalized Secondary Battery. (From Kreith 2007).....	67
Figure 15.	Sample Battery Configurations Demonstrating the Relationship between Battery Interconnections and Battery Bank Output Capacities. (From Sundance Solar).....	73
Figure 16.	Ragone Plot Energy Density and Power Density of Various Electric Energy Storage Devices. (From The Electropaedia).....	79
Figure 17.	Equivalent Circuit of Hybrid Energy System (From Ahmed et al. 2009).....	88
Figure 18.	Hybrid Solar-Wind System Optimization Sizing Flow Chart (From Yang et al. 2007).....	92
Figure 19.	Basic SNMP Network Management Architecture. (From Breakthrough Ltd.).....	97
Figure 20.	Simplified Wiring Schematic for the GreenMeter by WES Power Technologies. (Adapted From: WES Power Technologies).....	106
Figure 21.	Implementation Diagram for various sensors and probes in a network application. (Adapted From: AKCP Inc.).....	108

THIS PAGE INTENTIONALLY LEFT BLANK

## LIST OF TABLES

Table 1.	Commercially Available Thermoelectric Generators (From Rowe 1995).....	49
Table 2.	Comparison of Fuel Cell Technologies (Adapted From: Aabakken 2006).....	61
Table 3.	Summary of SNMP versions.....	101



THIS PAGE INTENTIONALLY LEFT BLANK

## LIST OF ACRONYMS AND ABBREVIATIONS

AC	Alternating Current
AFC	Alkaline Fuel Cell
AH	Ampere-hour
AWEA	American Wind Energy Association
CIGS	Copper Indium Gallium (Di)Selenide
CMIP	Common Management Information Protocol
CO	Carbon Monoxide
CO <sub>2</sub>	Carbon Dioxide
DC	Direct Current
DMFC	Direct Methanol Fuel Cell
DoE	Department of Energy
EERE	Energy Efficiency and Renewable Energy
FC	Fuel Cell
GaAs	Gallium Arsenide
HAWT	Horizontal Axis Wind Turbine
IP	Internet Protocol
LCE	Levelized Cost of Energy
LPSP	Loss of Power Supply Probability
MCFC	Molten Carbonate Fuel Cell
MIB	Management Information Base
MTU	Maximum Transmission Unit
NiCd	Nickel-Cadmium
NiMH	Nickel Metal Hydride

NMS	Network Management Station
NOC	Network Operating (Operations) Center
PAFC	Phosphoric Acid Fuel Cell
PDU	Protocol Data Unit
PEMFC	Polymer Electrolyte Membrane Fuel Cell
PV	Photovoltaic
RFC	Request for Comments
S	Sulfur
Si	Silicon
SMI	Structure of Management Information
SNMP	Simple Network Management Protocol
SOFC	Solid Oxide Fuel Cell
TCP/IP	Transport Control Protocol and Internet Protocol
TEG	Thermoelectric Generator
TSR	Tip Speed Ratio
UC	Ultra capacitor
UDP	User Datagram Protocol
UPS	Uninterrupted Power Supply
VAWT	Vertical Axis Wind Turbine
WiMAX	Worldwide Interoperability for Microwave Access
WT	Wind Turbine

## ACKNOWLEDGMENTS

We would like to express our gratitude and appreciation to our thesis advisors for their valuable time and effort spent in providing us feedback and direction on our work to ensure the most professional product possible. In addition, our gratefulness extends to all of the Naval Postgraduate School faculty and staff that have educated and assisted us throughout our classes and thesis work here. Our classmates and peers also deserve acknowledgement for their participation in our studies as well as our lives. We would like to pay special tribute to Mike "Big John" Thorpe. Without his personal guidance and assistance, our time here at the Naval Postgraduate School could not have been as memorable as it was. His philosophy of "when the going gets tough, the tough turn to port" has provided us with the drive and motivation to overcome all the trials and tribulations that confronted us during our time in Monterey.

We would also like to pay special thanks to our families for their support and encouragement during our time here at the Naval Postgraduate School and their patience throughout our naval careers. Our successes, in career and life, are attributed to their care and sacrifice.

THIS PAGE INTENTIONALLY LEFT BLANK

## I. INTRODUCTION

### A. PROBLEM DESCRIPTION

In times of crisis and disaster, the need for communications is often as necessary as the basic need for food and shelter. Over the past decade, we have witnessed and experienced events in the U.S. and abroad that left disaster and crisis response plans impotent due to losses in communication infrastructure. These hard-learned lessons have left emergency response strategists scrambling to equip federal, state, and local agencies with the tools needed to effectively combat the next disaster.

Past and current disaster response plans include communications plans that rely heavily on the use of telephone and power infrastructure that pre-exists the disaster. However, the destruction of existing power and communications infrastructure and/or the need to reach remote areas that are underdeveloped, in terms of power and communications capabilities, raises the need for a capacity to establish such capabilities when needed.

One solution for addressing the communications need is the deployment of interoperability networks comprised of mobile Network Operation Centers (NOC) and network nodes. Depending on the readiness and availability of equipment and operators, the establishment of an interoperability network can occur in a relatively short period of time. This does not necessarily account for the power requirements of either the NOC or the network nodes.

The viability of implementing a communications network depends heavily on the availability of power to the network equipment. In many cases, where establishment of such a communications network is needed, power for the network equipment must be delivered from sources other than a commercial power grid. The mobility, readiness, and reliability of the selected electrical power source(s) are as equally important as the network equipment itself.

## **B. RESEARCH OBJECTIVES**

1. Provide an overview of the electrical power supply solutions that are currently available and emerging as possible solutions for application in powering communication network equipment.

2. Provide a comparative analysis of the candidate solutions based on network equipment requirements and candidate solution attributes.

3. Provide a summary of methodologies and practices for monitoring and managing network equipment power sources.

## **C. ORGANIZATION**

This thesis is divided into eleven chapters. An overview of the thesis and its uses and benefits are included in this chapter.

Chapter II describes the overarching system that remote network nodes and their power systems are a part of. It is in this chapter that general considerations about an interoperability network and some of the requirements for achieving an interoperability network are made. It is from

the general definition of an interoperability network that remote network node requirements are derived.

Conventional electric generators are discussed in Chapter III. In Chapter III, a brief overview of conventionally fueled motor operation is given in addition to the advantages and disadvantages of using electrical generators powered from such motors.

Chapter IV focuses on wind powered generators as a candidate for powering network nodes in remote locations. A discussion on the history and development of wind power is coupled with the advantages and disadvantages of using wind generators.

Chapter V discusses the use of solar energy for use in an interoperability network. An overview of photovoltaic theory and technologies is included in this chapter. Implementation pros and cons specific to incorporation in a remote node application are also included in Chapter V.

Utilization of the thermoelectric effect in the form of a thermoelectric generator is considered as a candidate power source in Chapter VI. A discussion of the thermoelectric effect and how it is applied to thermoelectric generator design is included in this chapter. Additionally, expected benefits and drawbacks to using thermoelectric technologies are also described within.

Chapter VII discusses an energy storage/generation device, the fuel cell. Discussion surrounding the use of a fuel cell as a power source for an interoperability network is devoted to this chapter solely because of its potential to act not only in a storage capacity but also as an



autonomous power source for remote node applications. The gains and faults of these technologies are also included in Chapter VII.

Chapter VIII is dedicated to energy storage devices. It is within this chapter that numerous methods of storing energy and using stored energy are evaluated. The focused energy storage device is the secondary battery. Variations of the secondary battery and each of their strengths and weaknesses are examined in Chapter VII.

An examination of hybrid power solutions is contained in Chapter IX. After discussing the various power supply candidates in the previous chapters, Chapter IX highlights some hybrid combinations of those candidates. The advantages and disadvantages of using the different combinations are examined, as well as the reasons for considering a hybrid power solution for power remote nodes.

Chapter X is devoted to a discussion on the monitoring and management of power systems associated with remote network nodes. A broad overview of current standards for remotely monitoring network components is discussed. Additionally, the consequences of such technologies when applied to power systems are exposed.

Closure of the research, recommendations, and suggestions for future work are included within Chapter XI. This chapter highlights the heightened benefits of incorporating hybrid power system solutions as an overall solution to powering interoperability network nodes positioned at distant locations.

#### **D. SCOPE AND INTENDED USE**

The primary intent of this thesis is to provide a broad overview of the potential tools and technologies that could be used in developing a means to power interoperability network nodes in remote locations. This thesis aims to discover current and emerging technologies that surround the issue of supplying electrical power to remote node equipment. Specific power system selection is not covered in this study. Such decisions should be reserved to situations where more precise requirements are known. This research does provide the background needed for making those decisions once specifics about a particular application are known.

#### **E. EXPECTED BENEFITS**

The results of the research conducted for this thesis can be used as a baseline tool to aid in the design of an interoperability network. Most significantly, this thesis can contribute to the design of the power systems used in the remote locations of the network. Through the use of the research contained within this thesis work, situational specifics can be considered in conjunction with the broader concepts to arrive at answers to needed power system solutions.

THIS PAGE INTENTIONALLY LEFT BLANK

## II. SYSTEM SPECIFICATIONS

### A. BACKGROUND

The current practice for supplying electrical power to deployed NOCs and node equipment is primarily through commercial power grids and/or gas/diesel electric generators. Even though public power services are often optimal in terms of cost and convenience, alternative methods are often necessary. Dependence on the availability of commercial power service is mostly undesirable due to the circumstances that surround the need for the types of communications networks discussed in this thesis. These circumstances can be demonstrated by two general scenarios that could be applied in either a civil or military application. The first is in the case of a natural disaster or military strike that has disrupted the grid power system. Because grid systems are generally centralized, a failure in one location will result in system-wide failures. The other scenario is the need to provide power to a remote location that does not have access to a grid power system. In either case, the solution is an off-grid power solution. In most situations to date, the alternative has been gas/diesel generators.

Commercial generators are often overkill in terms of power output when compared to the needs of a remote telecommunications node. While they are not necessarily the most efficient solution, they are easily implemented and subsequently the use of gas/diesel electric generators does often fill the requirement gap; however, the advantages and

disadvantages of conventional fuel generators raises a need to consider alternative methods for fulfilling the power needs of these networks. The advantages and disadvantages of gas/diesel generators are examined in Chapter III.

It is worth noting that many of the loads that would be utilized at a remote telecommunications node are in fact DC loads. However, they all have different voltage requirements and come equipped with appropriate AC adapters. This makes it easier to develop a system that adopts U.S. conventions for AC loads. It also allows for the ability to power future loads that may not have been considered in initial design.

#### **1. Interoperability Network**

An interoperability network is a network system designed to support the interoperability of dissimilar communication systems through an extension of the same technologies and principles that enable the internetworking of the Internet. Incompatible communications equipment began to capture government and public attention in 1995 after the bombing in Oklahoma City. An outcry to resolve the problem followed the terrorist attacks of September 11, 2001. An interoperability network strives to become the solution to communications and compatibility.

In order to ensure first responders and government agencies are capable to communicate directly, an interoperability network must meet several objectives. Some of those objectives include, but are limited to the following:

- The network must be readily available.
- Network coverage must be everywhere.
- Network is scalable.
- Network is manageable and maintainable.

Meeting such objectives can be extremely difficult and it is in many of these requirements that the infrastructure of an interoperability network must exceed those of the Internet. To best meet the objectives, many interoperability networks around the U.S. and the world share the following features:

- IP-Based Network
- Completely distributed architecture
- Support all radio frequency bands
- Mobile, or deployable, network nodes
- Highly reliable systems
- Redundant systems

The consideration and implementation of interoperability network objectives and features affects the end product in every manner from selection and design, to personnel manning and training, to implementation practicality and scope.

Power delivery and management is among the design and implementation issues that must be considered for an interoperability network. During time of dependence upon an interoperability network, the role that the power systems play will directly influence the operation and effectiveness of all the interoperability network objectives.

## **2. Remote Network Nodes**

A network objective of total coverage begs that some network nodes possess the capability to be stationed in remote locations. For the purpose of the discussions in this thesis, remote is considered any area that is not currently or readily serviced by public and/or private services. Most concerned with the topics of this thesis is the availability of electrical power from a commercial power grid or other pre-established power supply.

Many different standards and technologies are available in the field of networking. For the purposes of this thesis, we are concerned with the ability to create new routable networks and/or extend the reach of the existing fixed Internet. An appropriate area of technology for this application is within the IEEE 802.16 standard. One common industry technology based upon this standard is WiMAX (Worldwide Interoperability for Microwave Access).

Technologies based on IEEE 802.16 standards are the methods most commonly adopted for implementation in interoperability networks. The advantages of using IEEE 802.16 standards and equipment supports the objectives of an interoperability network, which include high capacity, quality of service, flexible architecture, user mobility, scalability, and cost effectiveness (Ahson and Ilyas 2007).

This thesis will consider technology based on the IEEE 802.16 standard for equipping remote interoperability network nodes. More specifically, remote network nodes are primarily comprised of the IEEE 802.16 based hardware required to support the network in terms of user access and

data transfer to and from locations distant from network headquarters, requiring an autonomous source of power.

## **B. POWER REQUIREMENTS**

Providing electrical power to a remote network node requires that all network equipment associated with the node can, when needed, be supplied with electrical power at the proper ratings. The specific equipment incorporated within a network node can vary depending on the specific needs for the node and network area. At a minimum, a network node will consist of an access point. Needs that are more elaborate might entail the use of routing equipment, a bridge, or even a computing device (such as a laptop computer). Considering the first responder needs to a disaster area can demonstrate a rudimentary example of this. Within this situation there will be various units spread out over the affected area. There will also be a base of operations (NOC). By utilizing IEEE 802.16 equipment to create a remote node, a viable network can be established in the vicinity of the disaster area. Ultimately, the power supply system must be capable of providing the proper voltage and enough power for the node hardware. The actual equipment selected for use will define these requirements.

## **C. SYSTEM AVAILABILITY**

In the case of a first responder or military application type of network, the requirements will be heavily impacted by factors such as the availability of the network. In a high availability network, the network must be present and operating at all times. In reality, this is not statistically possible; however, we can take steps to



maximize system availability. Fundamentally, operational availability is the relationship between system uptime and downtime.

$$A_o = \frac{Uptime}{Uptime + Downtime}$$

Many factors can affect the operational availability of a system. Some of these factors are inherent in the system, such as average time of failure for system components and subsequently the average time it takes to repair those failures. When designing a high availability system, the goal is to reduce downtime to such a point that the availability requirements are met. Downtime can be reduced in a system by eliminating single points of failure and by providing seamless system transition between system components if failures do occur.

One way to increase availability is by introducing redundancy into the system. Properly implemented, redundancy helps to address single point failures and improves reliable system. For example, by incorporating multiple power sources, continued operations are ensured even in the event one fails. A system in which power sources are operating in parallel provides continuous power regardless of the state of individual power systems, as does having a mechanism in place to minimize/prevent failures. Half of combating system faults and failures over time is proper system maintenance. The other half is addressed by developing measures to monitor system health, detect faults, and subsequently monitor those qualities. This is a very important aspect to operational availability and is further discussed in Chapter X.

### **III. CONVENTIONAL ELECTRIC GENERATORS**

Conventional electric generators are heavily utilized as power sources in temporary and ad-hoc systems as well as remote location applications. Gasoline and diesel fueled engines are among the most developed power technologies available today. Their high use as electric generators extends from the abundance of other utilities using conventionally fueled motors.

#### **A. GENERAL**

Nearly all portable electric generators using a liquid fuel use petrol (gasoline) or diesel fuel. And therefore, operate on the theory of internal combustion.

##### **1. Internal Combustion**

The concept of an internal combustion engine simply revolves around the concept that when a fuel combusts, or ignites, the gases produced expand in temperature and pressure. Temperature and pressure energy then exerts force on movable parts to cause mechanical work.

The thermodynamic cycle of a combustion engine comprises of four stages, which are shown in Figure 1 and described below:

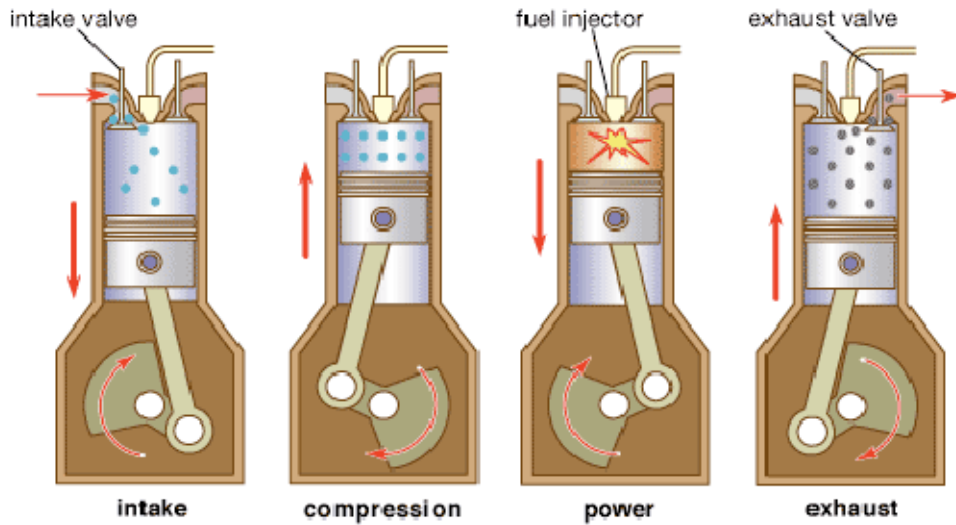

Figure 1. General Illustration of the Thermodynamic cycle of an Internal Combustion Engine. (From Britannica Student Encyclopaedia)

- 1) Intake/Induction - Pressure within the combustion chamber is reduced. This is typically accomplished by expanding the volume of the combustion chamber. The combustible fuel is then introduced into the combustion chamber.
- 2) Compression - The fuel is compressed; usually done by reducing the volume of the compression chamber.
- 3) Power - At the peak of the compression process, the fuel is ignited with a spark, heat, pressure, or combination of the elements. Once ignited, the fuel expands in the form of gases with high temperature and pressure exerting force to do mechanical work.
- 4) Exhaust - The combustion byproducts are expelled from the combustion chamber. The reduction of volume in the combustion chamber, again, is typically used to accomplish this.

In most internal combustion engines, the combustion chamber is comprised of a fixed cylinder with a movable piston like that illustrated in Figure 1. As you could imagine, the four stages of a combustion engine would characterize the operation of combustion engines.

There are, however, variations of combustion engine operation, and those are four-stroke engines, two-stroke engines, and others, like the Wankel rotary engine. All internal combustion engines operate on the same thermodynamic cycle. These variations are derivatives of how each of the four stages occurs. The significant difference in terms of the thermodynamics between petrol and diesel fuel engines is the fuel ignition method. Diesel engines use compression ignition, whereas gasoline engines use a spark ignition. Properties of diesel fuel allow for ignition of the fuel at designed high-end combustion chamber pressures. This is not possible with petrol-fuels, and thus, a spark ignition is required.

## **2. Petrol versus Diesel**

In comparing petrol and diesel type internal combustion engines, it is notable that diesel is used to power nearly 80 percent of all ships, trucks, trains, and buses. This is due to the fact that diesel fueled engines are more efficient than gasoline engines. Because of its density, diesel contains approximately 15 percent more energy by volume than gasoline. The properties of diesel and the design of diesel engines yield a margin close to 40 percent more efficient in favor of diesel.

Engine size and weight are affected by the selection of fuel type. Diesel engines are typically larger and heavier than gasoline engines of comparable output. This is attributed to the lower output characteristics of diesel engines. For that reason, smaller sized vehicles, such as cars, most often utilize petrol engines over diesel. Similarly, gasoline portable, backup electric generators will often be selected for use because of the reduction in size and weight.

A cost comparison between gasoline and diesel generators requires examination beyond the off-the-shelf price tags. Initial purchase price of comparable output generators will usually favor the gasoline model. Diesel generators are usually made of more expensive parts that are made to last longer. However, when repairs are needed, repairs to a diesel engine will likely cost more. The argument here is that gasoline engines are designed to operate at higher speeds, and thus wear much more quickly. A determination of lifetime cost would require some idea of expected usage. In most cases, where usage is minimal or periodic, cost savings are found in a gasoline-fueled option. Diesels realize their cost savings over petrol in scenarios of long duration, high usage.

## **B. ADVANTAGES**

Advantages to conventional fuel electric generators can be found in their simplicity and maturity. Because they are so predominant and have been available for such an extended amount of time, conventional fuel electric generators can be purchased at relatively low cost and in a vast range of

output capability. They can be found in pretty much any form of portability and sustainability to suit the needs of any particular application.

### **C. DISADVANTAGES**

Alternatives to conventional fueled engines have been of great interest, and that interest is continuing to grow. The prime motive to seeking other energy methods include an ever growing cost for fossil fuels, environmental effects of combustion engines, and dependency upon other nations for fuel. Those allude to a shift in developmental focus away from combustion engine technologies and toward other alternative energy technologies. There are other disadvantages to using combustion engine electric generators, particularly for powering remote network nodes. Two of the major drawbacks are refueling requirements and maintenance requirements. Combustion engines, petrol and diesel alike, require a good deal of maintenance to ensure proper and reliable operation. And an abundant fuel supply or frequent refueling operations are necessary when using these as a primary power source. The disadvantages of conventional fueled electric generators must be a consideration in the design and implementation of an interoperability network involving remote location nodes.

THIS PAGE INTENTIONALLY LEFT BLANK

## IV. WIND POWERED GENERATORS

### A. BACKGROUND

A wind-powered generator has the fundamental purpose of taking the kinetic energy of the wind and converting it into electricity. This is done through the use of a rotor containing two or more blades, which are mechanically coupled to an electrical generator (Ahmed et al. 2009). Although the power of the wind has been harnessed for centuries, this type of application is relatively new.

Some of the first uses of wind were accomplished by using sails to harness the power in order to move boats. Wind was later used in some of the first vertical-axis type windmills in order to grind grain (Ozgener 2006). Figure 3 is an example of an ancient Persian turbine used to do just that. Probably the most iconic of all windmills is that of the recognizable Dutch windmill (Figure 2). The Dutch windmill is one of the first commonly used horizontal-axis windmill. These windmills were used to grind flour and came about in the late 1100s.





Figure 2. Dutch Windmill (From Kreith 2007)

It was not until the late 1800s and early 1900s that the wind turbine really started to become popularized. This was before the electrical infrastructure of the country became more developed. Many farmers used wind turbines to power radios, washing machines, lights, etc. This gradually died out when the Rural Electrification Administration was developed in the 1930s, which helped to make cheap electricity available to many areas of the country (Ozgener 2006).

Just as it is with other types of renewable energies, the environmental and geographical factors that help to create the energy are factors that affect the system as well. It is important to consider these factors when picking a site or designing the characteristics of the system to be used.

Wind power is actually an indirect form of solar power. This is because wind is actually a part of the convection cycle in the atmosphere that is caused by the heating and cooling related to sunlight (EERE). Due to the positional

relationship between the Earth and the sun, as well as the rotation of the Earth, the sun's radiation unevenly heats the surface and atmosphere of the Earth. This is due to two main factors, one relating to latitude on the Earth and the other due to surface properties.

With respect to the latitude of the Earth, the Polar Regions receive less solar energy than the equatorial regions. This causes the central latitudes to be warmer and contribute to the convection cycle. The surface factor has to do with whether or not the location is water or land. Landmasses tend to heat up and cool down faster than the oceans or other bodies of water. This also impacts the convection cycle occurring within the atmosphere.

Not only do these factors cause wind to occur, but also the cycle causes variations in the wind throughout the day and is known as the diurnal cycle. Solar heating causes warm air to rise and this warm air is subsequently replaced with cooler air. This mixing is the wind that we feel and is usually strongest during the middle of the day. As the day cools into night the air closest to the ground slows down. This affects the design of a wind turbine system specifically with respect to the height of the turbine (EERE). During the day a shorter turbine will produce more energy than a taller turbine and vice versa.

The time of year will also cause variations in wind. This is due to the differences in the solar radiation the Earth receives as it rotates around the sun. The changes in solar radiation are discussed in more detail in Chapter V.

Site location also has an important role in system design. This is in part due to variations in wind across

the globe. Subsequently, depending on the size and location of the country in question, you may or may not have any option. However, at any given location there is also a terrain factor, and this includes anything that could be considered an obstacle.

An obstacle is anything that could block or alter the direction and intensity of the wind. These could be factors such as hills, trees or even buildings. This generally affects system design with respect to turbine height. Overcoming such obstacles is done through the use of a tower in order to access the best wind resources available. The rule of thumb for tower height is to achieve a turbine height of approximately 10 meters above any obstacles that are within 100 meters (AWEA 2001).

## **B. TYPES**

There are two general classifications of wind turbines. The first type is known as the Vertical-Axis Wind Turbine (VAWT). The VAWT, as seen in Figure 3, was the first type of wind turbine developed for use and is still used today, but is much less common. The other type is known as the Horizontal-Axis Wind Turbine (HAWT) (Kreith 2007). This is the class of wind turbine that most people would visualize when thinking of wind power and is the predominantly used style throughout the world (Figure 4).

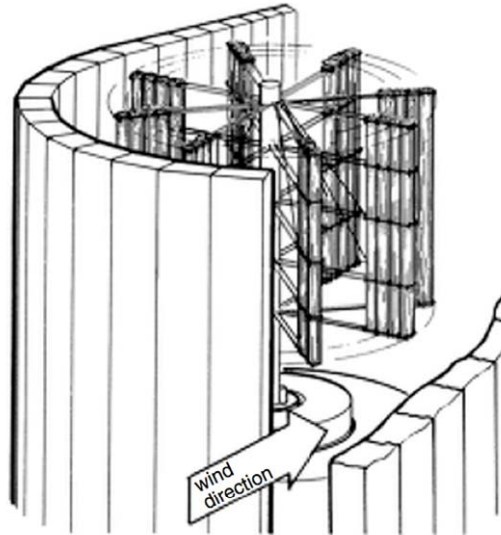

Figure 3. Ancient Persian VAWT (From Kreith 2007)



Figure 4. Multi-Blade HAWT (From Kreith 2007)

Within each of these overall classifications of wind turbines there are also two basic types of blades that can be used. The first type of blade operates on the aerodynamic principle of drag. This is the more traditional type of blade and can be made in a variety of shapes, such as flat or curved. This type of blade harnesses wind power by the sheer force of being pushed by the wind. The other

type of blade operates on the aerodynamic principle of lift and is the basis of most modern blades (Ozgener 2006). These blades can be thought of like the wings of an airplane. In reality both drag and lift effects are at play but the overall effect is a thrust that pulls the blade through the air.

The most advanced aerodynamic technologies have helped to increase the efficiency of wind turbines. Blades that harness lift principles have definitely increased efficiency over drag-style blades. However, while modern turbines have achieved efficiencies of on average 40-45 percent, wind turbine technology has a theoretical limit of a wind energy conversion efficiency of 59.3 percent, which is due to the Betz Criteria (Ozgener 2006). Betz' Law shows that not all the energy of wind passing by a certain point can be utilized. This limit is independent of any additional inefficiency created due to material or engineering obstacles. Figure 5 shows a comparison of various turbine types with respect to efficiency.

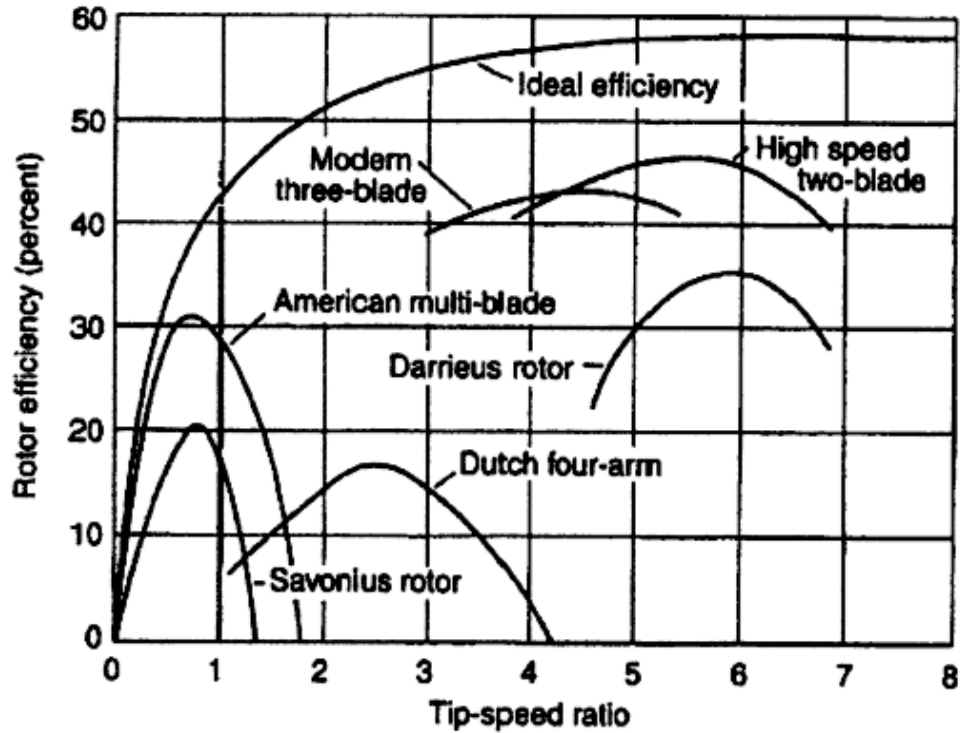

Figure 5. Power Coefficient vs. TSR for Various Types of Wind Turbines (From Ahmed et al. 2009)

With all these factors considered, there are four general electrical power generation applications in which wind power is employed. These categories are (1) small, non-grid connected, (2) small, grid connected, (3) large, non-grid connected, and (4) large, grid connected (Grigsby 2007).

If a system is considered to be grid connected, the system is connected to the utility grid. At present date, grid connected systems are not very common. This is mainly due to economic factors. In order for a grid-connected system to be economically justifiable, it needs to be able to have a lower cost per kilowatt than the utility grid provides (Grigsby 2007). With the current resources of the

utility companies and the cost of fossil fuels, both small and large-scale grid connected systems just do not pay off for the average user.

It would then follow that the majority of wind power systems are non-grid connected. Perhaps not in the sense of overall power output, since many countries use wind power to help supply the electrical needs of the country, but in the sense of individual uses. A non-grid connected system is generally used for the purpose of providing energy to an area not serviced by commercial utilities. A couple examples of this could be a rural home, remote transmitter or antenna, or on a larger scale it could be a remote village in a third world country. The size, whether it is large or small, is not a hard and fast rule, but small would generally be considered less than 100 kilowatts (U.S. DoE 2008). Large would be considered anything on a utility scale.

### **C. EQUIPMENT**

A wind power system only requires a few components to function. However, there are numerous options to choose from and selecting the appropriate equipment is vital. In order to determine which products are appropriate, it is important to do a load and site analysis. By knowing how much power will be required to operate all of the desired loads, as well as the available wind resources, it helps to create a more economic and efficient system.

The main component of a wind power system is the wind turbine. This is the piece of equipment that harnesses the kinetic energy of the wind and converts it to an electrical

output. Turbines come in a multitude of sizes and have power output anywhere from a few watts to the megawatts range. It is also important to understand the difference between a turbine's rated power and what actual output is likely to be. Different companies base turbine ratings upon different wind resource assumptions. For example, a turbine's power output may be based on a wind speed of 25 mph. If the site being considered for a wind power system only receives an average wind speed of 15 mph, then it will obviously not generate the full rated power. In addition, it is unlikely that the site will constantly have a 15 mph wind through the area. These types of factors are important when determining required turbine size and will even play an important role in other areas such as storage system size.

The second most important part of the system is the tower. There are two general types of towers that can be used. There are self-supporting types of towers and guyed towers. Guyed towers are less expensive than self-supporting towers and are therefore more common. A guyed tower is usually made up of some type of metal framework, which is anchored to the Earth and supported by guy cables. The size of the tower is important to maximize energy output of the turbine. As previously discussed, it is important to be higher than any obstacles in the vicinity. Even if there are no obstacles around, a site analysis will help to determine the optimum height by weighing the cost of increased tower height against the increase in power achieved.



Since it is unlikely that a given wind turbine will produce the necessary power for the system load at every moment the system needs it, there are additional components required. If the system were producing more energy than required, it would be advantageous to be able to save that excess energy for later use. At the same time, it is important to be able to power the system load if there is insufficient wind to generate that power. The solution is having an energy storage device with the accompanying equipment to convert and control current to and from these devices.

There are many different ways to store the energy output of a wind turbine. However, the most common is through the use of a secondary battery. Some batteries have the ability to charge and discharge around 80 percent of their capacity, hundreds of times (Yang et al. 2007). Secondary batteries are further discussed in Chapter VIII. In the case of a wind turbine, the output is AC and batteries take in DC. This requires an intermediate piece of equipment known as a charge controller.

The charge controller used in a wind system contains rectifiers, which convert the AC output from the generator into a useable DC input for the batteries. In addition to this, the charge controller also controls battery charging. This is done in order to prevent damaging the batteries via overcharging.

The final piece of equipment necessary for a wind power system is an inverter. This is required in order to convert DC output from the storage battery into a usable AC input for system loads. There are multiple types of inverters,

each with different applications. Chapter V, Photovoltaic Systems, discusses the types of inverters in more depth.

#### **D. FEASIBILITY**

There are many characteristics of a wind turbine system that make this technology a viable solution. One of the greatest advantages is that this type of power comes from a renewable energy source. This means the elimination of costs associated with the time and resources needed to monitor and refuel other sources of power. Being a renewable energy also provides the advantages of being a clean fuel source and a domestic fuel source.

Another advantage of wind turbines is that they generally require less maintenance than diesel generators. When considering maintenance requirements and costs it is important to differentiate between preventative and corrective maintenance. While some of the older wind turbine technologies can require a fair amount of preventative maintenance, it is still less than the amount of preventative maintenance required on diesel generators.

Some of the newer turbine technologies that utilize permanent magnet systems, rather than slip rings and brushes, require little to no maintenance. When you start to consider corrective maintenance, the costs can increase considerably for wind turbines when compared to the cost of the entire system. However, this is less true with smaller wind turbines because a major contributor to cost can be associated with obtaining a crane large enough to access failed components on a large turbine.

There are a couple of disadvantages to a wind power system, but these are generally less important when compared to the advantages. The biggest disadvantage of a wind energy system is the difference between when energy is harnessed versus when there is electrical demand from the system loads (EERE). Properly designing the system and ensuring there is an adequate battery storage system overcomes this disadvantage. This solution is one of the direct causes of another disadvantage and that is initial cost of the system. Not always, but in general, a wind power system has a larger initial investment than that of an equivalent fossil fueled generator. In a remote location the advantage of system autonomy is likely more important than system cost.

Once a wind system is operating, it is important to assess its performance. As discussed in Chapter II, availability is of the utmost importance in a first responder/military application. A few parameters of importance in a wind turbine based system are factors such as power output, turbine speed, and wind speed. Being able to assess these values instantaneously as well as an average over time will help evaluate its operation. This can be accomplished through a comparison of those parameters and load usage analysis. Some of these qualities are discussed in more detail in the implementation section of Chapter X.

#### **E. CONCLUSION**

Whether or not a wind energy system is an adequate solution really depends on the needs of loads and the availability of resources at the site. Average resource availability at a good site breaks down to generating rated

output approximately 10 percent of the time, no output 10 percent of the time and some intermediate output for the remaining 80 percent (Grigsby 2007). There are many applications where a stand-alone wind energy system could be sufficient. However, if the desire is to create a general-purpose system that will provide high reliability in all scenarios, then this type of solution will need to be paired with another energy source in a hybrid system.

THIS PAGE INTENTIONALLY LEFT BLANK

## V. PHOTOVOLTAIC SYSTEMS

### A. BACKGROUND

Photovoltaic (PV) systems are more commonly known as solar energy systems. This type of renewable energy source is one of the most commonly used and well-developed technologies. PV systems work by directly converting sunlight into electricity without any intervening heat engine (Kreith 2007). This occurs through the process known as photoelectric effect.

The French physicist Edmond Becquerel first described this process in 1839. Heinrich Hertz later studied it in the 1870s when the first Selenium PV cells were created; they only operated at a near 1 percent efficiency. It was not until the 1940s and 1950s, when the Czochralski process was developed, that the production of very pure crystalline silicon was made possible. Bell Laboratories started work on silicon PV cells and, in 1958, the U.S. space program became highly interested in the technology. Today, nearly all satellites are powered by PV systems (Aabakken 2006).

All solar cells are made from semiconductor materials. The most common in use today is silicon. This is necessary in order for the PV effect to occur, since the physics of the process is very similar to that which occurs in a P-N junction diode as shown in Figure 6. In order for electricity to be generated, a photon must have energy greater than or equal to the bandgap of the semiconductor material (Kreith 2007). This in turn will create an electron-hole pair creating current; and any extra energy is

wasted as heat energy. This bandgap property of semiconductor material is also what determines the theoretical limit of efficiency of a solar cell. This efficiency always comes with a price and typically the more efficient a material is, the greater the cost is for the solar cells.

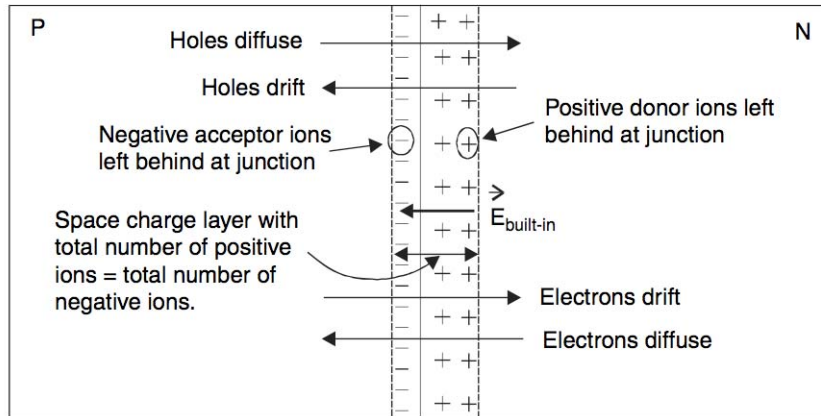

Figure 6. P-N Junction Showing Electron and Hole Drift and Diffusion (From Kreith 2007)

The relationship between cost and efficiency is important with respect to the design of a PV system. The only factor more important than this relationship has to do with the availability of solar resources. Solar resources can also be thought of as solar radiation, or the electromagnetic radiation from the sun. The amount of solar radiation available at any given site is dependent on numerous factors such as weather, time of day, time of year and physical location. Without sufficient resources at any given location, a PV system is useless.

The impact of weather on solar power is a pretty obvious one. When inclement weather is present, there is usually less sunlight. Today there is generally enough

historical data and modern technology available that an area can be analyzed for suitability. Sometimes even if the average weather is not ideal for solar power, it can help determine better-suited technologies to be used in the system. One example of this would be the decision to use solar arrays that track the sun or not. It is actually less energy efficient to use tracking type of technology in an area that experiences frequent cloud cover.

Time of day is another factor that is pretty self-explanatory. If it is daytime, there is obviously more solar radiation available than during the night. It is also a factor that we have no control over, but it is still important to understand the impact when creating a PV system. The majority of solar power is generated during the peak of the day, when the sun is overhead. During the morning and evening, the generated power is significantly less due to the angle at which the sunlight is hitting the Earth. It is important to understand this in order to properly determine the number of solar cells and battery storage needed in order to meet the needs of the load.

Time of year is another factor that we have no control over, but plays an important role in availability of solar resources. This is due to the distance of the Earth from the Sun and the tilt of the Earth on its axis. Since the orbit of the Earth is elliptical, this means that there are times of the year when the Earth is closer to the Sun than other times of the year. When the Earth is closer, it receives more solar radiation. However, depending upon what hemisphere you are in, the amount of solar energy you receive can vary. This is due to the tilt of the Earth.



The tilt of Earth has a much more significant impact on solar radiation present than how close the Earth is to the Sun. When the Earth is at its closest point to the Sun, the Southern hemisphere is tilted towards the Sun. This is when it is winter for the Northern hemisphere and summer for the Southern. When the Earth is at its furthest point, the opposite is true. So when the Earth as a whole is closer to the sun and receiving more solar radiation, places like the United States are actually receiving less solar radiation than at other times of the year.

The last main factor in the amount of solar resources present is location. Location can make a huge difference in the amount of solar radiation available and of all the factors is the only one that we really have any control over. The ability to change locations may even have limited options depending on what environment or country you are in. Areas closer to the equator, or middle latitudes, receive more solar energy than those at higher latitudes. We see this in a country such as the United States that we have a lot of different options. In general the best locations for solar energy are in the southern portions of the country.

## **B. TYPES**

As previously mentioned, there are numerous types of solar cell materials available. The main differences between materials are their ability to efficiently convert energy, and the cost associated with that efficiency.

The most common material used for the creation of solar cells is silicon. Within the area of silicon there are four subcategories of cells. These are mono-crystalline silicon,

poly-crystalline silicon, thin silicon, and amorphous silicon cells. Just like anything else, these different variations come with advantages and disadvantages. There are also a handful of non-silicon based cells. The main ones being gallium arsenide cells, copper indium (gallium) (di)selenide cells, and cadmium telluride cells (Grigsby 2007). Following the various cell descriptions is Figure 8, which compares the efficiencies of different cell technologies.

### **1. Mono-Crystalline**

Mono-crystalline cells are also known as single crystal cells. These are the most common solar cells in use. A mono-crystalline cell is made from a cut of silicon grown from a single crystal, typically referred to as a wafer. This process takes more time than other fabrication processes but the resultant solar cells have a better efficiency in converting solar energy to electricity (Grigsby 2007).

### **2. Poly-Crystalline**

Poly-crystalline cells are also known as multi-crystalline cells. This type of cell is created by pouring molten silicon into a mold and controlling the rate at which it cools. Unlike single crystal cells, this process allows for the growing of rectangular silicon. This process creates less waste since once cells are cut from the silicon the wafers are already in the appropriate size and shape for the modules. These types of cells are cheaper to fabricate than the single crystal cells but are also less efficient. The easiest way to tell the difference between a poly-

crystalline cell and mono-crystalline cell is by looking at them. A poly-crystalline cell appears speckled while a mono-crystalline cell looks very uniform in appearance (Grigsby 2007).

### **3. Thin Silicon**

Thin silicon cells are also known as buried contact cells. In most types of PV cells, current flows from the front to the back. The thin silicon cell differs in that current flows parallel to the surface along multiple conduction paths. This is due to the way these cells are constructed. Putting a dielectric layer on top of an insulating substrate, then putting alternating layers of P-type and N-type silicon on top creates a thin silicon cell. Multiple channels are then cut using layers and placing a conducting path within the channel. This technique has some great advantages. It has the ability to create flexible panels and uses less silicon, so it has the potential to reduce manufacturing costs in the future. However, this technology is relatively new so the cells are not as efficient and watt-for-watt they are more expensive than their counterparts (Grigsby 2007).

### **4. Amorphous Silicon**

Amorphous silicon is very different than the other types of silicon cells in that amorphous silicon does not have a crystal structure. The main advantage of this type of cell has to do with the production technique. Amorphous silicon can be easily put down onto large areas as well as made into thin film styles. This process can also be done at relatively low temperatures, which allows for the silicon

to be put onto plastics. Due to the atomic structure of amorphous silicon, the efficiency is greatly reduced. However, there are techniques to introduce hydrogen into the material, which creates some interesting properties.

The introduction of hydrogen passivates the material, which causes the absorption constant of the material to increase. Due to the nature of how these types of cells are produced, it has also led to the manufacturing of multi-layer cells. These cells are constructed using multiple types of amorphous alloys of silicon. By creating a cell, where each layer has a different bandgap, it increases the overall ability of a cell to utilize solar radiation and subsequently increase its efficiency (Grigsby 2007).

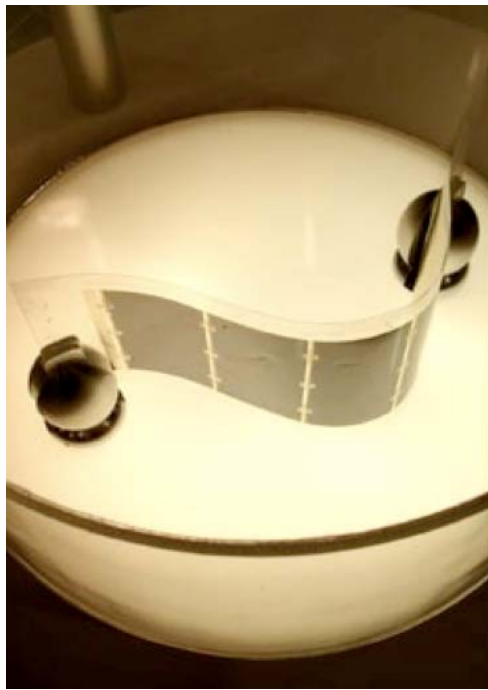

Figure 7. Amorphous (Thin) PV Film (From U.S. DoE 2007)

## **5. Gallium Arsenide**

Gallium arsenide (GaAs) cells are a high-cost, high-efficiency type of solar cell. One of the main advantages of this type of material is that it has a high ability to absorb sunlight. GaAs can absorb sunlight with material only a few microns thick, whereas silicon requires 100+ microns. GaAs is also a material that is relatively unaffected by severe temperatures and radiation exposure. These qualities make GaAs an excellent material for thin layer and multi-layer type solar cells. The main drawback to this type of material is cost (Grigsby 2007).

## **6. Other**

The last two type of solar cell material to be discussed are Copper Indium Gallium (Di)Selenide (CIGS) cells and cadmium telluride cells. These materials are mainly used in the construction of thin film type cells. They are both cheaper alternatives to crystalline silicon and GaAs cells. They are in many ways similar to the amorphous silicon cells but currently achieve slightly higher efficiency (Grigsby 2007).

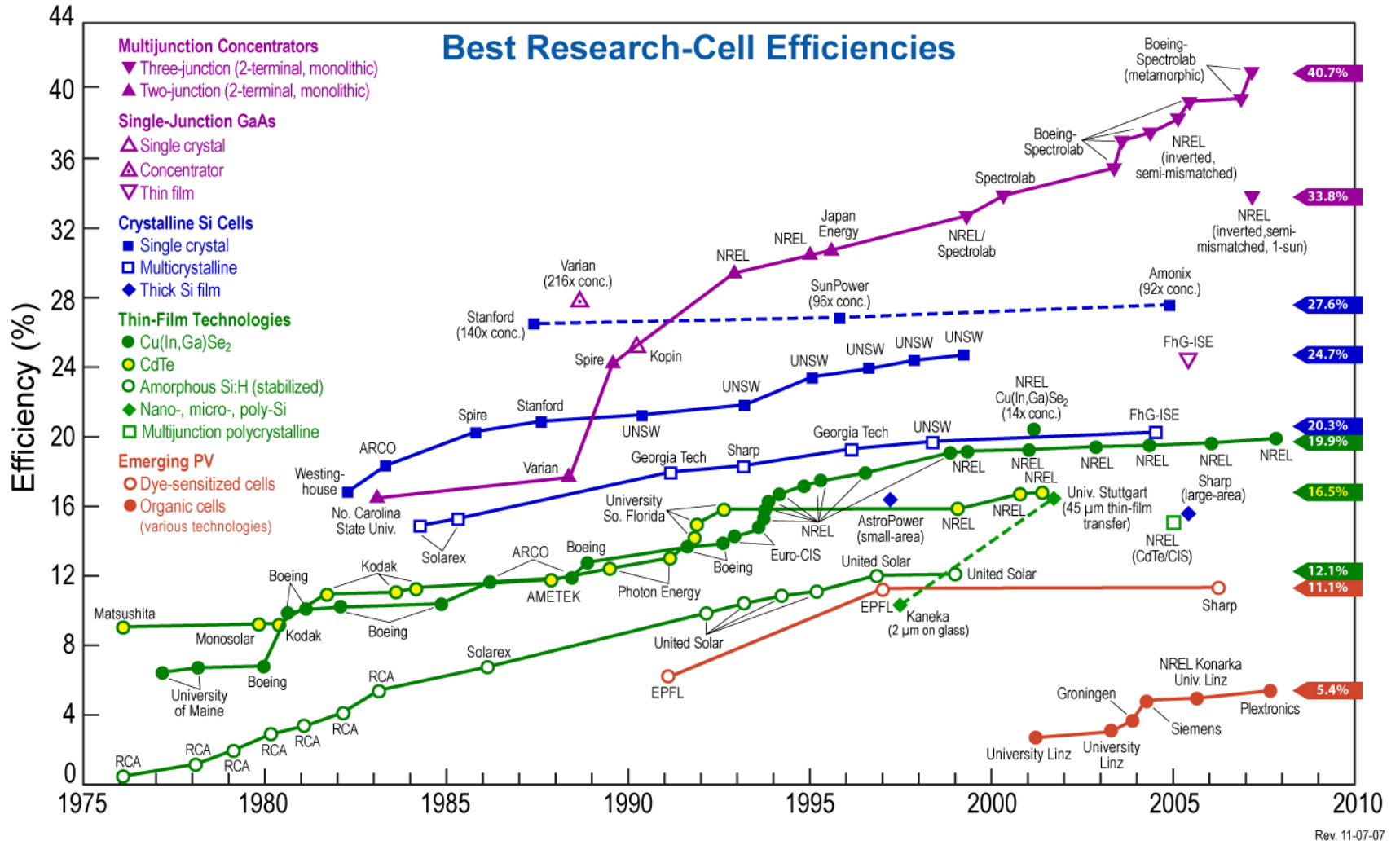

Figure 8. PV Cell Efficiencies (From Kreith 2007)

### C. EQUIPMENT

In order to effectively harness energy from the sun, multiple pieces of equipment are required. It is important to properly identify the needs of the system because this can significantly impact what components the system needs.

The most basic component of a PV system is the solar cell. A single solar cell by itself is insufficient for any realistic load. However, cells are put together in series and/or parallel in order to produce solar modules, panels, and arrays as seen in Figure 9. Even after determining the type of cell and size of module to be used, there are still other important items necessary to complete a PV system.

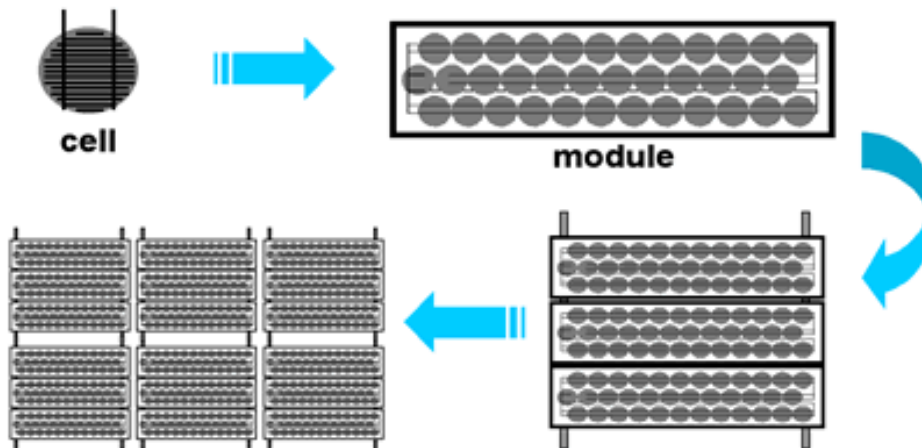

Figure 9. PV Cell, Module, Panel and Array (From Florida Solar Energy Center)

The output from solar panels is in the form of DC current. There are simple DC loads that would operate when directly connected to the output of a solar panel. This is the most simplistic type of PV system and it will only operate when there is enough solar radiation present to

produce the required current. This does not provide enough reliability for most situations and many devices operate off of AC current. In order to meet these needs, a PV system also needs an inverter, charge controller, and energy storage device.

A sine wave inverter is the device used to convert DC power into AC power. There are two basic types of inverters, the true (pure) sine wave inverter and modified (square) sine wave inverter. A pure-sine wave inverter produces power as a smooth sine wave, which is similar to that obtained from the public grid. A modified-sine wave inverter produces power that is more of a choppy or square wave (Kreith 2007). The type of inverter required depends on what is required by the load. Most equipment will operate fine off of a modified-sine wave. However, there are specialized pieces of gear that need a pure-sine wave.

The last two pieces of equipment, the charge controller and storage battery, work hand in hand. The fundamental purpose of a charge controller is to control the rate at which current is put into or taken out of a battery. The selection of battery storage is heavily dependent on the needs of the load and system reliability requirements. These factors are critical in the design of a PV system.

#### **D. FEASIBILITY**

A PV system has many advantages that make it a very credible solution. Two of the biggest advantages are that there are no associated fuel costs and the solar panels are very low maintenance. With the newer thin film technologies it has also allowed for the development of more ruggedized



solar panels. This is a desirable quality when put into a first responder or military type of environment.

A simple PV system would not be a sufficient solution. When dealing with telecommunications equipment, it is very important to have a near 100 percent reliability (Kaldellis 2003). It would do no good to only have this type of equipment powered for a small portion of a day. It would be necessary to have battery storage in place to ensure operation through the night or during inclement weather. Even then this may not be able to meet the system requirements depending on the environment of the system location.

Once a PV system is operating, it is important to assess its performance. Just as discussed for wind power, there are parameters associated with a PV system that can help accomplish this. Mainly the attribute of concern will be power output, both instantaneously and averaged over time. This can be when compared with load usage analysis and even compared between various solar panels to assess system operation and performance. These qualities are discussed in more detail in the implementation section of Chapter X.

#### **E. CONCLUSION**

A basic PV system and battery storage system would be adequate in certain situations. If they were used in a location that receives sufficient solar radiation, it is likely that no additional energy sources would be needed. However, if the geographical and environmental conditions are not well suited, then the solar panels need to be

supplemented with another source of power. This would result in some type of hybrid power solution, which is likely the best option in order to ensure high reliability of the system.

THIS PAGE INTENTIONALLY LEFT BLANK

## **VI. THERMOELECTRIC GENERATORS**

### **A. GENERAL**

Thermoelectric generators are devices that convert heat into electrical power. The Seebeck effect is the principle by which thermoelectric generators (TEG), or thermogenerators, operate.

Current applications for TEGs are predominantly for powering remote telecommunication sites and loads. Notably, the United States Coast Guard utilizes TEGs for many of its Voice Distress Network sites along the Alaskan coastline. The space industry has played a significant role in the use of TEGs. Nearly all nuclear powered sources onboard satellites and spacecraft achieved their power conversion with TEGs. Other applications include navigation and signal lights, weather stations, and cathodic pipeline protection devices.

#### **1. Seebeck Effect**

The Seebeck effect, attributed to Thomas Seebeck, is the conversion of a temperature difference or temperature gradient into electricity. When two dissimilar metals or semiconductors are exposed to different temperatures, a voltage potential is created between the two. The voltage potential created is a function of the temperature difference and characteristics of the materials used. When the dissimilar metals (or semiconductors) are electrically connected, the voltage potential creates an electrical current.

## 2. Principles of Operation

Based on the theory of the Seebeck effect, modern TEGs utilize two semiconductor materials, a P-type and an N-type, which are electrically connected in series and thermally connected in parallel. As illustrated in Figure 10, heat is inputted to the hot junction of the thermal circuit and rejected from the cold junction. The result is a migration of electrons from hot to cold within the N-type material and hole-flow from hot to cold within the P-type material.

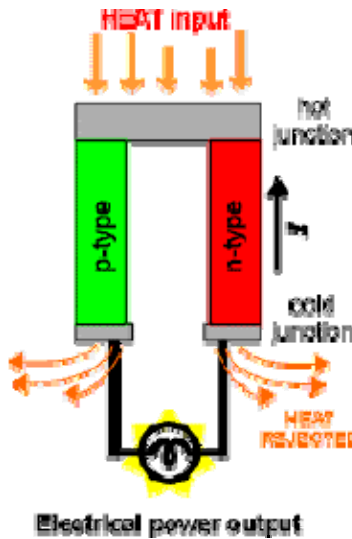

Figure 10. Basic Principle of Thermoelectric Conversion.  
(From Thermoelectrics.com)

In the absence of an electrical connection between the P-type and N-type materials, the result would be a voltage potential between the two at the cold junction. The electrical connection between the P-type and N-type materials (typically in the form a load), provides a path for electrons to flow from the cold junction of the N-type to the cold junction of the P-type material. Similarly, the electrical connection allows holes to flow from the cold junction of the P-type material to the cold junction of the

N-type material. The net result is the flow of electrical current through the load, thus supplying the load with electrical power.

### 3. Commercial Thermoelectric Generators

Thermoelectric generators are predominantly available commercially from two manufacturers. Teledyne Energy Systems, which is based out of the U.S., and Global Thermoelectric Inc., based out of Canada. Between these two major companies, there are more than 20 thermoelectric generator models available. Those models range in power output from as little as 10 watts to over 500 watts. The major commonality among the various models is that nearly all are designed to operate with either propane or natural gas as a fuel source. Table 1 provides a summary of those gas-fueled TEGs available for commercial purchase. However, there are some models designed for the use of liquid fuels, such as diesel.

Manufacturer	Basic Model	Nominal Wattage	Natural Voltage	Watts at 12 V DC	Watts at 24 V DC	Fuel (LPG) kg/d	Price <sup>a</sup> USD
Teledyne	2T1	10	4.8	8	8	0.73	2295
Teledyne	2T2	20	9.6	17	17	1.46	2995
Global	5030	30	2.5	24	24	1.50	2715 <sup>b</sup>
Teledyne	2T3	30	14.4	30	25	2.19	3420
Teledyne	2T4	40	19.2	36	36	2.91	4295
Global	TCELL50	50	3.5	40	40	2.90	2284
Teledyne	2T5	50	24	50	50	3.63	5075
Global	5060	60	6.7	54	54	2.90	5220
Teledyne	2T6	60	28.8	60	60	4.36	5975
Teledyne	2T7	70	33.6	68	68	5.09	6895
Teledyne	2T8	80	38.4	79	74	5.81	7800
Teledyne	2T9	90	43.2	90	89	6.54	8500
Global	5120	120	6.7	108	108	5.8	5481
Global	5220	220	15	220	176	14.2	8039
Global	8550	550	27	480	550	38.0	16443

<sup>a</sup> Prices are based upon manufacturers' published list prices. Prices are in U.S. dollars.

<sup>b</sup> Price includes a DC-DC convertor.

Table 1. Commercially Available Thermoelectric Generators (From Rowe 1995).

Today's TEGs are built for extended operating times and little maintenance requirements. Typical commercial TEGs can operate for nearly a year between servicing, and the servicing rarely requires more than a few hours of downtime. And many TEGs placed into service during in the 1960s are still operational today.

## **B. DEVELOPMENT AND HISTORY**

Though the theory surrounding the generation of electricity via thermoelectric effect has existed since the mid-19<sup>th</sup> century, development of thermoelectric generators had not truly occurred until the 1950s. Preceding the 1950s, electricity generated through the thermoelectric effect was limited to a handful of experimental thermopiles.

Booming research and development in the area of TEGs began in the late 1950s through the growth of space and satellite programs. The SNAP-3B (System for Nuclear Auxiliary Power) is considered the first really practical TEG (Rowe 1995). Despite this device utilizing a radioisotope, polonium-210, the advent of a practical use TEG launched the development and array of applications for such devices.

Rapidly following the use TEGs in space, radioisotope and non-radioisotope powered TEGs became useful solutions for remote applications. From the late 1960s to present day, thermoelectric generators have been and are being used to power numerous devices ranging from spacecraft to navigational lights. Of course, the use of TEGs in communication applications is most significant to this research. Thermoelectric generators are heavily utilized in

the communications industry to enable the relay and broadcast of radio, television, microwave, and telephone signals to and through remote areas that would otherwise require other more expensive or less reliable alternatives.

### **C. ADVANTAGES**

The major advantages of TEGs are just recently being matched with applications involved in the growth of modern communications systems. More specifically, as communications system components located in rural and undeveloped areas becomes a growing requirement, the attributes of TEGs are married to those particular power requirements.

Dependability and autonomy, as a sole source of electrical power, are the strongest attributes of thermoelectric generators. The materials and design of TEGs allow them to operate in extreme conditions and without operator assistance. This characteristic is constrained only by the limitations of the fuel source and refueling of that source. Modern TEGs have very few or no moving parts, which further enhances their dependability.

In the same manner that little or no moving parts increases the dependability and lengthens the maintenance intervals for TEGs, the potential for highly efficient thermoelectric devices exists. Currently, most TEGs operate at approximately 5 percent efficiency. However, newer designs that involve the regeneration of heat from the heat source show a promising 80 percent theoretical efficiency (Rowe 1995). To put this into perspective, the typical gas powered generator operates at an efficiency of approximately



20 percent. Since TEGs have virtually no moving parts, which are where most generators lose the majority of their efficiency, energy losses due to friction are negated. Even if only half of the theoretical efficiency is realized in the near future, then thermoelectric generators can be considered far more efficient than most alternative sources of electricity.

#### **D. DISADVANTAGES**

The most significant deterrent from the use of thermoelectric generators is the initial cost. Relative to comparable alternatives, thermoelectric generators cost a considerable amount more in up front cost. Most organizations, businesses, and government agencies considering purchasing such devices will observe an 8 to 10 year payback period. The Department of the Navy would consider such a procurement to have a payback period of 10 to 15 years. As discussed in the Commercial Thermoelectric Generators section of this chapter, the observed lifetime of thermoelectric generators is over 30 years and growing. However, most business practices would prevent such an extended lifetime to be considered in an investment plan.

Thermoelectric device fuel source can also be a significant issue. Many applications are seeking alternatives that do not rely on the use of fossil fuels and/or natural gas. With that same consideration is the currently low efficiency of thermoelectric generators. The fuels that TEGs use are low in energy density. Additionally, the energy conversion involves the transfer of heat energy, and heat transfer is subject to extreme losses. The use of such fuel sources requires the cost of the fuel

and the cost of refueling to be factored in the operational cost of using TEGs. Depending on the severity of fuel dependency and difficulty in refueling, these costs can become quite significant in the lifetime cost of using thermoelectric generators as a sole power source solution. Especially in a disaster response scenario, where the availability of normally available fuel sources becomes an issue.

THIS PAGE INTENTIONALLY LEFT BLANK

## VII. FUEL CELLS

### A. BACKGROUND

A Fuel Cell (FC) is an electrochemical device that converts chemical energy, from a fuel, directly into electrical energy (Ahmed et al. 2008). This is most commonly seen in the conversion of hydrogen and oxygen into electricity and water.

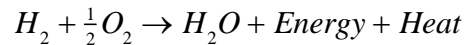

A British amateur physicist, by the name of William Grove, first discovered this principle in 1839. It was in 1960 that the FC first started to become a feasible and useful source of energy. This was the time when alkaline cells were developed for space applications and the success of this subsequently led to the development of FCs for more terrestrial applications in the 1970s (Aabakken 2006).

The basic construction of a FC, as seen in Figure 11, consists of two porous, catalyst-coated electrodes in an electrolyte. Electricity is then generated by feeding fuel (typically hydrogen) to the anode and oxidant, while oxygen from the air is fed to the cathode. As this occurs, electrons pass through an external circuit, while protons travel through the electrolyte. This process has no moving parts, which makes FCs extremely reliable.

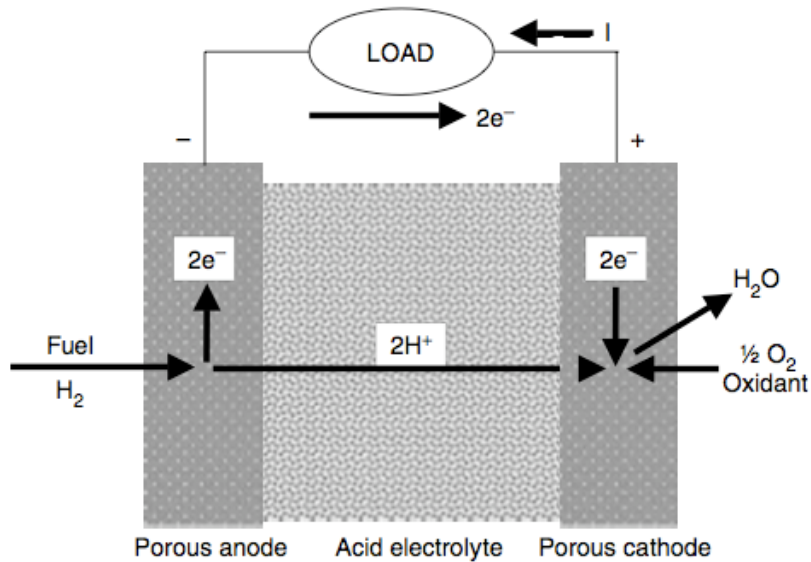

Figure 11. Basic Fuel Cell Schematic (From Kreith 2007)

## B. TYPES OF FUEL CELLS

There are many types of FCs that have been developed. The primary factor in classification is based on the type of electrolyte used, though operating temperature is also an important factor. This paper will briefly discuss six main types of FCs. Some of these characteristics will subsequently be summarized in Table 2.

### 1. Alkaline Fuel Cell

First is the Alkaline FC (AFC). As previously mentioned, this type of FC was the first to be widely used in conjunction with the U.S. space program. The main benefit of the AFC is that when under similar operating conditions of other FCs, the AFC exhibits the best performance. The main disadvantage is that AFCs are extremely susceptible to Carbon Dioxide (CO<sub>2</sub>) poisoning

(Kreith 2007). This adds significantly to the cost of the FC due to the need for having a process to purify the hydrogen and oxygen used.

## **2. Phosphoric Acid Fuel Cell**

Another type is the Phosphoric Acid FC (PAFC). This type of FC is seen as a first generation of modern FCs and one of the first modern FCs to see commercial use. The main advantage of a PAFC is that since they were designed for terrestrial use, they are much more tolerant of CO<sub>2</sub>. However, these FCs are much less powerful when compared to other FCs of similar size. This means that in order to achieve the same output power, when compared to a different type of FC, the PAFC will be considerably larger and heavier (Kreith 2007). They are also relatively expensive due to the need for a platinum catalyst.

## **3. Molten Carbonate Fuel Cell**

The Molten Carbonate FC (MCFC) is a high operating temperature (roughly 1200F) FC that is being developed for Megawatt (MW) scale industrial applications. The main advantages of the MCFC are a result of its high operating temperature. This temperature makes them less prone to various "poisonings" as well as allows for the use of non-precious metals as a catalyst. This also creates an environment where CO<sub>2</sub> and waste heat can be used to increase fuel efficiency. In turn, these factors then help to reduce cost. The downside is that the high temperatures accelerate breakdown and corrosion, which decreases FC life (Kreith 2007).

#### **4. Solid Oxide Fuel Cell**

The next type of FC is the Solid Oxide FC (SOFC). This type of FC has an extremely high operating temperature (roughly 1830F). This results in many similar advantages and disadvantages seen in the MCFC, such as the decrease in life. The SOFC is the most resistant to sulfur (S) poisoning and even immune to effects from carbon monoxide (CO). This allows the use of gases derived from coal as a fuel. Due to the extremely high operating temperature there are some additional disadvantages created. The SOFC has a very slow startup time and increased costs due to the stringent requirements on materials used for construction in order to retain heat and protect personnel (Kreith 2007).

#### **5. Direct Methanol Fuel Cell**

The next type of FC is the Direct Methanol FC (DMFC). This type of FC is the least developed of the FC technologies discussed and lags behind the other types by three to four years. One of the greatest advantages of the DMFC is that it is significantly easier to handle and store its fuel. The disadvantage is that as of right now, the DMFC is very complex, costly, and has undesirable pollutants as a byproduct of the reaction (Kreith 2007).

#### **6. Polymer Electrolyte Membrane Fuel Cell**

The last type of FC is the Polymer Electrolyte Membrane FC (PEMFC). Of all of the different types of FCs, the PEMFC is the most promising for small-scale applications. There are even FCs of this nature in development for portable use, such as the powering of a laptop (Figure 12).



Figure 12. UltraCell XX25 Fuel Cell (From UltraCell Corporation)

When compared with other FCs, the PEMFC has a high-power density along with low weight and volume. The PEMFC also has a low operating temperature, which allows them to startup quickly. However, a couple characteristics of the PEMFC result in increased costs. The PEMFC requires the use of platinum as a catalyst. This in itself is costly, but it also means that the FC is sensitive to CO poisoning. This increases cost due to the need for a mechanism to remove any presence of CO (Kreith 2007).

The effect of CO poisoning has a significant effect on the performance of the FC. Figure 13 shows the rapid degradation of PEMFC performance with CO presence in the order of parts per million. The issue is the presence of CO in the fuel itself, not in the operating environment of the FC. There are methods to reduce the presence/effect of CO, but as previously stated, this increases the cost of the FC.



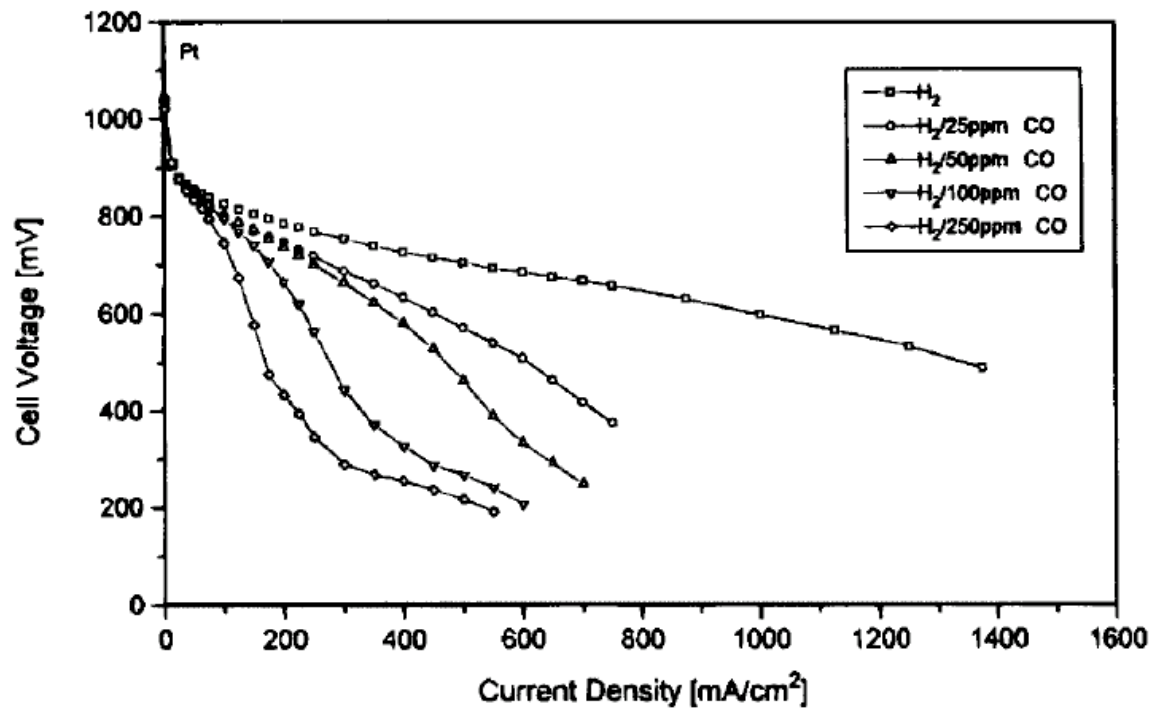

Figure 13. Effect of CO on PEMFC (From Baschuk and Li 2001)

Type	Operating Temperature (F)	System Output	Electrical Efficiency	Heat and Power Efficiency	Advantages
Alkaline (AFC)	194-212	10kW - 100kW	60%	>80%	<ul style="list-style-type: none"> <li>- Cathode reaction faster in alkaline electrolyte, leads to higher performance</li> <li>- Can use a variety of catalysts</li> </ul>
Phosphoric Acid (PAFC)	302-392	50kW - 1MW	>40%	>85%	<ul style="list-style-type: none"> <li>- Higher overall efficiency with heat and power</li> <li>- Increased tolerance to impurities in hydrogen</li> </ul>
Molten Carbonate (MCFC)	1112-1292	<1kW - 1MW	45-57%	>80%	<ul style="list-style-type: none"> <li>- High efficiency</li> <li>- Fuel flexibility</li> <li>- Can use a variety of catalysts</li> </ul>
Solid Oxide (SOFC)	1202-1832	<1kW - 3MW	35-43%	<90%	<ul style="list-style-type: none"> <li>- High efficiency</li> <li>- Fuel flexibility</li> <li>- Can use a variety of catalysts</li> <li>- Solid electrolyte reduces management problems</li> </ul>
Polymer Electrolyte Membrane (PEMFC)*	122-212	<1kW - 250kW	25-35%	70-90%	<ul style="list-style-type: none"> <li>- Solid electrolyte reduces corrosion &amp; electrolyte management problems</li> <li>- Low temperature</li> <li>- Quick start-up</li> </ul>

*\*Direct Methanol (DMFC) are a subset of PEM typically used for small portable power applications with a size range of about a subwatt to 100W and operating at 140-194F.*

Table 2. Comparison of Fuel Cell Technologies (Adapted From: Aabakken 2006)

### **C. FEASIBILITY**

With the current level of development within FC technology, the PEMFC is the most promising for this type of application. Two of the characteristics that make this the most suitable type of FC are the low operating temperature and, directly related to this, the quick startup time (Onar et al. 2008). These qualities make the PEMFC more suitable for different environments and operating conditions. The quick startup time allows for the ability to respond rapidly to fluctuations in power demand. Some other desirable qualities of the PEMFC include a high power density, relatively good efficiency, as well as durability. The two main downsides to this FC technology is the cost due to the need for platinum as a catalyst and vulnerability to CO poisoning due to CO presence in the fuel.

### **D. CONCLUSION**

Ultimately with today's technology, a stand-alone FC is not a good solution for this problem. This is mainly due to the difficulties in dealing with the storage and transportation of enough hydrogen to allow for sustained operation. However, it may be desirable to consider using FCs in conjunction with other hybrid solutions to supplement power and increase overall reliability. This is true since unlike other types of renewable energy; the FC is not dependent on weather conditions. This technology, much like the UC, has great potential for future use as the technology becomes more advanced.

In addition to the development of the FC technology, there is another interesting area of development to consider for future use. This area of development has to do with the supplying of hydrogen fuel for use within the FC, the goal being to reduce/eliminate the need to monitor and replenish fuel resources. This is done through the use of an electrolyzer. By harnessing excess power generated, that is not being used to charge batteries or power system loads, to operate an electrolyzer to produce hydrogen (Onar et al. 2008).

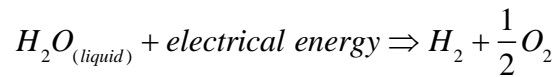

The downside to this process is that it requires more components, such as valves, pumps and compression motors in order to store the hydrogen. This in turn requires more power. This ultimately makes this scenario unfeasible for small-scale remote applications, but may change as the technology advances.

THIS PAGE INTENTIONALLY LEFT BLANK

## **VIII. ENERGY STORAGE SYSTEMS**

### **A. GENERAL**

Considering the use of renewable energy sources to provide power to remote network nodes will likely require the consideration of using an energy storage device as part of an overall power supply solution. The primary reason for involving an energy storage device is that the output from renewable energy sources is highly dependent on weather rather than demand. If the primary source of electrical power is to be derived from a power source that is highly susceptible to intermittences and the continuity of delivered power to the network node is needed, then the energy supply gap can be fulfilled using an energy storage device.

Energy storage devices store energy in the form of electrical energy (charge), mechanical energy, or thermal energy. More importantly, energy storage devices are capable of receiving energy as well as releasing it.

### **B. ENERGY STORAGE OPTIONS**

In order for the remote nodes of an interoperability network to operate with autonomy, in regards to power requirements, the node's power source must either possess a high level of independent reliability or have access to a source of alternative power. When utilizing power sources such as wind or solar as a primary means of electrical

power, stored energy options can be paired with them to ensure continuity of power during periods that the primary source is unavailable.

## **1. Electrical Energy Storage**

For the discussion of electrically stored energy, two broad categories will be examined: electrochemical energy storage and electric/magnetic field energy storage.

### ***a. Electrochemical Energy Storage***

The most commonly used method of storing energy for later use, in the form electricity, is through electrochemical energy storage. Batteries that utilize the electrochemical phenomena are classified in one of two major groups, primary and secondary. Primary and secondary batteries differ in that primary batteries are designed to discharge their stored energy once and only once; whereas, secondary batteries have the ability to discharge and recharge their stored energy. Primary batteries will be disregarded for potential use in powering remote network nodes because of this inherent disadvantage.

(1) Concept of Operation. A generalized schematic of a secondary battery is shown in Figure 14.

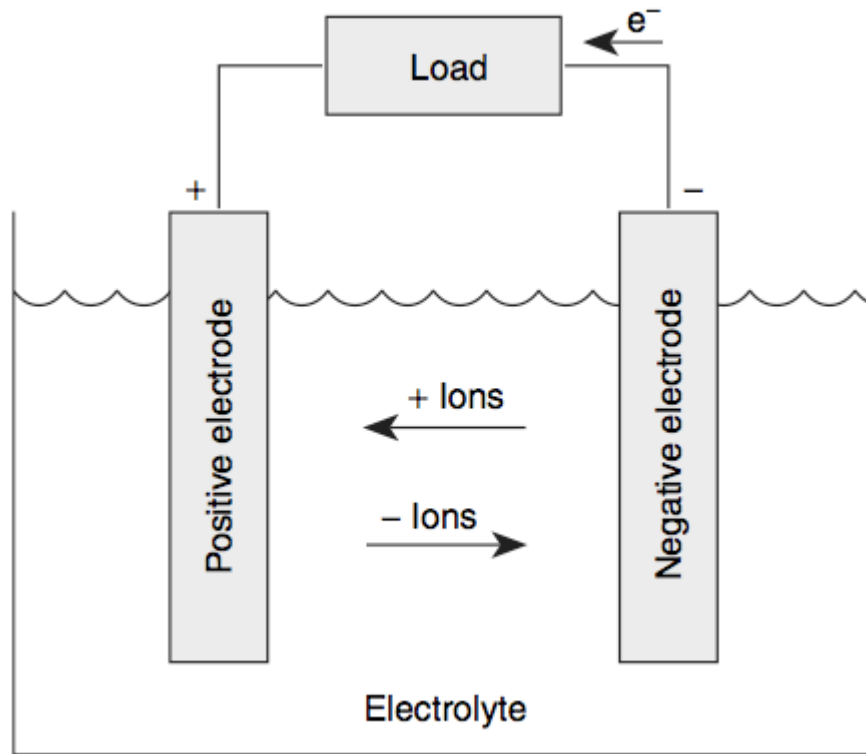

Figure 14. Schematic of a Generalized Secondary Battery.  
(From Kreith 2007)

From the schematic, the three basic parts, negative electrode, positive electrode, and electrolyte of a battery can be identified. During discharge, the negative electrode's purpose is to provide electrons to the load while the positive electrode freely accepts electrons. The electrolyte surrounding both the positive and negative electrodes allows for a chemical reaction to occur, which ultimately provides method of transferring negative ions from the positive electrode to the negative electrode and vice versa, thus completing the electrical circuit.



The recharging characteristic of secondary batteries comes from the fact that this flow can be reversed. When the electrical flow is reversed, electrons flow to the negative electrode, replenishing those lost during discharge, and the ion exchange in the electrolyte is reversed to return the conditions of all three battery components to nearly their pre-discharge state.

(2) Types of Secondary Batteries and their Characteristics. Secondary battery types and common names are based on one or some of the materials used in the chemistry directly involved with its operation. There are a vast number of battery chemistries utilized for battery design. For practicality, the variations most widely available and most commonly used are discussed.

The Lead-Acid battery is the most developed and longest used of all current battery types. The most basic materials used for a lead-acid battery include lead as a negative electrode, lead oxide as a positive electrode, and sulfuric acid as the electrolyte. Lead-Acid batteries in general are the most economical choice for a battery and they are widely available.

Within the categorical type of lead-acid, variations of the lead-acid battery exist. Those variations are based on the engineering of the sulfuric acid. A wet cell, or flooded cell, lead-acid battery contains a liquid form of the electrolyte. Of the lead-acid variations, this one is most affordable; however, as a consequence is susceptible to gassing and requires some periodic re-watering or electrolyte replacement. To overcome the effect of gassing and/or evaporation of the electrolyte, sealed gel

cells were created. These are effectively the same battery as a wet cell with the difference that a silica component is added to the electrolyte, which stiffens the electrolyte into a gel. Since no electrolyte maintenance is required, casings for the sealed gel cells are completely sealed to prevent any leakage from occurring. The last variation of the lead-acid battery is the Absorbed Glass Mat (AGM) cell. Design of the AGM uses a fiberglass-type separator to retain the electrolyte close to the electrodes in order to increase battery efficiency. The major trade-offs to using a sealed gel or AGM lead-acid battery are an increase in initial cost and slower charging rates.

Nickel-Cadmium (NiCd) batteries use nickel oxide hydroxide and metallic cadmium as the electrodes. Nearly all nickel-cadmium batteries are sealed to prevent leakage. These batteries are the most common alternative to lead-acid batteries; however these battery types are rapidly losing popularity to newer designed Nickel Metal Hydride (NiMH) batteries and lithium-ion batteries. The major benefit to nickel-cadmium over lead-acid is a much higher energy density, making it much smaller and lighter to lead-acid alternatives. Loss of faith in the nickel-cadmium battery is in part due to their high toxicity and recent affordability of the NiMH and lithium-ion alternatives. One of the other main issues with NiCd batteries is they are susceptible to the memory effect. This is when the battery is either charged or discharged to the same point many times. This is of particular concern when the particular charge or discharge point is not a fully charged or discharged state. The battery will exhibit characteristics of being fully charged or discharged even when it has not

reached the actual capacity of the battery. Despite the disadvantages, nickel-cadmium still has the advantage of a lower self-discharge rate compared to NiMH and is much less volatile compared to lithium-ion.

NiMH batteries are a direct successor to the nickel-cadmium battery. Chemically, the significant difference is the use of a hydrogen-absorbing alloy, vice cadmium, as a negative electrode. This change in chemistry offers NiMH batteries an energy density two to three times greater than nickel-cadmium batteries. Thus, a NiMH battery can store an equivalent amount of energy of a nickel-cadmium battery in about half the physical size. This type of battery has been available to consumers since late 1970, primarily for use in portable electronics such as cameras. In recent years, NiMH batteries have become heavily used in hybrid and electric car batteries. As the maturity of NiMH batteries continue, nickel-cadmium batteries become more and more obsolete and they draw closer and closer to being irrelevant since the advantages nickel-cadmium had over NiMH are diminishing rapidly. The low self-discharge characteristic of NiMH, which was previously mentioned, is progressively being improved with variations of separator designs, and the cost of NiMH is now nearly the same as nickel-cadmium and is projected to soon become more affordable than nickel-cadmium batteries.

The last of the battery types to consider is the lithium-ion battery. The name comes from the fact that the charge and discharge chemistry involves the exchange of lithium-ions between the positive and negative electrode. Cathodes are constructed from a lithium metal oxide and

anodes from a graphite carbon material. Like NiMH batteries, lithium-ion batteries began appearing in consumer mobile electronics in the late 1970s. The major difference in their applications was the flexibility in shape. Lithium-ion batteries can be manufactured with much more flexibility in terms of their shape. This attribute has made them the staple use for portable electronic devices with obscure shapes or voids to fit a battery. Many lithium-ion battery designs offer a higher energy density than the alternatives already discussed. However, these lightweight, compact batteries do come with their liabilities. In comparison, lithium-ion batteries require much more care, caution, and maintenance to preserve their lifetime. The cost for lithium-ion batteries are typically significantly more than the alternatives. There have also been several issues with the volatility of lithium-ion batteries (overheating, catching fire, etc.). Due to these issues, automakers seeking battery solutions for hybrid and electric automobiles continue to shy away from using lithium-ion. The result being that lithium-ion batteries available commercially are limited to small size, low voltage choices. Some 12-volt and 24-volt lithium-ion batteries are available for a significant price.

(3) Secondary Battery Characteristics. An understanding of secondary battery characteristics is necessary to properly differentiate between secondary batteries. Coupling a basic knowledge of battery specification to the specifications of remote network node equipment will assist in a selection of a battery or alternative solution. Battery performance parameters that require consideration for system implementation include:

- Ampere-hours
- Cell voltage
- Kilowatt-hours
- Battery life

The Ampere-Hour (AH) rating of a battery is a measure of the batteries energy storage capacity. It is a measure of the amount of electrical current (in amperes) that can be supplied to a load, multiplied by the duration (in hours) that the current is delivered. Ampere-hour capability can be increased by arranging cells in a parallel bank configuration. The upper half of Figure 15 illustrates how connecting multiple 100 AH battery cells in parallel increased the battery bank's current capacity. More specifically, two 100 AH cells in parallel yields a total capacity of 200 AH. Similarly, four 100 AH cells in a parallel configuration can provide up to 400 AH. A battery's ampere-hour rating will provide insight to the longevity of current supplied to a particular load.

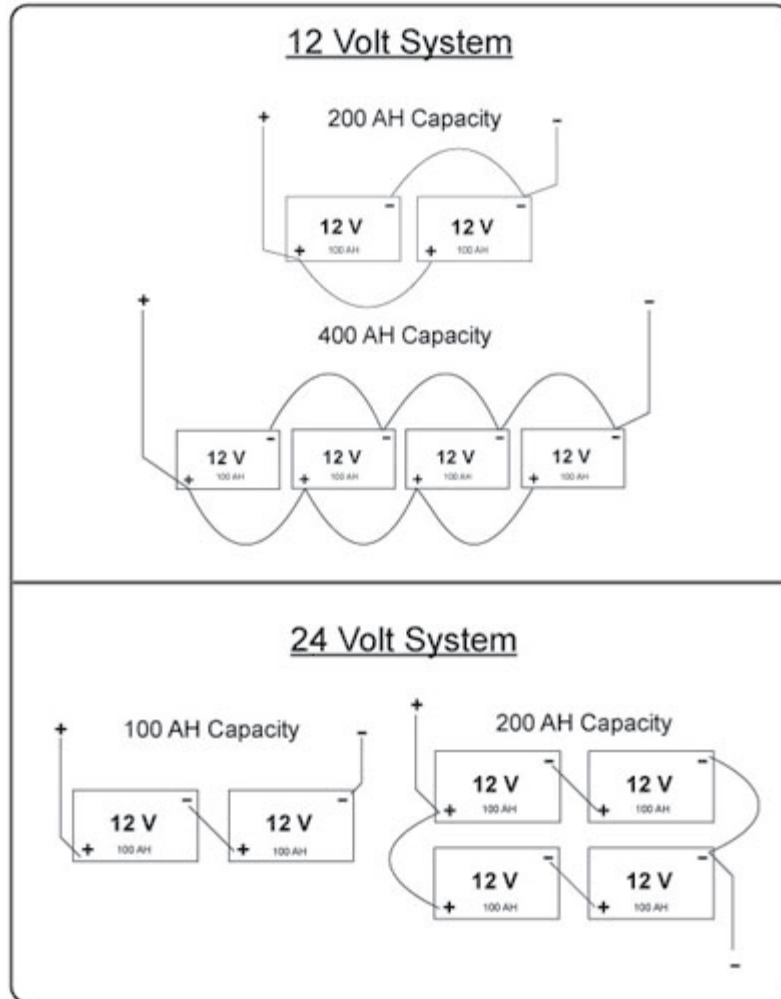

Figure 15. Sample Battery Configurations Demonstrating the Relationship between Battery Interconnections and Battery Bank Output Capacities. (From Sundance Solar)

Cell voltage is simply the voltage potential that exists across the battery cell terminals. System equipment and loads require a certain voltage, or voltage range, for proper operation. The voltage supplied to a load from battery cells can be manipulated by arranging battery cells in a series configured battery bank. In the lower left diagram of Figure 15 it is illustrated how connecting multiple 12V battery cells in series increased the battery bank's voltage capacity. In this configuration example, two

12V cells are electrically connected in series to yield a total bank voltage of 24V. It must be kept in mind that battery bank configurations obviously increase the number of batteries involved in the overall power system.

Another measure of battery storage capacity is kilowatt-hours. Similar to ampere-hour, kilowatt-hour is derived from the product of the battery's ampere-hour rating and the battery's supplied voltage. That resultant product is reduced by a factor of 1000 to convert from watts to kilowatts.

Battery life is an important aspect of a battery's characteristics. Unfortunately, expressions of battery life are convoluted. Most often, battery cycle life, or battery cycles, is most synonymous with battery life. This measure defines the number of complete charge-discharge cycles the battery is capable of. Though this provides a good deal of comparative insight, the frequency of cycles and effects of partial cycles are not encapsulated in the specification. Additionally, battery shelf life and battery calendar life should be considered. These consequential attributes are often overlooked by consumers and are not strongly advertised by manufacturers. A battery shelf life is the time that a battery can be stored in an inactive state before losing its usability. The calendar life is the overall time, regardless of use or non-use, before its usability expires.

(4) Secondary Battery Selection. Proper battery selection is highly dependent on the desired battery type (lead-acid, lithium-ion, etc.) and the performance

characteristics of the battery. Selection of a battery should include consideration of the following system attributes:

- Peak power/voltage/current demand - the battery must possess a power, voltage and current rating sufficient to meet peak load demands
- Battery power duration needs - a determination of the expected frequency and duration that loads will rely upon the battery for power is needed to determine appropriate ampere-hour and/or kilowatt-hour rating of the selected battery.
- Physical measures - size, weight, and number of batteries has consequential effects on the power system's mobility.

Battery selection is not simply a comparison of the specification and features mentioned. An extensive commercial market for batteries widens the variation of choices even further. Maintenance requirements, warranties, susceptibility to extreme temperatures, and variants in charging/discharging characteristics are among a few of the reasons that battery selection can become an extremely daunting task in the overall power system design.

***b. Electric/Magnetic Field Energy Storage***

Energy storage that operates on the principle of storing energy in the form of a magnetic field, such as



Ultra-Capacitors (UC) and Superconducting Magnetic Energy Storage (SMES), are not widely available for small applications. Those applications for such devices that do exist are primarily for the purpose of controlling the quality of power rather than storing and supplying power. As the UC technology continues to progress, we are starting to see a move to replace traditional battery storage with UCs. Currently an UC can lose approximately 10 percent of its charge each day (Kreith 2007). Specific to its application toward powering remote network nodes, SMES and UC devices may not be developed enough to be utilized as a storage device, but these types of technologies can help to supplement the energy storage capabilities of the system.

When comparing UCs to batteries there are a few tradeoffs with the current level of technology. One of the big advantages of an UC has to do with life of the component. Batteries utilize chemical energy, which over time degrades the ability of the system to hold a charge. An UC, on the other, the charge and discharge process is purely physical which provides the ability to release more energy, faster, and can be cycled countless times without performance degradation. One of the biggest disadvantages of UCs are that they have a very poor energy density when compared to batteries and as previously mentioned have a daily degradation of charge. Batteries are also a more readily available technology as well as lower initial cost when compared to UCs.

## **2. Mechanical Energy Storage**

Mechanical energy storage is the oldest method for storing energy for future use. Besides its historical long

running, mechanical energy storage is also the most widely used in commercial applications. Common applications of this storage method include pumped hydro, compressed air, and flywheels. However, it must be kept in mind that the benefits and efficiencies of the mechanical energy storage systems used in commercial applications are derived heavily from their scale size.

Despite the fact that mechanical energy storage systems are feasible, their practicality for implementation in delivering electrical power to remote network nodes is negligible. Market availability of mechanical energy storage systems on a scale needed for powering small electrical loads, such as those incorporated in a remote network node, are rare and scarce. As these devices are scaled down toward sizes usable toward this specific application, the discharge rates of mechanical energy storage systems diminish. The result being that mechanical energy storage systems lose their power-supplying longevity in smaller applications. Large commercial applications of mechanically stored energy have storage expenditure times on the order of several hours. The power supply deficiency that needs to be fulfilled with an energy storage device in a remote node application is likely a result from variations in weather; hence, the necessary coverage time will be on the order of several hours or more.

With the current technology surrounding mechanical storage of energy being extremely limited to large-scale applications, as well as being very inefficient due to

multiple energy transformations, such methods are rejected for consideration as suitable energy storage device for remote network nodes.

### **3. Thermal Energy Storage**

The principle of thermal energy storage is the absorption of heat energy by a material that is later released in the form of heat energy. Thermal energy is either stored by raising a materials temperature, known as sensible-heat, or by converting the physical phase of the material (solid to liquid or liquid to gas), known as latent-heat. In both cases, the heat energy inputted into the material is released from the material when the energy is needed.

Applications using thermal energy storage are limited primarily to applications where heat energy holds a high commodity value (Kreith 2007). This is primarily because heat energy is considered to be lower grade energy due to the difficulties and inefficiencies in converting heat energy into other forms of energy, such as electrical energy.

Thermal energy storage systems appear to have little potential for applications in the powering of remote network nodes. Node equipment generates an insignificant amount of thermal energy and has no direct means for utilizing such energy. The use of stored thermal energy would require additional means of converting the stored thermal energy into useful electrical energy. Current methods and technologies for doing so are extremely ineffective compared to mechanical and electrical storage alternatives.

### C. SUMMARY OF ENERGY STORAGE OPTIONS

In examining the several options available for storing energy, secondary batteries are currently the most suitable means for implementation in a power system for remote network nodes. This conclusion comes primarily from the fact that secondary batteries are the only energy storage devices that possess the energy density necessary to practically power remote network node devices. Figure 16 is a plot that depicts the general energy density and power density of energy storage devices based on current technologies surrounding each of the energy storage methods.

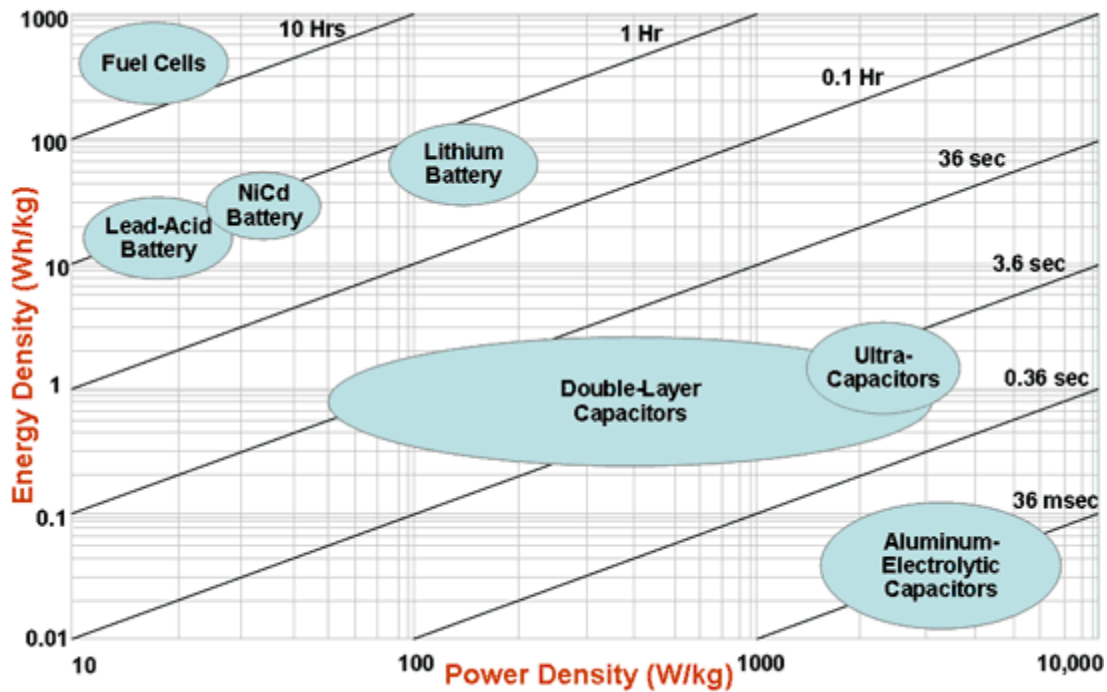

Figure 16. Ragone Plot Energy Density and Power Density of Various Electric Energy Storage Devices. (From The Electropaedia)

The significant take-away from this figure is, fuel cells aside (fuel cells are discussed in Chapter VII), that only electrochemical storage batteries possess the power duration (magnitude of several hours) to make energy storage a consideration for powering remote network nodes. Secondary batteries are a proven and readily available technology to fulfill potential energy storage needs in an interoperability network. They are extensively used for such purposes already, and will continue to, pending the emergence of developments in the other energy storage techniques. As previously mentioned, an important area to consider for future development will be in the area of UCs. As this technology continues to become more prevalent and advanced, the UC will potentially make a well-suited replacement for the battery.

As it is with all components of a system, the monitoring and evaluation is important to ensure system availability. This is just as important with the energy storage system. Many of these factors are discussed in detail in Chapter X, within the implementation section.

## **IX. HYBRID POWER**

### **A. BACKGROUND**

A hybrid power system consists of two or more forms of a power source in conjunction with a storage device (Ahmed et al. 2009). The ultimate goal of this type of system is to improve the overall reliability of the system. In our society, this is most commonly seen in the various types of hybrid vehicles. The early mopeds that were powered by both the physical strength of the rider and a small engine are an example of an early hybrid vehicle. Another example is a sailboat that can also utilize a motor. Today the most common type of hybrid vehicle involves the use of electric batteries to power an electric motor along with an internal combustion engine powered by gasoline or diesel fuel. The main purposes of having a hybrid vehicle are to reduce fuel consumption and be more environmentally friendly.

Non-vehicular hybrid systems are most often in the form of a renewable energy paired with a fossil fuel based generator. This is because we want the advantages gained from using a renewable energy source but desire to maximize system reliability. Having a fossil fuel based generator, such as a diesel generator, achieves this since operation of the generator is independent of changing factors like weather. The downside of utilizing a diesel generator is that there will be increased costs due to fuel use and maintenance. A generator has many more moving components that are susceptible to wear and damage, which require more

preventative maintenance to ensure operation as well as the need for fuel replenishment.

Often times a stand-alone hybrid system is utilized in areas that are remote and many do not have access to the utility grid (Valenciaga and Puleston 2005). In fact, it has been shown that a stand-alone hybrid system, designed to meet the electrical needs of a typical household, only needs to be a few miles from the grid in order to be cost effective (Kellogg et al. 1998). This is in comparing the cost to run power lines to the remote location versus the cost of the hybrid system, assuming a 20-year life expectancy.

Ultimately no matter what the purpose of the system, there are a few common goals sought by using a hybrid solution. One of these goals is to increase system autonomy. This is accomplished by combining technologies in a manner that either eliminates the need for or reduces the dependency on a fossil fuel based generator (Valenciaga and Puleston 2005). This in turn eliminates or reduces the need to store and replenish fuel. Another goal is to reduce costs related to the energy storage system. Batteries have a significantly smaller life expectancy when compared to other system components such as wind turbines or solar panels. This causes them to have a relatively high contribution to the lifetime costs of a system (Kaldellis 2003). By combining multiple types of renewable energy sources, this leads to a reduction in storage requirements and therefore overall cost.

Those facts tie into another goal of hybrid systems, that being to reduce the probability of an energy shortage.

This is accomplished on two fronts. This first is seen through utilizing different technologies that draw upon different sources for power. This allows the system to be able to draw upon the advantages of the individual technologies in order to overcome the disadvantages; such as in a renewable power source combined with a fuel based generator. The renewable source is able to reduce the operating time of the generator, which reduces fuel use and wear on the system. While the generator provides power when environmental conditions do not support operation of the renewable system.

The second aspect is with respect to the storage system. The need for system reliability contributes to the design of the storage system. By combining renewable energy sources, it creates a much higher generating capacity. This results in minimizing the requirements of the storage system; and more importantly, improved reliability of the overall power system. This is especially important for telecommunication applications, where reliability is one of the most critical components to system operation (Ahmed et al. 2008).

## **B. TYPES**

Hybrid means a combination of two or more different things. When applied to power systems, this results in the combination of different generation and storage methods. With all of the different technologies available today, there are numerous possibilities for types of hybrid power systems. However, there are certain combinations of technology that are more common and make more sense than



others. Ultimately the decision depends on what the operating conditions/environment is, what the needs of the system are, and the costs.

Some of the technologies to choose from when designing a hybrid system are: wind turbines, photovoltaics, thermal-electric generators, diesel generators, biomass, hydropower, fuel cells, ultra-capacitors and battery storage. Among these energy sources, wind turbines and photovoltaics are often used as a primary source of power within a stand-alone hybrid system. These technologies have been in use for a long time and are well developed. When looking at a secondary or backup source of power for a hybrid system, diesel generators and battery storage systems are often used. As other technologies, such as fuel cells and ultra-capacitors, continue to develop they will likely present new options and capabilities for use in hybrid systems.

One future capability sought after would be replacing batteries with UCs for energy storage. As discussed in Chapter VIII, UCs have not yet reached the point of being able to replace battery storage. However, using UCs within a system can help to reduce overall size and cost of a system due to their ability to meet peak demands and other transient conditions (Onar et al. 2008). Since UCs do not have many of the disadvantages of batteries, they would be a very desirable energy storage replacement once the technology becomes more mature.

Another future capability would be the incorporation of fuel cells. In Chapter VII it was discussed how the PEMFC is currently the best suited FC for hybrid applications. This is due to its low operating temperature and fast start-

up time. Fuel cells have some of the disadvantages of other generators such as the need to store and replace fuel but without the concerns of many moving parts. It was also discussed how there are areas of development in self-replenishment of hydrogen fuel through the use of an electrolyzer. This capability is likely far away from being practical for small-scale remote applications. However, the ability to incorporate PEMFC technology is rapidly becoming a feasible alternative.

In order to provide enough power to remote network nodes, to ensure operation 99.99 percent of the time, a hybrid solution will need to be implemented. Technically you could essentially provide continuous power through the use of a diesel generator. However, this would either require a massive fuel storage capacity or continuous refueling operations. This would defeat the purpose of the goals in developing a small-scale remote node power system, as well as have an enormous effect on maintenance/upkeep related costs.

In order to provide continuous power, in a variety of conditions, the only practical solution involves a hybrid design. Depending on the location and system requirements, there are a variety of viable solutions. These solutions could vary from a single primary power source with ample storage capacity, a combination of primary power sources to ensure continuous power availability, or a combination of the two. A combination of primary sources in conjunction with a storage system is the best solution and the design of such a system is described in the next section.

## **C. SYSTEM DESIGN**

There are many factors to take into consideration when selecting the technologies to be used in a hybrid system. Each of the different power options bring with it advantages and disadvantages. When looking within the scope of providing power to remote telecommunications node, there are a few technologies that are better suited. In this type of application we want to have sufficient power supplied, with the highest possible reliability, and as much system autonomy feasible.

### **1. Primary Power Source**

With respect to the primary power source within the hybrid system there are two preferred candidates. Both wind power and solar power are good choices for a primary power source. Each individually, when paired with a storage system, could be designed to cover all of the system requirements. However, depending on the environment and availability of renewable resources this would likely result in the need for a large storage system, which as previously discussed is a large contributor to system cost (Kaldellis 2003). Relying on a single primary power source would also require a much larger wind turbine or many more photovoltaic panels. Rather than rely on one source, it would be better to design a hybrid system which incorporates both wind and solar as primary power sources. This would allow for the reduction in size of individual subsystems, more importantly the storage system, as well as increase the reliability of the system (Borowy and Salameh 1996).

## **2. Secondary Power System**

Even with a well-designed primary power system, it is important to have a secondary power system. With a primary system that is dependent entirely on environmental factors, there will be periods of time in which there is insufficient wind or sunlight present to meet the system's needs (Onar et al. 2008). The main solution for this is having battery storage as part of the secondary power system. The best solution in this case is a combination of deep-cycle batteries, with the total number of cells depending on the load requirements. These batteries hold up better to various cycling conditions while maintaining charge capacity.

Even the best systems can experience extended periods of time without adequate wind or sun. In these extreme and possibly rare situations, even a good battery system has a finite amount of energy without being replenished by the primary system. In a system desired to be operational 24 hours a day, 365 days a year it may be beneficial to have an additional energy source within the secondary power system.

In addition to batteries, a thermoelectric generator is an excellent backup power source to consider. By incorporating a TEG into the secondary power system, this provides a source of energy independent of the environment. It does have the disadvantage of needing fuel replenishment, but with a well-designed system, the TEG would only operate in extreme circumstances. Subsequently it would be expected that refueling would not be required on a regular basis. A thermoelectric generator also requires very little maintenance since there are virtually no moving components.

This is very different when compared to typical backup generators, such as a diesel generator. Not only are TEGs a very reliable system, hybrid-sensing electronics can also be incorporated into the system that would only start the generator when battery charge reaches a set level. This allows for maximum fuel efficiency of the secondary power system.

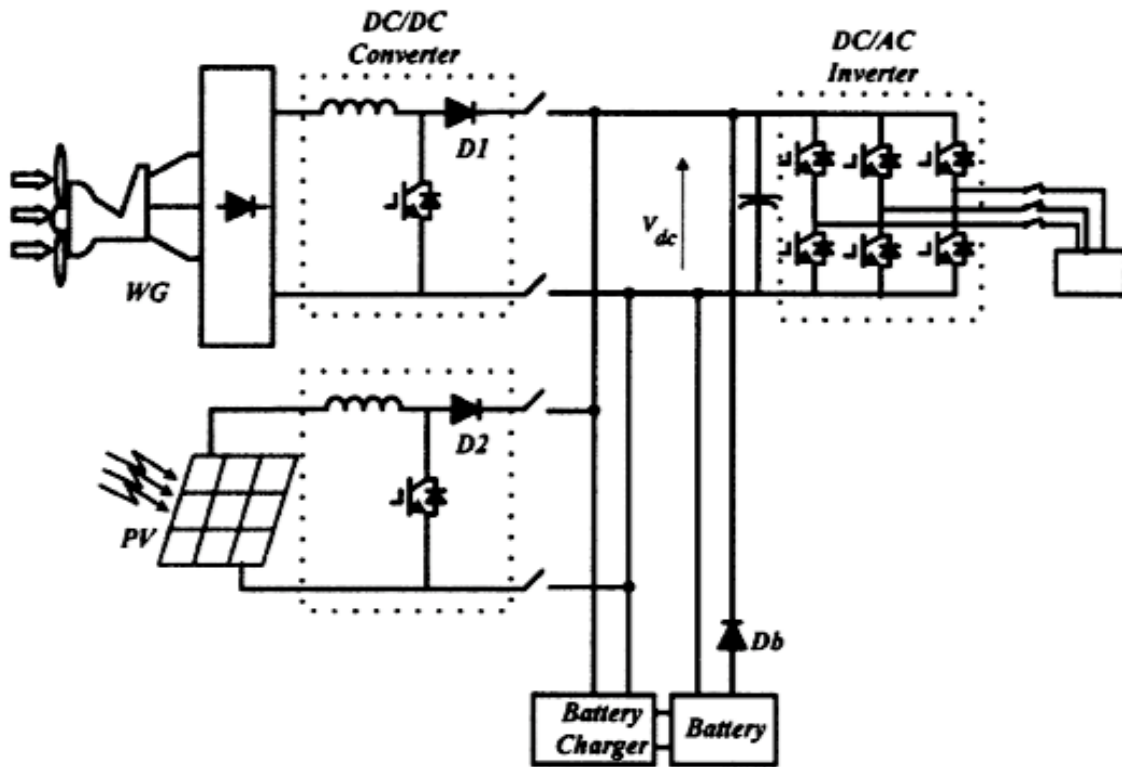

Figure 17. Equivalent Circuit of Hybrid Energy System (From Ahmed et al. 2009)

### 3. Miscellaneous Components

Just as in the systems discussed in Chapters IV and V, there are a few miscellaneous components required in order to make a functioning system. These same components: rectifiers, charge controllers, and inverters are also needed to create a hybrid system. Any other advanced

equipment for monitoring and control of the system can be incorporated for added functionality, but is not required for basic operation. Figure 17 shows a basic system layout of a hybrid system and if a TEG were to be added it would only need to be connected in parallel with the other power sources on the DC Bus.

#### **4. Complete System**

The final decision on system components really comes down to what will perform best for the region and application in question. The next section will discuss some tools that can be utilized to help make these types of decisions. There are situations in which it can be very obvious what the primary and secondary power sources should be. If the site is in an arid region that is always sunny, then it may be sufficient to select a solar system with battery backup. If correctly sized, then the probability of power loss may be sufficiently reduced. The same could be true for a wind system with battery backup, in an area of the world that experiences a lot of wind. The majority of the time, a combination of solar and wind with battery backup is likely to provide the best solution. By combining the technologies, it provides additional advantages to offset the disadvantages and significantly improves factors related to operational availability as described in Chapter II. It also helps to reduce the size of individual subsystems, which as mentioned, reduces associated costs. Such as lifetime costs in the case of batteries, and maintenance costs associated with the wind turbine due to reduced size and wear.

#### **D. SYSTEM SIZING**

A person could seek out suppliers and purchase a wind turbine, solar panels, batteries and all other equipment and construct a hybrid system. However, it is unlikely that the constructed system would be the most reliable, energy efficient, or cost effective. There are techniques that can be utilized in order to more accurately design a system that maximizes reliability while minimizing cost.

There are two basic sides to system optimization. The first is with respect to the various power components. That is having the optimum wind turbine, with the ideal number of solar panels and batteries. The other aspect is the economic optimization. This half, while directly related to system design, may also have other additional factors to consider beyond costs directly related to the system.

It is important to remember that if the most important factor in system operation is its reliability then many other economic considerations may be inconsequential. As any system is designed to be more resilient and robust, it naturally increases the cost of the system. This will be seen in having larger primary and secondary power generation components as well as increased maintenance costs to ensure continuous operation. That being said, while an economic evaluation may be irrelevant when it comes to meeting the requirements of the system, the comparison can still be utilized to compare alternative power solutions.

##### **1. Economic Optimization**

When doing an economic evaluation of the system, many of the standard evaluation techniques can be utilized.

These are techniques such as Life-Cycle Cost, Net Present Value, Benefit-to-Cost Ratio, Internal Rate-of-Return and Payback Period. An additional methodology that can be very useful is the Levelized Cost of Energy (LCE) method. This is basically the entire cost of the system divided by the energy supplied from the system. This takes into consideration capital costs as well as lifetime maintenance costs. This is generally used to compare the cost of one system to what it would cost if the same power were supplied from another system (Yang et al. 2007).

## **2. System Component Optimization**

As important as cost is, it is even more important to optimize the match between various power system components. This will help to achieve the best possible investment, along with system reliability, which is likely a higher priority than cost when considering a first responder or military telecommunications application (Ahmed et al. 2008). In accomplishing system optimization, a common method is the Loss of Power Supply Probability (LPSP) method.



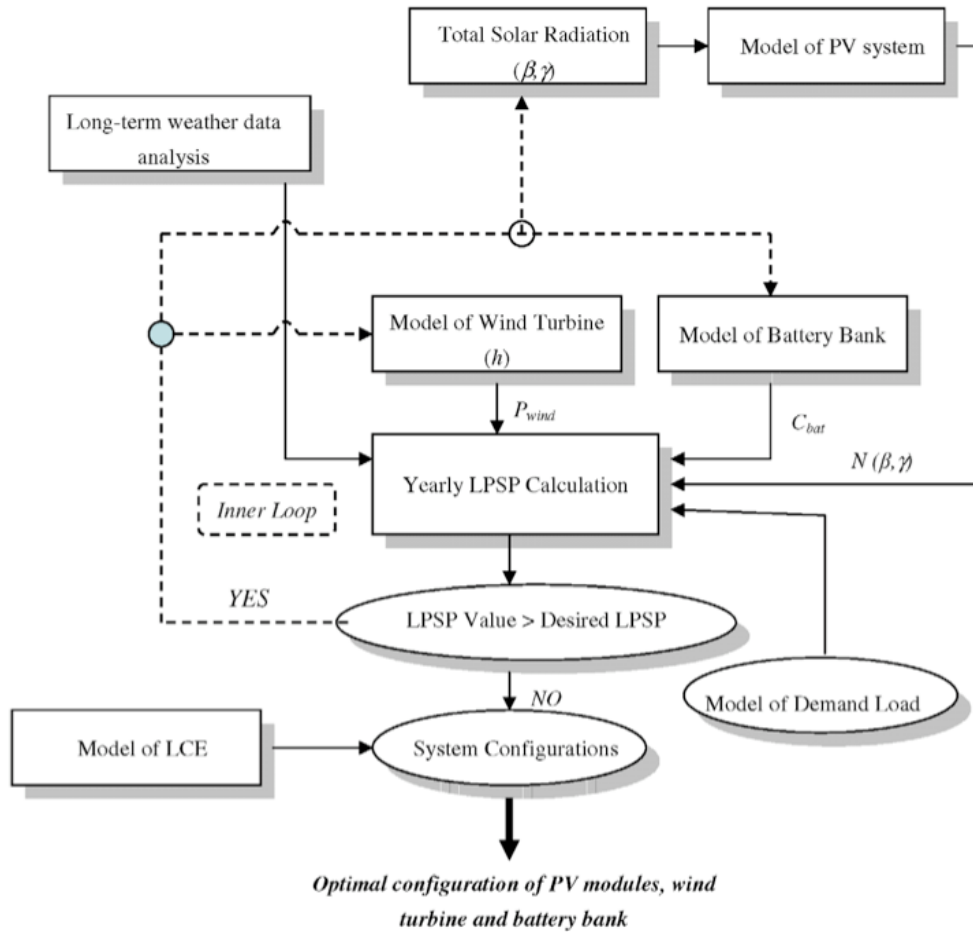

Figure 18. Hybrid Solar-Wind System Optimization Sizing Flow Chart (From Yang et al. 2007)

The LPSP method takes into consideration many system attributes with the intent of maximizing system reliability. In a wind-solar hybrid system, this would include factors such as wind system rated power and height. It would also consider the capacity and orientation of the photovoltaic system as well as the capacity of the battery storage system (Yang et al. 2007). In order to accurately determine this information it is also necessary to have data on the availability of resources at the location of the site. This would be data such as wind speed and solar radiation in the region. Optimum tower height is a function of the wind

profile of the region as well as any obstacles in the area. The optimum solar panel orientation is primarily a function of the latitude of the site location. All of these factors can be used in the LPSP calculations, which determine what the probability is that the hybrid system will be unable to satisfy load demand due to insufficient power. By knowing the reliability requirements of the system, this can be used to optimize any input factors that are controllable, such as increasing the number of batteries or solar panels.

This optimization model, as shown in Figure 18, also can take into consideration LCE. One of the most important aspects of this is that it can take into consideration factors such as capital costs of the system, as well as lifetime maintenance costs. When designing a system that will operate in remote areas, maintenance costs can be a significant factor. This is due to factors such as having to transport personnel and equipment to the location in order to be able to monitor the system and perform any preventative/corrective maintenance required.

#### **E. CONCLUSION**

It is essential to properly analyze site conditions and understand system requirements when developing any power system. Without understanding these factors, it will not be possible to design the most optimal solution. Even with the best solution there could exist the possibility that an economic analysis may find that an alternate power source is more cost effective. It is important to remember factors that may not get captured in an economic analysis such as system reliability or autonomy. These are two of the factors, which are very important, especially in the first

responder and military environment. This is why the hybrid system with wind and solar as a primary power source with batteries and possibly thermoelectric as a secondary power source is a very effective combination.

## **X. POWER SYSTEM MONITORING AND MANAGEMENT**

The existence of network equipment alone does not constitute a working network. In order for a network to exist and persist, the network and its components require observation and management. Additionally, the benefits of centralized management of communication network nodes can be measured in terms of direct and indirect operating costs. Inclusive of the network are the power supply systems. In many cases, this aspect of the network is neglected or taken for granted. This is due in part to the fact that most networks rely strictly upon commercial power. Additionally, there is rarely a need or the ability to monitor and manage commercial power as a primary power source. In cases of severe necessity, reliability of network device power might be enhanced with an Uninterrupted Power Supply (UPS) or even a back-up generator of some sort. But even in those situations, the monitoring and management of secondary power sources are limited in use until the primary source returns. For remote interoperability network nodes, the management of the source(s) of electrical power is essential for to the reliability and effectiveness of the network.

### **A. GENERAL**

Power system observation for the sake of power system management requires either direct observation or remote monitoring capability. Direct observation, though it is very simplistic, and the more reliable method, requires personnel presence. This is the very reason that the ability to monitor power systems remotely is necessary for

network nodes located in distant locations. Accomplishing remote monitoring of power supply systems requires some understanding of methods, procedures, and tools that pertain to remote monitoring and management of networks and network devices.

## **B. SIMPLE NETWORK MANAGEMENT PROTOCOL (SNMP)**

Simple Network Management Protocol (SNMP) was introduced in 1988 to meet the growing need for a standard for managing IP devices. SNMP is an obvious choice for the overall management of an interoperability network since SNMP is the standard for managing IP devices and an interoperability network is merely an IP-based extension of the IP-intensive internet. As for the issue of power system management, SNMP is not limited to only those devices directly associated with IP networks, such as routers, servers, printers, etc, but can also be used to manage more atypical network devices like power supplies.

### **1. SNMP Components**

An SNMP managed network consists of three components:

- Network Management Stations (NMSs)
- Managed devices
- SNMP Agents

NMSs are network devices that execute applications that monitor and/or control managed devices. They are servers running some software application designed to handle the exchange of management information and convey the information to a network operator or administrator in a

useful manner. NMSs often reside in designated network control locations, often referred to as Network Operating (Operations) Centers (NOC).

The managed device and SNMP agent components of SNMP that are of most concern to the topics of this thesis. The managed devices, in our case, are the remote node power sources. The SNMP agent is the network management software that resides within the managed device, enabling the managed device to portray managed device parameters to NMSs.

The basic architecture involved with SNMP network management is illustrated in Figure 19 below. As you can see from the figure, a NMS communicates with agent using the network as the communication medium.



Figure 19. Basic SNMP Network Management Architecture. (From Breakthrough Ltd.)

Information packets that are communicated between NMSs and agents in SNMP protocol are called Protocol Data Units (PDUs). There are a number of PDU variations, depending upon the SNMP version being executed. The most basic and essential PDUs consist of GET, SET, and TRAP. The NMS relies upon the agent to retrieve and/or update managed device information. Information that is considered pertinent or logical to the agent and NMS are defined by the Structure of Management Information (SMI) and the Management Information

Bases (MIBs) associated with the agent. For simplicity, Figure 19 shows only a one-to-one NMS-agent relationship, and likewise a one-to-one agent-MIB relationship, when in fact the NMS-agent relationship can be a one-to-many, many-to-one, or many-to-many relationship. Any given agent can utilize any number of MIBs.

## 2. SNMP Operations

SNMP operations are the methods that are used to gather SNMP management information. Below is a list of the most basic SNMP operations used and a brief description of the operations.

- **Get** - The *get* request is initiated by a NMS and sent to an agent. When the agent receives the request, it will attempt to gather the requested information and relay it back to the NMS in the form of a *get-response*. The *get* operation is used for retrieving a single MIB object at a particular time. In terms of management, this operation only returns a one time, instantaneous value; making it an often time consuming method for retrieving management relevant information.
- **Set** - The *set* operation is similar to the *get* operation in that it is initiated by a NMS. However, rather than requesting information from the agent, the NMS is directing some change to a managed object or the creation of a new MIB table entry. The *set* operation is

utilized more for the control aspect network management, rather than monitoring. Confirmation of a properly executed *set* request is typically performed using a *get* request and subsequent *get-response*.

- Trap - The *trap* operation is one of the most important SNMP operations for network monitoring. A *trap* is a way of enabling an agent to notify a NMS if and when something significant has occurred. A *trap* message originates from an agent when a pre-configured event has occurred. The UDP message is sent to the destination IP address of a NMS. If all goes as expected, the NMS is notified of the significant event without any action on the part of the NMS. However, since SNMP utilizes UDP, there is no guarantee of the delivery of the message, nor would the agent ever become aware of the NMS receiving or not receiving the message.

### **3. Management Information Base (MIB)**

Agents and NMSs are concerned with the management of objects and object behavior. A list of those objects and their defined behavior is defined within the SMI. It is this list that defines the information that a NMS can use to determine operational characteristics of the devices, which an agent resides on. In order for the NMS and agent to work together in accomplishing the goal of device management, they must have a way of knowing what devices exist and a



context to exchange information about them. This is accomplished with the use of Management Information Bases (MIBs).

MIBs are a database of the objects that the agent tracks. In the MIBs, the information that will be exchanged between the NMS and agent are defined. Much like a dictionary, the MIB provides a textual name for a managed object and explains the meaning of it (Mauro and Schmidt 2001).

MIBs can be defined by standards organizations, private enterprise, or individuals. MIBs that are standardized by organizations, such IETF, aim to provide general-purpose management information. An example of this being MIB-II; which defines things such as interface speeds, Maximum Transmission Unit (MTU), and octets sent/received. MIB-II is a MIB that all agents implement. The ability to develop MIBs for particular applications allow for the monitoring of features or parameters not observed in any standard MIB.

#### **4. SNMP Versions**

There are currently three versions of SNMP, SNMPv1, SNMPv2, and SNMPv3. Table 3 is an overview the three SNMP versions.

SNMPv1	Original version of the protocol. Defined by RFCs 1155 and 1157.
SNMPv2	Enhanced PDU types and MIB structure. Defined by RFCs 1901, 1905, 1906, and 2578.
SNMPv3	Secure version of SNMP. Provides security features to ensure message integrity, provide authentication, and enable encryption. Facilitates remote configuration of SNMP entities. Defined by RFCs 1905, 1906, 3411, 3412, 3414, and 3415.

Table 3. Summary of SNMP versions.

### C. USING SNMP TO IMPROVE AVAILABILITY

SNMP can be used to promptly detect or even preemptively anticipate a system failure. Traps are heavily used for this very purpose. Upon the activation of pre-established trap conditions, network operators and technicians can be rapidly notified of the condition in numerous ways, including NMS alarms, email notification, or even cellular phone text messages. Through this reduction in time between when a fault occurs and the ability to recover from the fault, overall system availability is enhanced. Revisiting the definition equation of operational availability, it can be noted that from a fault management perspective, availability ( $A_o$ ) can only be strengthened by elimination or reduction of the downtime. It is exactly

that variable that proper utilization of SNMP will affect and ultimately lead to a higher degree of system operational availability.

$$A_o = \frac{Uptime}{Uptime + Downtime}$$

#### **D. REMOTE NODE POWER SOURCES AS SNMP MANAGED DEVICES**

When it comes to what types of devices that can be network-managed devices, the possibilities are near endless. There is an ever-growing number of SNMP enabled devices and methods for SNMP-enabling existing devices are being developed all the time. This is also true for computer and network power sources.

SNMP-enabled network energy systems can be categorized in one of three groups: (1) SNMP energy equipment, (2) Energy equipment with intelligent interface, or (3) Old energy equipment with no existing interface (Almqvist and Wikstrom 1994). Energy systems belonging to the SNMP energy group possess the SNMP interface and integrated intelligence necessary to directly connect to the management system with no need for adaptation. Energy equipment that has the interface, but requires management information mediation in the form of a translation tool is considered to be energy equipment with intelligent interface. The last group is considered to be any device that lacks an SNMP interface, and requires the adaptation of an interface to allow for the use of SNMP. It is here in the last category that power devices pertinent to remote node application will mostly be part of.

Currently, the majority of SNMP-enabled equipment are UPSs. This is for the obvious reason that UPSs are the most commonly used computer and network device power source used aside from commercial power. With the development and expansion of networks, network managers wanted the ability to monitor UPS parameters. RFC 1628, commonly referred to as the UPS MIB, was created to define objects commonly needed for managing UPS systems. The result is that UPS are being integrated low-level operating systems that controls the UPS and runs the agent-enabling software. There are other power sources that are categorized as SNMP energy equipment; however, these are limited to highly expensive, commercial use telecommunication power systems.

Depending on the particular power source, there can be a number of SNMP interface and intelligence systems available for use. This is heavily dependent on the popularity of the power source. For example, UPS and batteries are a very popular power sources used in networks. Consequently, there are vast amounts of SNMP agents and sensors that can be purchased commercially for them. Solar and wind power systems are growing heavily in use, and more and more users of those power sources seek to monitor and manage them remotely. One such example of an SNMP agent designed specifically for wind and solar application is the GreenMeter by WES Power Technologies, which is further discussed in the implementation section of this chapter. The availability of SNMP agents and sensors for solar and wind are limited, but are rapidly growing with the influx of demand.

UPS aside, the majority of power systems available do not possess the interface nor do they possess the intelligence to be incorporated directly into the network in terms of management. As energy networking matures, the directly coupling of energy systems to the network will become more of a reality. However, available technologies are mostly limited to power systems that do not possess those capabilities and enabling such capabilities through the use of probe interfaces to monitor device parameters.

#### **E. SNMP SYSTEM MANAGEMENT**

An architecture that will support the use of SNMP for managing network energy systems requires three essential tools: a management platform, a communications infrastructure, and interfaces to the energy equipment. By choosing to use SNMP, all management information communicated is translated into SNMP, which means that virtually any management platform can access and use the information. The management platform contains the management functions as well as the presentation functions used by network operators and administrators. By using SNMP, the information structure about the equipment is flexible enough that statistics and data of importance about the power system equipment can be polled. A communications infrastructure exists via the interoperability network that the node power system aims to support. However, an interface is necessary to bridge the gap between the physical parameters of the energy source(s) and being able to communicate those parameters to the management platform.

A variety of tools are available to provide the interface and intelligence to SNMP-enabled power system

devices. A variety of probes and sensors can be used for physical parameters such as temperature, humidity, liquid levels, airflow, current, voltage. In order to proceed, therefore, it must be known what devices and device parameters are desired.

#### **F. IMPLEMENTATION OF SNMP IN ENERGY SYSTEM MANAGEMENT**

As discussed in Chapter IX, a likely power system solution for remote network nodes would consist of a wind turbine generator, a photovoltaic array, and battery. Figure 17, located within Chapter IX, illustrates the electrical equivalency of such a system. There are hardware devices designed to accommodate hybrid power systems just like the one discussed here. An example of one such device, shown in Figure 20, is the GreenMeter built by WES Power Technologies.

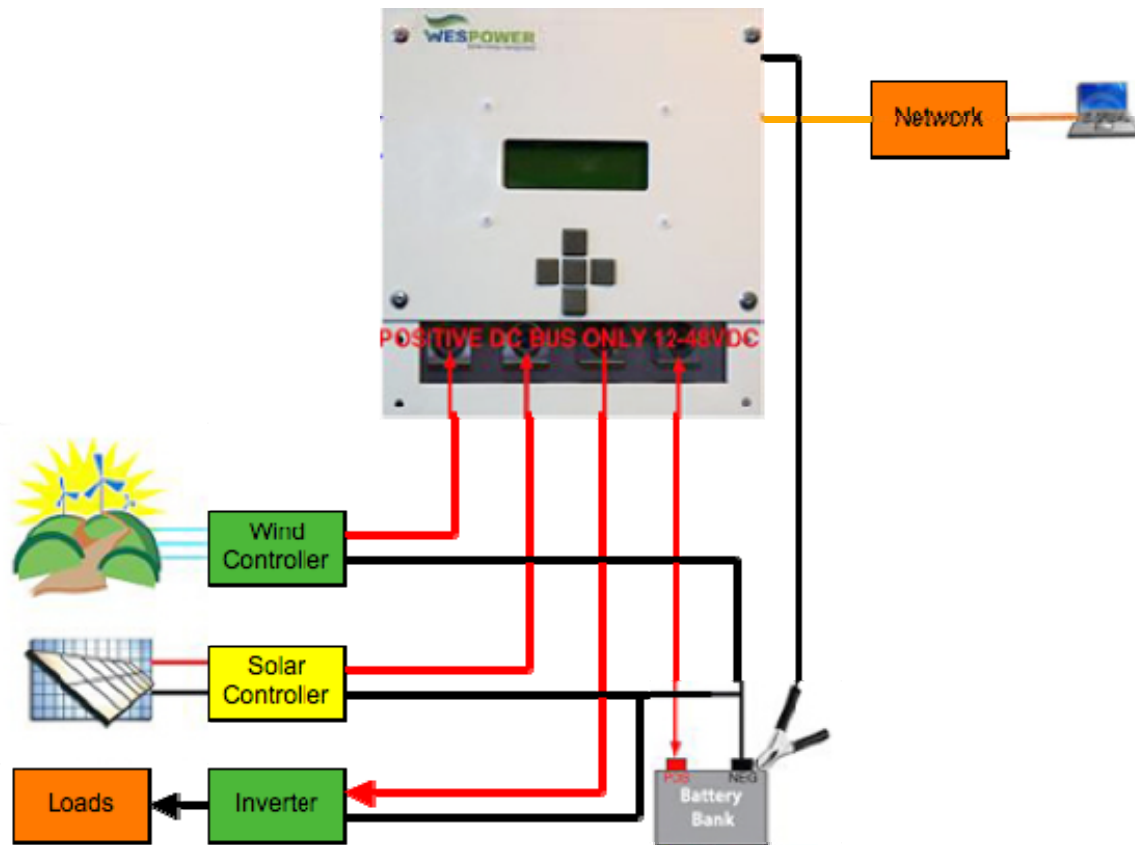

Figure 20. Simplified Wiring Schematic for the GreenMeter by WES Power Technologies. (Adapted From: WES Power Technologies)

Such a solution will afford the ability to monitor several parameters and notifications encompassing each of the devices (wind turbine, solar panels, battery, etc.) in the hybrid power system. The GreenMeter SNMP agent performs its task by sensing individual power device parameters at their respective charge controllers. NMSs on the network can deliver their get and trap messages directly from the GreenMeter (SNMP agent). Processing of the SNMP messaging and physical data collection is performed within the GreenMeter. The quality of such a solution is that data to and from the GreenMeter, via the network, is strictly in SNMP message formatting. However, an elaborate device such

as this will cost several hundreds of dollars because of the relatively low number of market competitors.

There are, however, a good number of probes and sensors designed to monitor batteries. In this particular power system, much about the state of the system can be determined by observing the state of the battery. For instance, rather than monitoring the wind generator or solar panels directly, the rate of battery charge or discharge can implicitly describe the state of the other power sources. For a fraction of the cost, a device designed to monitor physical parameters, non-specific to hybrid power systems, can be purchased. Devices such as the SensorProbe product line by AKCP Inc. is designed for use with a range of sensors for temperature, humidity, airflow, AC or DC voltage, or current flow. Just as the GreenMeter does, physical data collection and SNMP message processing occurs directly within the SensorProbe device. So again, all data traffic to and from the SensorProbe over the network is in SNMP messaging format. The major difference being that the GreenMeter is designed specifically for hybrid power system applications; whereas the SensorProbe is designed for use with certain power and non-power related applications in mind. The commonality of such devices makes them much more available and more affordable. Figure 21 depicts a functional schematic for using these devices in a network application.



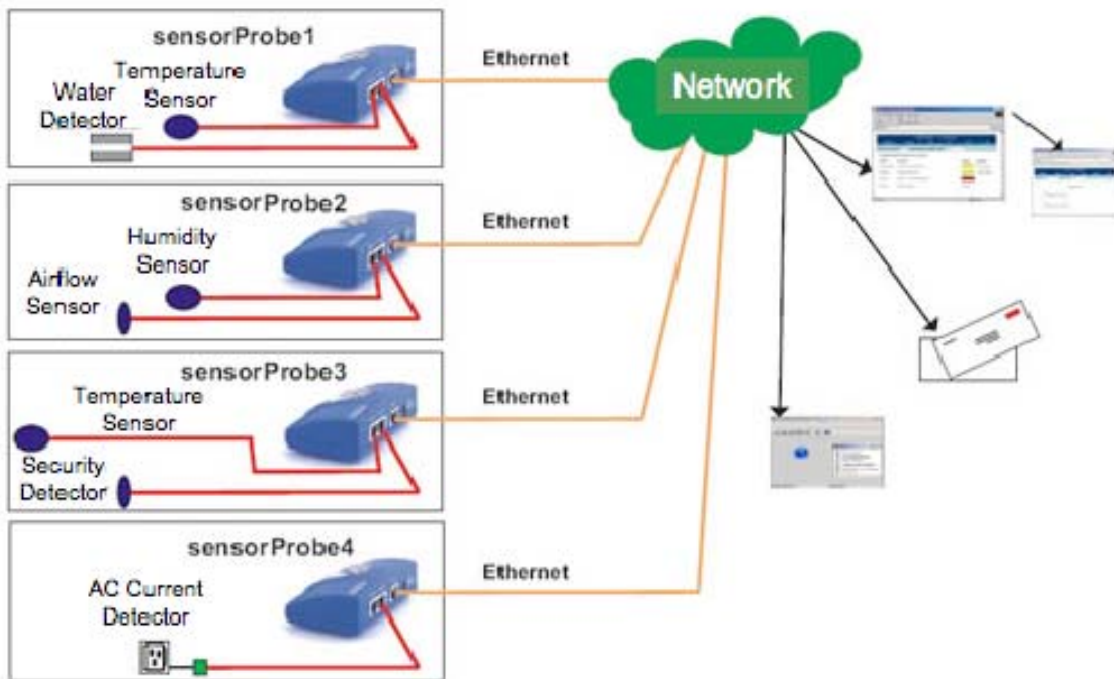

Figure 21. Implementation Diagram for various sensors and probes in a network application. (Adapted From: AKCP Inc.)

A starting point for implementing a SNMP agent, such as the SensorProbe, into the node's power system would be to incorporate a DC voltage sensor at the storage battery. The DC voltage sensor can be used to obtain the battery's voltage (in absolute value or percentage capacity) as well as alert NMSs to critical conditions, such as a low charge or critically low charge state. Through the use of predetermined data about the battery's normal, high, and low (or depleted) charge values, the state of the battery charge can be used to determine if and how the battery's charge is being utilized, as well as preemptively notify system managers of an impending loss of system power. RFC 1628 (UPS MIB) references several additional objects that can be used in managing the battery of a power system.

If more information specific to other power equipment, such as the wind generator or solar cells, is desired, additional voltage detectors can be used to detect the presence or absence of line voltages from those devices. These could be used to monitor and alert to the operation of lack of operation of these power-generating pieces of equipment. It would be prudent to incorporate these sensors at the output of the device prior to its controller. This would ensure that it is the power generating device being monitored and not the operation of the controller. The frequency and thresholds for monitored parameters greatly depends on the response time required to properly react to or prepare for system casualties. Since these are configuration variables and not design variables, they can be manipulated for application uniqueness.

Selection of the tools and technologies to use in remotely monitoring power system devices ultimately depends on system requirements and acquisition restraints. It is important to ensure that the means for monitoring those devices is through the implementation of SNMP. By using SNMP technologies to perform this task, the network and its systems are better suited to meet the overall scalable, distributed, and integrated network requirements. Additionally, SNMP is likely the protocol of choice for managing the network devices and equipment, thus making it the logic choice for managing network node power system components as well.

THIS PAGE INTENTIONALLY LEFT BLANK

## **XI. CONCLUSIONS AND RECOMMENDATIONS**

### **A. SUMMARY**

Numerous available power supply technologies can be considered. Many have been discussed to varying extents in this thesis, but it is by no means an exhaustive list. Each technology carries a multitude of advantages and disadvantages, which may either make it an excellent candidate or eliminate it from consideration. Understanding the user and system requirements will likely narrow the search for any given system.

In this scenario, for the powering of a remote telecommunications node, the best solution was made clear through the analysis of all available power sources. Ultimately a solar-wind hybrid system with the incorporation of battery and/or thermoelectric technologies was the best solution.

### **B. CONCLUSIONS**

The objective of this thesis was to develop a generic starting point for the design of a high-availability power system for any remote telecommunications node. A fundamental starting point is what is needed for actual design and implementation of this type of system. This is because it is evident that through the analysis of various technologies and the selection of best-fit solutions that there is no one-size-fits-all system. After investigating various combinations of technology and alternative power sources, some conclusions can be drawn with a fair amount of confidence.

One thing that has been determined is that a solar-wind hybrid power system with battery and/or TEG backup, while not the only solution, is one of the better solutions. Virtually any power system could technically work but the solution presented in this thesis provides the best all around solution and has the greatest impact on the improvement of operational availability. This conclusion is reached by taking into consideration the factors of load requirements, system reliability, economic feasibility, and usability in a variety of locations. That being said, a vital aspect to the success of this type of hybrid system is an accurate site analysis.

While the system size is ultimately independent of the fundamental system design, it is integral to having an adequate source of power. The basic system components can be scaled, in terms of quantity and configuration, for the site needs. This is where a site analysis comes into play by helping to develop an appropriately sized system. The majority of this analysis involves environmental data. Due to the maturity of solar and wind technologies, this sort of required data has been collected for years and is readily available from numerous locations world wide. The difficulty comes into play when considering the anticipated system users.

This system is being considered for use by local government first responders in a disaster situation or for military operations in remote regions. For this type of situation, it may not be known in advance the specific location the system will be needed. Even if it were, it is not economically viable to design individual systems for

every possible scenario. It is likely that the most reasonable solution is to develop regional-specific systems. This may not result in the optimal solution, but by making intelligent decisions and designing a system with some conservatism, it would maximize the effectiveness of the system for a multitude of locations and operations.

Even by developing systems catered by region, there are a few other factors to keep in mind when designing a system. One aspect to keep in mind is incorporating a commonality of components. This accomplishes a few important things. First, by utilizing a base set of components, it creates a common knowledge base. This enables users or maintenance activities to be successful at any location without having to learn location/application specific skill sets. Common components also allow for interchangeability and scalability. Such that, if a particular location is not generating sufficient power, more solar panels or wind turbines can be easily incorporated into the system without worry of incompatibility. The last factor this commonality promotes is in the monitoring and management aspect of the system.

If components used to construct power systems are different between sites and/or regions, then there is no guarantee that any one monitoring and management system will be able to communicate with all systems. By utilizing similar controllers and fault-monitoring systems, in addition to common power components, the efficiency and effectiveness of the entire system is maximized. Individually, power technologies will continue to advance and improve just as the network related monitoring and

management technologies will continue to advance. The key to improving these technologies together is by advancing the efforts in the integration of these subsystems. Not only will this improve overall system capabilities, but more importantly it addresses one of the fundamental principles in improving operational availability.

### **C. RECOMMENDATIONS FOR FUTURE RESEARCH**

This project identified various solutions for the powering of a remote telecommunications node. The best-fit solutions were identified to ensure maximum reliability and autonomy of the system utilizing current technology. In addition to this, analytical techniques were introduced to assist in the sizing of power components for system design. However, this paper does not discuss all aspects of system design and implementation. The authors subsequently make the following recommendations for future research areas:

- As ultra-capacitor technology advances, investigate the potential for battery replacement with ultra-capacitor storage systems. Additionally, determine the feasibility of designing current systems such that a UC bank can be seamlessly swapped with a battery bank, with minimal affect on the system.
- As fuel cell technology advances, investigate the potential for fuel cell utilization as a secondary power source.
- Verify system design by assessing performance in various site locations, under operational conditions.

- Develop a universal controller, with an embedded SNMP-agent, for use as a monitoring and control system.
- Evaluate the long-term benefits and cost savings when compared with alternative remote power systems.
- Evaluate the costs and feasibility of system acquisition for civil and military organizations.
- Generate an organization management and acquisition plan for developing, implementing, and advancing the monitoring and power system technologies and the integration of those technologies.

Due to the potential level of benefit from some of these future areas, specifically with respect to UCs and FCs, this may impact the decision-making process for those responsible for implementing a system of this nature. In order to promote the incorporation of future technologies, those charged with the responsibility of promoting and funding these types of projects must be proactive and foreseeing to prevent such reactionary response.

It is important for decision-makers to anticipate problems and solutions rather than react to them. By gaining a base understanding of these types of solutions, we need to inform decision makers of the benefits of proceeding with research and development, and the consequences of forgoing such. Pushing for organizations to start budgeting and planning for these systems early will ultimately result in better-designed systems, which are more coordinated



between local government agencies and military organizations, and be better suited to adapt to future possibilities.

This may also lead to companies that deal in these technologies to start to develop future technology solutions more suited to the respective organizational needs. Just as the example in Chapter VII, the company is developing the PEMFC laptop using technology catered for military use. The research and development of this technology was most likely initiated by the need and funding of the customer, rather than a company marketing initiative. The same thing could be done with respect to FC development for a remote telecommunications node. Future capabilities should not trump the needs for a well-designed system, but technology moves at such a rapid pace that it is important to always look ahead.

## LIST OF REFERENCES

- Aabakken, J., ed. 2006. *Power Technologies Energy Data Book*. 4<sup>th</sup> ed. National Renewable Energy Laboratory.
- Ahmed, Nabil A., Masafumi Miyatake, and A.K. Al-Othman. 2009. Hybrid Solar Photovoltaic/Wind Turbine Energy Generation System with Voltage-based Maximum Power Point Tracking. *Electric Power Components and Systems* 37: 43-60.
- Ahmed, Nabil A., Masafumi Miyatake, and A.K. Al-Othman. 2008. Power Fluctuations Suppression of Stand-Alone Hybrid Generation Combining Solar Photovoltaic/Wind Turbine and Fuel Cell Systems. *Energy Conversion and Management* 49: 2711-2719.
- Ahson, Syed and Mohammad Ilyas, eds. 2007. *WiMAX: Applications*. CRC Press.
- Almqvist, L. and R. Wikstrom. 1994. Standardizing Energy Management by Using Simple Network Management Protocol. Paper presented at international meeting for the Telecommunications Energy Conference, October 30 - November 3.
- American Wind Energy Association, comp. 2001. *Wind Energy Applications Guide*. American Wind Energy Association.
- Baschuk, J.J. and Xianguo Li. 2001. Carbon Monoxide Poisoning of Proton Exchange Membrane Fuel Cells. *International Journal of Energy Research* 25: 695-713.
- Battery and Energy Technologies. The Electropaedia. <http://www.mpoweruk.com/performance.htm> (accessed February 4, 2009).
- Battery Configuration Chart. Sundance Solar. <http://store.sundancesolar.com/bacoch.html> (accessed January 30, 2009).
- Borowy, Bogdan S. and Ziyad M. Salameh. 1996. Methodology for Optimally Sizing the Combination of a Battery Bank and PV Array in a Wind/PV Hybrid System. *IEEE Transactions on Energy Conversion* 11: 367-375.

- Cells, Modules & Arrays. Florida Solar Energy Center.  
[http://www.fsec.ucf.edu/en/consumer/solar\\_electricity/basics/cells\\_modules\\_arrays.htm](http://www.fsec.ucf.edu/en/consumer/solar_electricity/basics/cells_modules_arrays.htm)  
(accessed February 17, 2009).
- Crompton, Roy, ed. 2000. *Battery Reference Book*. Newnes.
- Diesel Engine. Britannica Student Encyclopaedia.  
<http://student.britannica.com/eb/art/print?id=19423&articleTypeId=0>  
(accessed November 20, 2008).
- Galdi, V., A. Piccolo, and P. Siano. 2009. Exploiting Maximum Energy from Variable Speed Wind Power Generation Systems by Using an Adaptive Takagi-Sugeno-Kang Fuzzy Model. *Energy Conversion and Management* 50: 413-421.
- GreenMeter Hybrid Energy Monitor. WesPower Power Technologies.  
<http://secure.netsolhost.com/wespt.com/GreenMeter/index.php> (accessed March 2, 2009).
- Grigsby, Leonard L. ed. 2007. *Electrical Power Engineering Handbook*. 2<sup>nd</sup> ed. CRC Press: Taylor & Francis Group.
- Hoogers, Gregor, ed. 2003. *Fuel Cell Technology Handbook*. CRC Press.
- Introduction. Thermoelectrics.com.  
<http://www.thermoelectrics.com/go.html>  
(accessed January 12, 2009).
- Kaldellis, J.K. 2003. An Integrated Feasibility Analysis of a Stand-Alone Wind Power System, Including No-energy Fulfillment Cost. *Wind Energy* 6: 355-364.
- Kalogirou, S.A. and Y. Tripanagnostopoulos. 2006. Hybrid PV/T Solar Systems for Domestic Hot Water and Electricity Production. *Energy Conversion and Management* 47: 3368-3382.

- Kellogg, W.D., M.H. Nehrir, G. Venkataramanan, and V. Gerez. 1998. Generation Unit Sizing and Cost Analysis for Stand-Alone Wind, Photovoltaic, and Hybrid Wind/PV Systems. *IEEE Transactions on Energy Conversion* 13: 70-75.
- Kreith, Frank and D. Yogi Goswami, eds. 2008. *Energy Management and Conservation Handbook*. CRC Press: Taylor & Francis Group.
- Kreith, Frank and D. Yogi Goswami, eds. 2007. *Handbook of Energy Efficiency and Renewable Energy*. CRC Press: Taylor & Francis Group.
- Manolakos, D., G. Papadakis, D. Papantonis, and S. Kyritsis. 2004. A Stand-Alone Photovoltaic Power System for Remote Villages Using Pumped Water Energy Storage. *Energy* 29: 57-69.
- Mauro, Douglas R., and Kevin Schmidt. 2001. *Essential SNMP*. 2<sup>nd</sup> ed. O'Reilly.
- Miller, Mark A., and P.E. Miller. 1999. *Managing Internetworks with SNMP*. 3<sup>rd</sup> ed. Wiley, John & Sons, Inc.
- Network Management Systems. Breakthrough Ltd.  
<http://www.breakt.co.il/main/nms.html>  
(accessed February 12, 2009).
- Onar, O.C., M. Uzunoglu, and M.S. Alam. 2008. Modeling, Control and Simulation of an Autonomous Wind Turbine/Photovoltaic/Fuel Cell/Ultra-Capacitor Hybrid Power System. *Journal of Power Sources* 185: 1273-1283.
- Ozgener, Onder. 2006. A Small Wind Turbine System (SWTS) Application and its Performance Analysis. *Energy Conversion and Management* 47: 1326-1337.
- Rowe, D.M., ed. 1995. *CRC Handbook of Thermoelectrics*. CRC Press.

- Sabziparvar, Ali A. and H. Shetaee. 2007. Estimation of Global Solar Radiation in Arid and Semi-Arid Climates of East and West Iran. *Energy* 32: 649-655.
- sensorProbe2. AKCP Inc. <http://www.sensorprobe2.at> (accessed March 2, 2009).
- Sinclair, K. 2007. *How to Build a Small Wind Energy Business: Lessons from California*. National Renewable Energy Laboratory.
- Solar Energy Technologies Program. Energy Efficiency and Renewable Energy at the U.S. Department of Energy. <http://www1.eere.energy.gov/solar/> (accessed February 17, 2009).
- UltraCell XX25. UltraCell Corporation. <http://www.ultracellpower.com/sp.php?xx25> (accessed March 3, 2009).
- U.S. Department of Energy. 2008. *20% Wind Energy by 2030: Increasing Wind Energy's Contribution to U.S. Electricity Supply*. U.S. Department of Energy.
- U.S. Department of Energy. 2004. *High-Performance Home Technologies: Solar Thermal & Photovoltaic Systems*. U.S. Department of Energy.
- Valenciaga, Fernando and Paul F. Puleston. 2005. Supervisor Control for a Stand-Alone Hybrid Generation System Using Wind and Photovoltaic Energy. *IEEE Transactions on Energy Conversion* 20: 398-405.
- Wind & Hydropower Technologies Program. Energy Efficiency and Renewable Energy at the U.S. Department of Energy. <http://www1.eere.energy.gov/windandhydro/> (accessed February 17, 2009).
- Yang, Hongxing, Lin Lu, and Wei Zhou. 2007. A Novel Optimization Sizing Model for Hybrid Solar-Wind Power Generation System. *Solar Energy* 81: 76-84.

## INITIAL DISTRIBUTION LIST

1. Defense Technical Information Center  
Ft. Belvoir, VA
2. Dudley Knox Library  
Naval Postgraduate School  
Monterey, CA
3. Dr. Tom Housel  
Department of Information Sciences  
Naval Postgraduate School  
Monterey, CA
4. Rex Buddenberg  
Department of Information Sciences  
Naval Postgraduate School  
Monterey, CA
5. Chadrick J. Beidalah  
Naval Postgraduate School  
Monterey, CA
6. Aaron D. Coudray  
Naval Postgraduate School  
Monterey, CA
7. John M. Thorpe  
Naval Sub Base Pearl Harbor  
Pearl Harbor, HI