



Calhoun: The NPS Institutional Archive
DSpace Repository

Reports and Technical Reports

Faculty and Researchers' Publications

2016-09

Unmanned systems interoperability standards

Blais, Curtis L.

Monterey, California. Naval Postgraduate School

<https://hdl.handle.net/10945/50386>

This publication is a work of the U.S. Government as defined in Title 17, United States Code, Section 101. Copyright protection is not available for this work in the United States.

Downloaded from NPS Archive: Calhoun



Calhoun is the Naval Postgraduate School's public access digital repository for research materials and institutional publications created by the NPS community. Calhoun is named for Professor of Mathematics Guy K. Calhoun, NPS's first appointed -- and published -- scholarly author.

Dudley Knox Library / Naval Postgraduate School
411 Dyer Road / 1 University Circle
Monterey, California USA 93943

<http://www.nps.edu/library>

NPS-MV-16-001



NAVAL POSTGRADUATE SCHOOL

MONTEREY, CALIFORNIA

UNMANNED SYSTEMS INTEROPERABILITY STANDARDS

by

Curtis L. Blais

September 2016

Approved for public release; distribution is unlimited

Prepared for: Office of the Secretary of Defense Joint Ground Robotics Enterprise
3090 Defense Pentagon, Room 5C756, Washington, DC 20301

THIS PAGE INTENTIONALLY LEFT BLANK

REPORT DOCUMENTATION PAGE			<i>Form Approved</i> OMB No. 0704-0188		
Public reporting burden for this collection of information is estimated to average 1 hour per response, including the time for reviewing instructions, searching existing data sources, gathering and maintaining the data needed, and completing and reviewing this collection of information. Send comments regarding this burden estimate or any other aspect of this collection of information, including suggestions for reducing this burden to Department of Defense, Washington Headquarters Services, Directorate for Information Operations and Reports (0704-0188), 1215 Jefferson Davis Highway, Suite 1204, Arlington, VA 22202-4302. Respondents should be aware that notwithstanding any other provision of law, no person shall be subject to any penalty for failing to comply with a collection of information if it does not display a currently valid OMB control number. PLEASE DO NOT RETURN YOUR FORM TO THE ABOVE ADDRESS.					
1. REPORT DATE (DD-MM-YYYY) 30-09-2016		2. REPORT TYPE Technical Report		3. DATES COVERED (From-To) 8 Oct 2015 – 30 Sep 2016	
4. TITLE AND SUBTITLE Unmanned Systems Interoperability Standards			5a. CONTRACT NUMBER		
			5b. GRANT NUMBER		
			5c. PROGRAM ELEMENT NUMBER		
6. AUTHOR(S) Curtis L. Blais			5d. PROJECT NUMBER		
			5e. TASK NUMBER		
			5f. WORK UNIT NUMBER RVJYM		
7. PERFORMING ORGANIZATION NAME(S) AND ADDRESS(ES) AND ADDRESS(ES) Naval Postgraduate School 1 University Circle Monterey, CA 93943			8. PERFORMING ORGANIZATION REPORT NUMBER NPS-MV-16-001		
9. SPONSORING / MONITORING AGENCY NAME(S) AND ADDRESS(ES) Secretary of Defense Joint Ground Robotics Enterprise 3090 Defense Pentagon, Room 5C756, Washington, DC 20301			10. SPONSOR/MONITOR'S ACRONYM(S)		
			11. SPONSOR/MONITOR'S REPORT NUMBER(S)		
12. DISTRIBUTION / AVAILABILITY STATEMENT Distribution Statement A. Approved for public release. Distribution is unlimited.					
13. SUPPLEMENTARY NOTES					
14. ABSTRACT Over the past several years, there has been rapid growth in the development and employment of unmanned systems in military and civilian endeavors. Some military organizations have expressed concern that these systems are being fielded without sufficient capabilities to interoperate with existing systems. Despite recognition of this requirement, interoperability efforts remain diverse and disjointed across the United States and internationally. The Naval Postgraduate School (NPS), Monterey, California, was sponsored by the U.S. Office of the Secretary of Defense (OSD) Joint Ground Robotics Enterprise (JGRE) in Fiscal Year 2016 (FY16) to explore (1) enhancement of robotics education; (2) improved representation of robotic systems in combat simulations; and (3) interoperability standards for military robotics systems. This report discusses work performed in FY16 to identify current and emerging interoperability standards for unmanned systems, including interactions of robotic systems with command and control (C2) and simulation systems. The investigation included assessment of the applicability of standardization activities in the Simulation Interoperability Standards Organization (SISO) in its development of the Phase 1 Coalition Battle Management Language (C-BML) and currently in-progress Command and Control Systems - Simulation Systems Interoperation (C2SIM) standardization efforts. The report provides a recommended approach, standards, activities, and timetable for a cross-system communications roadmap.					
15. SUBJECT TERMS Unmanned systems, interoperability, autonomy, standards					
16. SECURITY CLASSIFICATION OF:			17. LIMITATION OF ABSTRACT	18. NUMBER OF PAGES 51	19a. NAME OF RESPONSIBLE PERSON Curtis Blais
a. REPORT U	b. ABSTRACT U	c. THIS PAGE U			19b. TELEPHONE NUMBER (include area code) 831-656-3215

Standard Form 298 (Rev. 8-98)
Prescribed by ANSI Std. Z39.18

THIS PAGE INTENTIONALLY LEFT BLANK

**NAVAL POSTGRADUATE SCHOOL
Monterey, California 93943-5000**

Ronald A. Route
President

Steven Lerman
Provost

The report entitled “Unmanned Systems Interoperability Standards” was prepared for and funded by the Office of the Secretary of Defense Joint Ground Robotics Enterprise.

Further distribution of all or part of this report is authorized.

This report was prepared by:

Curtis L. Blais
Faculty Associate - Research

Reviewed by:

Imre Balogh, Director
MOVES Institute

Released by:

Jeffrey D. Paduan
Dean of Research

THIS PAGE INTENTIONALLY LEFT BLANK

TABLE OF CONTENTS

I. INTRODUCTION.....	9
A. BACKGROUND	9
B. OBJECTIVES	10
C. UNMANNED SYSTEM INTEROPERABILITY	11
D. ORGANIZATION OF THIS REPORT	12
II. STANDARDS FOR UNMANNED SYSTEM INTEROPERABILITY.....	15
A. INTRODUCTION.....	15
B. JOINT ARCHITECTURE FOR UNMANNED SYSTEMS.....	16
C. NATIONAL INFORMATION EXCHANGE MODEL	17
D. UNMANNED AIRCRAFT SYSTEM (UAS) CONTROL SEGMENT (UCS) ARCHITECTURE	19
E. FUTURE AIRBORNE CAPABILITY ENVIRONMENT.....	20
F. JOINT COMMON UNMANNED SYSTEM ARCHITECTURE.....	21
G. STANAG 4586: STANDARD INTERFACES OF UAV CONTROL SYSTEM (UCS) FOR NATO UAV INTEROPERABILITY.....	22
H. ADVANCED EXPLOSIVE ORDNANCE DISPOSAL ROBOTICS SYSTEM 23	
I. MULTILATERAL INTEROPERABILITY PROGRAMME	24
J. COMMAND AND CONTROL SYSTEMS - SIMULATION SYSTEMS INTEROPERATION.....	25
K. SUMMARY	28
III. INPUTS TO THE UNMANNED SYSTEMS INTEROPERABILITY ROADMAP.....	29
A. INTRODUCTION.....	29
B. UNMANNED SYSTEMS ROADMAP	29
1. Trust: Applying Ethical Constraints to Unmanned System Missions	30
2. Interoperability: Model-Based Systems and Software Engineering Framework	32
3. Operating Environment: Missions/Domains and Key Technologies	34
4. Human-Machine Interface: Manned/Unmanned Teaming	36
IV. SUMMARY AND RECOMMENDATIONS.....	39
A. SUMMARY	39
B. RECOMMENDATIONS.....	39
APPENDIX A. GLOSSARY OF TERMS AND ACRONYMS	41
LIST OF REFERENCES	45
INITIAL DISTRIBUTION LIST	49

THIS PAGE INTENTIONALLY LEFT BLANK

LIST OF FIGURES

Figure 1. Tri-lateral data interchange using a battle management language (from (Heffner and Hassaine 2010)).....	27
---	----

THIS PAGE INTENTIONALLY LEFT BLANK

I. INTRODUCTION

A. BACKGROUND

¹Over the past several years, there has been rapid growth in the development and employment of unmanned systems in military and civilian endeavors. Some military organizations have expressed concern that these systems are being fielded without sufficient capabilities to interoperate with existing systems. Several organizations in the United States and internationally have developed or are developing standards to address these concerns. The number of organizations involved and the diversity of standardization activities make it difficult to see the full extent of what is available and what is in progress. The United States Department of Defense (DoD) Unmanned Systems Integrated Roadmap FY2013-2038 identified interoperability as one of the principal needs in improving the use of unmanned systems (Department of Defense 2013): “the systems and technologies currently fielded to fulfill today’s urgent operational needs must be further expanded ... and appropriately integrated into Military Department programs of record (PoR) to achieve the levels of effectiveness, efficiency, affordability, commonality, *interoperability* [emphasis mine], integration, and other key parameters needed to meet future operational requirements.” The combination of interoperability (inter-platform challenge) and modularity (intra-platform challenge) tops the list of technologies that are key “to enhance capability and reduce cost” (p 28): “Interoperable interfaces for enhanced modularity and cross-domain data sharing present an opportunity to minimize future lifecycle costs, reduced force structure requirements, and adapt rapidly to changing threats or new available technologies.” Despite recognition of this requirement, interoperability efforts remain diverse and disjointed.

The Naval Postgraduate School (NPS), Monterey, California, was sponsored by the U.S. Office of the Secretary of Defense (OSD) Joint Ground Robotics Enterprise (JGRE) in Fiscal Year 2016 (FY16) to explore (1) enhancement of robotics education; (2) improved representation of robotic systems in combat simulations; and (3) interoperability standards for military robotics systems. The JGRE is the principal

¹ Much of the material in this report first appeared in (C. L. Blais 2016) prepared for and presented at the 2016 Simulation Innovation Workshop in September 2016. The content of this report provides some elaboration and reorganization of the content of the original paper.

organization in DoD for providing oversight, policy, and program direction to establish definitive robotics operational requirements and to pursue critical technologies to satisfy those requirements. The organization focuses on interoperability, modeling and simulation, and test and evaluation.

This report discusses work performed in FY16 to identify current and emerging interoperability standards for unmanned systems, including interactions of robotic systems with command and control (C2) and simulation systems. The investigation included assessment of the applicability of standardization activities in the Simulation Interoperability Standards Organization (SISO) in its development of the Phase 1 Coalition Battle Management Language (C-BML) (Simulation Interoperability Standards Organization 2014) and currently in-progress Command and Control Systems - Simulation Systems Interoperation (C2SIM) standardization efforts. The results reported here provide a recommended approach, standards, activities, and timetable for a cross-system communications roadmap. However, we recognize that during the period of performance of this work, DoD has initiated a new roadmap activity. Coordinators of that work have put out a call for contributions, to which a number of NPS faculty and project collaborators responded. It is hoped that the inputs offered, together with the findings of the NPS JGRE project, will prove useful in preparation of the new roadmap.

B. OBJECTIVES

In a guest editorial in the *Modeling and Simulation Journal*, Mr. Stephen P. Welby, Deputy Assistant Secretary of Defense (Systems Engineering), stated the following:

“Common and shared technical standards provide the foundation and basis that allow modeling and simulation tools to be efficiently and effectively deployed and scaled to address enterprise challenges. ... I believe technical standardization activities play a critical role in improving the Department’s effectiveness in weapon systems acquisition and sustainment. Technical standards are an enabler to the Department’s larger goals of interoperability, improved operational readiness, and reduced total ownership costs between and among the Services, other Agencies, industry, and our allies. Technical standards provide the corporate process memory needed for a disciplined systems engineering approach and help ensure that the government and its contractors understand the critical processes and practices necessary to take a system from design to production, and through sustainment.” (Welby 2013, 2-3)

While relating these comments to the modeling and simulation community, the argument applies equally well to the unmanned system arena, particularly relating to interoperability, operational readiness, and reduced costs. In light of this Departmental concern, the objectives of this project are to research current and emerging unmanned system interoperability standards activities and to provide inputs to DoD preparation of a new unmanned system roadmap.

C. UNMANNED SYSTEM INTEROPERABILITY

The National Institute for Standards and Technology (NIST) defines interoperability as:

“The ability of software or hardware systems or components to operate together successfully with minimal effort by the end user. Further attributed with functional, behavioral, lifecycle, and architectural scopes, and, therefore, can be delineated in terms of control and can be categorized into levels, types, or degrees in application programs. Facilitated by common or standard interfaces.” (National Institute of Standards and Technology 2008, 28)²

The Unmanned Systems Integrated Roadmap document references (Unmanned Interoperability Initiative 2012) in defining interoperability as:

“The ability of systems, units, or forces to provide services to and accept services from other systems, units, or forces and to make use of the services, units, or forces; and to use the services so exchanged to enable them to operate effectively together. An example of the use of this policy would be the condition achieved among communications-electronics systems or items of communications electronics equipment when information or services can be exchanged directly and satisfactorily between them and/or their users.” (Department of Defense 2013, 32)

The accepted definition of M&S interoperability in the M&S community is similar to the Roadmap definition of interoperability above:

“The ability of a model or simulation to provide services to and accept services from other models and simulations, and to use the services so exchanged to enable them to operate effectively together.” (Department of Defense 2010, 155)

² The NIST publication references (Institute of Electronic and Electrical Engineers 2000) and (Headquarters of the Department of the Army 2004) in its definition of interoperability.

Interoperability can apply to internal system components (intra-system, or component-level interoperability)—this is both a physical and logical interconnection—as well as external interactions among multiple systems (inter-system), which is an information-centric interconnection. For example, with regard to intra-system interoperability, the Advanced Explosive Ordnance Disposal Robotics System (AEODRS) framework requires specific standards for physical connections (e.g., power) and logical connections (e.g., information) between components. The Unmanned System Integrated Roadmap states its interoperability focus as concerning “critical interfaces within the overall UAS [unmanned aircraft system] architecture by implementing standard IOPs [interoperability profiles] ... [to] define the communications protocols, message formats, and implementation methods across these interfaces for new start efforts and system upgrades” (Department of Defense 2013, 34). For purposes of this study and report, we focused on the information-centric interconnections, whether intra-system or inter-system (the physical interconnections are important, but fall under a different set of standards and, generally, a different group of standards bodies than our principal areas of experience and current involvement). Nonetheless, it is recommended that any future unmanned system interoperability standardization roadmap for DoD address both physical and logical (information) interconnections.

D. ORGANIZATION OF THIS REPORT

This report presents objectives and findings of NPS project work in FY16 relating to interoperability standards for unmanned systems. The report discusses current and emerging interoperability standards for unmanned systems, including the role played by the Simulation Interoperability Standards Organization (SISO) in its development of the C-BML Phase 1 standard and current C2SIM standardization activities working on the next-generation standard for data interchange across command and control (C2) systems, simulation systems, and robotics systems³. Chapter 1 introduced the work and provided a general discussion of unmanned system interoperability requirements. Chapter 2 describes several interoperability efforts relevant to the unmanned systems

³ We use the terms “robotics systems” and “unmanned systems” somewhat interchangeably throughout the report. We refer the reader to the National Institute of Science and Technology Special Publication 1011-I-2.0 (National Institute of Standards and Technology 2008) for definition of these and other relevant terms.

community (meant to be illustrative, not exhaustive, within the time and level of effort constraints of this project), including relevant standardization activities in SISO and the role the organization could play in standardization of unmanned system interoperability. Chapter 3 describes current DoD efforts to produce an updated unmanned systems roadmap and inputs offered by NPS faculty for that effort. Chapter 4 provides a summary and set of recommendations for consideration in moving forward from the current state of the art. A glossary of acronyms and abbreviations and list of references are provided at the end of the report.

THIS PAGE INTENTIONALLY LEFT BLANK

II. STANDARDS FOR UNMANNED SYSTEM INTEROPERABILITY

A. INTRODUCTION

This chapter provides a survey of several initiatives relevant to interoperability standards and best practices for unmanned systems.⁴ The Unmanned System Integrated Roadmap referenced earlier identifies the following DoD initiatives working to increase interoperability and modularity, indicating that these “will require technological advances and cooperation among DoD, governmental agencies, and industry” (Department of Defense 2013, 33)⁵:

- Unmanned Interoperability Initiative (UI2) Capability-Based Assessment (Unmanned Interoperability Initiative 2012)
- Standards and Governance Efforts
- Unmanned Aircraft System (UAS) Control Segment (UCS) Architecture (Unmanned Aircraft System (UAS) Control Segment (UCS) Working Group n.d.)
- Unmanned Systems Interoperability Profiles (USIPs); e.g., see (Department of Defense 2008) and discussion in (Department of Defense 2013)
- Service Interface Control Working Groups (ICWGs)
- Service Interoperability Profiles (IOPs); e.g., see (FisherKeller 2014)
- DoD Chief Information Office Interoperability Steering Group (Department of Defense 2012)
- Joint Interoperability Test Command (JITC) (Joint Interoperability Test Command n.d.)
- Joint Technology Center/Systems Integration Laboratory (JSIL) (Aviation and Missile Research, Development, and Engineering Center n.d.)
- DoD IT Standards and Profile Registry (DISR, see (Department of Defense 2015))
- Future Airborne Capability Environment (FACE) (The Open Group n.d.) (Matthews and Sweeney 2013)
- Sensor/Platform Interface and Engineering Standardization (SPIES) Initiative (SAE International 2013)

⁴ Acknowledgement is given to project collaborator, Mr. William Sobotka, for assistance in gathering materials for this chapter.

⁵ The list also provides associated references to various online and documented resources to provide additional background information for the reader to investigate as desired.

- IOPs defined for Unmanned Ground Systems (UGS); e.g., (Robotic Systems Joint Project Office 2011)
- Advanced Explosive Ordnance Disposal Robotics System (AEODRS) Common Architecture (Del Signore 2015)
- Test and Evaluation Architecture and Bench Testing
- Geospatial Intelligence (GEOINT) Functional Manager Seal of Approval (GFMSA) (National System for Geospatial Intelligence 2013)

In the following sections, we identify and briefly describe several of the unmanned system interoperability efforts currently active in the community, including several identified above from the Unmanned Systems Integrated Roadmap. Our purpose in the following is to indicate the breadth of activities and variety of organizations involved in this area, without attempting to be exhaustive. For additional information, refer to the Roadmap document for information about areas of interest that are not discussed further herein, as well as activities of the Interoperability Integrated Product Team (I-IPT) discussed in the DoD Report to Congress on Addressing Challenges for Unmanned Aircraft Systems from December 2013 (Office of the Under Secretary of Defense for Acquisition, Technology and Logistics 2013).

B. JOINT ARCHITECTURE FOR UNMANNED SYSTEMS

The Joint Architecture for Unmanned Systems (JAUS), formerly known as Joint Architecture for Unmanned Ground Systems (JAUGS), was an initiative started in 1998 by the Office of the Under Secretary of Defense Acquisition, Technology, and Logistics (OUSD AT&L) Joint Robotics Program. The objective was to develop an open architecture for the domain of unmanned systems. The JAUS messaging architecture enables communication with and control of unmanned systems across the entire unmanned system domain.

JAUS provides a common language enabling internal and external communication between unmanned systems. It incorporates a component-based, message-passing architecture specifying data formats that promote the stability of capabilities by projecting anticipated requirements as well as those currently needed. JAUS addresses unmanned system capabilities including payload control, autonomous systems, and weapons systems.

In order to ensure that the component architecture is applicable to the entire domain of current and future unmanned systems, JAUS is built on five principles: vehicle platform independence; mission isolation; computer hardware independence; technology independence; and operator use independence. JAUS is open and scalable to the unmanned systems community's needs.

The JAUS Reference Architecture (JAUS 2007) defines a data format and methods of communication between computing nodes. The architecture dictates a hierarchical system built up of subsystems, nodes, and components, and contains a strictly defined message set to support interoperability. Significant portions of the architecture, including the definitions for subsystem, node, and component, have been loosely defined in order to accommodate the five principles on which the architecture is based.

The architecture has migrated from the JAUS Working Group, which was composed of individuals from the government, industry, and academia, to what was then the Society of Automotive Engineers (now, SAE International), Aerospace Division, Avionics Systems Division. The Aerospace Standards Unmanned Systems Steering Committee (AS-4) now maintains and advances the set of ad hoc standards.

C. NATIONAL INFORMATION EXCHANGE MODEL

The National Information Exchange Model (NIEM) is an Extensible Markup Language (XML)-based information exchange framework. NIEM represents a collaborative partnership of agencies and organizations across all levels of government (federal, state, and local) and with private industry, including recent activities with the international robotics community (Litwiller, Weber and Klucznik 2015) (Fedi and Nasca 2015). The purpose of the collaboration is to effectively and efficiently share critical information at key decision points throughout the justice, public safety, emergency and disaster management, intelligence, defense, and homeland security communities. NIEM is designed to develop, disseminate, and support enterprise-wide information exchange standards and processes that will enable jurisdictions to automate information sharing.

An initial effort by the U.S. Department of Justice, called the Global Justice Information Sharing Initiative, set into motion the creation of a seamless, interoperable model for data exchange that could solve a range of information-sharing challenges

across a variety of government agencies. After a two-year effort, the first pre-release of the Global Justice XML Data Model (GJXDM) was announced in April 2003.

Parallel to the GJXDM effort was the stand-up of the U.S. Department of Homeland Security. The mention of metadata in the President's strategy for homeland security in the summer of 2002 (Office of Homeland Security 2002) initiated actions in the homeland security community to begin working towards standardization. The collaborative efforts by the Justice and Homeland Security Departments to produce a set of common, well-defined data elements for data exchange development and harmonization led to the beginnings of NIEM, which was formally launched in April 2005 by the Chief Information Officers of the U.S. Department of Homeland Security and the U.S. Department of Justice. In October 2010, the U.S. Department of Health and Human Services joined as the third steward of NIEM. More recently, NIEM has added a military operations domain to address information exchange requirements within DoD and between DoD and other agencies. The U.S. DoD has established a "NIEM-first" policy, requiring DoD programs to consider the use of NIEM for inter-system information exchange before adopting other means and methods.

NIEM is not a software program, database, network, or computer system. NIEM is a methodology designed to facilitate the creation of automated enterprise-wide information exchanges which can be uniformly developed, centrally maintained, quickly identified and discovered, and efficiently reused. Its adoption will enable more efficient and expansive information sharing between agencies and jurisdictions; more cost-effective development and deployment of information systems; improved operations; better quality decision making as a result of more timely, accurate, and complete information; and, as a consequence, enhanced public safety and homeland security.

NIEM enables information sharing, focusing on information exchanged among organizations as part of their current or intended business practices. The NIEM exchange development methodology results in a common semantic understanding among participating organizations and data formatted in a semantically consistent manner. The use of NIEM standardizes content for data exchange, while providing tools and managed processes.

References (Litwiller, Weber and Klucznik 2015) and (Fedi and Nasca 2015) describe the Simulated Interactive Robotics Initiative (SIRI), a recent project investigating the use of NIEM for inter-system interactions, specifically between a Robotic and Autonomous System (RAS) and a notional command and control (C2) system.

D. UNMANNED AIRCRAFT SYSTEM (UAS) CONTROL SEGMENT (UCS) ARCHITECTURE

The UAS Control Segment (UCS) architecture standard (SAE International n.d.) is designed to enable conformant services and applications to be seamlessly integrated and reused by any UAS control segment and other systems adhering to the standard. When the OUSD AT&L began development of the architecture in 2009, the goal was to break apart the traditional proprietary stove-piped acquisition approach and to create an open market for these services and applications. The net objective was to drive down life-cycle costs and provide enhanced interoperability. After ten very successful version releases, in April of 2015 AT&L transitioned sustainment of the UCS architecture to SAE International. AT&L had long sought to eventually transition the UCS architecture effort to an enduring organization (just as it had done previously with the JAUS effort) and felt the best organization to sustain the architecture was SAE.

UCS provides for three aspects of interoperability: (1) conceptual interoperability, addressing how things relate to each other; (2) pragmatic interoperability, addressing functional capabilities; and (3) semantic interoperability, addressing the meaning encoded into messages and data (Gregory 2016). The Conceptual Data Model (CDM) (the foundation for conceptual interoperability) comprises the resources in the RAS domain: vehicles, payloads, control stations, communications and their objectives, missions/tasks, data products, and environment. All information architectures must interact with the same real-world objects. UCS defines a Service Oriented Architecture (SOA) (the foundation for pragmatic interoperability) that provides an architectural paradigm for defining how people, organizations, and systems provide and use services to achieve results. In this context, a service is defined as a resource that enables access to one or more capabilities, where a capability is the ability to act and produce an outcome that achieves a result. Exchanged messages refer to the CDM and therefore are conceptually related. The SOA ties these messages to real-world effects/actions. UCS provides an extensive Logical Data

Model (LDM) (the foundation for semantic interoperability) which defines how the state values in message exchanges (e.g., vehicle position) are to be interpreted within a particular system. The LDM provides a machine-readable definition of state information and any required conversions between systems.

E. FUTURE AIRBORNE CAPABILITY ENVIRONMENT

Much like the initiation of the UCS architecture development effort, the Future Airborne Capability Environment (FACE) was also initiated to address the single vendor-single supplier acquisition problem. The traditional military aviation acquisition approach is to procure a system designed and developed for a unique set of requirements by a single vendor/supplier. Although this approach served Service Air Acquisition Program Offices well, it presented a host of follow-on problems including long lead procurement times, cumbersome improvement processes, and lack of hardware and software re-use between various aircraft platforms resulting in a platform-unique design. These all result in higher costs and the inability to deliver capabilities to the warfighter in a timely manner.

To counter these trends, the Naval Aviation Air Combat Electronics Program Office, enabled by the expertise and experience of the military aviation community's industrial base, adopted a revolutionary approach. FACE enables timely, affordable, cross-platform capability advancements based on fundamental software engineering principles and pragmatic, practical experience. FACE establishes a common computing architecture supporting portable, capability-specific software applications across military avionics systems. The approach employed by FACE is to develop a Technical Standard for a software capability designed to promote portability and create software product lines across the military aviation community. The FACE approach allows software-based capabilities to be developed as components that are exposed to other software components through defined interfaces. It also provides for re-use of software across different hardware computing environments.

The FACE strategy creates a software environment on the installed computing hardware of the aircraft (the platform) enabling FACE applications to be deployed on different platforms with minimal to no impact to the application. Provided the software interfaces of the FACE computing environment are recreated on computers residing on

other platforms, the FACE applications can be redeployed on other platforms achieving greater application portability and addressing interoperability issues.

FACE is being developed by The Open Group (The Open Group n.d.), a global consortium that enables the achievement of business objectives through Information Technology (IT) standards. With more than 400 member organizations, The Open Group has a diverse membership that spans all sectors of the IT community – customers, systems and solutions suppliers, tool vendors, integrators, and consultants, as well as academics and researchers.

F. JOINT COMMON UNMANNED SYSTEM ARCHITECTURE

The Joint Common Unmanned System Architecture (JCUA) is being developed to provide a common baseline, or reference architecture, for the comparison of multiple UAS systems and the technical characterization of interoperability gaps identified by the UAS Interoperability Initiative (UI2). Architecture documents from the major Service UAS PoRs were reviewed and compared against a common JCUA baseline. Differences in terminology, standards citations, content, and overall approach were documented to assess specific interoperability gaps, as well as capture overall engineering approaches at the Family of System (FoS) and System of Systems (SoS) levels.

All DoD PoRs are required to develop architecture documentation to support the Net Ready Key Performance Parameter (NR KPP) assessment required for milestone reviews. Most architecture documentation has previously been developed independently by each PoR with only general guidelines. Comparing different PoR documents is difficult due to the lack of common terms, frames of reference, and interfaces. Even fully interoperable interfaces cannot be identified from a review of the technical documentation. Extensive and expensive testing is typically required to ensure compliance with DoD standards. The JCUA is designed to support ongoing DoD and Service architecture efforts by developing compliant, unmanned system data products and architecture artifacts validated by DoD, Joint, and Service organizations in response to the objectives of the Chairman of the Joint Chiefs of Staff Instruction (CJCSI) 6212.01F NR KPP (Chairman of the Joint Chiefs of Staff 2012), CJCSI 3170.01I Joint Capabilities Integration and Development System (JCIDS) (Chairman of the Joint Chiefs of Staff 2015), and other relevant instructions and guidance.

JCUA Version 1.0 captures the current analytical status of architecture documentation to support future coordination across DoD stakeholders. Coordination with authoritative sources, including the Chief Information Office (CIO), Service PoRs, and other information producers such as the Joint Architecture Federation and Integration Project (JAFIP), the Joint Mission Thread Architecture and Testing Working Group (JMTAT WG), and joint DoD Architecture Framework (DODAF) AV-2 (“all view,” integrated dictionary) efforts will establish a common UAS information exchange baseline which will be published as JCUA Version 2.0. JCUA Version 2.0 also will include standard terminology and DoD guidance to include the UCS architecture, the North Atlantic Treaty Organization (NATO) Standardization Agreement (STANAG) 4586, and other applicable guidance and directives. This version will contain traceability back to original PoR architectures to support the rapid incorporation of common terminology and information descriptions in individual system architectures.

JCUA is under development by the Horizontal Integration Working Group (HIWG) within the OUSD AT&L Unmanned System Warfare Office.

G. STANAG 4586: STANDARD INTERFACES OF UAV CONTROL SYSTEM (UCS) FOR NATO UAV INTEROPERABILITY

Because coalition UAVs are designed, developed, and procured “nationally”, they comprise system elements and functions that are generally unique to that nation as well as being generally vehicle-specific. The result is a variety of non-interoperable “stovepipe” vehicles and systems. To address this issue, the NATO STANAG 4586 (North Atlantic Treaty Organization 2012) was developed to provide a level of unmanned aerial vehicle (UAV) interoperability across coalition forces to allow for the ability to quickly task available assets, to mutually control these vehicles and their payloads, and to rapidly disseminate tactical information to the collective force as required. STANAG 4586 development work began in 1999 when a NATO working group was formed to begin defining a standard to meet identified goals of interoperability between UAV assets. At that time the working group represented 8 nations and representatives from more than 20 different companies. There are now more than 15 nations included in the effort. Since the first edition was completed in 2003, the STANAG has evolved through the compilation of lessons learned and ever-maturing operational requirements. Edition 3 was completed in 2012.

STANAG 4586 specifies interfaces to be implemented to achieve the level of interoperability (LOI) that is operationally required per each respective UAV concept of operations (CONOPS). This can be achieved by implementing standard interfaces in the UCS to communicate with different UAVs and their payloads, and with different C4I systems. STANAG 4586 precepts that are identified as mandatory must be implemented as a whole in order to effectively achieve the required LOI.

In large part, STANAG 4586 is an Interface Control Definition (ICD). It defines the architectures, interfaces, communication protocols, data elements, message formats, and related STANAGs that must be complied with in order to operate and manage multiple legacy and future UAVs. STANAG 4586 defines two critical interfaces: a Data Link Interface (DLI) and a Command and Control Interface (CCI). The DLI enables operations with legacy as well as future UAV systems; DLI messages are air vehicle and payload independent. The CCI enables payload data dissemination to support legacy and evolving NATO C4I systems and architectures and is Command, Control, Communications, Computers, and Intelligence (C4I) system/node independent.

H. ADVANCED EXPLOSIVE ORDNANCE DISPOSAL ROBOTICS SYSTEM

The Advanced Explosive Ordnance Disposal Robotics System (AEODRS) describes a common architecture for developing next-generation Explosive Ordnance Disposal (EOD) robotic systems. It began as a joint-Service effort with the Navy leading the program as the acquisition executive agent. The program was initiated in 2007 to replace the commercial-off-the-shelf (COTS) bomb disposal robots that were quickly rushed into theater at the outset of the Iraq War (in the U.S., many of these are now passed to law enforcement agencies through the DoD's 1033 program managed by the Defense Logistics Agency Law Enforcement Support Office). All four branches of the military have EOD teams and jointly contributed to drafting the AEODRS requirements. AEODRS specifies a robotic FoS based on size. The smallest weighs about 35 pounds and fits into a backpack. The next size weighs up to 165 pounds and will need to be transported in tactical trucks and carried short distances by a two-person team. The largest weighs about 750 pounds and is a large, vehicle-sized robot that will be towed by a trailer.

The full acquisition is occurring incrementally (Increments One, Two, and Three) based on the increase in weight and size as noted above. The system components are intended to “plug and play” and be interoperable via a standard interface. AEODRS Increment One is the first open architecture system joint EOD robot. The Increment One system comprises a handheld operator control unit; communications link; modules providing a mobility capability, master capability, power capability, manipulator capability, end effector capability, visual sensors capability, and autonomous behaviors capability; and other minor components. The acquisition approach is based on a government-owned architecture that uses common physical, electrical, and logical interfaces. This allows for a family of EOD unmanned ground robots with a high degree of interoperability and inter-changeability that permits rapid integration of new technologies across the FoS. The modular open systems architecture also enables industry to conduct independent research and development to provide innovative technology to the program at a component level.

The Naval Sea Systems Command (NAVSEA) announced in August 2015 a contract award for AEODRS Increment One integration and most recently the selected team successfully completed Critical Design Review (CDR) (Kreisher 2016) (note: the Army and Air Force have dropped out of the joint effort and are separately acquiring commercially available systems to meet their service requirements).⁶ NAVSEA also recently approved Milestone B for AEODRS Increment 2, which clears the way to move on to the engineering and manufacturing development phase.

I. MULTILATERAL INTEROPERABILITY PROGRAMME

The Multilateral Interoperability Programme (MIP) is a multi-national organization established by national command and control information systems developers for the purpose of sharing C2 information in a coalition operational environment (Multilateral Interoperability Programme n.d.). The MIP has a long history (over 30 years) of data specification and physical implementations to create an operational data-sharing capability. The MIP data model is promulgated by NATO as STANAG 5525, the Joint Consultation, Command and Control Information Exchange

⁶ Unfortunately, the Army and Air Force have dropped out of the joint effort and are separately acquiring commercially available systems to meet their service requirements. This has the danger of perpetuating interoperability problems across service-specific devices within DoD.

Data Model (JC3IEDM) (Multilateral Interoperability Programme 2012). The MIP Baseline 3.1 from 2014 is the currently endorsed version of the information model for exercises and deployments.

In the area of robotics, a search of the MIP site for terms such as “unmanned system” or “robot” brings up only one reference, Annex E-1 of the MIP Systems Level Test 3 from 26 May 2006, which actually refers to use of a test harness, not a physical robot. However, a search on the term “unmanned” produces several results. Scanning these, we find that the data model uses the term in certain enumerations (e.g., aircraft-type-manning code, to indicate if an aircraft is designed to be manned or unmanned, including remotely piloted; definition of an unmanned-aerial-vehicle airspace; unmanned sensors; unmanned mine clearing). Overall, though, there appears to be little in the MIP Information Model (MIM) specific to unmanned systems or robotics systems. There is sufficient generality in the data model to be used with unmanned systems, such as the actions, events, objects, and object types, but more can be done to make it directly applicable. In terms of international standardization, the key benefit of the MIP is that it already is a strong partnership in the area of C2 data interchange across a large number of countries. As shown in the SIRI work introduced earlier, C2 data interchange is an important part of the data interchange required for robotics systems.

J. COMMAND AND CONTROL SYSTEMS - SIMULATION SYSTEMS INTEROPERATION

The Simulation Interoperability Standards Organization (SISO) Command and Control Systems - Simulation Systems Interoperation (C2SIM) Product Development Group (PDG) is developing the next-generation international standard for information interchange across C2 systems, simulation systems, and robotics systems. It is a follow-on effort to the Coalition Battle Management Language (C-BML) Phase 1 standard approved by SISO in 2014 (Simulation Interoperability Standards Organization 2014). Specifically, the C-BML standard is described as “a standard language for expressing and exchanging plans, orders, requests, and reports across command and control (C2) systems, live, virtual, and constructive (LVC) modeling and simulation (M&S) systems, and autonomous systems participating in Coalition operations” (Simulation Interoperability Standards Organization 2014, 33).

The Phase 1 C-BML standard was strongly influenced by the JC3IEDM model. JC3IEDM enumerations and principal data types form the foundation of the XML schema files specified in the C-BML standard. These are now undergoing review and adoption, change, or removal as the current C2SIM PDG works on specifying a core logical data model for the next generation SISO standard. Operationally, with the goal of enabling data interchange across command and control system, simulation systems, and robotic systems, there are clear use cases for facilitating data exchange across the future C2SIM standard and current/evolving MIP data structures.

As introduced earlier in (Fedi and Nasca 2015) regarding the SIRI project, the authors describe a requirement for “tri-lateral interoperability” across RAS, C2 systems, and simulation systems, although admitting that their work to date with the SIRI project was focused on the RAS-C2 systems side of the “triangle” and that further work is needed to address the other sides of the “triangle” (Fedi and Nasca 2015, 79). The C-BML standard was explicitly designed to address all three sides of this triangle. Some of the special issues of interacting with robotics systems were raised during early stages of the C-BML standardization effort; e.g., see (Davis, Blais and Brutzman 2006) which considered the C-BML objectives in light of other data interchange approaches employed in the robotics field. In (Heffner and Hassaine 2010), the authors describe the need for a battle management language interface with unmanned systems and laid out an architectural approach intended to inform the STANAG 4586 effort in progress at the time. They defined three classes of interoperability: (1) intra-system interoperability (interoperability and interchangeability of robotic system components, as in the modularity challenge discussed in Section 1); (2) inter-system interoperability (information exchange across homogeneous or heterogeneous robotics systems); and (3) extra-system interoperability (information exchange between a robotic system and other non-robotic systems, as in the interchange with C2 and simulation systems). Their view of the “tri-lateral” interoperability described in (Fedi and Nasca 2015), but using a battle management language as the common interchange mechanism, is shown in Figure 1.

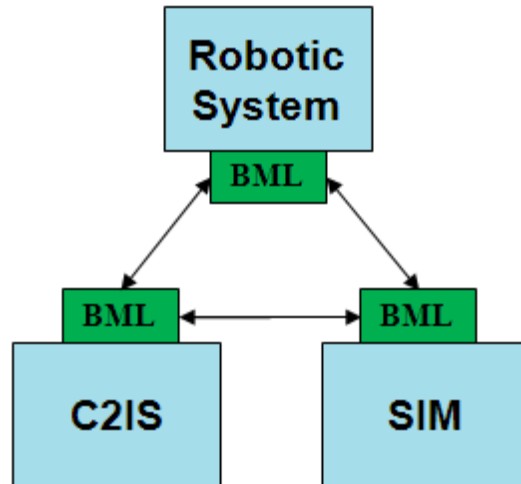

Figure 1. Tri-lateral data interchange using a battle management language (from (Heffner and Hassaine 2010))

One of the concerns expressed in early investigations was the lack of detailed tasking orders at the “tactical” level of the robotic system (i.e., control over actuators/effectors). In the current C2SIM standardization work, this deficiency can be addressed through identification of use cases in the robotics domain that will inform specification of logical data model content as a domain-specific component of the C2SIM standard. Immediate work can also involve extension of C-BML schemas to explore its use in generating robotic system control messages. The prior work by the JAUS community can be leveraged significantly to explore such extension and application of C-BML.

The principal focus of SISO is the development of standards addressing the ability of simulation systems to interoperate effectively. However, SISO has not been engaged solely in simulation-to-simulation interoperability, but considers broader perspectives, such as the interaction between a simulation and other kinds of systems, most notably command and control systems and robotics systems. As discussed earlier, the C-BML Phase 1 standard approved in 2014 was an important step in this direction.

As we’ve discussed, the SISO C2SIM PDG is working on enhancements to the C-BML standard through specification of a more formalized logical data model while maintaining and supporting in parallel the current C-BML standard. Application of the current C-BML standard to enhance investigations such as those performed in the SIRI project (i.e., addressing other legs of the interoperability “triangle”), as in demonstrating data interchange across such formulations as JAUS, NIEM, and C-BML, would provide

valuable insights into the applicability and adaptability of the current standard, while providing important inputs to the specification of the logical data model in ongoing standardization work of the C2SIM PDG.

K. SUMMARY

From the background and experience of personnel at NPS, there is opportunity to significantly influence the content of the next generation standard for information interchange across C2 systems, simulation systems, and unmanned systems through collaboration with SISO. We recommend continued involvement with that activity to introduce use cases in the unmanned systems domain that can inform development of that standard. Although we discussed several and highly varied interoperability initiatives relevant to unmanned systems, we could not be exhaustive in our investigation due to the sheer number of such initiatives. Indeed, even at the time of this writing, there is a new call for describing unmanned system interoperability in preparation of a new unmanned system roadmap (expected in the Spring of 2017; we briefly discuss the work in progress in the next chapter, identifying proposed inputs offered by NPS faculty for inclusion in the product). That document will likely lead to new directions in unifying policy for unmanned system interoperability.

III. INPUTS TO THE UNMANNED SYSTEMS INTEROPERABILITY ROADMAP

A. INTRODUCTION

In May 2016, NPS was invited to participate in a working group seeking to develop a new unmanned systems roadmap. NPS faculty and project collaborators responded to a call for inputs. The following subsections identify the information proposed by NPS faculty and other collaborators for roadmap preparation. In August 2016, we were informed that the roadmap preparation was postponed to the Spring 2017, shifting further development of these inputs to FY17, whether on a volunteer basis from submitters or through follow-on tasking to NPS from the JGRE program.

B. UNMANNED SYSTEMS ROADMAP

The working group for a new unmanned systems roadmap (Linkel 2016) states a two-fold vision as:

“Integrate unmanned systems capabilities that provide flexible options for Joint Warfighters while exploiting the inherent advantages of unmanned systems to reduce programmatic, technical, and tactical risk.

DoD envisions unmanned systems seamlessly operating with manned systems with a gradual reduction in the cognitive load for the decision making process.” (p 4)

The primary purpose is to align the unmanned system goals of the services with the strategic vision of the DoD, to include reducing duplicative efforts, enabling collaboration, matching capabilities with needs, identifying common challenges, guiding allocation of research, development, test, and evaluation (RDT&E) funds, providing material solutions for requirements, and reporting on the latest DoD unmanned aerial system capabilities. The proposed draft outline (Linkel 2016) for the new unmanned systems roadmap identifies five major themes (p 10, 12): Human-Machine Interface, Interoperability, Autonomy, Cyber, and Operating Environment. In the area of interoperability, subtopics identified by the group include: common architectures, open architecture (relating to standards and services; logical, electrical, and mechanical interfaces; data models; and information sharing), modularity/parts interchangeability (including systems integration), compliance verification and validation (including test

and evaluation), payload (weapons, cargo, sensors), data rights (relating to technology insertion and rapid innovation), and interoperability with manned operations. We've seen several activities in the previous chapter relating to these topic areas. The challenge facing DoD is to create policy directives that will unify and consolidate the many varied efforts.

As mentioned earlier, NPS faculty members were invited to address selected topics identified by the roadmap working group. The following subsections briefly describe some of the inputs proposed in faculty responses.

1. Trust: Applying Ethical Constraints to Unmanned System Missions⁷

One of the principal gaps/roadblocks identified in the new roadmap work is *trust*, with some reasons stated as “the complexity of AI [artificial intelligence] technology and lack of Industry / Government standards” (Linkel 2016, 7). For several years, members of the NPS faculty have been researching mechanisms for engendering trust through the application of ethical constraints to unmanned system mission specifications, with explicit reliance on fundamental computational theory instead of AI techniques (Brutzman, et al. 2016). A key requirement is the assignment of responsibility on those who control or command unmanned systems (in the same way that human commanders are responsible for the actions of their subordinates), which in turn requires knowledge of the capabilities and limitations of the unmanned system to create confidence (trust) in the ability of the unmanned system to perform the specified mission.

Effective military employment of semi-autonomous systems with potentially lethal capabilities requires ethical constraints on mission tasking that meets moral and legal requirements. Such missions can be logically defined and formally validated in a manner that is understandable across a diverse range of military personnel and robots. This approach keeps human authority at the heart of mission approval for unmanned systems. Some key considerations include:

- Existing joint task orders for unmanned systems are typically robot-specific and idiosyncratic in form. Nevertheless such orders all tend to be quite similar: go to a location, sense other entities and the environment, perform a task, interact and communicate as required, etc.

⁷ Material in this section was provided by Professor Don Brutzman in his response to the call for topic input.

- Robot tasking can be expressed consistently using a formal unambiguous vocabulary that is readable by both humans and computers. Missions can be validated as well-defined and correct.
- Addition of constraint checking to mission steps allows insertion of validatable ethical constraints to permit thorough review and informed decision making by commanders, preserving moral oversight and legal accountability by humans.

Some of the challenges and roadblocks result from concerns that abstract morality-based reasoning is difficult but nevertheless achievable for humans. Situational ethical reasoning is not coherently implementable by artificial intelligence (AI) across the wide range of scenarios encountered by military forces. Human authority, accountability, and ability to command must be preserved as unmanned systems become widely deployed. Significant international efforts focused at the United Nations (UN) are attempting to completely outlaw the deployment of autonomous systems with lethal capabilities - at least for potential combatants that agree to follow international conventions. The basis for such efforts is that unmanned systems cannot ever operate satisfactorily without violating the Law of Armed Conflict (LOAC) and related warfare conventions. Identification of Friend Foe Neutral (IFFN) is the key prerequisite for appropriate response during operations in hostile environments, for human and unmanned systems alike. IFFN is difficult in cluttered land environments, but is feasible for maritime (air/surface/subsurface) and aviation domains.

As a way ahead, we assert that analysis of canonical military missions can precisely identify ethical requirements requiring a human making decisions, for current manned operations and for projected unmanned proxies. Ethical constraints on military missions can be articulated, tested, evaluated, and improved using modeling and simulation techniques. Human control over such autonomous-system missions can then be further tested and verified under field conditions. The existing military framework of operation orders (OPORDs) and cooperative tasking can be augmented to include tasking guidance and validation frameworks for unmanned systems. Coherent expression and evaluation of mission tasking for unmanned systems is an appropriate future role for Open Systems Architecture (OSA) services. Ultimate success for this work can provide accountable commanders with confidence that human-directed tactical tasking of

unmanned systems meets all ethical requirements for Rules of Engagement (ROEs) and LOAC.

In the coming years (perhaps within the next 5 years), it is expected that Unified C2 for unmanned systems that includes ethical constraints on mission tasking will be achieved. This will enable individual ships, aircraft, and submarines to be able to effectively and ethically deploy unmanned systems with lethal potential. Development of similar approaches will become feasible for ground and urban combat. In 10 years, Tactics Techniques and Procedures (TTPs) for IFFN can be consistently reconciled for maritime, littoral, and land domains, and Joint and coalition operations orders can be formally coordinated and deconflicted in accordance with ROE. International ethical considerations can be similarly composed and harmonized in support of commanders' intent, review, and approval. Finally, in later years (perhaps 25), full accountability of policy and practice for human-robot teams becomes possible to evaluate all rules, roles, and execution of augmented military operations.

Some activities that can be performed in the near term include NPS student theses to examine the Mission Essential Task List (METL) for each naval warfare domain (AAW, ASuW, ASW, MIW and IW). Corresponding constraint-based unmanned-system missions can be developed, simulated, visualized, and functionally verified. Deployed unmanned C4ISR assets would be able to safely and securely surveil and interact with mixed forces without threatening noncombatant civilian population or infrastructure. Given IFFN discrimination, unmanned systems can begin to perform specific naval missions (such as barrier alertment/defense, embargo, and mining operations) involving a wide variety of dangerous tasks with acceptable risk for robots, reduced risk for humans, and greatly reduced risk of unintended transgressions against noncombatants.

2. Interoperability: Model-Based Systems and Software Engineering Framework⁸

Much of the current effort in unmanned system design is focused on specific technical issues for implementing the necessary engineering platforms and software. As in any complex engineering domain, these efforts need a support in the form of

⁸ Material in this section was provided by Professor Mikhail Auguston in his response to the call for topic input.

appropriate abstract modeling layers for design, verification, and validation of systems with automated tools. This aspect is represented by the concept of Model-Based Systems and Software Engineering (MBSSE). Engineers should use math, and formal modeling is the mathematical basis for complex system design. It should be simple enough and should address specific needs of the domain to which it is applied. The MBSSE framework addresses several layers of design, including the architecture and design of a particular vehicle, the architecture and behavior of swarms of unmanned vehicles, and the operational processes deploying these swarms. All these models are critical and should be built, analyzed, and verified before the investment in detailed and expensive implementation. This is true for all mission sets and operational processes.

There are many existing tools and methodologies for complex system design and modeling used within DoD systems engineering domain, such as Unified Modeling Language (UML), System Markup Language (SysML), DODAF, Innoslate, CORE, and MATLAB. But, often these approaches don't provide the necessary level of abstraction, lack support for continuity in the design process, and don't have adequate tools for the most challenging phases of system development.

We suggest a simple and expressive framework and tools for system and software architecture and workflow (operational and business process) modeling – Monterey Phoenix (MP).⁹ The main novelty in MP is simple and powerful behavior modeling abstraction and the separation of component behavior models from the interaction models, which appears to be one of the most challenging aspects in systems modeling. MP is capable of modeling system's architecture behavior for all actors and technologies in a problem space, including those in the environment, and all of the possible interactions among those actors and entities exhaustively, finding all possible outcomes within the specified scope. The innovations behind MP provide architects and decision makers with new capability to help them more effectively, including:

- Understand the system's interactions within an environment (including humans).
- Expose gaps, overlaps and inefficiencies in business and operational processes.
- Reduce or remove the occurrence of unwanted behaviors in a system of interest.

⁹ MP tools are implemented and available on the NPS public server <http://firebird.nps.edu/>. Details and reading materials can be found in the Bibliography section on the MP wiki site at <https://wiki.nps.edu/display/MP/Monterey+Phoenix+Home>.

- Evaluate system designs against cost, schedule and performance criteria.

MP significantly amplifies systematic generation of operational scenarios to test proposed alternatives against, providing earlier and a more complete understanding of requirements before trades and alternative selections are made.

Several relevant case studies have been accomplished using MP, including: UAV swarm behavior, where MP tools have been successfully used to identify emergent behaviors; search-and-rescue mission modeling; and improvised explosive device (IED) search and retrieval process model.

3. Operating Environment: Missions/Domains and Key Technologies¹⁰

The effective utilization of unmanned underwater vehicles (UUVs) for general use requires knowledge spanning many technical disciplines. Some of the larger ongoing efforts needed to advance the field are in the areas of control, propulsion, and communication. However, the unique development of these systems specifically for naval military operations also requires knowledge in maneuvering. The testing and validation of UUV maneuvering capabilities should be as rigorous as the requirements for current fleet assets. This requires the examination of the broad field of maneuvering and all the associated tools. One particularly challenging is near surface operation. A submerged near surface UUV will experience an unsteady loading that tends to pull the vehicle toward the surface. As the size of the seaway relative to the underwater vehicle increases, the unsteady loading becomes more severe. Due to the small size of UUVs compared to fleet assets, even fairly mild seaways can present problems. The important factors driving this phenomenon are poorly understood and therefore the unsteady loading is not well predicted.

For tactical mission operations in littoral waters, such as intelligence, surveillance, and reconnaissance (ISR), and mine clearance, UUVs must operate near the surface of a seaway. Furthermore, near surface operation will always occur during the launch and recovery phase of the mission. If the maneuverability has not been tested and verified, completing the mission in the face of these near surface unsteady loads may not

¹⁰ Material in this section was provided by Professor Joseph Klamo in his response to the call for topic input. While it is not clear that the content will be specifically applicable to the new roadmap effort, we retain it here in case it raises certain technical and operational concerns or considerations that may need to be included in the roadmap.

be possible. In a worst case situation, the vehicle can actually broach the surface, exposing its position to the enemy and introducing survivability issues. In such a case the covert mission would be compromised and could potentially result in the loss of the UUV.

The field of UUV utilization for military operations is rapidly developing so there are many technical problems to address. This is not a problem per se, as solutions will most likely emerge from focused research efforts and evolving concepts of operations. However, these issues must start being addressed if using UUVs for many naval missions is a cornerstone of the Navy's future strategy. Regarding maneuvering, the most significant impedance to success is the sustained, multi-year effort that is required to ultimately produce an accurate predictive tool. Previous interest in near surface maneuvering has been by submarine program offices during the early stages of acquisition, but their research and development efforts are too short and not continuous across different programs. They are also hesitant to support an effort that entails a potential long term effort since the knowledge gained might occur too late to support their particular programs.

The 5-year significant development milestone would be the understanding of how the characteristics of the seaway and the operating speed, depth, and geometry of the vehicle drive the severity of the near surface unsteady loading through a series of experiments. A 10-year milestone could encompass the integration of this knowledge into numeric maneuvering simulations in order to more accurately predict these loads for typically encountered seaways. The 25-year milestone would be a single complete end-to-end numeric predictive tool that seamlessly integrates both maneuvering, control, and propulsion aspects of UUV operations for the prediction of mission effectiveness. The ultimate success would entail a complete understanding of the underlying physics governing near surface operation unsteady loading so that UUVs could be designed to mitigate the effect, mission profiles could be selected that minimize the severity of loading, and finally numeric simulations could accurately predict the experienced loads.

The Ohio replacement program is currently assessing the fidelity of the numeric simulations used to make predictions of the unsteady loading on fleet submarines when operating near the surface of a seaway. Some initial progress involved examining

previous submarine class test data to begin identifying key parameters. This typifies the challenges of this topic and highlights the fact that there is very little existing knowledge and thus the fundamentals of the problem must be understood before accurate predictive codes can be created.

4. Human-Machine Interface: Manned/Unmanned Teaming¹¹

The U.S. Army strategy for improving future warfighter capabilities is predicated on “an integrated network and enhanced mobility and lethality” with “expanded use of manned unmanned teaming (MUM-T)” (Baxter and von Eschenbach 2014). These authors describe the technology and its objectives as follows:

“MUM-T is a doctrinally-supported merger of manned air and ground capabilities with current and emerging unmanned system capabilities that provides synchronized employment of soldiers, manned and unmanned air and ground vehicles, robotics, and sensors. The current objective of MUM-T is to augment the respective capabilities of manned and unmanned aviation systems through deliberate teaming and leverage their complementary capabilities and inherent strengths. The MUM-T capability gives the Apache helicopter pilot another set of ‘eyes,’ leveraging UAS to identify specific targets from much greater ranges, to determine the safest way in and out of the weapons engagement zone, and to assist in engaging the target. The Apache can do this by receiving video and target data directly from Army UAS assets such as Gray Eagle or Shadow. The pilot can also use advanced interoperability features to control both the UAS payload and to a limited degree the actual flight path of the UAS.”

Interoperability across manned and unmanned assets is identified as one of the difficult challenges, along with development, testing, and certification. The challenges can be addressed through radio, terminal, and software procurements, together with effective integration and testing.

Near term considerations involve changes in four focus areas that can be implemented today to improve MUM-T capability. These are:

- (1) Improve home-station and multi-echelon training.
- (2) Update doctrine and policy.
- (3) Coordinate plans for airspace deconfliction and airspace management.

¹¹ Material in this section was provided by Mr. William Sobotka, a collaborator on the NPS JGRE project, in his response to the call for topic input.

- (4) Define the Combat Aviation Brigade capability required to distribute sensor data both internal and external.

Mid-term considerations include a list of potential foundational, threat-based, and terrain-based attributes and potential material solutions in Program Objective Memorandum (POM) 19-23 that would benefit the Army when operating in future operational environments. Ultimate success is envisioned as employing manned-unmanned arrangements in such a manner as to operate seamlessly and transparently in the conduct of any mission profile.

Previous Army studies and the ongoing doctrinal maturation are highlighting the organizations and personnel mix required to successfully integrate MUM-T. In (Baxter and von Eschenbach 2014), the authors describe deployment of the 101st Combat Aviation Brigade's (CAB's) Attack Reconnaissance Squadron to Afghanistan augmented with a Shadow troop consisting of two RQ-7 Shadow platoons, each with four air vehicles and two ground control stations. Furthermore, the "United States Army Aviation Center of Excellence (USAACE) conducted an assessment of the effectiveness of the 101st CAB task organization in December 2012 in OEF [Operation Enduring Freedom] and found that the mix of manned and unmanned systems provided greater standoff for manned systems, increased overall area coverage in time and space, and increased situational awareness." The Army Training and Doctrine Command (TRADOC) Analysis Center (TRAC) is conducting a study of the demand signal for this capability in the 2030 timeframe (Training and Doctrine Command Analysis Center n.d.). Such studies are critical to development of new tactics, techniques, and procedures (TTPs) and further evaluation of potential improvements to warfighting effectiveness in the future manned-unmanned battlespace.

THIS PAGE INTENTIONALLY LEFT BLANK

IV. SUMMARY AND RECOMMENDATIONS

A. SUMMARY

Numerous and varied unmanned system interoperability activities have been presented in this report. There is a clear opportunity for greater collaboration across the M&S and unmanned system communities to explore possible benefits of standardization efforts. This fits well with objectives of organizations like the OSD Joint Ground Robotics Enterprise to unify the various efforts underway to define and develop interoperability standards for robotics systems.

B. RECOMMENDATIONS

To stimulate greater interaction between the robotics community and the modeling and simulation community, an immediate action would be formation of a group (possibly a tiger team within the existing C2SIM PDG) to investigate application of the current C-BML standard in a specific use case involving the interchange of data across C2 systems, simulation systems, and robotic systems, possibly building on the work of the SIRI project. As discussed above, this can have immediate benefit in demonstrating capabilities and limitations of the current C-BML standard, while informing ongoing work by the C2SIM PDG in specifying the logical data model for the next-generation standard. Furthermore, this is a critically important standardization effort since it involves inter-communication across C2 systems, simulation systems, and unmanned systems. During the Simulation Innovation Workshop in September 2016, we engaged the SISO community in discussion of this need. Several attendees expressed interest in participating in this work, forming an initial core for follow-on efforts. We will continue this work into FY17 within the C2SIM PDG.

With the importance of modeling and simulation in the engineering and testing of robotics systems, and with the recognition (in the military) that representation of robotics systems in combat simulations is becoming critical to studies of future warfare, it would be beneficial to try to find greater common ground between the modeling and simulation community and the robotics community. Once venues are established for greater collaboration across the communities, additional activities of mutual benefit are certain to emerge. The collaboration can increase validity of work by the C2SIM PDG for

description of use cases and logical data model content for operations involving robotic systems. The FY16 project opened up avenues of opportunity with the DoD robotics community and the international robotics community that can be leveraged as efforts go forward. There is immediate opportunity for the JGRE to serve as a key advocate, proponent, and stakeholder for the standardization efforts underway in SISO.

While this project work focused on information interoperability in unmanned systems, it is recommended that any future unmanned system interoperability standardization for DoD address both physical and information (logical) interconnections for complete openness, as exhibited in the AEODRS engineering efforts.

In light of the FY16 work performed and the relationships established, the following way forward is proposed:

- (1) Form and initiate an unmanned system interoperability standards focus group in the SISO C2SIM PDG effort. Timetable: Before the end of calendar year 2016.
- (2) Develop unmanned system interoperability use cases to identify inputs to the C2SIM logical data model. Timetable: Before the end of the first quarter, calendar year 2017.
- (3) Implement demonstration cases based on the existing (C-BML) and emerging (C2SIM) standard for intercommunication across C2 systems, simulation systems, and unmanned systems. Timetable: By the end of calendar year 2017.

This provides a clear and feasible roadmap toward standardized intercommunication across C2 systems, simulation systems, and unmanned systems. In parallel, we recommend continuation of involvement in other unmanned system interoperability efforts to look for opportunities for cross-group synergies and opportunities for unification of efforts and products.

APPENDIX A. GLOSSARY OF TERMS AND ACRONYMS

AAW	Anti-Air Warfare
AEODRS	Advanced Explosive Ordnance Disposal Robotics System
AI	Artificial Intelligence
AS-4	Aerospace Standards Unmanned Systems Steering Committee
ASUW	Anti-Surface Warfare
ASW	Anti-Submarine Warfare
AT&L	Acquisition, Technology, and Logistics
AV	All View
BML	Battle Management Language
C2	Command and Control
C2SIM	Command and Control Systems - Simulation Systems Interoperation
C4I	Command, Control, Communications, Computers, and Intelligence
C4ISR	Command, Control, Communications, Computers, Intelligence, Surveillance, and Reconnaissance
CAB	Combat Aviation Brigade
C-BML	Coalition Battle Management Language
CCI	Command and Control Interface
CDM	Conceptual Data Model
CDR	Critical Design Review
CIO	Chief Information Office
CJCSI	Chairman of the Joint Chiefs of Staff Instruction
CONOPS	Concept of Operations
COTS	Commercial Off-the-Shelf
DISR	DoD Information Technology Standards and Profile Registry
DLI	Data Link Interface
DoD	Department of Defense
DODAF	Department of Defense Architecture Framework
EOD	Explosive Ordnance Disposal
FACE	Future Airborne Capability Environment
FoS	Family of Systems
FY	Fiscal Year
GEOINT	Geospatial Intelligence
GFMSA	Geospatial Intelligence Functional Manager Seal of Approval
GJXDM	Global Justice XML Data Model
HIWG	Horizontal Integration Working Group
ICD	Interface Control Document
ICWG	Interface Control Working Group
IED	Improvised Explosive Device
IFFN	Identification Friend Foe Neutral
I-IPT	Interoperability Integrated Product Team
IOP	Interoperability Profile

ISR	Intelligence, Surveillance, and Reconnaissance
IT	Information Technology
IW	Information Warfare
JAFIP	Joint Architecture Federation and Integration Project
JAUGS	Joint Architecture for Unmanned Ground Systems
JAUS	Joint Architecture for Unmanned Systems
JC3IEDM	Joint Consultation, Command and Control Information Exchange Data Model
JCIDS	Joint Capabilities Integration and Development System
JCUA	Joint Common Unmanned System Architecture
JGRE	Joint Ground Robotics Enterprise
JITC	Joint Interoperability Test Command
JMTAT	Joint Mission Thread Architecture and Testing
JSIL	Joint Technology Center/Systems Integration Laboratory
LDM	Logical Data Model
LOAC	Law of Armed Combat
LOI	Level of Interoperability
LVC	Live, Virtual, Constructive
M&S	Modeling and Simulation
MBSSE	Model Based Systems and Software Engineering
MESAS	Modeling and Simulation for Autonomous Systems
METL	Mission Essential Task List
MIM	MIP Information Model
MIP	Multilateral Interoperability Programme
MIW	Mine Warfare
MP	Monterey Phoenix
MUM-T	Manned-Unmanned Teaming
NATO	North Atlantic Treaty Organization
NAVSEA	Naval Sea Systems Command
NIEM	National Information Exchange Model
NIST	National Institute of Standards and Technology
NPS	Naval Postgraduate School
NR KPP	Net Ready Key Performance Parameter
OPORD	Operation Order
OSA	Open System Architecture
OSD	Office of the Secretary of Defense
OUSD	Office of the Under Secretary of Defense
PDG	Product Development Group
POM	Program Objective Memorandum
PoR	Program of Record
RAS	Robotic and Autonomous System
RDT&E	Research, Development, Test & Evaluation
ROE	Rules of Engagement
SAE	Society of Automotive Engineers
SIRI	Simulated Interactive Robotics Initiative

SISO	Simulation Interoperability Standards Organization
SIW	Simulation Innovation Workshop
SOA	Service Oriented Architecture
SoS	System of Systems
SPIES	Sensor/Platform Interface and Engineering Standardization
STANAG	Standardization Agreement
SysML	System Markup Language
TRAC	TRADOC Analysis Center
TRADOC	Training and Doctrine Command
TTP	Tactics, Techniques, Procedures
UAS	Unmanned Aircraft System
UAV	Unmanned Aerial Vehicle
UCS	UAS Control Segment
UGV	Unmanned Ground Vehicle
UI2	Unmanned Interoperability Initiative
UML	Unified Modeling Language
UN	United Nations
U.S.	United States
USAACE	United States Army Aviation Center of Excellence
USIP	Unmanned System Interoperability Profile
UUV	Unmanned Underwater Vehicle
WG	Working Group
XML	Extensible Markup Language

THIS PAGE INTENTIONALLY LEFT BLANK

LIST OF REFERENCES

- Alejo, C., I. Alejo, Y. Rodriguez, and A. Viguria. "Simulation engineering tools for algorithm development and validation applied to unmanned systems." Edited by Jan Hodicky. *Modelling and Simulation for Autonomous Systems: First International Workshop, MESAS 2014*. Heidelberg: Springer, 2014. 281-291.
- Aviation and Missile Research, Development, and Engineering Center. n.d.
<https://www.amrdec.army.mil/amrdec>.
- Baxter, Tim, and Tom von Eschenbach. "Manned-unmanned teaming." *Ground Combat Technology*, April 24, 2014.
- Blais, C. "Challenges in representing human-robot teams in combat simulation." Edited by Jan Hodicky. *Modelling and Simulation for Autonomous Systems: Third International Workshop, MESAS 2016*. Heidelberg: Springer, 2016. 1-14.
- Blais, C. L. "Standards for unmanned system interoperability." *Simulation Innovation Workshop*. Simulation Interoperability Standards Organization, 2016.
- Brutzman, Don, Duane Davis, Curtis Blais, and Robert McGhee. "Ethical mission definition and execution for maritime and naval robotic vehicles: A practical approach." *OCEANS '16*. Monterey: Institute of Electronic and Electrical Engineers, 2016.
- Chairman of the Joint Chiefs of Staff. "Joint Capabilities Integration and Development System (JCIDS)." CJCS Instruction 3170.01I, 2015.
- Chairman of the Joint Chiefs of Staff. "Net Ready Key Performance Parameter (NR KPP)." CJCS Instruction 6212.01F, 2012.
- Davis, D., C. Blais, and D. Brutzman. "Autonomous vehicle command language for simulated and real robotic forces." *Fall Simulation Interoperability Workshop*. Simulation Interoperability Standards Organization, 2006.
- Del Signore, M. J. "An open systems architecture approach for EOD unmanned vehicles." *Interoperability Open Architecture 2015*. London, 2015.
- Department of Defense. "DoD Modeling and Simulation Glossary." 2010.
http://www.msco.mil/documents/_4_Final_Glossary.pdf.
- Department of Defense. "Implementation Convention (IC) 1 for Unmanned System Interoperability Profile (USIP) 1." 2008.
- Department of Defense. "Information Technology Standards in the DoD." DoD Instruction 8310.01, 2015.
- Department of Defense. "Interoperability Steering Group Charter." 2012.
- Department of Defense. "Unmanned Systems Integrated Roadmap FY2013-2038." Reference Number: 14-S-0553, 2013.
- Fedi, F., and F. Nasca. "Interoperability issues reduction in command and control for multi-robot systems." Edited by Jan Hodicky. *Modelling and Simulation for Autonomous Systems: Second International Workshop, MESAS 2015*. Heidelberg: Springer, 2015. 77-89.
- Ferrati, M., A. Settini, and L. Pallottino. "ASCARI: A component based simulator for distributed mobile robot systems." Edited by Jan Hodicky. *Modelling and Simulation for Autonomous Systems: First International Workshop, MESAS 2014*. Heidelberg: Springer, 2014. 152-163.

Fisherkeller, K. "Emerging Interoperability Standards for Unmanned Aerial Systems." *19th Annual INCOSE Region II Fall Mini-Conference*. San Diego, 2014.

Gregory, D. *UCS Architecture*. SAE International, 2016.

Headquarters of the Department of the Army. "Operational Terms and Graphics." FM 1-02 (FM 101-5-1) MCRP 5-12A, 2004.

Heffner, K., and Fawzi Hassaine. "Using BML for command & control of autonomous unmanned air systems." *Fall Simulation Interoperability Workshop*. Simulation Interoperability Standards Organization, 2010.

Hodicky, J. "HLA as an experimental backbone for autonomous system integration into operational field." Edited by Jan Hodicky. *Modelling and Simulation for Autonomous Systems: First International Workshop, MESAS 2014*. Heidelberg: Springer, 2014. 121-126.

Hoffman, E. M., et al. "Yarp based plugins for Gazebo simulator." Edited by Jan Hodicky. *Modelling and Simulation for Autonomous Systems: First International Workshop, MESAS 2014*. Heidelberg: Springer, 2014. 333-346.

Institute of Electronic and Electrical Engineers. "The Authoritative Dictionary of IEEE Standards Terms (Seventh Edition)." IEEE 200-2000, 2000.

JAUS. "The Joint Architecture for Unmanned Systems: Reference Architecture Specification." Volume II, Part 1, Architecture Framework, Version 3.3, 2007.

Joint Interoperability Test Command. n.d. <http://jitic.fhu.disa.mil/index.aspx>.

Kreisher, O. "Smallest of Navy's 3 advanced EOD robots passed critical design review." *United States Naval Institute News*, June 17, 2016.

Linkel, Jak. "2016 Unmanned Systems Roadmap: Status Meeting." Department of Defense AT&L, June 3, 2016.

Litwiller, S., M. Weber, and F. Klucznik. "Improving robotic and autonomous systems information interoperability: Standardizing data exchanges with XML." Edited by Jan Hodicky. *Modelling and Simulation for Autonomous Systems: Second International Workshop, MESAS 2015*. Heidelberg: Springer, 2015. 24-39.

Matthews, R., and R. Sweeney. *PMA209 Industry Day Future Airborne Capability Environment (FACE)*. Naval Air Systems Command, 2013.

Multilateral Interoperability Programme. *Public Website*. n.d. <https://mipsite.lsec.dnd.ca/Pages/Default.aspx>.

Multilateral Interoperability Programme. "The Joint C3 Information Exchange Data Model (JC3IEDM Main)." JC3IEDM-MAIN-IPT3, V3.1.4, Greding, 2012.

National Institute of Standards and Technology. "Autonomy Levels for Unmanned Systems (ALFUS) Framework. Volume 1: Terminology. Version 2.0." Special Publication 1011-I-2.0, 2008.

National System for Geospatial Intelligence. "NSG Strategy 2013-2018." 2013.

North Atlantic Treaty Organization. *STANAG 4586 (Edition 3) - Standard Interfaces of UAV Control System (UCS) for NATO UAV Interoperability*. NSA/1235(2012)4586, NATO/OTAN, 2012.

Office of Homeland Security. "National Strategy for Homeland Security." 2002.

Office of the Under Secretary of Defense for Acquisition, Technology and Logistics. "Department of Defense Report to Congress on Addressing Challenges for Unmanned Aircraft Systems." 2013.

- Robotic Systems Joint Project Office. "Unmanned Ground Vehicle (UGV) Interoperability Profile (IOP) Overarching Profile Version 0." 2011.
- SAE International. "AS-1 aircraft systems & systems integration." *Avionics Systems Group Newsletter*, Fall 2013: 2-6.
- SAE International. "Unmanned Systems (UxS) Control Segment (UCS) Architecture: Model." Standard AS6518, n.d.
- Simulation Interoperability Standards Organization. "Standard for Coalition Battle Management Language Phase 1." SISO-STD-011-2014, 2014.
- The Open Group. *Future Airborne Capability Environment Technical Standard Edition 2.1*. n.d. <http://www.opengroup.org/face/tech-standard-2.1>.
- Tolk, A. "Modeling and simulation interoperability concepts for multidisciplinary, interdisciplinary, and transdisciplinarity -- Implications for computational intelligence enabling autonomous systems." Edited by Jan Hodicky. *Modelling and Simulation for Autonomous Systems: Second International Workshop, MESAS 2015*. Heidelberg: Springer, 2015. 60-74.
- Training and Doctrine Command Analysis Center. "Manned-Unmanned Teaming." n.d. <http://www.trac.army.mil/documents/2030%20Manned%20Unmanned%20Teaming%20Study.pdf> (accessed September 30, 2016).
- United States House of Representatives. "Department of Defense Appropriations Bill for 2017, Report of the Committee on Appropriations." House Report 114-577, 2016.
- Unmanned Aircraft System (UAS) Control Segment (UCS) Working Group. *UCS Architecture*. n.d. <https://ucsarchitecture.org>.
- Unmanned Interoperability Initiative. "Unmanned Interoperability Initiative (UI2) Capability Based Assessment." 2012.
- Vonasek, V., D. Fiser, K. Kosnar, and L. Preucil. "A light-weight robot simulator for modular robotics." Edited by Jan Hodicky. *Modelling and Simulation for Autonomous Systems: First International Workshop, MESAS 2014*. Heidelberg: Springer, 2014. 206-216.
- Welby, Stephen P. "A guest editorial: Standards." *Modeling and Simulation Journal* (DoD Modeling & Simulation Coordination Office) Spring (2013).

THIS PAGE INTENTIONALLY LEFT BLANK

INITIAL DISTRIBUTION LIST

1. Defense Technical Information Center
Ft. Belvoir, Virginia
2. Dudley Knox Library
Naval Postgraduate School
Monterey, California
3. Research Sponsored Programs Office, Code 41
Naval Postgraduate School
Monterey, CA 93943
4. Shad Reese
Office of the Secretary of Defense Joint Ground Robotics Enterprise
Washington, DC
5. Jaret Riddick
Office of the Secretary of Defense Joint Ground Robotics Enterprise
Washington, DC