



Calhoun: The NPS Institutional Archive
DSpace Repository

Theses and Dissertations

1. Thesis and Dissertation Collection, all items

2010-06

An integrated command and control architecture concept for unmanned systems in the year 2030

Johnson, Jamarr J.; Buckley, Omari D.; Cunningham,
Dustin; Matthews, Adam; Quincy, Keith E.; Fontenot, Dion
G.; Moran, Michael G.; Tham, Gabriel; Wong, Jason; Quah, Raymond...
Monterey, California. Naval Postgraduate School

<https://hdl.handle.net/10945/5244>

This publication is a work of the U.S. Government as defined in Title 17, United States Code, Section 101. Copyright protection is not available for this work in the United States.

Downloaded from NPS Archive: Calhoun



Calhoun is the Naval Postgraduate School's public access digital repository for research materials and institutional publications created by the NPS community. Calhoun is named for Professor of Mathematics Guy K. Calhoun, NPS's first appointed -- and published -- scholarly author.

Dudley Knox Library / Naval Postgraduate School
411 Dyer Road / 1 University Circle
Monterey, California USA 93943

<http://www.nps.edu/library>



NAVAL POSTGRADUATE SCHOOL

MONTEREY, CALIFORNIA

INTEGRATED PROJECT

**An Integrated Command and Control Architecture Concept for
Unmanned Systems in the Year of 2030**

By

Omari D Buckley
Jamarr J. Johnson
Drew J. Nilsson

Dustin Cunningham
Adam Matthews
Keith E. Quincy

Dion G. Fontenot
Michael G. Moran
Bradley G. Thompson

Ang Teo Hong
Tan Wei Chieh
Lim Wei Han Eugene
Lo Chee Hun
Lu Chin Leong
Toh Boo Pin
Gabriel Tham
Jason Wong
Ho Liang Yoong

Ng Yeow Cheng
Chia Boon Chye
Ng Wei Gee
Tan Chin Wah John
Tong Kee Leong
Raymond Quah
Tan Yean Wee
Ting Chi Yon

Tommy Chia
Yionon Costica
Delvin Gho
Ang Kha Luna
Quek Chee Luna
Henry Seet
Lim Han Wei
Wong Ka-Yoon

June 2010

Approved for public release; distribution is unlimited

THIS PAGE INTENTIONALLY LEFT BLANK

REPORT DOCUMENTATION PAGE			Form Approved OMB No. 0704-0188	
Public reporting burden for this collection of information is estimated to average 1 hour per response, including the time for reviewing instruction, searching existing data sources, gathering and maintaining the data needed, and completing and reviewing the collection of information. Send comments regarding this burden estimate or any other aspect of this collection of information, including suggestions for reducing this burden, to Washington headquarters Services, Directorate for Information Operations and Reports, 1215 Jefferson Davis Highway, Suite 1204, Arlington, VA 22202-4302, and to the Office of Management and Budget, Paperwork Reduction Project (0704-0188) Washington DC 20503.				
1. AGENCY USE ONLY (Leave blank)		2. REPORT DATE June 2010	3. REPORT TYPE AND DATES COVERED Technical Report	
4. TITLE AND SUBTITLE An Integrated Command and Control Architecture Concept for Unmanned Systems in the Year 2030			5. FUNDING NUMBERS N/A	
6. AUTHOR(S) Keith E. Quincy, Jamarr J. Johnson, Michael G. Moran, Drew J. Nilsson, and Bradley G. Thompson				
7. PERFORMING ORGANIZATION NAME(S) AND ADDRESS(ES) Naval Postgraduate School Monterey, CA 93943-5000			8. PERFORMING ORGANIZATION REPORT NUMBER NPS-SE-10-003	
9. SPONSORING /MONITORING AGENCY NAME(S) AND ADDRESS(ES) N/Naval Expeditionary Combat Command (NECC)			10. SPONSORING/MONITORING AGENCY REPORT NUMBER	
11. SUPPLEMENTARY NOTES: The views expressed in this thesis are those of the author and do not reflect the official policy or position of the Department of Defense or the U.S. Government.				
12a. DISTRIBUTION / AVAILABILITY STATEMENT Approved for public release; distribution is unlimited			12b. DISTRIBUTION CODE A	
13. ABSTRACT (maximum 200 words) U.S. Forces require an integrated Command and Control Architecture that enables operations of a dynamic mix of manned and unmanned systems. The level of autonomous behavior correlates to: 1) the amount of trust with the reporting vehicles, and 2) the multi-spectral perspective of the observations. The intent to illuminate the architectural issues for force protection in 2030 was based on a multi-phased analytical model of High Value Unit (HVU) defense. The results showed that autonomous unmanned aerial vehicles are required to defeat high-speed incoming missiles. To evaluate the level of autonomous behavior required for an integrated combat architecture, geometric distributions were modeled to determine force positioning, based on a scenario driven Detect-to-Engage timeline. Discrete event simulation was used to schedule operations, and a datalink budget assessment of communications to determine the critical failure paths in the the integrated combat architecture. The command and control principles used in the integrated combat architecture were based on Boyd's OODA (Observe, Orient, Decide, and Act) Loop. A conservative fleet size estimate, given the uncertainties of the coverage overlap and radar detection range, a fleet size of 35 should be anticipated given an UAV detection range of 20km and radar coverage overlap of 4 seconds.				
14. SUBJECT TERMS Integrated Command and Control (c2) Architectures, UAV, USV, UGV, UUV, UMS, UMS Management, Joint Systems Vehicles Concepts.			15. NUMBER OF PAGES 407	
			16. PRICE CODE	
17. SECURITY CLASSIFICATION OF REPORT Unclassified	18. SECURITY CLASSIFICATION OF THIS PAGE Unclassified	19. SECURITY CLASSIFICATION OF ABSTRACT Unclassified	20. LIMITATION OF ABSTRACT UU	

THIS PAGE INTENTIONALLY LEFT BLANK

Approved for public release; distribution is unlimited

**An Integrated Command and Control Architecture Concept
for Unmanned Systems in the Year 2030**

Keith E. Quincy
CDR, USN

BS Marine Science, Jacksonville University, 1991

Bradley G. Thompson
LT, USN

BS Electrical Engineering Technology, Old Dominion University, 2003

Michael G. Moran
LT, USN

BS Political Science, U.S. Naval Academy, 2004

Drew J. Nilsson
LT, USN

BS Business Administration, Boston University, 2003

Jamarr J. Johnson
LT, USN

BS Economy, Auburn University, 2004

Submitted in partial fulfillment of the requirements for the degree of

MASTER OF SCIENCE IN SYSTEMS ENGINEERING ANALYSIS

from the

NAVAL POSTGRADUATE SCHOOL

June 2010

**NAVAL POSTGRADUATE SCHOOL
Monterey, California 93943-5000**

Daniel T. Oliver
President

Leonard A. Ferrari
Executive Vice President and Provost

This report was prepared by the students of the Systems Engineering Analysis (SEA) program Cohort 16 as an integral part of their educational process and is a degree requirement for them. The SEA team was augmented by students under the auspices of the (Singapore) Temasek Defense Systems Institute (TDSI) as well as students from other curricula to permit the team to address the broad, interdisciplinary nature of the project.

Reproduction of all or part of this report is authorized.

This report was prepared by:

SEA Students:

CDR Keith E. Quincy, USN

LT Bradley G. Thompson, USN

LT Michael G. Moran, USN

LT Drew J. Nilsson, USN

LT Jamarr J. Johnson, USN

Extended USN Members:

LT Omari D. Buckley, USN

LT Dustin Cunningham, USN

LT Adam Matthews, USN

LT Dion G. Fontenot, USN

TDSI Students:

MAJ Ang Teo Hong

NY Yeow Cheng

Tommy Chia

CPT Tan Wei Chieh

Chia Boon Chye

Yinon Costica

CPT Lim Wei Han Eugene

ME5 Ng Wei Gee

Delvin Gho

ME5 Lo Chee Hun

ME4 Tan Chin Wah John

Ang Kah Kin

Lu Chin Leong

Me5 Tong Kee Leong

Quek Chee Luan

Toh Boon Pin

Raymond Quah

Henry Seet

ME5 Gabriel Tham

Tan Yean Wee

MAJ Lim Han Wei

Maj Ting Chi Yon

Ho Liang Yoong

Jason Wong

Wong Ka-Yoon

Reviewed by:

Gary Langford
Project Advisor

Charles N. Calvano
OPNAV SEA Chair

Accepted by:

Cliff Whitcomb
Systems Engineering Dept.

Robert Dell
Operations Research Dept.

Released by:

Karl A. van Bibber, Ph.D.
Vice President and Dean of Research

THIS PAGE INTENTIONALLY LEFT BLANK

ABSTRACT

U.S. Forces require an integrated Command and Control Architecture that enables operations of a dynamic mix of manned and unmanned systems. The level of autonomous behavior correlates to: 1) the amount of trust with the reporting vehicles, and 2) the multi-spectral perspective of the observations.

The intent to illuminate the architectural issues for force protection in 2030 was based on a multi-phased analytical model of High Value Unit (HVU) defense. The results showed that autonomous unmanned aerial vehicles are required to defeat high-speed incoming missiles.

To evaluate the level of autonomous behavior required for an integrated combat architecture, geometric distributions were modeled to determine force positioning, based on a scenario driven Detect-to-Engage timeline. Discrete event simulation was used to schedule operations, and a datalink budget assessment of communications to determine the critical failure paths in the the integrated combat architecture.

The command and control principles used in the integrated combat architecture were based on Boyd's OODA (Observe, Orient, Decide, and Act) Loop. A conservative fleet size estimate, given the uncertainties of the coverage overlap and radar detection range, a fleet size of 35 should be anticipated given an UAV detection range of 20km and radar coverage overlap of 4 seconds.

THIS PAGE INTENTIONALLY LEFT BLANK

TABLE OF CONTENTS

1.0.	INTRODUCTION	1
1.1	PROJECT BACKGROUND.....	1
1.2.	FUTURE STAKEHOLDERS	2
1.3.	PROJECT TASKING	2
1.3.1.	Systems Engineering and Analysis (SEA) Tasking Statement	2
1.4.	SCOPING	4
1.4.1.	Tasking Interpretation	4
1.4.1.1.	<i>Tasking Statement Decomposition</i>	<i>4</i>
1.4.1.2.	<i>Project Team Interpretation.....</i>	<i>6</i>
1.4.2.	Project Limitations	9
1.5.	SYSTEMS ENGINEERING PROCESS.....	10
1.5.1.	Development of Systems Engineering Process Model	10
1.5.2.	Systems Engineering “Vee” Process.....	10
1.5.3.	SEA-16 Project Tailored Process	12
1.5.3.1.	<i>Project Definition Phase</i>	<i>13</i>
1.5.3.2.	<i>Systems Analysis Phase.....</i>	<i>14</i>
1.5.3.3.	<i>Preliminary Design Phase.....</i>	<i>14</i>
1.5.3.4.	<i>Systems Design for Utility Phase</i>	<i>15</i>
1.6.	TEAM ORGANIZATION, ROLES, RESPONSIBILITY	15
1.6.1.	Team Composition	15
1.6.2.	Integrated Project Teams.....	16
1.6.2.1.	<i>Integrated Project Team 1.....</i>	<i>16</i>
1.6.2.2.	<i>Integrated Project Team 2.....</i>	<i>17</i>
1.6.2.3.	<i>Integrated Project Team 3.....</i>	<i>17</i>
1.6.2.4.	<i>Integrated Project Team 4.....</i>	<i>17</i>
1.6.3.	Track Teams.....	18
1.6.3.1.	<i>Systems Engineering Track Team.....</i>	<i>18</i>
1.6.3.2.	<i>Simulation Track Team.....</i>	<i>18</i>
1.6.3.3.	<i>Communications, Networks, and Sensors Track Team.....</i>	<i>19</i>
1.6.3.4.	<i>Information Assurance Track Team</i>	<i>20</i>
1.6.3.5.	<i>Weapons Track Team.....</i>	<i>20</i>
2.0.	CONCEPT OF OPERATIONS (CONOPS)	23
2.1.	PROJECT DESCRIPTION	23
2.2.	BACKGROUND	23
2.3.	TRENDS AND ASSUMPTIONS.....	24
2.3.1.	Technology Trends.....	24
2.3.2.	Assumptions	27
2.4.	OVERVIEW OF THE ENVISIONED SYSTEM	29
2.4.1.	Overview	29
2.4.2.	System Scope	30

2.5.	GLOSSARY.....	30
2.6.	DOCUMENT REFERENCES.....	30
2.7.	GOALS, OBJECTIVES AND RATIONALE FOR THE NEW SYSTEM	31
	2.7.1. Goals and Objectives of the New Capability	31
	2.7.2. Rationale for the New Capability	32
2.8.	HIGH-LEVEL FUNCTIONAL REQUIREMENTS.....	32
	2.8.1. High Level Features.....	32
	2.8.2. Additional Features	34
2.9.	IMPACT CONSIDERATIONS.....	34
	2.9.1. Operational and Organizational Impacts.....	34
	2.9.2. Consequence Analysis.....	34
	2.9.2.1. <i>Failure to Act</i>	35
	2.9.2.2. <i>Impact of Implementation</i>	35
2.10.	STAKEHOLDER ANALYSIS	36
	2.10.1. Interested Organizations	36
	2.10.2. Affected Organizations.....	36
	2.10.3. Stakeholder Functions.....	37
	2.10.4. Stakeholder Capabilities	38
	2.10.5. Analysis of Stakeholder Needs.....	39
	2.11.1. Overall Architecture Characteristics.....	40
	2.11.2. Command and Control Factors.....	43
	2.11.3. Network Factors.....	44
	2.11.4. Operational Factors.....	46
3.0.	SYSTEMS ANALYSIS	47
3.1.	COMMAND AND CONTROL CONCEPT.....	47
	3.1.1. Boyd's OODA Loop.....	47
3.2.	OVERVIEW OF UNMANNED SYSTEMS (UMS)	49
	3.2.1. Range of UMS	49
	3.2.2. Classes of UMS Classes of UMS	51
	3.2.2.1. <i>Unmanned Aerial Vehicles (UAV)</i>	51
	3.2.2.2. <i>Unmanned Ground Vehicles (UGV)</i>	52
	3.2.2.3. <i>Maritime Unmanned Vehicles</i>	53
	3.2.2.4. <i>Unmanned Outer Space Vehicles (UOSV)</i>	55
	3.2.3. Implications of Using UMS	55
	3.2.3.1. <i>Advantages of UMS</i>	55
	3.2.3.2. <i>Disadvantages of UMS</i>	56
3.3.	AUTONOMY LEVELS FOR UNMANNED SYSTEMS (ALFUS).....	57
	3.3.1. Definitions of Autonomy.....	57
	3.3.1.1. <i>Dictionary Definition of Autonomy</i>	57
	3.3.1.2. <i>SEA-16 Definition of Autonomy</i>	57
	3.3.2. ALFUS Framework	57
	3.3.3. ALFUS Characteristics	59
	3.3.4. ALFUS and Bandwidth	60

3.3.5.	Autonomy Levels for Unmanned Systems (ALFUS).....	62
3.4.	MAN IN THE LOOP ANALYSIS.....	66
3.4.1.	Human and Machine Strength Comparison	67
3.4.2.	Sources of Human and Mechanical Error.....	70
3.4.3.	Command and Control Considerations	70
3.4.4.	Functional Performance Role Allocation.....	72
3.4.5.	Current Decision Methodology.....	73
3.4.6.	Human Machine Collaborative Decision Making (HMCDM).....	75
3.5.	INFORMATION ASSURANCE CONSIDERATIONS FOR C2 ARCHITECTURE	77
3.5.1.	Identity and Key Management	77
3.5.2.	High Assurance Internetworking	78
3.5.3.	Tamper-Proof Device.....	79
3.5.4.	Availability and Denial of Service	82
3.6.	ENGINEERING ASSESSMENT OF CAPABILITIES UNMANNED SYSTEMS: ENGINEERING FOR 2030	84
3.6.1.	Introduction.....	84
3.6.2.	Fuel Cycle Efficiency	84
3.6.2.1.	<i>Internal Combustion Engines</i>	84
3.6.2.2.	<i>Diesel Engines</i>	86
3.6.2.3.	<i>Gas Turbines</i>	87
3.6.2.4.	<i>Pulse Detonation Engines (PDEs)</i>	89
3.6.2.5.	<i>Constant-Volume-Combustion (CVC) Hybrid Engines</i>	91
3.6.2.6.	<i>Forecast of Cycle Efficiency Increases</i>	92
3.6.3.	Advanced Fuel Technology	93
3.6.3.1.	<i>Distillate Fuel</i>	94
3.6.3.2.	<i>Bio-Fuel</i>	94
3.6.3.3.	<i>Future of Fuel Technology</i>	97
3.6.4.	Battery Technology	97
3.6.4.1.	<i>Current Battery Technology</i>	97
3.6.4.2.	<i>Lithium-Ion</i>	98
3.6.4.3.	<i>Lithium Iron Phosphate LiFePO₄</i>	99
3.6.4.4.	<i>Future Battery Developments</i>	100
3.6.5.	Fuel Cell Technology	100
3.6.5.1.	<i>Polymer Electrolyte Membrane</i>	101
3.6.6.	Case Study: UAV application	102
3.7.	Legal Consideration.....	105
3.7.1.	International Laws.....	105
3.7.1.1.	<i>Law of Armed Conflict</i>	105
3.7.1.2.	<i>United Nations Convention on the Law of the Sea (UNCLOS)</i>	106
3.7.1.3.	<i>International Civil Aviation Organization (ICAO)</i>	106
3.7.2.	National Sovereignty.....	106
3.7.3.	Issues within the United States	107
4.0.	SYSTEM ANALYSIS	109

4.1.	FUNCTIONAL ARCHITECTURE	109
4.1.1.	Functional architecture Development.....	109
4.1.1.1.	<i>Functional Architecture Description.....</i>	<i>109</i>
4.1.1.2.	<i>Developing the Functional Architecture.....</i>	<i>111</i>
4.1.2.	Functional Architecture Overview and Summary.....	113
4.1.2.1.	<i>Description.....</i>	<i>113</i>
4.1.2.2.	<i>Purpose and Scope</i>	<i>113</i>
4.1.2.3.	<i>Mission.....</i>	<i>114</i>
4.1.3.	Functional Description	114
4.1.3.1.	<i>Manage UV Operations.....</i>	<i>114</i>
4.1.3.2.	<i>Provide C2.....</i>	<i>130</i>
4.1.3.3.	<i>Collaborate.....</i>	<i>150</i>
4.1.3.4.	<i>Conduct UV Operations</i>	<i>159</i>
4.1.3.5.	<i>Functional Measures of Effectiveness</i>	<i>171</i>
4.2.	COMMAND AND CONTROL ARCHITECTURE.....	176
4.2.1.	C2 Architecture Considerations in Unmanned Platform.....	176
4.2.2.	OV-1 High Level Operational Concept Graphic	178
4.2.3.	OV-2 Operational Node Connectivity Description	181
4.2.3.1.	<i>Protective Operation.....</i>	<i>181</i>
4.2.3.2.	<i>Search Operation.....</i>	<i>183</i>
4.2.4.	OV-3 Operational Information Exchange Matrix	184
4.2.4.1.	<i>Information Exchange Model.....</i>	<i>185</i>
4.2.4.2.	<i>Categories of Information Exchange</i>	<i>186</i>
4.2.4.3.	<i>MS/ UV (Master)-to-HQ Information Exchange</i>	<i>187</i>
4.2.4.4.	<i>HQ-to-UV (Master) Information Exchange</i>	<i>189</i>
4.2.4.5.	<i>HQ-to-MS Information Exchange</i>	<i>190</i>
4.2.4.6.	<i>UV (Master)-to-UV (Subordinate) Information Exchange.....</i>	<i>190</i>
4.2.4.7.	<i>UV (Subordinate)-to-UV (Master) Information Exchange.....</i>	<i>191</i>
4.2.4.8.	<i>Concluding Remarks.....</i>	<i>192</i>
4.2.5.	OV-5 Operational Activity Model.....	192
4.2.5.1.	<i>OV-5 Force Protection</i>	<i>193</i>
4.2.5.2.	<i>OV-5 Reconnaissance</i>	<i>194</i>
4.2.5.	SV-1	195
4.2.6.	Communications and Network	196
4.2.6.1.	<i>Communications & Network Topology</i>	<i>197</i>
5.0.	EFFECTIVENESS ANALYSIS / FLEET-SIZING	206
5.1.	OBJECTIVE AND APPROACH	206
5.1.1.	ASCM Threat Scenario	206
5.1.2.	Determine UAV Fleet Size for ASCM Early Warning Screen	207
5.2.	OPERATIONAL SCENARIO: DEFENSE OF CARRIER BATTLE GROUP	207
5.3.	DEPLOYMENT CONCEPT	209

5.4.	MOES & MOPS.....	211
5.5.	RADAR CONSIDERATIONS.....	212
	5.5.1. Today’s Technological Limitations	212
5.6.	KEY ASSUMPTIONS.....	216
5.7.	ANALYSIS METHODOLOGY AND RESULTS	217
	5.7.1. A Two Phase Model	217
	5.7.2. Modeling Phase I: Derive Required Number of Aerial Picket Stations.....	217
	5.7.2.1. <i>Overview</i>	217
	5.7.2.2. <i>Description</i>	217
	5.7.2.3. <i>Results and Sensitivity Analysis</i>	221
	5.7.3. Modeling Phase II: Determine Fleet Size.....	221
	5.7.3.1. <i>Overview</i>	221
	5.7.3.2. <i>Description</i>	221
	5.7.3.3. <i>Formulation</i>	222
	5.7.3.4. <i>Results</i>	226
5.8.	COMMUNICATION AND NETWORK ANALYSIS	230
5.9.	RANGE ASSESSMENT: LINK BUDGET FOR SURFACE-TO-AIR COMMUNICATIONS LINK	234
6.0.	RESULTS	240
	6.1. SUMMARY OF RESEARCH	240
	6.2. RECOMMENDATIONS.....	241
	6.2.1. Actions Needed Prior to 2030.....	241
	6.3. FUTURE AREAS OF STUDY	243
7.0.	GLOSSARY, ACRONYMS, AND ABBREVIATIONS	244
	7.1. GLOSSARY.....	244
	7.2. ACRONYMS.....	248
	7.3. ABBREVIATIONS.....	260
8.0.	LIST OF REFERENCES.....	262
 APPENDIX A NAVAL EXPEDITIONARY COMBAT COMMAND (NECC) RESEARCH.....264		
A.1.	OVERVIEW OF NECC.....	264
	A.1.1. Mission Overview.....	264
	A.1.2. Force Capabilities	265
A.2.	SCOPING FORCE CAPABILITIES FOR ANALYSIS.....	265
A.3.	CONTEMPORARY ANALYSIS OF SELECTED NECC CAPABILITIES.....	266
	A.3.1. Riverine Force Analysis.....	266
	A.3.1.1. <i>Organization</i>	266
	A.3.1.2. <i>Missions</i>	267

A.3.1.3.	<i>Operations</i>	268
A.3.1.4.	<i>Operational Capabilities</i>	269
A.3.1.5.	<i>Operational Limitations</i>	270
A.3.1.6.	<i>Environment</i>	270
A.3.1.7.	<i>Threats</i>	270
A.3.1.8.	<i>Utilization of UMS</i>	271
A.3.2.	Explosive Ordnance Disposal Analysis	271
A.3.2.1.	<i>Organization</i>	271
A.3.2.2.	<i>Mission</i>	273
A.3.2.3.	<i>Concept of Operations</i>	274
A.3.2.4.	<i>Operational Limitations</i>	275
A.3.2.5.	<i>Environment</i>	276
A.3.2.6.	<i>Threats</i>	276
A.3.2.7.	<i>Utilization of UMS</i>	276
A.3.3.	Maritime Expeditionary Security Force Analysis	277
A.3.3.1.	<i>Organization</i>	277
A.3.3.2.	<i>Mission Decomposition</i>	278
A.3.3.3.	<i>Operations</i>	279
A.3.3.4.	<i>Roles</i>	280
A.3.3.5.	<i>Operational Limitations</i>	280
A.3.3.6.	<i>Environment</i>	281
A.3.3.7.	<i>Threats</i>	281
A.4.	POTENTIAL NECC APPLICATIONS TO 2030 JOINT UMS ARCHITECTURE	282
A.4.1.	Riverine Force	282
A.4.2.	Naval Construction (SEABEES)	282
A.4.3.	Explosive Ordnance Disposal	282
A.4.4.	Maritime Expeditionary Security Force	283
A.4.5.	Expeditionary Intelligence	283
A.4.6.	Expeditionary Logistics	283
A.4.7.	Maritime Civil Affairs	283
A.4.8.	Security Force Assistance	283
A.4.9.	Combat Camera	284
A.4.10.	Expeditionary Combat Readiness	284
A.5.	OPERATIONAL SCENARIOS	284
A.5.1.	OPSIT 1: Oil Platform (OILPLAT) Protection	284
A.5.2.	OPSIT 2: RIVERINE PATROL	289
APPENDIX B	UNMANNED SYSTEMS RESEARCH	294
B.1.	HISTORICAL MILITARY USAGE OF UMS	294
B.2.	UNMANNED AERIAL VEHICLES	296
B.2.1.	Current Unmanned Aerial Vehicles	296
B.2.1.1.	<i>MQ-1 Predator (General Atomics Aeronautical Systems)</i>	296
B.2.1.2.	<i>MQ-9 Reaper (General Atomics Aeronautical Systems)</i>	299

	<i>B.2.1.3. ScanEagle (Insitu/Boeing)</i>	300
	<i>B.2.1.4. RQ-11B Raven</i>	302
	<i>B.2.1.5. Wasp III (AeroVironment)</i>	304
	<i>B.2.1.6. Desert Hawk (Lockheed Martin)</i>	305
	<i>B.2.1.7. MD4-200 (Microdrone)</i>	307
	<i>B.2.1.8. T-Hawk/gMAV (Honeywell)</i>	308
	<i>B.2.1.9. Aerosonde (AAI Corporation)</i>	309
	<i>B.2.1.10. FINDER (Naval Research Laboratory)</i>	311
	<i>B.2.1.11. RQ-7 Shadow (AAI)</i>	313
	<i>B.2.1.12. Heron (Israeli Aerospace Industries)</i>	314
	<i>B.2.1.13. Hermes 450/Watchkeeper (Elbit Systems)</i>	315
	<i>B.2.1.14. MQ-5 Hunter (Northrup Grumman)</i>	316
	<i>B.2.1.15. RQ-4 Global Hawk (Northrop Grumman)</i>	317
B.2.2.	Future Unmanned Aerial Vehicles	318
	<i>B.2.2.1. Phantom Ray (Boeing Company)</i>	<i>318</i>
	<i>B.2.2.2. Demon BAE Systems</i>	<i>320</i>
	<i>B.2.2.3. Vulture Jim (Lockheed Martin)</i>	<i>321</i>
	<i>B.2.2.4. RQ-170 Sentinel (Lockheed Martin)</i>	<i>322</i>
	<i>B.2.2.5. Embla (Aesir)</i>	<i>323</i>
	<i>B.2.2.6. Ion Tiger (Naval Research Laboratory)</i>	<i>324</i>
	<i>B.2.2.7. Excalibur McArdle Productions</i>	<i>326</i>
	<i>B.2.2.8. S-100 Camcopter (Schiebel)</i>	<i>328</i>
	<i>B.2.2.9. Skylite (BAE Systems)</i>	<i>329</i>
	<i>B.2.2.10. MANTIS (BAE Systems)</i>	<i>331</i>
	<i>B.2.2.11. Predator-C Sea Avenger (General Atomics)</i>	<i>333</i>
	<i>B.2.2.12. Zephyr (QinetiQ)</i>	<i>334</i>
	<i>B.2.2.13. HALE (High Altitude Long Endurance) (Boeing)</i>	<i>335</i>
	<i>B.2.2.14. Global Observer (AeroViroment)</i>	<i>336</i>
	<i>B.2.2.15. Samarai (Lockheed Martin)</i>	<i>338</i>
B.3.	UNMANNED SURFACE VEHICLES	340
	B.3.1. Protector (Rafael/BAE Systems)	340
	B.3.2. Antisubmarine Warfare Unmanned Surface Vehicle	341
	B.3.3. Mine Counter Measures (MCM)	342
	B.3.4. SEAFOX	343
B.4.	UNMANNED UNDERWATER VEHICLES	344
	B.4.1. Remus (Hydroid Inc)	344
	B.4.2. Battlespace Preparation Autonomous Undersea Vehicle (BPAUV) (Naval Research Laboratory)	345
	B.4.3. Littoral Battlespace Sensing – Autonomous Undersea Vehicle (LBSAUV)	346
	B.4.4. Bottom Unmanned Undersea Vehicle (UUV) Localization System (BULS)	347
B.5.	UNMANNED GROUND VEHICLES	348
	B.5.1. UGV Light	348
	<i>B.5.1.1. Soldier UGV (SUGV)</i>	<i>348</i>

B.5.1.2.	<i>Combined Operations Battlefield Robotic Asset (COBRA)</i>	348
B.5.1.3.	<i>Man Transportable Robotic System (MTRS)</i>	349
B.5.1.4.	<i>Dragon Runner</i>	350
B.5.1.5.	<i>Mesa Associates' Tactical Integrated Light-Force Deployment Assembly (MATILDA)</i>	351
B.5.2.	UGV Medium	352
B.5.2.1.	<i>Metal Storm</i>	352
B.5.2.2.	<i>Remote Detection, Challenge, and Response System (REDCAR) (ARFL)</i>	353
B.5.2.3.	<i>Gladiator Tactical Unmanned Ground Vehicle</i>	354
B.5.2.4.	<i>Mobile Detection Assessment and Response System (MDARS)</i>	355
B.5.2.5.	<i>Remote Ordnance Neutralization System (RONS)</i>	356
B.5.3.	UGV Heavy	357
B.5.3.1.	<i>CAT (Crew-integration and Automation Test-bed)</i>	357
B.5.3.2.	<i>Cooperative Unmanned Ground Attack Robots (COUGAR)</i>	359
B.5.4.	UGV Large	361
B.5.4.1.	<i>Automated Ordnance Excavator (AOE)</i>	361
B.5.4.2.	<i>CRUSHER</i>	362
B.6.	UNMANNED OUTER SPACE VEHICLES	363
B.6.1.	<i>Space X-37B (Boeing)</i>	363
	INITIAL DISTRIBUTION LIST	366

LIST OF FIGURES

Figure 1.	Broad Deliverables & Key Principle Considerations	8
Figure 2.	Systems Engineering “Vee” Model	12
Figure 3.	SEA-16 Modified “Vee” Model	14
Figure 4.	Characterization of Current Command and Control Relationships	24
Figure 5.	Overview of the 2030 Joint Command and Control Architecture Concept.....	29
Figure 6.	Goals and Objectives of the System	31
Figure 7.	Boyd's OODA Loop.....	48
Figure 8.	Missions of Unmanned Systems.....	51
Figure 9.	Categories of Unmanned Aerial Vehicles.....	52
Figure 10.	Classes of Unmanned Ground Vehicles	53
Figure 11.	Classes and Missions of Unmanned Surface Vehicles	54
Figure 12.	Parameters of Four Classes of Unmanned Underwater Vehicles	55
Figure 13.	Aspects of the ALFUS Framework.....	58
Figure 14.	ALFUS Characteristics	59
Figure 15.	ALFUS vs Bandwidth.....	61
Figure 16.	ALFUS Simplification	65
Figure 17.	Fitts’ List.....	67
Figure 18.	DoD-Identified Functions Where Humans Excel.....	68
Figure 19.	DoD-Identified Functions Where Machines Excel.....	69
Figure 20.	Price’s Comparison Methodology for Allocating Roles to Humans or Machines.....	72
Figure 21.	Example of Current UMS System Decision Tree.....	74
Figure 22.	Human Control vs. Computer Judgment	76
Figure 23.	Comparison of Simple & Combined Cycles.....	88
Figure 24.	The Pulse Detonation Engine Cycle	90
Figure 25.	Comparison of Humphrey and Brayton Cycles.....	91
Figure 26.	Extrapolation of Engine Cycle Efficiency	93
Figure 27.	Projected U.S. Reliance on Petroleum Imports	95
Figure 28.	Prediction of Energy Content of Future Fuel.....	97
Figure 29.	Comparison of Fuel Cell Technology.....	102
Figure 30.	Endurance Increases by 2030 for the Predator & Global Hawk UAV's.....	104
Figure 31.	Developing Functional Architecture.....	112
Figure 32.	Decomposition Process.....	113
Figure 33.	Manage UV Operations Hierarchy Diagram	115
Figure 34.	Manage UV Operations FFBD	116
Figure 35.	Manage UV Operations IDEF A-0 Context Diagram.....	117
Figure 36.	Manage UV Operations Input/Output Diagram.....	119
Figure 37.	Provide C2 Hierarchy Diagram	131
Figure 38.	Provide C2 FFBD	135
Figure 39.	Monitor System Item Flow	139
Figure 40.	Orient Item Flow.....	140
Figure 41.	Understand Situation Item Flow	142
Figure 42.	Decide Item Flow.....	144

Figure 43.	Determine COA Item Flow.....	145
Figure 44.	Analyze COA Item Flow.....	146
Figure 45.	Act Item Flow.....	147
Figure 46.	Command Asset Item Flow.....	149
Figure 47.	Collaborate Hierarchy.....	150
Figure 48.	Collaborate FFBD.....	152
Figure 49.	Collaborate Item Flow.....	155
Figure 50.	Manage Data Item Flow.....	158
Figure 51.	Conduct UV Operations Hierarchy.....	160
Figure 52.	Conduct UV Operations FFBD.....	163
Figure 53.	Conduct UV Operations Item Flow.....	166
Figure 54.	Operate Sensors Item Flow.....	168
Figure 55.	Operate UV Item Flow.....	170
Figure 56.	OV-1 High Level Operational Concept Graphic.....	180
Figure 57.	Protective Operation.....	181
Figure 58.	Search Operation.....	183
Figure 59.	Information Exchange Model for Command and Control.....	185
Figure 60.	Operational Activity Model (OV-5) for Force Protection.....	193
Figure 61.	Operational Activity Model (OV-5) for Reconnaissance.....	194
Figure 62.	High Level Conceptual System View.....	195
Figure 63.	Global Coverage.....	198
Figure 64.	Local Coverage.....	199
Figure 65.	High Altitude Platform Stations (HAPS).....	201
Figure 66.	Access HAPS.....	201
Figure 67.	Underwater Application of System.....	204
Figure 69.	TCR plot (Range Resolution 3.3m, UAV=5000ft, Missile=30m, X band, (SS 0,2,3)).....	213
Figure 70.	Plot of Sea backscatter coefficients vs Grazing angle.....	215
Figure 71.	TCR vs Range (Range Resolution 3.3m, UAV=5000ft, Missile=30m, X band, (sea state 2)).....	216
Figure 72.	Early Warning Screen of UAVs.....	218
Figure 73.	Geometric Analysis of Early Warning Screen.....	219
Figure 74.	Sample Scheduling of UAVs for a Single Aerial Picket Station.....	222
Figure 75.	Event Graph for the Scheduling Model in SimKit.....	224
Figure 76.	Surface Plot of Variation of Fleet Size.....	227
Figure 77.	Box Plots of Fleet Size Means and Standard Deviations Size.....	228
Figure 78.	Box Plots of Fleet Size Means and Standard Deviations Size.....	229
Figure 79.	Data traffic generated for every missile entering the Detection Zone.....	232
Figure 80.	Unmanned Sensor Network Topology (Extended Range).....	233
Figure 81.	Fade Margin (dB) is inversely proportional to R^2 as the R between Transmitter & Receiver increases.....	237
Figure 82.	Probability of bit error (BER) vs E_b/N_0	238
Figure 83.	NECC Mission.....	264
Figure 84.	Stated Needs of NECC.....	266
Figure 85.	EOD Team Deployment.....	273

Figure 86.	EOD Land CONOPS	275
Figure 87.	EOD Land CONOPS	277
Figure 88.	Functional Decomposition of MESF Missions.....	279
Figure 89.	OILPLAT Input/Output Trace Diagram 1	287
Figure 90.	OILPLAT Input/Output Trace Diagram 2	287
Figure 91.	OILPLAT Input/Output Trace Diagram 3	288
Figure 92.	OILPLAT Input/Output Trace Diagram 4	288
Figure 93.	RIVERINE Input/Output Trace Diagram 1	291
Figure 94.	RIVERINE Input/Output Trace Diagram 2	292
Figure 95.	RIVERINE Input/Output Trace Diagram 3	292
Figure 96.	General Atomics MQ-1 Predator UAV	297
Figure 97.	General Atomics Reaper MQ-9 UAV.....	299
Figure 98.	Insitu/Boeing ScanEagle.....	300
Figure 99.	Insitu/Boeing ScanEagle.....	301
Figure 100.	RQ-11B Raven.....	302
Figure 101.	AeroVironment Wasp III.....	304
Figure 102.	Lockheed Martin Desert Hawk.....	305
Figure 103.	Microdrone MD4-200.....	307
Figure 104.	Honeywell T-Hawk/gMAV.....	308
Figure 105.	AAI Corporation Aerosonde.....	309
Figure 106.	NRL FINDER.....	311
Figure 107.	AAI RQ-7 Shadow.....	313
Figure 108.	Israeli Aerospace Industries Heron.....	314
Figure 109.	Elbit Systems Hermes 450/Watchkeeper.....	315
Figure 110.	Northrup Grumman MQ-5 Hunter.....	316
Figure 111.	Northrup Grumman RQ-4 Global Hawk	317
Figure 112.	Boeing Phantom Ray	318
Figure 113.	BAE Systems Demon	320
Figure 114.	Lockheed Martin Vulture Jim.....	321
Figure 115.	Lockheed Martin RQ-170 Sentinel.....	322
Figure 116.	Aesir Embla	323
Figure 117.	NRL Ion Tiger.....	324
Figure 118.	McArdle Productions Excalibur	326
Figure 119.	Schiebel S-100 Camcopter.....	328
Figure 120.	BAE Systems Skylite.....	329
Figure 121.	BAE Systems MANTIS.....	331
Figure 122.	General Atomics Predator C Sea Avenger UAV	333
Figure 123.	QinetiQ Zephyr	334
Figure 124.	Boeing HALE	335
Figure 125.	AeroVironment Global Observer.....	336
Figure 126.	Lockheed Martin Samarai.....	338
Figure 127.	Rafael Protector	340
Figure 128.	Antisubmarine Warfare Unmanned Surface Vehicle	341
Figure 129.	Mine Counter Measures (MCM)	342
Figure 130.	SEAFOX.....	343

Figure 131.	Hydroid Inc. Remus	344
Figure 132.	NRL Battlespace Preparation Autonomous Undersea Vehicle (BPAUV)	345
Figure 133.	Littoral Battlespace Sensing – Autonomous Undersea Vehicle (LBSAUV).	346
Figure 134.	Bottom Unmanned Undersea Vehicle (UUV) Localization System (BULS).....	347
Figure 135.	Dragon Runner.....	350
Figure 136.	Mesa Associates’ Tactical Integrated Light-Force Deployment Assembly (MATILDA)	351
Figure 137.	Metal Storm Talon UGV	352
Figure 138.	ARFL Remote Detection, Challenge, and Response System (REDCAR)	353
Figure 139.	Gladiator	354
Figure 140.	Mobile Detection Assessment and Response System (MDARS).....	355
Figure 141.	Remote Ordnance Neutralization System (RONS).....	356
Figure 142.	Crew-integration and Automation Test-bed (CAT).....	357
Figure 143.	Cooperative Unmanned Ground Attack Robots (COUGAR).....	359
Figure 144.	Automated Ordnance Excavator (AOE)	361
Figure 145.	CRUSHER	362
Figure 146.	Boeing X-37B	363
Figure 147.	Boeing X-37B	364

LIST OF TABLES

Table 1.	SEA-16 Matrix OrganizationChart	16
Table 2.	Technology Assumptions.....	27
Table 3.	Military Assumptions.	28
Table 4.	Stakeholder Analysis.2.11. factors for design	39
Table 4.	2.11. factors for design.....	40
Table 5.	Numbers of Named UMs.....	50
Table 6.	ALFUS Levels 5-10.....	63
Table 7.	ALFUS Levels 0-4.....	64
Table 8.	Sources of Human and Mechanical Error.....	70
Table 9.	Strengths of Humans and Machines Related to Boyd’s OODA Loop.....	71
Table 10.	U.S. Military Jet Fuel Loop.	94
Table 11.	Bio-Fuel to Jet Fuel Comparison.	96
Table 12.	Battery Technology Comparison.....	98
Table 13.	UAV Performance Prediction for Year Milestones - Engine Efficiency Only.....	103
Table 14.	UAV Performance Prediction for Year Milestones - Engine and Fuel Efficiency.....	103
Table 15.	Manage UV Operations Hierarchy.	121
Table 16.	Functions and Input/Outputs Definitions.....	129
Table 17.	Provide C2 Input/Output.....	138
Table 18.	Collaborate Input/Output.	154
Table 19.	Conduct UV Operations Input/Output.....	165
Table 20.	Functional Measures of Effectiveness.	175
Table 21.	MS / UV (Master)-to-HQ Information Exchange.....	187
Table 22.	HQ-to-UV (Master) Information Exchange.....	189
Table 23.	HQ-to-MS Information Exchange.	190
Table 24.	UV (Master)-to-UV (Subordinate) Information Exchange.....	190
Table 25.	UV (Subordinate)-to-UV (Master) Information Exchange.....	191
Table 26.	Variation of k UAVs with R_d and $T_{min,1}$	221
Table 27.	Fleet Size Variation with Detection Range and Coverage Overlap.	227

THIS PAGE INTENTIONALLY LEFT BLANK

EXECUTIVE SUMMARY

Introduction

U.S. Forces will require a Command and Control (C2) Architecture enabling the coordinated operations of manned and unmanned systems by the year 2030. The year 2030 was chosen for the scope of the project because the technology necessary for our architecture will be available in one or two design cycles beyond our current capability. When existing C2 structures are unable to keep up with operational requirements for large numbers of manned and unmanned systems, a new C2 architecture capable of meeting this requirement will be required. The purpose of this project is to develop the concepts for a new architecture based on operational needs. We developed an architectural concept that identifies the functional and operational aspects that will be necessary to realize an integrated manned and unmanned conceptual architecture by the year 2030.

Our Approach

The systems engineering approach was to:

- Differentiate the task statement of manned and unmanned systems based on time to perform task
- Develop concepts of operations and key operational scenarios
- Perform consequence analysis
- Identify stakeholders
- Determine key design drivers/ requirements
- Identify capability gaps
- Suggest key technology focus areas
- Propose future studies to achieve our conceptual architecture

Two missions, force protection and reconnaissance, were chosen because they are common to all forces in their day to day operations. Focusing on these two missions facilitated the development of the functions, operational activities, operational nodes, and information exchanges necessary to develop the C2 architecture concept.

High Value Unit (HVU) protection is a vital function for commanders in all military services at all levels. In 2030, HVU protection will become even more difficult due to the advances in adversarial capabilities. For this scenario, the advantage of utilizing unmanned aerial vehicles was modeled to extend the range of detection for a highly capable Anti-Ship Cruise Missile (ASCM). We assume that in the year 2030 this ASCM threat will be capable of increased speeds of Mach 4+, with reduced radar cross-section and low flight profile.

This model depicts defense of a Carrier Battle Group (CVBG) using an extended ring of detection provided by unmanned systems. Additionally, this model can be applied to other joint situations, including the protection of land-based assets.

Project Organization

A matrix organization type format was used to coordinate the efforts of all team members utilizing Integrated Project Team for specific tasking and Track Teams for specific expertise. These organizational teams conducted a detailed analysis of the project tasking and scoped the project into three essential deliverables:

- Produce a coherent Vision of unmanned vehicles
- Develop a Joint Systems vehicles concept
- Design a Command and Control (C2) Architecture

Following the scoping of the project a Systems Engineering Process Model was developed in order to schedule and plan the project to completion. The process model was composed of four phases: Project Definition, Systems Analysis, Preliminary Design, and System Design for Utility.

Concept of Operations

A Concept of Operations was developed in order to define and focus the architectural concept for the project. The Overview of the Envisioned System, as shown below, demonstrates the robust collaboration of data sharing required to disseminate information across the battlespace. Manned and unmanned systems will operate under a single architecture allowing any node within the system to exploit the collective knowledge of all nodes to execute the mission. An open architecture with common interfaces will allow coalition forces or governmental agencies to fully integrate with U.S. forces.

U.S. forces will increasingly use unmanned systems (UMS) as force multipliers. As unmanned systems become more productive and more predominant in the battlespace, human participation will gradually decrease. UMS will provide increased opportunities to reduce human presence in dangerous environments. Due to the increase in UMS a collaborative network will be required to manage these assets. Common interfaces within this architecture will enable system interoperability between manned and unmanned systems.

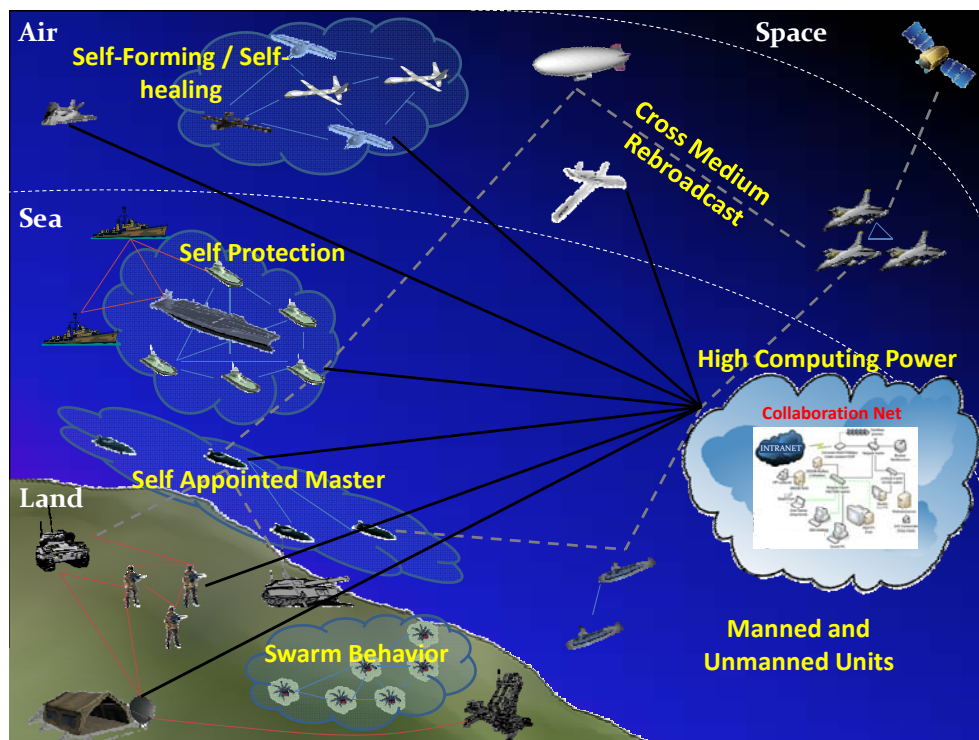

Consequence Analysis

A high level risk assessment, or consequence analysis, was conducted looking at the possible results of failing to act in establishing this architecture.

- Decrease in situational awareness due to information overload
- Reactive implementation of Unmanned Systems management
- Immature technology development causes an inability to integrate systems
- United States will fall behind technological rivals

Stakeholder Analysis

Two main categories of stakeholders for this project were developed; interested and affected organizations. Interested Organizations are those groups that have expressed actual interest or provided input while affected organizations are those groups that, while not expressing interest in the project, would be highly affected by the outcome. In the table, on the following page, the “x” in the block denotes where the organization has an interest in the function category, the capabilities category, or both. Our first primary sponsor N8F has priorities in the acquisition function. Naval Expeditionary Combat Command (NECC) has priorities in the capabilities category of Communication (COMMS); Intelligence, Reconnaissance, and Surveillance (ISR); and Force Protection.

	Stakeholder Interest(s) in the Project	Assessment of Impact	FUNCTIONS				CAPABILITIES								
			Acquisition	Management	Logistics	Operator	COMMS	ISR	Strike	Force Protection	EW	Maritime Warfare	Land Warfare	Transport	Air Warfare
Interested Organizations															
Navy Expeditionary Combat Command	H	H		X		X	X	X		X	X	X	X		X
Naval Undersea Warfare Center Newport	M	M		X	X	X	X	X		X	X	X		X	
Unmanned Surface Vehicles (PMS-403)	M	H	X	X	X		X	X		X	X	X		X	X
Naval Oceanography MIW Center	M	M		X		X	X	X		X		X			
Naval Surface Warfare Center	M	M	X	X	X	X	X	X	X	X	X	X		X	X
Littoral and Mine Warfare (PMS-420)	M	H	X	X	X		X	X	X	X	X	X		X	X
Office of Naval Research	L	L		X			X	X	X	X	X	X	X		X
Jet Propulsion Laboratory	L	M		X			X		X	X	X	X		X	X
OPNAV N-8F	L	M	X	X											
OPNAV N-857	M	M	X	X	X		X	X	X	X	X	X		X	X
OPNAV N2/N6	L	M	X	X			X	X	X	X	X	X			X
Naval Postgraduate School	M	M		X			X	X	X	X	X	X	X	X	X
UUV Advanced Development	L	H		X			X	X		X		X			
PEO LMW (PMS-495)	M	M	X	X	X		X	X		X	X	X			
PEO (U&W), NAVAIR	L	M	X	X	X		X	X	X	X	X	X	X	X	X

Command and Control

The Command and Control architecture enables knowledge sharing and the execution of an expanded Boyd’s Observe, Orient, Decide and Act (OODA) Loop. The Functional Decomposition of Command and Control (Section 4.1) was used to develop (1) the basic functions required for UMS and (2) an extensive assessment of UMS mission domain.

Autonomy and Man in the Loop

An assessment of autonomy was conducted in order to characterize the Human Robot Interface (HRI), Mission Complexity, and Environmental Complexity of the mission space for UMS. SEA-16 used the ALFUS (Autonomous Levels for Unmanned Systems) as developed by the National Institute of Standards and Technology. In the figure shown on the next page, a simplified model of three autonomy levels (Low,

Medium, and High) was used during the simulation phases. Each of the three phases was defined by the amount of Human Interaction (HI), Mission Complexity (MC) and Environmental Complexity (EC).

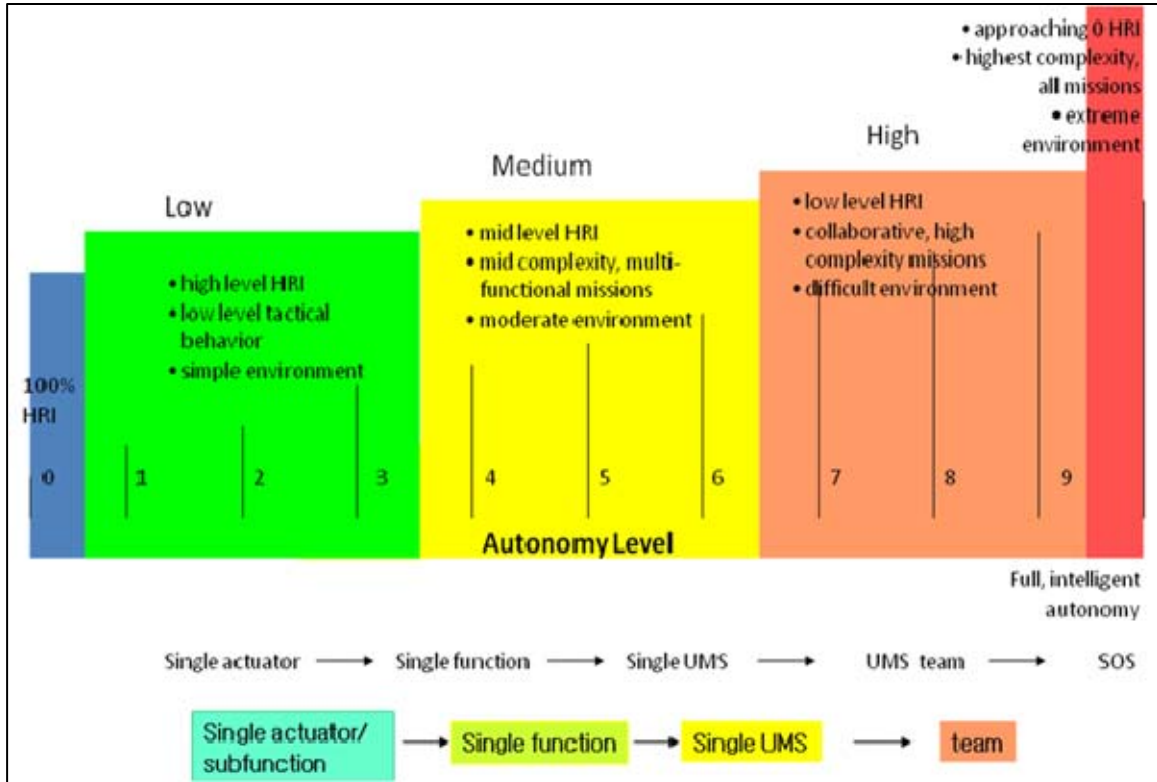

Additionally, an assessment of Man in the Loop was conducted to characterize the role of humans and machines within the mission domain. This assessment allowed for an understanding of strengths and weaknesses contrasting humans and machines.

Engineering Assessment

Trade studies were conducted to explore the areas most beneficial to UMS. Factors that were evaluated included: engine cycle efficiency, advanced fuels, and fuel cell/battery power systems. We feel that the current efficiency trends in sustainable and emission friendly resources will continue to be financial and technological drivers for the future force structure. The Engineering Assessment of capabilities for UMS

provided the key inputs for multiple phase modeling, where application of future technology demonstrated longer endurance for UMS on-station time.

Functional Architecture

The purpose of this architecture is to describe the integration of unmanned and manned vehicles in all domains into a collaborative knowledge sharing environment, allowing for unity of effort amongst all the warfare tools in the battlespace. The functional architecture contains a hierarchical model of the functions performed by the system, functional flow block diagrams, and diagrams showing the functional inputs and outputs. This architecture includes the interfaces between UMS, C2 nodes, manned operational units, and external systems. The unique aspect of this concept is that the architecture, while focused toward unmanned vehicles, also takes into account the integration of manned vehicles through the collaborative network. The principal exchange of information is through a collaborative network which acts a data fusion network that is distributed across the forces.

Modeling

We applied the architecture concepts to one of the innumerable potential operational applications for unmanned vehicles. Our model depicted the deployment of unmanned vehicles to provide the carrier battle group with early detection of an Anti-Ship Cruise Missile (ASCM). This analysis began with a determination of the UAV fleet size required to provide an ASCM early warning screen.

Some key assumptions were made for the analysis

- Benign environment
 - Sea States are between 0 to 3
 - No Enemy Jamming or EW countermeasures
 - No UAV to UAV engagements
- ASCM RCS of 0.1 to 1 m²

- ACSM speed of Mach 4+
- Probability of Detection assumed to be 1
- Continuous track handling capability of a detected ASCM
- Detection to Firing Time a constant 10 seconds
- Maximum UAV patrol time approximately 45 hours
- Repair time on failure of a UAV based on triangular distribution of 4 to 8 hours, with a mode of 5 hours
- Maintenance time after mission completion based on triangular distribution of 0.8 to 2 hours, with a mode of 1
- The cumulative total time of flight before the UAV encounters a non-catastrophic failure is assumed to be a normal distribution of mean 200 hours and standard deviation of 60.79
- Mean Time Between Failure (MTBF) of UAVs of 200 hours
- 5% probability that the Time To Fail (TTF) will be below 100 hours of operation

The geometric force layout was determined based on several parameters, specifically, a surface detection range of 60km, UAV detection range of 30km, a scanning angle of 100°, and desired continuous UAV radar coverage overlap for a Mach 4+ missile of 1-4 sec.

Modeling Phase II determined that a fleet size of 21±1 UAVs is required to achieve the persistent early warning screen, given UAV detection range of 30km and UAV radar coverage overlap of 1 sec. For a conservative fleet size estimate, given the uncertainties of the coverage overlap and radar detection range, a fleet size of 35 should be anticipated given UAV detection range of 20km and UAV radar coverage overlap of 4 sec.

Summary of Results

A joint C2 architecture for manned and unmanned systems based on Boyd's OODA Loop approach is necessary by the year 2030. Development of such architecture will allow for large numbers of manned and unmanned nodes to operate within a single C2 structure. Information sharing, provided by a collaborative information network that is unbounded by physical media, mission capabilities, or geographic location, will improve unity of effort.

THIS PAGE INTENTIONALLY LEFT BLANK

ACKNOWLEDGMENTS

The SEA-16 Integrated Project Team would like to thank the faculty and staff of the Wayne E. Meyer Institute of Systems Engineering for their commitment to our academic development and the completion of this integrated project.

We want to thank our faculty advisor who worked tirelessly to provide guidance and support throughout this project. Professor Gary Langford developed our understanding of Systems Engineering principles and encouraged creative analysis of the problem.

RADM (ret) Rick Williams and CAPT (ret) Professor Chuck Calvano provided us a fleet perspective on the project and found multiple opportunities for us to contact leading professionals in the development of unmanned vehicles and other defense systems.

Each academic track of students in this project benefitted from the experience and guidance of their faculty advisors, specifically Professor Dave Meyer, Operation Research and Modeling & Virtual Environment Simulation Track Advisor; Professor Peter Ateshian, Communication, Sensor & Network Track Advisor; Professor Karen Burke, Information Assurance Track Advisor; and Professor Chris Brophy, Weapons Track Advisor.

We would like to recognize our military advisor, CDR Douglas Burton, USN, for his persistent interest in our academic progress and his personal efforts to ensure a positive professional experience at NPS.

We wish to acknowledge the support of our NPS instructors, who provided a tremendous educational experience that supported the concepts presented in this project.

These instructors include:

LTC Mark Stevens, USA (ret)

Professor Doyle Daughtry

COL David Matthews, USA (ret)

Professor Paul Sanchez

Professor Gregory Miller

Professor David Hart

Professor William Solitario

LTC Terry Smith, USAF

Professor James Eagle

LTC Robert Shearer, USA

Professor Matthew Boensel

Professor Edouard Kujawski

CAPT Wayne Hughes, USN (ret)

CAPT Douglas Otte, USN

CAPT Jeffrey Kline, USN (ret)

Professor Thomas Hoivik

Professor Rachel Goshorn

Professor Robert Harney

Professor Daniel Nussbaum

Professor Kristin Giammarco

We would like to thank the Associates of Temasek Defence Systems Institute (TDSI) for their invaluable advice to the TDSI students back in Singapore. Joseph Kasser, D.Sc. visiting associate professor in the National University of Singapore, helped the students to examine aspects of the integrated project tasking that require further clarifications. Mr. Lim, Horng Leong, Principal Engineer in the Singapore Defense Science & Technology Agency shared his experience as a member of SEA-11.

We would also wish to thank many individuals for their contributions to the integrated project. These include Professor Arnold Buss, for assisting in the review and guidance on the development of the event graph and SimKit model, and Professor Nita Miller and LTC Anthony Tvaryanas, USAF, for sharing of their views and experience in human factors in a complex environment and suggestion of future research.

We would like to acknowledge Ms. Barbara Berlitz and Ms. Katie Oropeza for their tremendous administrative and technical support throughout this project.

Finally, we want to thank our families for their dedication and support through the duration of our program and for their selfless support of the NPS and Monterey communities.

THIS PAGE INTENTIONALLY LEFT BLANK

1.0. INTRODUCTION

1.1 PROJECT BACKGROUND

Changing tactics and missions of the battlefields has challenged the Command and Control (C2) of combat throughout the history of warfare. In the battlefields of the past, the commander relied on message runners and voice commands. Messages could take weeks to months to cross a continent or ocean. Technology supports the modern battlefield commander by providing global reach with command only a few seconds delay. Today's commander can exercise command and control, albeit fundamentally, it is the modern application of the C2 of yesterday which he must use to determine a course of action. The commander must overcome the ambiguity during military operations to analyze a situation, make a decision, and direct forces. Given a parity of resources and capabilities, the commander that makes and carries out a correct decision before his adversary will be at an advantage.

“We need for unmanned aircraft to act like manned aircraft.

We need unmanned aircraft to be tasked like manned aircraft.

We should be capable of flying both manned and unmanned platforms together, to include multiple unmanned airframes controlled by one operator,” the general continued. “And we need commanders to have the confidence that unmanned or manned, it doesn't make a difference, as they are equally effective,”¹

-Gen. William T. Hobbins, USAF (2006)

The primary task of this integrated project is to design an overarching C2 architecture concept for manned and unmanned vehicles operating in a 2030 battlespace. Systems Engineering and Analysis Cohort 16 (SEA-16) is not

¹ “Unmanned Aircraft Key to Future Operations, General Says” American Forces Press Service <http://www.defense.gov/News/NewsArticle.aspx?id=1730>, accessed 17 May 2010.

attempting to redefine C2; rather application of proven C2 fundamentals is necessary to develop an architecture which integrates manned and unmanned vehicles in the air, land, sea, undersea, space domains. The C2 cycle used in the development of our concept is Boyd's OODA Loop (Observe, Orient, Decide, and Act), as further decomposed in [Section 3.1](#).

We successfully showed in this project that a future Command and Control architecture can integrate the many elements of the strategic, operational, and tactical elements of the U.S. and Coalition partners. Regardless of the platform or tool that is executing the commander's orders, we showed a C2 architecture that allows for quality decisions to be executed inside the adversary's decision making cycle.

1.2. FUTURE STAKEHOLDERS

Advances in missile technology have Anti-Ship Cruise Missiles (ASCM) speeds increasing towards the Mach 6+ threshold. The application of this technology necessitates the application of all available technology to counter these high speed threats. Therefore, the main consequence of not instituting the architecture developed in this project is that defensive measures for High Value Units (HVV) (aircraft carriers, strategic buildings, command posts, etc) utilizing current defensive systems, weapons, and tactics will be limited to one, or maybe no reactive launches.

This limitation of defensive measures was a fundamental consideration in the stakeholder analysis conducted in this project. The highest level stakeholders detailed in [Section 2.10](#), are those organizations that have the long-term vision essential in order to implement the proposed architecture within this project.

1.3. PROJECT TASKING

1.3.1. Systems Engineering and Analysis (SEA) Tasking Statement

The tasking statement designated in SEA-16 Capstone Project Objectives Memorandum stated:

“Develop a Joint Systems concept and supporting architecture that supports the integration and utilization of Unmanned Vehicles into the Navy Fleet Structure, focused on NECC [Naval Expeditionary Combat Command] missions. Consider current and evolving unmanned technologies to develop a complete architecture that is flexible to emerging unmanned technologies. Design a C2 [Command and Control] architecture with a possible common control system. Reassess the current utilization of manned and unmanned vehicles in seeking a reduction in architectural complexity, and determine alternative uses of those resources. Considering potential technology gaps, determine a more streamlined architecture with gap fillers. Focus on the development of a system of systems and family of systems in support of the NECC enterprise. Consider focused mission areas per platform to concentrate mission tasking, promote specialization of manning, and shrink force structure. Iterate the task nature, as approved by your primary faculty advisor, Prof. Langford. Produce a coherent vision of unmanned vehicles in support of NECC tasks and identify the requirements for supporting or collaborating forces.”²

² SEA-16 CAPSTONE PROJECT OBJECTIVES, 03 September 2009

1.4. SCOPING

The SEA-16 Integrated Project Team scoped this problem by decomposing the Tasking Statement and building on those with key considerations. These concepts were mapped to the three key deliverable items for the overall project. These deliverables are:

- Produce a coherent vision of unmanned vehicles
- Develop a Joint Systems vehicles concept
- Design a Command and Control (C2) Architecture

Figure 1 displays a graphic representation denoting the key considerations with respect to the three identified deliverables (shown in gold bubbles) for this project. Arrows indicate inputs to the deliverables: Vision, Concept, and Architecture.

1.4.1. Tasking Interpretation

1.4.1.1. Tasking Statement Decomposition

Concepts that were extracted from the tasking statement, as shown in black in [Figure 1](#), are outlined below.

Requirement for Coalition Operations The use of coalition partners will be more important in 2030 than it is today. Enhanced interoperability with coalition partners will be possible with an overarching architecture that can be used by both the United States and its allies.

Command and Control Command and Control of all systems in the fleet should be managed under a single architecture. The limitations of the current system inhibits the commander due to the time taken to interpret inputs from separate systems into a coherent evaluation of the situation. Development of an overarching architecture will allow for the streamlining of information inputs and decrease the time for decision making. This could increase commander's situational awareness, allowing them to make more

informed decisions and allow users access to information in order to take proper action.

Reduce Complexity To enhance the situational analysis of the battlespace, there must be an increase in processed data provided to the user. This processed data is essential to the efficient planning of combat operations. Additionally, an overarching architecture would reduce complexity by decreasing the information transfer lag produced by the cross connection of multiple incompatible systems.

Integration and Utilization of UMS in the Navy Fleet Structure
The fleet and force structure of the future will be a combination of manned and unmanned systems. Regardless of the platform providing the information, any operator (manned or unmanned) should have access to all data in order to optimize support to combat operations.

Utilization of UMS (Current Vs Future) The current utilization of UMS must be examined in order to project the potential future mission space. This information will provide an understanding of missions, capabilities, and technological needs to develop the architecture to support these needs. Additionally, future technology, the roles of manned and unmanned systems, and the required levels of autonomy must be understood.

Current Technical Gaps and Potentials Current technology must be evaluated to identify the current gaps that exist in the systems. These gaps can be addressed with potential technology and continued research, in order to design a system that meet the capability needs of the future.

Reduction of Force Structure The use of UMS in the future could aid in reducing the number of personnel on the battlefield. This in one area where time was not committed for further study, but for any future system the cost and number of personnel compared to UMS would need to be evaluated.

1.4.1.2. Project Team Interpretation

Additional concepts identified by the team were items not included in the project tasking statement, but that needed to be addressed in this project. These additional items are shown in red in [Figure 1](#), and outlined below.

Raise, Train and Sustain Authority In the 2030 timeframe, this system must not only be technically realized, but the force must be ready to operate the system as well. Considerations must be made to train users and maintainers to apply this system and maximize its usability.

External Stakeholders An understanding of the system needs requires an examination of stakeholders. These include the function they play in the system as well as the mission capabilities they require. The external stakeholders provide input and receive output from the system. A discussion of the process and results of the needs is shown in [Section 2.10](#) of this report.

Ideal UMS Fleet Structure UMS will be required to operate within the manned fleet structure, and enhance the functional capacity of the force. The relationships between varying nodes within the system must be studied in order to fill the capabilities needed.

Pros and Cons of UMS There are many implications that are tied to the use of UMS. The concept must recognize the strengths and weaknesses of these systems with consideration to the strengths and weaknesses of manned systems.

What problems are solved by UMS? What value is derived from using unmanned vehicles versus manned vehicles? To answer this question, the group assessed societal views on the value of human life, the cost of training a person versus maintaining a machine, and the ease of replacing a machine versus a human. Additionally, the missions were broken down to their essential tasks in order to identify task that are more effectively completed though the use of UMS.

Mission and Roles (with Assumptions) On what missions does it make sense to utilize unmanned systems? The group had to make assumptions based on the potential missions and uses of UMS in the year 2030. The group analyzed missions that could be enhanced through the use of UMS. The group also looked the different facets of those missions and determined what roles UMS would play.

Vertical and Horizontal Linkages This area of study focused on the interactions between nodes in the battlespace. The horizontal linkages are interactions between nodes with similar functions, such as C2 node to C2 node or between UV and UV. The vertical linkages are the interactions between nodes with different functions, such as the C2 node to the operational vehicles. These linkages are valuable because they give insight to the type of information that will need to be shared.

Manned and Unmanned This area of study involved research as to how manned and unmanned forces will need to interact in the accomplishment of future missions. A determination must be made as to whether manned and unmanned forces require separate C2 architectures or should their system's C2 architectures be integrated? To address this issue the group assessed the different roles each manned and unmanned forces would have during the anticipated missions of 2030.

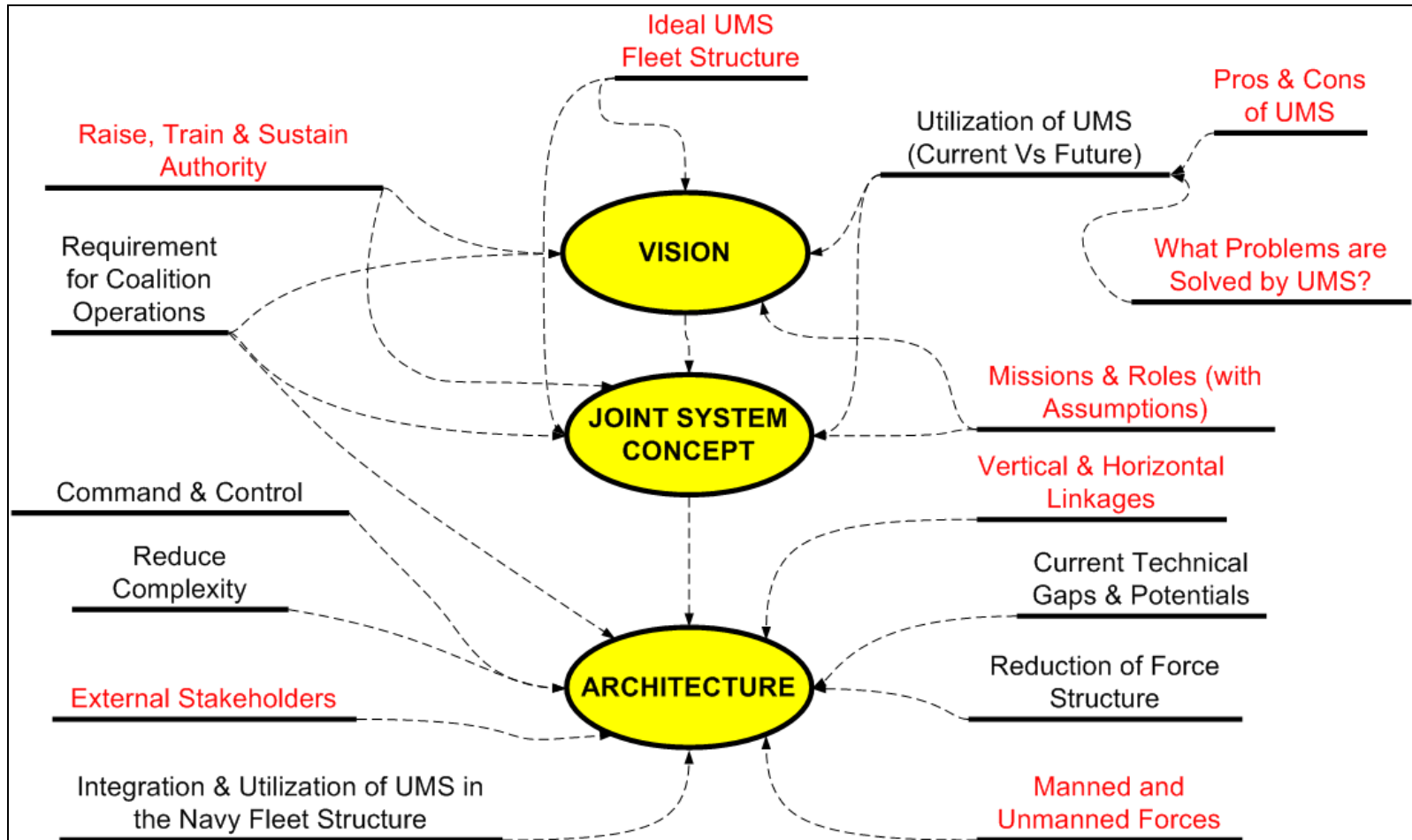

Figure 1. Broad Deliverables & Key Principle Considerations

1.4.2. Project Limitations

Unmanned Systems (UMS) design cycles influenced the timeframe for the project. For the implementation of our concept technology must mature through 2-3 design cycles. This would enable the joint system to be obtainable by the year 2030.

This project focused on U.S. manned and unmanned weapons systems, but acknowledges that collaboration with coalition forces will require analysis of foreign systems as well.

The material in this report is not intended to recommend changes to the organizational layout of the Department of Defense, or imply any specific unit's chain of command relationship.

Inclusion of any development item or current platform in this report does not imply endorsement for acquisition of that specific system.

Personnel allocation will be considered in general terms, and no specific personnel requirements will be determined.

A brief survey was conducted to examine the legal issues associated with the general operation of UMS. These topics were limited to: International Laws, Law of Armed Conflict, United Nations' Convention on the Laws of the Sea (UNCLOS), International Civil Aviation Organization (ICAO), National Sovereignty, and Issues within the United States. These topics were addressed due to their direct correlation to the operation of UMS. Additionally, this report does not attempt to determine who is legally responsible for actions conducted by autonomous vehicles.

A full cost analysis of the system would be required in a future study of this proposed concept.

This project did not include a cost estimate for a fully autonomous system. Much of the technology is still theoretical and the physical composition and bounds of the enabling system are not described in specific terms. There are

two specific cost consideration categories: human costs (including training, human system integration, and salary and entitlements) and machine costs (lines of code, software maintenance, software upgrades, and other costs).

Analysis was not conducted on specifics concerning air space management, water space management, or frequency management.

1.5. SYSTEMS ENGINEERING PROCESS

1.5.1. Development of Systems Engineering Process Model

Initially, the Systems Engineering (SE) Track Team Members developed a list of tasks required to formally develop a systems engineering process. Below is a list of the main tasks required:

- Problem Definition
- Factors for Design
- Trend Analysis
- Development of Assumptions for both Military and Technology
- Needs Analysis
- Review of Current C2 process regarding unmanned systems.
- Develop a Conceptual C2 Process for the year 2030
- Capabilities Analysis
- Gap Analysis
- Stakeholder Analysis
- Risk Assessment
- Development of Scenarios
- Decomposition of Command and Control
- Functional Decomposition
- Methods of Analysis
- Develop Modeling/ Simulation

1.5.2. Systems Engineering “Vee” Process

The “Vee” model is a widely recognized Systems Engineering process. The “Vee” model, shown in [Figure 2](#), was developed to address issues concerning the decomposition, definition, integration, and verification of a

system.³ Mooz and Forsberg describe what they call “the technical aspect of the project cycle” by the “Vee” process model.⁴

The model begins with the definition of system requirements on the upper left as the problem is decomposed and defined. This phase of the model is meant to resolve the system architecture, preparing the details that will be essential to system design. First, the system requirements are defined primarily based on stakeholder needs and the functions for which the system will be designed to perform. These requirements are meant to clarify the functions to be performed by the system. The functions are allocated to subsystems. The system is comprised of subsystems. The systems engineer matches functional requirements to subsystems, allowing for specific components to be chosen that will perform the required functions at the component level. Once this level of design is completed, the system design is then “built upwards” to begin to produce a user-validated system on the upper right of the Vee Model. Verification of components and systems with respect to the originating requirements occur through each level of the integration and verification sequence. After verification and validation, the system becomes fully operational.

³ Mooz , Hal and Kevin Forsberg. The Dual Vee – Illuminating the Management of Complexity. Paper submitted to the Sixteenth Annual International Symposium of the International Council

⁴ Blanchard, Benjamin S. and Wolter, J Fabrycky, Systems Engineering and Analysis, 4th Edition, Pearson Prentice Hall, Upper Saddle River, NJ, 2006.

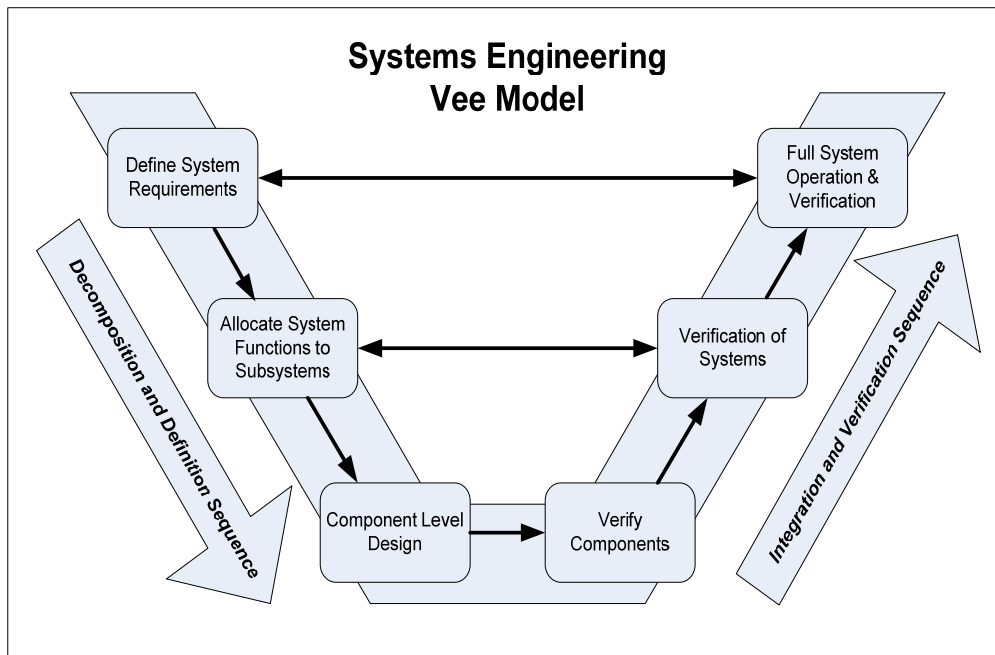

Figure 2. Systems Engineering “Vee” Model⁵

The “Vee” Model provided a basis to begin developing our process model of the project. It became apparent early on that the “Vee” Model was not the logical choice for our process due to many functions that would not be considered or analyzed. One example is the last phase when the system is tested and validated. Our project focused on analysis of a future concept, and specific subsystems were not designed or tested.

Additionally, the “Vee” Model includes many processes that are not required for this project, several aspects of this model which are not applicable, and multiple tasks are not detailed to the level needed in order to develop a system architectural concept.

1.5.3. SEA-16 Project Tailored Process

SEA-16 developed a tailored process based on a modified “Vee” Model, shown in [Figure 3](#). Our modified model is composed of four phases. These

⁵ Ibid.

phases are: Project Definition, Systems Analysis, Preliminary Design, and System Design for Utility.

This model provided the framework for the development of the architecture concepts and allowed the team to decompose and refine the project as work progressed from “Project Definition” through “System Design for Utility”.

Work in each phase of the project builds upon itself as the basis for each follow-on phase. Additionally, a feedback loop provides the capability to review work completed in previous phases. This feedback loop recognizes the need for multiple iterations required for development.

1.5.3.1. Project Definition Phase

In the Project Definition phase, the problem was decomposed through several tasks. A formal vision statement was developed to provide direction for the study. This vision statement is contained in [Section 2.1](#). A stakeholder analysis was conducted which identified and analyzed each stakeholder’s functional role and capability mission area. The functional requirements are the role they play in relation to the system and the capability requirements relate to mission areas of the system. The results of the stakeholder analysis are detailed further in [Section 2.10](#), and shown in [Table 4](#). The results of the needs analysis are contained in Section 2.3. During this phase, the team also completed a Consequence Analysis to identify trends and issues pertaining to the implementation of the architecture. These results are contained in Sections 2.4 and 2.5. Command and Control, Technological, Geopolitical, and Military factors for design were listed to guide the context of the project.

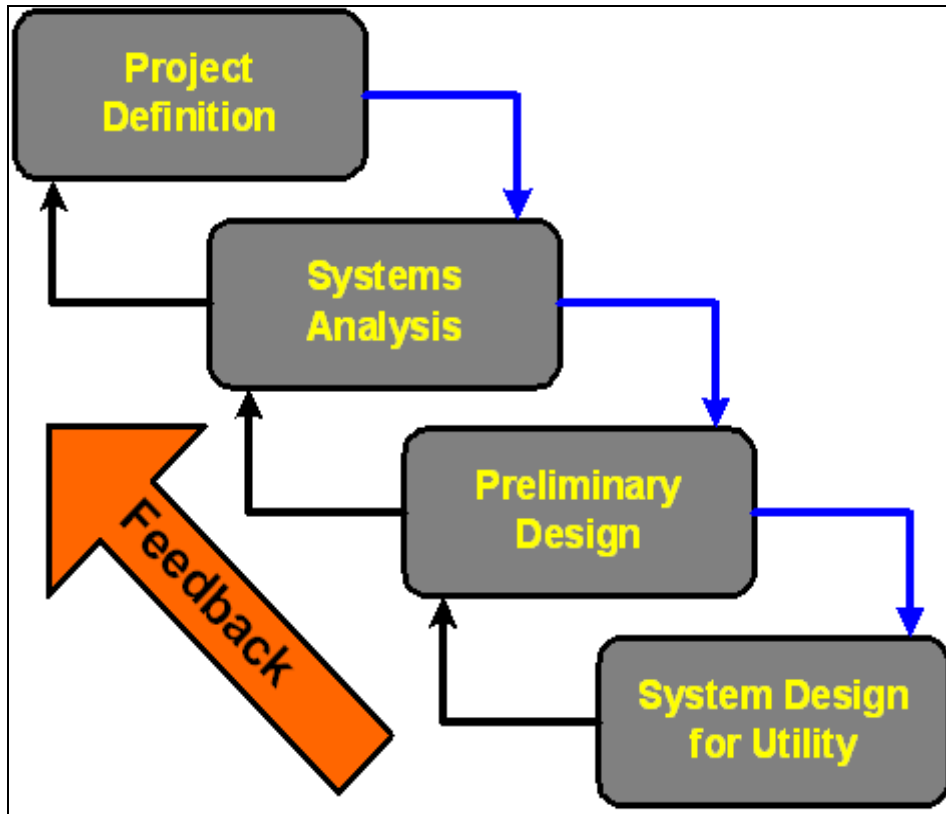

Figure 3. SEA-16 Modified “Vee” Model

1.5.3.2. Systems Analysis Phase

The Systems Analysis phase consisted of trade studies in five categories. The group reviewed UMS and their functionality in current operations, to provide a context in which to project their future roles. The study of UMS included an engineering assessment of trends and technological advancements. Human effects to a system, specifically the implications of a man in the loop and the selection of a level of autonomy was examined.

1.5.3.3. Preliminary Design Phase

The Preliminary design phase of development built upon the concepts from the Project Definition and Systems Analysis phases to produce the system concept of operations and the architecture products which define the system.

1.5.3.4. Systems Design for Utility Phase

The System Design for Utility phase applied the system concepts to model system application. In this project, the model demonstrates one of the countless possible applications of the system.

1.6. TEAM ORGANIZATION, ROLES, RESPONSIBILITY

1.6.1. Team Composition

Each team member was assigned to specific Integrated Project Team (IPT), which are standing groups ready to receive project tasking, as illustrated in [Section 1.6.2](#), and to a specialty area Track Team, as illustrated in [Section 1.6.3](#). Team members in each specific discipline area were selected for an IPT to ensure cross-disciplinary inputs and interaction. This organizational concept promoted efficient exchanges of information, reduced redundant efforts, and promoted lively discussions. Detailed work within a specific discipline area was completed by the Track Teams. Work within the Track Teams focused on the subject matter of their curriculum.

The SEA-16 organization is shown in [Table 1](#). LT Thompson was selected as the Project Manager and had overall responsibility for successful completion. MAJ Ang Teo Hong (Republic of Singaporean Air Force) was elected Assistant Project Manager.

During the fall quarter 2010, the students in Monterey began to work with the Singaporean-based students. Following the Systems Engineering process lecture, which was conducted by Professor Gary Langford in October 2009 with students from NPS and the National University of Singapore (NUS) though a Video Teleconference (VTC), the Temasek Defence Systems Institute (TDSI) students set up the Singapore SEA-16 Organizing Committee (SSOC) to spearhead all initial project discussions and clarifications between the two geographically separated groups of students. The members of the SSOC were MAJ Ang Teo Hong, MAJ Lim Han Wei, MAJ Gabriel Tham Chi Mun, Yinon

Costica, LT Dustin Cunningham, Mr. Wong Ka-Yoon and Mr. Delvin Gho Seng Wee.

Leadership	Project Manager	LT Bradley Thompson			
	Asst. Project Manager	MAJ Ang Teo Hong			
		IPT1	IPT2	IPT3	IPT4
Tracks	Systems Engineering	LT Johnson	LT Nilsson	LT Moran	CDR Quincy
	Simulation Team	MAJ Ting Chi Yon	Delvin Gho	Wong Ka-Yoon	Yinon Costica
		Tommy Chia	LT Adam Matthews	Jason Wong	
	Comms, Networks, and Sensors	MAJ Lim Han Wei	ME5 Ng Wei Gee	Tan Yean Wee	ME5 Tong Kee Leong
		Lu Chin Leong	Chia Boon Chye	Henry Seet	ME5 Lo Chee Hun
					ME5 Gabriel Tham
	Information Assurance	Ho Liang Yoong	Raymond Quah	Quek Chee Luan	Ang Kah Kin
			Toh Boon Pin	Ng Yeow Cheng	
Weapons	CPT Tan Wei Chieh	ME4 Tan Chin Wah John	LT Dion G Fontenot	LT Omari D Buckley	
	LT Dustin Cunningham		CPT Lim Wei Han Eugene		

TABLE 1. SEA-16 MATRIX ORGANIZATIONCHART.

1.6.2. Integrated Project Teams

Four members of SEA-16 were assigned to lead an IPT. LT Johnson led IPT 1, LT Nilsson led IPT 2, LT Moran led IPT 3, and CDR Quincy led IPT 4.

1.6.2.1. *Integrated Project Team 1*

IPT1 focused on current mission capabilities and gaps for the Explosive Ordnance Disposal (EOD) mission area of NECC. This was done with a question and answer session with actual EOD personnel. From the information gathered an analysis of potential future uses of UMS throughout the EOD spectrum was performed. From that analysis three scenarios were developed to explain the mission, gaps and possible solutions for UMS in EOD. These mission gaps were then presented to the Steering Committee in order to explore possible follow on studies and agree upon the ultimate area of focus.

1.6.2.2. Integrated Project Team 2

IPT2 initially conducted research regarding NECC's Riverine forces. The team researched the chain of command, manning, equipment, and mission requirements. The team then analyzed the operating environment to identify threats, environmental and terrain aspects, and common scenarios faced by Riverine operators. The team identified potential uses of unmanned vehicles in order to enhance operational effectiveness.

IPT2's next major focus area was the development of the functional architecture. The team developed a functional decomposition, functional flow block diagrams, input/output diagrams, and performance characteristics for each function.

1.6.2.3. Integrated Project Team 3

IPT3 completed work in several key areas. First, the group examined the missions and roles of the Maritime Expeditionary Security Force (MESF) component of NECC. These missions were detailed in a hierarchical fashion according to functional breakdowns. The highest-level function was "Conduct Force Protection". As the project evolved, the team focused on the implications of having a man-in-the-loop for a system. This trade study involved identified human and machine roles, and considered the information in terms of the command and control paradigm.

1.6.2.4. Integrated Project Team 4

Initially, IPT4 developed a plan for the project. The team conducted a tradeoff of three Systems Engineering process models (i.e., waterfall, spiral, Vee), to compare the time and documentation requirements. This analysis led to the Systems Engineering Waterfall Process developed by the Systems Engineering team. IPT4 researched and selected a definition for autonomy and autonomous. IPT4 also selected the Autonomy Levels for

Unmanned Systems (ALFUS) model that would be used by the teams. This evaluation is further described in [Section 3.3](#).

1.6.3. Track Teams

As with the IPTs, members of the team were also assigned to a Track Team. The purpose of the Track Teams was to focus the knowledge of the group on the specialties associated with their curriculum. There were five Track Teams involved in the project; the Systems Engineering Track Team led by CDR Keith Quincy, the Simulations Track Team led by Wong Ka-Yoon, the Communications, Network, and Sensors Track Team lead by MAJ Tong Kee Leong, the IA Track Team lead by Toh Boon Pin, and the Weapons Track Team lead by LTJG Dustin Cunningham.

1.6.3.1. Systems Engineering Track Team

The Systems Engineering (SE) Track Team was responsible for the overall coordination of the project. This team provided the overall direction for the project by developing the Waterfall model which was used to manage the processes for the project. They provided the knowledge and guidance to scope and iterate the project. Team members attended conferences, lectures, and corresponded with stakeholders. Due to scoping, not all aspects of the concept would be examined, and these decisions were determined by the SE Track Team. A listing of items that would require future research and study to aid in realizing the system concept proposed is included in [Section 6.3](#) of this report.

1.6.3.2. Simulation Track Team

The Simulations Track, comprised of students from the Operations Research (OR) and Modeling, Virtual Environments, and Simulation Institute (MOVES) curriculum provided perspective on the problem formulation and scenario selection by comparing current operational practice with proposed future operations. The team members played a role in defining the scenario for demonstration of the C2 architecture proposed in this report. An analytical-

stochastic model, augmented with discrete event simulation, was built to illustrate the notional force size and force effectiveness of a fleet of unmanned aerial systems in detecting an incoming ASCM. A sensitivity analysis was conducted. These results, further detailed in [Section 5.7.](#), showed that for this concept between 21 and 35 UAVs would be required to extend the ISR and subsequent Force Protection ring around a HVU. Through both the process and results of the modeling and simulation, greater clarity was achieved concerning the future C2 architecture, component systems and Concept of Operations (CONOPS).

1.6.3.3. Communications, Networks, and Sensors Track Team

The Communications, Sensors, and Networks Track Team provided the expertise in communications and surveillance to the various in IPT during the initial stages of the project. After the shift in focus for the project, the team provided critical support the Command and Control Architecture Task Force (C2ATF) and Operations Research and MOVES Task Force (OMTF). Specifically, the sensors group provided the geopolitical trends and operational imperatives that shaped the way the sensors technology may evolve. The team also explored and highlighted possible technologies that supported the Command and Control (C2) architecture. The team also focused on the C2 architecture development. Additionally, the sensors team contributed to the development, simulation and validation of the C2 architecture by evaluating and proposing an appropriate sensor detection range for a sea-skimming missile operating at supersonic speed. An evaluation report was submitted for both C2ATF and OMTF.

The Communications and Network (CN) systems facilitate dissemination of information over vast Area of Operation (AO) in a timely and organized manner. These mechanisms would form the backbone for Command, Control, Communications, Computers and Intelligence (C4I) architecture and enable joint Command, Control, Communications, Computers and Intelligence

Surveillance and Reconnaissance (C4ISR) operations. In this integrated project, the CN team provided expertise to the C2ATF in developing the Command and Control architecture for air, land and sea operational theatre, established the generic type of traffic profile between sensors, command and shooters in the OODA loop. The CN team also supported OMTF in analyzing communications link budget and assessed the viability of the communications network in the proposed scenario.

1.6.3.4. Information Assurance Track Team

The Information Assurance (IA) group was involved in the design of Command & Control (C2) architecture capable of supporting different type of operations involving manned and unmanned vehicles in 2030. The team members worked closely with other groups to ensure a coherent C2 architecture that is capable of supporting the various initiatives. The IA group also identified ways to safeguard information assets by examining problems from an information assurance perspective. The confidentiality; integrity and timely availability of information often play an important part in the success of military operations. This included

assessment of security for individual components that formed the C2 architecture to ensure information flow among these components. Appropriate security measures (such as access control, authentication protocol, implementation of cryptography) were proposed taking into consideration the constraints imposed by the operational environment. Potential risks were identified to help support proper risk management decision making.

1.6.3.5. Weapons Track Team

The Weapons Systems Track provided the technical view-point for the SEA-16 design project by implementing the study of Mechanical and Astronautical Engineering. The students in this track provided identification of technical problems and helped solve platform specific issues in terms of future performances and data extrapolation. Weapons Systems students researched and

analyzed current unmanned platforms to understand what these systems will be capable of over the next two decades. Additionally, during focused trade studies of propulsion-based technology, the knowledge of design, testing, maintenance, failure prediction, and operation requirements for the technologically advanced military equipment of the future allowed for platform performance predictions that were integrated into the models and simulations. The Weapons Systems Track also worked in cooperation with the CNS Track team on areas that involved the application of sensor-shooter OODA loops. The ability to bridge the gap between engineering technology and military operations, in addition to presenting mathematically and technically diverse material, made the Weapons Systems Track an integral part of the SEA-16 design project.

THIS PAGE INTENTIONALLY LEFT BLANK

2.0. CONCEPT OF OPERATIONS (CONOPS)

2.1. PROJECT DESCRIPTION

The military domain of 2030 was viewed as being both local and global, which meant that information gathered at a specific location must be able to be disseminated to enrich the situational awareness of forces regardless of where operational nodes are in relation to the information gatherers. The C2 architecture needs to be flexible to allow new technology to be integrated into the C2 framework. The overarching C2 architecture will provide the structure to drive the integration of technological advances into the existing system. Without an overarching C2 structure, the US and coalition forces may not be able to exploit technological advances as well as it could with an adequate architecture.

2.2. BACKGROUND

There is no overarching command and control architecture that integrates manned and unmanned vehicles within the battlespace. Some problems with the current system include:

- Direct communication occurs only directly between specific users and vehicles, or directly between users (Shown in [Figure 4](#))
- Situational awareness is not maximized due to communications and data sharing limitations
- It is difficult for users to provide cross mission utilization of platform
- Fusion of information occurs by the collaboration of users directly with each other
- Overall, forces are a mix of individual systems and micro-level systems of systems

There exists a need to fulfill an enhanced Command and Control Capability that:

- Provides a Common Battlespace picture to all users
- Includes a Common interface needed to enable system integration

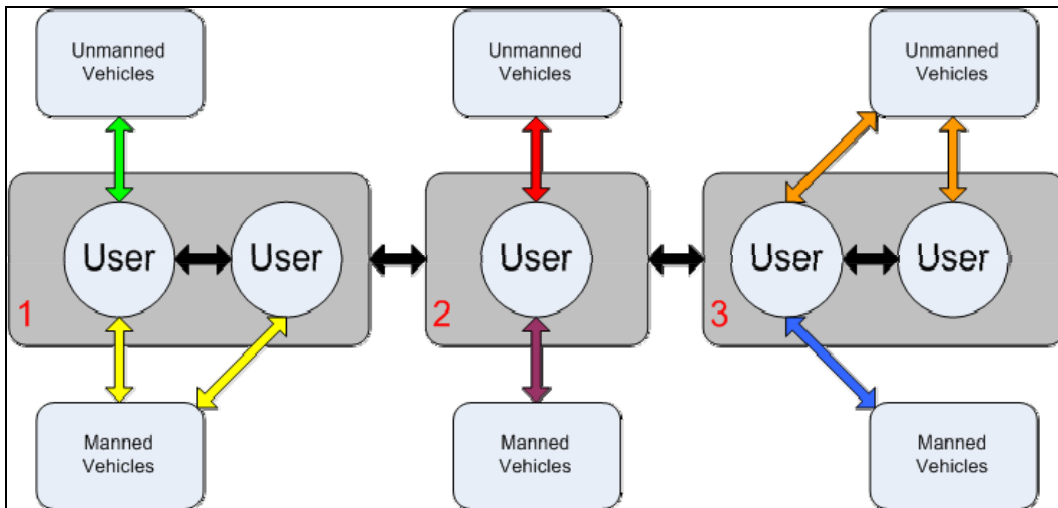

Figure 4. Characterization of Current Command and Control Relationships

2.3. TRENDS AND ASSUMPTIONS

2.3.1. Technology Trends

SEA-16 conducted a trade-study to determine trends in technology that may have key impacts on the C2 architecture required for future battlespace coordination and tasking.

Common Communication Architecture In recent years the U.S. Navy has battled a costly maintenance, logistics and support problem. Much of the trouble lies with the fact that many of the C4I systems aboard Navy ships requires a separate network infrastructure with a unique set of connections maintenance and repair experts to keep the system running. Experts believe that migrating to a single Common Communication Architecture reduce the expense of networks while the abilities continue to expand.⁶

Composable Systems Composable systems that allow different systems to collaborate and enhance multiple capabilities will be prevalent in the future.

⁶ Hoover, Nicholas J., "Army CIO Advances Consolidation Effort," Information Week, December 29, 2009
<http://www.informationweek.com/news/government/leadership/showArticle.jhtml?articleID=222002965>

With the increase in functionalities per product, unmanned vehicles and soldiers can achieve higher levels of autonomy.⁷

Nanotechnology Nanotechnology is the study of the controlling matter on an atomic and molecular scale. This technology generally deals with materials of the size 100 nanometers or smaller.

Nanotechnology is very diverse, ranging from extensions of conventional device physics to completely new approaches based upon molecular self-assembly, from developing new materials with dimensions on the nano-scale to investigating whether it can directly control matter on the atomic scale.

The implications of nanotechnology ranges from medical and environmental, to fields such as engineering, biology, chemistry, computing, materials science and communications. Specific to implications to military C2 functions, Potentially, nanotechnology is a key driver to increase memory space and processing power, miniaturization of electronic devices and improving energy efficiency.⁸

Improvement in Energy Efficiency Synthetic Fuels, lithium ion batteries and fuel cells are examples of improvement in energy density over the recent years. This increase in density will no doubt directly affect the endurance of Unmanned Vehicles. With a higher endurance, operational time will increase and thereby giving rise to an increased radius of operation.

Automation Assuming technology advancement continue to make moderate gains, the ability for machines to conduct more and more routine operations will allow for the reduction of man power. An example of this can be found in the Navy's new Littoral Combat Ship (LCS).⁹ Increases in automation allow for machines to do more of the work that humans currently perform, and reduce operator interaction.

⁷ Hoffman, Michael, "Technology by 2030: Looking to Change Game," Air Force Times, January 20, 2010, http://www.airforcetimes.com/news/2010/01/airforce_scientist_011810w/

⁸ American Elements "Nanotechnology Information Center," <http://www.americanelements.com/nanotech.htm>, accessed May 15, 2010.

⁹ Access my Library "General Dynamics Robotic Systems Awarded Navy LCS Automated Contract". July 21, 2008, http://www.accessmylibrary.com/coms2/summary_0286-34837787_ITM

Micro Air Vehicle Micro Air Vehicle (MAV) refers to a class of unmanned air vehicle (UAV) that is restricted by size. According to the definition employed in Defense Advanced Research Projects Agency's (DARPA) program, the limits on MAVs are those crafts that are less than 15 cm (about 6 inches) in length, width or height. MAVs are at least an order of magnitude smaller than any conventional UAVs currently operational use.¹⁰

Taking inspiration from flying insects and birds to achieve unprecedented flight capabilities has fast become a new trend in the MAV community. Other than unsteady aerodynamics of using flapping wings, aspect that further inspired the engineers includes; distributed sensing and acting, sensor fusion and information processing.

MAVs are envisioned to be an affordable system that will be locally owned and operated at the platoon level or below. With the reduction of latency and size inherent in current assets, MAVs will be capable of operating in constrained environments like urban canyons and ultimately the interior of buildings. Consequently, individual soldiers will receive on-demand information about the surroundings, resulting in unprecedented situational awareness, greater effectiveness and fewer casualties. MAVs are predicted to undergo a rapid evolution in military usefulness in the near future.¹¹

¹⁰ McMichael, James M., "Micro Air Vehicles – Towards A New Dimension in Flight," Federation of American Scientists, August 7, 1997, http://www.fas.org/irp/program/collect/docs/mav_auvsi.htm

¹¹ Hanlon, Mike, "UAVs Get Smaller: The Micro Air Vehicle Nears Readiness," Giz Magazine, September 25, 2005, <http://www.gizmag.com/go/4779/>

2.3.2. Assumptions

Technology assumptions and military assumptions were made to determine possible implications for 2030 operations. Six key assumptions in the categories of technology and military were identified. These results can be found in [Table 2](#) and [Table 3](#).

Technological Assumptions There will be reduced proliferation of proprietary technology, making system interfaces highly compatible and reducing the costs required to modify a product for compatibility. Systems will have increased functionality, with multiple mission capabilities. To complete multiple missions at once, systems will require high levels of autonomy because humans will be unable to maintain the required operational tempo. As unmanned systems become more productive, human participation could decrease. This will increase the general reliance on unmanned technology, requiring the implementation of a collaborative C2 architecture to manage these assets. Energy efficiency will increase, enhancing mission capability by increasing on-station time for all vehicles. Lastly, the possible lower costs of entry into this technology will make it available to many state and non-state actors throughout the world. This will make maintaining cutting edge technology critical to counter these continually evolving threats.

Assumption	Implication
Moving from proprietary architecture to a common architecture	High R&D costs to mature common UMS C2 architecture
Increased individual system functionality and mission capabilities	Higher level of autonomy for unmanned vehicles
Unmanned systems with increased autonomy will become highly productive	Increased productivity of highly autonomous systems will reduce necessity for human participation
Increased reliance on unmanned technology	Collaborative integrated C2 architecture will be necessary to manage large quantities of vehicles
Increased use of efficient energy sources	Increased on-station time for unmanned vehicles
Smaller technology gap on a global scale	Critical to investment in advanced technology

TABLE 2. TECHNOLOGY ASSUMPTIONS.

Military Assumptions

The first assumption in 2030 is U.S. forces will have a near-peer competitor, necessitating the use of UMS as force multipliers. In addition to our own forces, coalition forces will be needed to counter common threats to maintain global security. To enable their participation, common interfaces will be needed to ensure full collaboration and the maximum availability of assets. The increased military reliance on technology will drive the need for a technologically savvy force. The desire to protect human life continues to increase, and unmanned vehicles will continue to provide opportunities to reduce human presence in dangerous environments. Our forces will need to be able to react quickly to conflicts around the world, possibly requiring more expeditionary forces to be forward based. Finally, all forces will be fighting for the use of the RF spectrum. This will necessitate maintaining spectrum dominance and optimization of available space.

Assumption	Implication
U.S. forces will have a near-peer competitor	Affects all current planning norms and assumptions, including need for UMS as a force multiplier
Greater use of coalition forces	Increased need for common interfaces
Increase in military reliance on technology	Higher need for technologically trained force
Protection of military personnel will be paramount	Removal of humans from dangerous environments will necessitate increased unmanned presence.
Reliance on mobile global force	Expeditionary “ad-hoc” forward basing becomes more common
Contention of finite RF spectrum usage between all forces (Friends and Foes)	Need for spectrum dominance and optimization strategy

TABLE 3. MILITARY ASSUMPTIONS.

2.4. OVERVIEW OF THE ENVISIONED SYSTEM

2.4.1. Overview

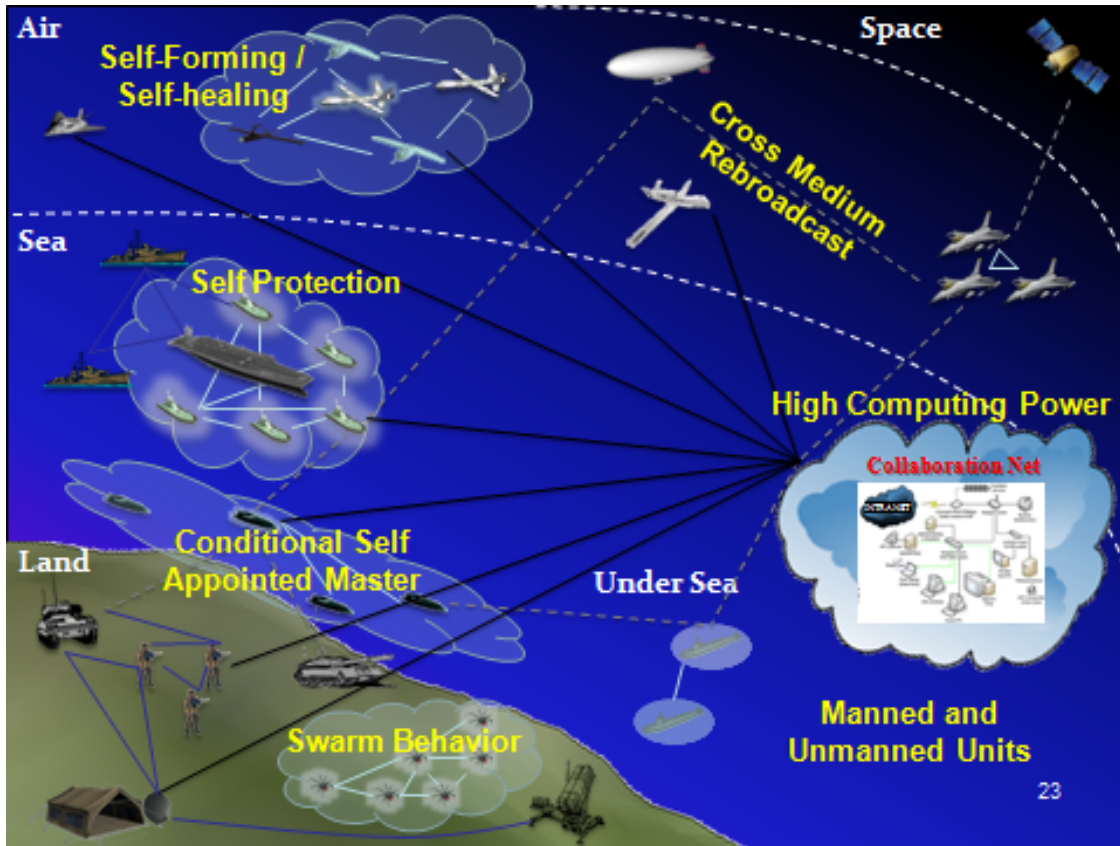

Figure 5. Overview of the 2030 Joint Command and Control Architecture Concept

The 2030 Joint Command and Control Architecture, as shown in [Figure 5](#), will enable a robust collaboration of information across all warfare domains to disseminate information in order to enhance situational awareness within the battlespace. This allowed any node within the system to exploit the collective knowledge to execute its mission. Advanced collaboration will be enabled by advances in information sharing, specifically a Collaboration Network with High Computing Power, compatible communications standards, and an Advanced Cross Medium Rebroadcast capability. An open architecture design allowed for coalition forces or government agencies to interface with the system, and fully integrate with U.S. forces.

2.4.2. System Scope

The system will be composed of all nodes and their interfaces that operate in the battlespace and are under the authority and responsibility of U.S. military forces, or operating in cooperation with those forces. Each of these acts as either an input, output, or both with respect to the system.

Nodes include, but are not limited to:

- Manned Vehicles
- Unmanned Vehicles
- Personnel
- Broadcasting and Rebroadcasting Stations
- Satellites
- Computer Networks
- Command Centers

2.5. GLOSSARY

See [Section 7.0](#). for a complete listing of all abbreviations, acronyms, and definitions used in the compilation of this project.

2.6. DOCUMENT REFERENCES

See [Section 8.0](#). for a listing of sources that were referenced multiple times. Footnotes are used throughout the paper to properly document sources.

2.7. GOALS, OBJECTIVES AND RATIONALE FOR THE NEW SYSTEM

2.7.1. Goals and Objectives of the New Capability

The goals and objectives of the system are summarized in [Figure 6](#).

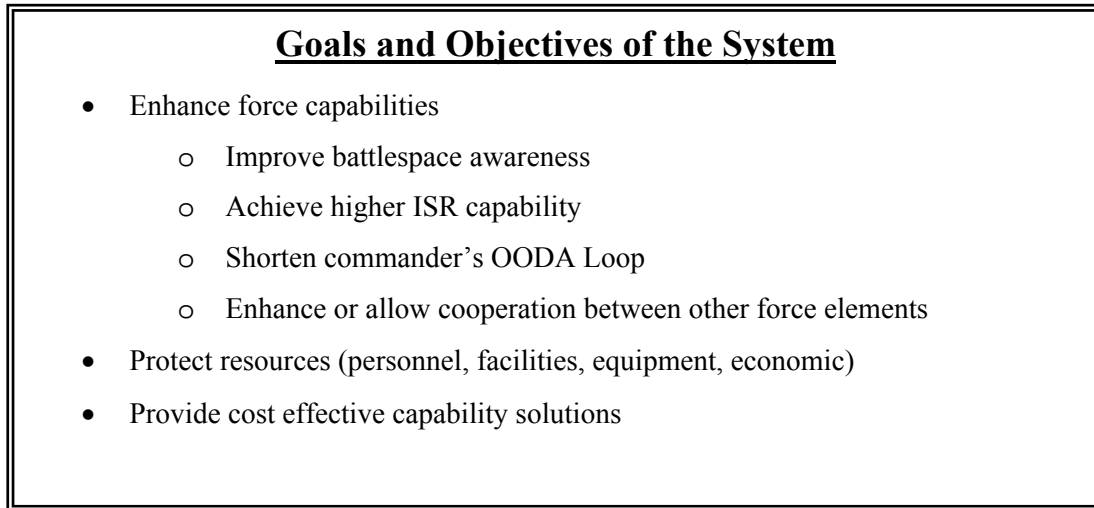

Figure 6. Goals and Objectives of the System

Enhance Force Capabilities. This architecture concept must enhance force capabilities on higher command levels, by providing commanders and planners with improved awareness of the entire battlespace through improvements in ISR. By utilizing more timely and complete information, commanders will have the opportunity to have a shortened OODA Loop. Additionally, an open architecture design ensured coalition forces and government agencies can operate with forces and increase overall capabilities.

Protect Resources. The system must protect several categories of critical national resources. These categories include personnel, facilities, and equipment.

Generally, UMS are used for missions that are considered “dull, dirty, or dangerous,” with respect to humans.¹² The value of military personnel continues to grow, as reducing the risk to human life has become a critical consideration from the strategic to the tactical level. Personnel costs continue to rise, and individual training

¹² Canning, John S. A Definitive Work on Factors Impacting the Arming of Unmanned Vehicles. Naval Surface Warfare Center, Dahlgren, VA. May 2005. p. 12, <http://www.dtic.mil/cgi-bin/GetTRDoc?Location=U2&doc=GetTRDoc.pdf&AD=ADA436214>

requirements typically increase as a more technically capable force is required. Military planners desire to increase functional capability while removing human operators from dangerous positions.

Greater battlespace awareness better prepares forces to protect critical infrastructure. Facilities and equipment can have increased threat warning time, and commanders can properly match force capabilities to protect priorities.

Provide cost effective capability solutions. “The determining driver will likely be the cost of providing a particular warfighting capability.”¹³ Maximizing utility with budgetary limitations will continue to be a challenge for the Department of Defense (DoD). Assets must be designed to be highly effective while observing the cost restraints that exist. The implementation of UMS in the battlespace will change costs of personnel tremendously. As highly trained warfighters are replaced by machines, highly trained technical personnel will be required to maintain and operate the systems.

2.7.2. Rationale for the New Capability

There exists a deficiency in the current C2 architecture that is exposed by numerous emerging factors, including: high-speed threats, large numbers of nodes without an overarching architecture, heavier reliance on technology in battlespace, information overload, and reactive implementation of UMS management for systems interoperability.

2.8. HIGH-LEVEL FUNCTIONAL REQUIREMENTS

2.8.1. High Level Features

The following high-level functional requirements, illustrated in the [Figure 5](#) were derived from operational scenarios.

- Self-Protection – Manned and unmanned systems, through collaboration, will increase the level of protection for HVU.

¹³ Canning, John S. A Definitive Work on Factors Impacting the Arming of Unmanned Vehicles. Naval Surface Warfare Center, Dahlgren, VA. May 2005. p. 12, <http://www.dtic.mil/cgi-bin/GetTRDoc?Location=U2&doc=GetTRDoc.pdf&AD=ADA436214>.

- Cross-medium Rebroadcast – The ability to transmit data across medium boundaries, such as from aircraft to submerged vehicles. This feature will be essential to the overall functioning of the architecture as it enables data to be transmitted across available communication assets.
- Communications Relay - The network relies on each platform having the capability to receive and then retransmit data and information to other nodes within the battlespace.
- Self-Appointed Master UMS – Any unmanned vehicle can assume tactical control of a large number of Unmanned Vehicles, and facilitate command and control capabilities of the controller.
- Self-forming/ Self-Healing Network – Failure or loss of a system does not preclude operation as the remaining UMS have the ability to replace the Self-Appointed Master UMS.
- Swarm Behavior – Control methodology capable of utilizing swarm tactics for UMS vehicles across all domains. The unmanned vehicles must have sufficient autonomy to recognize and adapt to its local environment, only passing to the network required data, so that the network does not become overloaded with information.
- Sensor/Platform Diversity - Sensors must enable the exploitation of all necessary observables such as acoustic waves and electromagnetic waves. The sensors must cover the range of electromagnetic waves including observable, infrared, and radio frequencies.
- Different levels of Autonomy/Artificial Intelligence - UMS operating in the battlespace may operate at the required level of autonomy. High levels of autonomy will be required to conduct swarm tactics and operations requiring efficient use of a communications network. Lower levels of autonomy may be required for particular missions such as an explosive ordinance technician disabling an improvised explosive device.

2.8.2. Additional Features

- Renewable & Sustainable Energy - The efficient use of fuel resources will be an important element of future operational vehicles. Wherever possible, renewable sources of fuel, such as bio fuels, will need to be utilized.
- High Computing Power & Storage Capacity - The architecture relies heavily on the ability to collaborate data. In order to maintain such large amounts of data and have that data available as useable information, the computing and storage capacity of the network must be sufficient.

2.9. IMPACT CONSIDERATIONS

2.9.1. Operational and Organizational Impacts

- Cultural resistance to changing what is typically considered uniquely human professions could cause some challenges to the implementation of this concept.

2.9.2. Consequence Analysis

Risk analysis is a basic element of any program and should be considered throughout all phases of the lifecycle. While risk is a very detailed evaluation of possible future issues, for this project a higher level consequence analysis was conducted. In general two main categories were addressd that are associated with a future force structure that encompasses manned and unmanned systems working together. The first category encompasses what happens if thre is failure to act now and research the fielding of such a system; and the second category deals with what could potentially happen if such a system was developed and fielded.

2.9.2.1. *Failure to Act*

- Due to the lack of efficient transfer of raw data there may exist a problem of information overload and therefore a decrease in situational awareness
- Continuing with a reactive implementation of UMS management rather than proactive achievement of a more effective structure
- Technology will not mature to enable integration and interoperability of manned and unmanned systems
- Failing to pursue this concept may cause the United States to fall behind its rivals and partners in the command and control of UMS

2.9.2.2. *Impact of Implementation*

- With a heavier reliance on technology there will become a higher demand for data analysis and Information Technology personnel
- With a heavier reliance on technology there will become a requirement for a technically savvy force
- A possible restructuring of DoD may be required in order to meet the challenges of an integrated manned and unmanned force
- Future conflicts will require the United States to work more with allies, resulting in a higher reliance on coalition forces
- Higher reliance on coalition forces will require parallel technology and doctrinal development for all forces
- In order for parallel technology development to succeed there will be a need for international common standards for interoperability

2.10. STAKEHOLDER ANALYSIS

There are two main categories of stakeholders for this project: interested and affected organizations. Interested Organizations are those groups that have expressed actual interest or provided input to the project. Affected organizations are those groups that have as of yet expressed interest in the project but would be majorly affected by the outcome of this project.

2.10.1. Interested Organizations

Included in the Interested Organizations are the project sponsors. This project's primary sponsors were the Director of Warfare Integration (N8F) and Navy Expeditionary Combat Command (NECC). Any project that explores UMS will have a large number of stakeholders, but one that examines developing a joint unmanned vehicle architecture casts a large net, and includes areas of study which can attract interest from a variety of organizations.

A stakeholder analysis which formally lists these interested organizations is shown in [Table 4](#).

2.10.2. Affected Organizations

Affected Organizations encompass a broad range of agencies, from those either currently using or developing UMS to those that have capability requirements that would benefit from the use of UMS. The organizations were separated into eight groups: Industry/Government Organizations, Military, Government Agencies, Other Nations, International Organizations, Other Organizations, Enemy Threats, and Users. A stakeholder analysis which formally lists potentially affected organizations is shown in [Table 4](#).

2.10.3. Stakeholder Functions

The stakeholder analysis, as shown in [Table 4](#), differentiates the activities into four areas, where stakeholders could have interaction. These four areas are Acquisition, Management, Logistics, and Operator.

- The Acquisition process shows those organizations that would be interested in the development, procurement, production, and testing of UMS. A Joint Architecture would reduce some redundant system development and would also promote a system of systems design concept, reducing the cost associated with integrating systems after development or deployment. These organizations range from military acquisition commands to government contractors who produce systems.
- The Management process describes those organizations that are responsible for the administration and coordination of UMS usage. A Joint Architecture would reduce the complexity of managing disjoint systems; directly increasing productivity at all levels in support of component commanders and user level commands.
- The Logistics process shows those organizations that are responsible for the maintenance and transportation of manned and unmanned systems. A Joint Architecture would simplify the logistics tail, by implementing standard procedures, repair parts, and interfaces. An example includes the Program Executive Offices responsible for the execution of specific UMS programs.
- The Operator process applies to those organizations responsible for either the user level usage of UMS or whoever is responsible to the user for support. The benefit of a Joint Architecture for the user is increased access to information in the field. Examples of the Operator function are specific user commands and those command organizations providing personnel or equipment to the component commander.

2.10.4. Stakeholder Capabilities

Through the stakeholder analysis, nine capabilities were identified, and stakeholder activity was evaluated for each of these capabilities, as shown in [Table 4](#). The capabilities determined to be most important are Communications (COMMS); Intelligence, Surveillance and Reconnaissance (ISR); Strike, Force Protection, Electronic Warfare (EW), Maritime Warfare, Land Warfare, Transport, and Air Warfare.

- The Communications capability is for those stakeholders who are responsible for transmission, reception, or rebroadcasting of voice or data communications.
- The ISR capability is for those stakeholders who provide battlespace awareness functions.
- The Strike capability is for those stakeholders who provide precision bombing and attack functions.
- The Force Protection capability is for those stakeholders who provide defensive functions within the battlespace.
- The EW capability is for those stakeholders that provide support to the battlespace via the electromagnetic spectrum (electromagnetic jamming and attack, Electromagnetic Support (ESM), and anti-radiation weapons).
- The Maritime Warfare capability is for those stakeholders that provide Surface Warfare support to the battlespace.
- The Land Warfare capability is for those stakeholders that provide land combat resources to the battlespace.
- The Transportation capability is for those stakeholders that provide the timely movement of complete systems or maintenance parts.
- The Air Warfare capability is for those stakeholders that provide aircraft of anti-aircraft support to the battlespace.

2.10.5. Analysis of Stakeholder Needs

The stakeholders were analyzed in terms of level of expected interest in the project, assessment of project impact towards their requirements, process activity, and capabilities. Stakeholder interest and assessment of impact is generally categorized in qualitative levels: Low (L), Medium (M), and High (H), with some stakeholders identified as lying between these levels.

	Stakeholder Interest(s) in the Project	Assessment of Impact	FUNCTIONS				CAPABILITIES							
			Acquisition	Management	Logistics	Operator	COMMS	ISR	Strike	Force Protection	EW	Maritime Warfare	Land Warfare	Transport
Interested Organizations														
Navy Expeditionary Combat Command	H	H		X		X	X	X		X	X	X	X	X
Naval Undersea Warfare Center Newport	M	M		X	X	X	X	X		X	X	X		X
Unmanned Surface Vehicles (PMS-403)	M	H	X	X	X		X	X		X	X	X		X
Naval Oceanography MIW Center	M	M		X		X	X	X		X		X		
Naval Surface Warfare Center	M	M	X	X	X	X	X	X	X	X	X	X		X
Littoral and Mine Warfare (PMS-420)	M	H	X	X	X		X	X	X	X	X	X		X
Office of Naval Research	L	L		X			X	X	X	X	X	X	X	X
Jet Propulsion Laboratory	L	M		X			X		X	X	X	X		X
OPNAV N-8F	L	M	X	X										
OPNAV N-857	M	M	X	X	X		X	X	X	X	X	X		X
OPNAV N2/N6	L	M	X	X			X	X	X	X	X	X		X
Naval Postgraduate School	M	M		X			X	X	X	X	X	X	X	X
UIV Advanced Development	L	H		X			X	X	X	X	X	X		
PEO LMW (PMS-495)	M	M	X	X	X		X	X		X	X	X		
PEO (U&W), NAVAIR	L	M	X	X	X		X	X	X	X	X	X	X	X
Industry/ Government Contractors														
Lockheed Martin	M	H	X	X	X	X	X	X	X	X	X	X	X	X
iRobot Maritime	M	M	X	X	X	X	X	X	X	X	X	X	X	X
Hydroid	L	M	X	X	X	X	X	X	X	X	X	X	X	X
Orca Maritime	L	L	X	X	X	X	X	X	X	X	X	X	X	X
Military														
Department of Defense	M	H	X	X	X	X	X	X	X	X	X	X	X	X
US Army	M	H	X	X	X	X	X	X	X	X	X	X	X	X
US Air Force	M	H	X	X	X	X	X	X	X	X	X	X	X	X
US Marine Corps	M	H	X	X	X	X	X	X	X	X	X	X	X	X
US Navy	M	H	X	X	X	X	X	X	X	X	X	X	X	X
Component Commanders	M	M-H	X	X	X	X	X	X	X	X	X	X	X	X
Government Agencies														
Drug Enforcement Agency	L	M	X	X	X	X	X	X		X	X			X
Defense Intelligence Agency	L	M	X	X	X	X	X	X		X	X			X
Central Intelligence Agency	L	M	X	X	X	X	X	X		X	X			X
Federal Bureau of Investigation	L	M	X	X	X	X	X	X		X	X			X
Dept of Homeland Security	L	M	X	X	X	X	X	X		X	X	X		X
US Coast Guard	L	M	X	X	X	X	X	X		X	X	X		X
Alcohol, Tobacco, and Firearms	L	M	X	X	X	X	X	X		X	X			X
Other Nations														
Allies	L	M-H	X	X	X	X	X	X	X	X	X	X	X	X
International Organizations														
United Nations	L	M-H	X	X	X	X	X	X	X	X	X	X	X	X
North Atlantic Treaty Organization	L	M-H	X	X	X	X	X	X	X	X	X	X	X	X
Other Organizations														
Red Cross	L	L		X			X							
International Standards Organizations	L	H	X	X	X	X								
Enemy threats														
Insurgents	M	H	X	X	X	X	X	X	X	X	X	X	X	X
Enemy Forces	M	H	X	X	X	X	X	X	X	X	X	X	X	X
Criminal	M	M	X	X	X	X	X	X	X	X	X	X	X	X
Illegal Immigrants	L	L					X							
Users														
SEAL Teams	M	H		X	X	X	X	X	X	X	X	X	X	X
Rangers	M	H		X	X	X	X	X	X	X	X	X	X	X
Riverine	M	H		X	X	X	X	X	X	X	X	X	X	X
Explosive Ordnance Disposal	M	H		X	X	X	X	X	X	X	X	X	X	X
Maritime Expeditionary Security Force	M	H		X	X	X	X	X	X	X	X	X	X	X

TABLE 4. STAKEHOLDER ANALYSIS.

2.11. FACTORS FOR DESIGN

The SEA-16 project is focused on analyzing the problem at a higher, more conceptual level, and not developing systems engineering products for a detailed system. Therefore, determining detailed requirements that are tied to specific design criteria is not the focus area. Rather, SEA-16 has focused on capabilities and design characteristics that are critical for the success of the architecture.

2.11.1. Overall Architecture Characteristics

Design provides architecture with its notional attributes. Design is more than how something works. Design is how the functions of the system are presented to users so the users can interact with the system's interfaces. These interactions occur at the system boundaries, therefore the system functions are enacted at the boundaries. The following issues occur at the boundaries.

- **Available** The system must be ready and operating in an effective and efficient manner in order to accomplish the mission. There are two factors which affect availability: reliability and maintainability.¹⁴
 - Reliability is the ability to perform the mission as required. Reliability is measured as a probability that the system will accomplish its intended mission.¹⁵ The systems that are part of the architecture will need to be designed and built to operate in the various operational environments that the system may have to operate in. For example, the system will have to perform at sea, in humid climates, in dirty or dusty environments or even possibly in space. Mission accomplishment is a result of systems that can be counted on to perform their intended activities.

¹⁴ Benjamin Blanchard and Wolter Fabrycky, *Systems Engineering and Analysis* (New Jersey, Pearson Prentice Hall, 2006), 370.

¹⁵ Ibid.

- Maintainability is design dependent and relates to the ability of a system to be maintained.¹⁶ There will need to be enough operational assets available at any given time to accomplish the mission. Cost and stowage limitations preclude having vast amounts of spare systems on hand to replace systems that are in need of repair. Therefore, the systems must be capable of being brought back to a fully operational status through corrective maintenance. Ideally, the preventative and condition based maintenance will reduce the amount of corrective maintenance that is required.
- **Survivable** The systems that will comprise the architecture will face enemy and environmental challenges, and the systems must be able to stand up to these challenges. Some of the challenges faced may be chemical, biological, radiation threats, or electromagnetic pulse weapons. The systems will have to be designed to meet the current threat and projected threats.
- **Supportable** The elements of the architecture must be able to be logistically sustained. The sustainability of the systems must not be an afterthought in the design process; rather the sustainability must be a key design parameter. The different elements of the architecture will be deployed throughout the world, therefore, mobility and speed will be important considerations when determining supportability requirements.¹⁷
- **Cost effective** Budgetary constraints in both the United States and allied countries are going to force defense systems to maximize the value that they bring to the fight. The U.S. national deficit is increasing and, according to a Congressional Budget Office estimate, is projected to

¹⁶ Benjamin Blanchard and Wolter Fabrycky, *Systems Engineering and Analysis* (New Jersey, Pearson Prentice Hall, 2006), 418.

¹⁷ Blanchard, Benjamin, S.; Fabrycky, Wolter, J.; "Systems Engineering and Analysis," 4th ed, Pearson Prentice Hall, 2006, pg 510-511.

exceed 82% of the national economy by the year 2019.¹⁸ The vast majority of the increase in the national deficit will be attributed to entitlement spending such as Medicaid, Medicare, and Social Security.¹⁹ A likely place to reduce spending will be on discretionary spending areas of the national budget such as defense spending. Therefore, the development of systems to support the unmanned system architecture must be cost effective. One of the goals of increasing the use of unmanned vehicles is the reduction in manpower costs. Therefore, the costs of the system must not outpace the costs of traditional, manned systems.

- **Flexible** Allow technological advances to be integrated to architecture. Technological advances in unmanned systems, computing capabilities, software enhancements, sensor capabilities, and other areas will enable the systems to improve capabilities as long as the systems are designed to be updated when emerging technology arrives. The systems will have to be designed with the expectation that parts of the system will need to be updated as technology evolves.
- **Interoperable** It will be critical that the system elements can integrate with joint U.S. systems as well as with coalition partner equipment. Recent experiences with the operation of UAVs in Afghanistan and Iraq have led the the Department of Defense to recognize the limitations posed by control systems that are proprietary.²⁰ Proprietary systems allow a particular company's UAV to be able to be controlled by a specific control station that cannot control another company's UAV. In order to achieve effective situational awareness a

¹⁸ Montgomery, Lori, "Deficit Projected To Swell Beyond Earlier Estimates," March 21, 2009, <http://www.washingtonpost.com/wp-dyn/content/article/2009/03/20/AR2009032001820.html>.

¹⁹ Imendorf, Douglas, W. "The Long Term Budget Outlook", Testimony Before Congress, July 16, 2009, http://www.cbo.gov/ftpdocs/104xx/doc10455/Long-TermOutlook_Testimony.1.1.shtm.

²⁰ Defense Industry Daily, "It's Better to Share: Breaking Down UAV GCS Barriers", March 16, 2010, <http://www.defenseindustrydaily.com/uav-ground-control-solutions-06175>

military operator needs to be able to access and utilize the data from multiple UAVs in an operational area. Utilizing different control stations is ineffective and infeasible.

In 2008, the DoD began an effort to acquire a command and control system for UAVs that will control a variety of UAVs from the unmanned helicopter MQ-8 Fire Scout to the long range Global Hawk. The goal is to control multiple UAVs without being impeded by proprietary limitations.²¹

The importance of interoperability has been identified by the North Atlantic Treaty Organization (NATO) through its Standardization Agreement (STANAG) 4586, which “establishes specifications for a common ground station system for UAVs used by NATO military forces. Compliance with STANAG 4586 allows NATO member nations to jointly support military operations using their own UAVs and ground control station equipment. This increases interoperability and allows data and information processed by member nation UAVs to be shared real-time through a common ground interface.²²” For interoperability to be achieved in the 2030 timeframe, the generation of standards must go beyond just UAVs, and extend to commonality between all domains. For example, UAVs, UUVs, UGVs, and USVs should be controllable from a common controller and not have separate, proprietary control systems.

2.11.2. Command and Control Factors

The functional architecture is premised on two top level requirements.

- **Allow knowledge sharing** The sharing of knowledge allows each commander to understand what each other commander in an effort is planning and executing. The shared knowledge allows each commander

²¹.Ibid.

²² Boeing Corporation Media Release, “Boeing Scan Eagle Team Achieves Compliance with NATO UAV Interoperability Standard,” February. 07, 2007, http://www.boeing.com/news/releases/2007/q1/070207a_nr.html.

to direct his assets toward the accomplishment of the mission in a coordinated manner. The more that each commander understands what the other elements are doing, the more likely that the entire force will achieve unity of effort.

Effective knowledge sharing and unity of effort leads to a decentralization of command and an increase in operational tempo. When knowledge sharing is emphasized, commands will be less likely to hoard information. When knowledge is readily available to operators and commanders, the amount of time to make quality decisions is reduced.

- **Enable OODA Loop** Allow monitoring of the situation, understanding of the situation, generation of different courses of action and well informed decision making. The architecture should enable the OODA loop to be executed quicker than the adversary's version of the OODA loop. The C2 system must also allow the tasking and directing of assets, including the capability to provide control. A detailed discussion of the OODA functions is contained in Section 4.1.

2.11.3. Network Factors

- **Interface** Enable interface through interoperability and common communication standards. The interfaces will need to occur at the syntactic and semantic level. The syntactic level is the standardization of data and messaging formats and security tags. Semantic level interoperability is achieved by coordinating doctrine and operational procedures. Interface must be achieved between U.S. agency's systems and coalition systems. Some key interfaces for the sharing of information will be: UV to UV in the same domain and across domains (USV to UUV, UAV to UUV, UGV to UAV, USV to UAV, UGV to USV, UGV to UUV), UV to manned vehicles, UV to C2 nodes, and manned vehicles to C2 nodes.

- **Data fusion** The large amounts of sensors and information sharing devices that will be in the 2030 battlespace present the risk of overwhelming decision makers with information. The network that will handle the dissemination of information must sort and prioritize data into reports that are viewable and intuitive to human intelligence or artificial intelligence as appropriate.
- **Information Assurance** The ability to secure data is imperative to conducting operations that rely highly on networked operations. Information assurance must be an integral design characteristic of the systems which comprise the network. Information will provide confidentiality, authenticity, and integrity to the information in the network.
- **Scalability** One of the objectives of the architecture is to allow communication between assets that are in the same geographical region, but also between assets that are beyond line of sight. Long range communication and information sharing will be an important capability. The network must provide regional to global coverage.
- **Resilience to interference and jamming** The success of the architecture requires heavy reliance on the unimpeded use of the radio frequency (RF) spectrum. Although RF communications will enable collaboration between critical nodes, the key enabler is also vulnerable to enemy jamming. The system must have efficient tactical communications that allow operation in low to high electronic warfare threat environments.
- **Cross medium broadcast**—communicating across mediums is necessary to achieve a seamless integration between vessels operating in different mediums. For example, a UUV must be able to communicate to a UAV and to a C2 node located on the sea surface or on land.
- **Close to real time communications** Latency and bandwidth affect the network speed. Latency refers to delays in the network as data is

processed. Low latency networks suffer lower wait times for data processing. Bandwidth is the overall capacity of the network and is measured in throughput per period of time (bits per second). The higher the bandwidth the more information that can be transferred quickly. Latency can affect bandwidth as high latency can create bottlenecks that can decrease bandwidth.²³ The goal of the network is a geographically dispersed network with real time communications. Therefore, a low latency network with high bandwidth is required.

2.11.4. Operational Factors

- **High endurance** The level of endurance of a system will determine how often the asset has to turn over to replacement assets. The longer the asset's endurance the less frequently turnover is required, thus the fewer assets that are required. The ability to stay on station for longer periods of time will reduce the number of systems required to maintain continuous station keeping. Improved combustible engines, improved batteries, and lighter materials may lead to improved endurance. Unmanned vehicles operating in the battlespace will conduct surveillance and force protection missions which require assets to remain on station continuously. A discussion of the missions and types of UAVs are contained in [Figure 8](#).
- **Multiple levels of autonomy** The system must allow low to high autonomy operations. The required levels of autonomy are based on mission requirements and bandwidth requirements. A description on levels of autonomy is contained in [Section 3.3](#).
- **Mission capable assets** The UMS used to execute the required missions must be capable of defeating enemy threats. For example, UVs must have the required level of stealth, fire power, and sensor capabilities.

²³ Mitchell, Bradley, "Network Bandwidth and Latency", http://compnetworking.about.com/od/speedtests/a/network_latency.htm.

3.0. SYSTEMS ANALYSIS

3.1. COMMAND AND CONTROL CONCEPT

3.1.1. Boyd's OODA Loop

The OODA (Observe, Orient, Decide and Act) Loop, as shown in [Figure 7](#), is an information strategy concept for information warfare developed by Colonel John Boyd in the early 1970's. Boyd developed the theory based on his experience as a fighter pilot and work on energy maneuverability. He initially used it to explain victory in air-to-air combat, but in the last years of his career, he expanded his OODA loop theory into a grand strategy that would defeat an enemy strategically by “psychological” paralysis.

Colonel Boyd viewed the enemy as a system that acts through a decision making process based on observations of the world around it. The main objective is to complete the OODA loop process at a faster tempo than the enemy and to take action to lengthen the enemy's loop, causing the enemy to be unable to react to anything that is happening to him.²⁴

SEA-16 chose to utilize Colonel Boyd's OODA loop as a guide for several reasons. First, the model is generally accepted amongst DoD organizations and is understood by most commanders. The model is simple and time tested. The model is also comprehensive enough to cover the stimulus to order cycle. Through the functional decomposition of OODA, the model adequately covers the key elements of the C2 definition including: planning, organizing, directing, coordinating, and controlling forces in order to accomplish a mission.

Using Boyd's OODA Loop as a guide, the model was applied to unmanned vehicles and decomposed how each step in the OODA process is conducted. A full description of the functional architecture is contained in [Section 4](#).

²⁴ Value Based Management ,Information Warfare OODA Loop,
http://www.valuebasedmanagement.net/methods_boyd_ooda_loop.html

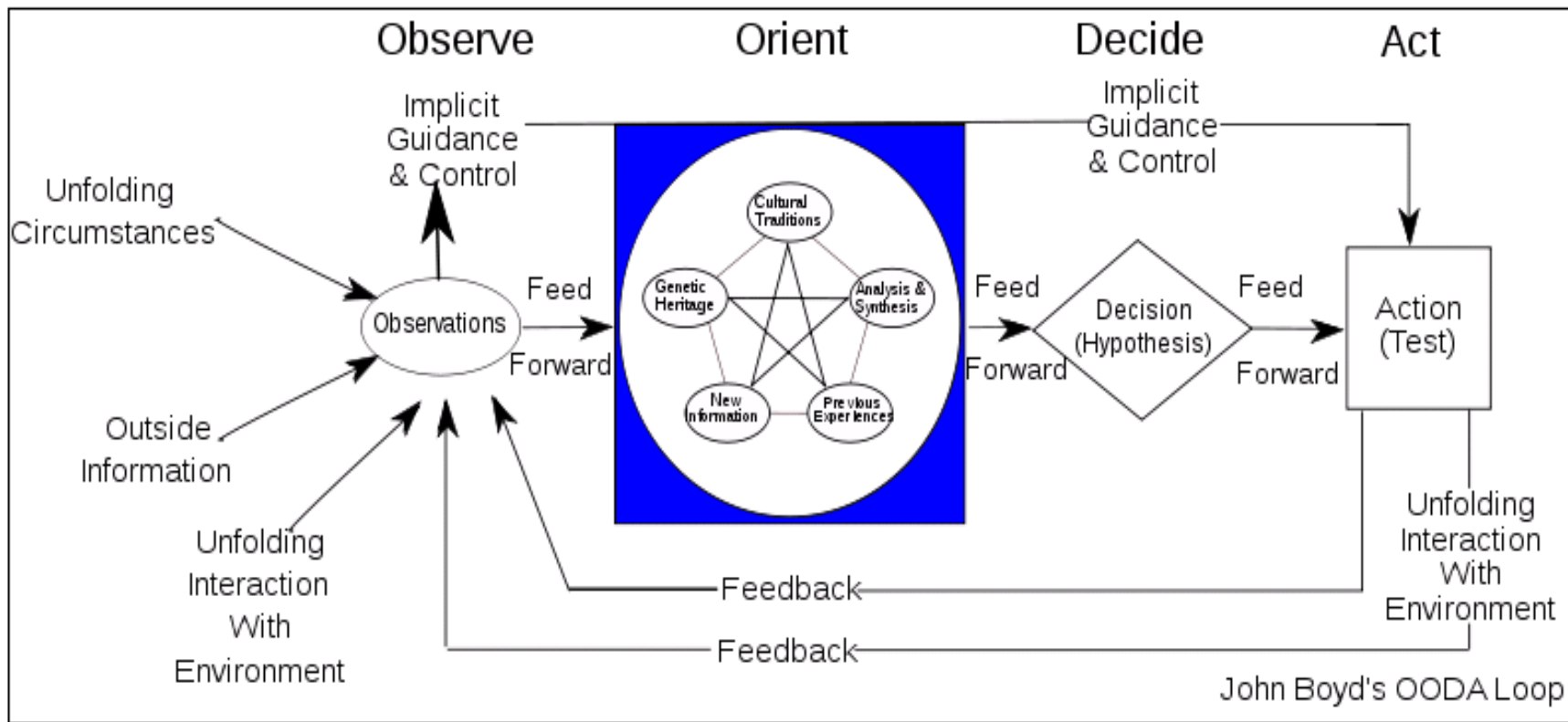

Figure 7. Boyd's OODA Loop²⁵

²⁵ Brehmer, Berndt, *The Dynamic OODA Loop: Amalgamating Boyd's OODA Loop and the Cybernetic Approach to Command and Control*, http://www.dodccrp.org/events/10th_ICCRTS/CD/papers/365.pdf, 4

3.2. OVERVIEW OF UNMANNED SYSTEMS (UMS)

3.2.1. Range of UMS

Unmanned Vehicles are generally classified into three types, based on the medium in which they perform their roles in normal operating modes. These classifications of vehicles are:

- Unmanned Aerial Vehicles (UAV)
- Unmanned Ground Vehicles (UGV)
- Unmanned Maritime Vehicles
 - Unmanned Surface Vehicles (USV)
 - Unmanned Undersea Vehicles (UUV)
- Unmanned Outer Space Vehicles (UOSV)

The perception and roles of UMS have evolved greatly over the past several years. “UAVs were considered exotic toys and not essential tools for victory on the modern battlefield. This all changed as the U.S. demand for surveillance assets soared and its fleet of UAVs expanded by leaps and bounds.”²⁶ Unmanned vehicles are now seen less and less as a completely separate entity within the Department of Defense, and have slowly gained a high level of acceptance and recognition as systems with improving reliability. With use of UAV’s increasing from about 1,000 flight hours in 1987 to over 600,000 flight hours in 2008, their presence in combat has grown exponentially.

²⁶ Dickerson, Larry. *New Respect for UAVs*. Aviation Week & Space Technology. 26 January 2009, <http://www.aviationweek.com>.

The number of unmanned vehicles in service and in development continues to increase. [Figure 8](#) gives an overall view of the proliferation of UMS across all mission areas, and [Table 5](#) displays the number of named UMS identified by Joint Capability Area. The sheer number of vehicle types is indicative of how much UMS have penetrated nearly every aspect of the military. Current guidance on unmanned vehicles reflects a rising level of acceptance in the military towards UMS. Now, when considering the use of UAV's, they “should be treated similarly to manned systems with regard to the established doctrinal warfighting principles.”²⁷ In the maritime domain, unmanned vehicles are formally considered as a fires resource alongside more traditional maritime platforms.

A survey of current and future UMS is contained in [Appendix B](#).

Unmanned Systems by JCA and Domain					
Numbers of Named Systems					
Battlespace Awareness	84	Corporate Management & Support	1	Logistics	28
▪ Air	30	▪ Air	0	▪ Air	6
▪ Ground	38	▪ Ground	1	▪ Ground	22
▪ Maritime	16	▪ Maritime	0	▪ Maritime	0
Building Partnerships	32	Force Application	42	Net-Centric	18
▪ Air	6	▪ Air	22	▪ Air	8
▪ Ground	18	▪ Ground	10	▪ Ground	10
▪ Maritime	8	▪ Maritime	10	▪ Maritime	0
Command & Control	20	Force Support	20	Protection	66
▪ Air	8	▪ Air	2	▪ Air	11
▪ Ground	12	▪ Ground	18	▪ Ground	42
▪ Maritime	0	▪ Maritime	0	▪ Maritime	13

TABLE 5. NUMBERS OF NAMED UMS.²⁸

²⁷ Joint Publication 3-30. Command and Control for Joint Air Operations. 12 January 2010. Fig. III-32

²⁸ U.S. Department of Defense. FY2009–2034 Unmanned Systems Integrated Roadmap. p. 8.

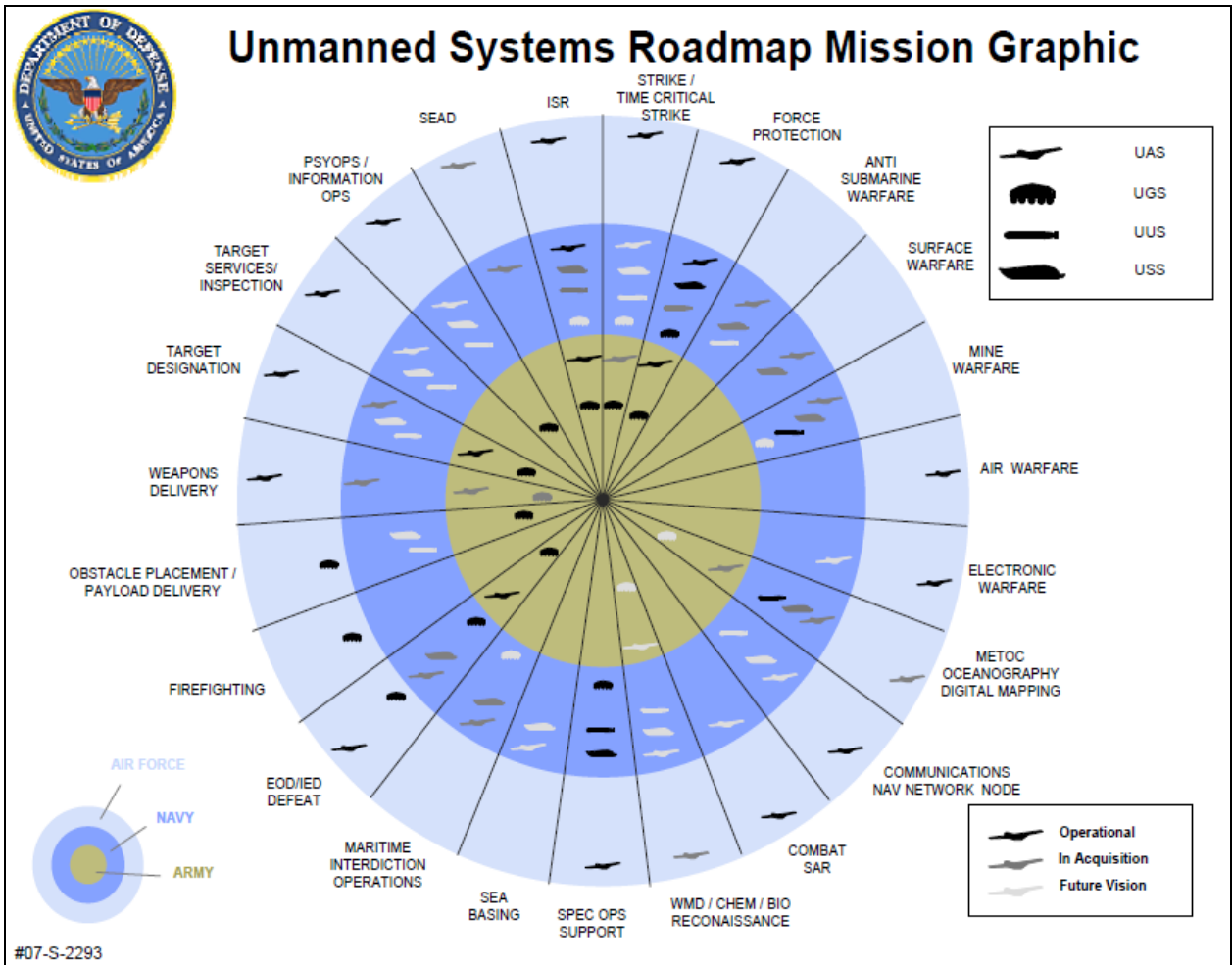

Figure 8. Missions of Unmanned Systems²⁹

3.2.2. Classes of UMS Classes of UMS

3.2.2.1. Unmanned Aerial Vehicles (UAV)

There are five categories of Unmanned Aerial Vehicles³⁰, which are distinguished by three primary parameters: Maximum Gross Takeoff Weight, Normal Operating Altitude, and Speed. These categories are shown in [Figure 9](#). With the exception of Group 1, which have low altitudes and are typically small, and fly low and

²⁹ Weatherington, Dyke D. "Unmanned Systems Roadmap" Presentation. Accessed 1 April 2010 at http://www.dtic.mil/ndia/2007psa_peo/Weatherington.pdf

³⁰ Joint Publication 3-30. Command and Control for Joint Air Operations. 12 January 2010. Fig. III-15.

slow, these vehicles now integrate completely in Air Operations despite the absence of an onboard pilot.

UNMANNED AIRCRAFT SYSTEMS CATEGORIZATION CHART				
UA Category	Maximum Gross Takeoff Weight (lbs)	Normal Operating Altitude (ft)	Speed (KIAS)	Representative UAS
Group 1	0-20	< 1200 AGL	100 kts	WASP III, TACMAV RQ-14A/B, BUSTER, BATCAM, RQ-11B, FPASS, RQ16A, Pointer, Aqua/Terra Puma
Group 2	21-55	< 3500 AGL	< 250	ScanEagle, Silver Fox, Aerosonde
Group 3	< 1320	< 18,000 MSL	< 250	RQ-7B Shadow, RQ-15 Neptune, XPV-1 Tern, XPV-2 Mako
Group 4	> 1320		Any Airspeed	MQ-5B Hunter, MQ-8B Fire Scout, MQ-1C ERMP, MQ-1A/B/C Predator
Group 5	> 1320	> 18,000 MSL	Any Airspeed	MQ-9 Reaper, RQ-4 Global Hawk, RQ-4N BAMS

LEGEND			
AGL	above ground level	lbs	pounds
ft	feet	MSL	mean sea level
KIAS	knots indicated airspeed	UA	unmanned aircraft
kts	knots	UAS	unmanned aircraft system

Figure 9. Categories of Unmanned Aerial Vehicles

3.2.2.2. Unmanned Ground Vehicles (UGV)

Seven classes of UGVs were proposed by the Joint Robotic Program in 2001 based solely on the weight of the vehicles. These classes of vehicles are shown in [Figure 10](#).

Micro: < 8 pounds
Miniature: 8-30 pounds
Small (light): 31-400 pounds
Small (medium): 401-2,500 pounds
Small (heavy): 2,501-20,000 pounds
Medium: 20,001-30,000 pounds
Large: >30,000 pounds

Figure 10. Classes of Unmanned Ground Vehicles





3.2.2.3. *Maritime Unmanned Vehicles*

Maritime Unmanned Vehicles are separated into two categories: Unmanned Surface Vehicles and Unmanned Undersea Vehicles.

3.2.2.3.1. Unmanned Surface Vehicles (USV)

Unmanned Surface Vessels are divided into four primary classes: X-Class, Harbor Class, Snorkeler Class, and Fleet Class.³¹ These four classes are distinguished primarily by their differences in length and mode of operation (surface or semi-submersible). In [Figure 11](#), these classes are paired with specific primary and secondary missions.

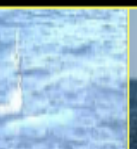
³¹ The Navy Unmanned Surface Vehicle (USV) Master Plan. 23 July 2007. p. xii.

							
USV MP Priority	Joint Capability Area (JCA)	Seapower Pillar	USV Mission	X-Class (small)	Harbor Class (7M)	Snorkeler Class (7M SS)	Fleet Class (11M)
1	Battle Space Awareness (BSA) / Access/ Littoral Control	Sea Shield	Mine Countermeasures (MCM)	Not Seen as a mission for class	MCM Delivery, Search / Neutralization	MCM Search, Towed, Delivery, Neutralization	MCM Sweep, Delivery, Neutralization
2	BSA / Access/ Littoral Control	Sea Shield	Anti-Submarine Warfare (ASW)		Maritime Shield	Protected Passage and Maritime Shield	
3	BSA, HLD, Non-Trad Ops, 7 Others	FORCENet	Maritime Security		ISR/ Gun Payloads	7M Payloads	
4	BSA / Access/ Littoral Control	Sea Shield	Surface Warfare (SUW)		SUW, Gun	SUW (Torpedo), Option	SUW, Gun & Torpedo
5	BSA / Access/ Littoral Control/ Non-Trad Ops	Sea Strike	Special Operation Forces (SOF) Support	SOF Support	SOF Support	Other Delivery Missions (SOF)	
6	BSA, C&C, Net Ops, IO, Non-Trad Ops, Access, Littoral Control	Sea Strike	Electronic Warfare	Other IO	High Power EW	High Power EW	
7	BSA, Stability, Non-Trad Ops, Littoral Control	Sea Shield	Maritime Interdiction Operations (MIO) Support	MIO USV for 11M L&R	ISR/ Gun Payloads		



	Not Seen as a mission for class
	Secondary Mission for class
	Primary Mission for class

Figure 11. Classes and Missions of Unmanned Surface Vehicles³²

3.2.2.3.2. Unmanned Undersea Vehicles (UUV)

There are four classes of UUVs that were recommended in 2004, generally based on the size and weight of the platforms. Described in [Figure 12](#), these four classes of UUVs are: Man-Portable, Light Weight Vehicle (LWV), Heavy Weight Vehicle (HWV), and Large Class.

³² The Navy Unmanned Surface Vehicle (USV) Master Plan. 23 July 2007. p. D-11

Class	Diameter (inches)	Displacement (lbs.)	Endurance High Hotel Load (hours)	Endurance Low Hotel Load (hours)	Payload (ft ³)
Man-Portable	3 - 9	< 100	< 10	10 - 20	< 0.25
LWV	12.75	~ 500	10 - 20	20 - 40	1 - 3
HWV	21	< 3,000	20 - 50	40 - 80	4 - 6
Large	> 36	~ 20,000	100 - 300	>> 400	15 - 30 + External Stores

Figure 12. Parameters of Four Classes of Unmanned Underwater Vehicles³³

3.2.3.4. *Unmanned Outer Space Vehicles (UOSV)*

There are no specific classes of unmanned outer space vehicles (UOSV), but categories include satellites and resupply vehicles.

3.2.3. Implications of Using UMS

3.2.3.1. *Advantages of UMS*

There are many advantages to utilizing UMS for military applications.

- Protect human life: Unmanned vehicles can accomplish high risk missions that would otherwise risk human life. For example, in Iraq, many improvised explosive devices were detonated with the help of unmanned ground vehicles. Unmanned vehicles accomplish the dull, dirty, and dangerous missions that can put a pilot's life at risk.³⁴

³³ The Navy Unmanned Undersea Vehicle (UUV) Master Plan. 9 November 2004. p. 67.

³⁴ Unmanned Aerial Vehicles: Background Issues for Congress, April 25, 2003, page 5, <http://www.fas.org/irp/crs/RL31872.pdf>

- Reduce manpower: Unmanned vehicles can accomplish missions that would otherwise require humans to be in manned vehicles.
- Extend combat capabilities: Unmanned vehicles can supplement a combat element and allow forward surveillance, strike, or other combat capability.
- Increased time on station: Unmanned vehicles are not limited by human endurance during missions.
- Generally smaller than manned platforms: Unmanned vehicles do not have to account for human passengers and or comfort, thus can be made smaller.
- Stowage ease: The smaller size of UMSs allows less stowage space.

3.2.3.2. *Disadvantages of UMS*

While there are some strong advantages to using UMS, there are also some disadvantages that must be recognized.

- Technology gaps: Machines have not been advanced to the point where they can match human intelligence.
- Ethical questions: As more and more UMSs are utilized in strike missions, the question arises as to when can a machine kill a human on its own?
- Command and Control challenges: Current technology limits control of UMSs to one controller per UMS. As more and more unmanned vehicles are used, many UMSs must be able to be controlled by a common controller.
- Flexibility of mission: A human operated vehicle can adapt to the environment and change its mission given the threat and tasking.

- Human is removed from the local OODA Loop. The human is not in the scenario and must rely on sensor data that does not allow first hand human involvement.

3.3. AUTONOMY LEVELS FOR UNMANNED SYSTEMS (ALFUS)

3.3.1. Definitions of Autonomy

3.3.1.1. Dictionary Definition of Autonomy

The condition or quality of being independent or self-governing.³⁵

3.3.1.2. SEA-16 Definition of Autonomy

“Operations of an unmanned system (UMS) wherein the UMS receives its mission from the human and accomplishes that mission with or without further Human-Robot Interaction (HRI). The level of HRI, along with other factors such as mission complexity, and environmental difficulty, determine the level of autonomy for the UMS. Finer-grained autonomy level designations can also be applied to the tasks, lower in scope than mission.”³⁶

3.3.2. ALFUS Framework

The autonomy of a UMS is “characterized by the missions that the system is capable of performing, the environments within which the missions are performed, and human independence that can be allowed in the performance of the missions.”

³⁵ Marckwardt, Albert H. “Webster Comprehensive Dictionary, Encyclopedic Edition”, J.G. Ferguson Publishing Company, Chicago, IL, 1997, p. 99.

³⁶ Huang, Hui-Min, “Autonomy Levels for Unmanned Systems (ALFUS) Framework, Volume I: Terminology”, Intelligent System Division, National Institute of Standards and Technology, Sept 2004, p. 8.

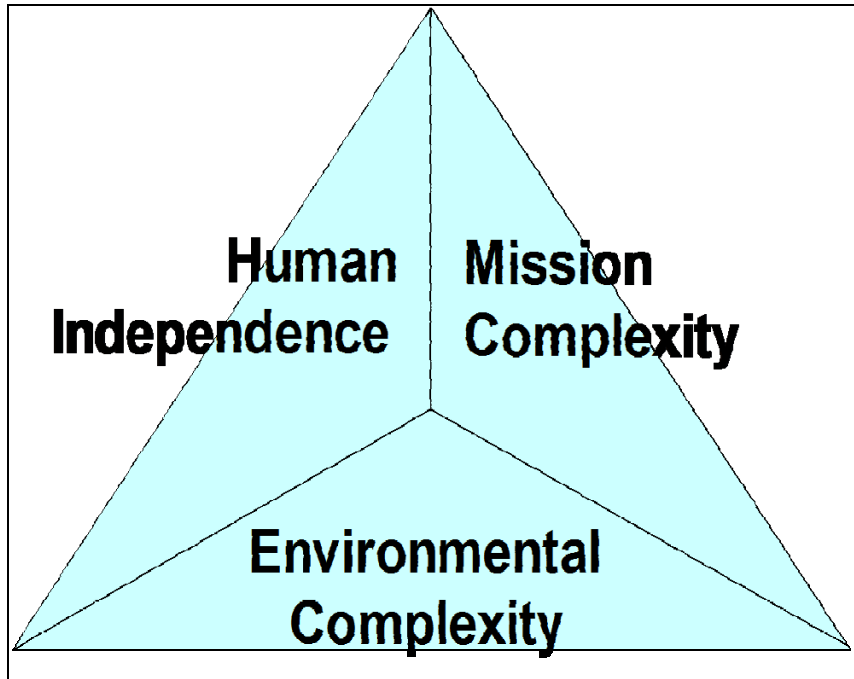

Figure 13. Aspects of the ALFUS Framework

The ALFUS Framework, as depicted in [Figure 13.](#), highlights that levels of autonomy are characterized by three aspects: Human Independence (HI), Mission Complexity (MC), and Environmental Complexity (EC). These three aspects can be further detailed by assigning a set of metrics in order to complete the specification, evaluation, measurement, and analysis of the specific UMS missions. The Human Independence axis specifically addresses the level of autonomy while the Mission and Environmental Complexity provide context. See [Section 3.3.3.](#) for more detailed information on Human Independence, Mission Complexity and Environmental Complexity.

The ALFUS framework allows for the decomposition of the Unmanned System and their missions with respect to requirements, capabilities, levels of complexity, and detailed sophistication. Additionally the framework enables the operator to define the UMS's autonomous operational modes.³⁷

³⁷ Huang, Hui-Min, "Autonomy Levels for Unmanned Systems (ALFUS) Framework, Volume II: Framework Models", Intelligent System Division, National Institute of Standards and Technology, Dec 2007, p. 17.

3.3.3. ALFUS Characteristics

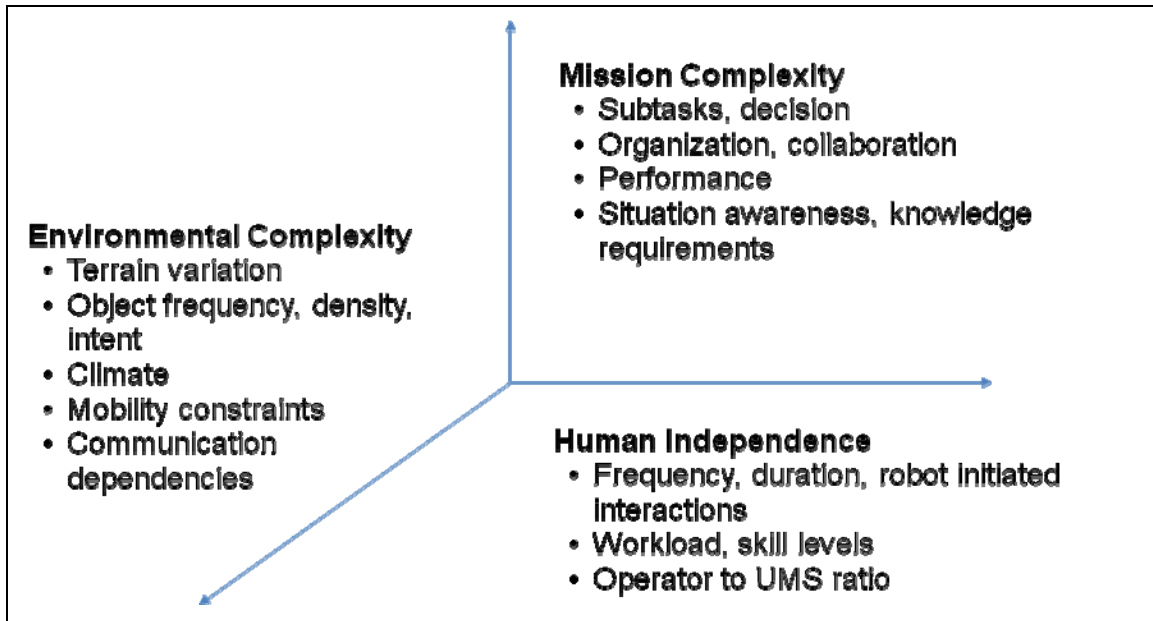

Figure 14. ALFUS Characteristics³⁸

The three aspects of Autonomy Levels for Unmanned Systems, as shown in [Figure 14.](#), are analyzed by characteristics that determine the level of autonomy.

Human Independence (HI) is characterized by the frequency and duration of robot initiated interactions, the workload and skill levels required for system operation, and the operator to UMS ratio.

Mission Complexity (MC) can be characterized by the subtasks and decisions required for the specific mission. Additionally, the organization, including the collaboration with the organization, can be measured. The specific performance of the UMS within the mission space can be used to characterize the Mission Complexity. Finally, the allowed situational awareness and knowledge requirements can be used as a metric.

Environmental Complexity (EC), probably the biggest unknown during operations, is essential in determining the level of autonomy. The most common metrics

³⁸ Huang, Hui-Min, “Autonomy Levels for Unmanned Systems (ALFUS)” brief, Intelligent System Division, National Institute of Standards and Technology, Dec 2007, p. 8.

for Environmental Complexity are terrain variation; object frequency, density and intent; climate variability, mobility constraints; and communication limitations and dependencies.

3.3.4. ALFUS and Bandwidth

An additional topic of study was to determine the correlation between ALFUS and the amount of bandwidth required to support operations. As shown in [Figure 15.](#), the amount of bandwidth required is directly related to the amount of Operator Authority needed to control the UMS. High Operator Authority will require constant communication between the operator and the UMS this in turn will require large amounts of bandwidth for the transmission of control data. As shown, there is an inverse relationship between Operator Authority and Computer Autonomy (for example the lower requirement for Operator Authority the higher the allowable Computer Autonomy); therefore there is also an inverse functional relationship between ALFUS and bandwidth.

Additionally, with low bandwidth (high autonomy) the communications cost will be low, due to reduced equipment usage, but software expenditures will be big due to the large cost of developing high levels of autonomy. With high bandwidth (low autonomy) the software costs will be low, due to low development costs, but the communication costs will be high due to the requirement for versatile equipment.

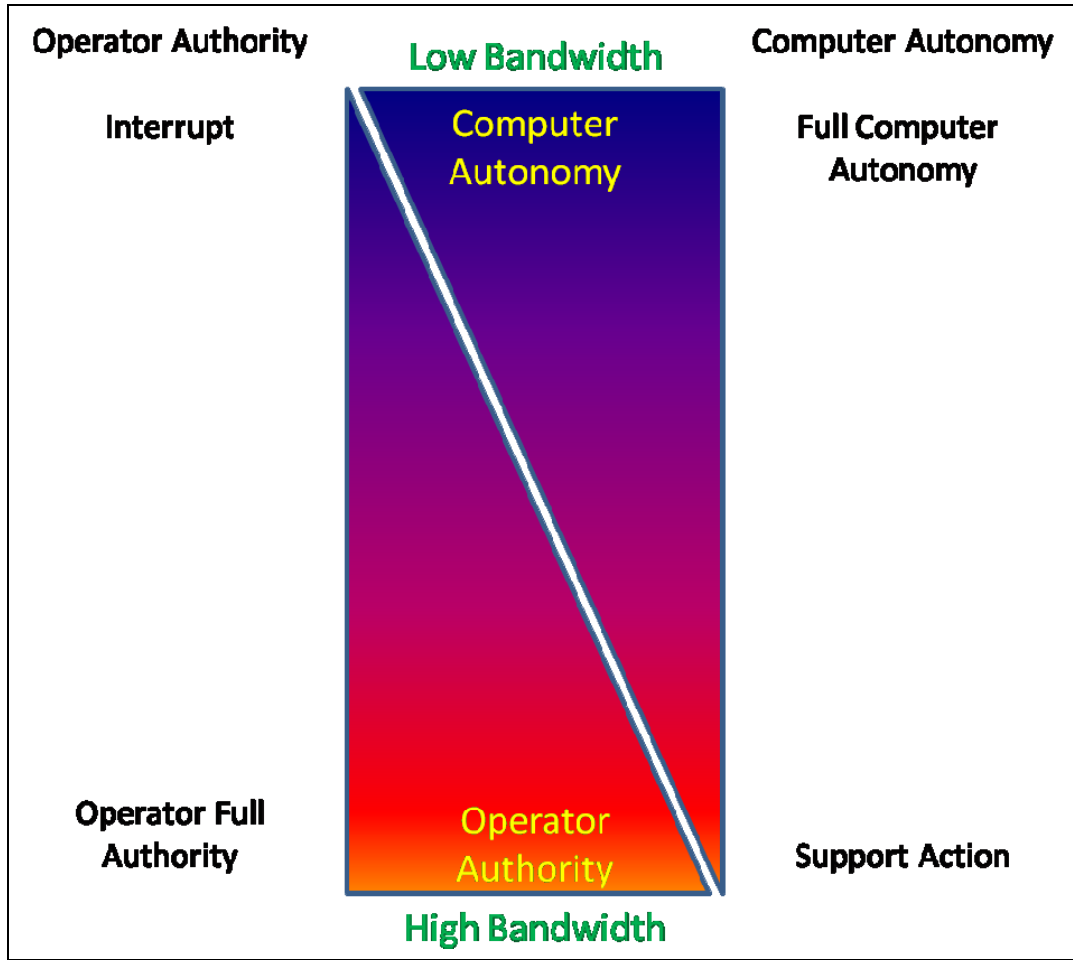

Figure 15. ALFUS vs Bandwidth.

3.3.5. Autonomy Levels for Unmanned Systems (ALFUS)

As shown in [Table 6 &7](#) (ALFUS Levels 5-10 and 0-4)³⁹, Autonomy Levels for Unmanned Systems has been broken down to levels 0 – 10, covering Remotely Piloted Vehicles to Fully Autonomous Vehicles. Each level has been detailed further by the Level Descriptor and the OODA (Observe, Orient, Decide and Act) Loop. Each table defines the levels with reference to the OODA Loop; allowing for the classification of each UMS capability to a specific autonomy level. These autonomy levels are essential in developing and running the simulations to test the overall architecture. As one of the inputs to the simulation, an accurate accounting of each UMS’s autonomy level is essential due to the communications demand requirements per vehicle.

³⁹ Huang, Hui-Min, “Autonomy Levels for Unmanned Systems (ALFUS)” brief, Intelligent System Division, National Institute of Standards and Technology, Dec 2007, p. 25.

Level	Level Descriptor	Observe	Orient	Decide	Act
		Perception/Situational Awareness	Analysis/Coordination	Decision Making	Capability
10	Fully Autonomous	Cognizant of all within Battlespace	Coordinates as necessary	Capable of total independence	Requires little guidance to do job
9	Battlespace Swarm Cognizance	Battlespace Inference - Intent of self and others (allies and foes) Complex/intense environment - on-board tracking	Strategic group goals assigned Enemy strategy inferred	Distributed tactical group planning Individual determination of tactical goal Individual task planning/execution Choose tactical targets	Group accomplishment of strategic goal with no supervisory assistance
8	Battlespace Cognizance	Proximity inference - intent of self and others (allies and foes) Reduced dependence upon off-board data	Strategic group goals assigned Enemy tactics inferred	Coordinated tactical group planning Individual task planning/execution Choose targets of opportunity	Group accomplishment of strategic goal with minimal supervisory (example: go SCUD hunting)
7	Battlespace Knowledge	Short track awareness - History and predictive battlespace data in limited range, timeframe, and numbers Limited inference supplemented by off-board data	Tactical group goals assigned Enemy trajectory estimated	Individual task planning/execution to meet goals	Group accomplishment of tactical goal with minimal supervisory assistance
6	Real Time Multi-Vehicle Cooperation	Ranged awareness - on-board sensing for long range, supplemented by off-board data	Tactical group goals assigned Enemy location sense/estimated	Coordinated trajectory planning and execution to meet goal - group optimization	Group accomplishment of tactical goal with minimal supervisory assistance
5	Real Time Multi-Vehicle Coordination	Sensed awareness - Local sensors to detect others, fused with off-board data	Tactical group plan assigned RT Health diagnosis; ability to compensate for most failures and flight conditions; Ability to predict onset of failures (eg Prognostic Health Mgmt) Group diagnosis and resource management	On-board trajectory replanning - optimizes for current and predictive conditions Collision avoidance	Group accomplishment of tactical plan as externally assigned Air collision avoidance Possible close air space separation (1 - 100 yds) for AAR, formation in non-threat conditions

TABLE 6. ALFUS LEVELS 5-10.⁴⁰

⁴⁰ http://www.isd.mel.nist.gov/projects/autonomy_levels/ALFUS-Bg-web2.pps

Level	Level Descriptor	Observe	Orient	Decide	Act
		Perception/Situational Awareness	Analysis/Coordination	Decision Making	Capability
4	Fault/Event Adaptive Vehicle	Deliberate awareness - allies communicate data	Tactical plan assigned Assigned Rules of Engagement RT Health Diagnosis; ability to compensate for most failures and flight conditions - inner loop changes reflected in outer loop performance	On-board trajectory replanning - event driven Self resource management Deconfliction	Self accomplishment of tactical plan as externally assigned Medium vehicle airspace separation (100's of yds)
3	Robust Response to Real Time Faults/Events	Health/status history and models	Tactical plan assigned RT Health Diagnostis (What is the extent of the problem?) Ability to compensate for most control failure and flight conditions (ie adaptive inner-loop control)	Evaluate status vs required mission capabilities Abort/RTB if insufficient	Self accomplishment of tactical plan as externally assigned
2	Changeable Missions	Health/status sensors	RT Health diagnosis (Do I have problems?) Off-board replan (as required)	Execute preprogrammed or uploaded plans in response to mission and health conditions	Self accomplishment of tactical plan as externally assigned
1	Execute Preplanned Mission	Preloaded mission data Flight control and navigation sensing	Pre/Post Flight BIT (Built in Test) Report status	Preprogrammed mission and abort plans	Wide airspace separation requirements (miles)
0	Remotely Piloted Vehicle	Flight control (altitude, rates) sensing Nose camera	Telemetered data Remote pilot commands	N/A	Contol by remote pilot

TABLE 7. ALFUS LEVELS 0-4.⁴¹

⁴¹ http://www.isd.mel.nist.gov/projects/autonomy_levels/ALFUS-Bg-web2.pps

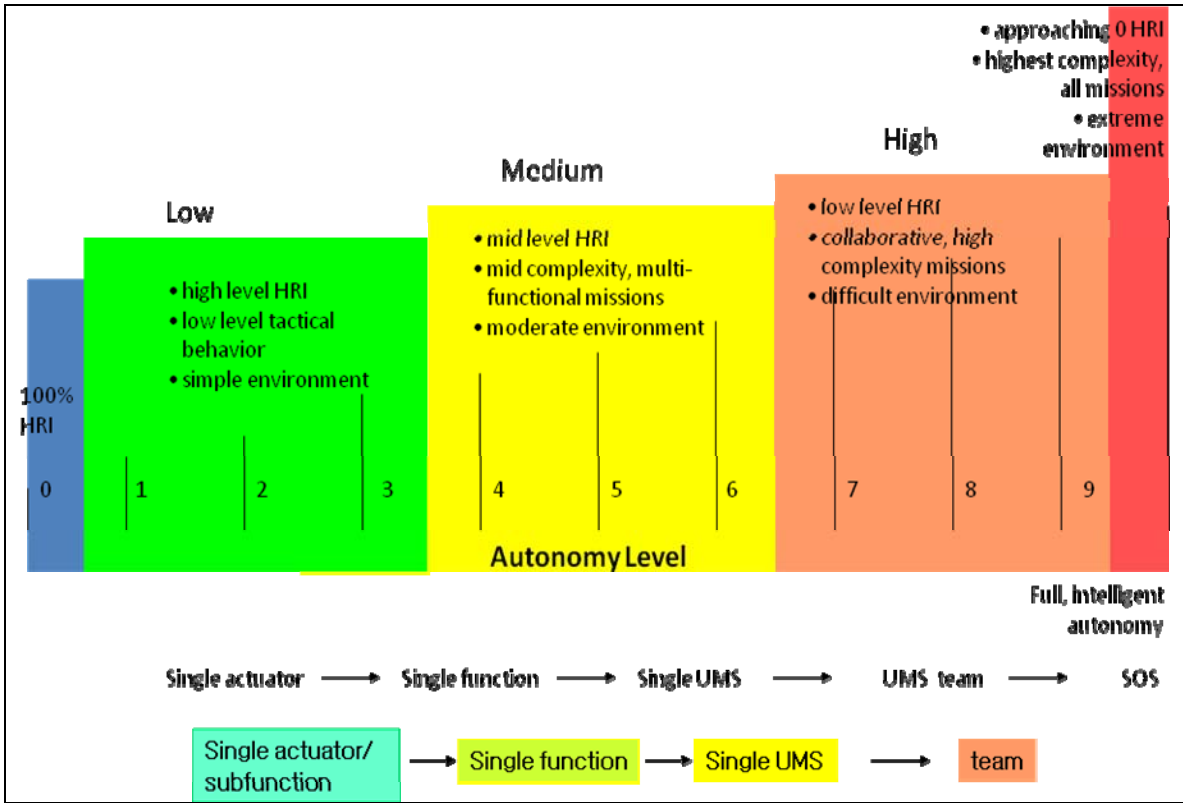

Figure 16. ALFUS Simplification⁴²

In order to simplify the simulation the Autonomy Group used the model developed by the National Institute of Standards and Technology. As shown in [Figure 16.](#), the eleven separate levels are further decomposed into three main levels (Low, Medium, and High). To accomplish this, the extreme levels 0 and 10 were removed (due to the lack of applicability for this project) and the remaining nine levels were grouped into three levels. This reduction of complexity simplified the simulation phase of the project. Each of the three levels was defined by the amount of Human Interaction (HI), Mission Complexity (MC), and Environmental Complexity (EC).

⁴² Huang, Hui-Min, “Autonomy Levels for Unmanned Systems (ALFUS)” brief, Intelligent System Division, National Institute of Standards and Technology, Dec 2007, p. 25

3.4. MAN IN THE LOOP ANALYSIS

To determine the role of humans and machines within a sophisticated system, it was necessary to examine the general characteristics of humans and machines in order to better understand where their capabilities within a process should be allocated. Both have inherent qualities that can be exploited within a system to provide the greatest utility. Equivalently, they have weaknesses that system design should attempt to marginalize. Within a Command and Control system, all of these qualities can affect every level of functionality, and when they are well-balanced, a truly efficient system design can be realized.

Currently, there are three basic categories of functional allocation for humans and machines.⁴³

- Comparison allocation
- Leftover allocation
- Economic allocation

Comparison allocation is a method of making general comparisons of human and machine capabilities in order to allocate system functions. Leftover allocation is primarily a vehicle for assigning roles to humans where machines functionality does not exist. Economic allocation can be difficult to perform, due to the various costs that must be identified and considered, but allocation is quantitative, and not a “judgment” by the systems architect. Comparison allocation is more complicated than either Leftover or Economic allocation, as the decision on whether a human or machine should perform a function is purely a qualitative judgment. Inagaki states there is a need for “a systematic way of thinking and methodology that can investigate and evaluate design of human-machine collaborations in a quantitative manner with appropriate precision.” This man-in-the-loop analysis was performed to identify concepts and methods that can be applied while conducting Comparison allocation.

⁴³ Inagaki, T. Human-Machine Collaboration for Safety and Comfort. Presented to ENRI International Workshop on ATM/CNS. 2009. p. 1.

3.4.1. Human and Machine Strength Comparison

For many years, scholars have attempted to compare the strengths and weaknesses of humans to those of machines. One of the pioneers in this research was Paul M. Fitts. In 1951, he developed one of the first lists that identified the strengths of humans and machines with respect to one another. Fitts' simple comparison is shown in [Figure 17](#).

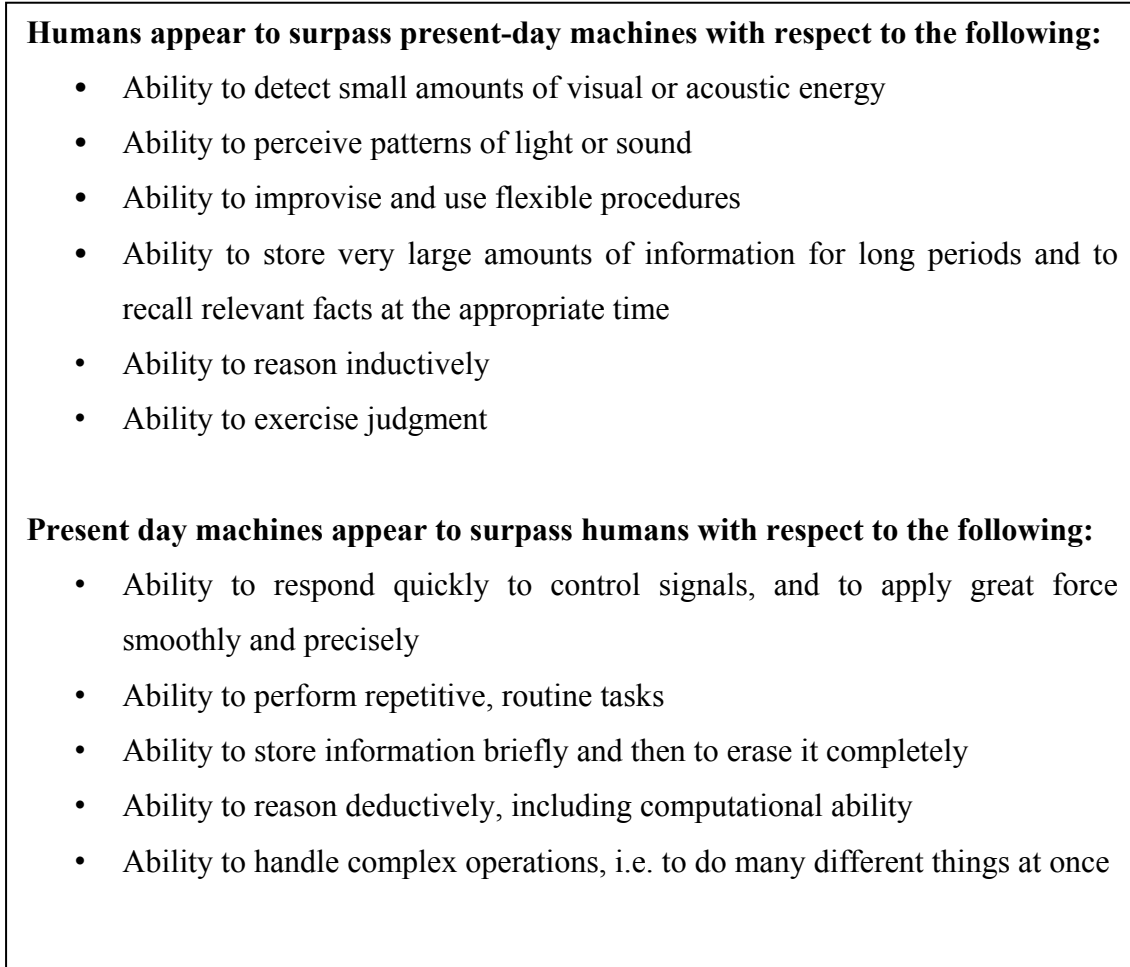

Figure 17. Fitts' List⁴⁴

The Department of Defense *Human Engineering Program Processes and Procedures* is a modern take on this subject.⁴⁵ This listing, shown in [Figure 18](#), and

⁴⁴ Buede, Dennis M., *The Engineering Design of Systems: Models and Methods*. John Wiley & Sons, New York, NY. p. 253.

⁴⁵ U.S. Department of Defense. MIL-HDBK-46855A (*Human Engineering Program Processes and Procedures*). 17 May 1999. p. 153.

[Figure 19](#) describes the functions in which humans and machines excel. This assessment of humans and machines does not differ greatly from the generalizations made in Fitts' List.

Sadly, the strengths of humans as assessed in 1951 have not changed over the years. What is noteworthy is the similarity of the strengths of machines, which has not changed greatly despite tremendous developments in technology over the past several decades. Because of this, the strengths of humans and machines will remain nearly identical in 2030, and can be applied for future system development.

- Detection of certain forms of very low energy levels
- Sensitivity to an extremely wide variety of stimuli
- Perceiving patterns and making generalizations about them
- Ability to store large amounts of information for long periods - and recalling relevant facts at appropriate moments
- Ability to exercise judgment where events cannot be completely defined
- Improvising and adopting flexible procedures
- Ability to react to unexpected low-probability events
- Applying originality in solving problems: i.e., alternative solutions
- Ability to profit from experience and alter course of action
- Ability to perform fine manipulations, especially where misalignment appears unexpected
- Ability to continue to perform when overloaded
- Ability to reason inductively

Figure 18. DoD-Identified Functions Where Humans Excel⁴⁶

⁴⁶ Ibid.

- Monitoring (both men and machines)
- Performing routine, repetitive, or very precise operations
- Responding very quickly to control signals
- Storing and recalling large amounts of information in short time-periods
- Performing complex and rapid computation with high accuracy
- Sensitivity to stimuli beyond the range of human sensitivity (infrared, radio waves.)
- Doing many different things at one time
- Exerting large amounts of force smoothly and precisely
- Insensitivity to extraneous factors
- Ability to repeat operations very rapidly, continuously, and precisely the same way over a long period
- Operating in environments which are hostile to man or beyond human tolerance
- Deductive processes

Figure 19. DoD-Identified Functions Where Machines Excel⁴⁷

⁴⁷ Ibid.

3.4.2. Sources of Human and Mechanical Error

An additional consideration that must be made when allocating functions to humans or machines is the general types of errors that are possible for each of them. [Table 8](#) lists common sources of human and machine error.

It is difficult to measure human error, especially because each human has differing levels of experience, tolerance, and effort. Studies of mechanical error are much more likely to be quantifiable, as components often meet exact specifications and historical performance can be analyzed.

Sources of Human and Mechanical Error	
HUMAN	MACHINE
<ul style="list-style-type: none"> • Memory lapse • Error of omission <ul style="list-style-type: none"> – Failure to act, or delay in actions – Incorrect actions • Unintended results from taken actions, or “slip-ups” • Lack of knowledge • Lack of experience • “Fear Factor” 	<ul style="list-style-type: none"> • Level of reliability • Errors in programming • Vulnerability to Viruses • Reaction to false stimuli • Susceptible to power outages • Incompatibilities leading to incorrect translation of data

TABLE 8. SOURCES OF HUMAN AND MECHANICAL ERROR.

3.4.3. Command and Control Considerations

The strengths of humans and machines can be allocated to the four phases within Boyd’s OODA Loop, as shown in [Table 9](#). What is noticeable immediately is the great versatility of humans in the “Decide” category, and the greater range of strengths for machines in the “Act” category. These qualities do not imply that humans or machines are preferred for any single phase of this Command and Control methodology. Any

sophisticated system is likely to need a dynamic combination of human and mechanical input for a wide variety of stimuli, processes, and actions.

	Human Strength	Machine Strength
Observe	<ul style="list-style-type: none"> • Detection of certain forms of very low energy levels • Sensitivity to an extremely wide variety of stimuli • Perceiving patterns and making generalizations about them 	<ul style="list-style-type: none"> • Monitoring (both men and machines) • Sensitivity to stimuli beyond the range of human sensitivity (infrared, radio waves.) • Insensitivity to extraneous factors
Orient	<ul style="list-style-type: none"> • Ability to store large amounts of information for long periods - and recalling relevant facts at appropriate moments • Ability to continue to perform when overloaded 	<ul style="list-style-type: none"> • Storing and recalling large amounts of information in short time-periods • Performing complex and rapid computation with high accuracy
Decide	<ul style="list-style-type: none"> • Ability to exercise judgment where events cannot be completely defined • Ability to react to unexpected low-probability events • Applying originality in solving problems: i.e., alternative solutions • Ability to profit from experience and alter course of action • Ability to reason inductively 	<ul style="list-style-type: none"> • Deductive processes
Act	<ul style="list-style-type: none"> • Improvising and adopting flexible procedures • Ability to perform fine manipulations, especially where misalignment appears unexpected 	<ul style="list-style-type: none"> • Performing routine, repetitive, or very precise operations • Responding very quickly to control signals • Doing many different things at one time • Exerting large amounts of force smoothly and precisely • Ability to repeat operations very rapidly, continuously, and precisely the same way over a long period • Operating in environments which are hostile to man or beyond human tolerance

TABLE 9. STRENGTHS OF HUMANS AND MACHINES RELATED TO BOYD'S OODA LOOP.

3.4.4. Functional Performance Role Allocation

H.E. Price proposed a simple methodology to determine whether a function should be allocated to a human or to a machine.⁴⁸ Functions are scaled in his model, shown in [Figure 20](#), based on the each of their levels of performance, rated from Unsatisfactory to Excellent, and plotted on a simple two-dimensional axis. This model is highly reliant on the judgment of the decision maker, and on consistent decisions between multiple decision makers.

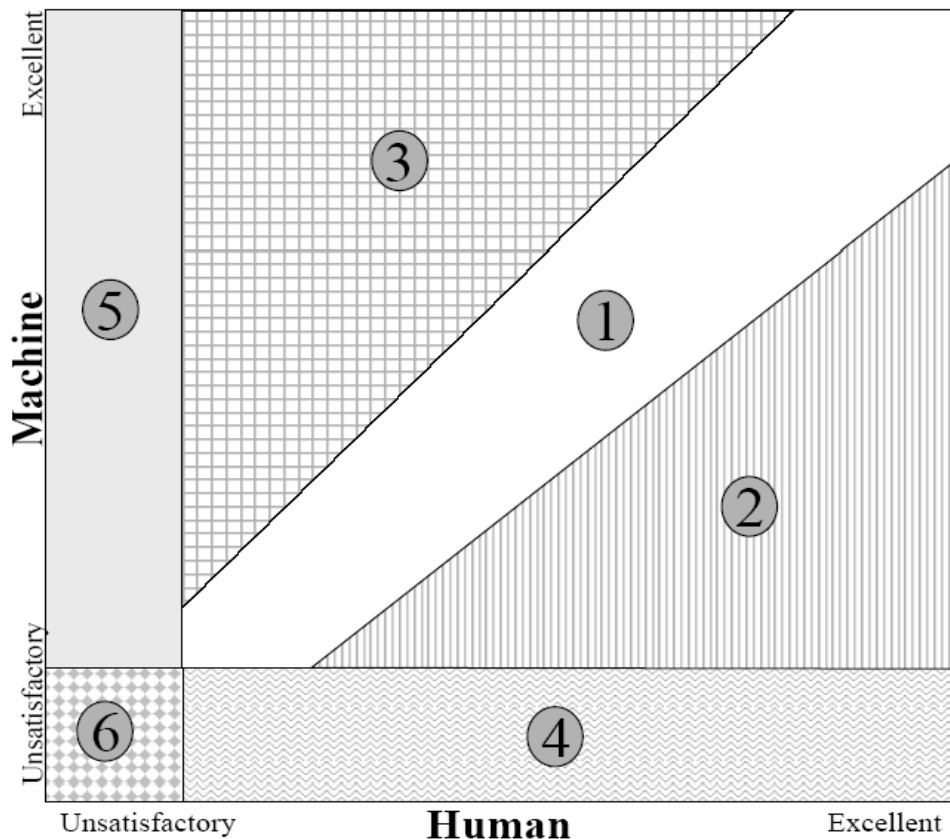

Figure 20. Price's Comparison Methodology for Allocating Roles to Humans or Machines⁴⁹

⁴⁸ Price, H. E. The Allocation of Functions in Systems. Human Factors. Vol 27, No. 1.1985. p. 33-45.

⁴⁹ Price, H. E. The Allocation of Functions in Systems. Human Factors. Vol 27, No. 1.1985. p. 33-45.

Below is a description of the generalized relationships that are mapped on Price's Scale:

1. Little difference in human and machine; choice made on the basis of criteria other than relative performance.
2. Human performance exceeds machine performance; the decision should be made by the human.
3. Machine exceeds human performance; decision should be made by the machine.
4. Poor Machine performance; decision should be allocated to humans.
5. Poor Human performance; decision should be allocated to machine.
6. Unacceptable for both human and machine, arguing for a different design approach.

3.4.5. Current Decision Methodology

There is no definitive accepted process in determining whether or not a mission should be completed by a manned unit or an unmanned unit. [Figure 21](#) shows a process currently used to make this decision. This process was provided by the office of OPNAV N812D.⁵⁰

⁵⁰ Email from CDR Edward J. McDonald OPNAV N812D, Integration Pentagon, Room 4D453 (703) 614-0280 DSN 224-0280 edward.j.mcdonald@navy.mil Mon 3/8/2010 6:38 AM

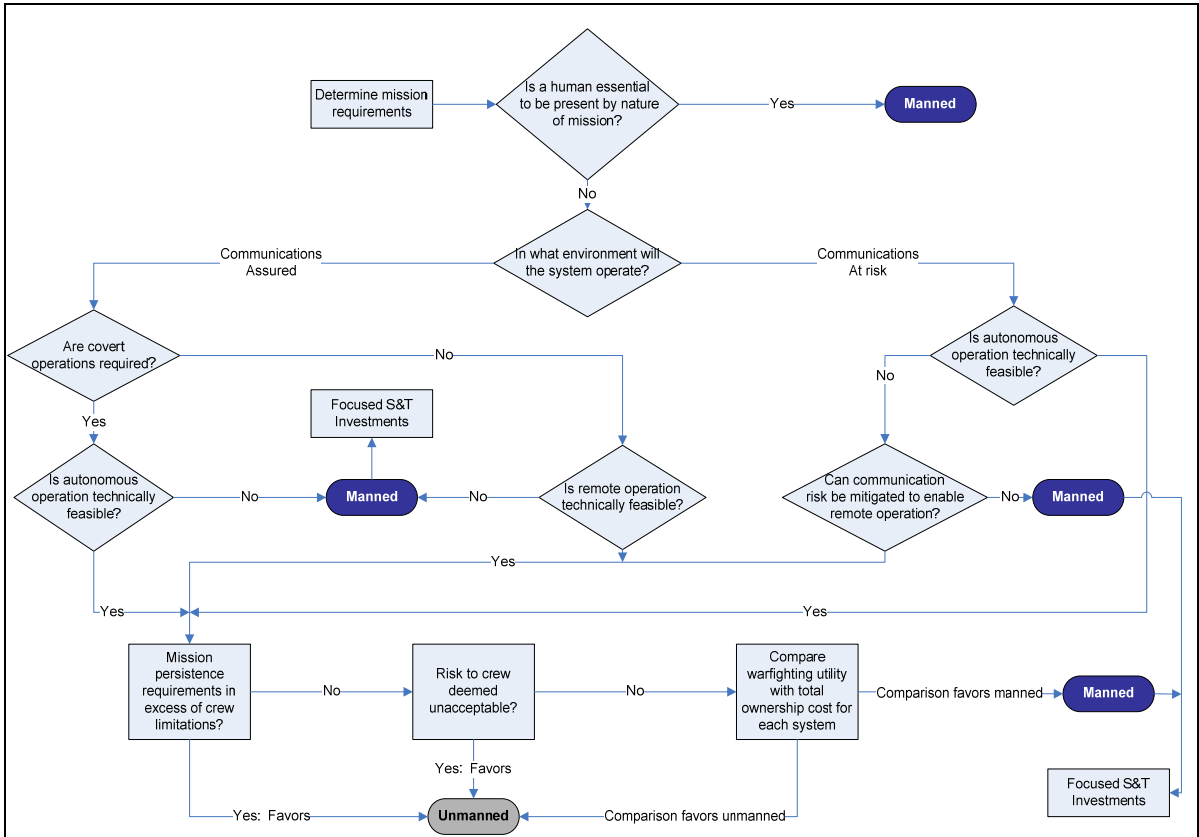

Figure 21. Example of Current UMS System Decision Tree⁵¹

This decision process requires the decision maker to make choices based on several general themes. Ultimately, costs are a major constraint that will need to be analyzed after major functional drivers are evaluated.

In future integrated vehicle architecture, differing levels of autonomy based on the ALFUS framework will be required at each node in the system. All systems will have varying degrees of autonomy.

⁵¹ Email from CDR Edward J. McDonald OPNAV N812D, Integration Pentagon, Room 4D453 (703) 614-0280 DSN 224-0280 edward.j.mcdonald@navy.mil Mon 3/8/2010 6:38 AM

3.4.6. Human Machine Collaborative Decision Making (HMCDM)

The designs of systems where humans and machines collaborate have been modeled after human processes, which are augmented by mechanical capabilities. Malasky asserts that “Future C2 planning systems can be improved if the humans and machines are integrated fully in a way that takes advantage of the strengths of both.”⁵² This HMCDM experiment proposes that collaboration should be designed from the beginning of the decision making process, and demonstrated the potential for improvement in the quality and speed of solutions to a military planning problem.⁵³

When humans and machines are capable of collaborative decision making, the question still remains, “Who is in charge?” If a human operator is designated to have overarching authority, then the capability for a machine to override the human operator must also be considered. This paradigm is illustrated in [Figure 22](#).⁵⁴ Assuming human operator control authority, Region A shows machine recognition that an action was not taken when it should be taking place, and Region B shows the recognition by the machine of inappropriate actions being taken by the human. Recognizing these possible results, the decision maker must choose whether or not to allow mechanical intervention, and whether human operators should still have the ability to override the corrective action based on human factors of interpretation.

⁵² Malasky, Jeremy S. Human Machine Collaborative Decision Making in a Complex Optimization System. 12 May 2005. p. 146.

⁵³ Malasky, Jeremy S. Human Machine Collaborative Decision Making in a Complex Optimization System. 12 May 2005. p. 145.

⁵⁴ Inagaki, T. Human-Machine Collaboration for Safety and Comfort. Presented to ENRI International Workshop on ATM/CNS. 2009. 3.

		Human's control action		
		Action needed in the situation	Action allowed in the situation	Action not appropriate in the situation
Computer's judgment	"Action is detected"			B
	"Action is not detected"	A		

Figure 22. Human Control vs. Computer Judgment⁵⁵

⁵⁵ Inagaki, T. Human-Machine Collaboration for Safety and Comfort. Presented to ENRI International Workshop on ATM/CNS. 2009. 3.

3.5. INFORMATION ASSURANCE CONSIDERATIONS FOR C2 ARCHITECTURE

The confidentiality, integrity, and timely availability of information is enabled by encryption, frequency shifting and system redundancies often play an important part in the success of military operations. This section seeks to find ways to safeguard information assets by examining problems from an information assurance perspective.

3.5.1. Identity and Key Management

Identity management is crucial to any large scale organization in managing the effectively accesses of individuals to its resources. The conventional identity management concept deals with managing the identities of individuals in a system. In an Unmanned Vehicle (UV) scenario, the individuals dealt with are no longer humans. The scope of identity management will thus have to be extended beyond human subjects.

One of the most important requirements for identity management is to identify a subject uniquely. For human subjects, the focus was on “what we are” (e.g. biometrics such as fingerprint or facial features), “what we have” (e.g. tokens such as smart card) and “what we know (e.g. password) to uniquely identify an individual. For UVs, the simplest implantation would probably have to be in the form of a “secret” that only the UV knows. The system would have to trust that once a UV proved that it has knowledge of a unique “secret”, it is who it claims to be. This “secret” can be in the form of a cryptographic key stored in a tamper proof device embedded inside the UV.

Lifecycle of a UV

A good identity management system would have to take care of the entire lifecycle of the subjects.

A secret key would have to be generated during the production of a UV in a secure manner. This key would have to be unique cryptographically and stored in a tamper proof device in such a manner that any attempts to tamper with the device would result in the destruction of the key. A feasible implementation of such a mechanism would be an asymmetric key pair where the private key is stored inside a tamper-proof

chip embedded inside the UV and the public key is tied to the identity of the UV in a central identity management database in the system.

Just like a clearance level is given to each human individual, each UV may be given a clearance level (unclassified, secret, top secret) that identifies the information that they are allowed to access. An alternative implementation would be a role-based mechanism where each UV is assigned a specific role and the resources are tied to the role that they are assigned to. The UV may switch to a number of different roles throughout its lifecycle and the system must be designed to accommodate this change.

A common database scheme would have to be established to allow different types of unmanned vehicles to be enrolled into an enterprise wide identity management system and for keeping track of all the keys embedded inside each unmanned vehicle. A separate key management system and Public Key Infrastructure might be necessary to support the deployment and management of keys to the unmanned vehicles.

Once a UV is retired, destroyed, compromised, or transferred out of the system, the identity management system would have to terminate its associated account and privileges to make sure no other individual is able to make use of that identity to gain unauthorized access to the system.

3.5.2. High Assurance Internetworking

The goal of high assurance internetworking is to protect the confidentiality, integrity and availability (CIA) of information while in transit across the network. At the same time, attacks against the network have to be identified and blocked. Cryptography (Encryption, hashing and digital signatures) is used to provide the protection of the data as it transits the network while traffic filtering (firewalls, intrusion detection) is used to protect the network against attacks.

The amount of protection required for various data types is identified and tabulated in OV3. The following factors were considered:

- Confidentiality The confidentiality of data is usually protected by performing encryption. However, performing encryption on large amounts of data can cripple the performance of the system. As such, data such as live video feed would not be encrypted.
- Integrity The integrity of the data can be provided by performing hashing on the data along with digital signatures. Control data sent to UVs need to have high integrity to prevent aggressors from hijacking the UVs.
- Availability Availability can be provided by introducing redundancies in the system. The level of availability required in the system is decided by the criticality and timeliness requirements of the system.

Additional features could be implemented in the system to improvement the assurance of the network. The security data from diverse sources across the networks can be aggregated and normalized to provide a holistic view of the network health and status. A business intelligence framework could also be utilized to maximize the usefulness of historical and near real-time network defense data. Capabilities could be developed to detect non-traditional forms of network intrusion. In addition, some form of visualization could also be implemented to provide better awareness of the network topology and detected intrusions.⁵⁶

3.5.3. Tamper-Proof Device

There are two aspects of tamper proof devices. A tamper-evident device provides a lower level of security than a tamper-resistant device since the former only detects evidence of unauthorized access to the protected device while the latter prevents

⁵⁶ Network Security Section, <http://www.nrl.navy.mil/chacs/5544/>.

unauthorized access of the protected device. Having a tamper-resistant device is more relevant than having a tamper-evident device for the UMS in this architecture.

The two scenarios in this project, reconnaissance and force protection, require extensive data collection as part of the operation. It is important that the storage device be tamper-resistant. Requirements for tamper-resistant storage within the UMS are:

- Weight of device – lightweight is preferred as additional increase in weight affects the payload of the unmanned vehicles
- Power consumption – unmanned vehicles can only operate as long as their batteries allow, so additional increase in power consumption will reduce the operating time of the unmanned vehicles
- Data storage space – having a large data storage space means able to collect more data for analyzed.
- Robustness – device must not fail under harsh environment conditions
- Authenticity guarantees – ensuring authorized access to the device
- Confidentiality guarantees – ensuring data in the device are not able to be viewed by unauthorized access
- Integrity guarantees – ensuring that data in the device are not modified
- Performance overhead to security – having an enhanced encryption algorithm requires more computation power which adds on to the power consumption of the device. On the other hand, having a basic, simple encryption algorithm may lower the security level of the device

While there are ready tamper-resistant secure storage devices available commercially, there are still some research challenges for tamper-resistant devices. They are:

- Protect Confidentiality of information - looking at enhanced methods to prevent unauthorized users from viewing data and exploring reverse-engineering protection mechanism
- Protect Functional Integrity - ensure device performs its intended function and does not allow device to be tampered, and enhancement of secure processors architecture
- Protection against unauthorized copying or modification - verification methods to check valid changes of new versions of data
- Authenticity guarantees - establishing and maintaining origin of data as well as exploring methods to associate signatures with data and establishing versioning for data fragments
- Scalability - able to handle/manage large size file system, number of users, number of processes; design small form factor devices and yet support expansion (scalability)
- Performance overhead - techniques for lowering performance overheads for cryptography ciphers; design enhanced ciphers to include parallelism

Optimistically, some of these challenges can be addressed with technological advancements in the coming future. More importantly, having tamper-resistant secure storage to be implemented in unmanned vehicles is a small step towards information operational assurance of the system.⁵⁷

⁵⁷ Elizabeth Haubert Joseph , Joseph Tucek , Larry Brumbaugh , William Yurcik, “Tamper-Resistant Storage Techniques for Multimedia Systems,” In *IS&T/SPIE International Symposium Electronic Imaging / Storage and Retrieval Methods and Applications for Multimedia*. 2005.

3.5.4. Availability and Denial of Service

The UVs will operate in a rich collaborative information environment that is potentially hostile. Hardware failures, resource exhaustion, environmental conditions, or any complicated interaction between these factors can affect the availability of the system. The adversary may launch denial of service attacks by manipulating the environment so as to disrupt communication, for example by jamming our communications from a distance or putting themselves in the networks and disrupting infrastructure functions and lines of communications, such as routing of messages performed by the individual nodes. In addition, the communications infrastructure may be unable to handle the heavy demands where many messages are routed for synchronization of activities, sharing of information and collaboration. The impact is degradation in situational awareness and defense capabilities in both scenarios.

The architecture should be resilient against noise and provide robust anti-jamming capabilities to defeat jamming attacks. In addition, solutions must be developed to authenticate nodes and defend against resource exhaustion, flooding attacks to waste bandwidth and energy, traffic redirections and other forms of denial of service attacks. Factors such as frequency allocation, radiated power, battery life, and organizational lines of communications should also be analyzed.

Assuming large scale deployment of cheap nodes, the network should be resilient to individual node failure as a node may fail at any time. Node failure may be due to hardware or software failure, end of battery life, compromised or destroyed by the adversary. The architecture should allow new nodes to be added to the network to replace a failed node. New nodes may also be introduced to enhance system performance, e.g. to increase the operating range. These nodes should be integrated seamlessly into the existing network without impacting overall performance.

The adversary may intercept and subvert a node in the network or introduce their own nodes to disrupt our operations. Strong authentication and tamper-proof technologies must be developed to increase the assurance that a node has not been compromised and that it has been authorized to participate in the network. These

mechanisms must be economical and must take into account the overall payload and battery life that the UVs can support. Messages should also be authenticated without introducing too much overhead and slowing down the operation to unacceptable levels.

The ability to detect and react against a denial of service attack is critical to the availability of assets. The architecture should at least provide the means to report the incident of an attack to the operator for man-in-the loop intervention. Development of self-healing capabilities will further improve service availability by discovering, diagnosing, and reacting autonomously to network disruptions. Self-healing components will detect system malfunctions (accidental or deliberate) and start corrective actions based on defined policies to recover the network or a node, thus automatically recovering from damages. Algorithms to be developed include election and activation of backup nodes, re-routing to the next available nodes and coordinating physical re-location of nodes. These algorithms must be as efficient as possible since the UVs will have low processing power, even though it was expected that hardware processing power to increase tremendously by 2030.

3.6. ENGINEERING ASSESSMENT OF CAPABILITIES UNMANNED SYSTEMS: ENGINEERING FOR 2030

3.6.1. Introduction

Current trends of sustainable energy, “greener” emission friendly energy resources and overall efficiency as a financial driver can be seen through a majority of civilian and military projects. It would come to no surprise that the military will help lead the way in ground-breaking research and application of new technologies.

Trade studies were conducted to explore the technology area’s most beneficial to unmanned systems. Specifically, engine cycle efficiency, advanced fuels, and fuel cell/battery power systems were studied. The trade study emphasized maximizing a specific unmanned systems’ ability to stay on station (longer endurance).

3.6.2. Fuel Cycle Efficiency

3.6.2.1. *Internal Combustion Engines*

With perhaps the lowest of cycle efficiencies, internal combustion engines still have a stake in military platforms. The MQ-1 Predator, runs off of a turbo-charged ROTAX 912 four stroke engine. With an average efficiency of 25% (broadly speaking), the internal combustion engine, described by the Otto cycle, can be improved by improving internal combustion efficiency (expected to reach levels as high as 40%, 15% higher than current designs). The technology driving these high efficiency gains can be found in ground-breaking engine designs.

The most publicized engineering success in the area has been the Scuderi Split Cycle Engine. While the split-cycle design has been around since 1914, it has been plagued by low volumetric efficiency and low thermal efficiency.⁵⁸ The Scuderi Group has solved the “breathing” problem of volumetric efficiency on the compression side by reducing the clearance between the piston and the cylinder head to less than 1 mm.⁵⁹ The

⁵⁸ Scuderi Engine, “Why is the Scuderi Split Cycle Engine Better?” <http://www.scuderiengine.com/> (accessed April 23, 2010).

⁵⁹ Ibid.

design alteration described, effectively pushes almost 100 percent of the compressed air from the compression cylinder into the crossover passage, eliminating the breathing problems associated with previous split-cycle engines.⁶⁰

With regard to thermal efficiency, the split-cycle has to date been significantly worse than in a conventional Otto cycle engine because previous designs maintained firing before top-dead-centre (BTDC) - like a conventional engine. In order to fire BTDC in a split-cycle engine, the compressed air trapped in the crossover passage is allowed to expand into the power cylinder as the power piston travels upwards.⁶¹ However, by releasing the pressure of the compressed air, the work done on the air in the compression cylinder is lost. The power piston then has to recompress the air in order to fire BTDC. In a conventional engine, the work of compression is done only once, leading to much better thermal efficiency.⁶² In Scuderi's design, the thermal efficiency problem has been solved by breaking from conventional design best practice and instead firing after top-dead-centre (ATDC). Firing ATDC in a split-cycle arrangement eliminates the losses resulting from recompressing the gas.⁶³

Aside from split-cycle design, additional improvements to the internal combustion engine are emerging. Radical designs such as the 5-stroke engine are predicting efficiency increases up to 20%, and allowing for internal combustion engines to match that of current highly efficient diesel engines. One engineering firm, Ilmor, has brought this invention to light by introducing a 5-stroke engine prototype as a plausible and working engineering design. According to Ilmor, the 5-stroke concept engine utilizes two high-pressure fired cylinders operating on a conventional 4-stroke cycle that alternately exhaust into a central low-pressure expansion cylinder, whereupon the burnt gases perform further work. The low-pressure cylinder decouples the expansion and

⁶⁰ Ibid.

⁶¹ Ibid.

⁶² Ibid.

⁶³ Ibid.

compression processes and enables the optimum expansion ratio to be selected independently of the compression ratio; leading to increased efficiency.⁶⁴

3.6.2.2. Diesel Engines

One of the most surprising driving forces in more efficient engine cycles is coming from Washington D.C. The passing of the U.S. EPA 2010 Emissions Standards has greatly accelerated advancements in diesel technology. The EPA emissions standards pose a significant challenge for developing clean diesel power-trains that are affordable. Along with exhaust emissions, an emphasis on heavy-duty vehicle fuel efficiency is being driven by increased energy costs as well as the potential regulation of greenhouse gases.⁶⁵ With the standards setting strict requirements on minimum engine efficiency, companies such as Cummins Diesel have begin designing and implementing several measures to improve their diesel engines. Three areas of emphasis that lead to substantial improvements in engine thermal efficiency are the maximization of the engine closed cycle efficiency, the reduction of open cycle losses and engine parasitics, and the integration of Highly Efficient Clean Combustion (HECC) engine technology with after treatment.⁶⁶ Emphasis on areas highlighted by Cummins Diesel can lead to future diesel efficiency upwards of 65% by the year 2030.

This focused attention on diesel engines will not just allow for more efficient long-haul truck and tractor applications, but could possibly have ties to future military systems. While diesel engines are not the preferred propulsion system for unmanned air vehicles, they could have significant implications for future unmanned surface vessels and underwater vehicles.

⁶⁴ Ilmor Engineering, "The 5-Stroke Concept Engine," http://www.ilmor.co.uk/concept_5-stroke_1.php (accessed April 22, 2010)

⁶⁵ Energy Efficiency and Renewable Energy Office "Advanced Combustion Engine Research and Development 2009" (paper presented at the annual progress meeting for the U.S. Department of Energy, Washington D.C., December 2009).

⁶⁶Ibid

3.6.2.3. *Gas Turbines*

Gas turbine cycles currently serve as one of the military's prime movers. From naval surface ships, to unmanned Global-Hawk aerial surveillance platforms, gas turbines have a significant stake in propulsion. Much like the advancements of internal combustion and diesel engine cycles, the gas turbine will be able to become more efficient over the next two decades. For efficiency increase to occur, the gas turbine needs to be examined in its most simple representation; the Brayton cycle. For gas turbines, the Brayton cycle can be analyzed as simple or combined.

Simple and combined gas turbine cycle diagrams are shown in [Figure 23](#) below. The Brayton cycle can be characterized by two important parameters: pressure ratio and inlet temperature. The pressure ratio of the cycle can be described as the compressor discharge pressure divided by compressor inlet pressure.⁶⁷ However, in an actual cycle there is some slight pressure loss in the combustion system and thus the pressure at the combustor discharge is less than the combustor inlet. The other significant parameter, turbine inlet temperature, is thought to be the highest temperature reached in the cycle.

⁶⁷ Frank Brooks, "GE Gas Turbine Performance Characteristics," *GE Power Systems- GER3567H*

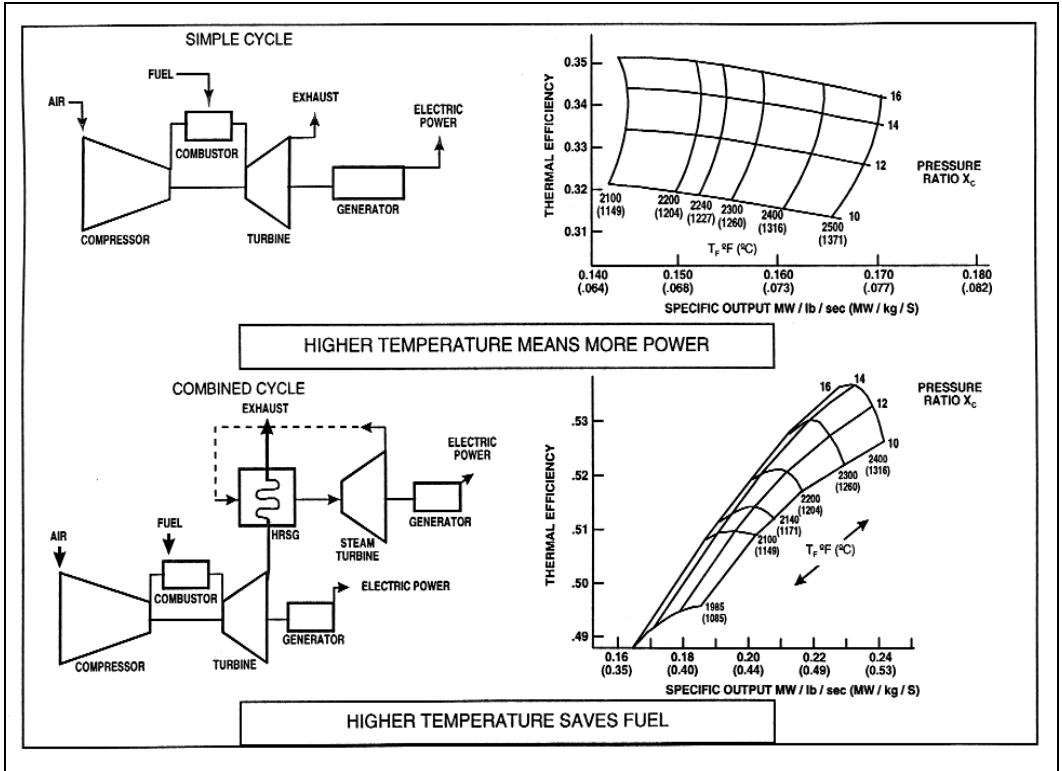

Figure 23. Comparison of Simple & Combined Cycles⁶⁸

⁶⁸ Ibid.

In simple-cycle applications (the top curve), pressure ratio increases translate into efficiency gains at a given inlet temperature. However, for combined-cycle systems, as shown in the bottom of [Figure 23](#), pressure ratio increases have a less pronounced effect on efficiency.⁶⁹ Note also that as pressure ratio increases, specific power decreases. Increases in the turbine inlet temperature result in increased thermal efficiency. Simple-cycle efficiency is achieved with high pressure ratios. Combined-cycle efficiency is obtained with more modest pressure ratios and greater firing temperatures.

3.6.2.4. Pulse Detonation Engines (PDEs)

Still in development, pulse detonation engine technology is being pursued as the means to achieve more efficient high-speed flight. PDEs offer an alternative source of propulsion to current turbojet and ramjet/scramjet systems, by incorporating nearly constant volume combustion vice constant pressure combustion, which governs Brayton cycle operations.⁷⁰ The cycle is shown in [Figure 24](#). In a PDE, the combustion chamber is filled with a fuel/air mixture and detonated. A detonation wave propagates through the chamber creating high pressures that produce thrust.⁷¹ Products of combustion are exhausted and the cycle starts again. Either running this cycle at high frequencies or coordinating multiple combustion chambers can produce quasi-steady thrust.⁷²

⁶⁹ Brooks, Frank., "GE Gas Turbine Performance Characteristics," *GE Power Systems- GER3567H*

⁷⁰ B. Bartosh, "Thrust Measurement of a Split-Path, Valveless Pulse Detonation Engine" (MSME Thesis, Naval Postgraduate School, 2007) 13

⁷¹ Hutchins, T.E. and Metghalchi, M. "*Energy and Exergy Analyses of the Pulse Detonation Engine*" North Eastern University ASME Vol 125. October 2003.

⁷² Ibid.

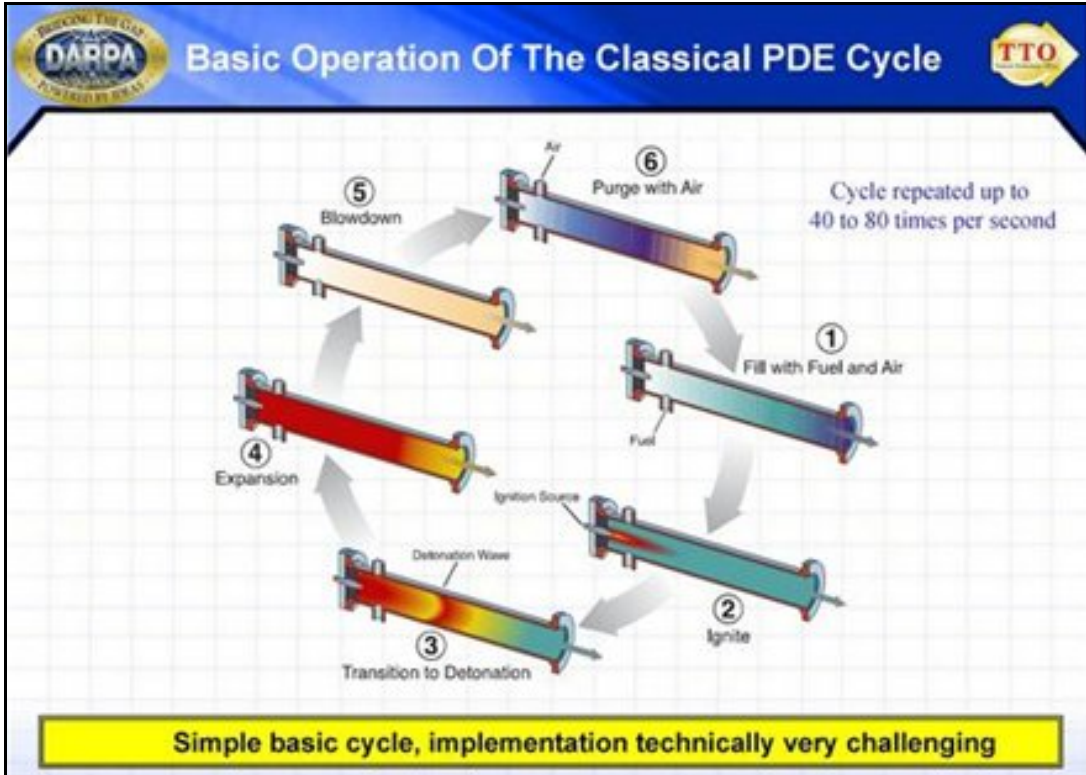

Figure 24. The Pulse Detonation Engine Cycle⁷³

This type of combustion produces two beneficial results, higher temperature increase and higher pressure. The higher combustion pressures (compared to Brayton Cycle), and a lower entropy rise, result in a total enthalpy increase; thus allowing for efficiency increases of 25-35% over typical Brayton cycles.⁷⁴ Overall PDE cycle efficiency is estimated to be as high as 55% by 2030. [Figure 25.](#), shows the comparison of the Brayton cycle to the Humphrey cycle, which best models pulse detonation engine systems.

⁷³ Ibid.

⁷⁴ Bartosh, B., "Thrust Measurement of a Split-Path, Valveless Pulse Detonation Engine" (MSME Thesis, Naval Postgraduate School, 2007) 13

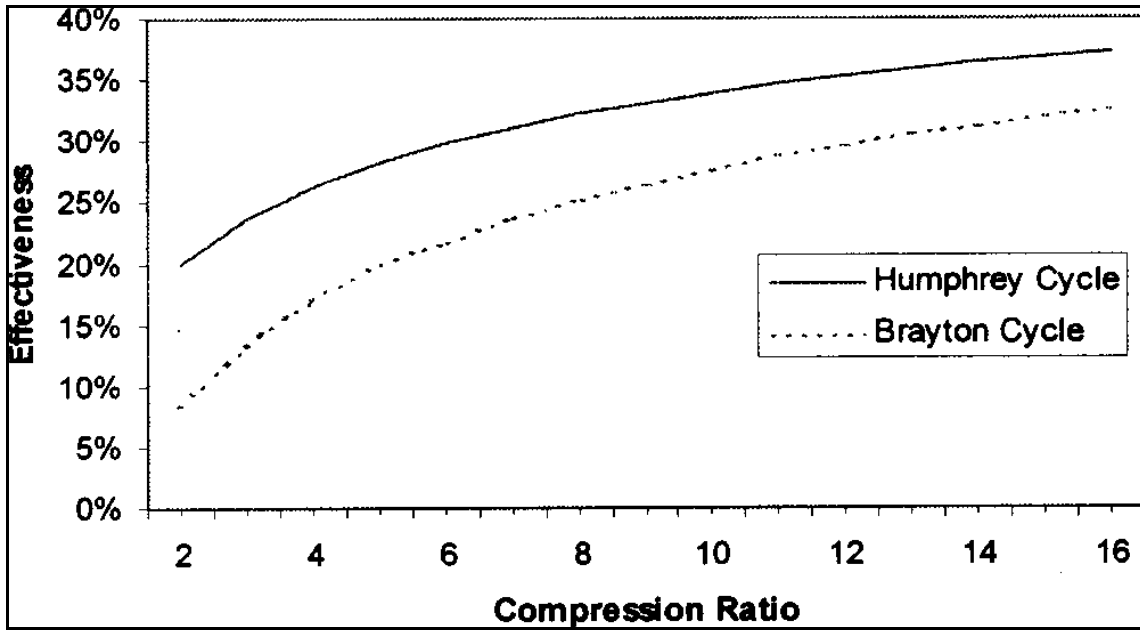

Figure 25. Comparison of Humphrey and Brayton Cycles⁷⁵

Currently, the application of PDE technology is more suited for cruise missile type platforms, but further advancements and design of unmanned platforms could see the application of PDE to the design of unmanned systems.

3.6.2.5. *Constant-Volume-Combustion (CVC) Hybrid Engines*

The Defense Advanced Research Projects Agency (DARPA) has invested resources in a program focused on combined-cycle propulsion system architecture, with separate CVC and turbine engines, intended for high-Mach military aircraft.⁷⁶ This program, titled “Vulcan,” is one of the most specific applications of the CVC concept. The “Vulcan” is the combination of a turbojet and a CVC process. Constant volume combustion technology can be integrated into a turbine engines through many different architectures – a combined-cycle propulsion system with a separate CVC engine and a turbine engine sharing a common inlet and common nozzle; CVC engine integrated into a

⁷⁵ Ibid.

⁷⁶ “Constant Volume Combustion (CVC) Technology for Vulcan Program Phase II” Solicitation Number: DARPA-SN-09-70 <https://www.fbo.gov/index?s=opportunity&mode=form&id=31f9542e9eaf99222a1bb41c12a692a4&tab=core&cvview=1>

turbine engine fan duct; CVC engine integrated into a turbine engine augmentor; and a hybrid system, where a turbine engine combustor is replaced with a CVC module.⁷⁷ All of the aforementioned architectures greatly improves the performance and increases the capability of turbine engines.

Constant volume combustion systems have the potential to significantly decrease the fuel consumption of U.S. Navy air and surface combatants (manned and unmanned platform) and provide increased capability.⁷⁸ Specifically for naval surface applications, the CVC-hybrid engine will be smaller in terms of output and size relative to the propulsion turbine units, but the ship power turbine units will consume only half the fuel originally required.⁷⁹ Capabilities of U.S. Navy surface vessels continue to grow due to the need to incorporate more capable and numerous defensive and offensive systems to address new threats and missions; replacing conventional combustors and integration of CVC into the power generation gas turbines on these vessels promises additional ship electrical power and lower Specific Fuel Consumption (SFC).⁸⁰

3.6.2.6. Forecast of Cycle Efficiency Increases

The focus of the above trade study was to gather information to best extrapolate the efficiencies of several different engine cycles involved with military platforms. In order to best predict the future, current technology needed to be established as a reference point. [Figure 26](#). shows the average efficiency of all the previously mentioned engine cycles over the next two decades. The efficiencies displayed in the plot are forecasts of potential capabilities.

⁷⁷ Ibid.

⁷⁸ Ibid.

⁷⁹ Warwick, Graham “DARPA Lifts the Covers on the Vulcan Engine Program” posted June 6, 2008, <http://www.aviationweek.com/aw/blogs/defense/index.jsp> (accessed May , 2010).

⁸⁰ Ibid.

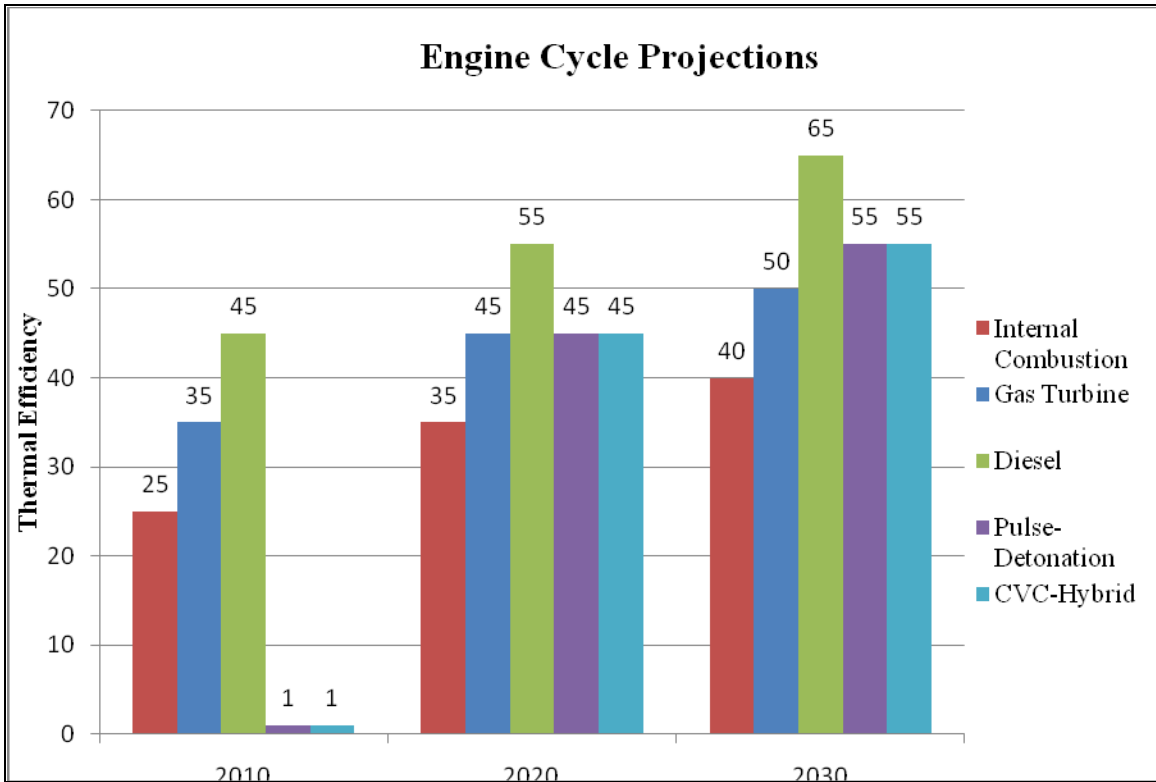

Figure 26. Extrapolation of Engine Cycle Efficiency

3.6.3. Advanced Fuel Technology

The area of fuel research contains avenues that can have significant impacts on military platforms. From current distillate fuels to “greener” bio-fuel products and advanced synthetic fuels, there exists potential for increased performance directly from fuel sources.

3.6.3.1. Distillate Fuel

Distillate fuel can be more commonly described as fuels that are petroleum derived. Over the past one hundred years, petroleum based fuels have been refined and produced to yield more efficiency and cleaner by-products. One of the most measurable figures for fuels is the Net Heat of Combustion (by mass or volume). The table below is tabulated for three different U.S. military jet fuels:

Fuel Type	Year Introduced	Net Heat of Combustion By Weight (kJ/kg)	Net Heat of Combustion By Volume (MJ/m ³)	Service
JP-4	1951.0	43570	33190	U.S. Air Force Fuel
JP-5	1952.0	43050	35200	U.S. Navy Fuel
JP-8	1979.0	43240	35060	U.S. Air Force Fuel
JP-10	1993.0	42100	39582	U.S. Navy Fuel

TABLE 10. U.S. MILITARY JET FUEL LOOP.

From [Table 10](#), it can be seen that for the past 50 years, there is not significant or any improvement in terms of Net Heat of Combustion by Weight or by Volume. With even this brief snapshot of fuels, it can be concluded that any improvement from distillate fuel will most likely be insignificant.

3.6.3.2. Bio-Fuel

With an ever-increasing reliance on petroleum-based fuels, there is a need to find an alternative to petroleum in order to reduce the dependency on foreign oil. Figure below shows the projected reliance on petroleum imports:

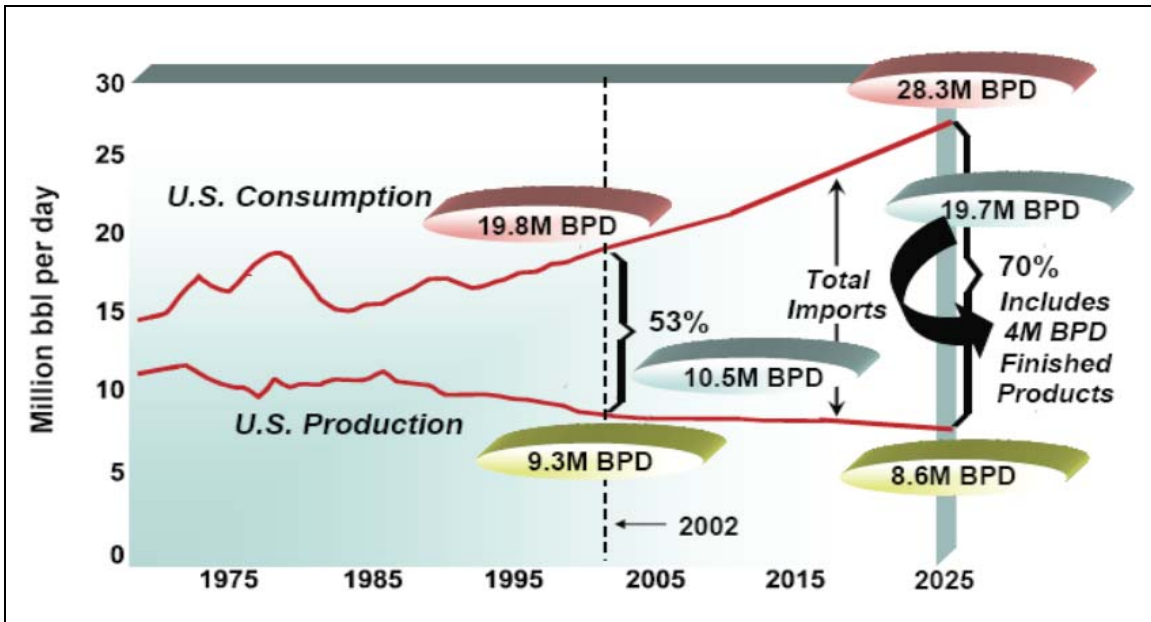

Figure 27. Projected U.S. Reliance on Petroleum Imports⁸¹

With such dependency on petroleum imports and fluctuating fuel costs, Defense Advanced Research Project Agency (DARPA) released a solicitation calling for alternatives to aviation fuel. This analysis is shown in [Figure 27](#). This solicitation has already lead to successful test of Syntroleum, a 50-50 blend of synthetic and JP-8 fuel with Air Force B-52's in flight. This fuel is synthetic kerosene produced from natural gas through the Fischer-Tropsch (F-T) process.⁸² Additionally, the U.S. Navy celebrated Earth Day April 22, 2010 by showcasing a flight test of the "Green Hornet," an F/A-18 Super Hornet multirole fighter jet powered by a bio-fuel blend.⁸³ The Green Hornet runs on a 50/50 blend of conventional jet fuel and a bio-fuel that comes from camelina, a hardy U.S.-grown plant that can thrive even in difficult soil.⁸⁴

⁸¹

⁸² Zamorano, Marti, "B-52 synthetic fuel testing: Center commander pilots first Air Force B-52 flight using solely synthetic fuel blend in all eight engines", *Aerotech News and Review*, 2006-12-22

⁸³ Navy Tests Biofuel-Powered 'Green Hornet', http://www.navy.mil/search/display.asp?story_id=52768 April 22, 2010.

⁸⁴ Ibid.

The use of non-renewable fossil fuels to provide jet fuel should be seen only as a means to an inevitable end. It is possible that bio-fuel alternatives together with (F-T) produced synthetic kerosene could offer a potential long-term renewable solution to U.S. fuel vulnerabilities. Therefore it is only foreseeable that U.S. will be moving towards bio-fuel in the near future. [Table 11](#) below shows the properties of bio-fuel as compared to traditional petroleum derived jet fuel:

Fuel	Specific Energy MJ/Kg	Energy Density MJ/l	Boiling Point °C	Freezing Point	Viscosity
Jet Fuel	43.2	34.9	150 - 300	<-40	1.2
Biodiesel	38.9	33.9	>400	0	4.7
Ethanol	27.2	21.6	78	-183	1.52
Butanol	36.0	29.2	118	-89	3.64

TABLE 11. BIO-FUEL TO JET FUEL COMPARISON.

As seen in [Table 11](#), using bio-fuel there will yield a significant drop in energy content as compared to distillate jet fuels currently in use. Thus, there is a high possibility that fuel alone will not be the sole factor that can be used to improve endurance for Unmanned Vehicles.

3.6.3.3. Future of Fuel Technology

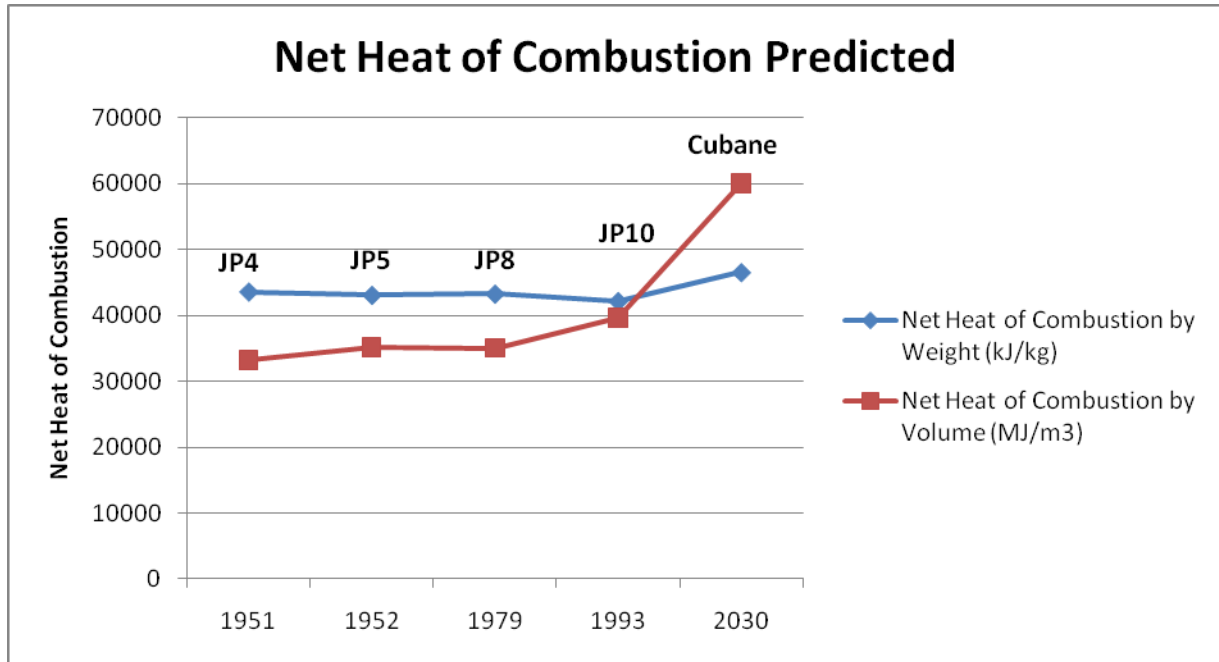

Figure 28. Prediction of Energy Content of Future Fuel

Advanced fuel technology offers the best application for increased performance in the arena of synthetically derived fuels. One such currently being explored, High Energy Density Material (HEDM) is a material that might be used as the fuel for the future. Due to its high energy numbers, Cubane is 71% higher in terms of Net Heat of combustion by volume, which makes it a good candidate for improving endurance for Unmanned Vehicles. At the moment, Cubane is not only expensive to synthesize, but is also extremely time consuming for a material expected to be used in large quantities. The results are shown in [Figure 28](#).

3.6.4. Battery Technology

3.6.4.1. Current Battery Technology

Throughout the last decade batteries have evolved to power electric vehicles. The demand for cleaner fuel, longer endurance and minimal cost has caused this field of research and development to grow at an exponential rate. The three major battery technologies leading this field are Lead-acid, Nickel Metal Hydride (Ni-MH) and

Lithium-ion Battery. Research in the field of Lead acid batteries is nearing an end due to their large size and reputation of being environmentally unfriendly. See [Table 12](#) below, for comparison among the three battery technologies⁸⁵.

Lithium-ion Batteries has become the way of the future because of its high energy density and long life cycle. Further research and development into Lithium-Ion batteries will be discussed later.

Items	Li-ion	Ni-MH	Lead-acid
Working voltage (V)	3.7	1.2	2.0
Gravimetric energy density (Wh/kg)	130~200	60~90	30~40
Volumetric energy density (Wh/L)	340~400	200~250	130~180
Cycle life (cycles)	500	400	300
Capacity self discharge rate (% per month)	5%	30%	10%
Memory effect	None	40%	None
Energy efficiency ($C_{\text{discharge}}/C_{\text{charge}}$)	99%	70%	75%
Weight comparison for the same capacity	1	2	4
Size comparison for the same capacity	1	1.8	3.5
Reliability	High	Low	High

TABLE 12. BATTERY TECHNOLOGY COMPARISON.⁸⁶

3.6.4.2. *Lithium-Ion*

As noticed in the above chart it is clear why Lithium-Ion batteries and its research are in the forefront for future use in electric and hybrid technology. As seen in the chart, lithium batteries have a higher energy density, higher working voltage and life cycle than that of Ni-MH and lead-acid batteries.

However, the true selling point of Lithium-Ion lies in its more practical advantages⁸⁷:

⁸⁵ General Electric, <http://ge.geglobalresearch.com/>

⁸⁶ Ibid

⁸⁷ Ibid

- Efficiently fit most devices due to various shapes and sizes.
- Lighter weight.
- Power transferred at a lower rate of current.
- No memory effect.
- Self-discharge rate of approximately 5-10% per month.

3.6.4.3. *Lithium Iron Phosphate LiFePO4*

Lithium Iron Phosphate is a variation in the chemistry of lithium ion batteries. General electric Battery company research and development teams have done various field of study into this type of chemistry. They site this chemistry as “becoming the best-choice materials in commercial Li-ion Batteries for large capacity and high power applications.”

Advantages of Lithium Iron Phosphate⁸⁸:

- Larger capacity compared to other chemistry.
- High power applications
- Safe as lead-acid battery
- Comparable power to lithium ion cells at lower cost.

Disadvantages of Lithium Iron Phosphate⁸⁹:

- Cost (production of lithium batteries are still very expensive)
- Specific energy (energy/volume) of a new LFP battery is lower than a new LiCoO₂ battery.
- Many brands of LFP's have a low discharge rate compared with lead-acid or LiCoO₂

⁸⁸ Ibid

⁸⁹ Lithium Iron Phosphate Batteries ,
http://en.wikipedia.org/wiki/Lithium_iron_phosphate_battery#Advantages_and_disadvantages

3.6.4.4. Future Battery Developments

The lithium air battery is an advanced design in which a lithium anode is electrochemically coupled to atmospheric oxygen through an air cathode. During discharge, lithium ions flow from the anode through an electrolyte and combine with oxygen at the cathode (typically consisting of porous carbon) to form lithium oxide Li_2O or lithium peroxide Li_2O_2 , which is inserted in the cathode; this is coupled to the flow of electrons from the battery's anode to the cathode through a load circuit⁹⁰. The advantage of lithium air batteries compared to other technology is the higher density that typical lithium ions batteries because of the lighter cathode.

Another revolutionary battery concept, the “nanowire battery” was invented by a team led by Dr. Yi Cui at Stanford University in 2007. It is made up of a stainless steel anode covered in silicon nanowires, to replace the traditional graphite anode. Since silicon can store up to ten times more lithium than graphite this allows for a greater energy density on the anode and reduces the mass of the battery. This battery has a higher surface area allowing for a faster charging and discharging⁹¹

3.6.5. Fuel Cell Technology

The advantage of fuel cell technology is found in its practical operating basis: converting chemical energy in the fuel into electricity, silently, without explosion or combustion. Fuel cells have a number of advantages over other technologies for power generation. They have the potential to use less fuel than competing technologies and emit no pollution when used. In terms of future applications, fuel cells can provide power for onboard use (sensors, communication, etc) as well as direct drive propulsion to physically move the system. There are also many reasons why a fuel cell might be useful in specific environments, such as the high quality of electricity generated or their quiet operation.⁹²

⁹⁰ Lithium Air Battery, http://en.wikipedia.org/wiki/Lithium_air_battery

⁹¹ Nanowire Battery, http://en.wikipedia.org/wiki/Nanowire_battery

⁹² Fuel Cell Today, “General Fuel Cell Information,” <http://www.fuelcelltoday.com/> (accessed 05 May, 2010).

3.6.5.1. *Polymer Electrolyte Membrane*

One outstanding example is the German Type 212 Howaldtswerke-Deutsche Werft (HDW) submarines. These submarines utilize an air-independent propulsion (AIP) system with polymer electrolyte membrane (PEM) fuel cells developed by Siemens. These fuel cells enclose a solid polymer electrolyte and yield power outputs in the range of 30-40 kW.⁹³ On the anodic side of the proton exchange membrane, hydrogen is decomposed into its protons and electrons. The electrons are then used in the submarine's power supply. The electrons return via the cathode to re-combine with the protons, and together with the oxygen molecules in the air form pure water.⁹⁴

Polymer Electrolyte Membrane fuel cells used in automobiles are called Proton Exchange Membrane fuel cells. Currently, the car industry is the most promising industry that is actively investing and researching in PEM technology. The potential power generated by a fuel cell stack is limited by the number and size of the individual fuel cells that comprise the stack and the surface area of the PEM. Nevertheless, the benefits of PEM are as follows:⁹⁵

- **Minimize Emissions.** Gasoline- and diesel-powered vehicles emit greenhouse gases (GHGs), mostly carbon dioxide (CO₂), that contribute to global climate change. However, PEM only by-product is water.
- **Reduced Oil Dependence.** Hydrogen can be derived from domestic sources, such natural gas and coal, as well as renewable resources such as water. This forms a political and economy protection by being less dependent on other countries and less vulnerable to oil price shocks from the volatile oil market.

⁹³ Peter Hauschildt and Albert Hammerschmidt, “PEM Fuel Cells – An Attractive Energy source for Submarines,” <http://info.industry.siemens.com/data/presse/docs/m1-isfb07033403e.pdf> (accessed 05 May, 2010).

⁹⁴ Ibid.

⁹⁵ Ibid

Besides PEM fuel cell, there exist other types of fuel cell technology. Designs involving an ion-conducting material that range from a liquid alkaline or acid fixed in a matrix as carrier to molten inorganic salts.

Several other fuel cell designs are compared in [Table 29](#).

Fuel Cell Type	Common Electrolyte	Operating Temperature	System Output	Electrical Efficiency	Combined Heat and Power (CHP) Efficiency	Applications	Advantages
Polymer Electrolyte Membrane (PEM)*	Solid organic polymer poly-perfluorosulfonic acid	50 - 100°C 122 - 212°F	<1kW – 250kW	53-58% (transportation) 25-35% (stationary)	70-90% (low-grade waste heat)	<ul style="list-style-type: none"> - Backup power - Portable power - Small distributed generation - Transportation - Specialty vehicles 	<ul style="list-style-type: none"> - Solid electrolyte reduces corrosion & electrolyte management problems - Low temperature - Quick start-up
Alkaline (AFC)	Aqueous solution of potassium hydroxide soaked in a matrix	90 - 100°C 194 - 212°F	10kW – 100kW	60%	>80% (low-grade waste heat)	<ul style="list-style-type: none"> - Military - Space 	<ul style="list-style-type: none"> - Cathode reaction faster in alkaline electrolyte, leads to higher performance - Can use a variety of catalysts
Phosphoric Acid (PAFC)	Liquid phosphoric acid soaked in a matrix	150 - 200°C 302 - 392°F	50kW – 1MW (250kW module typical)	>40%	>85%	<ul style="list-style-type: none"> - Distributed generation 	<ul style="list-style-type: none"> - Higher overall efficiency with CHP - Increased tolerance to impurities in hydrogen
Molten Carbonate (MCFC)	Liquid solution of lithium, sodium, and/or potassium carbonates, soaked in a matrix	600 - 700°C 1112 - 1292°F	<1kW – 1MW (250kW module typical)	45-47%	>80%	<ul style="list-style-type: none"> - Electric utility - Large distributed generation 	<ul style="list-style-type: none"> - High efficiency - Fuel flexibility - Can use a variety of catalysts - Suitable for CHP
Solid Oxide (SOFC)	Yttria stabilized zirconia	600 - 1000°C 1202 - 1832°F	<1kW – 3MW	35-43%	<90%	<ul style="list-style-type: none"> - Auxiliary power - Electric utility - Large distributed generation 	<ul style="list-style-type: none"> - High efficiency - Fuel flexibility - Can use a variety of catalysts - Solid electrolyte reduces electrolyte management problems - Suitable for CHP - Hybrid/GT cycle

Figure 29. Comparison of Fuel Cell Technology

3.6.6. Case Study: UAV application

To better understand what exactly could be gained from studying the advancements in technologies such as fuel research and development, engine cycle efficiency, and battery chemistry, an extrapolation of performance parameters for two UAV platforms was conducted. The *MQ-1 Predator* and the *RQ-4 Global Hawk*, perhaps two of the most publicized UAVs, were analyzed using estimations of increased engine cycle efficiency and advanced synthetic fuel net heat of combustion estimations.

[Table 13](#) shows the effect engine cycle efficiency alone has on the Predator and Global Hawk flight characteristics. Assuming the numbers for 2010 are the current operating specifications, the expected increase in its three key combat parameters can be mapped out over decade long intervals until 2030:

	Radius (nm)			Coverage Area (nm ²)			Endurance (hours)		
	<i>(Current)</i>			<i>(Current)</i>			<i>(Current)</i>		
	2010	2020	2030	2010	2020	2030	2010	2020	2030
RQ-4 Global Hawk	5400	5940	6210	9.16E+07	1.11E+08	1.21E+08	36	39.6	41.4
MQ-1 Predator	500	550	575	7.85E+05	9.50E+05	1.04E+06	40	44	46

TABLE 13. UAV PERFORMANCE PREDICTION FOR YEAR MILESTONES - ENGINE EFFICIENCY ONLY.

[Table 14](#) shows the added effect of increased net heat of combustion (by weight) in addition to engine cycle efficiency increases shown from [Table 13](#) above:

	Radius (nm)			Coverage Area (nm ²)			Endurance (hours)		
	<i>(Current)</i>			<i>(Current)</i>			<i>(Current)</i>		
	2010	2020	2030	2010	2020	2030	2010	2020	2030
RQ-4 Global Hawk	5400	5940	6588	9.16E+07	1.11E+08	1.36E+08	36	39.6	43.92
MQ-1 Predator	500	550	610	7.85E+05	9.50E+05	1.17E+06	40	44	48.8

TABLE 14. UAV PERFORMANCE PREDICTION FOR YEAR MILESTONES - ENGINE AND FUEL EFFICIENCY.

The combined increase displayed is 22%. This is a fairly conservative 15% increase in engine efficiency plus a 7% increase in net heat of combustion (by weight). The two tables above can be seen graphically below in [Figure 30](#).

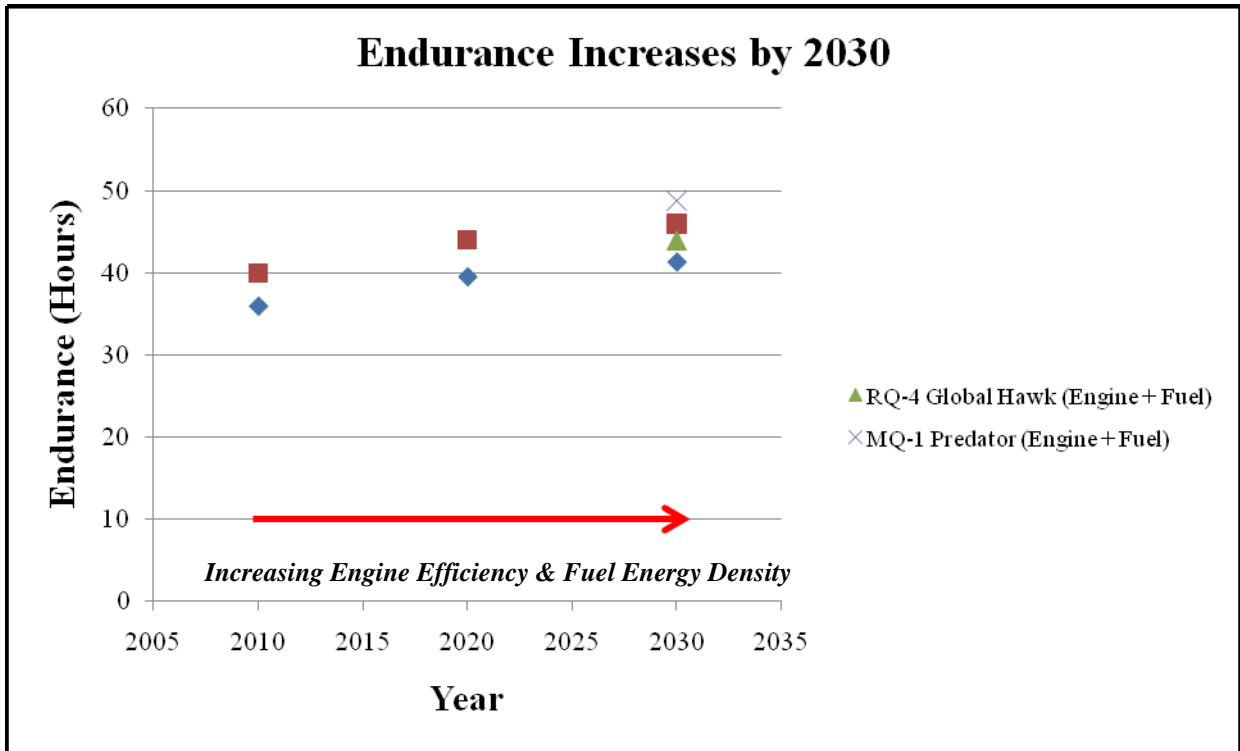

Figure 30. Endurance Increases by 2030 for the Predator & Global Hawk UAV's

Applying generalized increases in efficiency values and increase in net heat of combustion (by weight) as direct percentages was assumed valid by implementing the Breguet Range Equation.

$$Range = \frac{V}{g} \frac{1}{SFC} \frac{L}{D} \ln \left(\frac{W_{initial}}{W_{final}} \right)$$

Equation 1: Breguet Range Equation

Assuming the velocity of the platform (V), the Earth's gravitational constant (g), the platforms lift-to-drag ratio (L/D) and natural log of platform initial and final weights remain constant, the specific fuel consumption (SFC) can be changed to reflect efficiency increases.

3.7. Legal Consideration

A high level assessment of legal considerations was conducted. This section addressed legal constraints and areas to understand the access of Unmanned Systems to national and international waterways and airspace.

The Department of Defense Directive (DoDD) requires all DoD activities be fully compliant with any and all arms control agreements of the U.S. Government. Additionally DoDD 5000.1 requires that the acquisition and procurement of any DoD weapons and weapon systems shall be compliant with any and all applicable domestic law and treaties and international agreements. U.S. Government arms control agreements relating to unmanned systems (UMS) included the Wassenaar Arrangement (WA), the Missile Technology Control Regime (MTCR), the Treaty on Conventional Armed Forces in Europe (CFE), the Vienna Document 1999 (VDOC), Intermediate-Range Nuclear Forces Treaty (INF), Global Exchange of Military Information (GEMI), and the United Nations Transparency in Armaments Resolution (UNTIA). Conventional arms agreements that do not name MS, but include air and ground military vehicles include CFE, VDOC, INF, GEMI, and UNTIA. WA and MTCR are conventional arms agreements that directly address UMS.⁹⁶

3.7.1. International Laws

3.7.1.1. Law of Armed Conflict

“The Law of War” or “Law of Armed Conflict” is the customary and treaty law applicable to the conduct of warfare on land and the relationships between belligerents and neutral states. It requires that belligerents refrain from employing any kind or degree of violence which is unnecessary for military purposes and that they conduct hostilities with regard for the principles of humanity and chivalry.”⁹⁷ This in and of itself poses a level of autonomy which is unachievable with today’s technology.

⁹⁶ FY2009-2034 *Unmanned Systems Integrated Roadmap*, Pentagon, Washington, DC, April 2009, p 42.

⁹⁷ McDaniel, Erin A, “Robot Wars: Legal and Ethical Dilemmas of using Unmanned Robotic Systems in 21st Century Warfare and Beyond,” Fort Leavenworth, Kansas: U.S. Army Command and General Staff College, 2008, p 15.

The Law of Armed Conflict could limit the applicability of weaponized unmanned systems in future combat environments and would need to be addressed on the level of International Law.

The legality of using an autonomous vehicle to kill enemy forces will be a concept that needs further study. The difficulty with this concept is that will humans allow the vehicle's software be the deciding factor on who is an enemy and therefore should be attacked. An additional question is "Who is responsible when an autonomous vehicle conducts "murder" (ie kills an innocent person)?"

3.7.1.2. United Nations Convention on the Law of the Sea (UNCLOS)

All US Naval Ships must fully adhere to the UNCLOS or as they are commonly referred to as the "Rules of the Road"⁹⁸. Any UMS that is used no matter the level of autonomy that it possesses must also comply with the "Rules of the Road". This means that in addition to the Command and Control required to operate they must also be programmed to follow the rules of the road. This will be one of the engineering challenges that must be met for UMS to operate smoothly in the future force structure.

3.7.1.3. International Civil Aviation Organization (ICAO)

At a minimum, Unmanned Air Systems will need to follow International Civil Aviation Organization rules and regulations. In addition, due to unique restrictions not seen in manned aviation, further regulation may be put on Unmanned Air Systems while in International Airspace.

3.7.2. National Sovereignty

The entry of any vessel or aircraft, including Unmanned Systems, into the territorial seas or airspace of any country would need prior consent by that country, except in reference to Safe Haven, Innocent Passage, or Assistance Entry. The use of unmanned vehicles in or near territorial waters/airspace will require laws to go beyond

⁹⁸ COMDTINST M16672.2D, NAVIGATION RULES, available from <http://www.navcen.uscg.gov>, accessed 20 January 2010

what is currently written. The moral or ethical question of programming machines to employ lethal force has increasingly become an important element that will require laws at the international level.

3.7.3. Issues within the United States

Currently, the American Society for Testing and Materials (ASTM) International Committee F38 was selected by the U.S Federal Aviation Administration (FAA) to develop industry standards for small Unmanned Systems. These standards will be essential in allowing small UMS to have filed flight plans and to fly missions within the national airspace in conjunction with manned aircraft.⁹⁹ Additionally, these standards would be a stepping stone in allowing larger UMS the authorization to fly within current FAA controlled airspace.

Any Unmanned Surface Vehicle must integrate within the Coast Guard International Regulations for Avoiding Collisions at Sea (COLREGS), also known as the “Marine Rules of the Road”. Besides additional regulations specifically geared towards Unmanned Systems the vehicles must use high levels of autonomous guidance, navigation and control systems that provide advanced collision avoidance software.

⁹⁹ ASTM International, “ASTM to Develop Small Unmanned Air Vehicle Systems Standards for FAA”, available from <http://engineers.ihs.com/news/2010/astm-unmanned-air-vehicle-systems-030110.htm>, accessed May 16, 2010.

THIS PAGE INTENTIONALLY LEFT BLANK

4.0. SYSTEM ANALYSIS

4.1. FUNCTIONAL ARCHITECTURE

4.1.1. Functional architecture Development

4.1.1.1. *Functional Architecture Description*

The functional architecture for the SEA-16 Integrated Project contains a hierarchical model of the functions performed by the system, functional flow block diagrams, and diagrams showing the flow of inputs to and outputs from the functions. The functional architecture also contains the Measures of Effectiveness (MOEs) which measure the outputs of the system functions.

Before the functional architectural products are shown, some basic definitions will be given to clarify what is being described. The first item described is the definition of a system's functions. Dennis Buede defines and describes the nature of a system's functions below:

A function is an activity or task that the system performs to transform some inputs into outputs. Every function has activation and exit criteria. The activation criterion is associated with the availability of the physical resources, not necessarily with the start of the transformation activity. The function is activated as soon as the resource for carrying out the function is available. When the appropriate triggering input arrives, the function is then ready to receive the input and begin the transformation process. The activation criterion for the function then is the combination of the availability of the physical resource and the arrival of the triggering input. The exit criterion of a function determines when the function has completed its transformation tasks.¹⁰⁰

¹⁰⁰ Buede, Dennis, M, *The Engineering Design of Systems* (New York: John Wiley & Sons, Inc., 2000), 178.

Buede's definition emphasizes that a function describes the action taken by the system to transform an input to an output. The input could be information, material resources, electromagnetic signals, energy, or other resources that must be acted upon by an element in the system. The transformation of the resource results in an output that is useful to either another physical element of the system or to an external stakeholder. The usefulness of the output are classified and measured using MOEs.

A functional hierarchy or decomposition is a representation of a how a function is broken down into its sub functions. The functional hierarchy created was a structured top down beginning with the top level function, Manage UV Operations, and decomposing level by level to the lowest level functions. The functions are decomposed in as much detail as required but not all functions are decomposed to the same level of detail.

Buede states that functional flow block diagrams (FFBDs), "provide a hierarchical decomposition of the system's functions and show a show a control structure that dictates the order in which the functions can be executed at each level of the decomposition."¹⁰¹ Some important details portrayed in the FFBDs are whether functions are executed in series or parallel, and whether they are completed once or multiple times before meeting exit criteria. Throughout the FFBDs, the system is described in a fully operational mode.

A critical component of the success of the functional hierarchy is the conservation of all the inputs to and outputs from the top level function.¹⁰² Conservation of inputs and outputs means that all inputs to the decomposition are utilized by the system and are consumed by a transformative activity.

The input/output diagrams detail the inputs to the functions and the resulting outputs. The diagrams show how the inputs enter the system from the external

¹⁰¹ Buede, Dennis, M, *The Engineering Design of Systems* (New York: John Wiley & Sons, Inc., 2000), 340.

¹⁰² Buede Buede, Dennis, M, *The Engineering Design of Systems* (New York: John Wiley & Sons, Inc., 2000), 178.

environment, and how these inputs are transformed and transferred internally until a final output is achieved and sent to the external environment.

The MOEs show how the outputs from the functions are measured for their effectiveness. As was discussed in Section 2.5, the effectiveness of C2 is tied to the accomplishment of the mission. Therefore, the outputs of the functions are measured for specific areas that relate to mission accomplishment.

4.1.1.2. Developing the Functional Architecture

The functional architecture was created using the process contained in chapter seven of Dennis Buede's text, *The Engineering Design of Systems*, as summarized below:

Step 1: The team analyzed the concept of operations, the joint systems concept, and originating requirements. The team sought to gain a better understanding of the system bounds, the problem the system is going to solve, and the level of decomposition that would be required. The team then created functional steps that satisfied the vignettes in the concept of operations. [Figure 31](#) illustrates the inputs to the creation of the functional architecture. The mechanism the team used to perform the functional architecture is a systems engineering software tool called CORE that is produced by a company called Viacom.

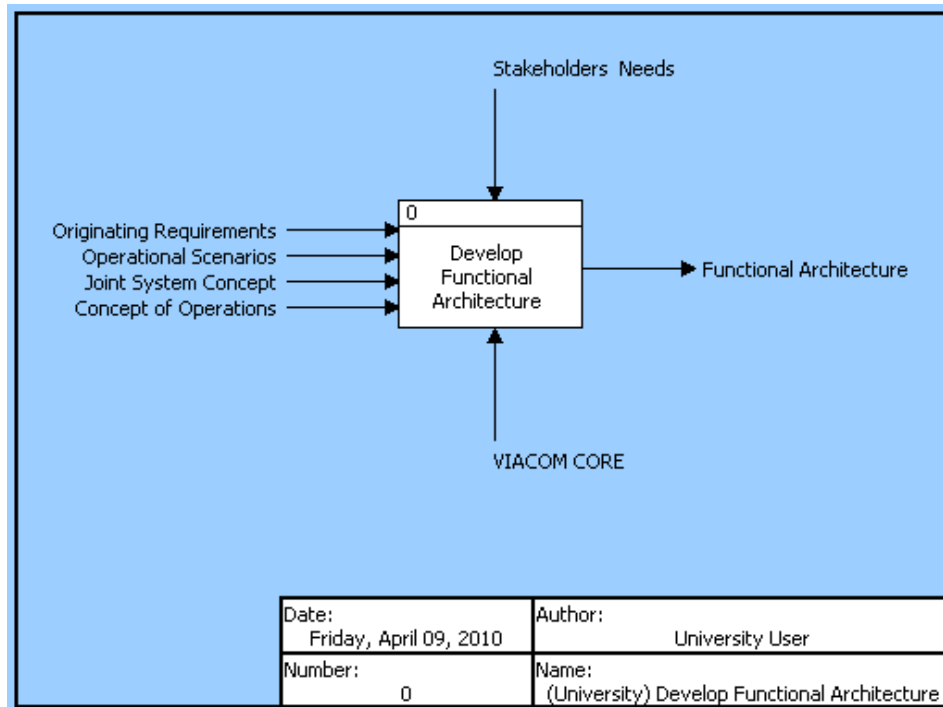

Figure 31. Developing Functional Architecture

Step 2: The team combined these functions into a functional decomposition. The team analyzed the input flows from outside the system. The team then reconfirmed the functional decomposition against operational concept to ensure completeness. The steps taken to create the functional decomposition are illustrated in [Figure 32](#), and detailed below:

1. Determined purpose and viewpoint of the system as developed in the Joint Systems Concept and the Concept of Operations.
2. Developed external systems diagram in order to bound the system.¹⁰³ The diagram can be created from the operational concept and should be consistent with the scenarios developed in the Joint Concept. All inputs from external systems and controls that enter system through external interfaces are identified as well as the outputs.
3. Developed data list from external systems diagram.

¹⁰³ Buede, Dennis, M, *The Engineering Design of Systems* (New York: John Wiley & Sons, Inc., 2000), 144.

4. Generated activity list.
5. Defined A-O diagram and the level 1 functional decomposition.¹⁰⁴
6. Continue process decomposition to levels 1, 2, 3, and 4, as applicable.

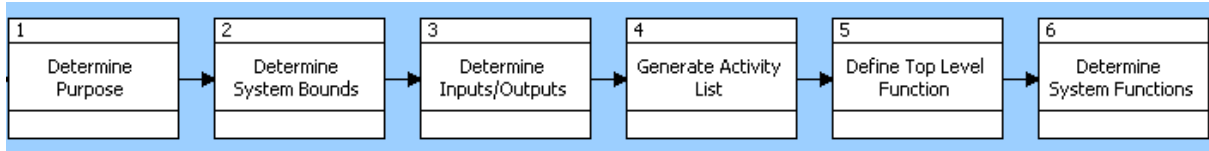

Figure 32. Decomposition Process

Step 3: Address data or item that serve as inputs or outputs to functions of the functional architecture. Coordinate item flow with the work being conducted by the C2 architecture task force.

Step 4: Develop MOEs to determine the effectiveness of each function.

Step 5: Show the functional architecture at a Steering Committee meeting in order to receive feedback and suggestions for improvement.

4.1.2. Functional Architecture Overview and Summary

4.1.2.1. Description

This architecture is for the command and control of unmanned vehicles in year 2030, including the interface between unmanned vehicles operating in all domains (air, undersea, surface, land, and space), C2 nodes, other operational units, and external systems. The principal exchange of information is through a collaborative network which acts a data fusion network that is distributed across the forces.

4.1.2.2. Purpose and Scope

The purpose of this architecture is to describe the integration of unmanned and manned vehicles in all domains into a collaborative knowledge sharing environment,

¹⁰⁴ Buede, Dennis, M, The Engineering Design of Systems (New York: John Wiley & Sons, Inc., 2000), 66.

allowing for unity of effort amongst all the warfare tools in the battlespace. The architecture is focused toward unmanned vehicles, but takes into account the integration of manned vehicles through the collaborative network. Knowledge sharing via the collaborative network is a principle way that manned and unmanned vehicles are integrated.

The internal aspects of the system include the C2 assets, unmanned vehicles, manned vehicles, communication equipment, and the collaborative network. External to the system is the operational environment, threats, other coalition partners, local populations, higher command centers, and other elements not contained in the system.

4.1.2.3. Mission

The primary mission that the functional architecture accomplishes is C2. C2 is the exercise of authority and direction by a properly designated commander over assigned and attached forces in the accomplishment of the mission. C2 functions are performed through an arrangement of personnel, equipment, communications, facilities, and procedures employed by a commander in planning, directing, coordinating, and controlling forces and operations in the accomplishment of the mission.¹⁰⁵

4.1.3. Functional Description

4.1.3.1. Manage UV Operations

The top level function, Manage UV Operations, includes the operation of unmanned vehicles, the command and control of the unmanned vehicles, and the collaborative communication and interface between system nodes. The function is described showing various figures and tables to show the hierarchy, functional flow, and input/outputs. [Figure 33](#) shows the hierarchy relationship of these functions and [Figure 34](#) shows the functional flow of these functions. [Figures 35](#) and [Figure 36](#) show the inputs to and the outputs from the top level function.

¹⁰⁵ U.S. Department of Defense, Joint Publication 1-02, *DOD Dictionary of Military and Associated Terms*, October 2009.

[Figure 33](#). shows how the top level function is decomposed to the first level. Manage UV operations includes the operation of unmanned vehicles, the command and control of the unmanned vehicles, and the communication and interface between architecture nodes. Provide C2 is the means and methods by which a commander recognizes what needs to be done in any given situation and sees that the appropriate actions are taken. Collaboration is the communication and knowledge sharing between operational nodes in order to increase each node's understanding of the current operational situation. Operate UVs is the performance of operational activities by UVs in the ballet space. Activities include sensor operation, communication, and task execution.

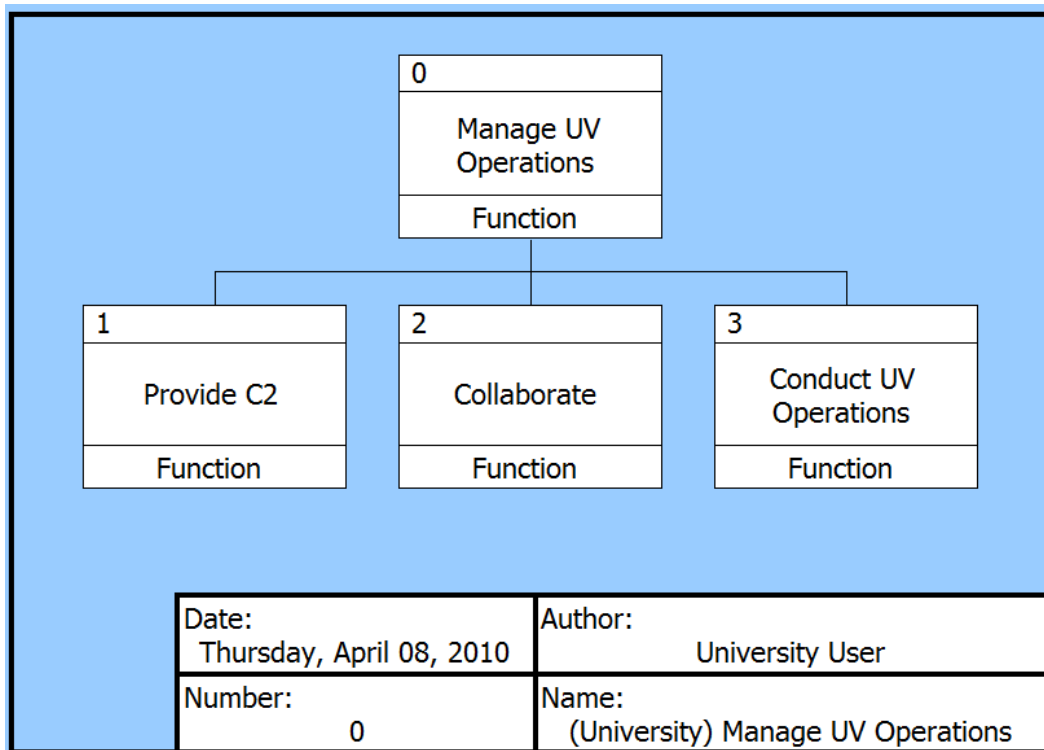

Figure 33. Manage UV Operations Hierarchy Diagram

The overall intent of the architecture is to manage unmanned vehicle operations in the 2030 battlespace. In order to achieve the overall management of UV operations in the 2030 battlespace, the architecture enables the C2 of unmanned vehicles operating in an environment. The function Collaborate allows knowledge sharing amongst UVs, manned vehicles, other interested entities such as coalition partners.

[Figure 34.](#) illustrates the functional flow of the functions which decompose the top level function Manage UV Operations. Conduct UV Operations, Collaborate, and Provide C2. The parallel structure indicates that the functions occur concurrently. While the architecture is in the operational mode, the functions occur in a continuous loop. Through the collaboration between UVs, manned vehicles, C2 nodes, and other external agencies, the architecture allows the C2 of operational UVs that are conducting missions such as surveillance and force protection.

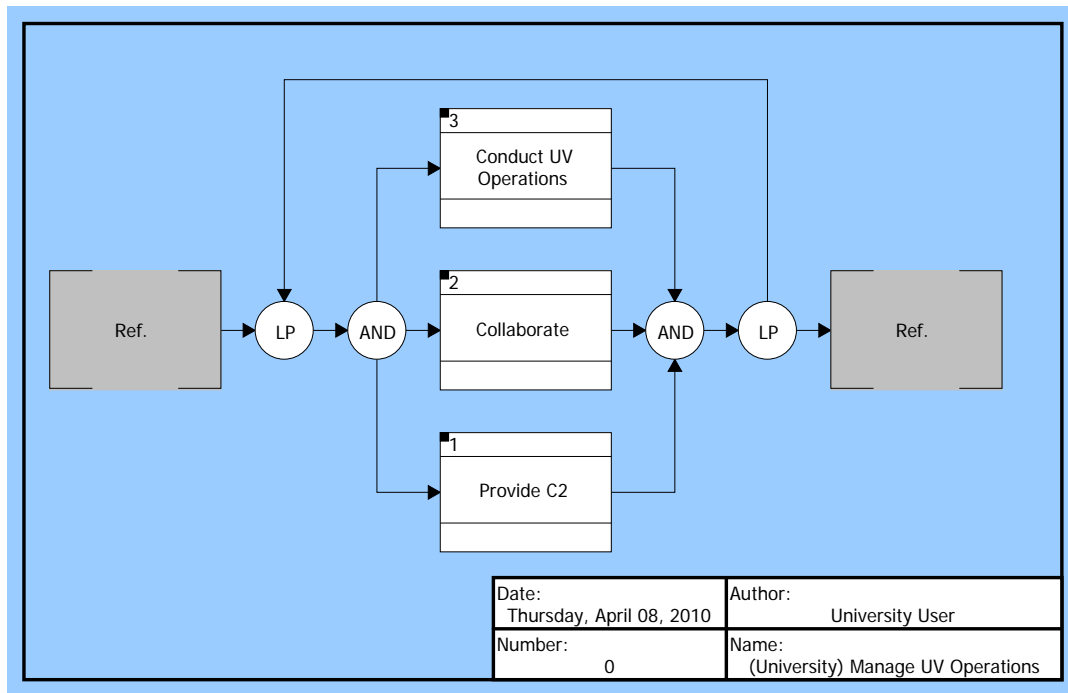

Figure 34. Manage UV Operations FFBD

[Figure 35](#) represents the inputs to the system from the external environment. Operational constraints include conditions that could hamper the C2 of UVs. For example, emission control conditions, electronic warfare threats, air space management considerations, natural disaster considerations, and others. Observables could be vibrations, electromagnetic radiation, acoustic waves, and many other observables. These are sensed by UVs and this data is relayed to other UVs and the fused picture is relayed to the collaborative network. Limiting constraints are an organized display of constraints that are limiting to a particular course of action or scenario. Constraints include conditions that could hamper the C2 of UVs. For example, emissions control situations, electronic warfare threats, and kinetic threats from enemies. Join Network Requests are requests made by external nodes to interface with the network. Information Requests are requests made by external nodes for information that is contained in the Collaborative Network. Higher Command Data are orders and guidance sent by a command outside of the Collaborative Network.

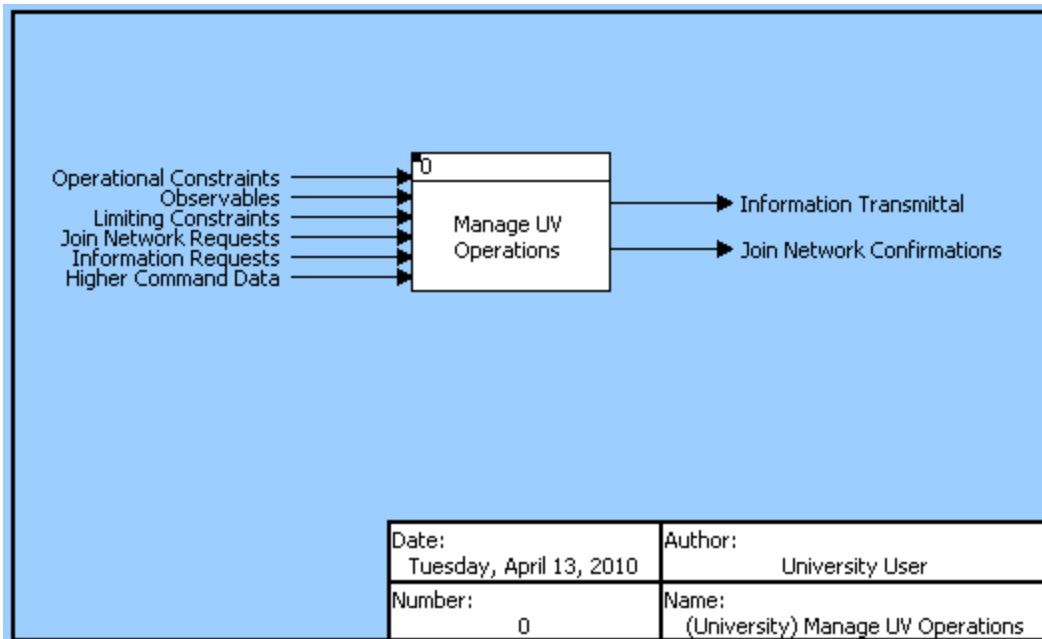

Figure 35. Manage UV Operations IDEF A-0 Context Diagram

The inputs are received by the system and transformed as shown in [Figure 36](#). The outputs that result are Information Transmittals and Join Network Confirmations. Information Transmittals are the transmittals of information that was requested of the network. Joint Network Confirmations are the confirmations sent to external nodes by the Collaborative Network indicating that the request to join the network has been confirmed, thus establishing a network connection.

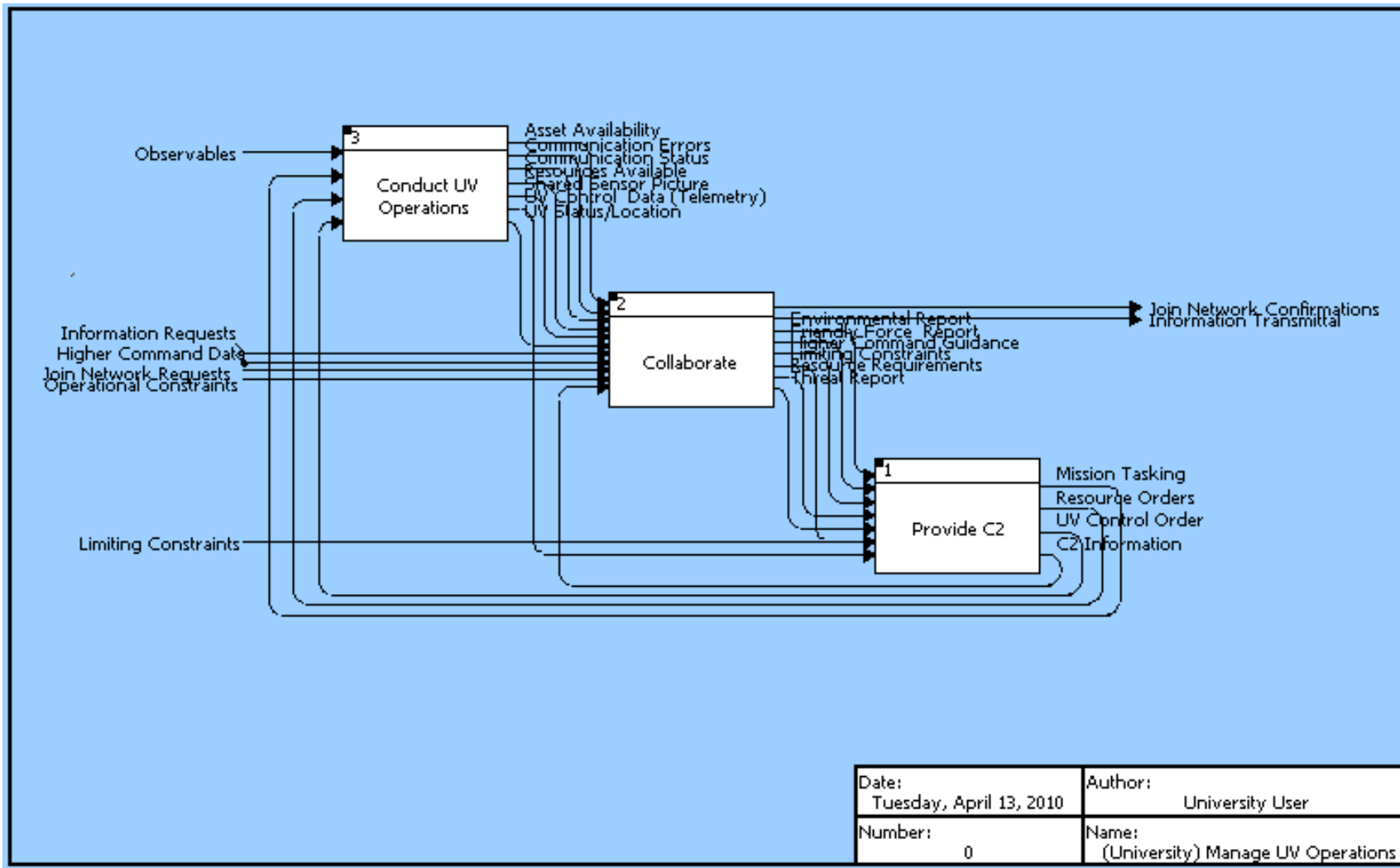

Figure 36. Manage UV Operations Input/Output Diagram

[Figure 36.](#) illustrates how the inputs from the external environment are transformed internally by the system, which result in internal transfers of information and outputs to the external environment. This diagram provides the overall view of how the inputs are transformed to outputs. Inputs from the external environment enter all three first level functions with the vast majority entering the system at the Collaborate function. The inputs are transformed by the first level functions, with resulting outputs being transferred to both the external environment and internally amongst the system.

[Table 15,](#) provides a comprehensive functional decomposition of Manage UV Operations. Each first level function, Provide C2, Collaborate, and Conduct UV Operations, including their decomposition, inputs, and outputs are described in more detail in the rest of this section.

0 Manage UV Operations				
1 Provide C2	1.1 Observe	1.1.1 Monitor Situation	1.1.1.1 Monitor Internal Factors 1.1.1.2 Monitor External Factors	
	1.2 Orient	1.2.1 Understand Situation	1.2.1.1 Assess Friendly Capability 1.2.1.2 Assess Threat 1.2.1.3 Analyze Environment	
		1.2.2 Identify Mission Success Gap		
	1.3 Decide	1.3.1 Determine COA	1.3.1.1 Develop COA 1.3.1.2 Analyze COA	1.3.1.2.1 Assess Risk 1.3.1.2.2 Analyze Timing 1.3.1.2.3 Select COA
			1.4 Act	1.4.1 Command Assets
1.5 Share to Network				
2 Collaborate	2.1 Operate in Network	2.1.1 Establish Capability Interface		
	2.2 Manage Data	2.2.1 Organize Data 2.2.2 Share Data		
		2.3 Collect Data		
	2.4 Secure Network			
3 Conduct UV Operations	3.1 Operate Sensors	3.1.1 Sense Environment		
		3.1.2 Share Raw Sensor Data		
3.1.3 Fuse Sensors				
3.1.4 Share Sensor Picture				
3.2 Operate UVs	3.2.1 Formulate Tactics 3.2.2 Schedule and Allocate Tasks 3.2.3 Navigate/Execute Task 3.2.4 Report Position/Status 3.2.5 Assess/Report Operational Availability			

TABLE 15. MANAGE UV OPERATIONS HIERARCHY.

[Table 16](#) contains a list of all the functions and information items and their associated definitions. The definitions are as close to the definitions found in Joint Publication 1-02 with tailoring where appropriate. These definitions assist the understanding of the functional and input/output descriptions for Manage UV Operations and its subordinate functions.

Element	Definition
Function	
0 Manage UV Operations	This function includes the operation of unmanned vehicles, the command and control of the unmanned vehicles, and the communication and interface between architecture nodes.
1 Provide C2	The means and methods by which a commander recognizes what needs to be done in any given situation and sees that the appropriate actions are taken. It subsumes the process of building situational awareness. Intelligence, surveillance, and reconnaissance activities thus support command and control. Command and control likewise encompasses combat direction, the real-time management of weapons systems. Command is the exercise of authority and control is the information returning to the commander about the results of the action taken - which informs subsequent command action. The commander decides what needs to be done and directs the actions of others. Feedback reveals the difference between intended outcomes and the situation as it actually develops. Feedback thus allows the commander to adapt to changing circumstances. Control is a state the entire system achieves based on feedback about the developing situation.
1.1 Observe	To watch the operational situation carefully taking into account details of a situation. The main goal of this function is to be able to process enough information to make sound judgments regarding an operational situation.
1.1.1 Monitor System	To obtain information on the mission, enemy forces, neutral/non-combatants, friendly forces, terrain, and weather.
1.1.1.1 Monitor Internal Factors	Identifying and considering force readiness, including assets available, asset operational status, communication status, and resource requirements.
1.1.1.2 Monitor External Factors	Identifying and considering elements external to the system. Examples include weather factors, enemy activities, limits on electromagnetic radiation, and guidance from higher commands.
1.2 Orient	To acquaint with the current situation and environment. The goal of the function Orient is to compare mission criteria to the current situation and identify ways to ensure the mission is being accomplished.
1.2.1 Understand Situation	To acquaint with the current situation and environment.
1.2.1.1 Assess Friendly Capability	Identify the capabilities that the friendly forces can employ in a situation. For example, are there enough UVs to conduct effective surveillance of an operational area?
1.2.1.2 Assess Threat	Given contacts and engageable tracks, classify, type, identify, and evaluate the threat posed to friendly assets and areas.

1.2.1.3 Analyze Environment	Take into account the physical environment and the effects on the UV missions. For example, barometric pressure, temperature, humidity, visibility, salinity of water, and wind.
1.2.2 Identify Mission Success Gap	Identify gap between the desired state and the current situation. This could also involve measuring the gap between enemy capability and friendly capability.
1.3 Decide	To make a final choice on a course of action (COA).
1.3.1 Determine COAs	The function of choosing a COA. This function includes the process of choosing a COA.
1.3.1.1 Develop COAs	Develop a couple of alternative solutions to the impending problem.
1.3.1.2 Analyze COAs	Taking the nominative COAs and weighing these COAs against the criteria of risk and timing.
1.3.1.2.1 Assess Risk	Analyze the COAs and compare against possible enemy courses of actions. Take into account mission criteria, limitations, and time criticality.
1.3.1.2.2 Analyze Timing	Understand how fast a decision and action must be rendered. Less time critical events allow more analysis where time critical events require very rapid decision making and subsequent action.
1.3.1.2 Select COA	Determine courses of action that best meets mission objectives, while minimizing risk when appropriate.
1.4 Act	The decision maker puts the decision into action, which may involve disseminating the decision to others for execution, supervising that execution, and monitoring results through feedback. The Collaborative Network concept envisions that immediate dissemination of dynamic plans across the entire network, to any node or echelon desired. These plans would update automatically in real time, decreasing the need to publish changes and eliminating the time required to do it.
1.4.1 Command Assets	Command is the exercise of authority, including assigning missions, directing UVs, and providing resources.
1.4.1.1 Assign Mission	After an analysis and decision are rendered, the system must be able to process the decision and give mission tasking to required assets.
1.4.1.2 Direct UVs	Unmanned vehicles must be directed as required given UV level of autonomy. The level of autonomy of the UV will vary given the particular mission and

	environment; thus the system must be able to direct UVs in low to high autonomy situations.
1.4.1.3 Provide Resources	Provide required assets, fuel, and support as dictated by the operational environment, friendly capability, and time criticality.
1.5 Share to Network	The passing of C2 Node information to the Collaborative Network in order to enhance collaboration.
2 Collaborate	To communicate and share knowledge with other operational nodes in order to increase each node's understanding of the current operational situation.
2.1 Operate in Network	The ability to exploit all human and technical elements of the force and its mission partners by fully integrating collected information, experience, knowledge, and decision making via a collaborative network. Data and information are securely shared via the network, enhancing each individual node's awareness. The network will connect all nodes including UVs that conduct operations, manned assets and C2 nodes that provide the Command and Control to operational assets. The goal is a seamless integration between manned and unmanned assets across all domains with the appropriate C2 node.
2.1.1 Establish Capability Interface	Establish Capability Interface is the sharing of needed operational information when information is entered via a user capability interface or through a sensor transduction capability interface.
2.2 Manage Data	Given information, ensure decision makers have ready access to the information they want and need while minimizing the risk of information overload.
2.2.1 Organize Data	The filtering, prioritizing, and manipulating to present observable reports. The goal is to present information to C2 nodes that is useful and manageable, not overwhelming.
2.2.2 Share Data	Operational nodes must be able upload information to a Collaborative Network in order to increase each internal operational node's understanding of the situation and also to inform external stakeholders that interface with the network.
2.3 Collect Data	The system must be able to receive information from external stakeholders, such as unmanned vehicles, targets, and external agencies.
2.4 Secure Network	Information in the operational nodes and network must protect information from information attacks carried out by hackers and enemies.
3 Conduct UV Operations	Carrying out operational missions via unmanned vehicles. Missions could include force protection and reconnaissance missions. This set of functions will focus on the functions that allow the navigation and task completion by UVs, as well as the communication to and from the collaborative network and the C2 nodes.
3.1 Operate Sensors	The utilization of sensors onboard UVs, such as optical, IR, acoustic, weather reading, RADAR, temperature, CBR, and other sensors that are utilized by vehicles.
3.1.1 Sense Environment	Identifying, reading, and exploiting of observables in the environment. Observables could be vibrations, electromagnetic radiation, acoustic waves, and

	many other forms of stimuli.
3.1.2 Share Raw Sensor Data	Sending sensor data to other vehicles in the vicinity for greater situational awareness amongst operational nodes. These other vehicles could be other UVs or manned vehicles.
3.1.3 Fuse Sensors	Taking many different sensor feeds and combining them to create a situational picture or sensor picture. For example, an optical target could be correlated to an acoustic or radar target, thereby giving the type of target, and the course and speed of target.
3.1.4 Share Sensor Picture	The sending of the fused sensor picture to the collaborative network and other vehicles.
3.2 Operate UVs	The performance of operational activities by UVs in the battlespace. Activities include navigation, planning, task execution, and reporting.
3.2.1 Formulate Tactics	Utilizing the artificial intelligence capabilities of UVs, the sensor picture from UVs, and inputs from C2 nodes, a tactical plan is formulated. The tactical plan includes maneuver information, sensor usage, weapon usage, and other relevant tactical tasks for a given situation.
3.2.2 Schedule and Allocate Tasks	Given a tactical plan, the determination of specific tasks required to accomplish the plan. The tasks are scheduled and allocated to different assets.
3.2.3 Navigate and Execute Tasks	Maneuver in a given environment and the carrying out of tasks.
3.2.4 Report Position Status	Provide the collaborative network and required operational assets updates on position and the status of the task completion. This provides situational awareness to the nodes in the network.
3.2.5 Assess/Report Operational Availability	Identify elements of the UVs and required equipment that may hinder the operational availability of the required assets.
Input/Output Items	
Join Network Requests	Requests made by external nodes to interface with the network.
Information Requests	Requests made by external nodes for information that is contained in the Collaborative Network.
Join Network Confirmations	The confirmation sent to the external node by the Collaborative Network indicating that the request to join the network has been confirmed, thus establishing a network connection.
Information Transmittal	The sending of information that was requested of the network.
UV Status	The data detailing where a UV is operating, where it can be available to operate,

/Location	and where it is in terms of tasking completion.
Resources Available	Data specifying resources available for UV operations. For example, how much fuel is available to sustain UVs for a particular operation? How many reserve UVs are available given casualties to UVs in the AO?
Higher Command Data	Orders and guidance sent by a command outside of the Collaborative Network.
Operational Constraints	Operational constraints include conditions that could hamper the C2 of UVs. For example, emission control conditions, electronic warfare threats, air space management considerations, natural disaster considerations, and others.
Communication Errors	Failures in the communications between nodes in the system. For example, this data would indicate a loss of communications to a UV.
Collected Data	Data that is received by a node in the C2 network.
Secured Data	Data that has been secured by the network.
Organized Data	Organized Data is the data which has been filtered, prioritized, and manipulated into an observable and understandable form.
UV Control Data (Telemetry)	Automatic measurement and transmission of unmanned vehicle data by wire, radio, or other means from remote sources, as from unmanned aerial vehicles, to receiving stations for recording, analysis, and control purposes.
Asset Availability	An organized report specifying which UV's and other assets such as manned vehicles are available for specific mission.
Communication Status	An organized report specifying whether or not a UV or other communication asset has positive communication.
Environmental Report	An organized report displaying data input to the Collaborative Network that specifies environmental parameters such as temperature, barometric pressure, wind speed, and level of humidity.
Friendly Force Report	An organized report specifying the operational capability of the forces assigned to a particular commander. This report can specify different levels of force readiness, such as forces available for a specific tactical engagement or an operational campaign.
Higher Command Guidance	Direction and orders input to the network from higher commands that alter the C2 of the systems.
Limiting Constraints	An organized display of limitations to a particular course of action or operational configuration. Constraints include conditions that could hamper the C2 of UVs. For example, emissions control situations, electronic warfare threats, and kinetic threats from enemies.
Threat Report	An organized display of the threat or enemy. The report details the nature of the threat such as the platform type, number of enemy forces, weapon system characteristics, any hostile actions, and tracking, targeting information.

Resource Requirements	An organized display of the resources required by internal nodes of the system.
Observed Reports	Reports that have been filtered by the network in the Manage Data function and are now observed in a manner that facilitates comprehension in the least amount of time possible.
Force Picture	The Force Picture assimilates the Observed Friendly Force Report, Observed Higher Command Guidance, Observed Limiting Constraints, Observed Asset Availability, Observed Resource Requirements, and Observed Communication Status. The Force Picture provides the situation in a manner that allows follow-on decision making.
Environmental Picture	A representation of the environmental situation, including parameters such as temperature, barometric pressure, wind speed, level of humidity, in a manner that allows follow on decision making. (barometric pressure, wind speed, and level of humidity)
Threat Picture	A representation of the threat that allows follow on decision making.
Mission Gap Picture	The mission gap picture is the result of the Force Picture, Threat Picture, and Environmental Picture. The threat is compared against the friendly forces in a given environment. The result is the indication of whether what is expected to be happening is actually occurring. This is a key element of the Control aspect of C2.
COAs	COAs that the commander developed to meet mission objectives. A couple of feasible options are generally generated in order to decide which option is best through analysis
Analyzed COAs	COAs that have been assessed and analyzed for their time criticality.
Selected COA	The selected COA is the COA that the decision maker has chosen after weighing factors such as the gap between the desired state and the actual state, risk, and timing factors.
Mission Tasking	Mission tasking is direction specifying the selected course of action and associated orders to a particular node.
Resource Orders	Required assets, fuel, and support as dictated by the operational environment, friendly capability, and time criticality.
UV Control Orders	UV control orders are orders given by the C2 node indicating a particular action to be taken by a UV. The level of control data will vary from a mission update to an autonomous UV to more consistent stream of control orders to less autonomous UVs.
Observables	Observables could be vibrations, electromagnetic radiation, acoustic waves, and many other observables. These are sensed by UVs and this data is relayed to

	other UVs and the fused picture is relayed to the collaborative network.
C2 Information	Information shared by C2 nodes from each stage of the OODA process in order to maximize the collaborative efforts of the network.
UV Tactical Plan	A plan detailing how the UVs will accomplish a particular mission. For example, the plan could indicate which sectors different UVs will need to monitor while conducting a force protection mission.
Tasking Order	A Tasking Order gives specific direction to assets in order to execute a plan.
UV Navigation/ Task Status	The UV Navigation/ Task Status is an update on the navigational information such as location, course, and speed of the UV and the completion progress of the tasks it was assigned to complete.
UV System Status	The information which allows the assessment of the UVs operational status, including communication status, communication errors, resource levels, and asset availability.
Shared Sensor Data	Sensor data that is transmitted from one vehicle to other vehicles in order to enhance situational awareness.
Shared Sensor Picture	Shared Sensor Picture is sensor data that has been fused by the master UV and then shared to the C2 network. A manned asset can also send sensor data. The sensors could include any relevant mix such as IR, Optical, RADAR, SAR, Acoustic, Radiological, etc.

TABLE 16. FUNCTIONS AND INPUT/OUTPUTS DEFINITIONS.

4.1.3.2. Provide C2

Provide C2 is the function which commands and controls the operational UVs. The model chosen to describe C2 is a modified Boyd's' OODA loop as discussed in [Section 3.1](#). C2 is defined as the means and methods by which the appropriate actions are taken. Feedback reveals the difference between intended outcomes and the situation as it develops. Feedback thus allows the system elements to adapt to changing circumstances. Control is a state the entire system achieves based on feedback about the developing situation.¹⁰⁶

The architecture products for Provide C2 are shown below in the same sequence as Manage UV Operations. [Figure 37](#). shows the hierarchy, [Figure 38](#). shows the functional flow. [Table 17](#) and [Figures 39](#). through [Figure 46](#). show the input/output of each function.

¹⁰⁶ U.S. Department of Defense, Joint Publication 1-02, *DOD Dictionary of Military and Associated Terms*, October 2009.

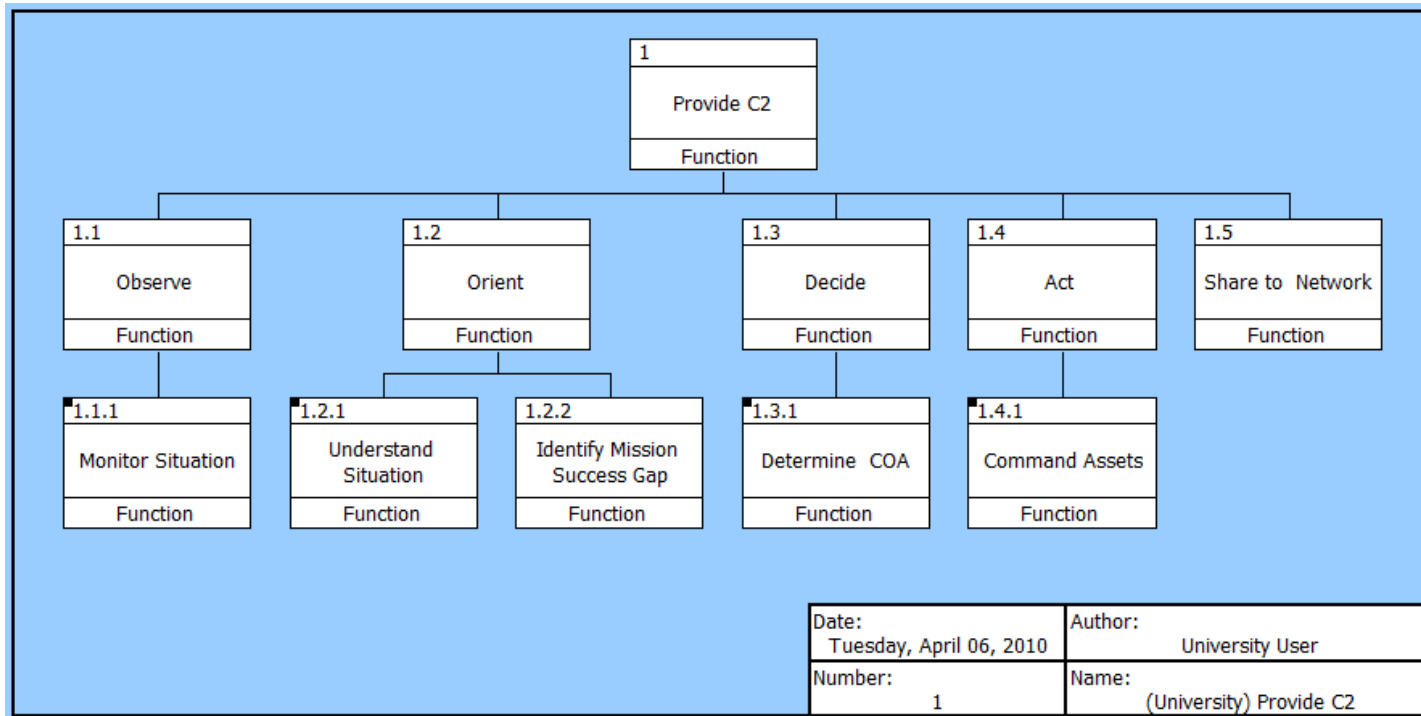

Figure 37. Provide C2 Hierarchy Diagram

[Figure 37](#) is the functional decomposition of Provide C2. Provide C2 is described using the Observe, Orient, Decide, Act, of Boyd's OODA loop with the addition of Share to Network. The black squares located on the upper left hand corner of the level three functions indicate that the level three functions are broken down to a further level as shown in [Table 17](#). The next several paragraphs detail the hierarchy of Provide C2 by defining each function and explaining the functional decomposition.

Observe entails watching the operational situation carefully taking into account details of a situation. The main goal of this process is to be able to handle enough information to make sound judgments regarding an operational situation. Observe is decomposed by Monitor the Situation. Monitor the Situation allows the commander to obtain information on the mission, enemy forces, neutral/non-combatants, friendly forces, terrain, and weather. Monitor the Situation is decomposed by Monitor Internal Factors and Monitor External Factors. Monitoring Internal Factors involves identifying and considering force readiness, including assets available, asset operational status, communication status, and resource requirements. Monitoring External Factors involves identifying and considering elements external to the system. Examples include weather factors, enemy activities, limits on electromagnetic radiation, and guidance from higher commands.

Orient allows the commander to acquaint with the current situation and environment. The goal of Orient is to compare mission criteria to the current situation and identify ways to ensure the mission is being accomplished. Orient is decomposed by Understand the Situation and Identify Mission Success Gap.

Understand the Situation involves becoming familiar with the current situation and environment. Understand the Situation is decomposed by Assess Friendly Capability, Assess Threat, and Analyze Environment. Assess Friendly Capability is the identification of the capabilities that the friendly forces can employ in a situation. For example, are there enough UVs to conduct effective surveillance of an operational area? Assess Threat involves the identification, classification, and evaluation of a threat posed to friendly assets and areas. Analyze Environment takes into account the physical

environment and the effects on the UV missions, for example, barometric pressure, temperature, humidity, visibility, salinity of water, and wind.

Identify Mission Success Gap identifies the gap between the desired state and the current situation.

Decide is to make a final choice on a course of action (COA). Decide is decomposed into Determine COA. Determine COA includes the actions involved in choosing a COA. Determine COAs is decomposed into Develop COAs and Analyze COAs. Develop COAs involves the development of a couple of alternative solutions to the impending problem. Analyze COAs involves taking the nominative COAs and weighing these COAs against the criteria of risk and timing. Analyze COAs is decomposed further into include Assess Risk, and Analyze Timing, and Select COA. Assess Risk involves the analysis of COAs with a comparison against possible enemy courses of action. The analysis takes into account mission criteria and limitations. Analyze Timing is to understand how fast a decision and action must be rendered. Less time critical events allow more analysis where time critical events require very rapid decision making and subsequent action. The final process of Decide is Select COA. Select COA is to determine COAs that best meets mission objectives, while minimizing risk when appropriate.

Act is where the decision maker puts the decision into action, which may involve disseminating the decision to others for execution, supervising that execution, and monitoring results through feedback. The Collaborative Network concept envisions the immediate dissemination of dynamic plans across the entire network, to any node or echelon desired. These plans would update automatically in near real time, decreasing the need to publish changes and eliminating the time required to do it. Act is decomposed by Command Assets which is further decomposed into Assign Missions, Direct UVs, and Provide Resources.

Command Assets is the exercise of authority, including assigning missions, directing UVs, and providing resources. Command Assets is decomposed to Assign Mission, Direct UVs, and Provide Resources. Assign Mission is what is done

autonomously or by the commander or representative of the commander after an analysis and decision are rendered, the system must be able to process the decision and give mission tasking to required assets. Direct UV's includes the control of UVs. Unmanned vehicles must be directed as required given UV level of autonomy. The level of autonomy of the UV will vary given the particular mission and environment; thus the system must be able to direct UVs in low to high autonomy situations. Provide Resources is the providing of required assets, fuel, and support as dictated by the operational environment, friendly capability, and time criticality.

Share to Network is the final sub function of Provide C2. Share to Network is the passing of C2 node information to the Collaborative Network in order to enhance collaboration. Sharing information to the network is critical in terms of enabling effective knowledge sharing and unity of effort amongst operation units in a battlespace.

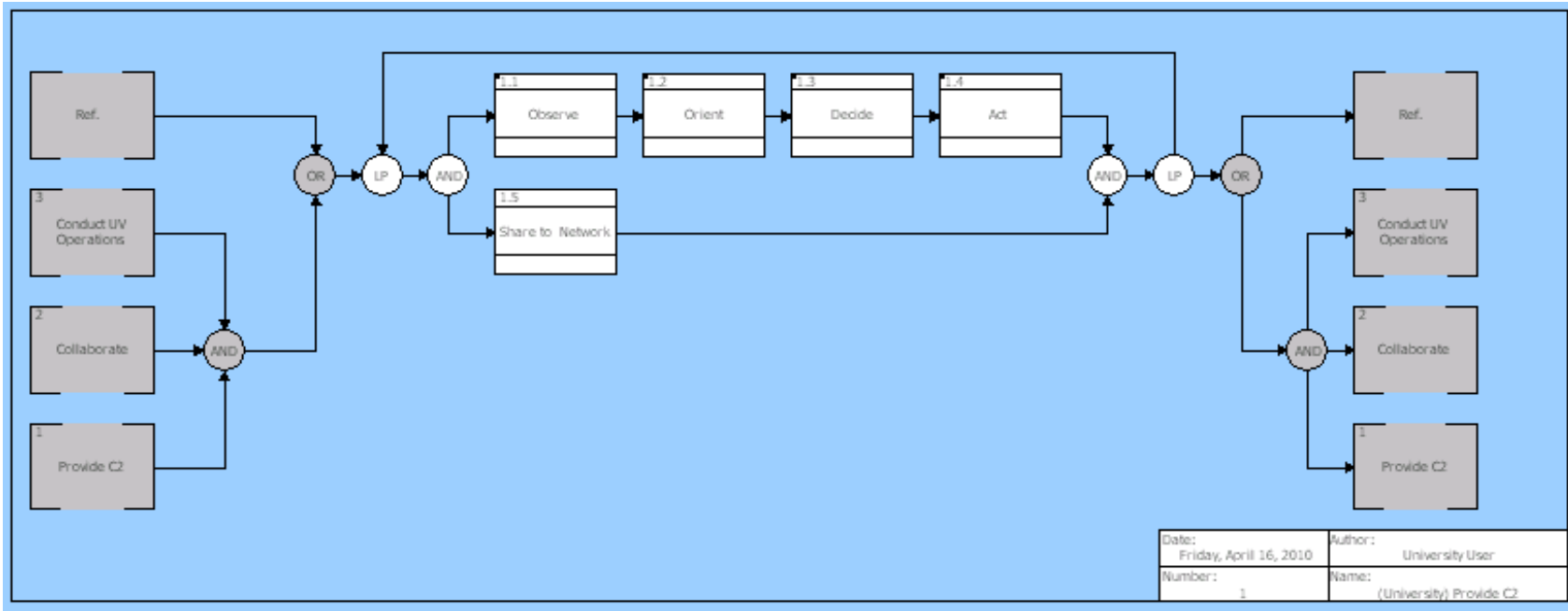

Figure 38. Provide C2 FFBD

[Figure 38.](#) is the FFBD for Provide C2. The diagram shows that the functions OODA and Share to Network happen in parallel and in a continuous loop while the system is in operational mode. The logic for placing the OODA steps in concert with Share to Network is to enable the sharing of information to the Collaborative Network at each stage of the OODA loop. For example, in a force protection mission, the commander receives information from unmanned vehicles that are in the Collaborative Network. The commander observes a Threat Report and the system communicates that the report has been observed. The Observed Threat Report is then moved in to the Orient step where the commander gains an understanding of the situation and determines what needs to be done. The commander's assessment from the Orient step is shared to the Collaborative Network in order to enhance other units' situational awareness. The same sharing occurs after a COA is determined in the Decide function. If there is a problem during in accomplishing the COA during the Act function, such as the C2 node being destroyed, another unit could assume command of the assets because there is a shared understanding of the problem.

[Table 17](#) provides a tabular representation of the inputs and outputs to Provide C2. This table will assist the understanding of the subsequent item flow diagrams.

INPUT	FUNCTION	OUTPUT
UV Control Data Threat Report Resource Requirements Limiting Constraints Higher Command Guidance Friendly Force Report Environmental Report	1 Provide C2	C2 Information Mission Tasking Resource Orders UV Control Order
Threat Report Resource Requirements Limiting Constraints Higher Command Guidance Friendly Force Report Environmental Report	1.1 Observe	Observed Reports consisting of: Observed Threat Report Observed Resource Requirements Observed Limiting Constraints Observed Higher Command Guidance Observed Friendly Force Report Observed Environmental Report
Threat Report Resource Requirements Limiting Constraints Higher Command Guidance Friendly Force Report Environmental Report	1.1.1 Monitor Situation	Observed Threat Report Observed Resource Requirements Observed Limiting Constraints Observed Higher Command Guidance Observed Friendly Force Report Observed Environmental Report
Resource Requirements Friendly Force Report	1.1.1.1 Monitor Internal Environment	Observed Resource Requirements Observed Friendly Force Report
Threat Report Limiting Constraints Higher Command Guidance Environment Report	1.1.1.2 Monitor External Environment	Observed Threat Report Observed Limiting Constraints Observed Higher Command Guidance Observed Environmental Report
Observed Reports	1.2 Orient	Force Picture Mission Gap Picture
Observed Reports	1.2.1 Understand Situation	Environment Picture Force Picture Threat Picture
Observed Resource Requirements Observed Friendly Force Report Observed Limiting Constraints Observed Higher Command Guidance Observed Communication Status Observed Asset Availability	1.2.1.1 Assess Friendly Capability	Force Picture
Observed Threat Report	1.2.1.2 Assess Threat	Threat Picture
Observed Environmental Report	1.2.1.3 Analyze Environment	Environmental Picture
Threat Picture	1.2.2 Identify Mission Success	Mission Gap Picture

Force Picture Environment Picture	Gap	
Mission Gap Picture	1.3 Decide	Selected COA
Mission Gap Picture	1.3.1 Determine COA	Selected COA
Mission Gap Picture	1.3.1.1 Develop COAs	COAs
COAs	1.3.1.2 Analyze COAs	Analyzed COAs
Analyzed COAs	1.3.1.2.1 Assess Risk	Risk Assessed COAs
Risk Assessed COAs	1.3.1.2.2 Analyze Timing	Analyzed COAs
Analyzed COAs	1.3.1.3 Select COA	Selected COA
Selected COA UV Control Data (Telemetry) Force Picture	1.4 Act	Mission Tasking UV Control Orders Resource Orders
UV Control Data (Telemetry) Selected COA Force Picture	1.4.1 Command Assets	UV Control Order Mission Tasking Resource Orders
Selected COA	1.4.1.1 Assign Mission	Mission Tasking
UV Control Data (Telemetry)	1.4.1.2 Direct UVs	UV Control Order
Force Picture	1.4.1.3 Provide Resources	Resource Orders
Selected COA Observed Reports Mission Gap Picture Force Picture Mission Tasking Resource Orders	1.5 Share To Network	C2 Information

TABLE 17. PROVIDE C2 INPUT/OUTPUT.

The next several figures, [Figures 39.](#) through [Figure 46.](#), depict the information flows of the sub functions of Provide C2. These diagrams are intended to present a visual representation with corresponding discussion of the information found in [Table 17.](#)

[Figure 39.](#) shows the information flow for the Monitor Situation, which is a sub function of Observe. Monitor Situation is decomposed by Monitor Internal Factors and Monitor External Factors. The inputs to Monitor Internal Factors are Friendly Force Report and Resource Requirements. The Friendly Force Report is an organized report specifying the operational capability of the forces assigned to a particular commander. This report can specify different levels of force readiness, such as forces available for a specific tactical engagement or an operational campaign. Resource Requirements is an organized display of the resources required by internal nodes of the system.

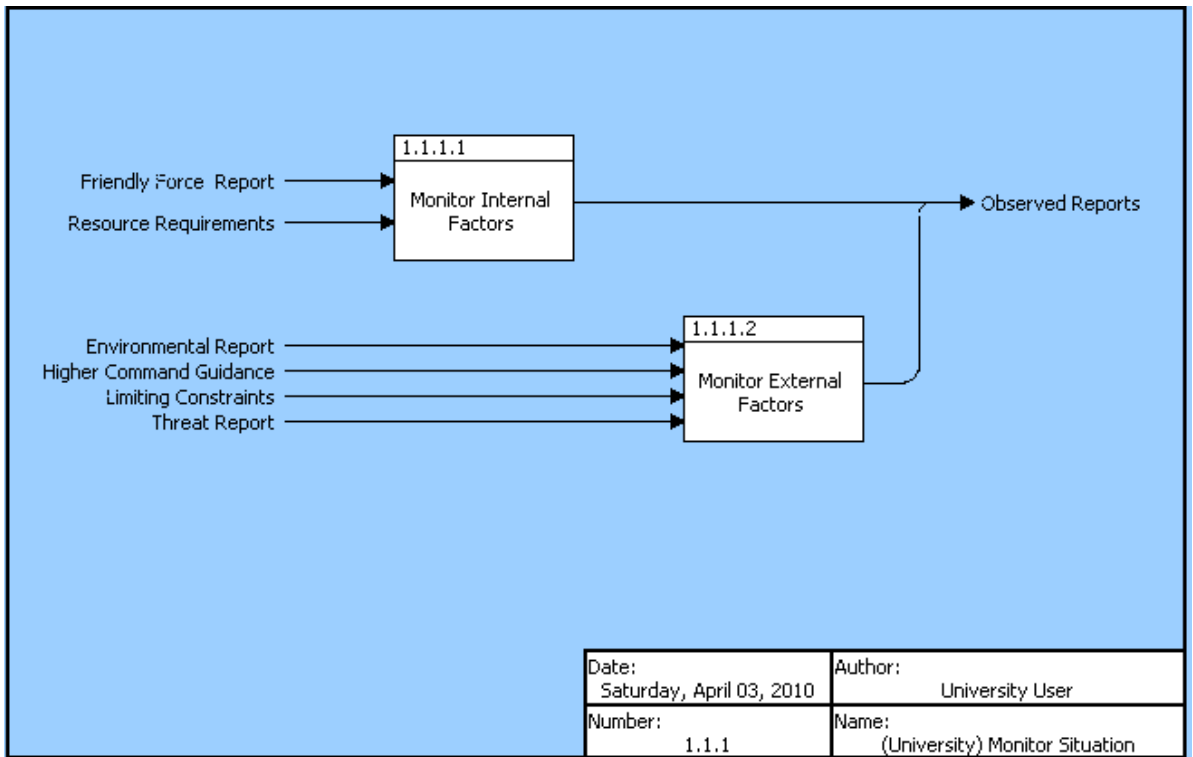

Figure 39. Monitor System Item Flow

The inputs to Monitor External Requirements are: Environmental Report, Higher Command Guidance, Limiting Constraints, and Threat Report. The Environmental Report is an organized report displaying data input to the Collaborative Network that specifies environmental parameters such as temperature, barometric pressure, wind speed, and level of humidity. Higher Command Guidance contains orders and direction input to the network from higher commands that alter the command and control of the systems. Limiting Constraints are an organized display of limitations to a particular course of action or operational configuration. Constraints include conditions that could hamper the C2 of UVs. For example, emissions control situations, electronic warfare threats, and kinetic threats from enemies. The Threat Report is an organized display of the threat or enemy. The report details the nature of the threat such as the platform type, number of enemy forces, weapon system characteristics, any hostile actions, and tracking, targeting information.

The outputs of Monitor Internal Factors and Monitor External Factors are Observed Reports, which are reports that have been filtered by the network in the Manage Data function and are now observed in a manner that facilitates comprehension in the least amount of time possible. Observed Reports is an overarching term that represents: Observed Friendly Force Report, Observed Resource Requirements, Observed Environmental Report, Observed Higher Command Guidance, Observed Limiting Constraints, and Observed Threat Report. Each of these Observed Reports are vital inputs to the Orient function.

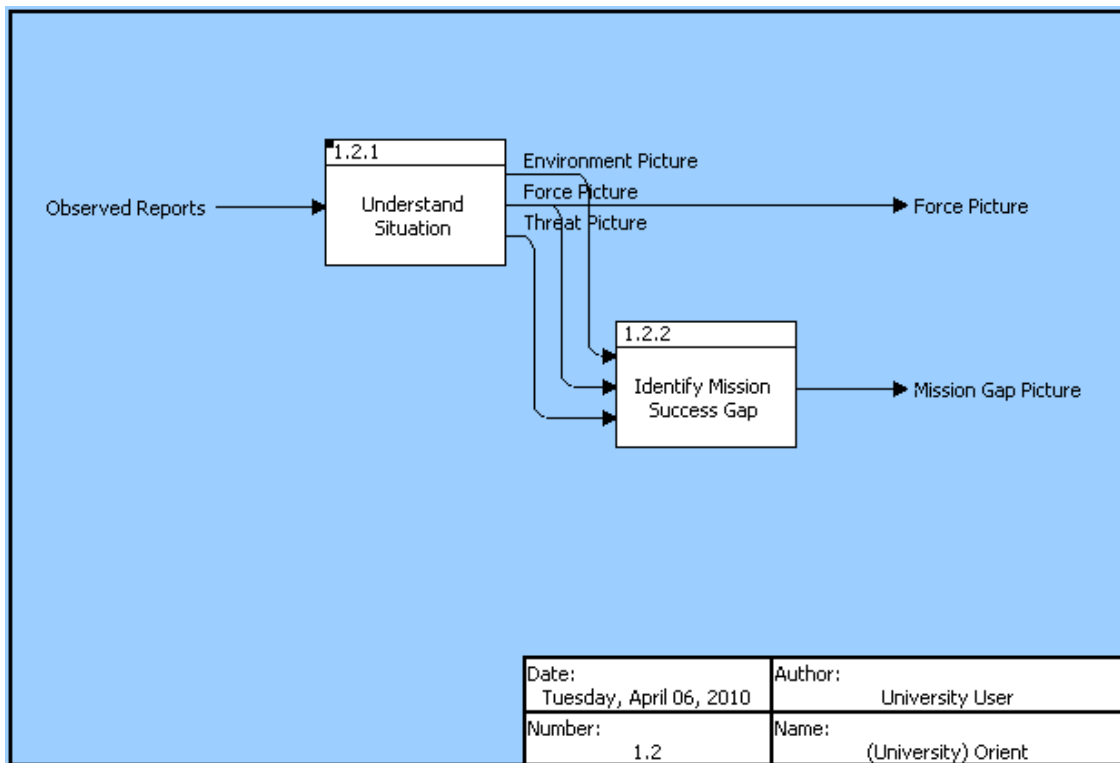

Figure 40. Orient Item Flow

[Figure 40.](#) details the item flow to Orient. Orient is broken down to two sub functions, Understand Situation and Identify Mission Success Gap. Understand the Situation is broken down into its sub functions and analyzed in more detail in [Figure 41.](#) The inputs to Understand Situation are the Observed Reports as discussed in the previous discussion on Monitor the Situation’s Item Flow. The outputs from Understand Situation are: Environmental Picture, Force Picture, and Threat Picture. Environmental Picture is

a representation of the environmental situation, including parameters such as temperature, barometric pressure, wind speed, level of humidity, in a manner that allows follow on decision making. The Force Picture assimilates the Observed Friendly Force Report, Observed Higher Command Guidance, Observed Limiting Constraints, Observed Asset Availability, Observed Resource Requirements, and Observed Communication Status. The Force Picture provides the situation in a manner that allows follow on decision making. The Force Picture provides the situation in a manner that allows follow on decision making. The Force Picture is output to both Identify Mission Success Gap under the Orient function and to Command Assets under the Act function to assist the commander in directing forces. The Threat Picture is a representation of the threat that allows follow on decision making.

The outputs from Understand Situation are inputs to Identify Mission Success Gap. Identify Mission Success Gap's output is the Mission Gap Picture. The Mission Gap Picture is the result of the transformation of the Force Picture, Threat Picture, and Environmental Picture. The threat is compared against the friendly forces in a given environment. The desired state is also compared to what is actually occurring in the battlespace. The result is the indication of whether what is expected to be happening is actually occurring and is a key element of the Control aspect of C2.

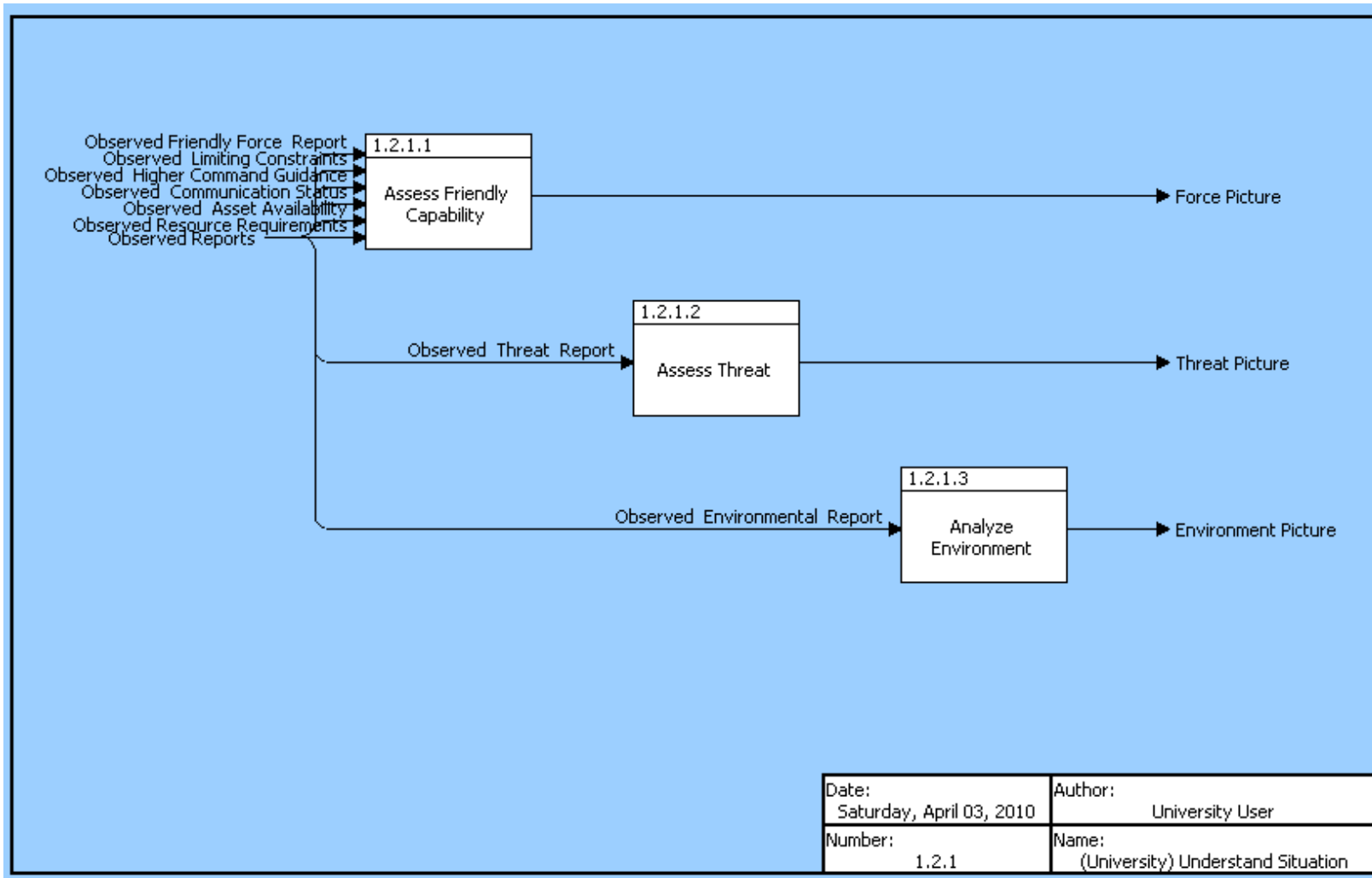

Figure 41. Understand Situation Item Flow

[Figure 41.](#) decomposes Understand Situation into the sub functions: Assess Friendly Capability, Assess Threat, and Analyze Environment. The inputs to Assess Friendly Capability are: Observed Friendly Force Report, Observed Limiting Constraints, Observed Command Guidance, Observed Communication Status, Observed Asset Availability, Observed Resource Requirements, and Observed Reports. As discussed in Monitor Situation's item flow ([Figure 39.](#)) discussion, the Observed Reports are reports that have been transformed in the Observe function. The output from Assess Friendly Capability is the Friendly Force Picture. The output from Assess Threat is the Threat Picture. The output from Analyze Environment is the Environmental Picture. The definitions of each of these outputs were described in Orient's item flow ([Figure 40.](#)) discussion.

[Figure 42.](#) shows Decide’s sub function, which is Determine COA. Determine the COA is further broken down and defined in [Figure 43.](#) The input to Decide is the Mission Gap Picture, which was an output from Orient. The Mission Gap Picture allows the determination of the COA by showing what areas to focus on. Upon completing the Decide function, a Selected COA is output from the Decide function. The Selected COA is the COA that the decision maker has chosen after weighing factors such as the gap between the desired state and the actual state, risk, and timing factors.

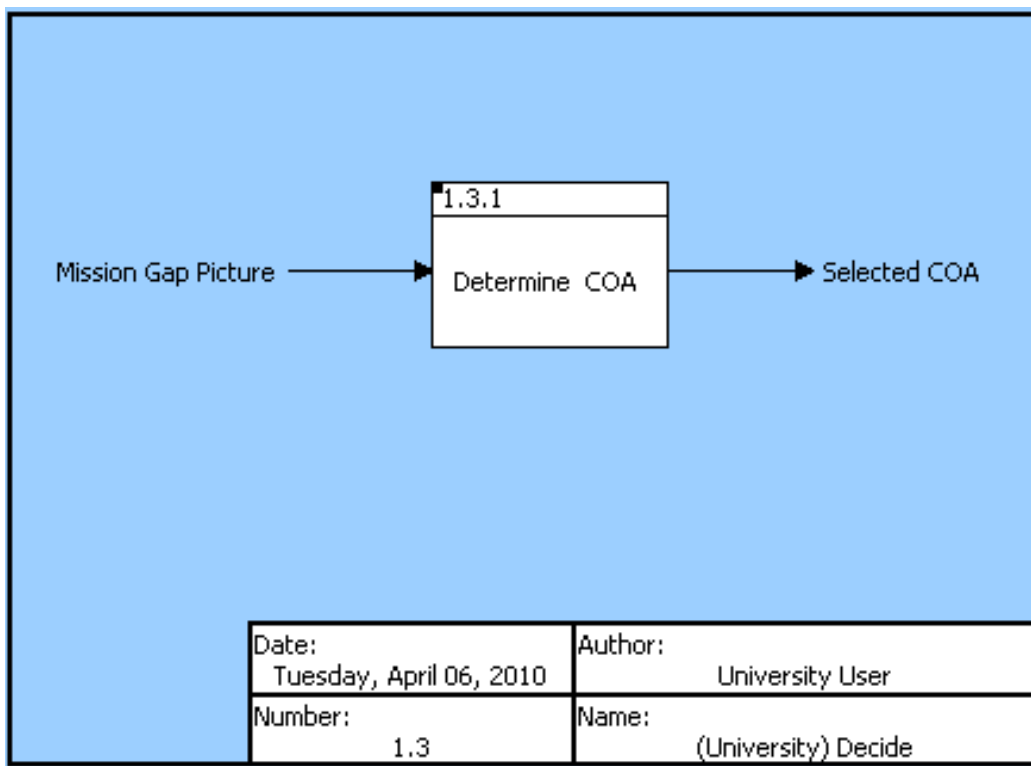

Figure 42. Decide Item Flow

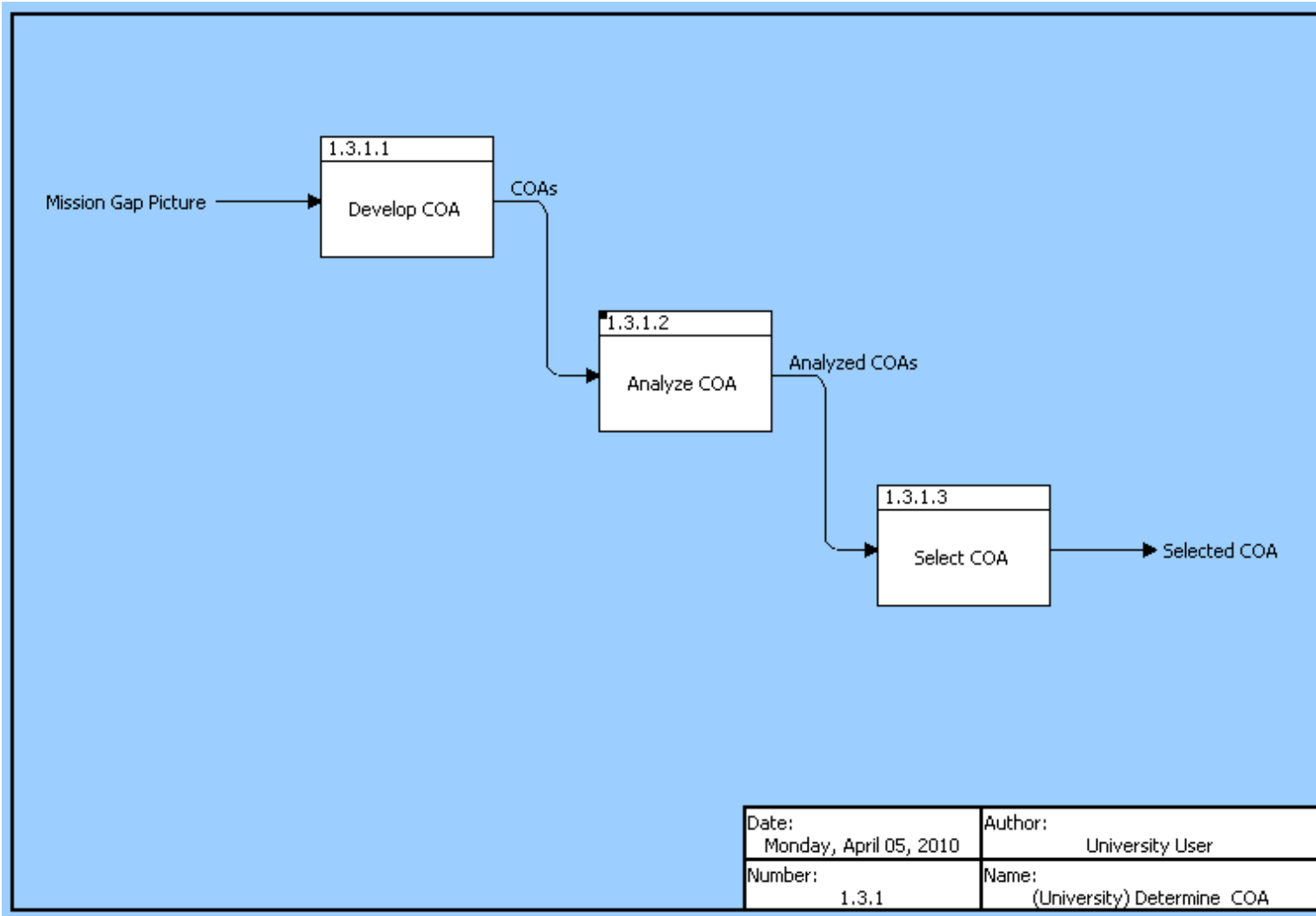

Figure 43. Determine COA Item Flow

[Figure 43.](#) shows the decomposition of Determine COA. Determine COA is decomposed by: Develop COA, Analyze COA, and Select COA. [Figure 44.](#) will further decompose Analyze COA. The input to Develop COA is the Mission Gap Picture which was discussed previously in [Figure 40.](#)'s discussion. Develop COA outputs are the different COAs that the commander developed to meet mission objectives. The candidate COAs are then input to Analyze COA, which takes the nominative COAs and weighing these COAs against the criteria of risk and timing. The outputs are the Analyzed COAs which are input to Select COA. In this function, a final COA is chosen which the commander feels will give the highest probability of success given the limitations and resources the commander is faced with. The output from Decide is the Selected COA which is the COA that the decision maker has chosen after weighing factors such as the gap between the desired state and the actual state, risk, and timing factors.

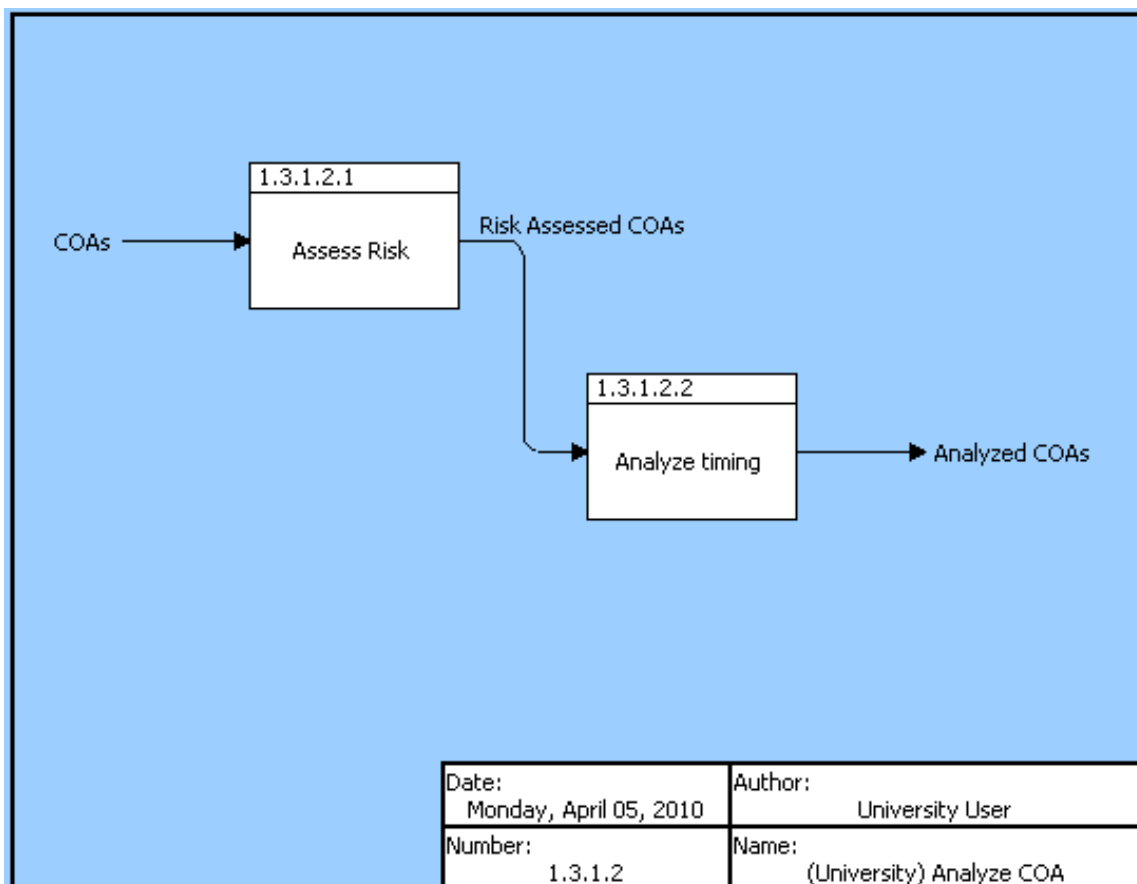

Figure 44. Analyze COA Item Flow.

[Figure 44.](#) is the decomposition of function Analyze COA. The inputs to this function are the candidate COAs which were generated in the Develop COA function. The COAs are risk assessed where possible enemy courses of action and reactions are taken into account. Also, such items as mission criteria, limitations, and time criticality were considered. The resulting outputs are the Risk Assessed COAs which are then specifically analyzed for timing considerations in the function Analyze Timing. During Analyze Timing, the commander assesses how fast a decision and action must be rendered. Less time critical events allow more analysis where time critical events require very rapid decision making and subsequent action. The resulting outputs are the Analyzed COAs as discussed in terms of risk and timing analysis in the discussion on [Figure 43.](#)

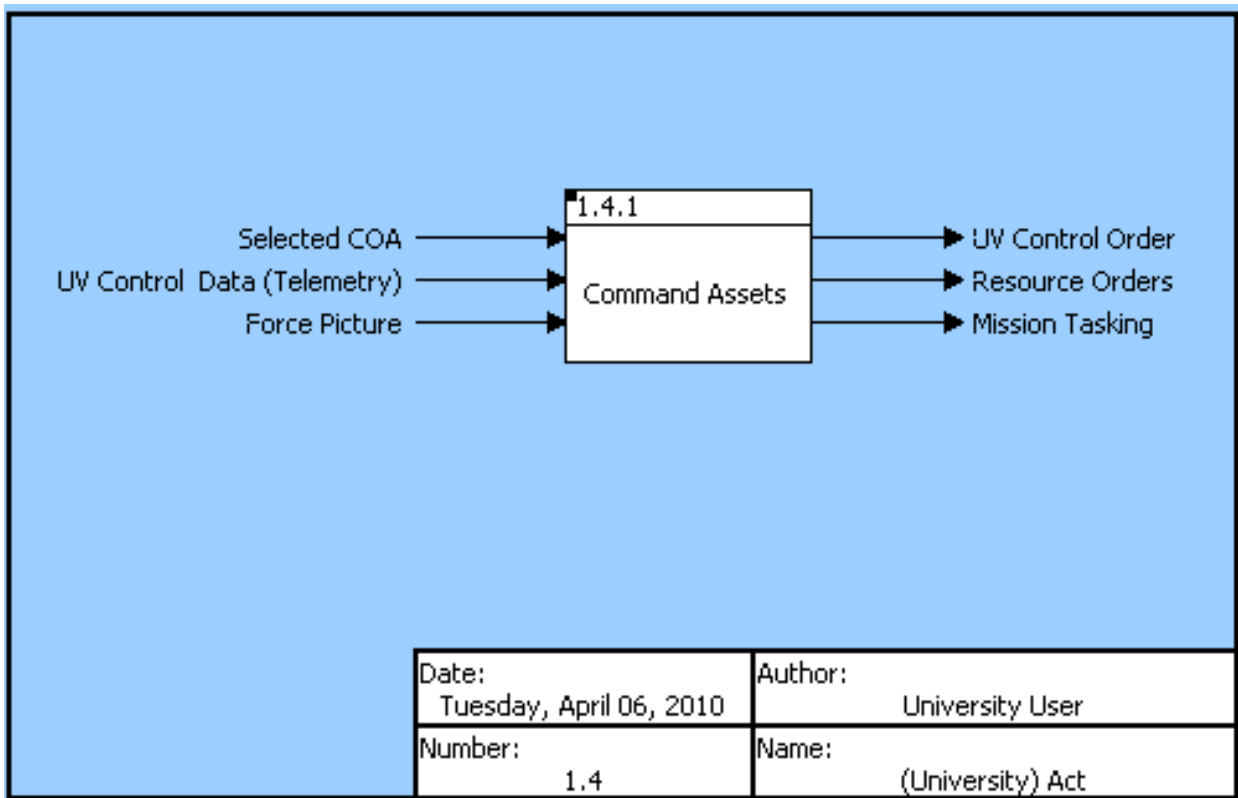

Figure 45. Act Item Flow

[Figure 45](#). shows the item flow for the Act function. Act is decomposed by the function Command Assets which are decomposed further in [Figure 46](#). The inputs to Command Assets are: Selected COA, UV Control Data (Telemetry) and the Force Picture. Selected COA is the chosen COA as discussed in [Figure 43](#).’s discussion. UV Control Data (Telemetry) is output from UVs operating in the environment and is the automatic measurement and transmission of unmanned vehicle data by wire, radio, or other means from remote sources, as from unmanned aerial vehicles, to receiving stations for recording, analysis, and control purposes. The Force Picture assimilates the observed friendly force report, observed higher command guidance, observed limiting constraints, observed asset availability, observed resource requirements, and observed communication status. The intent of the Force Picture is to enhance the director of the unmanned vehicles situational awareness.

The outputs from Command Assets are UV Control Orders, Resource Orders, and Mission Tasking. UV Control Orders are an order given by the C2 network indicating a particular action to be taken by a UV. The level of control data will vary from a mission update to an autonomous UV to more consistent stream of control orders to less autonomous UVs. Resource orders are orders which provide resources operating assets. An example of a resource order would be to direct a refueling asset to refuel a UAV or direct another UAV to replace a UAV needing to leave a surveillance post. Mission Tasking is the issuing of the selected course of action and associated orders to a particular node. For example, C2 may order a UUV to detonate an identified underwater mine, or other similar task.

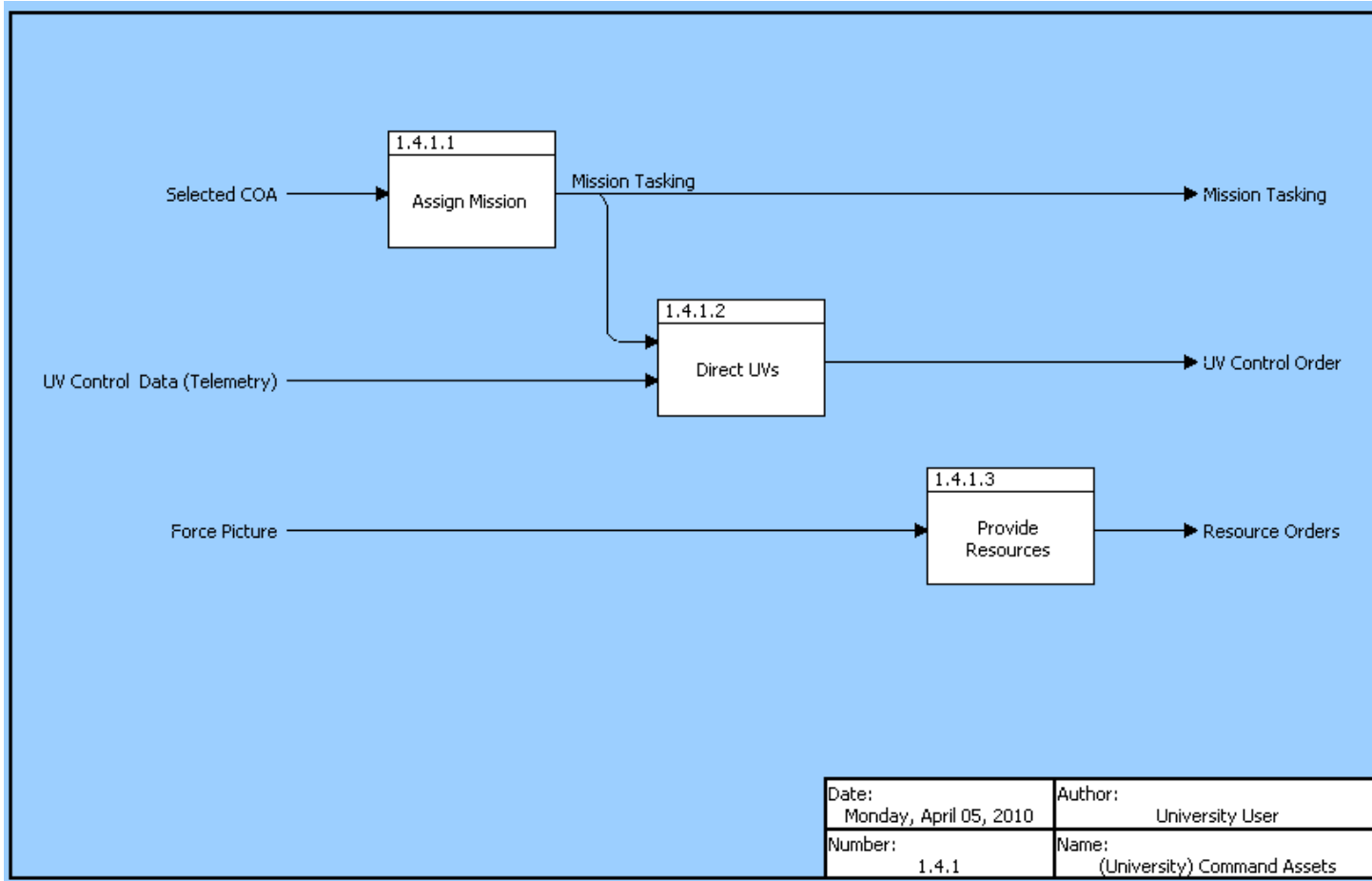

Figure 46. Command Asset Item Flow

[Figure 46.](#) is the decomposition of Command Assets. Command Assets is broken down into Assign Mission, Direct UVs, and Provide Resources. The definitions of these sub functions are found in the discussion under [Figure 43.](#)'s discussion. The input and output definitions are the same as discussed under [Figure 45.](#)'s discussion.

4.1.3.3. Collaborate

Collaboration is vital to achieving a shared situational awareness. Below are the architectural products of the function Collaborate. [Figure 47.](#) illustrates the hierarchical structure and [Figure 48.](#) depicts the functional flow. [Table 18,](#) [Figure 49.](#) and [Figure 50.](#) represent the input/output of each function.

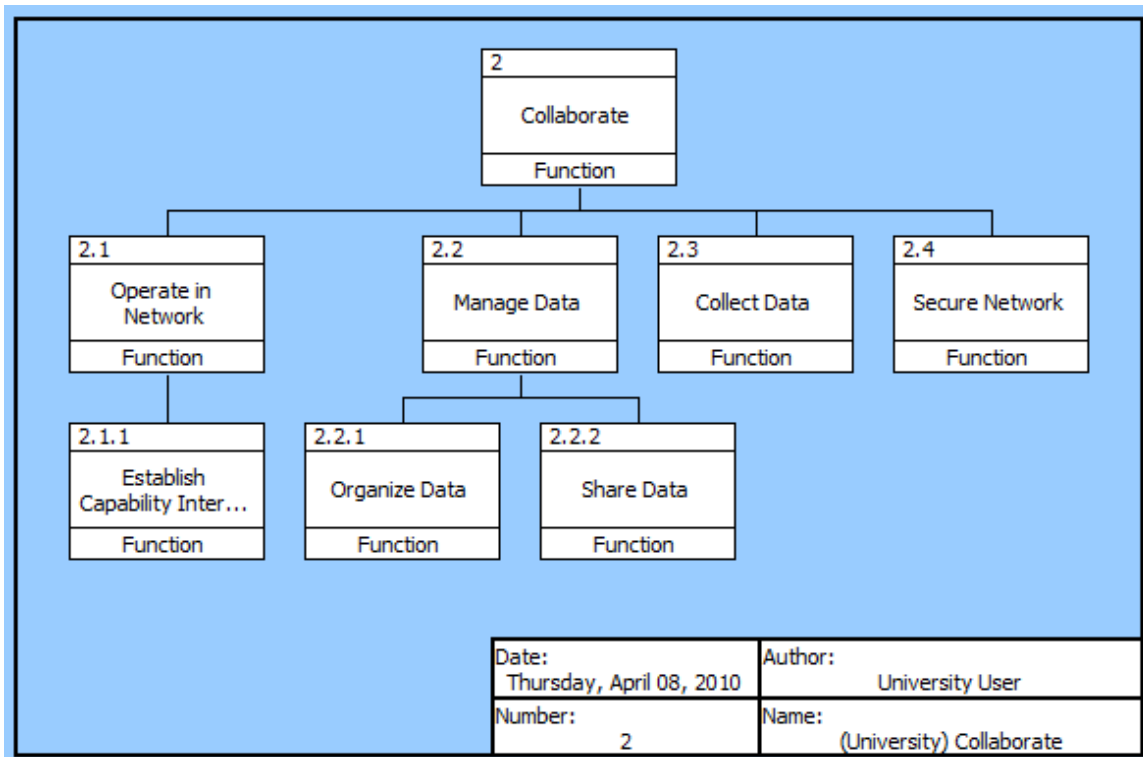

Figure 47. Collaborate Hierarchy

[Figure 47.](#) is the functional decomposition of Collaborate. Collaborate is decomposed into four functions: Operate in Network, Manage Data, Collect Data, and Secure Network.

Operate in Network is the ability to exploit all human and technical elements of the force and its mission partners by fully integrating collected information, experience, knowledge, and decision making via a collaborative network.¹⁰⁷ Data and information are securely shared via the network, enhancing each individual node's awareness. The network will connect all nodes including UVs that conduct operations, manned assets and C2 nodes that provide the Command and Control to operational assets. The goal is a seamless integration between manned and unmanned assets across all domains with the appropriate C2 node. Operate in Network is further broken down to Establish Capability Interface. Establish Capability Interface is the sharing of needed operational information when information is entered via a user capability interface or through a sensor transduction capability interface.

Manage Data ensures, given information, that decision makers have ready access to the information they want and need while minimizing the risk of information overload. Manage Data is decomposed into two sub functions: Organize Data and Share Data. Organize Data is the filtering, prioritizing, and manipulating to present observable reports. The goal is to present information to C2 nodes that is useful and manageable, not overwhelming. Share data is the uploading of information to a collaborative network in order to increase each internal operational node's understanding of the situation and also to inform external stakeholders that interface with the network.

Collect data is the receiving of information from all necessary internal system nodes such as UVs, manned vehicles, and C2 centers, as well as required data from external agencies.

Secure network is the function which ensures information assurance. Information in the operational nodes and network must be protected from information attacks by hackers and enemies.

¹⁰⁷ U.S. Department of Defense, Joint Publication 1-02, *DOD Dictionary of Military and Associated Terms*, October 2009.

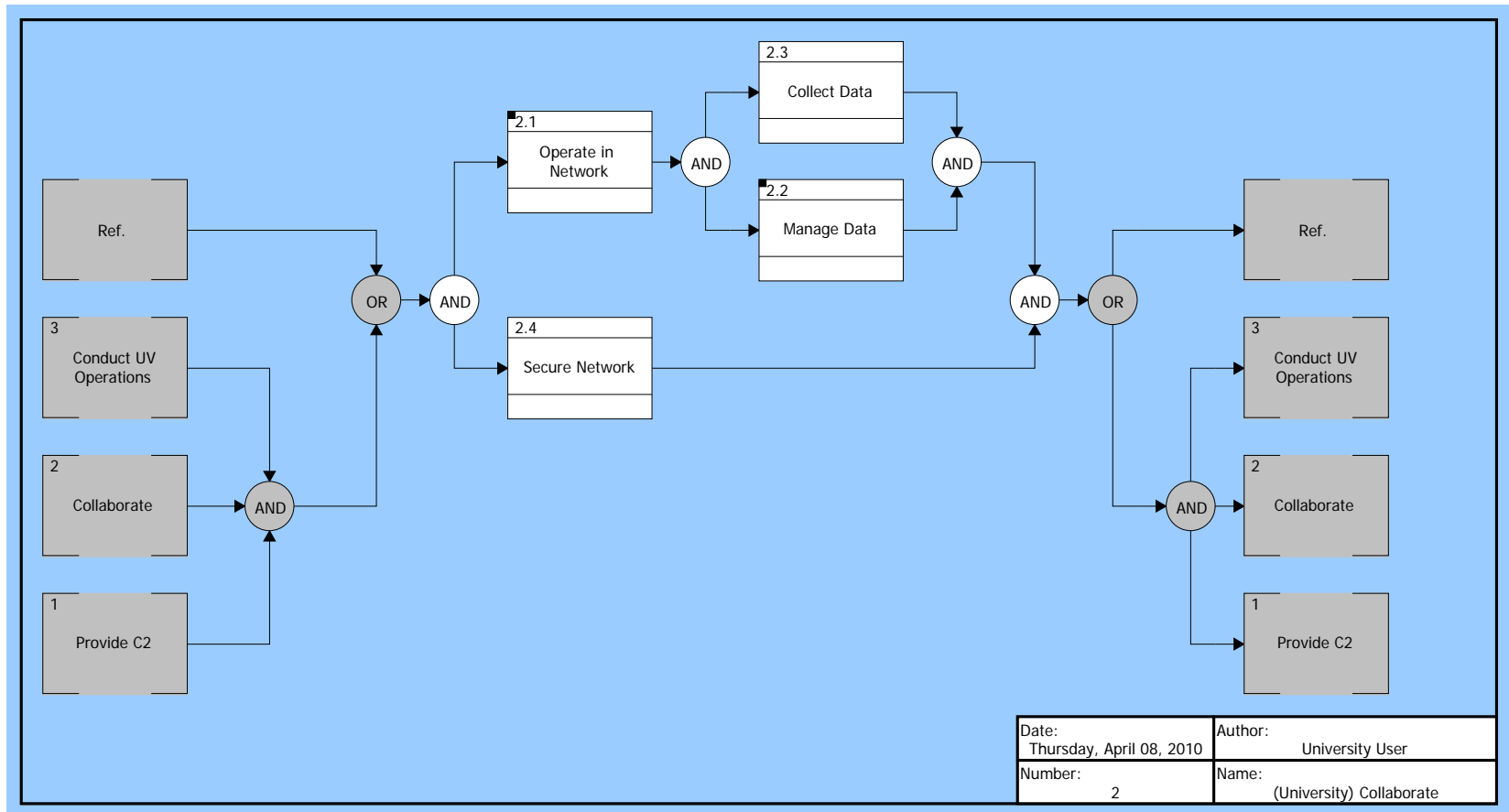

Figure 48. Collaborate FFBD

[Figure 48.](#) is the FFBD for Collaborate. The figure illustrates that Operate in Network occurs concurrently with Secure Network. The network must be secured at all times while the system is in operation. The figure also shows that Collect Data and Manage Data occur in parallel. The system must be able to receive data and filter data at the same time.

[Table 18](#) provides a tabular representation of the inputs to and outputs from Collaborate. This table will assist the understanding of the subsequent item flow diagrams.

INPUT	FUNCTION	OUTPUT
Join Network Requests Information Requests UV Status/Location Resources Available Higher Command Data Operational Constraints Communication Errors Asset Availability Communication Status C2 Information Shared Sensor Picture	2 Collaborate	Join Network Confirmations Information Transmittal Environmental Report Friendly Force Report Higher Command Guidance Limiting Constraints Threat Report Resource Requirements
Join Network Requests	2.1 Operate In Network	Join Network Confirmations
Join Network Requests	2.1.1 Establish Capability Interface	Join Network Confirmations
Secured Data Information Requests	2.2 Manage Data	Environmental Reports Friendly Force Report Higher Command Data Information Transmittal Limiting Constraints Resource Requirements Threat Report
Secured Data	2.2.1 Organize Data	Organized Data
Organized Data Information Requests	2.2.2 Share Data	Environmental Reports Friendly Force Report Higher Command Guidance Informational Transmittal Limiting Constraints Resource Requirements Threat Report
UV Status Shared Sensor Picture Resources Available Operational Constraints Higher Command Data Communication Status Communication Errors C2 Information Asset Availability	2.3 Collect Data	Collected Data
Collected Data	2.4 Secure Network	Secured Data

TABLE 18. COLLABORATE INPUT/OUTPUT.

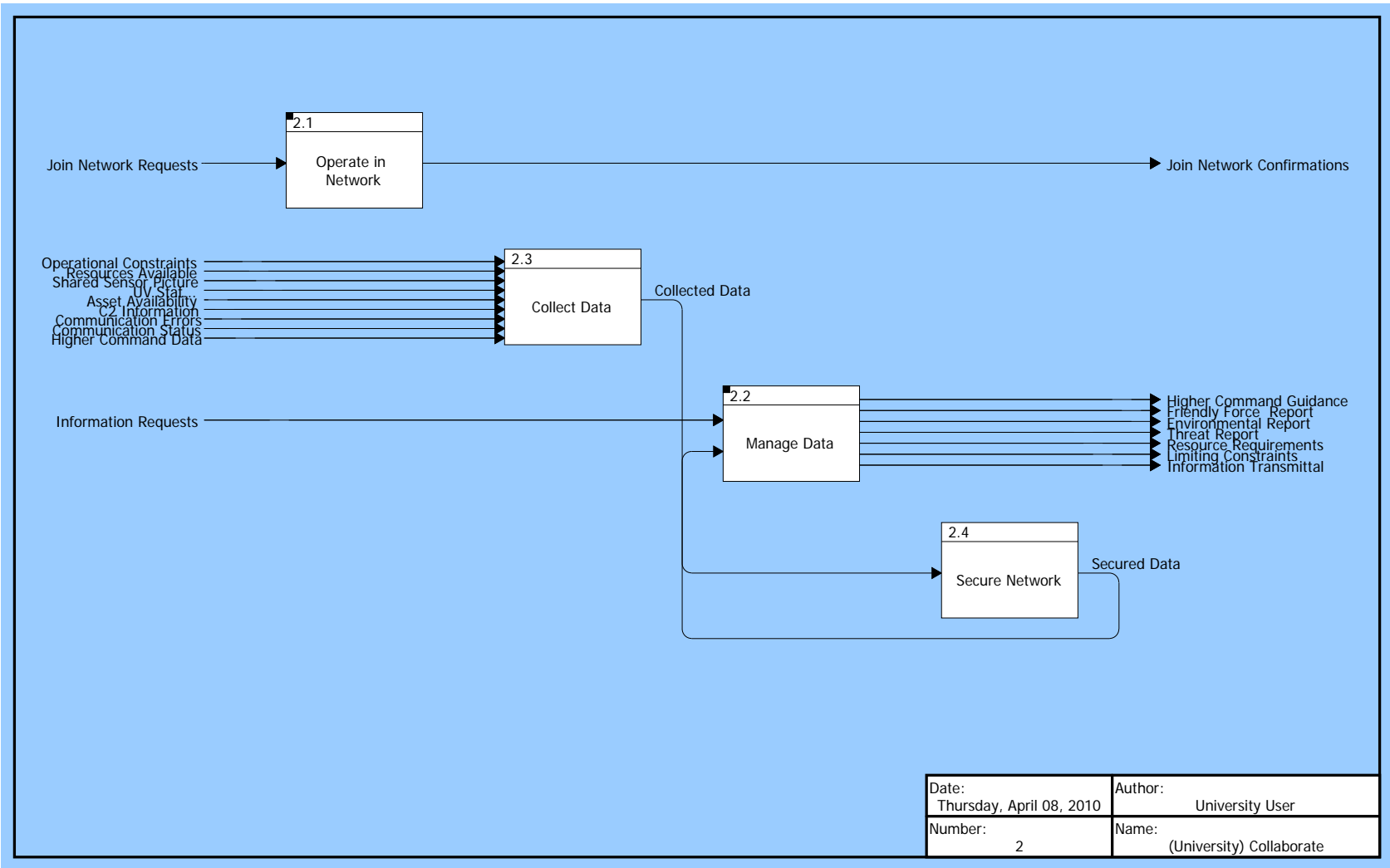

Figure 49. Collaborate Item Flow

[Figure 49](#). displays the item flow for the Collaborate function. The first point of discussion are the two inputs that do not go directly to collect data. Join Network Requests are requests made by external nodes to interface with the network. The requests are processed in the function Operate in Network through the sub function Establish Capability Interface. If the request is verified and approved, the function outputs Join Network Confirmations. Information Requests are specific requests by entities that have established an interface for information contained in the network. The request is processed by the Manage Data function where the request is processed and a request is sent via the output Information Transmittal.

The majority of the inputs to the system flow into the Collect Data function. The inputs to Collect Data are: Operational Constraints, Resources Available, Shared Sensor Picture, UV Status/Location, Asset Availability, C2 Information, Communication Errors, Communication Status, and Higher Command Data. Operational constraints include conditions that could hamper the C2 of UVs and manned assets. For example, emission control conditions, electronic warfare threats, air space management considerations, natural disaster considerations, and others. Resources Available is data specifying resources available for operations. For example, how much fuel is available to sustain UVs for a particular operation? How many reserve UVs are available given casualties to UVs in the AO? Shared Sensor Picture is sensor data that has been fused by the master UV and then shared to the C2 network. A manned asset can also send sensor data. The sensors could include any relevant mix such as IR, Optical, Radar, Synthetic Aperture Radar, or Acoustic. UV Status/Location is the data detailing where a UV is operating, where it can be available to operate, and where it is in terms of tasking completion. Similar data is collected for manned assets operating in the environment. Asset Availability is an organized report specifying which UV's and other assets such as manned vehicles are available for specific mission. C2 Information is information shared by C2 nodes from each stage of the OODA process in order to maximize the collaborative efforts of the network. Communication Errors are failures in the communications between nodes in the system. For example, this data would indicate a loss of communications to a UV. The Communication Status is an organized report

specifying whether or not a UV or other communication asset has positive communication. Higher Command Data orders and guidance sent by a command outside of the Collaborative Network.

The output from the Collect function is summarized by Collected Data, which is all the data that is collected by the Collect function. This Collected Data is input to the function Secure Network where the data is protected from exploitation by hackers and other enemies. The Secured Data is then sent to Manage Data. Manage Data transforms the Secured Data into several outputs including: Higher Command Guidance, Friendly Force Report, Environmental Report, Threat Report, Resource Requirements, Limiting Constraints, and Information Transmittals. All of these outputs, except for Information Transmittals, are inputs to the Observe function and were described in the description of [Figure 40](#). Information Transmittals were described earlier in this description of [Figure 49](#).

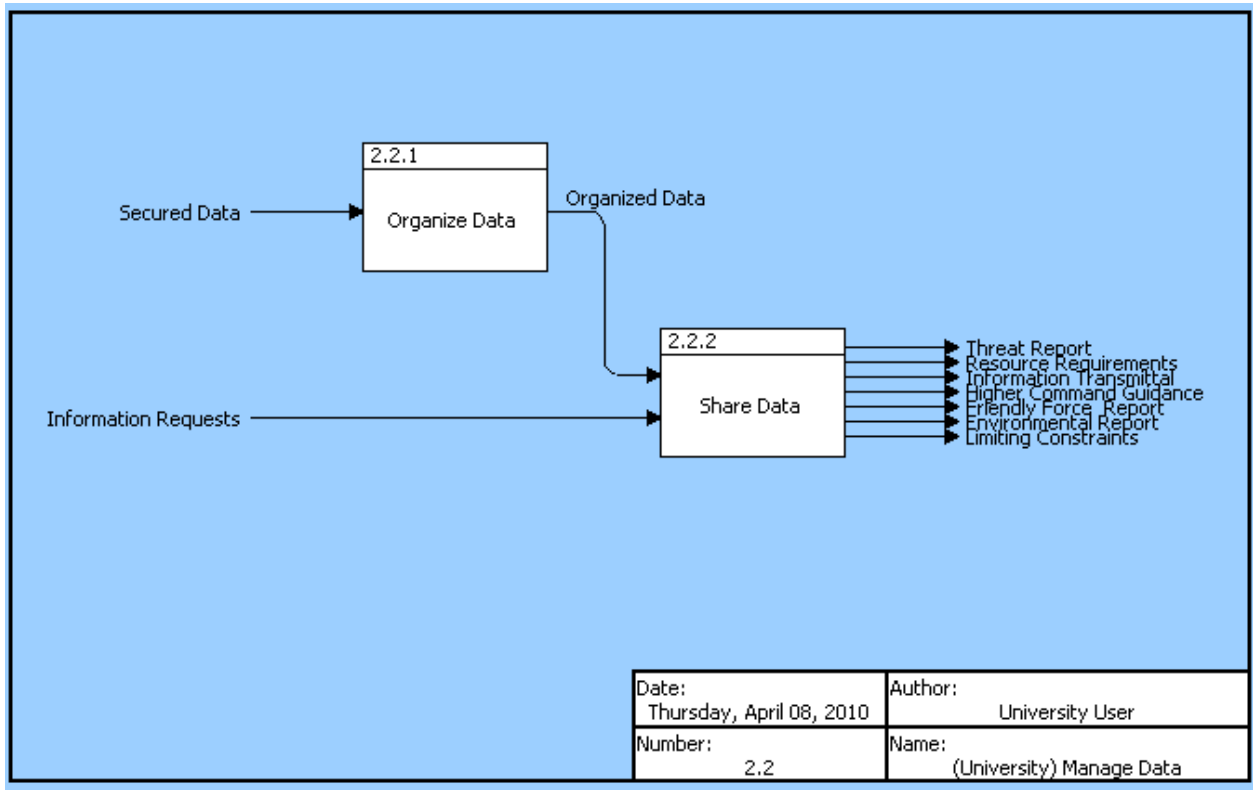

Figure 50. Manage Data Item Flow

[Figure 50.](#) is the item flow illustration for the functions which decompose Manage Data. All of the inputs and outputs have been discussed previously with the exception of the output Organized Data. Organized Data is the data which has been filtered, prioritized, and manipulated into an observable and understandable form. The goal of the Organized Data is to present information to C2 nodes that is useful and manageable, not overwhelming. Share data is the uploading of information to a collaborative network in order to increase each internal operational node's understanding of the situation and also to inform external stakeholders that interface with the network.

4.1.3.4. Conduct UV Operations

Conduct UV Operations entails the mission accomplishment that is carried out by unmanned vehicles and other assets in the battlespace, such as manned vehicles. This functional breakdown will focus on the UVs, however, the information exchange between UVs and manned vehicles is a critical component and are discussed in more detail in [Section 4.2.](#) The concept of operations envisions the UVs as operating with one UV as a “Master” and the other UVs as the “Subordinates.” The master UV communicates with the subordinate UVs and also communicates with the Collaborative Network. Each UV can assume the role as master if the current master is unable to perform the role. The “Master” and “Subordinate” role is discussed in more detail in [Section 4.2.](#)

Below are the architectural products for the function Conduct UV Operations. [Figure 51.](#) will shows the hierarchy, [Figure 52.](#) shows the functional flow. [Table 19](#) and [Figure 53.](#) through [Figure 55.](#) will show the input/output of each function.

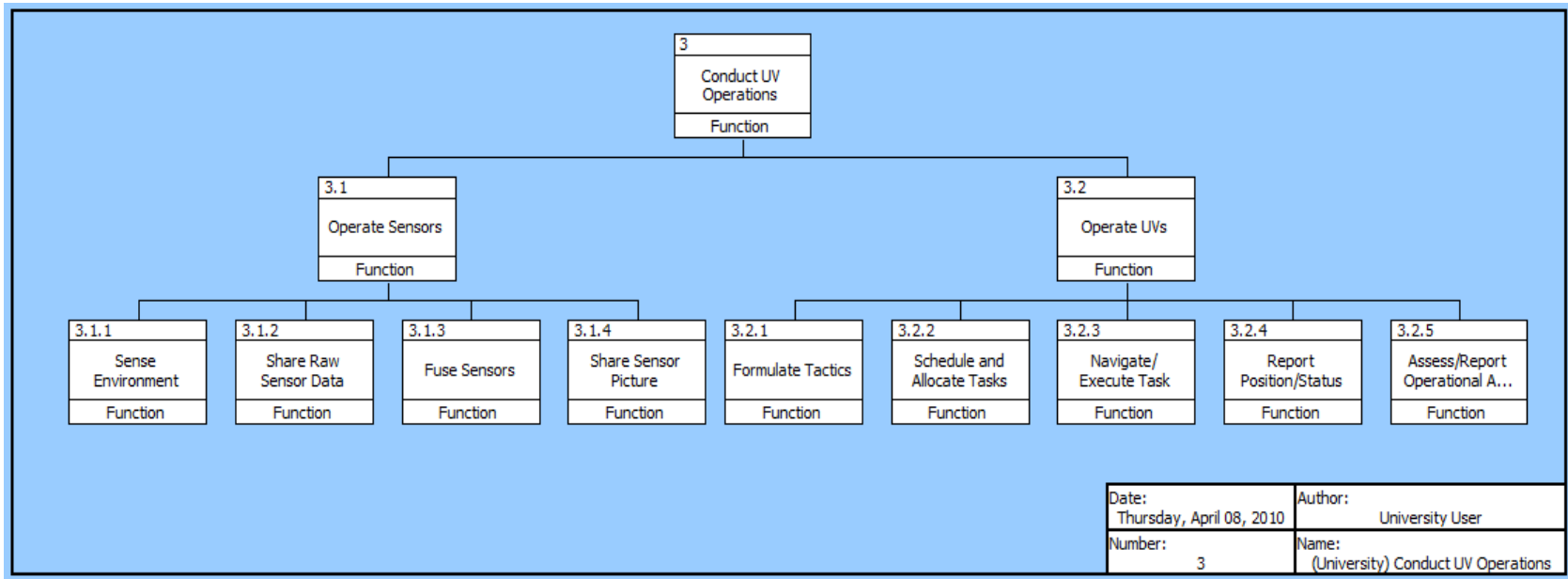

Figure 51. Conduct UV Operations Hierarchy

[Figure 51.](#) shows the functional decomposition of Conduct UV Operations. This function is broken down to two primary sub functions, Operate Sensors and Operate UVs.

Operate Sensors is the utilization of sensors onboard UVs, such as optical, infrared, acoustic, weather reading, RADAR, temperature, other sensors that are utilized by vehicles. Operate Sensors is decomposed by: Sense Environment, Share Raw Sensor Data, Fuse Sensors, and Share Sensor Picture. Sense Environment is the identifying, reading, and exploiting of observables in the environment. Observables could be vibrations, electromagnetic radiation, acoustic waves, and many other forms of stimuli. Share Raw Sensor Data is the sending of sensor data to other vehicles in the vicinity for greater situational awareness amongst operational nodes. These other vehicles could be other UVs or manned vehicles. Fuse Sensors is the combining of many different sensor feeds to create a situational picture or sensor picture. For example, an optical feed of a target from a UV could be correlated to an acoustic or RADAR target from a UV or manned vehicle, thereby giving the type of target, and the course and speed of target.

Share Sensor Picture is the communication of the fused sensor picture to the collaborative network and other vehicles. The objective of the Operate Sensors and its sub functions is to create a shared awareness of the operational environment that can be acted upon.

Operate UVs is the performance of operational activities by UVs in the battlespace. Activities include navigation, planning, task execution, and reporting. Operate UVs is decomposed to: Formulate Tactics, Schedule and Allocate Tasks, Navigate and Execute Tasks, Report Position Status, and Assess and Report Operational Availability. Formulate Tactics utilizes the artificial intelligence capabilities of UVs, the sensor picture from UVs, and inputs from C2 nodes, to formulate a tactical plan. The tactical plan includes maneuver information, sensor usage, weapon usage, and other relevant tactical tasks for a given situation. Schedule and Allocate Tasks is, given a tactical plan, the determination of specific tasks required to accomplish the plan. The tasks are scheduled and allocated to different assets. Navigate and Execute Tasks is the

actual maneuvering in a given environment and the carrying out of tasks such as surveillance. Report Position Status is the sharing to the collaborative network and required operational assets updates on position and task status. This provides situational awareness to the nodes in the network. Assess and Report Operational Availability is the identification of potential problems with the UVs and other equipment and asset that may hinder operational availability. These functions accomplish the required missions and feed the situational awareness of the network.

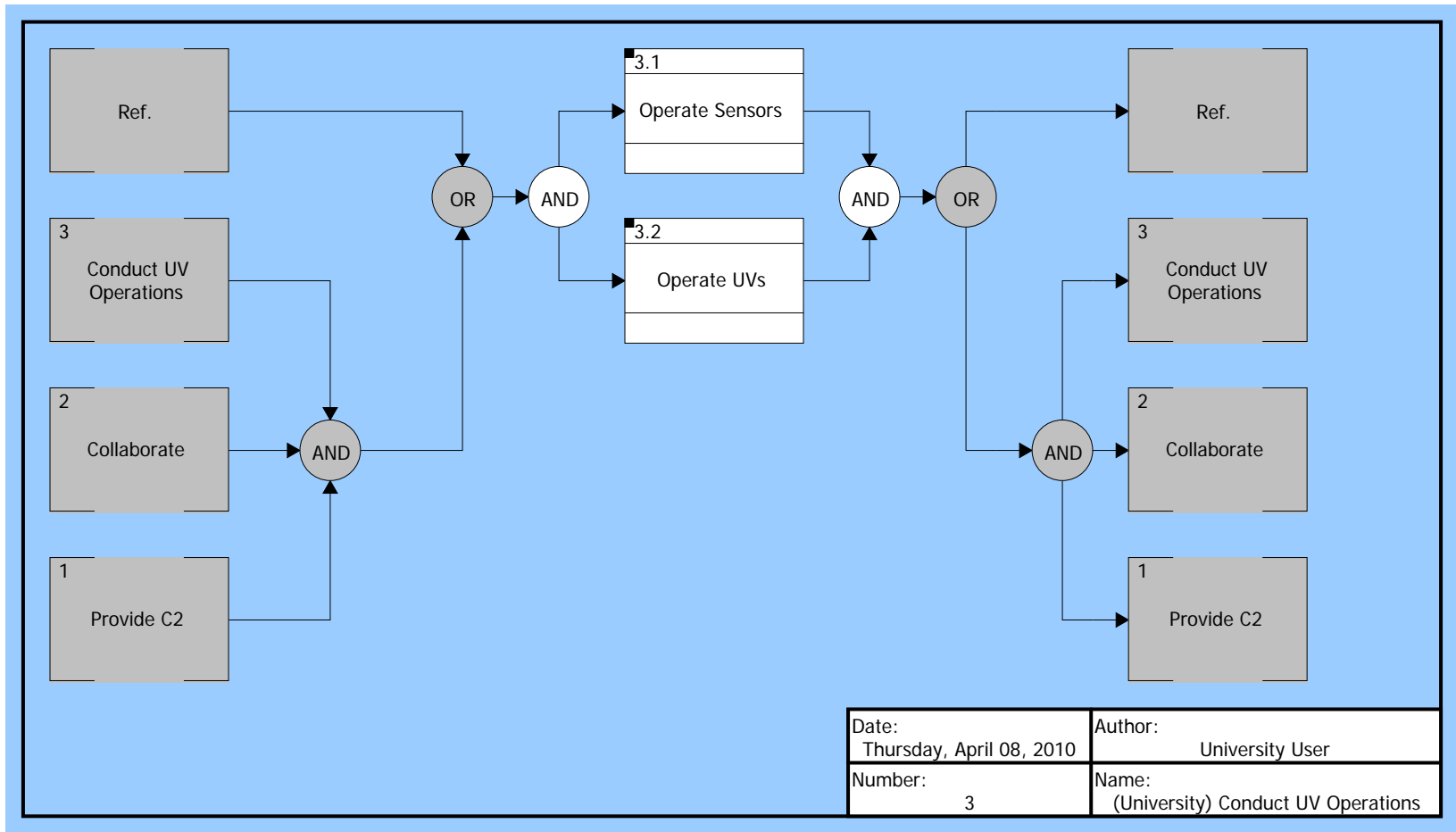

Figure 52. Conduct UV Operations FFBD

[Figure 52.](#) illustrates that functions Operate Sensors and Operate UVs occur in parallel. The sensor suites could be collocated with the UV, thus both functions will occur concurrently. In order to operate UVs to conduct military missions, the use of sensors are almost always required. For example, a UV conducting a surveillance mission sends sensor data such as video feeds to required C2 nodes.

[Table 19](#) provides a tabular representation of the inputs to and outputs from Conduct UV Operations. This table will assist the understanding of the subsequent item flow diagrams.

INPUT	FUNCTION	OUTPUT
UV Control Order Resource Orders Observables Mission Tasking	3 Conduct UV Operations	Asset Availability Communication Errors Communication Status Resources Available Shared Sensor Picture UV Control Data (Telemetry) UV Status/Location
Observables	3.1 Operate Sensors	Shared Sensor Data Shared Sensor Picture
Observables	3.1.1 Sense Environment	Sensor Data
Sensor Data	3.1.2 Share Raw Sensor Data	Shared Sensor Data
Sensor Data	3.1.3 Fuse Sensors	Sensor Picture
Sensor Picture	3.1.4 Share Sensor Picture	Shared Sensor Picture
UV Control Order Shared Sensor Picture Shared Sensor Data Resource Orders Mission Tasking	3.2 Operate UVs	Asset Availability Communication Errors Communication Status Resources Availability UV Control Data UV Status/Location
UV Control Order Shared Sensor Picture Shared Sensor Data Resource Orders Mission Tasking	3.2.1 Formulate Tactics	UV Tactical Plan
UV Tactical Plan	3.2.2 Schedule and Allocate Tasks	Tasking Order
UV Control Order Tasking Order	3.2.3 Navigate/Execute Task	UV Navigation/Task Status
UV Navigation Task Status	3.2.4 Report Position/Status	UV Control Data (Telemetry) UV Status/Location UV System Data
UV System Data	3.2.5 Assess Report Operational Availability	Asset Availability Communication Errors Communication Status Resources Available

TABLE 19. CONDUCT UV OPERATIONS INPUT/OUTPUT.

[Figure 53](#). illustrates the information item flow into and out of the sub functions of Conduct UV Operations. Observables are input to Operate Sensors. Observables could be vibrations, electromagnetic radiation, acoustic waves, and many other stimuli. These stimuli are sensed by UVs and this data is relayed to other UVs or manned vehicles as Shared Sensor Data. Shared Sensor Data and Shared Sensor Picture are outputs of Operate Sensors. Shared Sensor Data is sensor data that is transmitted from one vehicle to other vehicles in order to enhance situational awareness. Shared Sensor Picture is sensor data that has been fused by the Master UV and then shared to the C2 network.

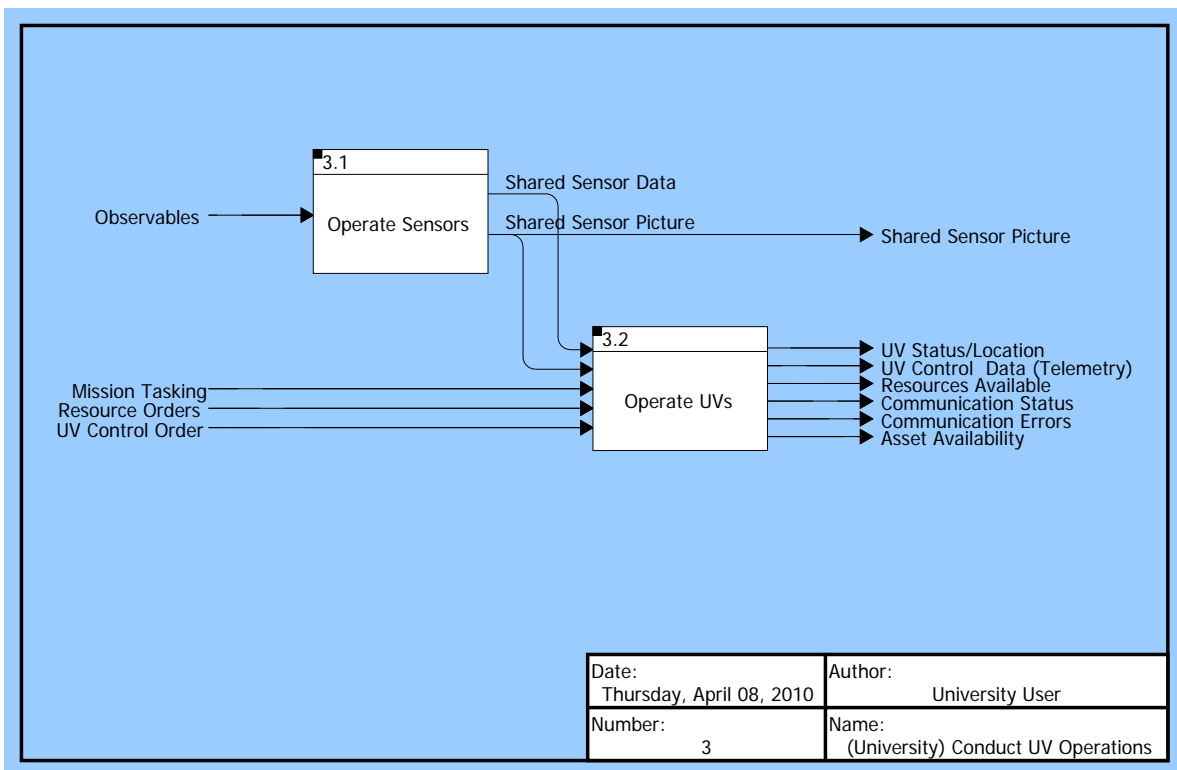

Figure 53. Conduct UV Operations Item Flow

The inputs to Operate UVs are Mission Tasking, Resource Orders, and UV Control Orders, as well as the previously mentioned Sensor Data. Mission Tasking is an input from a C2 node. Mission tasking is direction specifying the selected course of action and associated orders to a particular node. Resource Orders required assets, fuel,

and support as dictated by the operational environment, friendly capability, and time criticality. UV control orders are orders given by the C2 node indicating a particular action to be taken by a UV. The level of control data will vary from a mission update to an autonomous UV to more consistent stream of control orders to less autonomous UVs.

The outputs of Operate UVs were defined in [Figure 49](#)'s discussion of the Collaborative Network item flow.

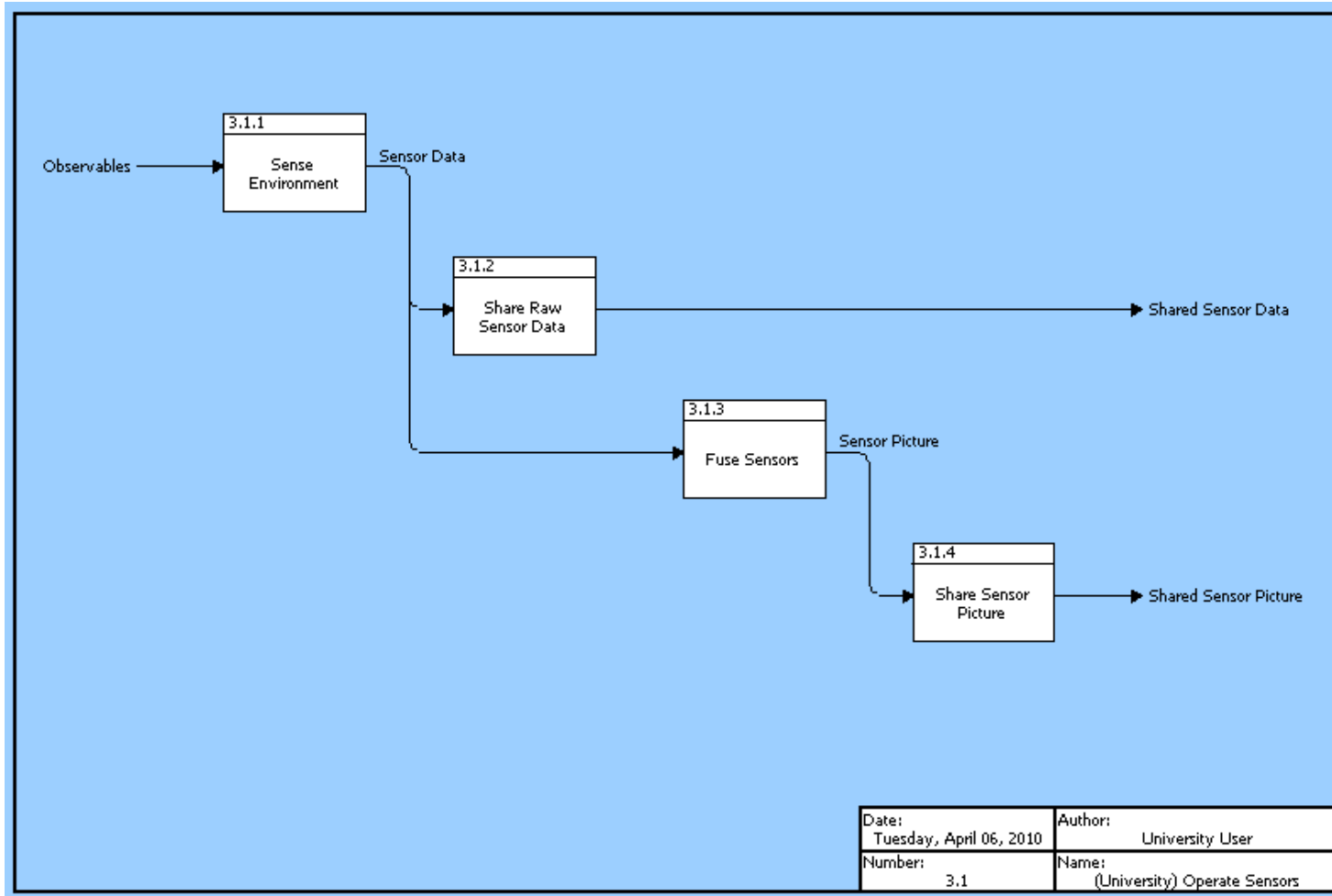

Figure 54. Operate Sensors Item Flow

[Figure 54](#) is a more detailed view of Operate Sensor's item flow. All of the items and functions have been previously defined. This figure shows that after Observables are transformed by Sense Environment, the Sensor Data enters the functions Share Raw Sensor Data and Fuse Sensors. Shared Raw Sensor Data's output is Shared Sensor Data which is sent to other operational vehicles to enhance their situational awareness. The output from Fuse Sensors is the Sensor Picture which is shared to the Collaborative Net in order to facilitate C2 efforts.

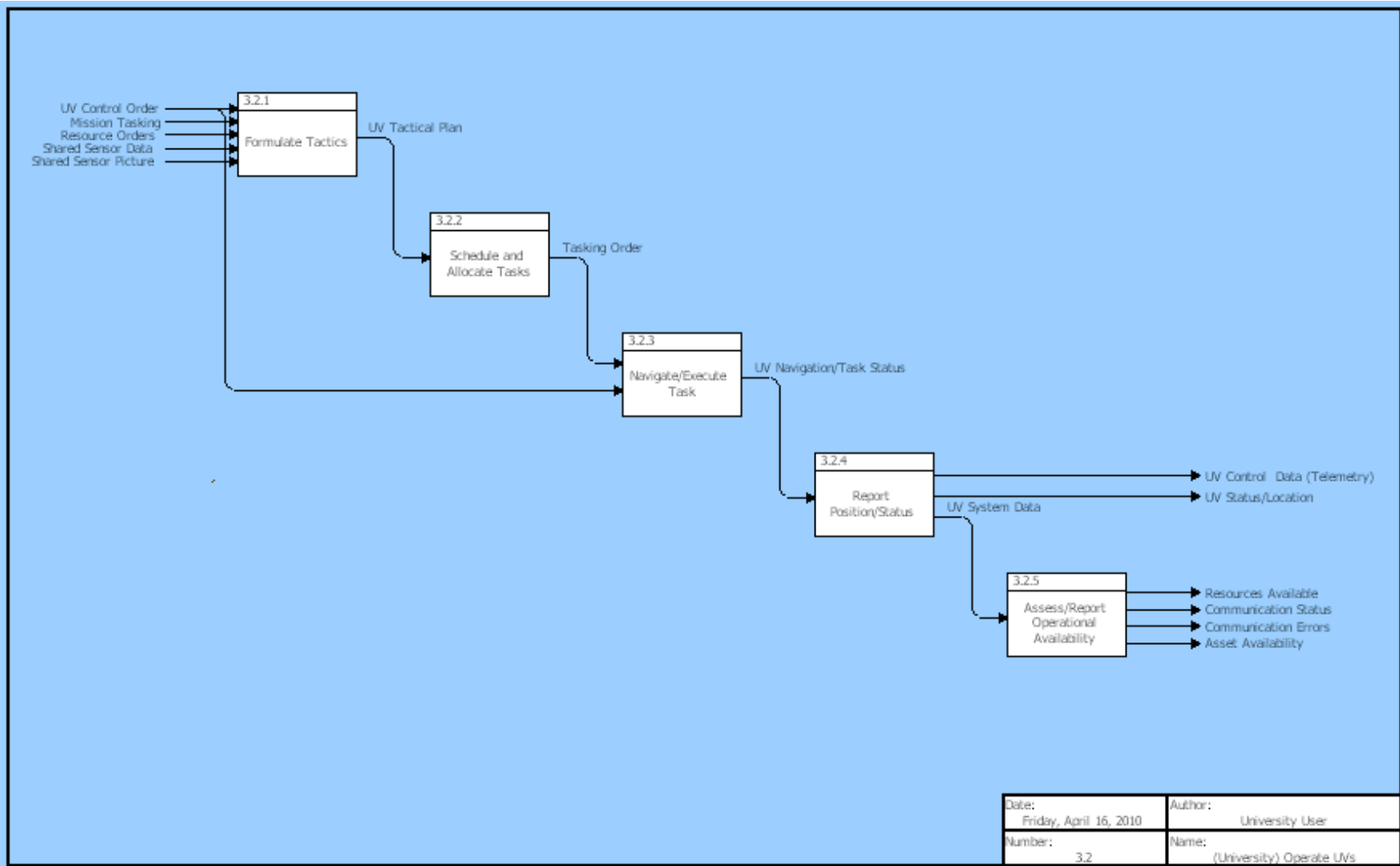

Figure 55. Operate UV Item Flow

[Figure 55](#). shows a more detailed breakdown of Operate UV's item flow. The input UV Control Order is input to both Formulate Tactics and Navigate/Execute Task. The UV Control Order provides the Formulate Tactics function an indication of where and what the UVs are doing. The UV Control Order is the C2 node's direction for the UV. The level of detail of the order will vary based on the level of autonomy of the UV. The output from Formulate Tactics is the UV Tactical Plan, which is a plan detailing how the UVs will accomplish a particular mission. For example, the plan could indicate which sectors different UVs will need to monitor while conducting a force protection mission. The UV Tactical Plan is the input for Schedule and Allocate Tasks. The output from Schedule and Allocate Tasks is the Tasking Order which gives specific direction to assets in order to execute a plan. For example, the order would assign a specific location for a UV to proceed to. The Tasking Order is the input for Navigate/Execute Task which results in the output UV Navigation/Task Status. The UV Navigation/ Task Status is an update on the navigational information such as location, course, and speed of the UV and the completion progress of the tasks it was assigned to complete. The UV Navigation/Task Status is input to Report Position/Status. The outputs of Report Position/Status are the UV System Data, UV Status/Location, and UV Control Data (Telemetry). UV Status/Location and UV Control Data (Telemetry) were discussed earlier when discussing inputs to the Collect sub function of Collaborate. UV System Data is input to Assess/Report Operational Availability and is the information which allows the assessment of the UVs operational status, including communication status, communication errors, resource levels, and asset availability. The outputs of Assess/Report Operational Availability were defined earlier as inputs to the Collect sub function of Collaborate. Assess/Report Operational Availability's outputs assist in the C2 nodes' understanding of what the operational assets level of readiness and resource requirements.

4.1.3.5. Functional Measures of Effectiveness

[Table 20](#) shows each function's MOE and unit of measure. The MOE is a measure of successful performance of a function. The performance of the function

should contribute to overall mission performance. The units of measure are specific ways that the MOEs are evaluated, such as percentages, seconds, and numerical values. [Section 5](#) will discuss the specific MOEs that were utilized to conduct modeling and analysis.

Function	MOEs	Units of Measure
1 Provide C2		
1.1 Observe	Link/communications (comms) availability	Percent comms availability (network uptime / total operation time)
	Availability of information sources	Percent info availability (lowest comms availability of all network nodes)
	Timeliness of information [detection to identification to availability of information on network (time target information is uploaded on network – time detected)]	Seconds
1.2 Orient	Capability of sense making tools (track fusion, data correlation, cognitive processing, considerations for HFE in interface design, etc.)	Percent target correlated (targets correlated / total target tracks)
	Capability of analysis tools (estimate of current situation, determining mission gaps, etc.)	Percent correct estimate (correct predicted situation / updated situation)
1.3 Decide	Competency of decision makers in setting/formulation of clear goals/objectives	Percentage of orders issued that are executed as intended (Correctly executed orders/total orders)
	Ability to propose COAs that improve situation which is difference between desired state and actual state	Numerical scale (i.e. 5 equals high improvement, 1 equals little improvement)

1.4 Act	Competency of decision makers in deciding C Link/comms availability	Percentage of COAs that meet mission objectives. (Successful COAs/Total COAs) comms availability (network uptime / total operation time)
	Operator competency OA (possibly computer assisted or deliberate)	Numerical scale (i.e. 5 equals high competency, 1 equals low competency)
	Clarity of mission, clarity of goals/objectives	Mission accomplishment rate (successful missions / total missions)
1.5 Share to Network	Link/comms availability	Percent comms availability (network uptime / total operation time)
2 Collaborate		
2.1 Operate in Network	Link/comms availability	Percent comms availability (network uptime / total operation time)
2.2 Manage Data	Availability of information	Percent info availability (lowest comms availability of all network nodes)
	Timeliness of information	Seconds
2.3 Collect Data	Ease of storage/retrieval of data (HMI design issue)	Numerical scale (i.e. 5 equals simple, 1 equals difficult)
2.4 Secure Network	Security policies set in place	Percentage of successful attacks (successful attacks/total attacks)
	Number of network attacks (time normalized)	Number of outages per time period (e.g. per month)
3 Conduct UV Operations		
3.1 Operate Sensors	Operator competency deviation from proposed COA)"	Numerical scale (i.e. 5 equals high competency, 1 equals low competency)

	Number of targets detected	False target rate (Wrong target identified / Total targets identified)
	Number of false/wrongly identified target reports	Mission accomplishment rate (successful missions / total missions)
	Mission accomplishment rate	Sensor availability (sensor uptime / total operational time)
	Sensor availability (failure rate)	Sensor failures per sensors operating
3.2 Operate UVs	Asset availability	UV availability (asset serviceable time / total time)
	Number of accidents/incidents	Total accidents/incidents
	Defect repair time	Seconds
	Defect rate	Defects per unit time, e.g. per 100,000 operational hours
	Ground crew competency (in identifying and fixing defects)	Numerical scale (i.e. 5 equals high competency, 1 equals low competency)

TABLE 20. FUNCTIONAL MEASURES OF EFFECTIVENESS.

4.2. COMMAND AND CONTROL ARCHITECTURE

4.2.1. C2 Architecture Considerations in Unmanned Platform

Unmanned platforms are “edge entities” within the Global Information Grid. On its own, it possesses knowledge of local situational awareness and contributes to mission objectives in a known and pre-established manner. According to Network Centric Warfare principles, this knowledge can be disseminated to a robustly networked force to realize the benefits of Metcalfe’s Law¹⁰⁸. There are a number of challenges to fully realizing such a concept. This section highlights key considerations in formulating a Command and Control (C2) architecture for supporting unmanned vehicles and its operations.

In most organizations, it is generally difficult to realize Gilder’s Law¹⁰⁹ without significant infrastructural investments. This is especially true for tactical communications in the field where it is infeasible to upgrade equipments on a frequent basis. As such, other alternatives need to be considered to better utilize the bandwidth. One potential alternative is the use of a cognitive radio that is able to alter its transmission and reception parameters in response to environmental factors for effective communication. Most unmanned platforms also have power constraints that limit sustainability and thus, the use of energy efficient waveforms via software defined radio is a potential research area.

Another candidate for improving bandwidth utilization is through the development of a Tactical IP communications protocol. This should be interoperable with traditional TCP/IP for communication to platforms on fixed infrastructure. Traditional TCP/IP protocol assumes a relatively stable networking environment with low latency. Hence, it tends to have high overheads (e.g. TCP 3-way handshake) and is generally not optimized for low bandwidth tactical communications. The new protocol should be developed to incorporate security mechanisms right from the start that limit identity spoofing, data modification and other attacks on confidentiality, integrity and availability. These concepts were previously discussed in [Section 3.5.2](#).

¹⁰⁸ Metcalfe’s Law states that the value of a network is proportional to the square of the number of nodes in the network.

¹⁰⁹ Gilder’s Law states that the total bandwidth of communication systems triples every 12 months.

Having a networked force is insufficient to realize the benefits of Metcalfe's Law unless they are able to communicate with one another effectively. A set of common data standards is needed to facilitate interoperability among the disparate C2 systems. There are two levels to interoperability:

At the syntactic level:

- All systems shall adopt standardized data & messaging formats. With a set of normalized schema, it eliminates the need to perform data conversion (and thus, no loss of accuracy or granularity) during inter-C2 exchanges.
- Data shall be tagged to indicate sensitivity and integrity markings. Hosts are to support the common use of digital signatures and cryptographic algorithms.
- All systems shall adopt an IP-based protocol. This reduces the need for dedicated gateway nodes for bridging communications and hence, resulting in faster OODA cycle.

At the semantic level:

- This refers to systems having the ability to interpret exchanged information in a meaningful and accurate manner. To accomplish this, it is essential to have an information exchange reference model where information exchange requests are unambiguously defined.
- Inadvertently, this information exchange is often tied to doctrinal and operational procedures and it may be relevant to assess whether they should be further refined.

After the C2 systems are able to communicate with one another, they need a mechanism to facilitate sense making. This may be accomplished by having a common operating picture that can be achieved by aggregating information from various networked sensors and presenting them in a cognitive manner. The use of Bayesian

network techniques can be deployed to infer likelihood of compromised host or performing data fusion when multiple sensors are reporting the same target. To reduce information overload, C2 systems may adopt a “publish and subscribe” technique on their area of interest instead of being presented with every piece of incoming information.

4.2.2. OV-1 High Level Operational Concept Graphic

The followings are the key capabilities of the UV fighting forces that the proposed C2 architecture addressed. [Figure 56](#). shows graphically the concept of the system.

- Self-protection - With the advent of more intelligent unmanned platforms being used in the theater and the advancement in artificial intelligence, these unmanned platforms could be used as a part of self-protection tactics. They could either be used as 'shields' for high value assets due to their relative cost in terms of monetary value or human lives or used as forward sensors to detect external threats such as high speed, low probability of detection missiles. The sensor range could be extend beyond typical radars, even into dangerous zones where there is a high probability of detection and risk of being taken down by enemy fire.
- Self-forming / self-healing networks - When squadrons of unmanned platforms are being sent into the combat zones where they are within the range of enemy sensor detection and fire, they bear the risk of being destroyed by low cost interceptors, such as improvised rockets that are being used in asymmetric warfare. In such scenarios, the concept of self-healing and self-forming networks is critical to ensure that the mission could still be carried out despite one of the leading platforms are being destroyed. Mechanisms to ensure proper succession to the being the master node is necessary. Adaptive routing of networks paths would be also required to ensure critical information/data can still be transmitted back to headquarters.

- Cross-medium rebroadcast - The operational environment comprises of several mediums, including space, air, land and sea, both surface and underwater. In order for optimal reach of data communications and network redundancy, there is a need to develop cross-medium rebroadcast capabilities. This would not only extend the range of communications but also the survivability of the networks. When a particular medium is jammed and denied, the network should remain functional by using another medium for communications using intelligence bandwidth allocation and rebroadcast capabilities.
- Sensor / platform diversity - To ensure maximal detection, a suite of different sensors being used with different angles of perspectives would be necessary. Hence, there is a need for different platforms and sensors to work collaboratively to ensure maximum sensor coverage and complete situational awareness. This would also mean that the unmanned platforms must be able to communicate and command with one another to collaboratively work towards the common mission.

The current C2 architectures would be unable to support these kinds of capabilities because most of them are too focused on specific missions to allow effective flow of commands and information among different nodes. A robust architecture such as the one proposed would need to be built to support the dynamic nature of the new UV fighting forces.

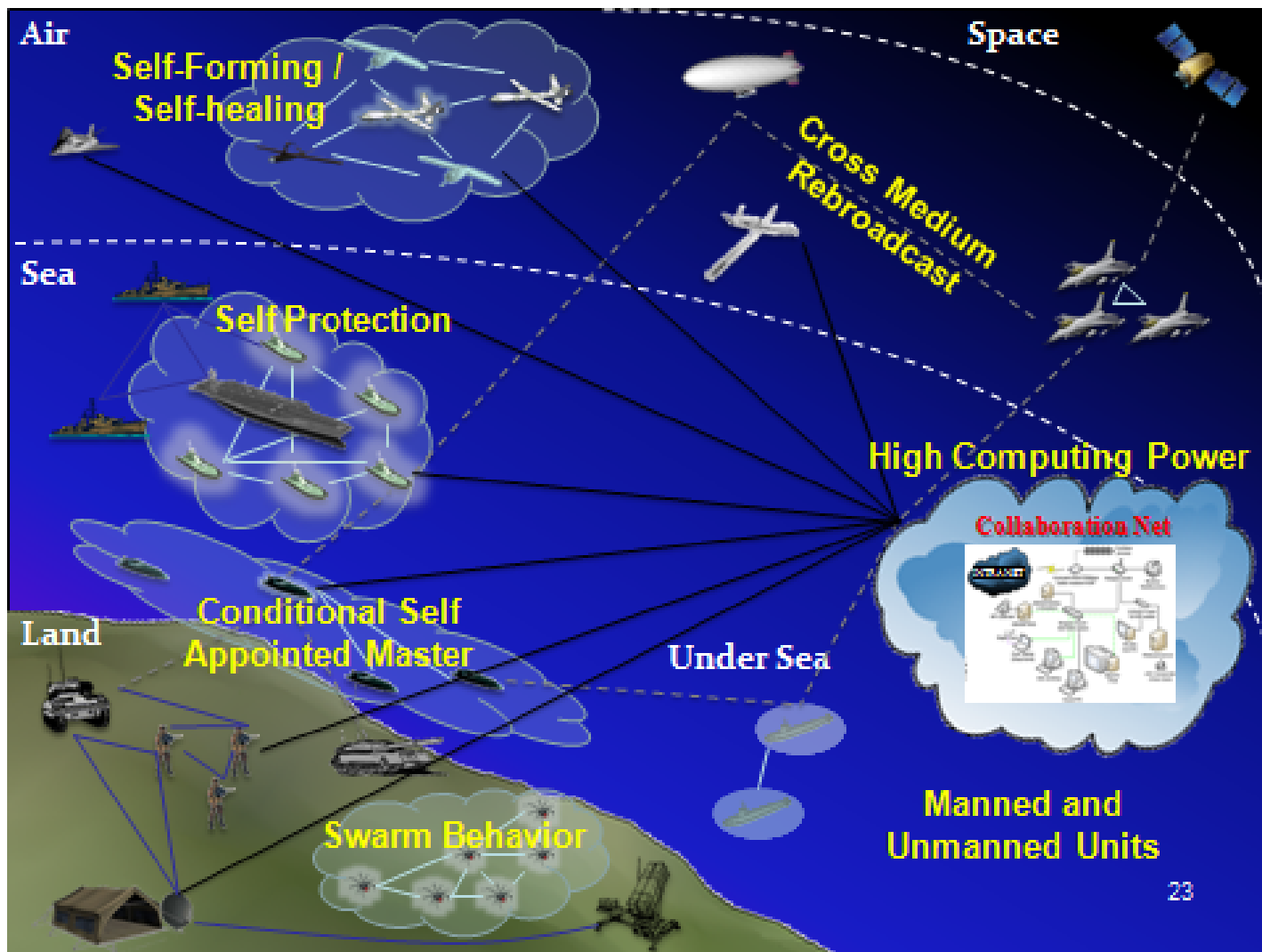

Figure 56. OV-1 High Level Operational Concept Graphic

4.2.3. OV-2 Operational Node Connectivity Description

The Operational Node Connectivity Description shows the connectivity and information flow between operational nodes.

4.2.3.1. Protective Operation

Objective of this operation: to form a protective physical shield around an asset to block kinetic attacks. The interactions are shown in [Figure 57](#).

A potential strategy for use of the UV drones would be maneuver the drone if possible, due to speed restriction, in the path of the incoming ASCM to absorb the destructive energy.

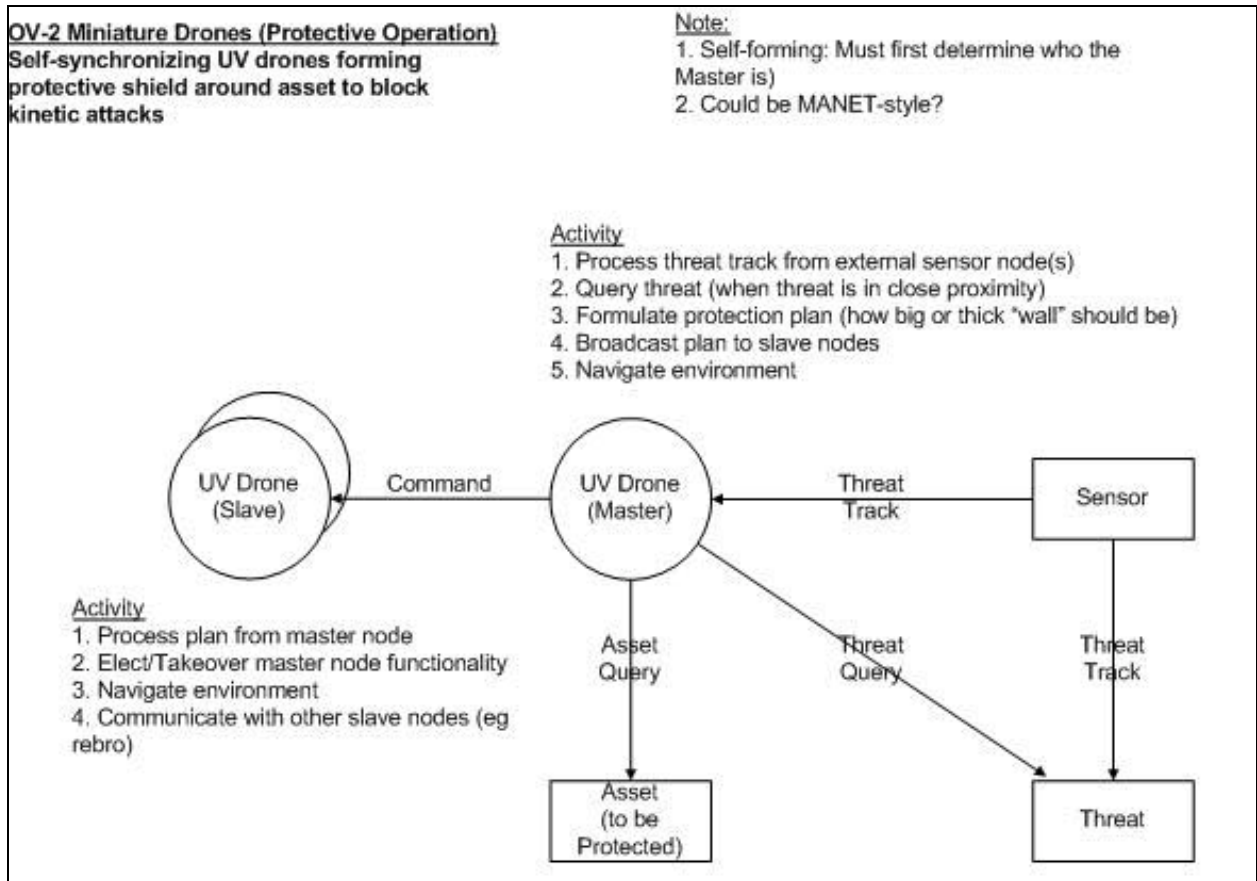

Figure 57. Protective Operation

4.2.3.1.1. Activities at the Master Drone:

The Master Drone is responsible for the processing of the threat track (location, altitude, velocity, and heading) from an external source, such as a sensor node. If the threat is within proximity of the swarm, the master drone takes responsibility to identify the threat and to query it, comparing it to its own repository of known threats, or with higher echelon of command. Once the threat track has been established, the Master Drone has to formulate a protection plan to be disseminated to the sub-ordinates under its command. The plan would include the number of sub-ordinate UVs to call upon, and the instructions to be given to each sub-ordinate to move into position (lat-long and altitude) with the precise timing to intercept the attack. The Master Drone will need to be able to broadcast the protection plan to the selected sub-ordinates, and ensure the sub-ordinate UVs are responding and moving according to the plan. The Master Drone will need to use its own sensors, together with situational awareness from sub-ordinate UVs or higher echelons to navigate the surrounding environment, taking into consideration both geographical features as well as strategic boundaries such as no-fly zones or political borders. It also has to determine the general heading and speed of the UV swarm it is responsible for.

4.2.3.1.2 Activities at the Sub-ordinate Drone:

The Sub-ordinate drone processes protection plans from the Master drone, and adjusts its heading and speed according to the instructions received. It must simultaneously be able to navigate the environment using its own sensors, in order to avoid collisions with other drones and geographic features. The Sub-ordinate Drone will have the ability to take-over and perform all Master drone activities, should there be a catastrophic loss of the Master drone. The Sub-ordinate drone also functions as a communications node to re-broadcast messages from the Master drone to drones that may have temporarily lost direct communications with the Master drone.

4.2.3.2. Search Operation

Objective of this operation: To collectively and synergistically search for and track targets in an area of operations, using a combination of sensors distributed over the UV swarm. Different types of sensors (for instance, radar, electro-optical / infra-red, hyper-spectral imaging) have varying effectiveness in finding targets in different terrain. With a mix of sensors looking at the same area of operations, there is higher chance of finding elusive targets. The interactions are shown in [Figure 58](#).

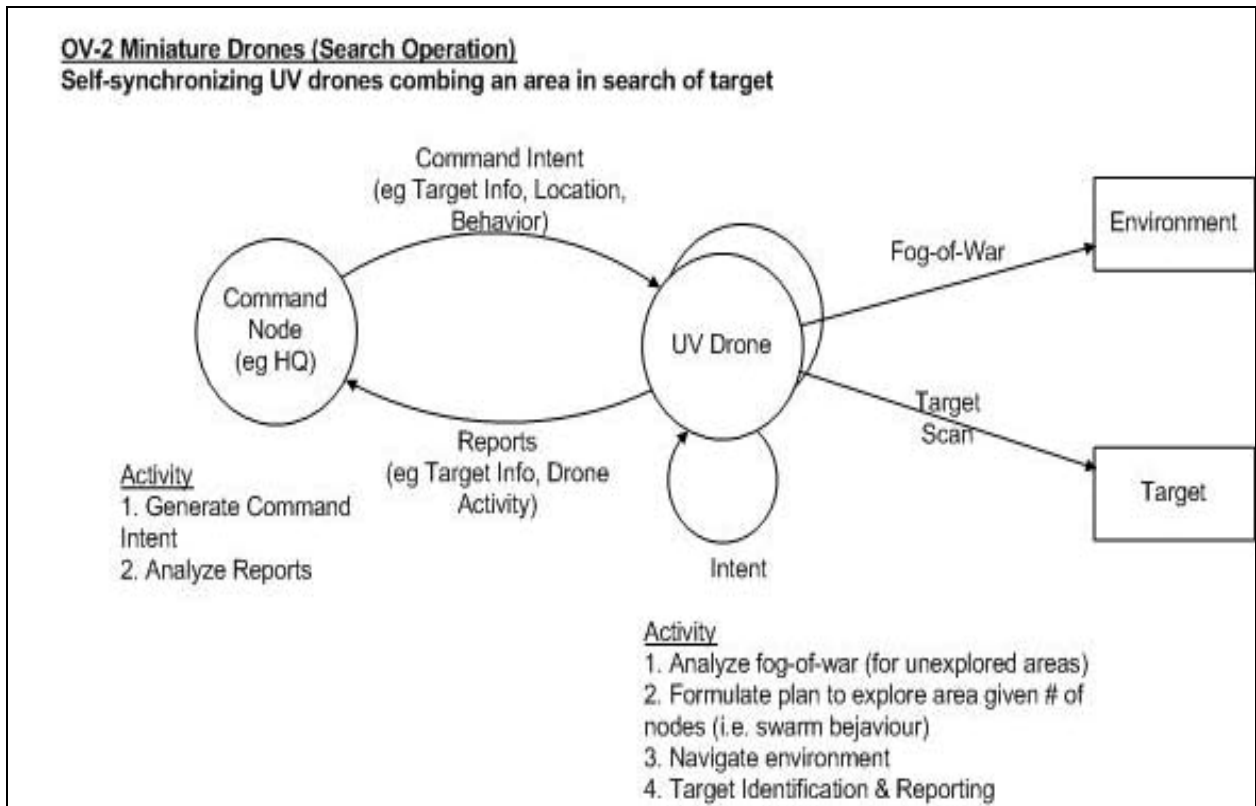

Figure 58. Search Operation

The UV drones receive command intent, including the area to search and a list of possible targets, from the command node (could be the headquarters), and will send target update reports back to the command node regarding the targets that have been detected.

The UV drones synchronize among themselves to determine search regions within their area of operations that have not been searched yet. Search regions are prioritized by

age of the last scan, the oldest region receiving the highest priority, since there could have been fresh target movements that have not been detected since the last scan of the region. A search plan is formulated (by the Master drone) and one (or more) Sub-ordinate UVs are tasked with searching a region. Targets may require several scans by different sensor types before being identified (for instance, a radar track indicating a target will need to be further examined by EO/IR sensors for classification and identification), so the UV drones will co-ordinate among themselves for the need to relocate the required sensors to further scan the tracks that have been found. Once targets are identified, the threat location (co-ordinates and heading) is reported to the command node.

4.2.4. OV-3 Operational Information Exchange Matrix

The Operational Information Exchange Matrix (OV-3) shows the information exchanged between nodes, the relevant attributes of that exchange such as media, quality, quantity, and the level of interoperability required.

4.2.4.1. Information Exchange Model

An Information Exchange Model was derived to aid in the creation of the OV-3 matrix. [Figure 59](#) illustrates this Information Exchange Model, and the typical flow of information between three types of nodes in an operational setting: a Headquarters (HQ), Manned System (MS) and Unmanned Vehicle (UV).

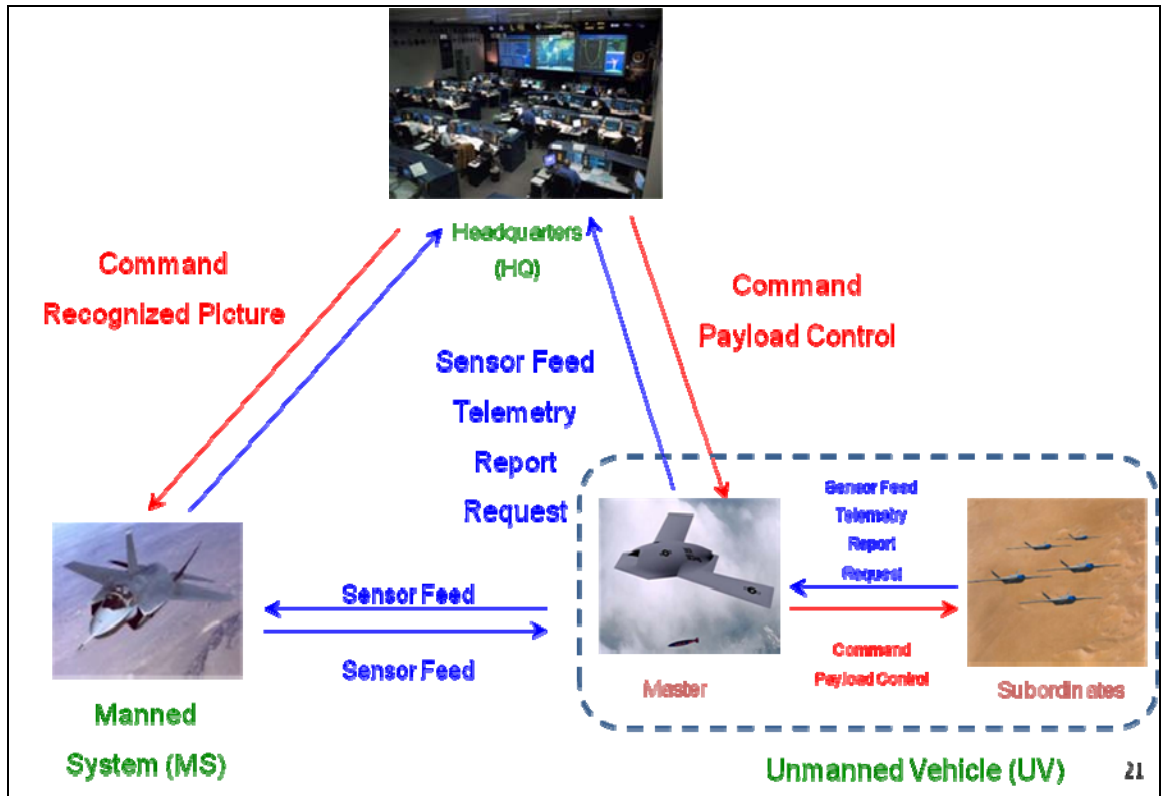

Figure 59. Information Exchange Model for Command and Control

4.2.4.2. *Categories of Information Exchange*

The various types of information exchanged in a typical operational setting can be grouped into the following categories:

- Information type – defines the origin and type of information source.
- Data type – defines the type of data to be transmitted.
- Bandwidth – defines the amount of resources that a Command and Control system needs to devote to transmit the information. ‘High’ refers to a range of more than 80kbps, ‘Medium’ refers to the range of 10 – 80kbps, and ‘Low’ refers to a range of less than 1-kbps.
- Timeliness – defines how timely urgent the information needs to be sent to a recipient node.
- Triggering events – defines the events that will trigger the sending of such information.
- CIA – defines the amount of Information Assurance required to protect the information, in terms of its Confidentiality, Integrity and Availability.
 - Confidentiality is defined as ensuring that information is accessible only to those authorized to have access.
 - Integrity refers to the condition that data cannot be created, changed, or deleted without proper authorization.
 - Availability is defined as having timely and reliable access to data and information services for authorized users.

4.2.4.3. MS/ UV (Master)-to-HQ Information Exchange

[Table 21](#) below shows the types of information that a MS or UV (Master) needs to send to HQ.

Category	Info Type	Data Type	BW	Timeliness	Triggering Events	CIA?
Sensor Feed	EO/Video Camera	Video (Live)	High	Milliseconds	- Algorithm - Operator - Time	IA Optional – C
	Radar	Data (Tracks)	Low	Seconds	- Algorithm - Operator - Time	CIA
	SAR/ISAR	Image	Mid	Minutes	- Algorithm - Operator - Time	IA Optional – C
	Gamma Radiation	Image	Mid	Minutes	- Algorithm - Operator - Time	IA
	Terra-Hertz	Image	Mid	Minutes	- Algorithm - Operator - Time	IA
	IFF	Data (Tracks)	Low	Seconds	- Algorithm - Operator - Time	IA
	Sonar	Data (Tracks) Audio	Low Mid	Seconds Milliseconds	- Algorithm - Operator - Time	IA
Telemetry	On-board Instrumentation	Data	Low	Variable	- Algorithm - Operator - Time	IA
Report	BIT Status	Data	Low	Minutes	- Algorithm - Operator - Time	A
	AI Decision Feedback	Data	Low	Minutes	- Algorithm - Operator - Time	IA
Request	Execution	Data	Low	Seconds	- Algorithm	CIA

TABLE 21. MS / UV (MASTER)-TO-HQ INFORMATION EXCHANGE.

In a typical swarm network concept of operations, the UV-Master will collate all relevant information from their UV-Subordinates and transmit only the necessary information back to HQ. The UV Master does not need to send all the information. Each element in the system sends only the relevant portions of data necessary to synchronize the common picture, resulting in a smaller bandwidth requirement.

The implications are that the C2 architecture is expected to be loaded the most especially if this involves the transmission of live video sensor feeds, which requires the highest bandwidth and lowest latency in the order of milliseconds.

Thus, for concepts of operations involving swarm operations and video feeds transmission, it is recommended that Operational Research (OR) tools be exploited to determine the optimal force numbers that the C2 architecture can handle, and yet not be overwhelmed by the bandwidth required.

4.2.4.4. *HQ-to-UV (Master) Information Exchange*

[Table 22](#) below shows the types of information that a HQ will send to a UV (Master).

Category	Info Type	Data Type	BW	Timeliness	Triggering Events	CIA?
Command	Mission Tasking Order	Data	Low	Variable	- Algorithm - Operator - Time	CIA
	Approval of Request	Data	Low	Seconds	- Operator	CIA
	Request for data	Data	Low	Minutes	- Operator	CIA
Payload Control	Sensor/Actuator Control	Data	Low	Seconds	- Operator	CIA

TABLE 22. HQ-TO-UV (MASTER) INFORMATION EXCHANGE.

HQ-to-UV (Master) information exchanges are typically command-and-control in nature. Hence, the key is to guarantee the confidentiality, integrity and availability of such information exchange, so as to ensure that commanders are able to command and control the assets and platforms in their areas of operations.

The C2 architecture must provide the framework for assuring that mission tasking orders and approval of requests have been sent to the correct UV, and that HQ staff are controlling the correct payloads and sensors. In providing this CIA assurance, it must be recognized that overheads will have to be incurred and this will increase the system's overall bandwidth requirements and must be taken into account.

4.2.4.5. *HQ-to-MS Information Exchange*

[Table 23](#) below shows the types of information that a HQ will send to a MS.

Category	Info Type	Data Type	BW	Timeliness	Triggering Events	CIA?
Command	Mission Tasking Order	Data	Low	Variable	- Algorithm - Operator - Time	CIA
	Approval of Request	Data	Low	Seconds	Operator	CIA
	Request for data	Data	Low	Minutes	- Operator	CIA
Recognized Picture	Tracks	Data (Fused Tracks)	Low	Seconds	- Algorithm	CIA

TABLE 23. HQ-TO-MS INFORMATION EXCHANGE.

Similarly, HQ-to-MS information exchanges are typically command-and-control in nature, and thus should focus on achieving confidentiality, integrity and availability.

4.2.4.6. *UV (Master)-to-UV (Subordinate) Information Exchange*

[Table 24](#) below shows the types of information that a UV (Master) will send to a UV (Subordinate).

Category	Info Type	Data Type	BW	Timeliness	Triggering Events	CIA?
Command	Mission Tasking Order	Data	Low	Variable	- Algorithm - Operator - Time	CIA
	Request Approval	Data	Low	Seconds	- Operator	CIA
	Request for data	Data	Low	Minutes	- Operator	CIA
Payload Control	Sensor/Actuator Control	Data	Low	Seconds	- Operator	CIA

TABLE 24. UV (MASTER)-TO-UV (SUBORDINATE) INFORMATION EXCHANGE.

In a swarm operation, UV-Master-to-UV-Subordinate information exchanges play a crucial role as the UV-Master is in command and control of all UV-Subordinates under their charge, and thus is responsible for issuing command orders and redirecting them for tasking during operations.

Without the man-in-the-loop element, there must be a secure mechanism for guaranteeing that issued mission orders are genuine and valid. Again, this can be done by focusing on the confidentiality, integrity and availability of such information exchanges.

4.2.4.7. *UV (Subordinate)-to-UV (Master) Information Exchange*

[Table 25](#) below shows the types of information that a UV (Subordinate) will send to a UV (Master).

Category	Info Type	Data Type	BW	Timeliness	Triggering Events	CIA?
Sensor Feed	EO/Video Camera	Video (Live)	High	Milliseconds	- Operator request	IA Optional – C
	Radar	Data (Tracks)	Low	Seconds	- Operator request	CIA
	SAR/ISAR	Image	Mid	Minutes	- Operator request	IA Optional – C
	Gamma Radiation	Image	Mid	Minutes	- Operator request	IA
	Terra-Hertz	Image	Mid	Minutes	- Operator request	IA
	IFF	Data (Tracks)	Low	Seconds	- Operator request	IA
	Sonar	Data (Tracks) Audio	Low Mid	Seconds Milliseconds	- Operator request	IA
Telemetry	On-board Instrumentation	Data	Low	Variable	- Algorithm	IA
Request	Execution	Data	Low	Seconds	- Algorithm	CIA
Report	BIT Status	Data	Low	Minutes	- Algorithm	A
	AI Decision Feedback	Data	Low	Minutes	- Algorithm	IA

TABLE 25. UV (SUBORDINATE)-TO-UV (MASTER) INFORMATION EXCHANGE.

In a swarm network, the bandwidth of such information exchanges will depend on the ratio of UV-Subordinates to UV-Masters in the network, as well as the nature of the mission.

Concepts of operations that will load the C2 architecture the most are swarm operations with a high UV-Subordinate to UV-Master ratio and Intelligence Surveillance and Reconnaissance missions involving the transmission of live video sensor feeds, which requires the highest bandwidth and lowest latency in the order of milliseconds.

4.2.4.8. *Concluding Remarks*

The OV-3 Informational Exchange Matrix will allow planners of the C2 architecture to gain insights into which aspects of the architecture are subjected to the most loading, as well as the types of operational scenarios that will cause the loading. Through that, the optimal force composition and numbers can be determined via the use of appropriate OR simulation tools to stress-test the architecture.

4.2.5. *OV-5 Operational Activity Model*

The Operational Activity Model (OV-5) shows the activities, relationships among activities, inputs and outputs of the different system nodes.

The OV-5 models for force protection and reconnaissance operations are being constructed.

4.2.5.1. *OV-5 Force Protection*

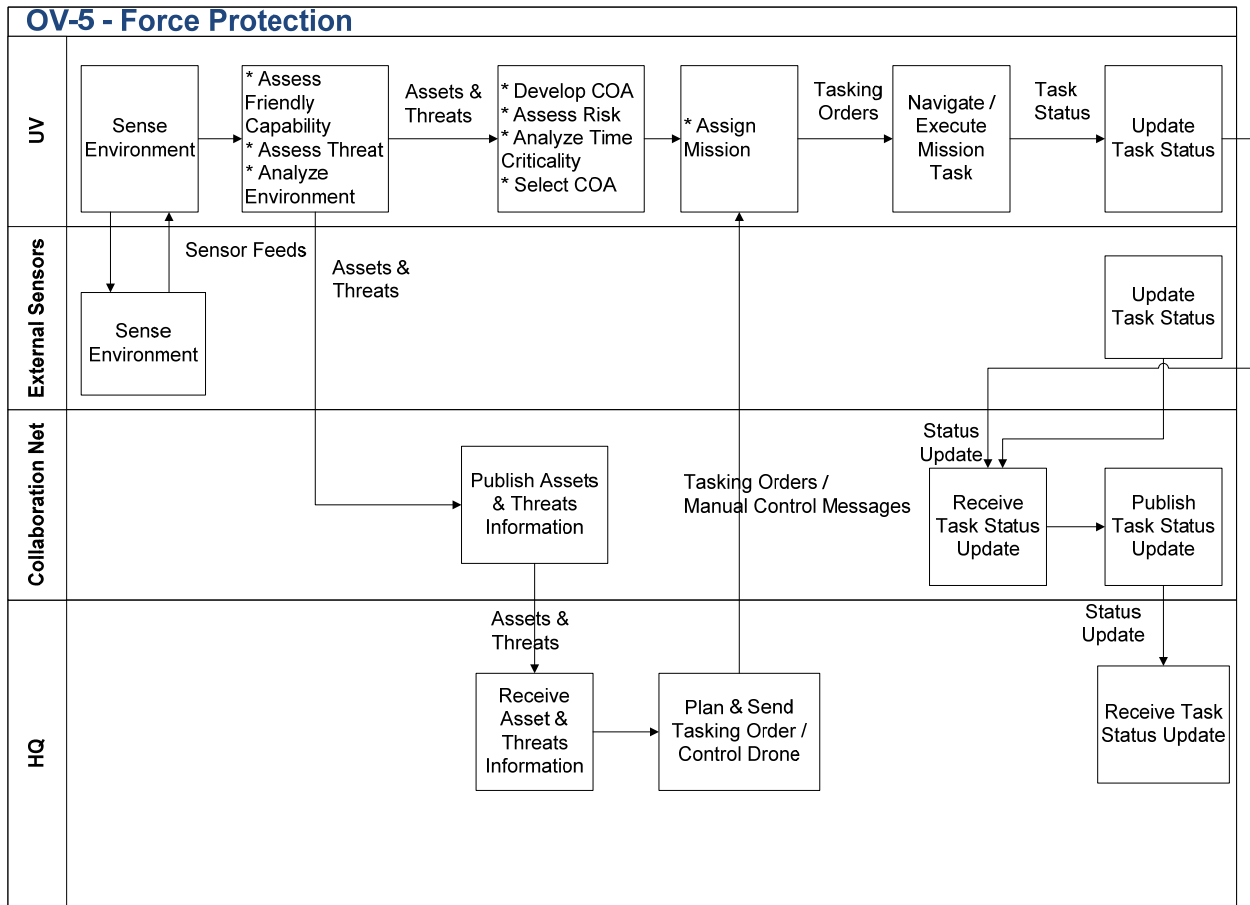

Figure 60. Operational Activity Model (OV-5) for Force Protection

Figure 60. shows the Operational Activity Model (OV-5) for Force Protection scenario. UV will exchange data with External Sensors and send Assets and Threats information to the Collaboration Net. The Collaboration Net sends Threats information to HQ where HQ will use it in mission planning. Activities for UV include sense environment, assess friendly capability, assess threats and risks, analyze environment, develop COA, carry out assigned mission, navigation and update mission status. For the External sensors, their main activities are sense environment and update mission tasks status. Collaboration Net basically publish Assets and Threats information which is send to HQ for mission planning. HQ will make use of Assets and Threats information for planning. Commands are then send to UV by HQ. HQ will also receive tasks status

updates from Collaboration Net which receive the status information from both external sensors and UV.

4.2.5.2. OV-5 Reconnaissance

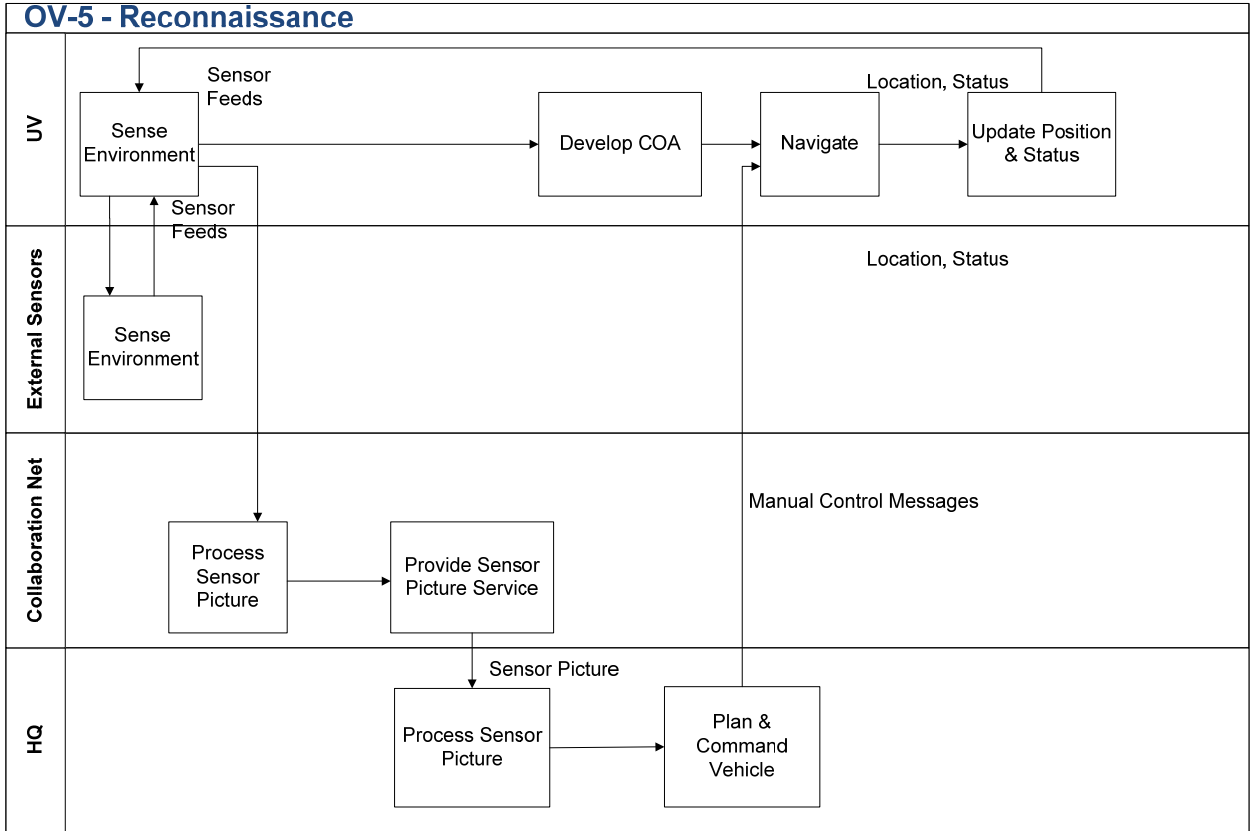

Figure 61. Operational Activity Model (OV-5) for Reconnaissance

The Operational Activity Model (OV-5) for the Reconnaissance scenario is shown in [Figure 61](#). In the diagram, the UV exchanges information with External Sensors and send data to Collaboration Net. The Collaboration Net processes the input data from UV and send a sensor picture to HQ so that HQ can make use of the processed sensor picture in planning. The HQ will then interact with the UV by sending commands to UV. Activities carried out by UV are Sense environments, develop COA, navigate and update position and status. External sensors sense the environment for potential threats. Collaboration net will process data to useful information for HQ. HQ will further analyze the useful information and use it for planning purposes.

4.2.5. SV-1

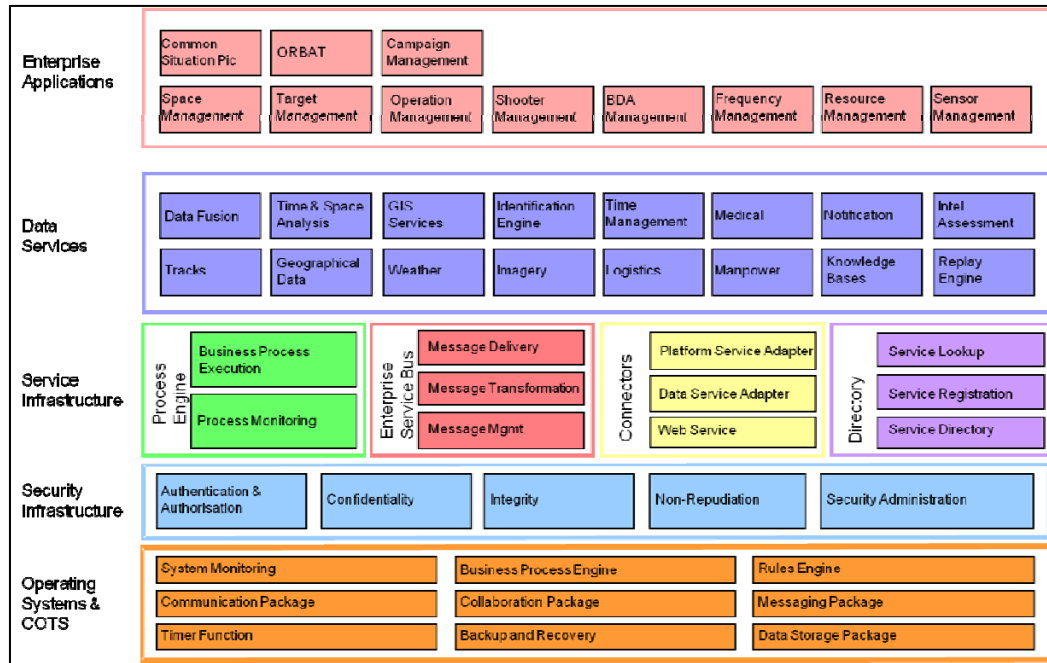

Figure 62. High Level Conceptual System View

A layered approach for building the system is proposed. [Figure 62.](#) illustrates the structure. The system will consist of:

- Operating Systems & COTS This layer contains the operating system and the required communication's stack. Items included on this level would be customized operating systems or firmware, depending on the application, or device drivers for low level communication.
- Security Infrastructure A layer of security infrastructure is built to provide the necessary information assurance. This layer isolates the Operating Systems.
- Service Infrastructure This layer provides services such as process engines, messaging, connections to legacy systems and directory lookup for applications to invoke. By isolating the raw communication stack from the applications, it improves portability, modularity and maintainability.

- Data Services This layer provides a standard interface for the various disparate data forms/format. Additionally, this data layer serves the enterprise applications to form a service-oriented framework.
- Enterprise Applications The final layer allows custom built applications to support different environments and missions. Unlike the previous layers, the enterprise application layer can be installed on the platform itself.

4.2.6. Communications and Network

The Communications and Network (CN) systems provide the transport mechanism to deliver information between blue-force entities in a timely and organized manner. In the C2 process, the CN systems link geo-dispersed sensor information to form a live common operational picture. The live common operational picture allows commanders to react in a timely fashion and make well-informed decisions in response to changing events. CN systems support efficient and effective dissemination of orders to the nodes which execute the counter measures. The aim is to shorten the "sensor-to-shooter" time in the OODA cycle.

In general, the ideal CN systems will fulfill operational demands in the following aspects:

Connectivity: To connect entities that requires exchanging information during the operation. For wireless communications, direct connectivity is determined by the range of CN systems deployed in the mission. If the information source is not within range of information sink, then multiple hop connectivity may be required to bridge the gap.

Range: The communication range is expected to be as large as possible to allow dynamic of force projection with minimum need of deploying intermediate re-broadcast stations.

Channel capacity: To provide adequate channel capacity to deliver information at the rate required by the C2 applications. Types of data traffic may vary

from lightweight track information packets to heavyweight streaming traffic like video teleconferencing (VTC) sessions.

Latency & Jitter: Time-critical application traffic, e.g. targeting information to guide missile to fast moving target, requires near real-time end-to-end latency in order to be effective. Time-sensitive application, e.g. video / audio streaming are sensitive to jitter.

Information Assurance: here is a need to denying adversaries from exploiting the information that was transmitted in the common exposed medium and turn it against our blue forces.

Link Reliability: Communications on-the-move in a multi-path environment suffers multipath fading that disrupts communications connectivity

Resource optimization: To meet the growing demand of channel capacity, there is a need to optimize the spectrum utilization efficiency. Dynamic assigned multiple access (DAMA) schemes should be employed whenever possible to ensure that every subscriber station access the transmission medium only when it has data to transmit.

Low Probability of Interception/ Detection (LPI/LPD): To increase the survivability probability of our blue-forces operating in the tactical environment, there is a need to deny adversaries from exploiting our wireless transmission with their electronic warfare (EW) capability.

High Service Availability: To provision systems redundancy and avoid designing single-point of failure in CN architecture. Service recovery process has to be rapid and responsive to minimize service downtime.

4.2.6.1. *Communications & Network Topology*

The CN topology and concepts support Unmanned systems (UMS) which operate in the air, land and sea domains.

UMS (Air/ Surface) Operation

Satellite communications (SATCOM) offer global area coverage that enables beyond-line-of-sight (BLOS) communications between forces. By the year 2030, UMS technology will have achieved high levels of autonomy for executing missions. UMS operators will no longer need to assert direct control of the UMS platforms.

For large-scale clustered UMS operating at BLOS range (>1000km), it is difficult to connect every UMS to their command center, in terms of SATCOM RF spectrum. The Master-Subordinate operation concept was introduced to reduce the reach-back traffic demand by the UMS cluster. This transforms a STAR-topology to a TREE topology for the tactical wireless network. This is shown in [Figure 63](#).

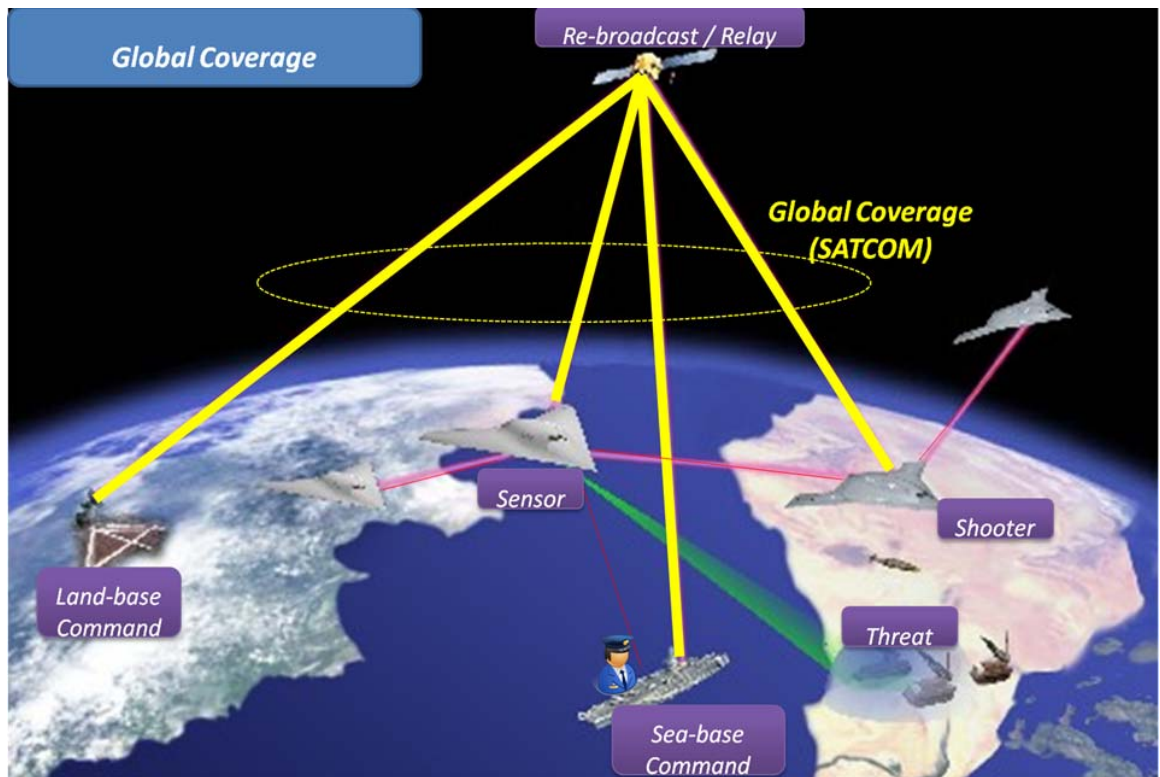

Figure 63. Global Coverage

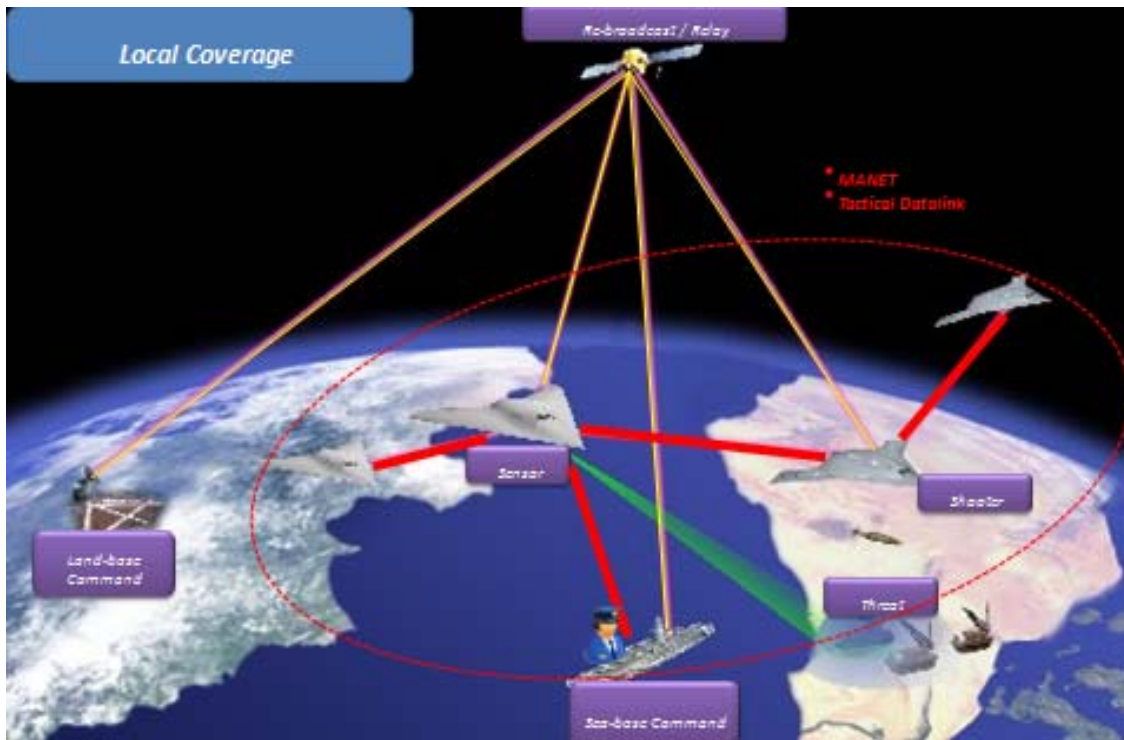

Figure 64. Local Coverage

For example, in UMS air operations, UAVs operating in the same vicinity can form a local tactical network cluster. In each cluster, one of the UMS shall be nominated as the Conditionally Self-Appointed Master, relaying traffic to the HQ on behalf of its subordinates via long range link. On-board processing in the Master can be employed to filter out repeated tracks from the reach-back traffic, hence optimizing traffic exchange through the reach-back link. This is shown in [Figure 64](#).

The local tactical network can be formed by a tactical datalink network or a Mobile Adhoc Network (MANET). MANET features self-forming and self-healing routing capability, and is highly reliable and easily deployed without the need to set up a central access point or infrastructure. They are sometimes referred to as "wireless mesh networks", which employ similar concepts of having every node in the network being capable of routing information through the network. The network changes dynamically and frequently due to the mobile nature of each radio node. Traditional routing algorithms developed for the internet with fixed infrastructure will not work in

environments where nodes can join and leave the network at any time. The routing may pass through several heterogeneous links with different capabilities. Therefore, self-forming and self-healing networks are evolving areas of research for finding efficient routing protocols and optimizing the channel utilization with minimal packet collision and idle time.¹¹⁰

During operation, if the Master is destroyed or isolated from the cluster, the tactical network shall re-nominate a new Master within the cluster. This approach eliminates single point of failure to assure high availability.

UMS (Land) Operation:

For large-scale, land-based UMS platforms, the direct ground-to-ground communications links are generally subjected to lateral foliage penetration attenuation and terrain blockage. This reduces the range of direct communications link between land based UMS and other nodes. While SATCOM offers a quick solution for coverage, connecting large number of UMS platforms via global SATCOM coverage may deplete SATCOM resources.

¹¹⁰ Motorola Technology Position Paper, *Mesh Networks*, Motorola Inc.
http://www.motorola.com/staticfiles/Business/Products/Wireless%20Broadband%20Networks/Mesh%20Networks/Documents/static%20file/wp_technology_position_paper.pdf (accessed June 4, 2010)
Wikipedia, *Wireless mesh network*, http://en.wikipedia.org/wiki/Wireless_mesh_network(accessed June 4, 2010);
Wikipedia, *Mobile ad hoc network*, <http://en.wikipedia.org/wiki/MANET>(accessed June 4, 2010)

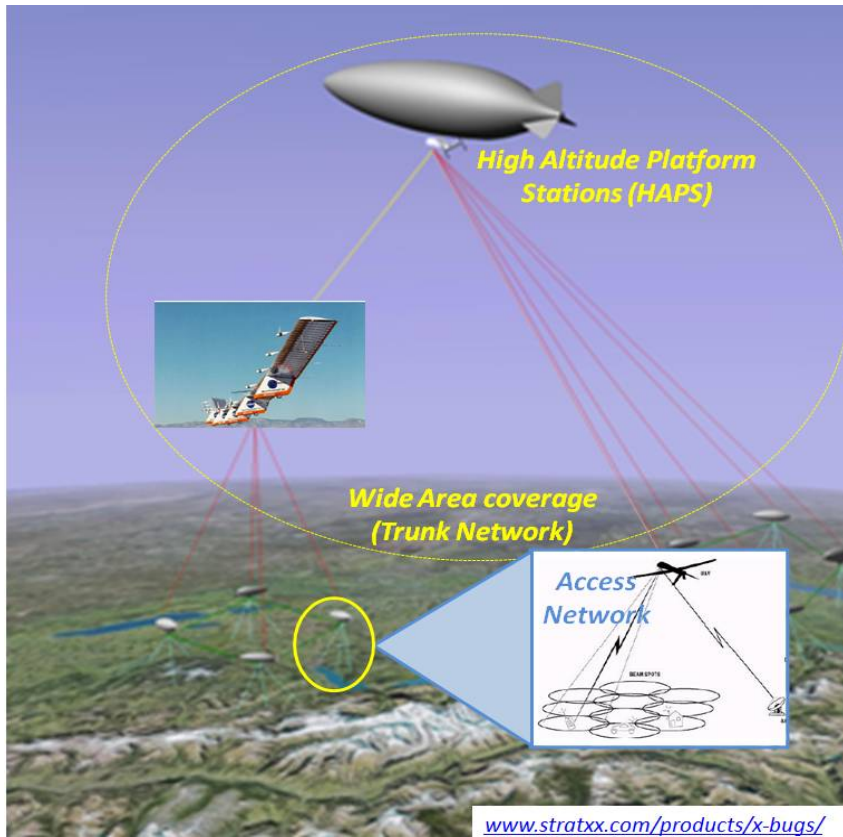

Figure 65. High Altitude Platform Stations (HAPS)

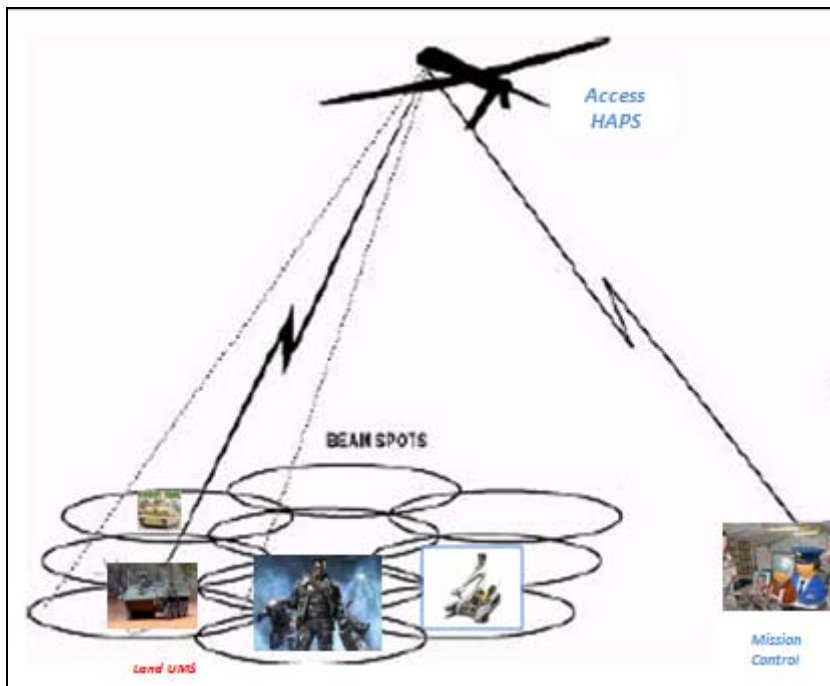

Figure 66. Access HAPS
201

An alternative to SATCOM is the use of an aerial communications node (ACN). These utilize a relay concept using high-altitude, high-endurance surrogate satellite platforms, such as High-Altitude Platform Stations (HAPS), as shown in [Figure 65](#). HAPS is an intermediate alternative that provides additional link capacity while overcoming foliage and terrain challenges faced by the UMS operation. The UMS can be linked to Access HAPS, as shown in [Figure 66](#), which cover their region. Potential technologies today for access network are Tactical Datalink and WiMax. The high elevation-angle reduces foliage penetration and lowers the probability of terrain blockage. The link of cellular base-station to the Access HAPS or HAPS form a multi-tier core network backbone to extend the coverage of the wide area communications over land theater.

UMS (Underwater) Operation

In addition to acoustic waves there are other means for wireless transmission of signals under water. Very low frequency radio waves (30Hz - 300Hz) will propagate through conductive sea water, but require large antennas and high transmitter power. Optical waves do not suffer so much from attenuation, but they are affected by scattering. While laser technology is still being perfected for practical use, acoustic waves remain the optimum solution for communicating under water in applications where tethering is unacceptable.

The achievable data throughput and the reliability of underwater acoustic communication systems are measured by the bit error probability. This probability varies from system to system, but is always subject to bandwidth limitations of the ocean channel. In the existing systems, there are usually four kinds of signals that are transmitted: control, telemetry, speech and video signals.

During the past few years, significant advancements have been made in the development of underwater acoustic communication systems in terms of their operational range and the data throughput. Acoustically controlled robots have been used to replace divers in performing maintenance of submerged platforms. High quality video

transmission from the bottom of deep ocean trenches (6500m) to surface ships and data telemetry over-the-horizon has been demonstrated.

The emerging communication scenario in which the modern underwater acoustic systems will operate is that of an underwater data network consisting of both stationary and mobile nodes. These nodes can be located on UUVs, bouys, or permanent nodes mounted on the sea bed. This network is envisioned to provide exchange of data such as control, telemetry and video signals between multiple network nodes. Remote users will have access to the network via radio link connecting to a central node based on a surface station.¹¹¹

Despite its long range performance, propagation velocity of acoustic waves in water (~1500m/s) is 200,000 times slower than RF propagation (3×10^8 m/s). This effect will have an impact regarding the speed of transmission. If the signal is transmitted across long range acoustic communications, the application will suffer significant end-to-end latency. For example, a 3km acoustic link has a latency of two seconds. Hence the range of the "last-mile" acoustic link is limited by the most latency requirement that the UMS requires to operate effectively for its mission. This depends on the type of applications that the acoustic communications link needs to support. Interactive control using live video feedback, sensor feed, and telemetry data are examples of these applications. Also, medium access schemes supporting the multiple user access within the local area network needs to have sufficient guard interval or back-off time to avoid transmission collision between different mobile stations.

SATCOM or surrogate satellites can be used to bridge the long range gap between the C2 center and large number of remote UMS while maintaining long stand-off distance.

¹¹¹ Milica Stojanovic, Underwater Acoustic Communication, Department of Electrical and Computer Engineering, Northeastern University. Wiley Encyclopedia of Electrical and Electronics Engineering. <http://web.mit.edu/people/millitsa/resources/pdfs/ency.pdf> (assessed on June 4, 2010)

The cluster concept can be applied to UUVs, with a Master undertaking the role of RF-to-Acoustic communications relay and utilizing acoustic communications to facilitate the cluster local area network. If the tactical mission allows, a surface ship could be used as both the C2 center and the Master for the cluster network. This is shown in [Figure 67](#).

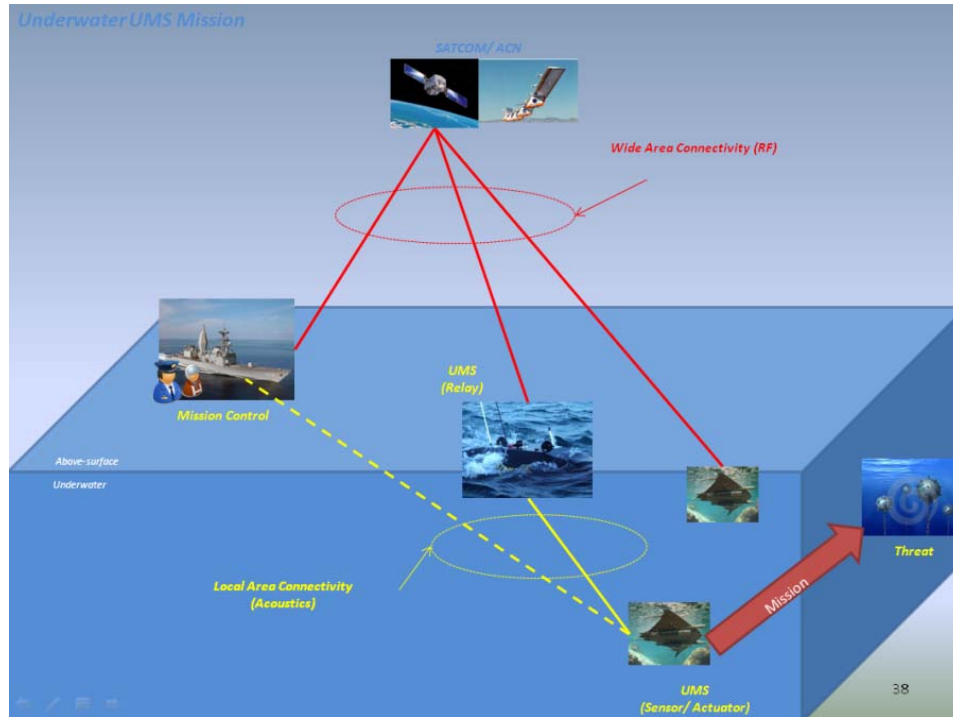

Figure 67. Underwater Application of System

THIS PAGE INTENTIONALLY LEFT BLANK

5.0. EFFECTIVENESS ANALYSIS / FLEET-SIZING

5.1. OBJECTIVE AND APPROACH

5.1.1. ASCM Threat Scenario

In 2030, the US military will continue to rely heavily on its Navy to conduct a wide spectrum of operations such as: keeping sea lanes open to maintain the flow of trade and commerce around the world during peacetime, deployment of humanitarian assistance in the form of personnel and logistics while conducting a disaster relief operation, and projecting its air and ground forces into the theater of operations during a time of war. While the US Navy has maintained its dominance of the high seas for several decades now, new and rising threats such as the development of advanced ASCM must be addressed in order for the Navy to safeguard its high-value assets such as its Carrier Battle Groups (CVBG) while conducting these operations in the high seas.

Currently, ASCMs such as the Brahmos¹¹² can travel up to speeds of Mach 3 and perform intelligent sea-skimming maneuvers to reduce its detection probability after being launched. In the near future, more advanced ASCMs are expected to travel up to Mach 4 or even Mach 5, further reducing the reaction time the CVBG has to detect and destroy the threat. While one missile may not be sufficient to sink a large ship such as a cruiser or a carrier, any hit would likely reduce its operational effectiveness and prevent it from fully achieving its mission. Present ASCM tactics also call for the weapons to be fired in salvos in an attempt to overwhelm the defensive screen. The logic behind any protection system, therefore, would be to provide detection of the hostile ASCM as early as possible, so that the CVBG's own countermeasures such as its anti-missile missiles or other close-in protection measures can be activated to neutralize the threat in time.

Amidst the CVBGs of today, early warning screens that detect incoming hostile aircraft are established by tactical warning aircraft such as the E-2C Hawkeye operating several hundred miles away from the carrier. However, there is a limitation of early

¹¹² The Brahmos was co-developed in India and Russia in 2006, and has an operational speed of 3675 km/h, range of 290 km and carries a 300kg payload.

warning for ASCMs to about 30 miles. The C2 architecture proposed in this report will enable the use of unmanned systems to provide a more persistent screen deployed at distances further away from the CVBG to extend the range and improve the detection probability of ASCMs. This persistent surveillance mission can be achieved with the projected future capabilities of a Group 4, as described in [Section 3.3.2.](#), unmanned system with advanced algorithms that allow collaboration on search operations yet have collision avoidance, as well as the miniaturization of aerial surveillance radars for smaller platforms than a large manned aircraft like the E-2C.

5.1.2. Determine UAV Fleet Size for ASCM Early Warning Screen

The determination of UAV fleet size was performed to address the specific operational scenario whereby a squadron of unmanned aerial systems is deployed to enhance the protection of a CVBG with a continuous early ASCM warning screen. The purpose of deploying the unmanned systems is such that as a system, the CVBG's effective screening radius and reaction time is improved by a certain threshold / objective value versus the CVBG's current capability against the threat of incoming ASCMs. The specific outcome of this analysis is a notional fleet size and force effectiveness of a fleet of unmanned systems required to enable the warning screen.

5.2. OPERATIONAL SCENARIO: DEFENSE OF CARRIER BATTLE GROUP

The scenario modeled in this study consists of a large-scale conflict with a near peer adversary in the year 2030. A CVBG is en route to a potential engagement area. It has been established that the adversary's ASCM capability imposes such a significant threat that continuous 100% area coverage of the threat axis is necessary. The manned early warning aircraft does not have the endurance or coverage area capacity to perform such a task. Present day technology registers ASCM speeds of Mach 3 which equates to about 1 km/sec. The models used here assume that technology will only continue to develop and that ASCM speeds could reach Mach 4+ (1.4 km/sec) by the year 2030. This only reduces the CVBG's response time to intercept such threats before the High Value Unit is impacted by such an adversary's weapon. UAVs are used in this model to

provide expanded radar coverage, which increases the response time for engagement of ASCMs.

Detection ranges for ASCMs must be greater than what currently provided the CVBG organic sensors. The enhanced detection range will lengthen the response time in order for the battle group's anti-ASCM capabilities to be more effective in protecting the High Value Unit. Current capabilities used in this study assume 50 seconds from first detection of an incoming ASCM until impact of the High Value Unit. ASCM defense procedures use a shoot-shoot-look strategy that takes approximately 15 seconds per cycle. Time of last launch to successfully interdict the incoming weapon is 10 seconds out, which puts the ASCM 12-15 km away from the High Value Unit when the last defensive weapon is away. The UAV early warning screen effectively gives the battle group two full engagement cycles, with sufficient time to perform a second shoot-shoot-look engagement after the first, giving the CVBG the opportunity to launch up to four weapons to intercept the incoming provide for its own defense. This study will show how a persistent screen of unmanned systems with ASCM detection capability will enable an increased battle group response time with the capability to counter-shoot more defensive weapons.

Figure 68. illustrates a notational CVBG as well as the desired ASCM radar coverage of each sector.

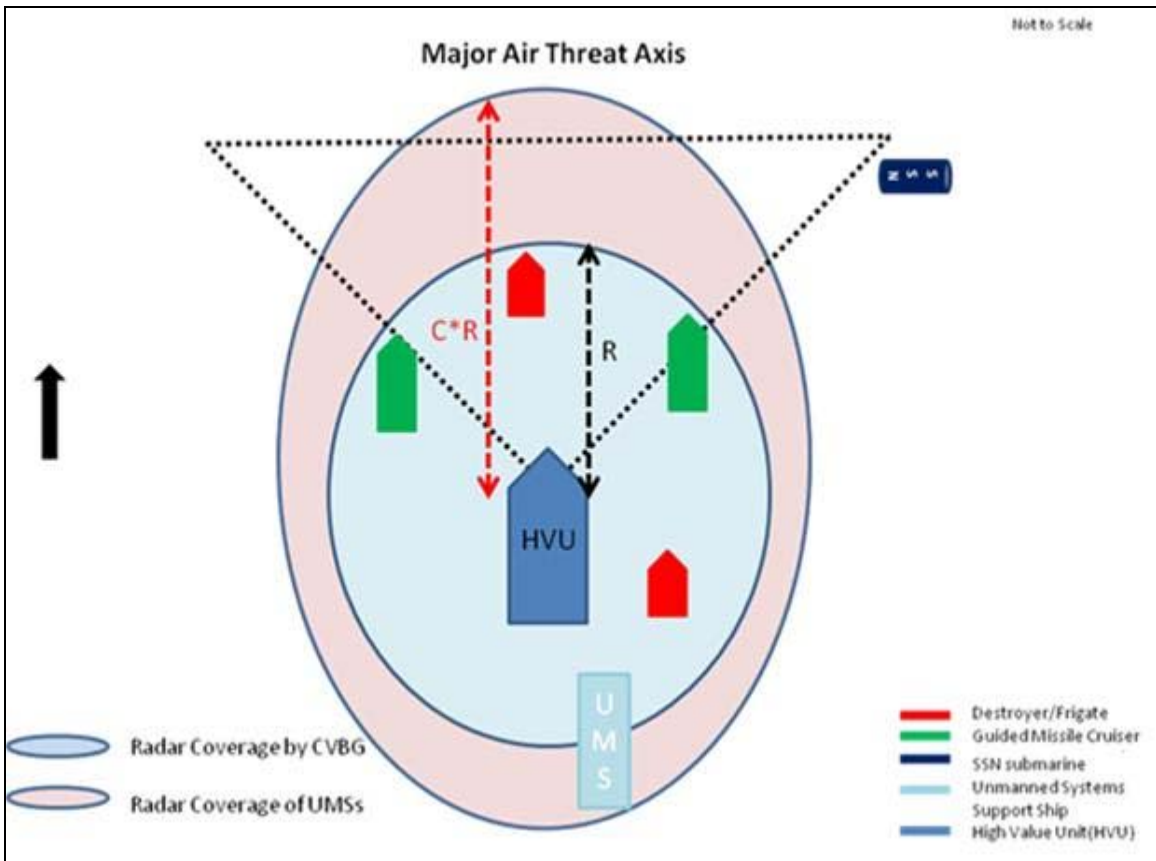

Figure 68. Typical CVBG Formation with associated Threat Axes and ASCM Radar Coverage Area

5.3. DEPLOYMENT CONCEPT

The deployment concept of utilizing unmanned systems as part of CVBG protection, while detailed, is articulated here so as to give the reader a better understanding of the “states” that the system are envisaged to be in. These states are subsequently used to compose the Discrete Time Markov Chain during the formulation of the problem.

As mentioned in the previous section as part of the Operations Concept, the CVBG will begin deploying the UAV protective screen of unmanned systems after leaving safe harbor. Whether transiting across the high seas or within its theater of

operations, the threat protection level as well as the axis of threat focus (thereby determining the level of coverage desired), is a decision left to commander of the CVBG. Whether the unmanned systems are launched from a single ship (specially commissioned to launch, recover and maintain the unmanned systems), or are launched from multiple ships (each ship within the CVBG today is modified to house part of the system), is also not prescribed here as part of the problem formulation – the solution can take either form.

As such, a single unmanned aerial platform can be in one of the following states:

State of Ingress - The unmanned platform is launched from its host ship or airbase, and flies enroute toward its designated patrol orbit. This includes the time it takes for final operational checks and safety checks to be performed on the platform, the time it takes to taxi towards the designated runway, time waiting on deck, takeoff time, and finally flight time towards the holding pattern. Out of all these, the flight time towards the holding pattern is envisaged to be the longest. During ingress, there is a probability that the platform will malfunction and be required return to the host ship without ever reaching the pattern.

Time on Station – Whether as part of the orbiting patrol screen and actively searching for ASCM or as a “hot standby”, the platform has now reached the designated patrol orbit and forms part of the overall defensive screen. This is the useful mission time of the platform. Since there are an optimal number of unmanned platforms in the air around the CVBG, the new platform that has just completed its ingress to the pattern is actually replacing another platform that has run low on fuel or has malfunctioned and is now leaving the pattern. The new platform is effectively performing a one-for-one replacement of the exiting platform to cover the gap it has left behind. While on station, the platform is employing its radar to actively search for ASCMs and other airborne threats in its designated area of search. Any anomalies detected in its area of search are reported back to the CVBG (the information possibly routed through other platforms). For each time interval on station, there is a probability that the platform will malfunction, requiring it to leave the holding pattern for an emergency return to the host ship.

State of Egress – The state in which the unmanned is exiting its designated patrol orbit because it has run low on fuel, or has encountered a malfunction. Either way, it is now flying back toward its host ship or airbase, and the state of egress includes flying time, landing time, recovery time, time to taxi and being stowed-away back in the hanger of the host ship. Again, the flight time is expected to be the longest amongst all of these.

Turnaround Time –Upon completion of a mission, the platform, if not in need of repair, will be refueled and prepared for its next mission in the hanger deck of the host ship. This includes time for preventive maintenance tasks, downloading of its mission data, software and diagnostic checks, and readied for taking on another mission.

Repair Time – The unmanned platform goes into a state of repair in the hanger deck of the host ship if it has encountered a malfunction while performing its mission. Repair time implies corrective maintenance but not preventive maintenance tasks. The time it takes for a platform to be repaired is modeled as a binomial process, meaning that with each time step, the platform will either (1) be repaired with certain probability; (2) or continue to remain in a state of repair at the next time step. This is to account for the fact that repair times are variable depending on the severity of the malfunction encountered.

5.4. MOES & MOPS

The measure of effectiveness (MOE) of the defensive screen is the ability to improve the detection and engagement times against ASCMs. Supporting measures of performance (MOP) are:

1. Probability of successfully maintaining the required number of UAVs in orbiting stations, given mission failures.
2. Fleet Size. The total number of UAVs required in a fleet to provide the defensive screen.

5.5. RADAR CONSIDERATIONS

5.5.1. Today's Technological Limitations

Currently there are no known sensors onboard UAVs that can detect sea skimming missiles. The current employment of sensors onboard the UAV includes intelligence, surveillance, target acquisition and reconnaissance (ISTAR). Detection of at least 30km is not uncommon. The challenge is to be able to detect a sea skimming missile travelling at hypersonic speed at that distance. The difficulties involved in the detection of a sea skimming missile are associated with the signal to clutter ratio and the multipath returns.

Target to Clutter Ratio (TCR). [Figure 69.](#) shows the fluctuation of the TCR with range at sea states 0, 2 and 3. All else being equal, it can be seen that as the sea state increases the TCR decreases. Radar echoes from sea decreases with reduction in frequency.

If the target of interest is small, higher microwave frequencies are preferred (X-band). Higher frequencies also offer better range and angle resolution. Over the sea, horizontal polarization at low and moderate sea states results in less sea clutter than vertical.

Unlike receiver noise, clutter echoes are generally correlated from pulse to pulse, and sometimes even from scan to scan. The techniques of rapid antenna scan for detection of small targets in the sea, and time compression for detection of moving targets in sea clutter are examples of detection techniques that can be worked on to take advantage of the nature of correlated clutter echoes.

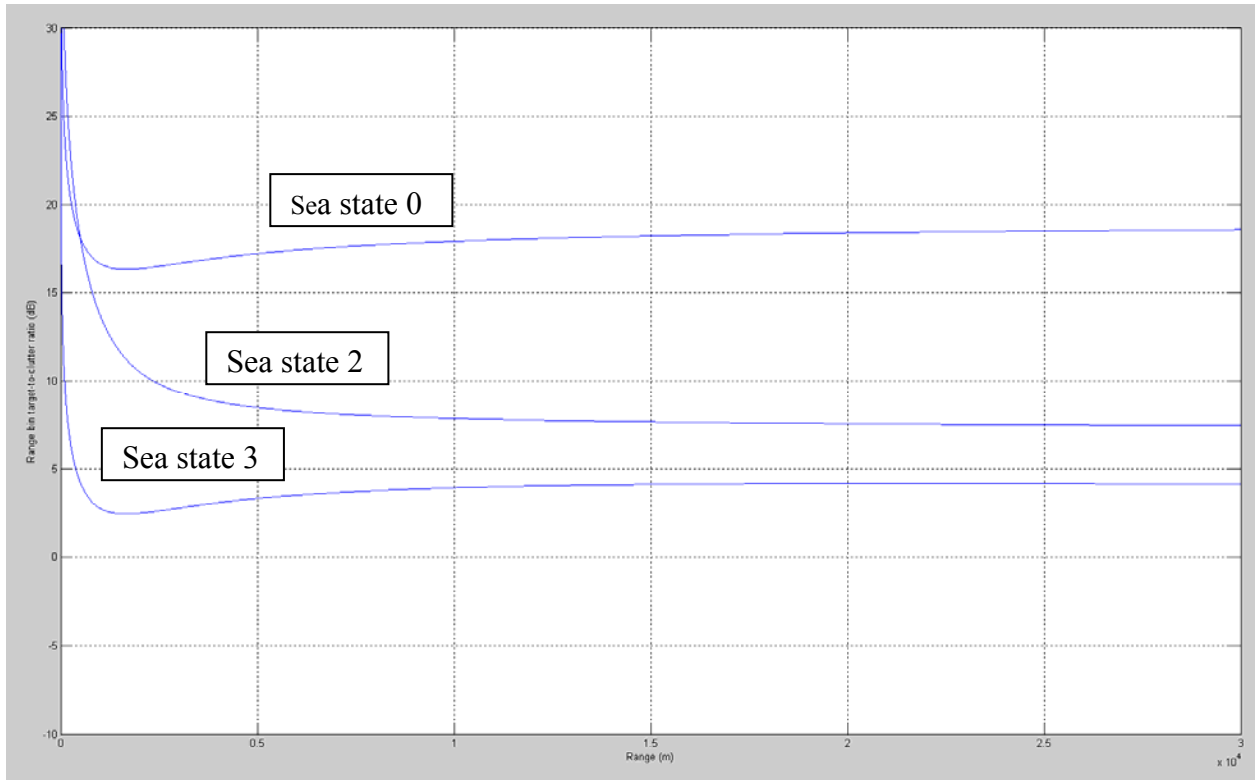

Figure 69. TCR plot (Range Resolution 3.3m, UAV=5000ft, Missile=30m, X band, (SS 0,2,3))

Multipath. Multiple-input multiple-output (MIMO) techniques have been well studied in communications offering advantages where multipath environments can cause fading. Radar waveform rejection of multipath requires that the range resolution cell be smaller than the range difference (range resolution) between the direct and multipath echoes. The majority of MIMO radar configurations have focused on multistatic arrays that have sufficient spatial separation to decorrelate the target's RCS scintillation. These networks combine the received data non-coherently to average out the scintillation. Another form of MIMO radar uses multiple orthogonally coded waveforms from individual transmitter elements of a phased array which are then combined coherently upon receive to form multiple beams. This concept holds huge potential and can be exploited by a swarm of UAVs in the detection of sea skimming missile.

Multi Function Radar. With the miniaturization, lowering cost of processing and the pressing need for extreme beam agility the goal is to have a radar which will perform multiple functions in one system. As such it is envisaged that the

sensor which will be mounted on the UAVs will be a phased array multi function radar capable of providing surveillance and tracking a fast moving target.

Key Specifications. For an operating height of 5000ft trying to detect a sea skimming missile (supersonic speed) travelling at a height of 30m above sea level the range resolution needed is 3.3m. Using a frequency of 9.3GHz with an aperture diameter of 2m, the 3dB beamwidth is given by 1.2° .

$$\text{Range Resolution} \quad \Delta R = \frac{2h_a h_t}{R} = \frac{2(1666)(30)}{30000} = 3.3\text{m}$$

$$\text{3-dB Beamwidth} \quad \theta_{3dB} = 1.25 \frac{\lambda}{d_a} = 1.2^\circ$$

$$\text{SNR} = \text{TCR} = \frac{P_{RT}}{P_{RC}} = \left(\frac{\sigma_\tau}{\sigma_{0i}} \right) \frac{1}{\Delta R(\theta_{3dB})R_\tau}$$

Where σ_τ is the RCS of the target

and σ_{0i} is the backscatter coefficient for sea state i (i=0-4)

[Figure 70](#). shows a plot of the sea backscatter coefficients as a function of grazing angle. It can be seen that the sea backscatter coefficient increases as the sea state increases.

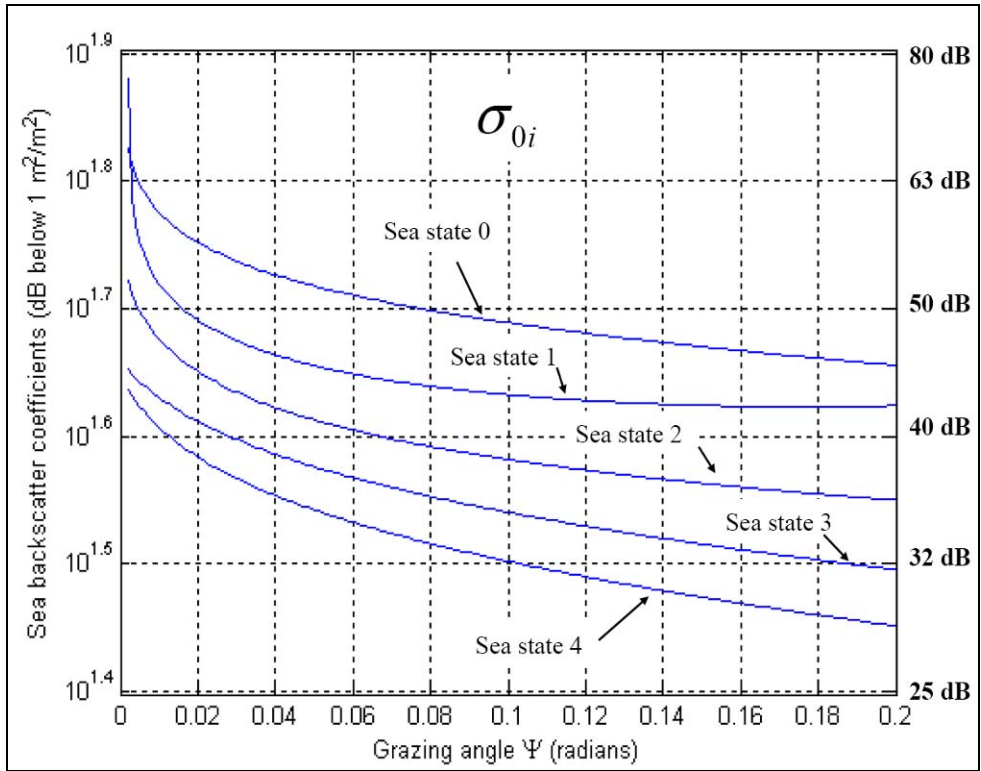

Figure 70. Plot of Sea backscatter coefficients vs Grazing angle

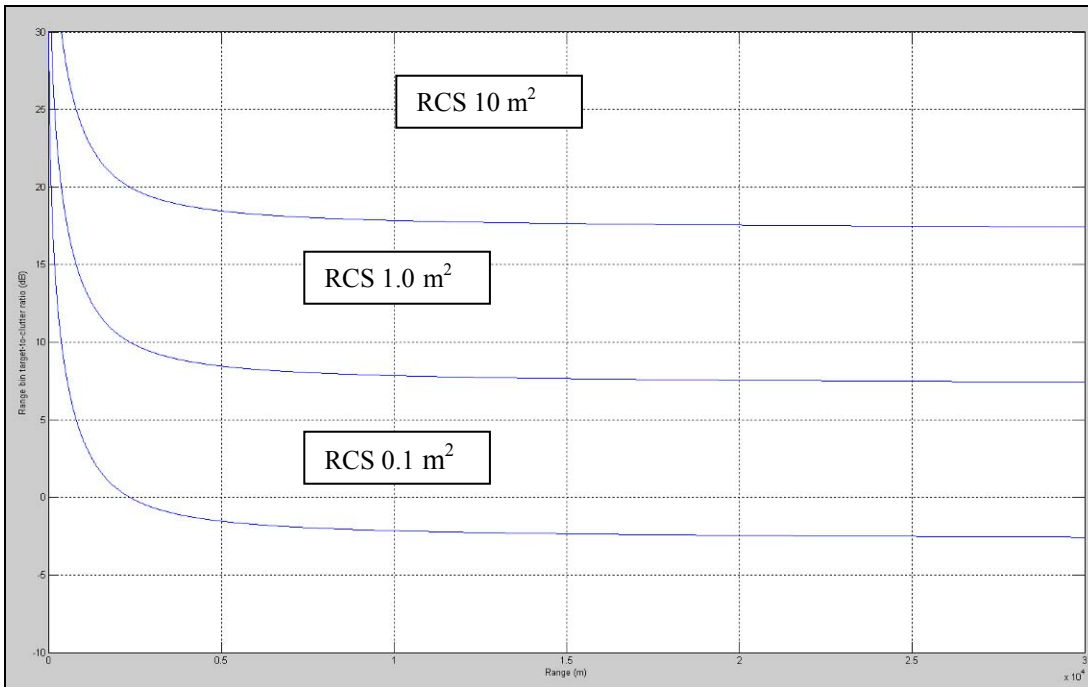

Figure 71. TCR vs Range (Range Resolution 3.3m, UAV=5000ft, Missile=30m, X band, (sea state 2))

Based on current receiver design and signal processing techniques, the TCR needed for detection is at least 20dB. To achieve a detection range of 30km at sea state 3, the TCR will need to improve to below 10dB [Figure 69](#). This is good for a target RCS of 1-10m². Variation of TCR vs range is plotted for RCS 0.1, 1 and 10m² in [Figure 71](#). It can be seen that the TCR increases as the RCS increases.

5.6. KEY ASSUMPTIONS

From the technical considerations enumerated in [Section 5.5](#), some key assumptions need to be made for the analysis:

1. ASCM RCS of 0.1 to 1 m².
2. Assume Sea States are between 0 to 3. The radar is only effective for this range, and the UAVs are able to land and take-off from the deck of the carrier.

3. Detection to Firing Time. The time between detection to firing, a factor determined by human Observe-Orient-Decide-Act (OODA) cycle, is taken to be a constant 10 sec in this analysis.

4. Track Handling. A capability to continuously track the incoming ASCM with sufficient accuracy to guide the interceptor missile(s) from the CVBG to the incoming ASCM is assumed.

5.7. ANALYSIS METHODOLOGY AND RESULTS

5.7.1. A Two Phase Model

In order to determine the UAV fleet size, modeling was conducted in two phases. Modeling Phase I derived the number of UAV's required to ensure sufficient radar coverage of the circumferential perimeter of the early warning screen. Each position that is required to be filled by a UAV is termed an aerial picket station, denoted by k . Modeling Phase II is a discrete event simulation takes Modeling Phase I further by considering the finite endurance and failure rates of the UAV platform and sensors, and outputs the UAV fleet size required to support the mission.

5.7.2. Modeling Phase I: Derive Required Number of Aerial Picket Stations

5.7.2.1. Overview

Modeling Phase I is a geometric model formulated to cover the given perimeter based on a ring of UAVs, assuming each UAV's detection range as a cookie cutter with a given effective radius. The model can also be applied for a non-circular protection pattern, for example when the region in front of the CVBG is given a larger alert time than that behind the CVBG, the stems if the expected major threat axis is from the front. However, in this example, the threat is expected to be omni-directional, necessitating a circle for the early warning screen.

5.7.2.2. Description

For a given CVBG, with an existing detection radius R , the model calculates k UAVs, equidistant from each other, in a circle with radius R_{uav} . As shown in

Figure 72., each UAV in the early warning screen is modeled to have a side-scanning radar with a scanning angle of θ , and a detection radius R_d .

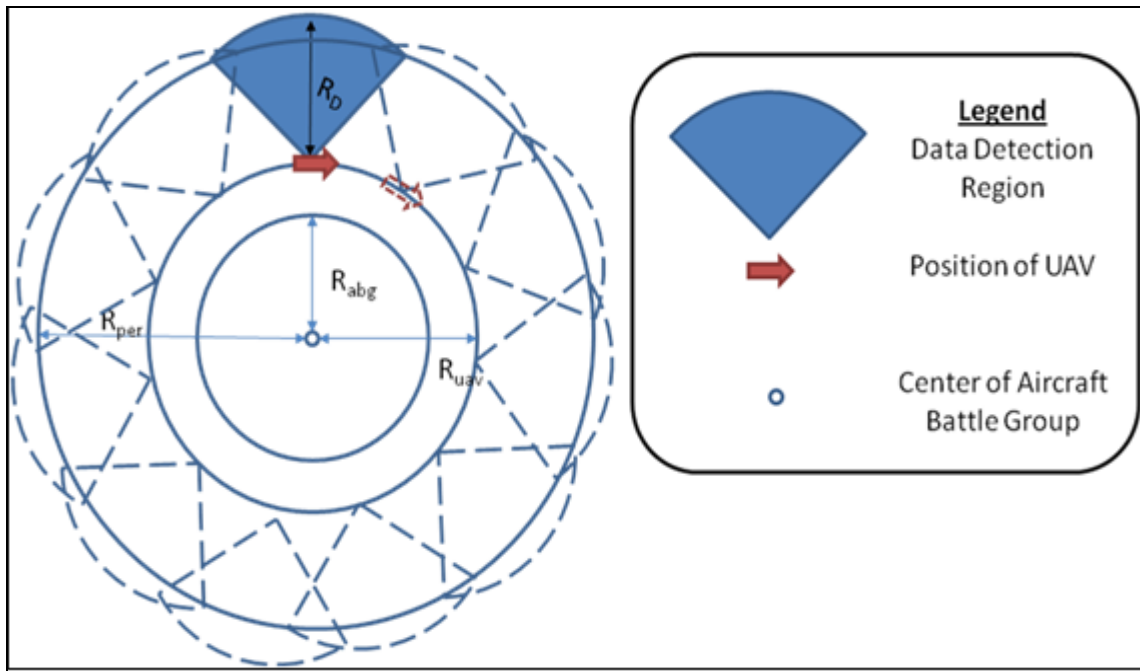

Figure 72. Early Warning Screen of UAVs

Engagement Sequence. The engagement takes place as follows:

1. Enemy missile enters UAV early warning screen perimeter with speed V_m .
2. Enemy missile stays in UAV detection region for at least $T_{min,1}$ in order for the UAV to detect the missile (T_1). Neighboring radar coverages must overlap for $T_{min,1}$.
3. Command center at CVBG completes the OODA loop for the engagement in an additional $T_{min,2}$ from T_1 . The interceptor missile flies out from the aircraft battle group and travels at speed V_{amm} (assume instantaneous acceleration) towards the incoming enemy ASCM.
4. Interceptor missile engages enemy missile at R . The Command Center at the CVBG performs a battle damage assessment (BDA) and, if there are

surviving ASCMs, proceeds to engage with a second salvo of interceptor missiles, if necessary.

Geometric Analysis. Based on the geometry of the early warning screen, k can be determined through the equations that follow based on [Figure 73](#).

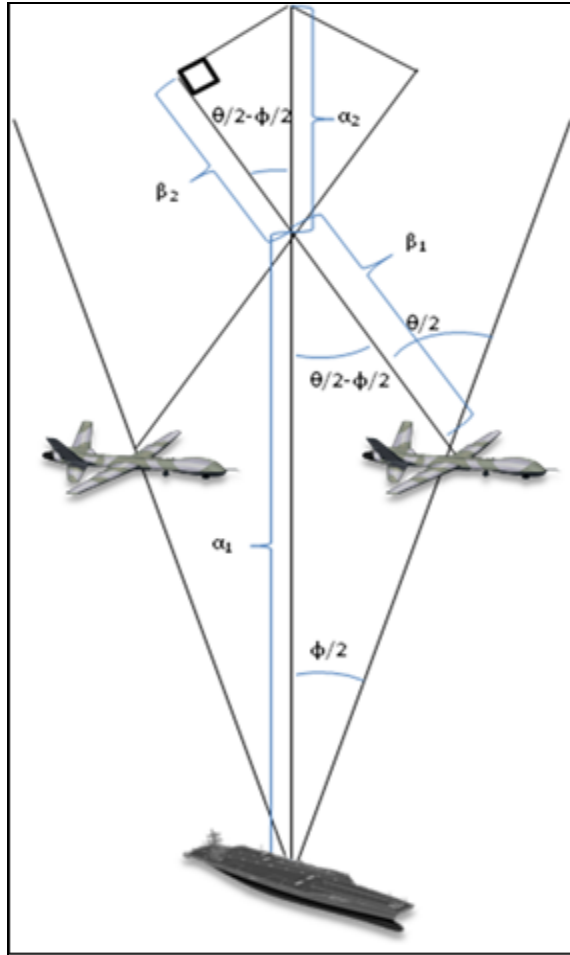

Figure 73. Geometric Analysis of Early Warning Screen

Key Variables

- k Number of UAVs required
- φ Angle between each UAV
- R_{uav} Radius of circle that each UAV orbits around the ABG
- R_{per} Radius of circle for effective detection of the UAV system

Mathematical Equations

$$\frac{\sin(90^\circ)}{\alpha_1} = \frac{\sin(90^\circ - (\theta/2 - j/2))}{\beta_1}$$
$$\beta_1 = \alpha_1 \sin(90^\circ - (\theta/2 - j/2))$$
$$\beta_1 = \alpha_1 \cos(\theta/2 - j/2)$$

$$\frac{\sin(180^\circ - \theta/2)}{\alpha_2} = \frac{\sin(j/2)}{\beta_2}$$
$$\beta_2 = \alpha_2 \frac{\sin(j/2)}{\cos(\theta/2)} = R_d - \beta_1$$
$$\beta_1 = R_d - \alpha_2 \frac{\sin(j/2)}{\cos(\theta/2)}$$

$$\alpha_1 = V_m T_{\min,1}$$
$$\alpha_2 = R + \left(\frac{R}{V_{amm}} + T_{\min,2} \right) V_m$$

$$k = \text{Round Up} \left[\frac{360}{\phi} \right]$$

Parameters Used

V_{amm}, V_m	Mach 4
R	60 km
R_d	30 km
θ	100°
$T_{\min,1}$	1 second
$T_{\min,2}$	15 second

5.7.2.3. Results and Sensitivity Analysis

Numerical methods were used to solve for k , yielding $k = 15$ for the baseline R_d of 30 km and $T_{min,1}$ of 1 sec. Further sensitivity analysis was conducted to vary R_d and $T_{min,1}$. R_d was varied from 20 to 40 km, while T_{min} given a range of 1 to 4 secs. The results are presented in [Table 26](#). k ranges from a low of 12 to 27. This range of k is used for Modeling Phase II to determine the UAV fleet size.

		$T_{min,1}$						
		1	1.5	2	2.5	3	3.5	4
R_d	20	23	24	24	25	26	26	27
	22.5	20	21	22	22	23	23	24
	25	18	19	19	20	20	20	21
	27.5	17	17	18	18	18	18	19
	30	15	16	16	16	16	17	17
	32.5	14	15	15	15	15	15	16
	35	13	14	14	14	14	14	15
	37.5	12	12	13	13	13	13	14
	40	12	12	12	12	12	12	13

TABLE 26. VARIATION OF K UAVS WITH R_D AND $T_{MIN,1}$.

5.7.3. Modeling Phase II: Determine Fleet Size

5.7.3.1. Overview

Model II is a discrete event simulation taking the finite endurance and failure rates of the UAV platform and sensors into consideration when determining the fleet size. A fleet scheduling methodology is called upon to determine the minimum fleet size required.

5.7.3.2. Description

In order to have a persistent early warning screen of UAVs, flight operations will need to take into account several key events. Each UAV has a finite endurance, and will need to land to refuel and be readied for the next mission (a “turnaround”, which also includes the necessary preventive maintenance tasks). During flight, if a failure of a mission critical component occurs, the UAV will need to cut its

time of station and return to base to have the failed component fixed or replaced. The repair requires additional time which consequently extends the turnaround time to be ready for the UAV's next mission. The turnaround time will vary with the workload of the ground-crew and repair times will vary with the complexity of the task. Model II accounts for both variations. [Figure 74.](#) illustrates the operating schedule required to sustain a single aerial picket station.

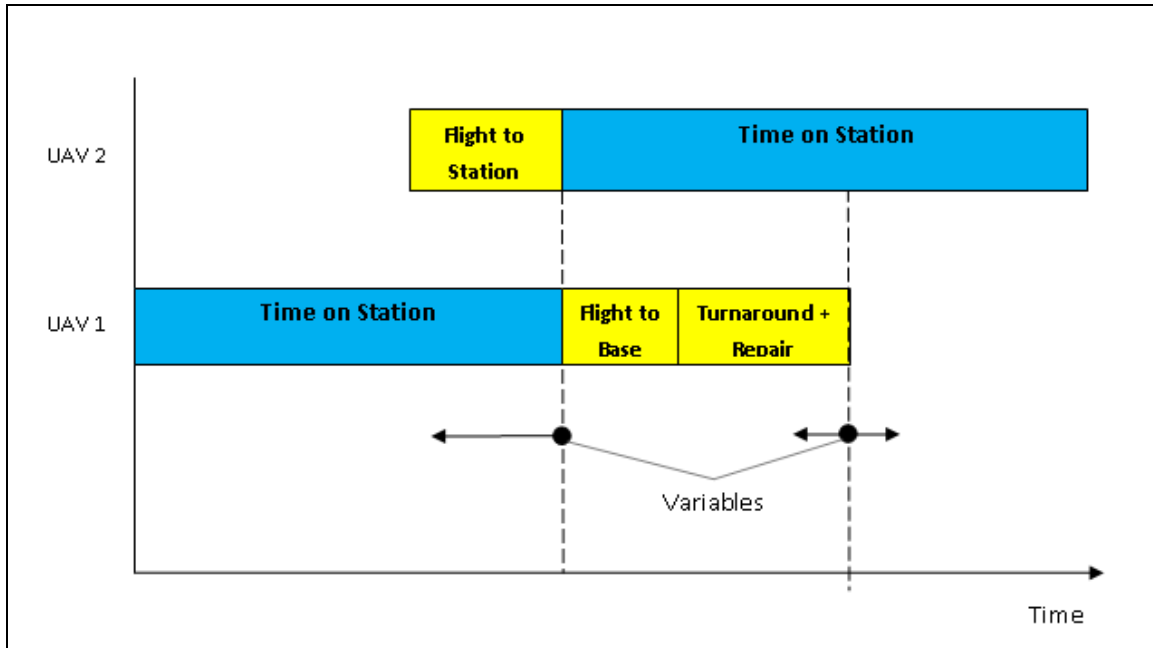

Figure 74. Sample Scheduling of UAVs for a Single Aerial Picket Station

5.7.3.3. Formulation

The schedule from [Figure 74.](#) is extended to k UAVs (determined in Model I), and the events were simulated in SimKit using the event graph depicted in [Figure 75.](#)

A description of which is as follows:

1. UAVs are launched at intervals of one hour (the travel time). The time of launch is recorded and the remaining operation time is calculated to determine if the UAV will fail during flight on route to the patrolling position.

2. Patrolling starts, and another UAV is scheduled to replace the current UAV.
3. Turnaround (refuel and regular maintenance) is scheduled upon return to carrier, with the maintenance time assigned randomly from a triangular distribution.
4. The UAV is ready for launch, with clocked operation hours recorded.
5. If the UAV encounters a mission critical failure at any point of the mission, it will immediately return to the carrier for repairs, triggering an immediate launching of a mission replacement.
6. The repairs are carried out immediately with a random (triangular distribution) repair time, followed by the turnaround.
7. Repaired UAVs are added to the standby storage with all parameters reset as in a new UAV.

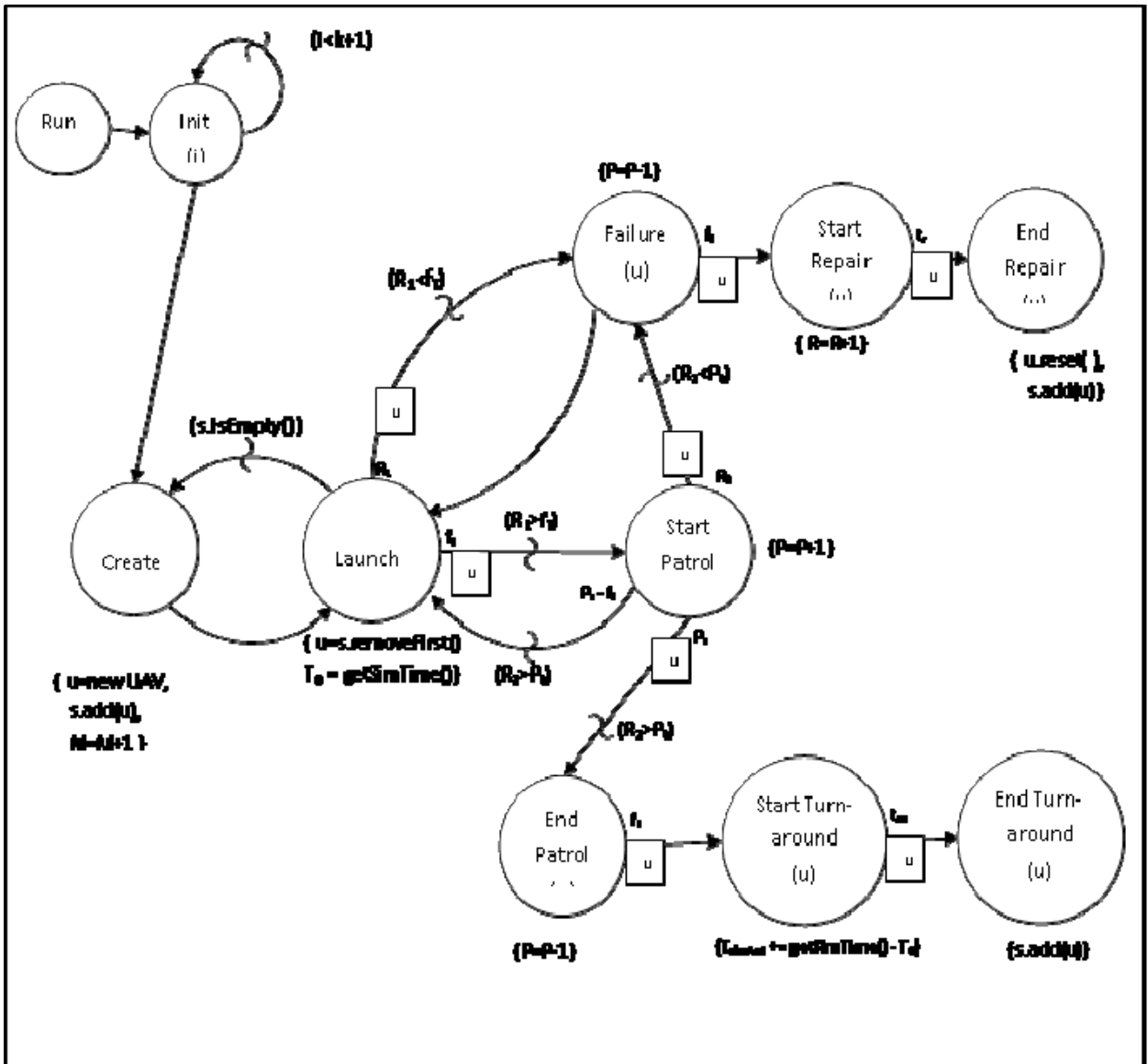

Figure 75. Event Graph for the Scheduling Model in SimKit

Parameters and Variables

- k – number of aerial picket stations from Model I
- s – container representing a spare storage of the ready-to-launch UAVs in standby
- M – number of UAVs required to support the whole operations sequence

- P – counter to keep track of the number of UAVs in active patrol mission. (This provided a means to measure the up time of the detection circle.)
- R – counter to keep track of the total repairs made throughout a operation cycle
- f_T – flight time of a UAV from the launching platform to patrolling station. (Fixed as flight to position is the radius of the patrolling circle. Currently, assumed as $113.5\text{km} \div 217\text{km/h} = 0.523\text{hr}$)
- T_D – record of time that the UAV is launched for mission.
- P_t – maximum patrol time. (Calculated based on 46 hours of max endurance of the UAV and 0.523hr of single way flight time to patrol position. $P_t = 46 - (2 \times 0.523) = 44.954\text{hr}$)
- T_{clocked} – Cumulative time that the UAV have operated in flight.
- R_1 – Calculation of the remaining time before failure occurs. (This value is used to determine if UAV will fail during flight to position. Calculated based on $R_1 = \text{TTF} - T_{\text{clocked}}$)
- R_2 – Calculation of the remaining time allowed for the rest of the patrolling mission. (This value is used to determine if UAV will fail during patrol mission. Calculated based on $R_2 = \text{TTF} - T_{\text{clocked}} - f_T$)
- t_r – Randomly generated repair time of the UAV on failure. Assuming a triangle distributed time between a range of 4hours to 8hours with a mode of 5hours.
- t_m – Randomly generated maintenance time of the UAV after each mission completion. Assuming a triangle distributed time between the range of 0.8hours to 2hours with a mode of 1hr

- TTF – The cumulative total time of flight before the UAV encounters a non-catastrophic failure. Assuming a normal distribution of mean 200hours and standard deviation of 60.79. This will provide us a targeted mean time between failure (MTBF) of 200 to be achieved by 2030 and a 5% probability that the Time To Fail (TTF) will be below 100hours of operation.

5.7.3.4. Results

Modeling Phase II determined that a fleet size of 21 ± 1 UAVs is required to achieve the persistent early warning screen, given R_d of 30km and $T_{\min,1}$ of 1 sec. This result is summarized together with sensitivity analysis for R_d of from 20 to 40 km and $T_{\min,1}$ from 1 to 4 sec in [Table 27](#).

[Figure 76](#). shows a surface plot of the same sensitivity analysis, while the box plots in [Figure 77](#). and [Figure 78](#). show the means and standard deviations of the fleet size for $T_{\min,1}$ of 1 and 4 sec, with R_d ranging from 20 to 40km taken over 1000 simulation runs. The deviations from the mean are small (approximately 1) due to the fact that the endurance of the platform is long and the system is reliable (less than 5% failure rate), leading to small variations in the final fleet size. Intuitively, more UAVs are required if the coverage overlap $T_{\min,1}$ is increased.

In conclusion of the analysis and for further discussions of the C2 architecture, a baseline UAV fleet size can be taken to be 21. For a conservative fleet size estimate, given the uncertainties of the coverage overlap and radar detection range, a fleet size of 35 can be used.

Coverage Overlap $T_{\min,1}$ (sec)	Detection Range R_d (km)		
	20	30	40
1	30	21	18
2	31	22	18
4	35	24	19

TABLE 27. FLEET SIZE VARIATION WITH DETECTION RANGE AND COVERAGE OVERLAP.

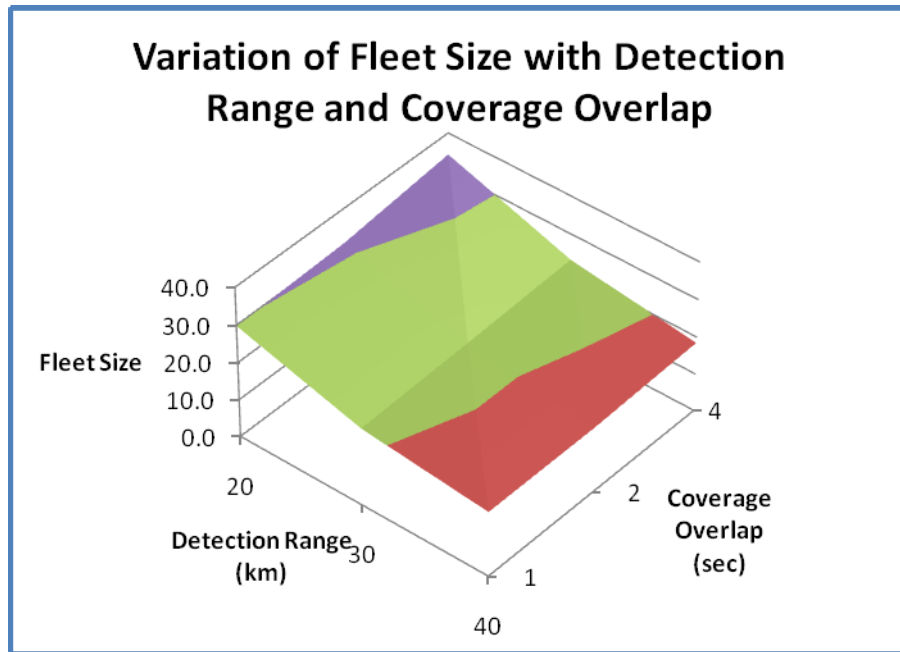

Figure 76. Surface Plot of Variation of Fleet Size

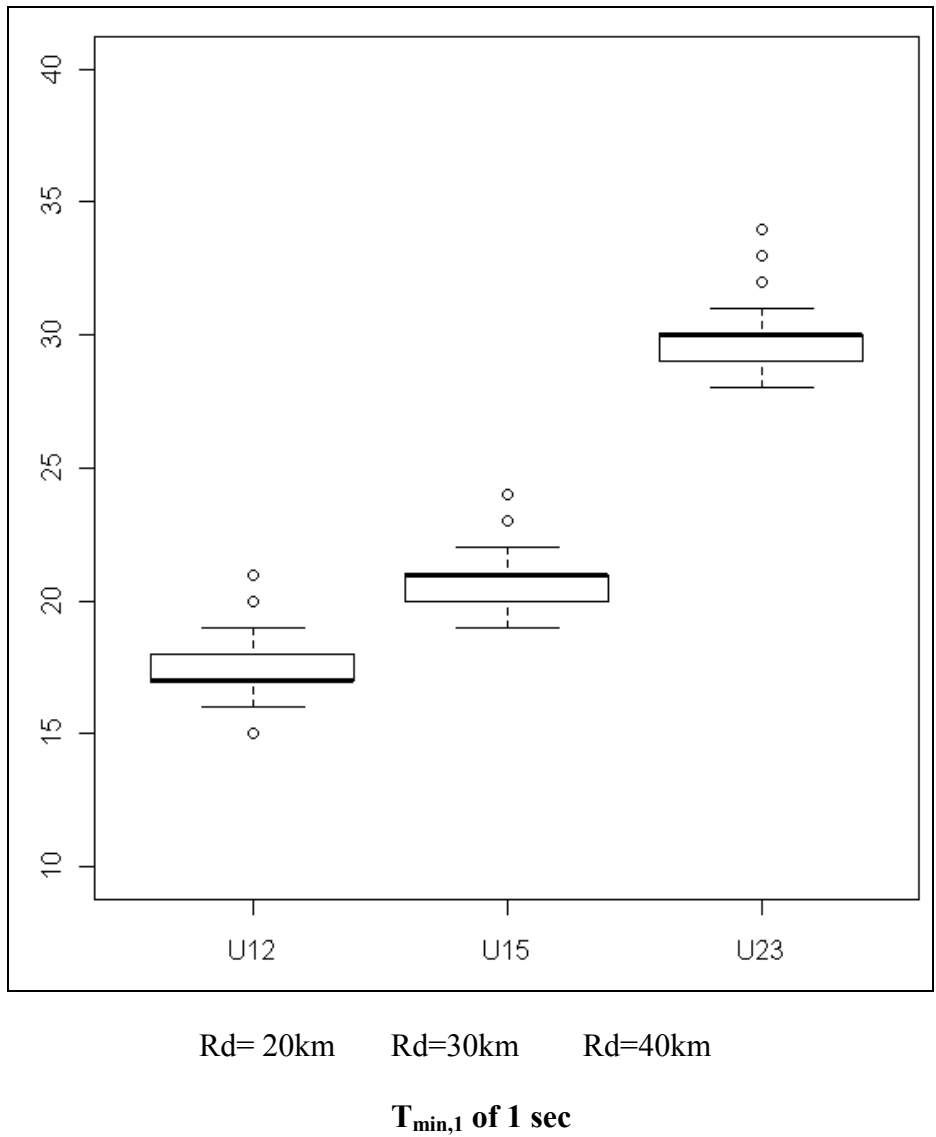
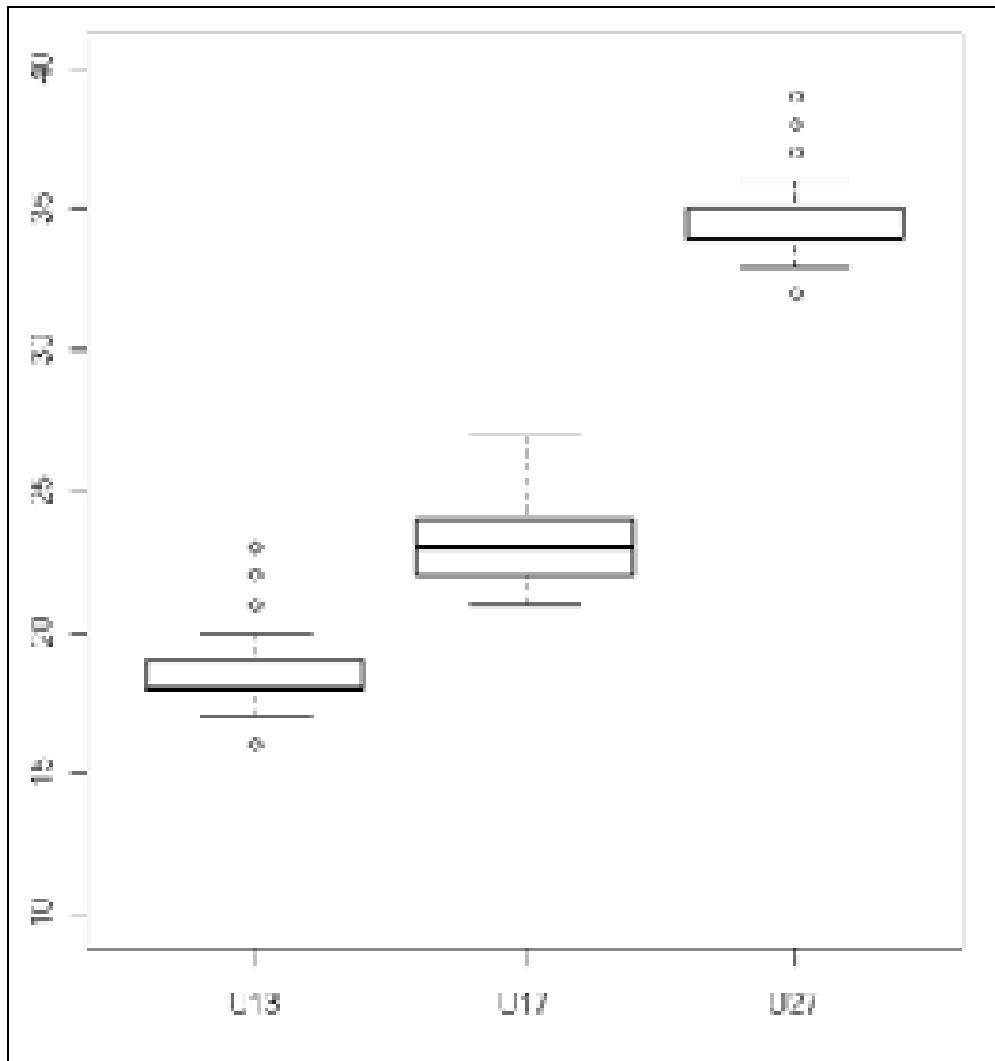

Figure 77. Box Plots of Fleet Size Means and Standard Deviations Size



Rd= 20km Rd=30km Rd=40km

T_{min,1} of 4 sec

Figure 78. Box Plots of Fleet Size Means and Standard Deviations Size

5.8. COMMUNICATION AND NETWORK ANALYSIS

In this operation scenario, the communications and network (CN) systems need to fulfill the following requirements:

- Uplink¹¹³(UL): Air-to-surface platform
 - Data rate: Low, periodic and short
 - Traffic Type:
 - Sensor tracks
 - Telemetry signals
- Downlink (DL): Surface-to-Air platform
 - Data rate: Low, random short-burst
 - Traffic Type:
 - Command & Control signal
- Bi-directional Range: Up to 100km

The current technologies capable of meeting the above requirements are tactical datalink and SATCOM systems.

Tactical datalinks (e.g. Link 16) were built to support real-time collaboration between tactical sensor and shooters in the tactical environment. Link 16 operates on ultra high frequency line-of-sight UHF-LOS band (960-1215MHz). It operates on Time-Division Multiple Access (TDMA) scheme which offers 1536 time-slots per 12 sec frame. The time slots in each frame are partitioned into functional groups called NPGs, e.g. surveillance, air control, fighter-to-fighter net, etc. They are dynamically assigned to user on-demand based on a predefined format.¹¹⁴

¹¹³ This definition is based on Star-topology setup: “Uplink” refers the link from mobile stations to central base station; “Downlink” refers to the link from central base station to mobile stations.

¹¹⁴ *Tadil J: Introduction To Tactical Digital Information Link J And Quick Reference Guide, Fm 6-24.8/ Mcwp 3-25c/ Nwp 6-02.5/ Aftp(I) 3-2.27*, June 30, 2000, <http://www.globalsecurity.org/military/library/policy/army/fm/6-24-8/tadilj.pdf> (accessed June 4, 2010)

To estimate¹¹⁵ the maximum number of sensors that one tactical datalink net can support, the following assumptions were made:

- Let the average **data size** of sensor-feed data be D bytes/track;
- For each target track, let the average **track update rate** be T tracks/second/missile;
- Let the **system throughput capacity of link-16 that is reserved for sensor feed** be C_b bits/sec;
- Let the **number of maximum concurrent missile attacks** expected be M missiles;
- There are maximum of 2 sensors covering and airspace at any instant (**overlapped detection zone**);
- Assuming there are n sensors operating in the AO in ring orbit, the maximum number of sensors datalink can support is:

$$n < \left\lfloor \frac{\text{Capacity reserved for sensor data transmission}}{2 \times M \times \text{Data rate demand per unit per track detected}} \right\rfloor$$

$$n < \left\lfloor \frac{C_b (\text{bit} / \text{s})}{2 \times M \times 8 (\text{bit} / \text{byte}) \times D (\text{byte} / \text{track}) \times T (\text{track} / \text{s})} \right\rfloor$$

For example, assuming the following values for T , C_b , D , and M ; $n = 15$ sensors/net.

- $T = 1$ track/sec
- $C_b = 2400$ bps
- $D = 10$ bytes/track
- $M=1$, the number of sensors supported

¹¹⁵ This estimation shall be based on generic perspective, given the fact that the detailed format for tactical datalink was not available for this study.

To support N x UMS sensor platforms in this scenario, it will require f datalink nets, where:

$$f = \frac{N}{n}$$

From link budget assessment, the tactical datalink is able to support communications link between carrier battle group and the aerial UMS operating 100km range. Hence there is no need to form multi-hop network to relay the track message back to the C2 center. This is displayed in [Figure 79](#).

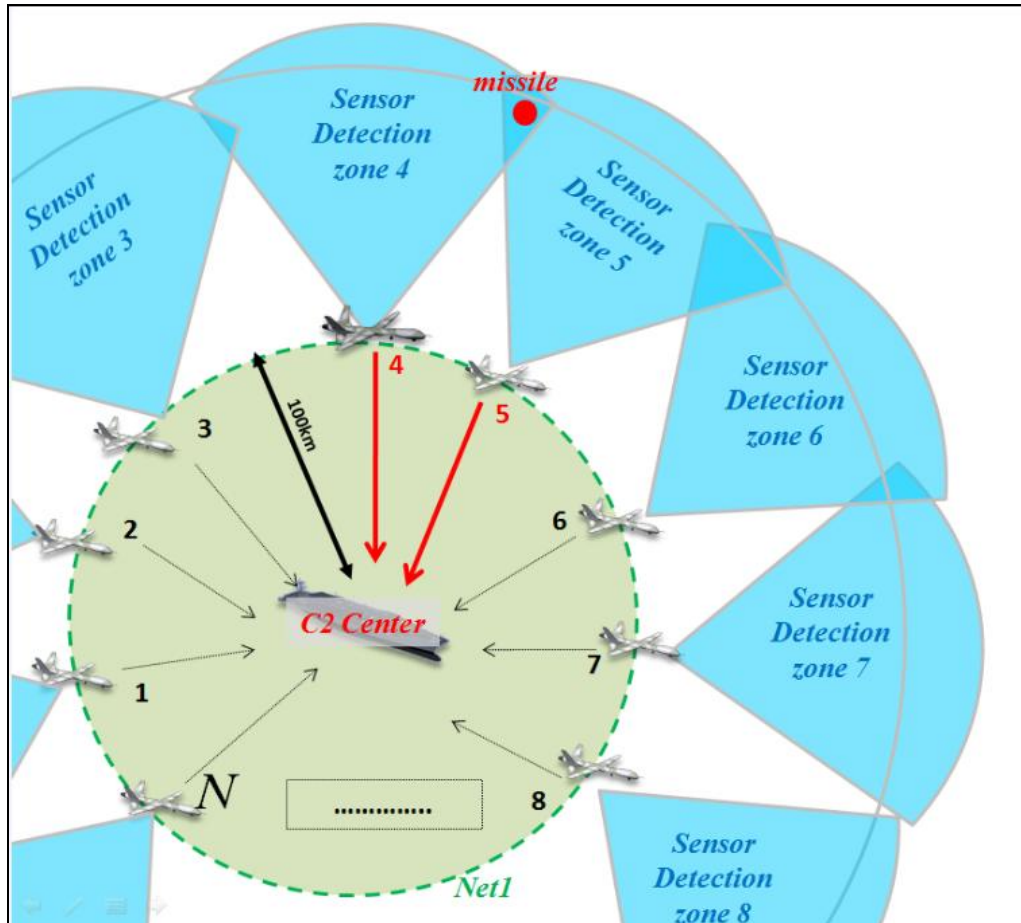

Figure 79. Data traffic generated for every missile entering the Detection Zone

However, if the scenario requires extending the sensor ring radius, as shown in [Figure 80.](#), beyond the range of terrestrial communications coverage, SATCOM offers an alternative reachback link from the orbiting UMS sensor ring to the C2 centre. Despite the fact that SATCOM link has higher latency (approximately 250-300msec for GEO stationary satellite relay) than terrestrial communications system, it is still suitable for transmitting advance warning information detected by the first-line sensors.

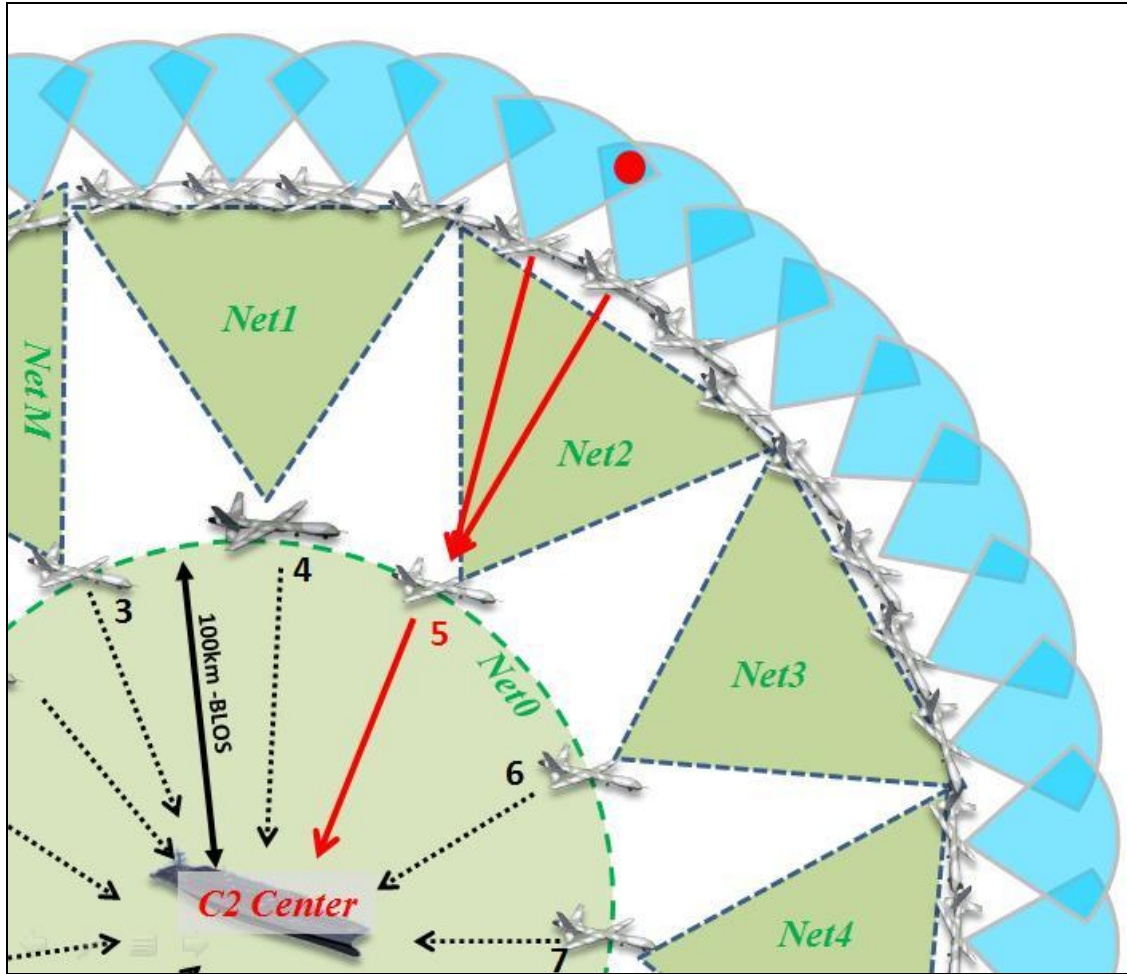

Figure 80. Unmanned Sensor Network Topology (Extended Range)

5.9. RANGE ASSESSMENT: LINK BUDGET FOR SURFACE-TO-AIR COMMUNICATIONS LINK

The tactical class UAV operates at altitudes of 10,000 feet (3.05km) above mean sea level (AMSL) for the payload's ISR capabilities to function optimally within electro-optical (EO) sensor range. In general, the datalink range is limited by the transmission power of the UAV's onboard antenna. Therefore the values of UAV transmission powers is used as a constraints for link margin calculations. Figure 1 shows the fade margins¹ considered at a distance of 100km with transmission powers, P_t of 10, 20, 50 and 100 watts in the line-of-sight (LOS). In the scenario of datalink between the carrier and UAV, as the distance between them increased the fade margin decreases. At the lowest transmission power of 10W the fade margin was at 15dB above the minimum threshold. This suggests that there is sufficient link margin to meet the surface-to-air and air-to-surface duplex link for a single UAV to carrier scenario.

Lacking the technical specifications of radio transmitter and receiver system, the link budget calculations were based on the following estimated assumptions:

- RF carrier frequency, $f_c = 1215\text{MHz}$. (Link-16 Max frequency for UHF-LOS band)
- Receiver system noise temperature of, $T_{sys} = 410\text{K}$;
- Channel Bit-rate, $R_b = 2400\text{bps}$;
- Omni directional antennas with gain, $G_t, G_r = 1\text{dBi}$;
- Transmitter Power, $P_t = 10\text{W}, 20\text{W}, 50\text{W}, 100\text{W}$
- Digital Signal-to-Noise ratio (assume QPSK @ BER $<10^{-5}$), $E_b/N_{0, min} \approx 10\text{dB}$ (See Figure 2);
- Other system losses, $L_{sys} = 3\text{dB}$;
- Channel Loss Model: Free space path loss model, $L_{channel} \propto \frac{1}{R^2}$;
- Boltzmann Constant, $k = 1.38 \times 10^{-23}$ Joules
- Speed of Light, $c = 3 \times 10^8$ m/s

Link budget formula:

$$\begin{aligned}
 \text{Fade Margin} &= \left(\frac{E_b}{N_0} \right)_{\text{received}} - \left(\frac{E_b}{N_0} \right)_{\text{min}} \\
 \left(\frac{E_b}{N_0} \right)_{\text{received}} &= S \left(\frac{R_b}{kT_{\text{sys}}} \right) = \frac{P_t G_t G_r}{L_{\text{channel}} L_{\text{sys}}} \left(\frac{R_b}{kT_{\text{sys}}} \right) \\
 L_{\text{channel}} &= \left(\frac{4\pi f_c R}{c} \right)^2
 \end{aligned}$$

The fade margin is plotted against range, R , to extrapolate the link performance over distance. This graph can be found in [Figure 81](#).

Fade margin represents the received RF power above the minimum threshold level at a specified bit-error rate (BER) performance. This graph can be found in [Figure 82](#).

In the ideal environment, the received power derived from the link budget is deemed adequate (given that fade margin $> 0\text{dB}$) to maintain a reliable link (BER $< 10^{-5}$) at 100km range. However, in the real environment, the link is subjected to multipath fading, e.g. the ship superstructure presents multiple reflection surfaces to the radio wave that is emitted from omni-directional antenna. The random mix of multiple signals arriving at the receiver via different reflection paths results in random construction and destruction of RF wave at the receiver. The signal level at the receiver drops when the resultant waves are destructive. Additional fade margin has to be factored into the link budget requirement to maintain the desired the link quality. The mitigation methods to reduce multipath fading are as follow:

- Raise the height of the antenna on the ship: This reduces the multipath fading caused by the planar surfaces of the ship superstructure.
- Multiple-Input Multiple-Output (MIMO) technology: Space-time coding leverages on spatial diversity and time diversity to reduce the effect of multipath fading.
- Increase transmission power to increase the fade margin: This approach is limited by the finite payload capacity of the platform.

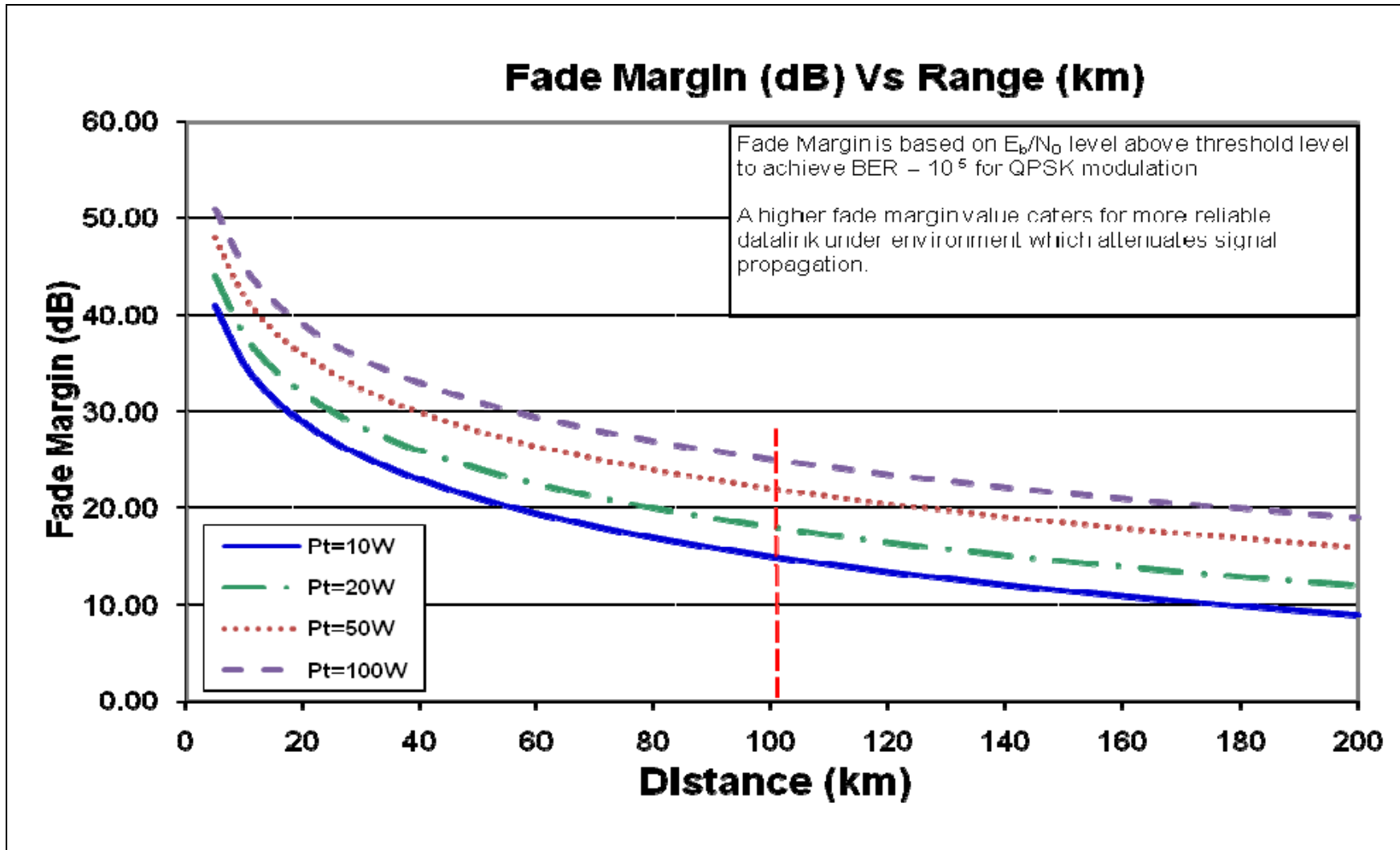

Figure 81. Fade Margin (dB) is inversely proportional to R^2 as the R between Transmitter & Receiver increases

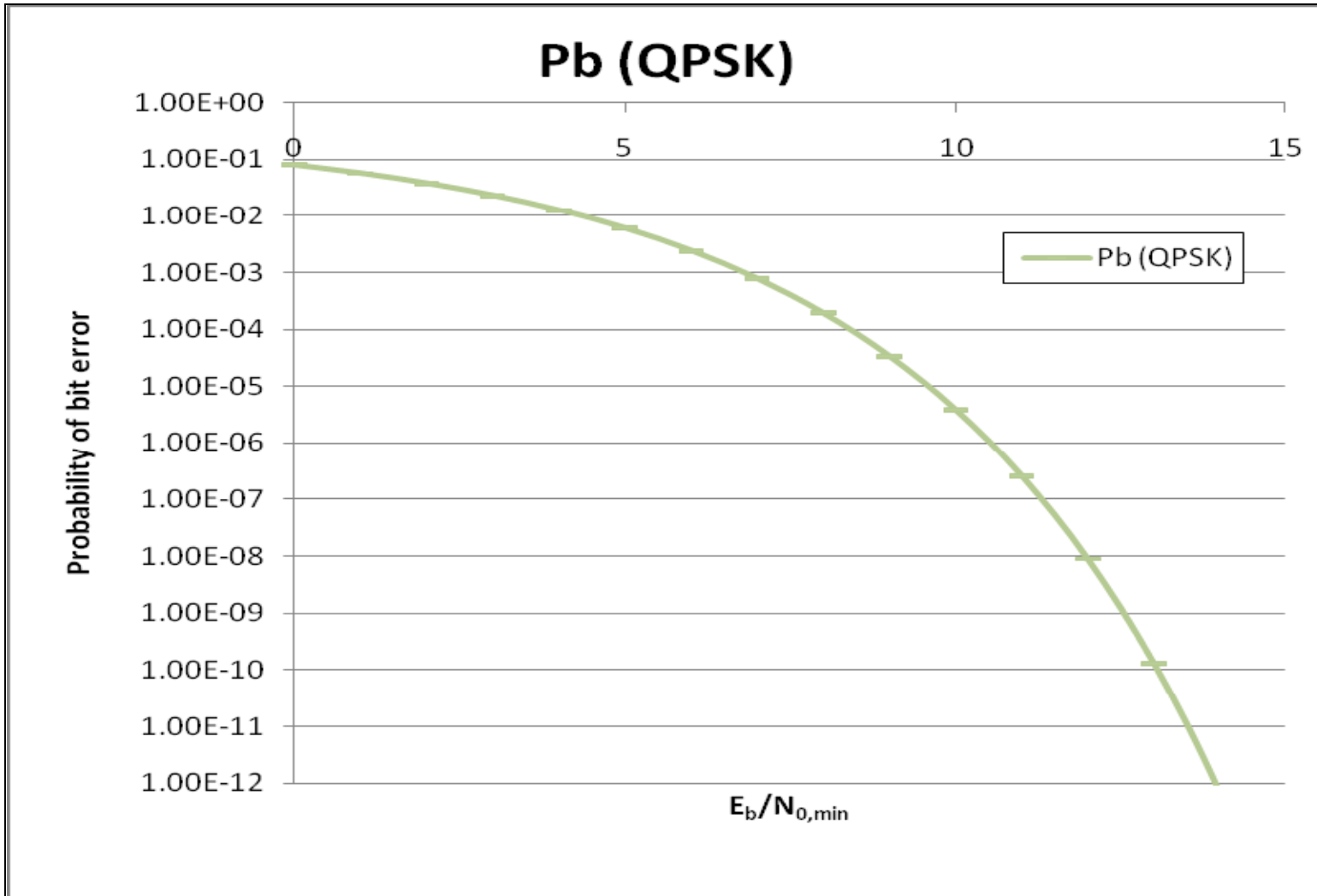

Figure 82. Probability of bit error (BER) vs E_b/N_0

THIS PAGE INTENTIONALLY LEFT BLANK

6.0. RESULTS

6.1. SUMMARY OF RESEARCH

A Command and Control Architecture that integrates manned and unmanned systems will be necessary by 2030. The proposed architectural concept is meant to be a guide towards realizing this capability. The key will be to develop technology and doctrine promotes timely, accurate, and appropriate information is available to the warfighter. This information must cross all mediums to be available to the force elements that would benefit from that data, whether they are in the local area, or operating remotely through a global interface.

Integrated Project Teams and specialized Track Teams conducted studies on several factors, specifically outlining levels of systems autonomy, examining the roles of humans and machines in systems, examining critical information assurance considerations, and technical evolution of unmanned vehicle technology.

A functional architecture was developed along with several command and control architecture products. The functional architecture, described in terms of Boyd's OODA Loop, describes the actions that must be taken by the system to conduct operations. The High Level Operational Concept Graphic illustrated the general operation of the system and highlighted its features within the 2030 battlespace. The Operational Node Connectivity Description showed the connectivity and information flow between operational nodes for Force Protection and Reconnaissance. The Information Exchange Model showed the typical flow of information between nodes in an operational setting. Information Exchanges for the system were identified through several matrices. The Operational Activity Models showed the activities, relationships among activities, inputs and outputs of the different system nodes. The High Level Conceptual System View presents a layered approach for building the system.

Architecture concepts were applied to one of the innumerable potential operational applications for unmanned vehicles. Our model depicted the deployment of unmanned vehicles to provide the carrier battle group with early detection of an ASCM.

The force needed to complete the layout of forces was geometrically evaluated to provide necessary stations given overlapping coverage, and a discrete event simulation was used to determine the need for 21 unmanned vehicles to maintain operation of these stations given the assumed parameters. To relate this model to the architecture capacity, the relationship between the number of vehicles and network requirements was determined.

6.2. RECOMMENDATIONS

Based on Boyd's Observe, Orient, Decide and Act (OODA) Loop the Functional Decomposition of Command and Control was developed to provide (1) the basic functions required for UMS and (2) an extensive assessment of UMS mission domain. To satisfy the needs for the battlespace of 2030, recommendations for technology developments and changes in the organization and joint doctrine were posed.

6.2.1. Actions Needed Prior to 2030

Technology development:

- Radar Receiver Technology - Improvements in detection range and detection of Sea Skimming Missiles.
- Signal Processing Technology - Improvement in detection range and detection of Sea Skimming Missiles.
- Improvement in Very Large Scale Integration (VLSI) technology - Improvement in processing power.
- Materials Research - Light weight materials to reduce the weight of UVs.
- Power Generation - Improvement in power generation per unit weight.
- Prevention of Electromagnetic Interference - EMI will be an issue as more sensors are packed into an integrated payload. More research is required to minimize this effect & prevent the jamming of own forces' signals.
- Common Sensor Data Format - With the advent of more sensor types on a single UMS, a common sensor data exchange format needs to be standardized in order to optimize the amount of information exchange between unmanned & manned platforms & prevent incompatibility.

- Sensor Fusion- Majority of the sensor fusion is currently done after raw data are sent back to HQ. An improvement in digital signal processing speed will allow such sensor fusion to take place at the front end (UMS). This will minimize the amount of sensor data to be sent back & hence reduce bandwidth requirements.
- Increase the Size of Imaging Array—to increase the capacity of EO sensors to have sufficiently broad fields of view and resolution. This will then allow detection of entities at long ranges so that sophisticated image interpretation techniques can perceive and “understand” the key elements in the environment.

Required organizational actions:

- Generate an official Joint Operational Concept in accordance with Chairman Joint Chief of Staff Instruction 3010.02B, *Joint Operations Concept Development Process*.
- Develop doctrine, in coordination with coalition forces, for operations involving integrated manned and unmanned systems.
- Parallel technology development with coalition forces.
- Promote common standards for interoperability between US and allied nations.
- Encourage industry to develop common control console for unmanned vehicles of all mediums.
- Invest in information systems personnel to develop a technically savvy force.
- Continue to improve the transfer of data through enhancements to tactical data networks.

6.3. FUTURE AREAS OF STUDY

Many of the concepts for future battlespace engagements are in their infancy today. This research project helped identify some of these concepts. Below are listed a few that were deemed essential next steps to further the interactions between unmanned and manned vehicles as well as their overall joint operations.

- Optimal balance between manned and unmanned systems to accomplish future missions.
- Self healing, self forming networks.
- Required organizational changes in the DoD to manage the increase usage of unmanned systems.
- Logistics required to support future manned and unmanned system force structure.
- Maintenance concept for future unmanned force.
- Suitability of unmanned systems being deployed from the expected military platforms of 2030.
- Legal issues arising from use of unmanned vehicles.

7.0. GLOSSARY, ACRONYMS, AND ABBREVIATIONS

7.1. GLOSSARY

Architecture: “a framework or structure that portrays relationships among all the elements of the subject force, system, or activity.”¹¹⁶

Capability: the ability to execute a specified course of action. (A capability may or may not be accompanied by an intention)

Capability Based Assessment: the portion of the JCIDS analysis that identifies capability and supportability shortfalls, gaps, and redundancies on specific capability needs. CBAs generally consist of three parts: the Functional Area Analysis (FAA), Functional Needs Analysis (FNA) and the Functional Solution Analysis (FSA). Results of FAA and FNA are documented in the Joint Capabilities Document.

Capstone: the crowning achievement, point, element, or event.¹¹⁷

Collection Management Authority: Constitutes the authority to establish, prioritize, and validate theater collection requirements, establish sensor tasking guidance, and develop theater collection plans.

Collection Operations Management: The authoritative direction, scheduling, and control of specific collection operations and associated processing, exploitation, and reporting resources.

Condition: a variable of the operational environment that may affect task performance. Physical conditions pertain to the material environment: weather, climate, geography, and terrain. Military conditions are those characteristics of the equipment upon which the performance of desired military functions depend

¹¹⁶ Department of Defense, Department of Defense Dictionary of Military and Associated Terms, Joint Publication 1-02 (12 April 2001, as amended through 19 August 2009).

¹¹⁷ Capstone, available from <http://dictionary.reference.com/>, accessed 17 February 2010.

Data: Data will incorporate the following items under the name “Data”: Data, Voice, and Video information that is transmitted between a Control Center and an Unmanned System.

Discipline: a branch of knowledge; as used in this document, discipline refers to a particular type of intelligence: HUMINT, IMINT, SIGINT, MASINT, OSINT, etc.

Domain: a location environment; as used in this document, domain refers to either maritime, aerospace, terrestrial, etc.

Intelligence Community: a federation of executive branch agencies and organizations that conduct intelligence activities necessary for conduct of foreign relations and protection of national security including: CIA, DIA, NRO, NSA, NGA, State Dept, Treasury, DHS, DEA, FBI, Energy, Service Intel Organizations (Army, Navy, Air Force, Marines, Coast Guard).

Intelligence, Surveillance, and Reconnaissance (ISR): an activity that synchronizes and integrates the planning and operation of sensors, assets, and processing, exploitation, and dissemination systems in direct support of current and future operations, an integrated intelligence and operations function.

Integrated:

1. combining or coordinating separate elements so as to provide a harmonious, interrelated whole: *an integrated plot; an integrated course of study*
2. organized or structured so that constituent units function cooperatively: *an integrated economy.*
3. having, including, or serving members of different racial, religious, and ethnic groups as equals: *an integrated school.*¹¹⁸

Integrated Management: Creation of a military force that operates by engaging as a whole through processes including, but not limited to: strategic planning, setting

¹¹⁸ Integrated, available from <http://dictionary.reference.com/>, accessed 17 February 2010.

objectives, managing resources, deploying human and technical assets needed to achieve objectives, and measuring results.

ISR Enterprise: Those defense organizations, resources, and personnel assigned responsibilities for executing any part of the intelligence mission. The ISR Enterprise includes a core set of organizations and resources that have intelligence as a primary function. The ISR Enterprise may include other resources providing information of intelligence value under command and control arrangements specified by the Combatant Commander, JFC, or subordinate/component commander.

ISR Resource: Any asset that collects, processes, exploits, analyzes, or manages data that is used within the intelligence process. These resources are not necessarily "intelligence" resources, and may have a primary mission other than intelligence.

Joint Force Commander: A general term applied to a Combatant Commander, sub-unified commander, or joint task force commander authorized to exercise combatant command or operational control over a joint force.

Low Density/High Demand: LD/HD assets are defined as certain limited assets/forces with unique mission capabilities stressed by continual high OPTEMPO because of JFC requirements. Assets are governed by steady-state and surge capabilities defined in the Global Military Force Policy (GMFP). Steady-state is defined as the maximum peacetime deployment capability that can be sustained indefinitely with no adverse impact. Surge is defined as an additional level of deployment that can be sustained for a limited period with some adverse impact. (After a period of surge, a defined recovery period at or below steady-state is required.) The SECDEF must approve any deployment that forces an LD/HD asset into surge status.

Persistence: the length of time a sensor can provide continuous coverage of a location, target, or activity of interest. The JFC's desire for persistence is founded upon his inability to satisfy CCIRs, PIRs, or EEIs, with the current ISR Enterprise due to problems or obstacles generated by friendly and/or adversary actions or capabilities. What

constitutes persistence varies significantly dependent upon JFC mission objectives, operating environment, and target type.

Standard: quantitative and qualitative measures for specifying the levels of performance of a task.

System: is a “set of components (subsystems, segments) acting together to achieve a set of common objectives via the accomplishment of a set of tasks.”¹¹⁹

Systems Engineering: Systems Engineering is an interdisciplinary approach and means to enable the realization of successful systems. It focuses on defining customer needs and required functionality early in the development cycle, documenting requirements, then proceeding with design synthesis and system validation while considering the complete problem:

Operations	Cost & Schedule
Performance	Training & Support
Test	Disposal
Manufacturing	

Systems Engineering integrates all the disciplines and specialty groups into a team effort forming a structured development process that proceeds from concept to production to operation. Systems Engineering considers both the business and the technical needs of all customers with the goal of providing a quality product that meets the user needs¹²⁰

Systems Architecture: An architecture deals with a top-level system structure (configuration), its operational interfaces, anticipated utilization profiles (mission

¹¹⁹ Buede, Dennis M., The Engineering Design of Systems: Models and Methods. John Wiley & sons, New York, NY, 2000, p. 440.

¹²⁰ Systems Engineering, available from <https://www.incose.org>, accessed 14Jan 2010

scenarios), and the environment within which it is to operate; then it describes how these various requirements for the system interact.¹²¹

Task: an action or activity (derived from an analysis of the mission and concept of operations) assigned to an individual or organization to provide a capability.

7.2. ACRONYMS

AAI	Aircraft Armaments, Inc
ACN	Aerial Communications Network
AIP	Air Independent Propulsion
AO	Area of Operations
AoA	Analysis of Alternatives
AFO	Advance Force Operations
AFRL	Air Force Research Laboratory
ALFUS	Autonomy Levels for Unmanned Systems
AOE	Automated Ordnance Excavator
AOR	Area of Responsibility
ASCM	Anti-Ship Cruise Missile
ASTM	American Society of Tests and Materials
ATDC	After Top Dead Center
AUV	Autonomous Unmanned Vehicle
AUVS	Association for Unmanned Vehicle Systems
AUVSI	Association for Unmanned Vehicle Systems International

¹²¹ Blanchard, 2006.

BA	Battlespace Awareness
BAE	British Aerospace Systems
BDA	Battle Damage Assessment
BFT	Blue Force Tracking
BIT	Built in Test
BLOS	Beyond Line of Sight
BPAUV	Battlespace Preparation Autonomous Undersea Vehicle
BPD	Barrels per Day
BTDC	Before Top Dead Center
BULS	Bottom (UUV) Localization System
C2	Command and Control
C2AFT	Command and Control Architecture Task Force
C3	Command, Control, and Communications
C4	Command, Control, Communications and Computers
C4I Intelligence	Command, Control, Communications, Computers and Intelligence
C4ISR	Command, Control, Communications, Computers and Intelligence, Surveillance, and Reconnaissance
CARACaS Sensing	Control Architecture for Robotic Agent Command and Sensing
CAT	Crew-Integrated and Automation Test-bed
CBA	Capabilities Based Assessment
CBP	Capabilities Based Planning
CBR	Chemical, Biological, Radiological
CCDD	Cover, Concealment, Deception, Denial
CCIR	Commander's Critical Information Requirements

CCJO	Capstone Concept for Joint Operations
CDS	Common Data Standards
CES	Commander's Estimate of the Situation
CIA	Central Intelligence Agency
CIA	Confidentiality, Integrity, and Availability
CIO	Chief Information Officer
CN	Communications Network
CNS	Communications, Network, and Sensors Track
COA	Course of Action
COBRA	Combine Operations Battlefield Robotic Asset
COCOM	Combatant Command
COIN	Common Operator Interface Navy
COLREGS Sea	Coast Guard International Rules for Avoiding Collisions at Sea
CONOPS	Concept of Operations
COTS	Commercial Off the Shelf
COUGAR	Cooperative Unmanned Ground Attack Robots
CSAR	Combat Search and Rescue
CVBG	Carrier Battle Group
CVC	Constant Volume Combustion
D.Sc.	Doctor of Science
DAMA	Dynamic Assigned Multiple Access
DARPA	Defense Advanced Research Projects Agency
DBA	Dominant Battlespace Awareness
DEA	Drug Enforcement Agency

DHS	Department of Homeland Security
DIA	Defense Intelligence Agency
DNI	Director of National Intelligence
DoD	Department of Defense
DoDD	Department of Defense Directive
DOE	Department of Energy
DOS	Department of State
DOTMLPF	Doctrine, Organization, Training, Materiel, Leadership and Education, Personnel, Facilities
EC	Environmental Complexity
EO	Electro-Optical
EOD	Explosive Ordnance Disposal
EEI	Essential Elements of Information
EM	Electromagnetic
EPA	Environmental Protection Agency
ESM	Electronic Support Measures
EW	Electronic Warfare
F-T	Fischer-Tropsch
FA	Force Application
FAA	Functional Area Analysis
FAA	United States Federal Aviation Administration
FBI	Federal Bureau of Investigation
FCB	Functional Capabilities Board
FFBD	Functional Flow Block Diagram
FINDER	Flight Inserted Detection Expendable for Reconnaissance

FL	Focused Logistics
FM	Force Management
FNA	Functional Needs Analysis
FOPEN	Foliage Penetration
FSA	Functional Solution Analysis
GH	GLOBAL HAWK
GMFP	Global Military Force Policy
GSEAS and Applied Sciences	Naval Postgraduate School Graduate School of Engineering
GSOIS	Graduate School of Operations and Information Sciences
GWOT	Global War on Terrorism
HADR	Humanitarian Assistance Disaster Relief
HALE	High Altitude Long Endurance
HAPS	High Altitude Platform Station
HDF	High Definition Format
HDW	Howaldtswerke-Deutsche Werft
HECC	High Efficiency Clean Combustion
HFE	Hidden Field Equations
HI	Horizontal Independence
HI	Human Integration
HLS	Homeland Security
HMCDM	Human Machine Collaboration Decision Making
HQ	Headquarters
HRI	Human Robot Interface
HUMINT	Human Intelligence

HVU	High Value Unit
HWV	Heavy Weight Vehicle
IA	Information Assurance
IC	Intelligence Community
ICAO	International Civil Aviation Organization
IED	Improvised Explosive Devices
IFF	Identification Friend or Foe
IFR	Instrument Flight Rules
IMINT	Imagery Intelligence
IPL	Integrated Priority List
IPR	In-Process Review
IPT	Integrated Project Team
IR	Infrared
ISAR	Inverse Synthetic Aperature Radar
ISR	Intelligence, Surveillance, and Reconnaissance
ISTAR Reconnaissance	Intelligence, Surveillance Target Acquisition and
I&W	Indications and Warning
JAUS	Joint Architecture for Unmanned Systems (NASA developed used on the Mars Rovers. Intelligent Autonomy Engine)
JCA	Joint Capability Area
JFC	Joint Force Commander
JIATF	Joint Interagency Task Force
JIC	Joint Integrating Concept
JIPOE Environment	Joint Intelligence Preparation of the Operational

JOpsC	Joint Operations Concepts
JP	Joint Publication
JPL	Jet Propulsion Lab
JROC	Joint Requirements Oversight Council
JTF	Joint Task Force
LBSAUV Vehicle	Littoral Battlespace Sensing Autonomous Underwater
LCS	Littoral Combat Ship
LD/HD	Low Density/High Demand
LiFePO ₄	Lithium Iron Phosphate
LOC	Lines of Communication
LOE	Limited Objective Experiment
LPD	Low Probabilty of Detection
LPI	Low Probabilty of Interference
LWV	Light Weight Vehicle
M-HLS/D	Maritime-Homeland Security/Defense
MANET	Mobile Adhoc Network
MASINT	Measures and Signature Intelligence
MATILDA Deployment Assembly	Mesa Associates' Tactical Integrated Light-Force
MAV	Micro Air Vehicle
MC	Mission Complexity
MCM	Mine Counter Measures
MCO	Major Combat Operations
MDARS	Mobile Detection, Assessment and Response System

MEDAL	Mine Warfare and Environmental Decision Aids Library
MEDAL-EA Enterprise Architecture	Mine Warfare and Environmental Decision Aids Library -
MESF	Maritime Expeditionary Security Force
MIMO	Multiple Input Multiple Output
MIW	Mine Warfare
MLS	Multi-level Security
MOE	Measures of Effectiveness
MOLLE	Modular, Light Weight, Load Carrying Equipment
MOOTW	Military Operation Other Than War
MOP	Measures of Performance
MOVES Naval Postgraduate School,	Modeling, Virtual Environments, and Simulation Institute Monterey, CA, USA.
MTBF	Mean Time Between Failures
MTRS	Man Transportable Robotic System
N8F	Director of Warfare Integration
N-UCAS	Navy-Unmanned Air Combat System
NARPV	National Association of Remotely Piloted Vehicles
NASA	National Aeronautical and Space Agency
NATO	North Atlantic Treaty Organization
NAVAIR	Naval Air Systems Command
NCE	Network Centric Environment
NCOE	Network Centric Operating Environment
NECC	Naval Expeditionary Combat Command
NGA	National Geospatial Intelligence Agency

NiMH	Nickel Metal Hydride
NOAA	National Oceanographic and Atmosphere Administration
NPS	Naval Post Graduate School, Monterey, California, USA
NRL	Naval Research Lab
NRO	National Reconnaissance Office
NSA	National Security Agency
NSAM	Net-Centric Sensor Analysis for MIW
NUS	National University of Singapore
NWDC	Naval Warfare Development Group
OMTF	Operations Research and MOVES Task Force
ONR	Office of Naval Research
ONIR	Overhead Non-imaging Infrared
OODA	Observe, Orient, Decide, and Act
OPE	Operational Preparation of the Environment
OPNAV	Office of the Chief of Naval Operation
OPSIT	Operational Scenario
OPTEMPO	Operating / Operations Tempo
OR	Operations Research
OSINT	Open Source Intelligence
OV	Operational View
PDE	Pulse Detonation Engine
PEM	Polymer Electrolyte Membrane
PEO	Program Executive Office
PIR	Prioritized Intelligence Requirement
PLAN	People's Liberation Army Navy (China)

PMA	Post Mission Analysis
PMA	Program Manager Air
PMS	Program Manager Surface
PNT	Positioning, Navigation, and Timing
POTUS	President of the United States
PRC	People's Republic of China
PWBS	Project Work Breakdown Structure
R & D	Research and Development
RCS	Radar Cross Section
REDCAR	Remote Detection, Challenge, and Response System
RF	Radio Frequency
RPV	Remotely Piloted Vehicle
RJ	RIVET JOINT
ROE	Rules of Engagement
ROMO	Range of Military Operation
RONS	Remote Ordnance Neutralization System
RTB	Return to Base
S & T	Science and Technology
SAR	Search and Rescue
SAR	Synthetic Aperture Radar
SATCOM	Satellite Communications
SECDEF	Secretary of Defense
SEAL	Sea, Air, and Land
SCI	Sensitive Compartmented Information
SD	Strategic Deterrence

SE	Systems Engineering
SEA	Systems Engineering and Analysis
SEMP	Systems Engineering Management Plan
SEP	Systems Engineering Plan
SIGINT	Signals Intelligence
SJFHQ	Standing Joint Force Headquarters
SO	Stability Operations
SOF	Special Operating Forces
SRR	Short Range Radar
SSOC	SEA-16 Organizing Committee
SSTR	Security, Stabilization, Transition and Reconstruction
STANAG	Standardized Agreement
SV	Systems View
TCP/IP	Tactical Communication Protocol/Internet Process
TCR	Target Clutter Ratio
TDSI	Temasek Defence Systems Institute
TOC	Tactical Operations Center
TPED	Tasking, Processing, Exploitation, and Dissemination
TREAS	Department of the Treasury
TSC	Theater Security Cooperation
TTF	Time to Failure
UAV	Unmanned Aerial Vehicle
UGV	Unmanned Ground Vehicle
UJTL	Universal Joint Task List
UMS	Unmanned Systems

UNCLOS	United Nations Covention on the Laws of the Sea
UOSV	Unmanned Outer Space Vehicle
USA	United States Army
USAF	United States Air Force
USMC	United States Marine Corps
USN	United States Navy
USCG	United States Coast Guard
USD (I)	Undersecretary of Defense for Intelligence
USSOCCOM	United States Special Operations Command
USSV	Unmanned Sea Surface Vehicle
USV	Unmanned Surface Vehicle
UUV	Unmanned Underwater Vehicle
UV	Unmanned Vehicle
UXO	Unexploded Explosive Ordnance
UWB	Ultra Wide Band
VPOTUS	Vice President of the United States
VTC	Video Tele-Conference
WBS	Work Breakdown Structure
WMD	Weapons of Mass Destruction
WWI	World War 1
WWII	World War 2

7.3. ABBREVIATIONS

CDR	Commander
COL	Colonel
CPT	Captain
MAJ	Major
ME4	Engineer (Singaporean Military Rank)
ME5	Senior Engineer (Singaporean Military Rank)
LT	Lieutenant
LTC	Lieutenant Colonel
LTJG	Lieutenant Junior Grade
RADM	Rear Admiral
USA	United States of America

THIS PAGE INTENTIONALLY LEFT BLANK

8.0. LIST OF REFERENCES

1. Blanchard, Benjamin S. and Wolter, J Fabrycky, *Systems Engineering and Analysis*, 4th Edition, Pearson Prentice Hall, Upper Saddle River, NJ, 2006.
2. U.S. Department of Defense, Joint Publication 3-30. *Command and Control for Joint Air Operations*. 12 January 2010.
3. U.S. Department of Defense, *FY2009-2034 Unmanned Systems Integrated Roadmap*, Pentagon, Washington, DC, April 2009.
4. Huang, Hui-Min, “Autonomy Levels for Unmanned Systems (ALFUS) Framework, Volume I: Terminology”, Intelligent System Division, National Institute of Standards and Technology, Sept 2004.
5. Inagaki, T. Human-Machine Collaboration for Safety and Comfort. Presented to ENRI International Workshop on ATM/CNS. 2009. p. 1.
6. Buede, Dennis, M, *The Engineering Design of Systems* New York: John Wiley & Sons, Inc., 2000.
7. U.S. Department of Defense. MIL-HDBK-46855A (Human Engineering Program Processes and Procedures). 17 May 1999.
8. Price, H. E. The Allocation of Functions in Systems. *Human Factors*. Vol 27, No. 1.1985.
9. Malasky, Jeremy S. Human Machine Collaborative Decision Making in a Complex Optimization System. 12 May 2005.
10. Elizabeth Haubert Joseph , Joseph Tucek , Larry Brumbaugh , William Yurcik, “Tamper-Resistant Storage Techniques for Multimedia Systems,” In *IS&T/SPIE International Symposium Electronic Imaging / Storage and Retrieval Methods and Applications for Multimedia*. 2005.
11. U.S. Department of Defense, Joint Publication 1-02, *DOD Dictionary of Military and Associated Terms*, October 2009.

THIS PAGE INTENTIONALLY LEFT BLANK

APPENDIX A NAVAL EXPEDITIONARY COMBAT COMMAND (NECC) RESEARCH

A.1. OVERVIEW OF NECC

A.1.1. Mission Overview

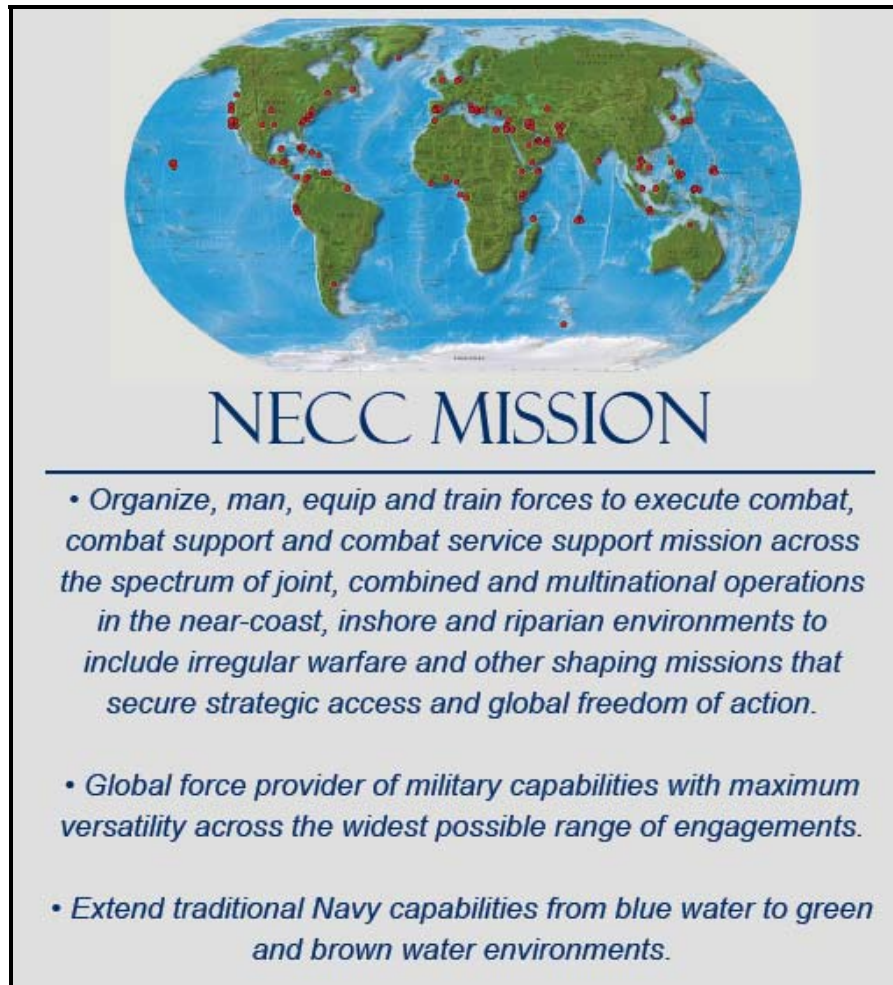

Figure 83. NECC Mission¹²²

¹²² NECC Force Capabilities Fact Sheet. Navy Expeditionary Combat Command. Accessed 20May2010.

A.1.2. Force Capabilities

There are ten primary force capabilities which are managed by NECC:

- Riverine
- Naval Construction (Seabees)
- Explosive Ordnance Disposal (EOD)
- Maritime Expeditionary Security Force (MESF)
- Expeditionary Intelligence
- Expeditionary Logistics
- Maritime Civil Affairs
- Security Force Assistance
- Combat Camera
- Expeditionary Combat Readiness

A.2. SCOPING FORCE CAPABILITIES FOR ANALYSIS

The SEA-16 tasking statement originally proposed that the project focus the development of a joint systems concept and supporting architecture to integrate unmanned vehicles in the Navy fleet structure, using the NECC Mission Statement shown in [Figure 83](#), and focused on NECC missions.¹²³ Initial research made it apparent that the project would have to be scoped to a limited number of the force capabilities.

NECC representatives discussed some initial needs in a video tele-conference (VTC) on 06 November 2009. Mr. Jim Fowler and CDR Glenn Allen of NECC met with the SEA-16 cohort, Professor Gary Langford (Thesis Advisor), RADM (ret) Rick Williams, and CAPT (ret) Chuck Calvano to identify the preliminary areas of focus and state their organizational needs with regards to these capability areas, as shown in [Figure 84](#). Explosive Ordnance Disposal (EOD), Riverine Forces, and Maritime Expeditionary

¹²³ SEA-16 CAPSTONE PROJECT OBJECTIVES, 03 September 2009

were chosen to be those areas of study. These three areas were assessed to benefit the most from the successful implementation of UMS in the near term. Each area was assigned to an Integrated Project Team for research and assessment. The products of each of these areas are presented in Section A.3.

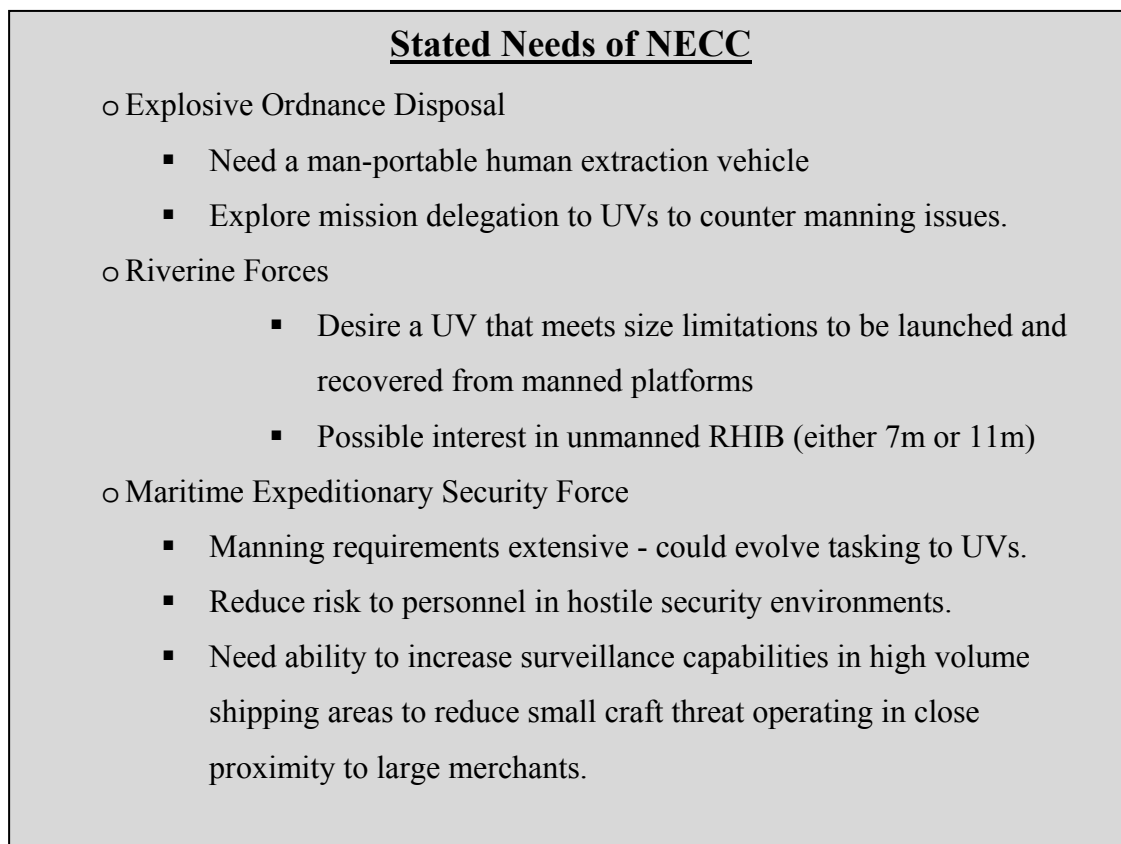

Figure 84. Stated Needs of NECC

A.3. CONTEMPORARY ANALYSIS OF SELECTED NECC CAPABILITIES

A.3.1. Riverine Force Analysis

A.3.1.1. Organization

- Riverine Group One
- Riverine Squadron 1 (RIVRON 1 >100 sailors) Deployed in Iraq from Apr – Oct 07

- Riverine Squadron 2 (RIVRON 2 >130 sailors) Deployed in Iraq from Oct 07 – Apr 08
- Riverine Squadron 3 (RIVRON 3 >150 sailors) Deployed in Iraq from Apr 08 – Oct 08
- Each squadron commanded by O-5
- Each squadron is self sufficient
- Squadrons may act individually or in a joint environment or with coalition partners

A.3.1.2. Missions

- Conduct Maritime Security Operations
 - Establish control of rivers in specific regions for specific periods of time
 - Protect lines of communication
 - Deny the enemy commercial and military use of rivers
 - Establish an area of operations for power projection ashore
 - Protect naval logistic support to forward deployed forces
- Positively interact with local population to win public support
 - Patrol and Interdiction
 - Protect friendly lines of communication
 - Deny hostile forces the use of waterways
 - Collect intelligence information
 - Perform security missions
 - Enforce population and resources control

- Locate and destroy hostile forces, bases, and supplies within riparian area
- Anti-Piracy
 - Employ Riverine craft to deny resources to an enemy and prevent piracy of pure criminal intent
 - Persistent presence to deter piracy
- Law Enforcement
 - Boarding teams to board and search indigenous watercraft
 - Enforce population and resource control measures
 - Collect intelligence information
 - Protect critical infrastructure

A.3.1.3. *Operations*

- Riverine area control
 - Protect critical infrastructure along river
 - Provide secure area to conduct military operations
 - Support civil affairs efforts along or nearby river
- Interdiction of river lines of communication
 - Impede, disrupt, eliminate enemy personnel and supply movement on rivers
- Fire support
 - Provide fire support with crew service weapons
- Insertion and extraction of conventional land forces
 - Insert between platoon and company size unit
- Theater Security Cooperation

- Primary employment of Riverine forces during peacetime
- Garner trust and cooperation of coalition nations

A.3.1.4. *Operational Capabilities*

- Command and Control
- High Speed and Mobility
- Firepower
- Fire support
- Intelligence and Surveillance
- Visit, Board, Search, and Seizure
- Insertion and Extraction of Conventional Ground Forces
- Self Defense
- Survivability
- Expeditionary Logistics and Sustainment
- Maintainability and Reliability in Expeditionary Environment
- Medical Treatment and Evacuation
- Rapidly Deployable
- Support to Psychological Operations and Civil Military Operations
- Information Operations Support
- Support to Other Military Operations
- Training of Partners and Coalition Forces
- Aviation Support
- UMS support

- Fire Support and Forward Observers

A.3.1.5. *Operational Limitations*

- Small units that cannot sustain during high intensity missions
- Can only gain local control of river where actively patrolling
- Limited fire power (need fire support)
- Cannot conduct direct combat against a large organized armed force
- Situational awareness (need ISR support)

A.3.1.6. *Environment*

- Rivers, Deltas, Harbors, Reservoirs, Lakes
- Riverine Classifications
 - Type I: One or more major rivers with branches of numerous smaller streams, canals, paddies that present an obstacle, but are not LOCs
 - Type II: Several major waterways in addition to extensive network of small rivers, canals, irrigation ditches that present an obstacle, but are LOCs.
 - Type III: Several major waterways in addition to extensive network of rivers, canals, irrigation ditches that do not present an obstacle and are LOCs.

A.3.1.7. *Threats*

- Expected to operate against up to a Level II threat
- Many threats exist, including:
 - Water based mines

- Attack swimmers
- Direct Fires
- Indirect Fires
- Suicide bombers and other terrorist activities
- Criminals

A.3.1.8. Utilization of UMS

- USVs and UUVs used to support force in close space to conduct search and surveillance
- UAVs provide persistent search and surveillance, communications relay, targeting
- UAVs extend and improve Maritime Domain Awareness in riparian environment
- Use drives up operational tempo of small force and reduces size of reaction force
- Riverine Tactical Operation Center utilizes UV images to increase situational awareness

A.3.2. Explosive Ordnance Disposal Analysis

A.3.2.1. Organization¹²⁴

- Groups - There are two EOD Groups: EODGRU ONE in San Diego, California (Naval Amphibious Base Coronado), and EODGRU TWO at Norfolk, Virginia (Naval Amphibious Base Little Creek).
- Mobile Units - Each Group has readiness responsibility for several subordinate EOD Mobile Units (EODMU). EODMUs are trained and proficient in the use of various small arms and unit tactics for the

¹²⁴ NECC “EOD Fact Sheet”
http://www.public.navy.mil/usff/necc/Documents/04_EOD_FactSheet.pdf

prosecution of their core mission skill sets in a combat environment and for seamless integration with Navy and Army Special Operations Forces, and Marine Corps Expeditionary Units.

- Company/Platoons and Detachments - EOD Mobile Units are responsible for several shore-based EOD Detachments supporting key naval installations. EODMUs have readiness responsibility for deployable Mine Countermeasures Platoons (EOD MCM Platoons), multi-mission Mobile Company/ Platoons (EOD MOB Company/Platoons), and Marine Mammal System Companies (MMS Companies).
- Mobile Diving and Salvage - EOD is also organized into ready units of specialized dive teams that conduct harbor and waterway clearance, emergent underwater repairs, and salvage operations in all environments In depths up to 300 feet.
- Training and Evaluation - Specialized units located on both coasts train all EOD forces, develop and evaluate EOD tools, tactics, and techniques in preparation to deploy.

Marine Expeditionary force is in direct operational control of NECC EOD assets. These assets fall below the regiment level of a Ground Division for both operations and support.

- MEF
 - Division (Ground)
 - Regiment
 - EOD Assets
 - Combat Service Support Group (CSSG)
 - Logistics Regiment
 - EOD Assets

EOD Assets are often two to four man teams. Up to two teams are assigned to a battalion and in each regiment there up to four battalions.

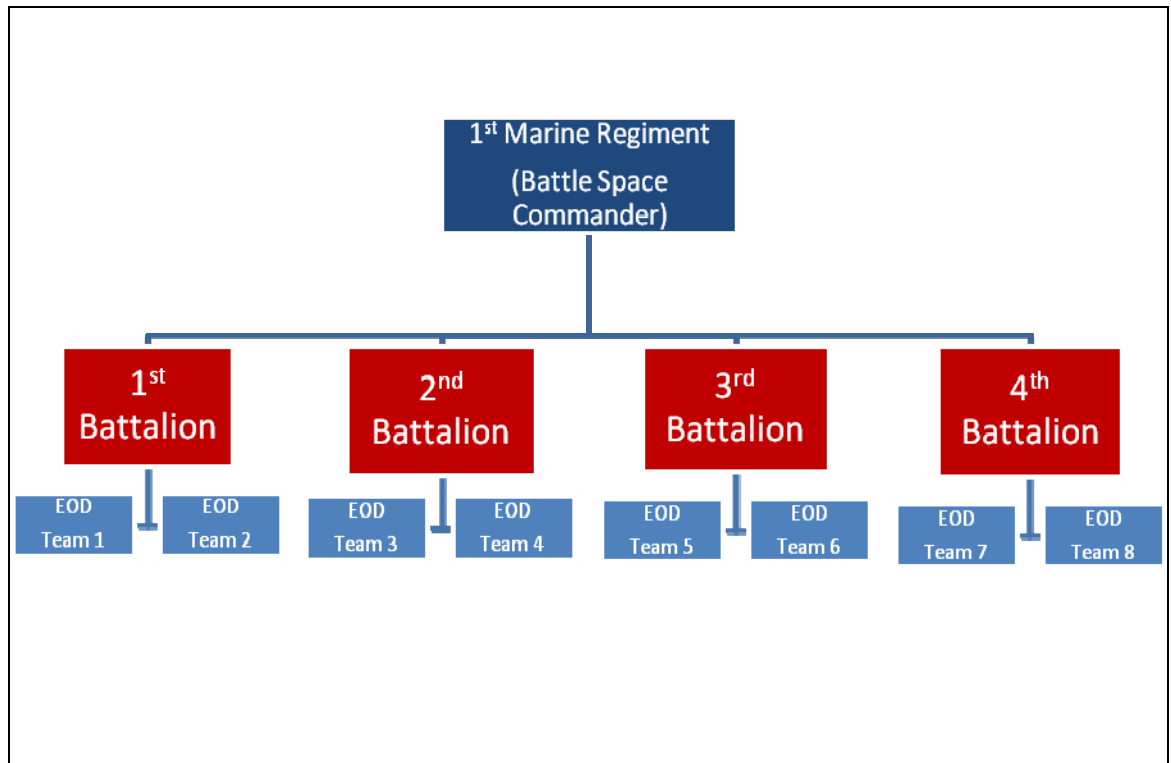

Figure 85. EOD Team Deployment

A.3.2.2. Mission¹²⁵

- EOD personnel are highly trained, skilled warriors who are experts in explosives, diving, parachuting, weapons, and small unit tactics
- Render safe all types of explosive hazards, including conventional ordnance, improvised explosive devices, and Weapons of Mass Destruction (chemical/biological, nuclear, and radiological weapons)
- Conduct clandestine operations either independently, or as part of a larger combatant force
- Support the most elite units of U.S. Special Operations Command (USSOCOM), to include direct action support of Navy SEALs

¹²⁵ NECC “EOD Fact Sheet”
http://www.public.navy.mil/usff/necc/Documents/04_EOD_FactSheet.pdf

and Army Special Forces

- Conduct demolition of hazardous munitions, pyrotechnics, and retrograde explosives using detonation and burning technique
- Support military and civilian law enforcement agencies by analyzing and handling foreign and domestic explosives
- Work with the U.S. Secret Service and the U.S. State Department, helping to protect the President of the United States (POTUS), Vice President (VPOTUS), as well as foreign officials and dignitaries
- Support the U.S. Department of Homeland Security, U.S. Customs Office, and the FBI as well as state and local authorities

A.3.2.3. Concept of Operations

In Figure 86 an example of when EOD is used. An infantry patrol visually detects an explosive device. Regional battlespace commander is then notified and they deploy an EOD team to interdict. EOD ensures the battlespace commander is apprised of the situation and this information is also passed on to Theatre Command Center.

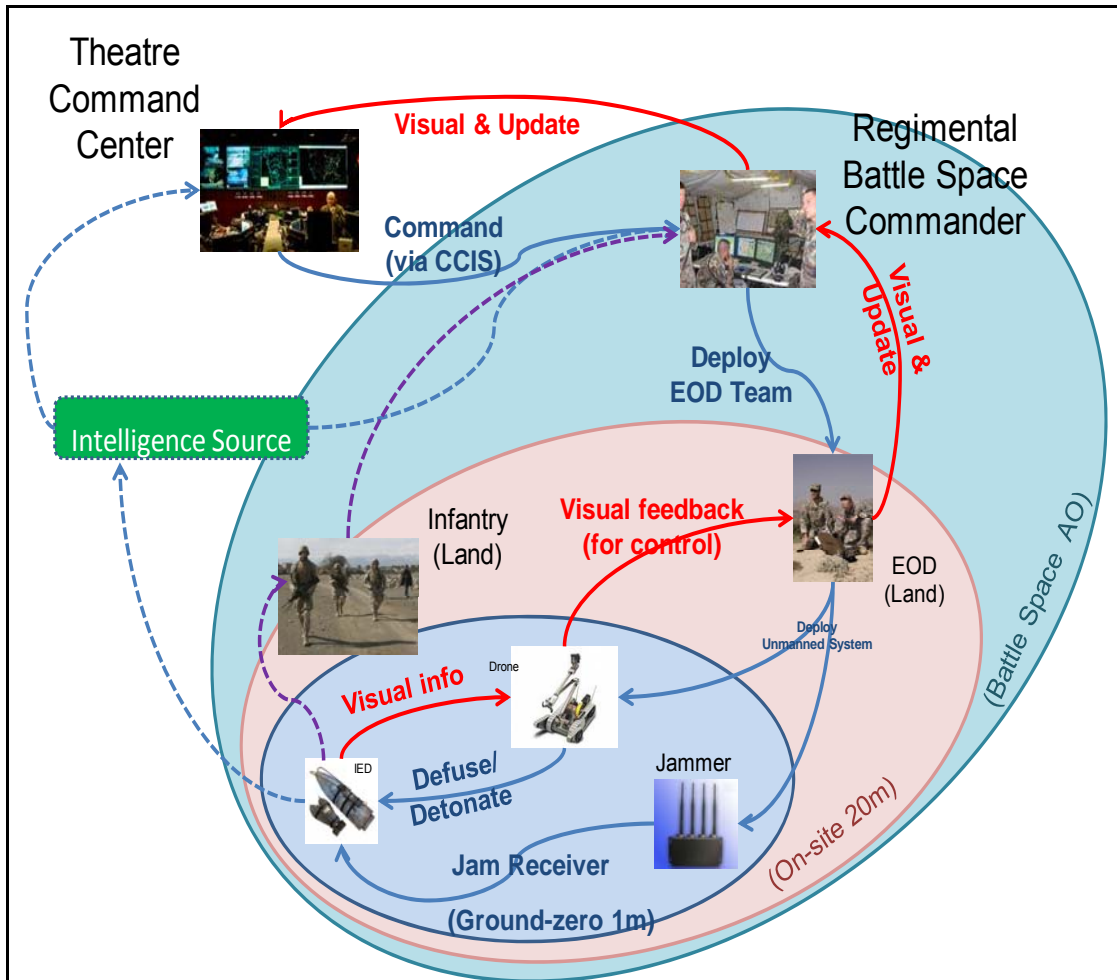

Figure 86. EOD Land CONOPS

A.3.2.4. Operational Limitations

- Rely on accurate intelligence to avoid unnecessary casualties.
- Can only gain local control of river where actively patrolling
- Need support personnel to protect them during operations
- Situational awareness (need ISR support)

A.3.2.5. *Environment*

- EOD personnel are trained to operate in all land and sea environments. They can be inserted by air, land or sea.

A.3.2.6. *Threats*

- Many threats exist, to EOD units beside the ordnance being disposed of the threats include:
 - Snipers
 - Proximity mines
 - Direct Fires
 - Indirect Fires
 - Suicide bombers and other terrorist activities
 - Incorrect assessment of ordnance disposal

A.3.2.7. *Utilization of UMS*

- UMS's are used to support to conduct search and disarmaments
- UMS's extend EOD's safety and longevity during missions
- EOD personnel also use UV images to increase situational awareness

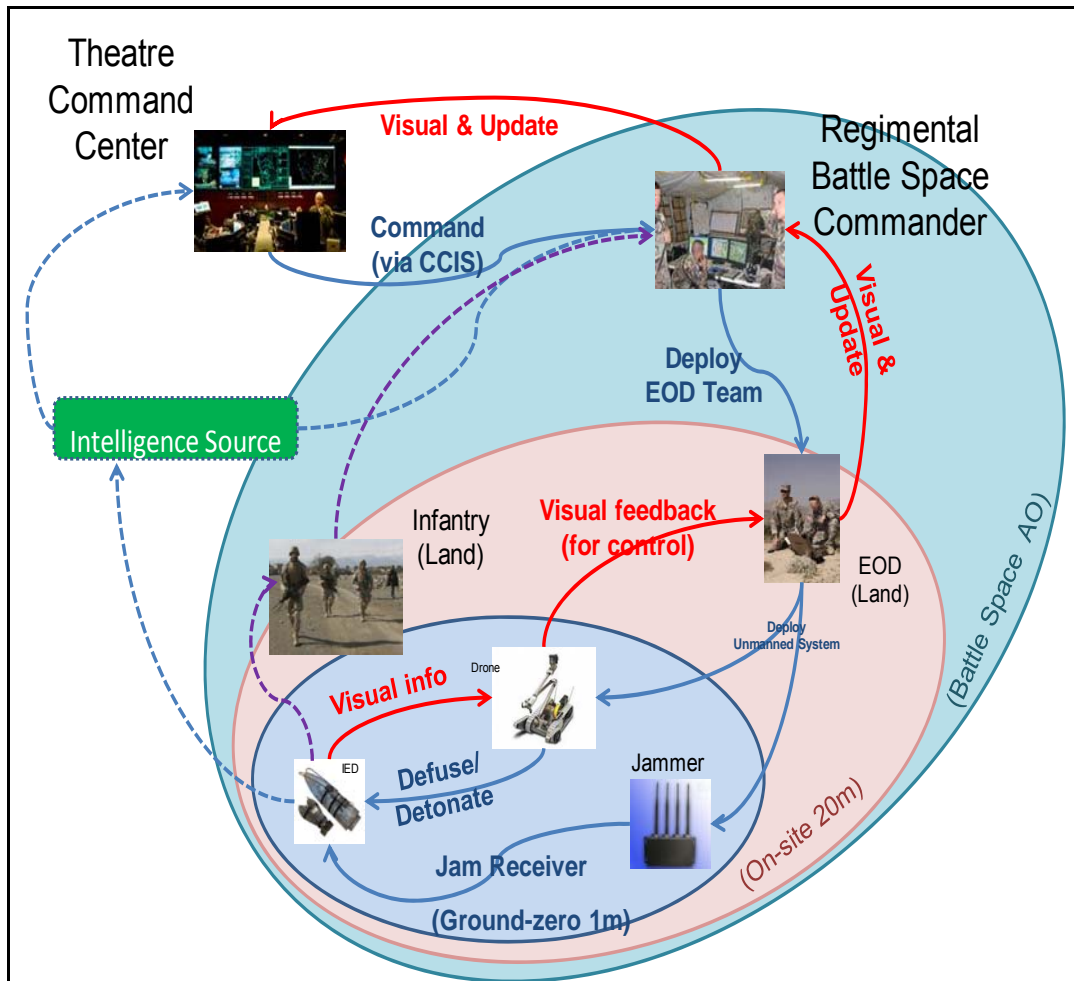

Figure 87. EOD Land CONOPS

A.3.3. Maritime Expeditionary Security Force Analysis

A.3.3.1. Organization

- Maritime Expeditionary Security Group (MESG)
 - 2 Active Groups
- Maritime Expeditionary Security Squadron (MSRON)
 - 1 Active Squadron
 - 5 Blended Active/Reserve Squadrons
 - 4 Reserve Component Squadrons
- Command and Control Divisions (C2DIV)

- 2 Active Component Units
- 7 Reserve Component Units
- Boat Divisions (BOATDIV)
 - 3 Active Component Units
 - 8 Reserve Component Units
 - 3 Blended Active/Reserve Units
- Security Divisions (SECDIV)
 - 6 Active Component Units 10 Reserve Component Units
- Helo, Visit, Board, Search and Seizure Detachments (HVBSSDET)
 - 2 Active Component Units

A.3.3.2. *Mission Decomposition*

“MESF’s primary mission is force protection. Anti-Terrorism Force Protection (ATFP) missions include harbor and homeland defense, coastal surveillance, and special missions. Units conduct force protection of strategic shipping and naval vessels operating in the inshore and coastal areas, anchorages and harbors, from bare beach to sophisticated port facilities. Specialized units work together with Maritime Expeditionary Security Squadron (MSRON) staffs providing intelligence and communications. MESF units deploy worldwide to detect, deter, and defend an area, unit, or High Value Asset.”¹²⁶

¹²⁶ MESF Fact Sheet. Navy Expeditionary Combat Command. Accessed 13 January 2010. http://www.necc.navy.mil/NECC%20Fact%20Sheets/00195_NECC_SubCom_MESF_FactSheet_2.pdf

This mission is functionally decomposed in [Figure 88.](#), with the high-level function of MESF as “Conduct Force Protection.”

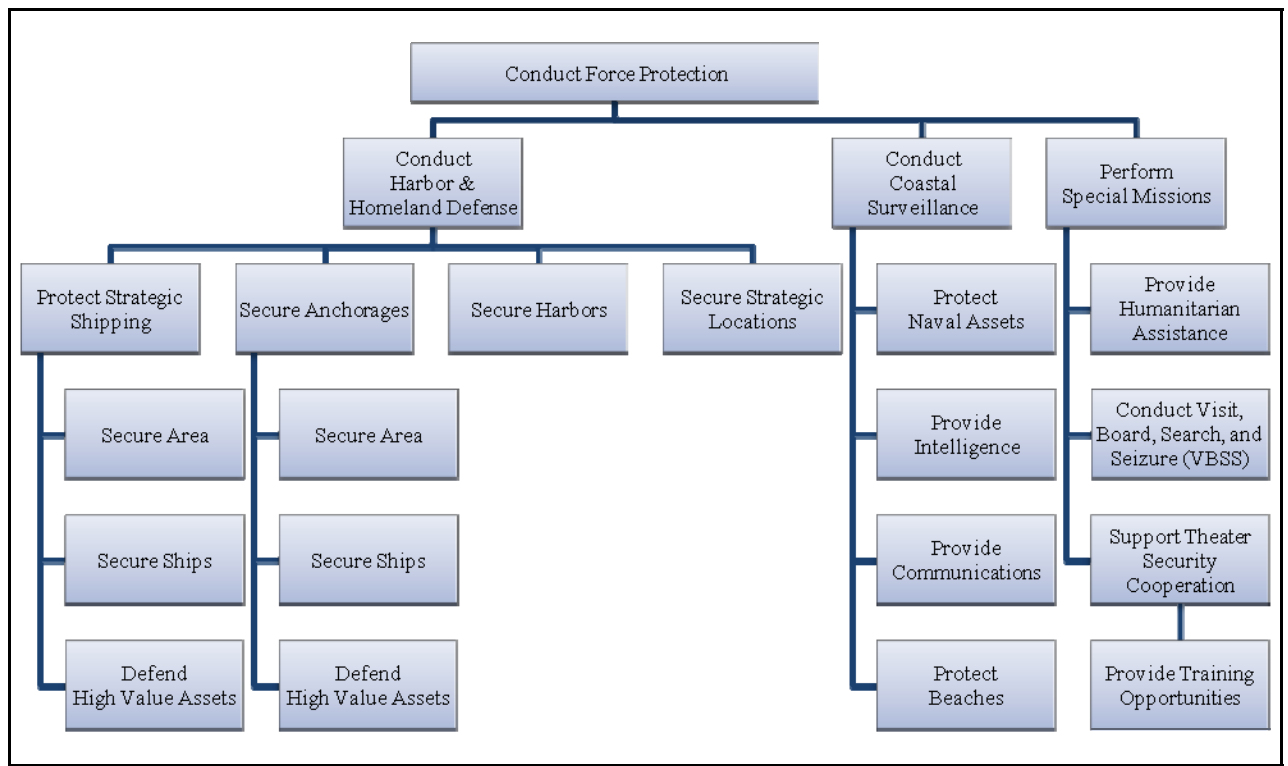

Figure 88. Functional Decomposition of MESF Missions

A.3.3.3. *Operations*

- Maritime Surveillance
- In-Shore Surveillance
- Security Operations
- Anti-Terrorism Force Protection
- Ground Defense
- Afloat Defense
- Airfield / Aircraft Security
- Detention Operations

- Law Enforcement

A.3.3.4. Roles

- Conducts scalable force protection and security for designated assets
- Provides layered defense in an integrated coastal and landward security environment
- Provides the NCC/JFMCC with adaptive force packages responsive to mission requirements
- Provides integrated maritime expeditionary security capabilities including:
 - Mobile and fixed defensive operations
 - Visit, Board, Search and Seizure (VBSS) Level III
 - Robust security in support of JFMCC operations across the spectrum of maritime engagement
- Supports Partner Nation Theater Security Cooperation (TSC) operations
- Provides training capability for partnering with other nations
- Supports Host Nation Security, Stabilization and Reconstruction Operations (SSTRO)
- Provides Maritime Interception Operations (MIO) Exploitation Teams
- Supports Maritime Expeditionary Intelligence Operations

A.3.3.5. Operational Limitations

- Small units that cannot sustain during high intensity missions
- Can only gain local control of river where actively patrolling

- Limited fire power (need fire support)
- Cannot conduct direct combat against a large organized armed force
- Situational awareness (need ISR support)

A.3.3.6. *Environment*

- Near Coast Area
 - Ground
 - Littoral Area

A.3.3.7. *Threats*

- Small Surface Crafts
 - Smugglers
 - Traffickers
 - Harassing State Actors
- Small Aircraft
 - Single engine Propeller
 - Unmanned drones
- Undersea and Submersibles
 - Smuggling submarines
 - Divers
 - Mines
 - Improvised Explosive Devices
- Electronic Warfare
 - Friendly Communication Exploitation

- Frequency management

A.4. POTENTIAL NECC APPLICATIONS TO 2030 JOINT UMS ARCHITECTURE

A.4.1. Riverine Force

Management of Assets

Manned / unmanned vehicle cooperation

Advance Scouts

Unmanned Patrols

Aerial or surface Fire Support

Obstacle detection and avoidance

Threat Assessment

A.4.2. Naval Construction (SEABEES)

Management of Assets

Unit Area Defense

Construction Assistance

A.4.3. Explosive Ordnance Disposal

Management of Assets

Identification of hazards

Unmanned removal of explosives

Personnel Recovery devices

Underwater Reconnaissance

Threat Assessment

A.4.4. Maritime Expeditionary Security Force

Management of Assets

Manned / unmanned vehicle cooperation

UV Swarm Capability and Countering

Unmanned Patrols

Aerial or surface Fire Support

Threat Assessment

A.4.5. Expeditionary Intelligence

Unmanned Surveillance

Cross-domain Threat Assessment

Timely information distributed through network

A.4.6. Expeditionary Logistics

Management of Assets

Identification of hazardous materials

Unmanned vehicle cargo handling

A.4.7. Maritime Civil Affairs

Management of Civil Operations

Unmanned Surveillance

Area Defensive Perimeter

A.4.8. Security Force Assistance

Network training for coalition partners

A.4.9. Combat Camera

Cross-domain Threat Information

Timely imaging from Unmanned Systems

Images quickly distributed through network

A.4.10. Expeditionary Combat Readiness

Management of Assets

Images quickly distributed through network

A.5. OPERATIONAL SCENARIOS

A.5.1. OPSIT 1: Oil Platform (OILPLAT) Protection

The situation is based on the current day usage of a Naval Expeditionary Combat Command (NECC) Maritime Expeditionary Security Force (MESF) securing an Oil Platform (OILPLAT) in the Arabian Gulf.

Assumption: Routine day

Initial set-up for the security forces are in place

Unmanned Systems (UMS) are on a rotating basis to ensure 24/7 coverage for the organic forces stationed on the OILPLAT.

Threat: Unknown incoming surface vessel on an intercept course to the OILPLAT.

Resources: USVs

UAVs

Manned MESF RHIB

MESF Sentries on the OILPLAT

Background Info:

Initial Set-up is complete (assume normal day of operation)
Combat Information Center (CIC) centrally located
Perimeter establish IAW ROE to secure Oil Platform
UAVs and USV Hand off complete for on coming and off going
Off going proceed to maintenance, fuel, armament area. Can be used in the event of emergency

Phases of Mission: In addition to the following list the breakdown is shown in [Figure 89.](#), [Figure 90.](#), [Figure 91.](#), and [Figure 92.](#)

Surveillance Phase

1. UAV establishes link with Combat Information Center (CIC) upon entry into battlespace
2. CIC uploads mission tasking to UAV
3. UAV confirms mission tasking with CIC
4. UAV patrols region and provides real-time surveillance around OILPLAT
5. USV establishes link with CIC
6. CIC uploads mission tasking to USV
7. USV confirms mission tasking with CIC
8. USV patrols region and provides real-time surveillance around OILPLAT to CIC

Detect Phase

9. UAV transmits unknown surface contact data to CIC
10. CIC initiates increased posture to MESF
11. CIC initiates increased posture to USV
12. CIC relays threat to MESF
13. CIC relays threat to USV
14. CIC alters mission tasking and maneuvers USV to intercept target vessel
15. CIC transmits threat information to network

Track Phase

16. CIC alters USV tasking to monitor threat
17. UAV tracks targets and transmits updated video and data to CIC

Engage Phase

18. CIC transmits warning via USV onboard communication gear to the target craft.
19. CIC transmits updated threat information to network
20. CIC authorizes USV to engage hostiles with onboard weapons
21. CIC authorizes MESF to engage hostiles
22. MESF transmits Battle Damage Assessment (BDA) data to CIC
23. USV transmits BDA data to CIC
24. UAV transmits BDA data to CIC
25. CIC transmits downgraded protective posture to UAV
26. CIC transmits downgraded protective posture to MESF
27. CIC transmits downgraded protective posture to USV
28. CIC transfers UAV to surveillance mode
29. CIC transfers USV to surveillance mode
30. MESF restored to stand-by posture by CIC
31. CIC transmits downgraded posture to the network

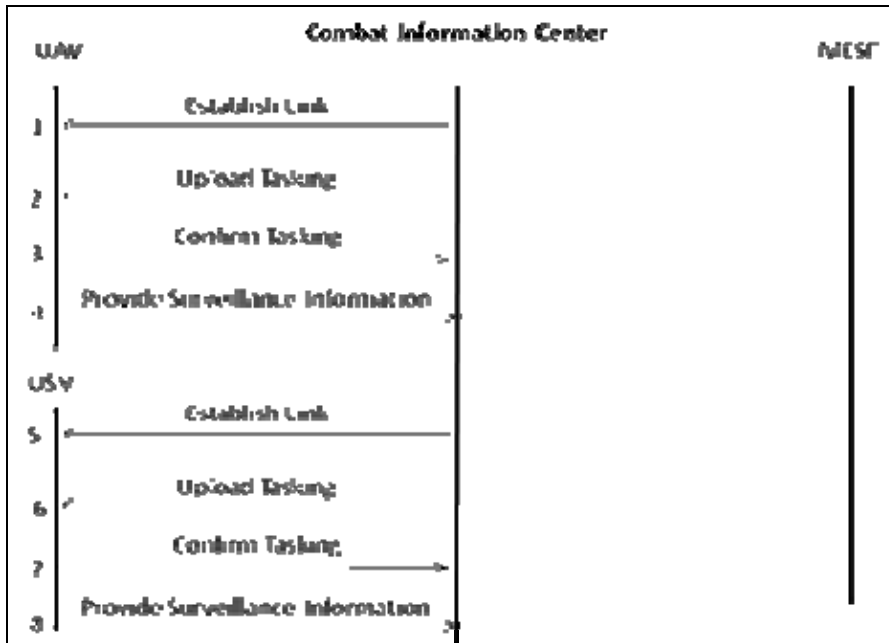

Figure 89. OILPLAT Input/Output Trace Diagram 1

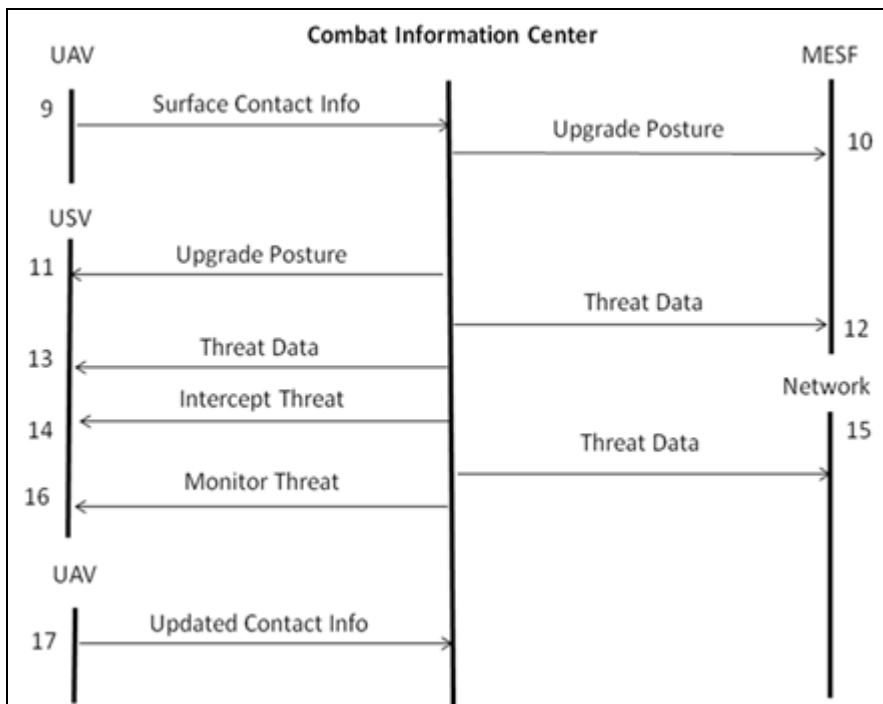

Figure 90. OILPLAT Input/Output Trace Diagram 2

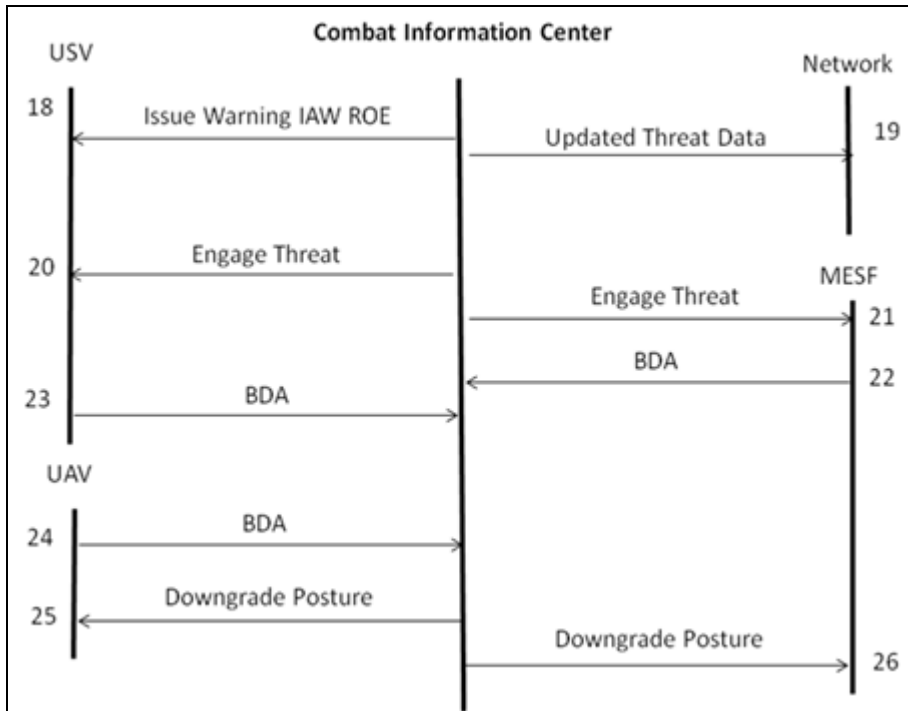

Figure 91. OILPLAT Input/Output Trace Diagram 3

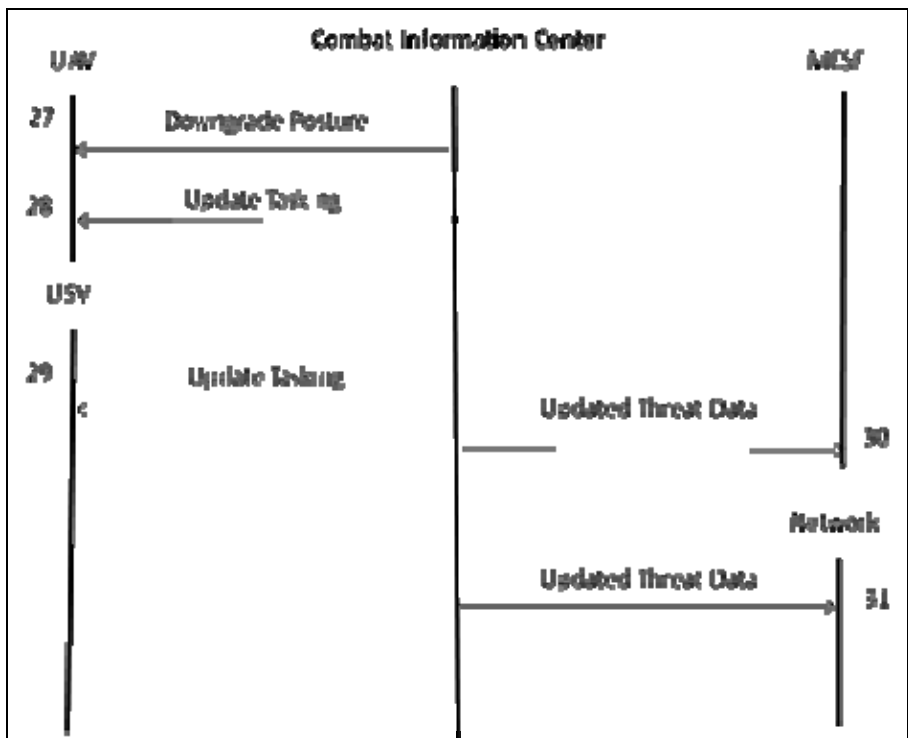

Figure 92. OILPLAT Input/Output Trace Diagram 4

A.5.2. OPSIT 2: RIVERINE PATROL

The situation is based on the current day usage of a Naval Expeditionary Combat Command (NECC) Riverine Force performing a routine patrol in support of waterborne security.

Assumption: Routine day

Initial set-up for the security forces are in place

Unmanned Systems (UMS) are on a rotating basis to ensure 24/7 coverage for the organic forces.

Patrol initiates from a secure US controlled area

Threat: Ambush from insurgents using watercraft

Ambush from insurgents from positions overlooking the river

Resources: USVs

UAVs

Manned Riverine RHIB

Background Info:

Initial Set-up is complete (assume normal day of operation)

Combat Information Center centrally located

Perimeter establish IAW ROE to protect Riverine Patrol

Phases of Mission: In addition to the following list the breakdown is shown in [Figure 93.](#), [Figure 94.](#), and [Figure 95.](#)

Launch Phase

1. Riverine RHIB requests surveillance of patrol area
2. Launch Riverine RHIBs
3. UAV establishes link with Combat Information Center (CIC) upon entry into battlespace

4. CIC uploads mission tasking to UAV
5. UAV confirms mission tasking with CIC
6. UAV patrols region and provides real-time surveillance around Riverine Patrol Area to CIC
7. USV establishes link with CIC upon entry into battlespace after turnover.
8. CIC uploads mission tasking to USV
9. USV confirms mission tasking with CIC
10. USV patrols region and provides real-time surveillance around Riverine Patrol Area to CIC

Detect Phase

11. UAV transmits data of potential threat to CIC
12. CIC initiates increased posture to UAV
13. CIC initiates increased posture to USV
14. CIC initiates increased posture to Riverine Patrol
15. CIC relays threat to Riverine Patrol
16. CIC relays updated threat information to network

Track Phase

17. CIC alters USV tasking to monitor threat
18. USV tracks targets and transmits updated video and data to CIC
19. UAV tracks targets and transmits updated video and data to CIC

Engage Phase

20. CIC authorizes USV to engage hostiles with onboard weapons
21. CIC authorizes Riverine Patrol to engage hostiles
22. Riverine Patrol transmits Battle Damage Assessment (BDA) data to CIC
23. USV transmits BDA data to CIC
24. UAV transmits BDA data to CIC
25. CIC transmits downgraded protective posture to UAV
26. CIC transmits downgraded protective posture to USV
27. CIC transmits downgraded protective posture to Riverine Patrol

28. CIC authorizes Riverine Patrol return to base for re-supply and re-deployment

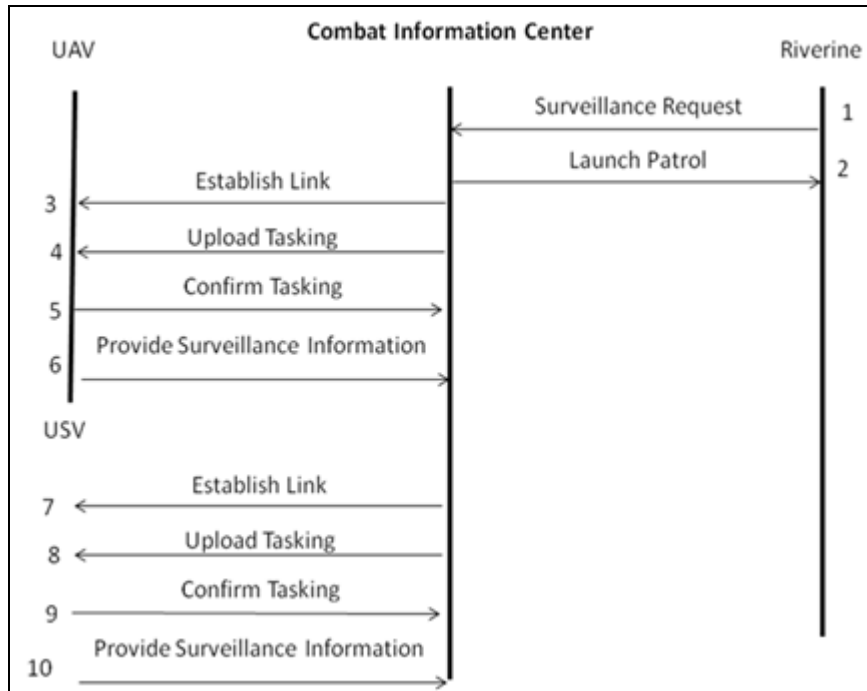

Figure 93. RIVERINE Input/Output Trace Diagram 1

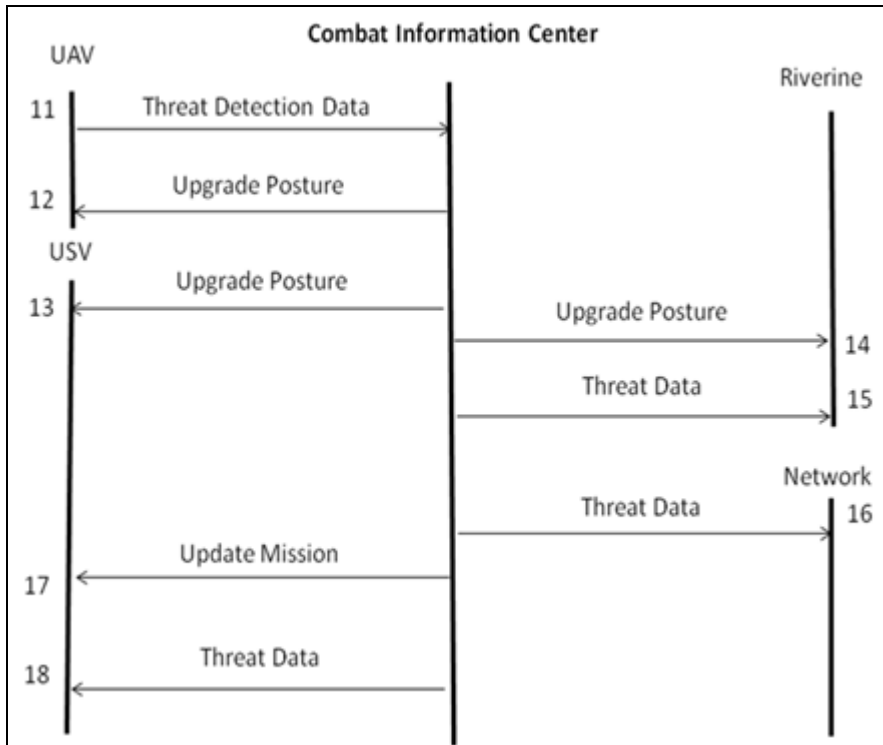

Figure 94. RIVERINE Input/Output Trace Diagram 2

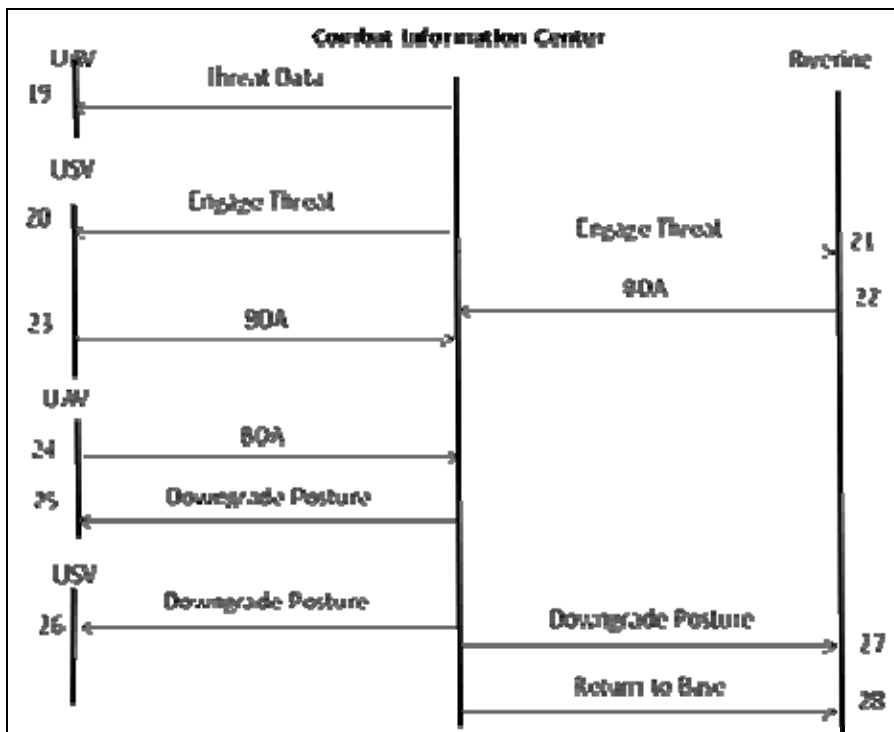

Figure 95. RIVERINE Input/Output Trace Diagram 3

THIS PAGE INTENTIONALLY LEFT BLANK

APPENDIX B UNMANNED SYSTEMS RESEARCH

Appendix B is a compilation of Unmanned Systems (UMS) that are either in use in the field, in testing, in the research and development phase, or future concepts or systems.

Appendix B was used to assist in the development of the model and simulations in the project to assess the viability of the concept. While the project used only open sources data on the Predator UAV, the model is functional enough that obtained data for many UMS could be used to run the model and test it for usefulness. The Predator data was used as the baseline and reasonable extrapolations for future systems of a “Predator-like” UAV for future use.

Appendix B are broken up into the six sections. The first section is a history of UMS, and the following five section are divided into the categories previously described in the paper; UAV, USV, UUV, UGV, and UOSV.

B.1. HISTORICAL MILITARY USAGE OF UMS

UMS are not a new development and can be traced back almost a century. In World War I, the Imperial German Navy used FL-boats (Fernlenkboote) which were wired guided from shore and assisted by manned spotter aircraft to attack and destroy coastal shipping.¹²⁷

In the Winter War against Finland and in the early stages of World War II the Soviet Red Army employed remotely controlled teletanks. While only capable of less than a mile of distance for control, they were still able to take the “man” out of the immediate battlefield. The Red Army also employed remote controlled cutters and experimented with aircraft.¹²⁸

¹²⁷ Imperial Germany UMS, available from <http://www.absoluteastronomy.com/>, accessed January 20, 2010.

¹²⁸ Soviet Red Army UMS, available from <http://www.absoluteastronomy.com/>, accessed January 20, 2010.

Similar to the Germans and Soviets, the US also experimented with unmanned vehicles in the early years of the 20th Century. Prior to WWI the US Navy developed a sea plane that was capable of unmanned flight. In WWII the Navy also used plywood UAV for attacking heavily defended targets.¹²⁹

Project Aphrodite was an Army Air Corps that used older B-17 Flying Fortress flown to altitude by a pilot, who would then eject. The the B-17 would be piloted remotely from a second B-17 and crashed into the intended target to limit losses of aircraft and crews over difficult targets. Another aspect of this was the use of drone B-17's during the atomic tests in the South Pacific. Another Army project involved the development of a reconnaissance UAV from a drone. Initially fitted with cameras they were later modified with television systems.¹³⁰

By 1964, an Air Force drone reconnaissance program, known as Buffalo Hunter, was under full development. A C-1 30D aircraft could carry up to four drones under its wings, flying out of Vietnam they would launch them like missiles on a preprogrammed flight over enemy held territory. From the mid-1960s until the end of the Vietnam War, more than 3,000 missions were flown over North Vietnam and China.¹³¹

Another Vietnam ear UAV program run by the Navy involved helicopters equipped with television cameras and torpedoes, to attack supply barges in the Mekong Delta. This program had limited success, mainly because of limited capability caused by the technology immaturity of the flight gyroscopes of the times.¹³²

Following Vietnam, it was noted that Remotely Piloted Vehicles (RPV) had the potential for added value in the modern battlefield and force structure. A group called the National Association of Remotely Piloted Vehicles (NARPY) was established. Over several decades, research and development in UMS grew globally, and that group evolved to include the international community. Now, this group is known as the

¹²⁹ UAV Introduction, available from <http://www.globalsecurity.org/>, accessed January 20, 2010.

¹³⁰ Ibid.

¹³¹ Ibid.

¹³² Ibid,

Association for Unmanned Vehicle Systems International (AUVSI). “AUVSI continues as the hub of the global unmanned systems community. Through communication, education, advocacy, awareness and leadership, the organization continues to promote and support unmanned systems.”¹³³

Operations Desert Storm and Iraqi Freedom both used UAV to provide intelligence gathering and fire support. Operations in Afghanistan have also used UMS to detect IEDs and attack targets of opportunity and kill key personnel in the Taliban and Al Qaeda organizations.

In addition to the United States many other countries are working to develop and integrate UMS into their force structures. Use of UMS can help commanders make better and timelier decisions along with the potential of keeping personnel safer. Using UMS for dangerous missions such as surveillance and IED detection can help to limit injury and death to our highly trained personnel. Conceptually, UMS are not a new way of doing business, what is new is the equipment and technology that are going into modern UMS.

B.2. UNMANNED AERIAL VEHICLES

B.2.1. Current Unmanned Aerial Vehicles

B.2.1.1. MQ-1 Predator (General Atomics Aeronautical Systems)

One of the most widely known UAV is the General Atomics MQ-1 Predator UAV. The first Predators were used for surveillance but over the years and an exponential increase in usage the latest version are also armed with Hellfire missiles. They are used by not only the US military but also government agencies like the CIA for surveillance and precision attacks in Iraq and Afghanistan.¹³⁴

¹³³ AUVSI, available from <http://www.auvsi.org/>, accessed January 20, 2010.

¹³⁴ MQ-1 Predator, available from <http://www.ga.com/index.php>, accessed January 10, 2010.



Figure 96. General Atomics MQ-1 Predator UAV.¹³⁵

Habitat: The skies of Afghanistan, Pakistan and Iraq.

Behavior: Predator, as shown in [Figure 96.](#), is one of only two major U.S. unmanned systems that carry weapons (in this case, two Hellfire air-to-ground missiles), the Predator bears the brunt of the hunter-killer role with its successor, the beefier MQ-9 Reaper. It has a range of 400 nautical miles, and an endurance of 40 hours.¹³⁶

Notable Features: The Predator was first drone system to see heavy use both as a reconnaissance platform and in an attack role, first seeing action in Bosnia in the mid 1990s. The name "Predator" is now almost synonymous with hunter-killer UAVs. Configured with a satellite data link system, Predator is equipped with an EO/IR stabilized gimbal containing two color video cameras and a forward-looking infrared (FLIR) camera as well as a synthetic aperture radar (SAR). The Predator has been configured with air-to-air or air-to-ground weapons as well as a laser designator. Since 1995, Predator has logged over 405,000 flight hours, of which over more than half have been during combat area deployments to the Balkans, Southwest Asia, and the Middle East where Predator operates in support of U.S. and NATO forces. Based upon the

¹³⁵ MQ-1 Predator, available from <http://www.ga.com/index.php>, accessed January 10, 2010.

¹³⁶ Popular Science Magazine The Complete UAV Field Guide
<http://www.popsoci.com/technology/gallery/2010-02/gallery-future-drones>

success of the program, the U.S. Department of Defense transitioned the Predator program to full rate production in August 1997, marking it as the first Advanced Concept Technology Demonstration (ACTD) program to be designated an Acquisition Category II Program.

Predators are currently in production for the U.S. and Italian Air Force. Land-based Predators have demonstrated the ability to support maritime forces including carrier battle groups, amphibious ready groups, and submarines. Predator is the only reconnaissance system available in the U.S. inventory that can provide near real-time video imagery day or night in all weather conditions via satellite worldwide - without exposing pilots to combat fire. As the first successful unmanned aircraft surveillance program, Predator provides tactical and strategic intelligence to operational commanders worldwide.¹³⁷

Features:

- Solid-state digital avionics
- Remotely piloted or fully autonomous
- SAR and EO/IR providing day/night and all-weather operations in one-mission aircraft
- GPS and INS
- UHF/VHF voice
- Extensive combat experience

Capabilities:

- Expanded EO/IR payload
- SAR all-weather capability
- Satellite control
- GPS and INS
- Endurance of 40 hours and a range 400 nmi
- Deployed with the U.S. and Italian Air Force

¹³⁷ General Atomics Aeronautical “Predator” <http://www.ga-asi.com/products/aircraft/predator.php>

- Operations to 25,000 ft (7620m)
- 450 lb (204 kg) payload
- Wingspan 48.7 ft (14.84m), length 27 ft (8.23m)

B.2.1.2. MQ-9 Reaper (General Atomics Aeronautical Systems)



Figure 97. General Atomics Reaper MQ-9 UAV¹³⁸

Habitat: Hunting and killing insurgents in Iraq, Afghanistan, and Pakistan. Patrolling the U.S. Mexican Border out of Fort Huachuca, Arizona.

Behavior: Reaper, as shown in [Figure 97.](#), has a wingspan of 66 feet, it's twice the size of its precursor MQ-1 Predator, and can loiter at 5,000 feet for up to 24 hours. Loaded with 3,000 pounds of munitions, including the GBU-12 laser-guided bomb and Hellfire tank-penetrating missiles, military commanders say it has become one of their most effective weapons in the current wars.¹³⁹

¹³⁸ General Atomics Reaper MQ-9 UAV, <http://www.afrc.af.mil/photos/mediagallery.asp?galleryID=332>, accessed May 15, 2010.

¹³⁹ Popular Science Magazine The Complete UAV Field Guide <http://www.popsci.com/technology/gallery/2010-02/gallery-future-drones>, accessed May 15, 2010.

Notable Feature: After being launched by operators using radio-control equipment, it's flown via satellite link from pilots on safe soil in the U.S.

B.2.1.3. ScanEagle (Insitu/Boeing)

Another system that is gaining ground in the US Navy is ScanEagle. Compact and lightweight ScanEagle can be operated from even the smallest naval ships; including the Mark V naval special warfare craft or flight deck of any surface ship with its catapult launching system and a patented “Skyhook” retrieval system. ScanEagle is strictly a surveillance platform with either a stabilized electro-optical or infrared cameras for day and night surveillance. The latest version being tested is capable of 22hours of flight time.¹⁴⁰



Figure 98. Insitu/Boeing ScanEagle.¹⁴¹

¹⁴⁰ ScanEagle, available from <http://www.boeing.com/>, accessed January 10, 2010.

¹⁴¹ Ibid.



Figure 99. Insitu/Boeing ScanEagle.¹⁴²

Habitat: With Marine Corps troops in Iraq or aboard U.S. Navy ships anywhere in the world.

Behavior: ScanEagle, as shown in [Figure 98](#) and [Figure 99](#), weighs 40 pounds and is four-feet long with a 10.2-foot wingspan. Powered by a gasoline engine for 15 hours. Its catapult launch makes it ideal for tight spaces, like the deck of the ship that rescued Capt. Richard Phillips from Somali pirates last in April 2010.¹⁴³

Notable Feature: To land, the ScanEagle's navigation points it toward a sky-hook that snares it out of the sky. Developed in partnership with The Boeing Company, ScanEagle is highly stealth at very low altitudes enabled by a low acoustic, visual, and infrared range signature, an advanced muffler, and a mature modular design that enables carriage of electro-optic or infrared imaging payloads.¹⁴⁴

¹⁴² Ibid.

¹⁴³ Popular Science Magazine The Complete UAV Field Guide <http://www.popsci.com/technology/gallery/2010-02/gallery-future-drones>, accessed May 15, 2010.

¹⁴⁴ INSITU "Scan Eagle" <http://www.insitu.com/scaneagle>, accessed January 20, 2010.

B.2.1.4. RQ-11B Raven



Figure 100. RQ-11B Raven¹⁴⁵

Habitat: The Raven, as shown in [Figure 100](#), is the most prevalent UAV on the planet, with more than 7,000 units in service. The RQ-11B is currently being used in Iraq and Afghanistan by army brigades.

Behavior: The RQ-11B not only provide situational awareness it also provide target information for Air Force Special Operations Command Battlefield Airmen and Air Force security forces. The Raven falls into the class of Air Force small UAS known as man-portable UAS.¹⁴⁶

¹⁴⁵ Air Force Official Site “RQ-11B Raven”
<http://www.af.mil/information/factsheets/factsheet.asp?id=10446>, accessed May 15, 2010.

¹⁴⁶ Ibid.

Spec: The Raven is typically fitted with an electronically stabilized color video camera or an infrared video camera for night missions, which pan, tilt and zoom digitally to provide ground troops with “situational awareness.” The fleet is expecting a digital upgrade that turns the Raven into a communications relay, effectively extending its six-mile range.

Features: The Raven back-packable system which features two air vehicles or AVs, a ground control unit, remote video terminal, transit cases and support equipment. Two specially trained Airmen operate the Raven AV. The AV can be controlled manually or can autonomously navigate a preplanned route.¹⁴⁷

Notable Feature: Light and durable design allows for easy replacement of wings upon a crash. The Raven also includes a color electro-optical camera and an infrared camera for night operations. The air vehicle is hand-launched.

General Characteristics²

Primary Function: Reconnaissance and surveillance with low altitude operation

Contractor: Aerovironment, Inc.

Power Plant: Electric Motor, rechargeable lithium ion batteries

Wingspan: 4.5 feet (1.37 meters)

Weight: 4.2 lbs (1.9 kilograms)

Weight (ground control unit): 17 lbs (7.7 kilograms)

Speed: 30-60 mph (26-52 knots)

Range: 8-12 km (4.9-7.45 miles)

Endurance: 60-90 minutes

Altitude (operations): 100-500 feet air ground level (to 152 meters)

¹⁴⁷ Ibid.

System Cost: approximately \$173,000 (2004 dollars)

Payload: High resolution, day/night camera and thermal imager

Date deployed: 2004

Inventory: 7000+

B.2.1.5. Wasp III (AeroVironment)



Figure 101. AeroVironment Wasp III.¹⁴⁸

Habitat: Deploys with U.S. Air Force Special Ops forces.

Behavior: The Wasp III, as shown in [Figure 101.](#), weighs one pound and is launched by hand this flying wing is outfitted with a day and night camera and can be programmed to fly an autonomous mission between takeoff and recovery. It flies 20 to 40 mph up to 500 feet, and is meant to be expendable once it gets its eyes on a target.¹⁴⁹

¹⁴⁸ Wasp III (BATMAV) Micro UAV, <http://defense-update.com/products/w/wasp3.htm>, accessed May 15, 2010.

¹⁴⁹ Popular Science Magazine The Complete UAV Field Guide <http://www.popsci.com/technology/gallery/2010-02/gallery-future-drones>, accessed May 15, 2010.

Notable Feature: Electrically powered, two-bladed propeller makes it very quiet. Its inventory is classified. This UAV was developed under a DARPA Micro-UAV program. Wasp III is equipped with forward and side looking color video cameras, as well as a modular forward or side looking electro-optical infrared payload. To maintain continuous coverage of a specific target, the Wasp automatically circles around it, maintaining the designated target in the side camera's field of view. The system is packed in a small suitcase, rapidly assembled within few minutes and is launched by hand toss.¹⁵⁰

B.2.1.6. Desert Hawk (Lockheed Martin)



Figure 102. Lockheed Martin Desert Hawk.¹⁵¹

Habitat: Used by British and American troops in Afghanistan.

¹⁵⁰ Defense Update “Wasp III Micro UAV” <http://defense-update.com/products/w/wasp3.htm>, accessed May 15, 2010.

¹⁵¹ Lockheed Martin Desert Hawk., <http://www.armybase.us/2009/05/lockheed-martin-successfully-tests-signals-intelligence-capability-and-improved-wing-design-on-desert-hawk-iii-unmanned-aircraft-system/>, accessed May 15, 2010.

Behavior: After manned launch the Desert Hawk, as shown in [Figure 102](#), follows pre-programmed coordinates to give troops an “over-the-hill” view, day or night, up to six miles away. At two pounds (with a collapsible 4.5-foot wingspan), it’s easy to transport.

Notable Feature: Built of injection-molded expanded polypropylene and fitted with Kevlar skids, the Desert Hawk is as durable as a Nerf.¹⁵² The Desert Hawk III is designed for portability, quick mission planning, hand launched and skid recovery, multi-mission versatility, enhanced day/night target detection, recognition, identification, greater operational range, endurance and covert operations. Desert Hawk III provides persistent surveillance by the use of a gyro-stabilized 360-degree sensor turret, color and low light electro-optical plug-and-play payloads, and roll-stabilized infrared sensor payloads. It consists of a rugged air vehicle and a lightweight, portable ground station, which provides operator training, autonomous pre-flight planning, in-flight control of plug-and-play optical and infrared sensors, terrain avoidance measures, and the ability to provide real time dynamic in-flight mission and flight profile re-tasking.¹⁵³

¹⁵² Popular Science Magazine The Complete UAV Field Guide
<http://www.popsci.com/technology/gallery/2010-02/gallery-future-drones>, accessed May 15, 2010.

¹⁵³ Lockheed Martin “Desert Hawk III”
<http://www.lockheedmartin.com/products/DesertHawk/index.html>, accessed May 15, 2010.

B.2.1.7. MD4-200 (Microdrone)



Figure 103. Microdrone MD4-200¹⁵⁴

Habitat: Used by the police in Liverpool, UK as an Anti-social Behavior Task Force.

Behavior: The Microdrone, as shown in [Figure 103.](#), is a four-rotor design of the battery-powered, carbon-fiber pod, which weighs just 2.2 pounds, allows it to take off and land vertically. Brushless, direct-drive electric motors keep the noise level below 64 decibels, according to the company.

Notable Feature: If it loses signal or senses a low battery, it will land itself autonomously rather than crash.¹⁵⁵ Drone has been designed completely in carbon fiber reinforced plastics, which makes it light and shields against electromagnetic interferences. Depending on payload, temperature and wind the vehicle achieves up to 20 minutes of flight time.¹⁵⁶

¹⁵⁴ Microdrone MD4-200, <http://www.gedop.org/blog/galeri/insansiz-casus-ucaklar>, accessed May 15, 2010.

¹⁵⁵ Popular Science Magazine The Complete UAV Field Guide <http://www.popsci.com/technology/gallery/2010-02/gallery-future-drones>, accessed May 15, 2010.

¹⁵⁶ Micro Drones “MD4-200” http://www.microdrones.com/en_md4-200_introduction.php, accessed May 15, 2010.

B.2.1.8. T-Hawk/gMAV (Honeywell)



Figure 104. Honeywell T-Hawk/gMAV.¹⁵⁷

Habitat: Utilized by the U.S. Army infantry in Iraq.

Behavior: T-Hawk, as shown in [Figure 104](#), provides EOD the ability to view an EOD incident from a perspective other than that of a ground robotic system.¹⁵⁸

Notable Feature: VTOL T-Hawk weighs 16 pounds and can fly up to 10,000 feet for up to 45 minutes.

¹⁵⁷ Honeywell T-Hawk/gMAV. <http://www.gedop.org/blog/galeri/insansiz-casus-ucaklar>, accessed May 15, 2010.

¹⁵⁸ BNET “Navy Buys 90 Honeywell Micro Air Vehicles for EOD Teams” http://findarticles.com/p/articles/mi_6712/is_27_240/ai_n31060866/, accessed May 15, 2010.

B.2.1.9. Aerosonde (AAI Corporation)



Figure 105. AAI Corporation Aerosonde¹⁵⁹

Habitat: Stormy seas, or any other inhospitable or inaccessible spot scientific researchers want to study up close.

Behavior: Aerosonde, as shown in [Figure 105.](#), was the first UAV to cross the Atlantic Ocean, back in 1998, the 9.8-foot, 28-pound research craft can fly up to 30 hours on a single tank of gas. In 2007 it delivered unprecedented weather readings from Hurricane Noel, loitering as low as 300 feet above the surface, and streaming data for more than seven hours before it was ditched in the ocean. ¹⁶⁰

Notable Feature: The inverted V tail combines functions of what would be the horizontal and vertical parts of the tail wing, saving weight. It has one horsepower.

¹⁵⁹ AAI Corporation Aerosonde, <http://www.gedop.org/blog/galeri/insansiz-casus-ucaklar>, accessed May 15, 2010.

¹⁶⁰ Popular Science Magazine The Complete UAV Field Guide <http://www.popsci.com/technology/gallery/2010-02/gallery-future-drones>, accessed May 15, 2010.

With a full electro-optic/infrared payload, the Aerosonde aircraft can achieve more than 10 hours endurance. It can land via belly or net capture using AAI's proprietary launch and recovery trailer, or LRT, system with Soft Hands™ recovery technology.

With these capabilities, the Aerosonde aircraft has accumulated several significant flight milestones including¹⁶¹:

- The Aerosonde Mark 4.7 was showcased at the 2010 Bahrain Air Show, where the flight team conducted the system's first flights in the Middle East region. These included a flight during a driving sand storm, which displayed the aircraft's rugged, all-weather capability.
- In 2009, the Aerosonde Mark 4.7 system was introduced to provide expeditionary intelligence, surveillance and reconnaissance. Including the novel Soft Hands net recovery technology, the system rounded out the year with a successful shipboard launch and recovery demonstration off the M-80 Stiletto ship.
- In 2007, an Aerosonde was the first unmanned aircraft to penetrate the eye of a hurricane. Under a program administered by NASA and the U.S. National Oceanic and Atmospheric Administration, the Aerosonde aircraft flew a mission of more than 17 hours, a record 7.5 of which were spent navigating Hurricane Noel's eye and boundary layer.
- During 2006, the aircraft set a world flight endurance record in its class by remaining in flight without refueling for more than 38 hours.

¹⁶¹ Aerosonde "Products and Services" <http://www.aerosonde.com/products/products.html>, accessed May 15, 2010.

B.2.1.10. FINDER (Naval Research Laboratory)



Figure 106. NRL FINDER¹⁶²

Habitat: The wing-mounted weapons pylons beneath Predator drones, from which it is launched.

Behavior: The Flight Inserted Detection Expendable for Reconnaissance (FINDER) is 5ft 3in long and weighs 58 pounds. It can be flown via the Predator controls and directed to a smoke plume to sniff out chemical weapons or under a cloudbank to get a closer view of a potential target.¹⁶³

Notable Feature: It launches like a rocket from the predator, and then its wings unfold.

The goal is to exhibit a capability to determine the presence of chemical agents following an attack on a Weapons of Mass Destruction (WMD) facility. The

¹⁶² NRL FINDER, <http://www.nrl.navy.mil/research/nrl-review/2003/simulation-computing-modeling/cross/>, accessed May 15, 2010.

¹⁶³ Popular Science Magazine The Complete UAV Field Guide <http://www.popsci.com/technology/gallery/2010-02/gallery-future-drones>, accessed May 15, 2010.

FINDER will autonomously fly to a designated recovery site, at which it will autonomously land and be recovered by friendly forces. The FINDER has a propulsion system that used Predator aviation fuel and is able to sustain flight for 8 to 10 hours at 70 km/h airspeed which translates into an operational range of more than 350 nm.

Summary: FINDER supports the European Command requirements for a chemical battle damage assessment tool. The vehicle and current payload provides real time or near real time: local area meteorological data, integration with the existing Predator infrastructure, Predator stand-off capability, critical sample collection, return of sample to a safe area, and extended range egress.

As technology evolves, FINDER possesses the flexibility to accept a wide variety of modular payloads and deployment options. [Figure 106.](#) shows a demonstrated deployment alternative that was a fallout of the normal vehicle development. Future growth capabilities are already being discussed as follow-on options¹⁶⁴:

- Toxic chemical/precursors sensing
 - IMS detectors reprogrammable to add new signatures;
- Biological detection capability
 - Preliminary study of mature technologies
 - Flexibility for future payload integration options;
- NAVY at-sea base option
 - Rail launch future capability is feasible;
- Radiological hazard sensing
 - Flexibility for future payload integration options.

¹⁶⁴ Navy Research Laboratory “ Finder UAV: A Counterproliferation Asset” <http://www.nrl.navy.mil/research/nrl-review/2003/simulation-computing-modeling/cross/>, accessed May 15, 2010.

B.2.1.11. RQ-7 Shadow (AAI)



Figure 107. AAI RQ-7 Shadow¹⁶⁵

Habitat: Iraq and Afghanistan, where Army battalions need tactical surveillance.

Behavior: The Shadow, as shown in [Figure 107](#), is launched from a catapult, stays aloft for five to six hours up to 14,000 feet, and lands autonomously on wheels, with the help of a net. It's a little more than 11 feet long, weighs 375 pounds and has a wingspan of 14 feet.

Notable Feature: With its infrared illuminator, it can laser-pinpoint targets for laser-guided missiles and bombs. The most critical element of the system is its electro-optical/infrared real-time relay camera held underneath the fuselage. The camera is gimbal-mounted and digitally-stabilized.¹⁶⁶

¹⁶⁵ AAI RQ-7 Shadow, <http://www.gedop.org/blog/galeri/insansiz-casus-ucaklar>, accessed May 15, 2010.

¹⁶⁶ Military Factory, "AAI Corporation RQ-7 Shadow 200 Tactical", http://www.militaryfactory.com/aircraft/detail.asp?aircraft_id=326, accessed May 15, 2010.

B.2.1.12. Heron (Israeli Aerospace Industries)



Figure 108. Israeli Aerospace Industries Heron¹⁶⁷

Habitat: Watching over Israel, patrolling India’s borders with Pakistan and China, looking for drug traffickers in El Salvador, and dozens of other missions around the globe, where the unarmed surveillance craft is used by countries importing it from Israel.

Behavior: With a 54-foot wingspan and max altitude ceiling of 30,000 feet, the Heron, as shown in [Figure 108.](#), uses an advanced collection of sensors to stream data to its handlers. It can stay aloft for 52 hours.

Notable Feature: The Heron can take off and land autonomously, even in poor weather conditions¹⁶⁸:

The HERON I main features and capabilities are:

- Multiple operational configurations
- Adverse weather capability
- Safe, reliable and easy operation

¹⁶⁷ Israeli Aerospace Industries Heron, <http://www.gedop.org/blog/galeri/insansiz-casus-ucaklar>, accessed May 15, 2010.

¹⁶⁸ Israeli Aerospace Industries “Heron” http://www.iai.co.il/18900-16382-en/BusinessAreas_UnmannedAirSystems_HeronFamily.aspx?bt1=1, accessed May 15, 2010.

- Simultaneously 4 sensors use capability
- Satellite communication for extended range (SATCOM)
- Two proven simultaneous Automatic Takeoff and Landing (ATOL) systems for maximal safety
- Fully redundant, state-of-the-art avionics
- Retractable landing gear

B.2.1.13. *Hermes 450/Watchkeeper (Elbit Systems)*



Figure 109. Elbit Systems Hermes 450/Watchkeeper¹⁶⁹

Habitat: Providing target coordinates over Israeli battlefields, and reconnaissance for British troops in Iraq and Afghanistan.

Behavior: It can loiter for about 20 hours on its 34-foot wing, up to an altitude of 18,000 feet, providing real-time surveillance to battlefield commanders.

Notable Features: The odd, torpedo-on-a-popsicle-stick design give the craft a high payload to weight ratio: one third of its 992 pounds. It has two gimbals, fore and aft, for surveillance gear. The UAV is equipped with sophisticated

¹⁶⁹ Elbit Systems Hermes 450/Watchkeeper, <http://www.gedop.org/blog/galeri/insansiz-casus-ucaklar>, accessed May 15, 2010.

communication systems transmitting imagery in real time to ground stations. Selected as the base line for the UK WATCHKEEPER program, Hermes[®] 450, as shown in [Figure 109](#), is recognized as the leading long endurance tactical UAV in its class, having flown in U.S. operations and history-making flights in UK civil airspace. To date, the Hermes[®] 450 has accumulated more than 65,000 flight hours.¹⁷⁰

B.2.1.14. MQ-5 Hunter (Northrup Grumman)



Figure 110. Northrup Grumman MQ-5 Hunter¹⁷¹

Habitat: Flown by the Army in Iraq and Afghanistan.

Behavior: The Hunter, as shown in [Figure 110](#), has been in service since just before the Balkans war, and was recently retrofitted in the MQ variant to run on heavy fuel and carry Viper Strike munitions. It has a 34-foot wingspan and can fly 18 hours, up to 18,000 feet.

Notable Feature: It can be flown with the same ground control station as the Shadow and the Army's version of the Predator.¹⁷²

¹⁷⁰ Elbit Systems "Hermes 450" <http://www.elbitsystems.com/lobmainpage.asp?id=161> accessed May 15, 2010.

¹⁷¹ Northrup Grumman MQ-5 Hunter, <http://www.gedop.org/blog/galeri/insansiz-casus-ucaklar>, accessed May 15, 2010.

B.2.1.15. RQ-4 Global Hawk (Northrop Grumman)



Figure 111. Northrop Grumman RQ-4 Global Hawk¹⁷³

Habitat: High above Iraq, Afghanistan and Pakistan—or anywhere else the U.S. Central Command wants to keep under watch.

Behavior: Soaring at 65,000 feet with an endurance of 36 hours, the Global Hawk, as shown in [Figure 111.](#), can keep watch over 40,000 nautical square miles per mission. Carrying a full suite of electro-optical, infrared and synthetic aperture radar sensors, it can operate day and night in all weather conditions. The larger variation has a 130-foot wingspan.

Notable Feature: The fact that it can take off and land autonomously greatly reduces the potential for crashes, which have handicapped the Predator and Reaper.

The Northrop Grumman RQ-4 Block 10 Global Hawk is currently supporting the U.S. Air Force in the global war on terrorism. The Global Hawks are

¹⁷² Popular Science Magazine The Complete UAV Field Guide <http://www.popsci.com/technology/gallery/2010-02/gallery-future-drones>, accessed May 15, 2010.

¹⁷³ Northrop Grumman RQ-4 Global Hawk, <http://www.gedop.org/blog/galeri/insansiz-casus-ucaklar>, accessed May 15, 2010.

operated overseas by USAF pilots from a mission control element stationed at Beale Air Force Base in Northern California. A launch and recovery element and a combined USAF and Northrop Grumman team are forward deployed with the air systems. The Global Hawk is equipped with electro-optical, infrared and synthetic aperture radar sensors to provide high-quality real-time imagery.¹⁷⁴

B.2.2. Future Unmanned Aerial Vehicles

B.2.2.1. Phantom Ray (Boeing Company)



Figure 112. Boeing Phantom Ray¹⁷⁵

Habitat: Edwards Air Force Base, Lancaster, California

Behavior: Derived from the Boeing Phantom Works' defunct X-45C. The prototype Phantom Ray, as shown in [Figure 112.](#), jet-powered flying wing has morphed into a test bed for advanced UAV technologies, including electronic warfare tools like radar jamming, autonomous aerial refueling, air-missile defense and

¹⁷⁴ Northrup Grumman "Global Hawk"
<http://www.as.northropgrumman.com/products/ghrq4a/index.html> accessed May 15, 2010.

¹⁷⁵ Boeing Phantom Ray, <http://www.gedop.org/blog/galeri/insansiz-casus-ucaklar>, accessed May 15, 2010.

surveillance. Engineers expect it to fly at up to 40,000 feet. With an anticipated cruising speed of up to 610 mph, the Phantom Ray will be one of the fastest UAVs on record.¹⁷⁶

Notable Feature: Its unusual shape allows it to evade radar. For Boeing, Phantom Ray and other prototyping projects are keeping a small cadre of engineers focused on designing next-generation concepts and engaged in flight-test efforts. They are also forcing the design team to be as lean as possible because of limited funding, and allowing the company to experiment with operational use of an aircraft built using some unconventional manufacturing processes.¹⁷⁷

¹⁷⁶ Popular Science Magazine The Complete UAV Field Guide
<http://www.popsi.com/technology/gallery/2010-02/gallery-future-drones>, accessed May 15, 2010.

¹⁷⁷ Aviation Week “The Phantom Ray”
http://www.aviationweek.com/aw/generic/story_generic.jsp?channel=defense&id=news/PHANTOM050809.xml&headline=Boeing%20Unveils%20Phantom%20Ray%20Combat%20UAS, accessed May 15, 2010.

B.2.2.2. Demon BAE Systems



Figure 113. BAE Systems Demon¹⁷⁸

Habitat: BAE Systems laboratory in London

Behavior: The Demon, as shown in [Figure 113.](#), flies with no fins and almost no moving parts, so it rarely needs repairs. Software makes it partially autonomous.

Notable Features: The entire body of the craft is shaped like a wing. Dozens of thrusters situated on its top and bottom shape airflow, replacing the work typically done by tail fins and ailerons. Onboard software varies the strength of each thruster to control pitch, side-to-side movement (yaw) and roll. Its major focus is to develop the technologies needed to build a low-cost, low maintenance UAS with no

¹⁷⁸ BAE Systems Demon, <http://www.gedop.org/blog/galeri/insansiz-casus-ucaklar>, accessed May 15, 2010.

conventional control surfaces, such as wing flaps and without losing any performance compared to conventional aircraft.¹⁷⁹

B.2.2.3. Vulture Jim (Lockheed Martin)



Figure 114. Lockheed Martin Vulture Jim¹⁸⁰

Habitat: A belt of relatively calm air around 55,000 feet

Behavior: The Vulture Jim, as shown in [Figure 114.](#), can stay aloft for five years, turning lazy circles above any patch of ground that needs continuous monitoring. A suite of day-and-night cameras can scan a 600-mile swath, sending data back to handlers on the ground. The craft will have to beat out species from a Boeing-led consortium and Virginia-based Aurora Flight Sciences for a second round of funding.

¹⁷⁹ BAE Systems “Demon”
<http://www.artisan3d.co.uk/Capabilities/Technologyinnovation/NewTechnologies/Demon/index.htm>, accessed May 15, 2010.

¹⁸⁰ Lockheed Martin Vulture Jim, <http://www.gedop.org/blog/galeri/insansiz-casus-ucaklar>, accessed May 15, 2010.

Notable Feature: The craft's semi-flexible structure bends instead of breaking when winds cause the long span to oscillate violently.¹⁸¹

B.2.2.4. RQ-170 Sentinel (Lockheed Martin)



Figure 115. Lockheed Martin RQ-170 Sentinel¹⁸²

Habitat: Migrating from its suspected home base at Kandahar Airfield, Afghanistan, this top-secret military spy drone makes classified sorties into enemy terrain.

Behavior: An offspring of Lockheed Martin's Skunk Works program, the RQ-170 Sentinel, as shown in [Figure 115.](#), flies via satellite link from a base in Tonopah, Nevada, but little else is know about it.

Notable Feature: Sensor pods built into the edge of its wings probably give it surveillance capabilities, and the absence of a wing-mounted weapons payload likely keeps it light and off the radar.¹⁸³

¹⁸¹ Wired Magazine "War Drones of Now and Tomorrow"
http://www.wired.com/beyond_the_beyond/2010/03/war-drones-of-now-and-tomorrow/, accessed May 15, 2010.

¹⁸² Lockheed Martin RQ-170 Sentinel, <http://www.gedop.org/blog/galeri/insansiz-casus-ucaklar>, accessed May 15, 2010.

B.2.2.5. *Embla (Aesir)*



Figure 116. Aesir Embla¹⁸⁴

Habitat: Afghanistan and disaster zones. About the size and shape of a spare tire, the Embla lifts straight up from the ground without the need for a runway, making it more useful to combat soldiers stationed in rough terrain. Its diminutive size lets it zoom down urban canyons to find hard-to-reach enemy hideouts, and it can send video to a remote PDA-size controller, revealing potential ambushes. Loaded with explosives, it could even enter an enemy compound on a suicide mission.

185

¹⁸³ Popular Science Magazine The Complete UAV Field Guide
<http://www.popsci.com/technology/gallery/2010-02/gallery-future-drones>, accessed May 15, 2010.

¹⁸⁴ Aesir Embla, <http://www.gedop.org/blog/galeri/insansiz-casus-ucaklar>, accessed May 15, 2010.

¹⁸⁵ Popular Science Magazine The Complete UAV Field Guide
<http://www.popsci.com/technology/gallery/2010-02/gallery-future-drones>, accessed May 15, 2010.

Behavior: The Embla, as shown in [Figure 116.](#), can change direction on a dime, fly at 50 mph, and climb to 10,000 feet. It also has the ability to hover in place to, for instance, transmit encrypted HD video.

Notable Feature: Whereas a ducted fan funnels air straight down to generate lift, the Embla's turbine sucks air in through its top and forces it out through a skirt-like wing. This design bends the flow toward the ground. This makes Embla strong enough to carry cameras, weapons and sensors on its belly, oriented toward the terrain it's watching.¹⁸⁶

B.2.2.6. Ion Tiger (Naval Research Laboratory)



Figure 117. NRL Ion Tiger¹⁸⁷

Habitat: European airfields, potentially, from which it could reach the Middle East, once the Navy perfects the fuel-cell technology inside. It could fly as low as 1,000 feet without being heard on the ground, or as high as 14,000 feet.¹⁸⁸

¹⁸⁶ Aesir "News" <http://www.aesir-uas.com/news.htm>, accessed May 15, 2010. 2010.

¹⁸⁷ NRL Ion Tiger, <http://www.gedop.org/blog/galeri/insansiz-casus-ucaklar>, accessed May 15, 2010.

¹⁸⁸ Popular Science Magazine The Complete UAV Field Guide <http://www.popsci.com/technology/gallery/2010-02/gallery-future-drones>, accessed May 15, 2010.

Behavior: Its ability to stay aloft for 24 hours allows the Ion Tiger, as shown in [Figure 117](#), to encroach on the terrain of much bigger birds, such as the Predator, and its small size lets it get closer to a target to shoot footage with its lighter, cheaper camera.

Notable Feature: Its carbon-wrapped aluminum hydrogen tanks weigh only about nine pounds each, which helps this UAV stay airborne longer. The U.S. Navy is converging two separate research efforts — unmanned air vehicles (UAVs) and fuel cell systems — to significantly improve battlefield surveillance capability. The Ion Tiger is a hydrogen-powered fuel cell UAV in development at the Naval Research Laboratory, the corporate laboratory of the Office of Naval Research (ONR). Previously flown with battery power, it has demonstrated sound aerodynamics, high functionality, and low-heat and noise signatures. Test flights of Ion Tiger have exceeded 24 hours with a 6 lb payload. Tests demonstrated how an enduring surveillance solution can operate at a low cost with less possibility of detection. The trials exceeded previous flight duration seven-fold from previous designs. Across the board, the military is seeking quieter and more efficient sources of energy. ONR is leading the Navy with support for alternative fuel research, and has been a leader and key supporter of fuel cell research for 20 years. By leveraging other ONR research, and cooperating with partner agencies, ONR and its partners anticipate success in this mission.¹⁸⁹

¹⁸⁹ Office of Naval Research “Ion Tiger” <http://www.onr.navy.mil/en/Media-Center/Fact-Sheets/Ion-Tiger.aspx>, accessed May 15, 2010.

B.2.2.7. Excalibur McArdle Productions



Figure 118. McArdle Productions Excalibur¹⁹⁰

Habitat: Future war zones, on land and at sea. If Aurora Flight Sciences can scale up the prototype, Excalibur, as shown in [Figure 118.](#), could be deployed on the battlefield within five years.

Behavior: Unlike Air Force drones, which are flown by operators stateside and are in short supply, the Excalibur can be remotely operated from wherever it's deployed—the mountains of Afghanistan or the helipad of a ship—providing immediate tactical support to Army, Navy and Marine troops. It can take off and land without a runway and flies at 30,000 feet. Fitted with 400 pounds of laser-guided munitions, including Hellfire missiles, the hybrid turbine-electric Excalibur strikes enemy targets up to 600 miles away from its handler. It can loiter and inspect the damage with a suite of infrared or electro-optical surveillance cameras and follow anyone who gets away.

¹⁹⁰ McArdle Productions Excalibur, <http://www.gedop.org/blog/galeri/insansiz-casus-ucaklar>, accessed May 15, 2010.

Notable Feature: After takeoff, the jet engine pivots in-line with the fuselage, and the lift turbines retract inside the wing section for forward flight. It travels at a brisk 530 mph—twice as fast as a helicopter.¹⁹¹ It is powered by a turbine engine, placed in oblique position, generating thrust and lift for forward flight and rotating into vertical, for take-off and landing. The turbine generates sufficient thrust to accelerate the vehicle to dash speed, in excess of 300 knots, enabling the Excalibur to reach flash points in half the time of an attack helicopter. The UAV can also loiter over the target area for much longer, even after flying long distances. Excalibur uses a unique three-fan design to lift augmentation for vertical takeoff and landing. The battery powered lift fans are embedded in the wings and fuselage. The wing stored fans slide out to augment turbine thrust during takeoff and landing. Excalibur will be cleared for operation at altitudes up to 40,000 feet, and 3 hours flight endurance.

The flight control system will be designed to enable high level of autonomy, since the aircraft is not be remotely piloted, like current Predators, operators are able are expected to focus on mission planning, finding, and engaging targets instead of flying the aircraft.

Excalibur is under development as a technology demonstrator aircraft, funded by the US Army's Aviation Applied Technology Directorate. Excalibur is scheduled for flight in 2007 pending availability of funds.

Highly autonomous flight control system will reduce human involvement in controlling the platform, enabling the operator to focus on mission planning, finding, and engaging targets. The Excalibur, designed by Aurora, is scheduled for flight in 2007. General Dynamics Robotics Systems (GDRS) is responsible for the ground control station and data links.¹⁹²

¹⁹¹ Popular Science Magazine The Complete UAV Field Guide <http://www.popsci.com/technology/gallery/2010-02/gallery-future-drones>, accessed May 15, 2010.

¹⁹² Defense Update “Excalibur Armed VTOL UAV” <http://defense-update.com/products/e/excalibur-UAV.htm>, accessed May 15, 2010.

B.2.2.8. S-100 Camcopter (Schiebel)



Figure 119. Schiebel S-100 Camcopter¹⁹³

Habitat: Warships, borders, forest fires, mob scenes

Behavior: Made by Austrian electronics manufacturer Schiebel, the Camcopter, as shown in [Figure 119](#), can take off and land autonomously from a half-sized helipad and fly for six hours with a 75-pound payload at 120 knots. Fitted with its standard infrared and daytime cameras, it can hover at up to 18,000 feet and watch anything from troop movements to illegal border crossings to spreading forest fires.¹⁹⁴

Notable Feature: Separate controls for the vehicle and the cameras or payload allow for complex missions, such as deploying tear gas over a crowd. The Aerial Vehicle (UAV) combines long endurance and large payload capacity into a relatively small outline.

The UAV can complete its entire mission automatically, from takeoff to landing, controlled by a triple-redundant flight computer based on proven flight control methods and algorithms. Redundant INS and GPS modules ensure precision navigation and stability in all phases of flight, ensuring that the payload is accurately positioned in

¹⁹³ Schiebel S-100 Camcopter, <http://www.gedop.org/blog/galeri/insansiz-casus-ucaklar>, accessed May 15, 2010.

¹⁹⁴ Popular Science Magazine The Complete UAV Field Guide <http://www.popsci.com/technology/gallery/2010-02/gallery-future-drones>, accessed May 15, 2010.

accordance with its tasking. The onboard navigation computer is capable of storing and managing all waypoint commands, allowing continuous operation independent of the control station. The datalink receives control inputs from, and transmits position and payload data to, the control station in real-time. Mission radius is dependent upon the user-specified ground antenna configuration, and payload weight.¹⁹⁵

B.2.2.9. Skylite (BAE Systems)



Figure 120. BAE Systems Skylite¹⁹⁶

Habitat: Israeli borders

¹⁹⁵ Schiebel “Aerial Vehicle” http://www.schiebel.net/pages/cam_air.html, accessed May 15, 2010.

¹⁹⁶ BAE Systems Skylite, <http://www.gedop.org/blog/galeri/insansiz-casus-ucaklar>, accessed May 15, 2010.

Behavior: Equipped with cameras and sensors, SkyLite, as shown in [Figure 120](#), typically flies up to 36,000 feet, the same altitude as commercial airplanes, providing a bird's-eye view of enemy terrain and movement.¹⁹⁷

Notable Feature: Fits in a backpack and can stay aloft for four hours on a single charge.

This family includes the SkyLite A, a canister-launched mini-UAV, and the SkyLite B mini-UAV. Both mini-UAVs utilize an electro-optic payload that is stabilized and outfitted with gimbals. The SkyLite B is mainly intended for use by infantry forces deployed up to battalion level and is capable of staying aloft for more than one-and-a-half hours and handles weather changes well. A major innovation of the new mini-UAV is its immediate reusability, which is enabled by landing the vehicle with a parachute and air bag and launching it using a catapult. In addition, the SkyLite B is characterized by simple operation of advanced command modes from a ground station.¹⁹⁸

¹⁹⁷ Popular Science Magazine The Complete UAV Field Guide
<http://www.popsci.com/technology/gallery/2010-02/gallery-future-drones>, accessed May 15, 2010.

¹⁹⁸ Space War “Rafael Demonstrates Skylite B Mini-UAV”
http://www.spacewar.com/reports/Rafael_Demonstrates_Skylite_B_Mini_UAV_Yo_Israel_Defense_Forces.html, accessed May 15, 2010.

B.2.2.10. MANTIS (BAE Systems)



Figure 121. BAE Systems MANTIS¹⁹⁹

Habitat: Up to 40,000 feet above any battlefield, disaster site or border, relaying intelligence data back to controllers on the ground

Behavior: Can be sent on a mission with a push of a button. From there, it can calculate flight plans, fly around obstacles, and check in with ground controllers when it spots something interesting, like smoke or troop movement. At the end of the mission, it flies home and lands itself.²⁰⁰

Notable Feature: MANTIS, as shown in [Figure 121](#), is the first in a new breed of smart drones. A craft that can hone its searches requires less bandwidth than those that constantly stream images. Mantis can also monitor itself for damage—a

¹⁹⁹ BAE Systems MANTIS, <http://www.gedop.org/blog/galeri/insansiz-casus-ucaklar>, accessed May 15, 2010.

²⁰⁰ Popular Science Magazine The Complete UAV Field Guide <http://www.popsci.com/technology/gallery/2010-02/gallery-future-drones>, accessed May 15, 2010.

sputtering engine, for example—and adjust its electronics to complete a mission. It can fly up to 345 miles an hour and operate for up to 36 hours. Other Keu features are:²⁰¹

- MANTIS is BAE Systems' first all-electric aircraft.
- MANTIS is a fully autonomous next generation unmanned aircraft system.
- The system is designed to be easily deployable and can be broken down to fit into a military transport aircraft.
- MANTIS is designed to be a real workhorse with "plug and play" elements in the mission system and the ability to carry a wide range of sensors.
- MANTIS can execute its mission with a much reduced need for human intervention by understanding and reacting to its environment. Such autonomy increases operational effectiveness allowing more focus on the mission without the usual concerns over vehicle control. It also reduces the manpower requirements and the risk of accidents due to human error and the communications/data link requirements between the vehicle and the ground.

²⁰¹ BAE Systems "Mantis" http://www.baesystems.com/ProductsServices/bae_prod_mantis.html, accessed May 15, 2001.

B.2.2.11. Predator-C Sea Avenger (General Atomics)

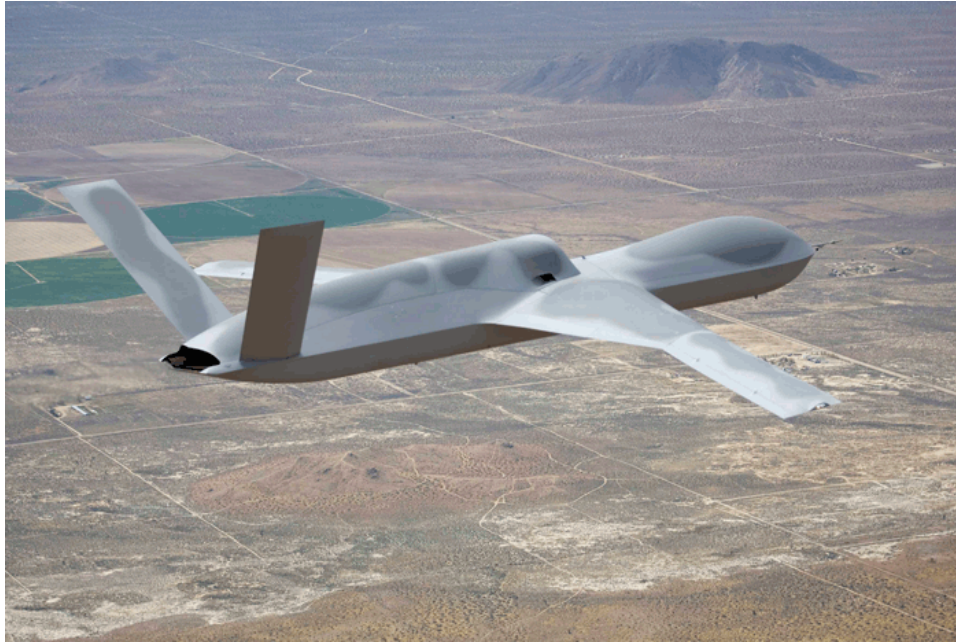

Figure 122. General Atomics Predator C Sea Avenger UAV²⁰²

Habitat: Flight-operations center for General Atomics Aeronautical Systems in Palmdale, California.

Behavior: The stealthy jet-powered Avenger, as shown in [Figure 122](#), is packed with 3,000 pounds of surveillance equipment and lethal munitions, such as laser-guided Hellfire missiles and 500-pound GBU-38 bombs. It can reach speeds of up to 530 mph, far faster than its spindly predecessors, the Predator and Reaper. With fuel packed into every available nook of the fuselage, it can loiter above a target for nearly 20 hours.²⁰³

Notable Feature: Its internal weapons bay allows for interchangeable payloads, such as next-generation wide-area surveillance sensors. General Atomics

²⁰² General Atomics Predator C Sea Avenger UAV, <http://air-news.blog.onet.pl/Pierwszy-lot-Predatora-C.2.ID374472830.n>, accessed May 15, 2010.

²⁰³ Popular Science Magazine The Complete UAV Field Guide <http://www.popsci.com/technology/gallery/2010-02/gallery-future-drones>, accessed May 15, 2010.

declines to comment about rumors that the Avenger, is designed to fly to up to 60,000ft.²⁰⁴

B.2.2.12. Zephyr (QinetiQ)



Figure 123. QinetiQ Zephyr²⁰⁵

Habitat: 50,000 feet above Yuma, Arizona, where London-based manufacturer QinetiQ is testing prototypes.

Notable Feature: Less than 100 pounds, 75-foot wingspan. QinetiQ has completed the first flight trials of Zephyr, as shown in [Figure 123.](#), - a High-Altitude, Long-Endurance Unmanned Aerial Vehicle (HALE UAV). This ultra-light

²⁰⁴ Flight Global “General Atomics Attracts First Customers for Avenger UAV” <http://www.flightglobal.com/articles/2010/02/18/338541/general-atomics-attracts-first-customer-for-avenger-uav-claims.html>, accessed May 15, 2010.

²⁰⁵ QinetiQ Zephyr, <http://www.gedop.org/blog/galeri/insansiz-casus-ucaklar>, accessed May 15, 2010.

aircraft is solar-electric powered, autonomous. The combination of solar panels on the upper wing surface and rechargeable batteries allows Zephyr to be flown for durations of many weeks and even months.²⁰⁶

B.2.2.13. HALE (High Altitude Long Endurance) (Boeing)



Figure 124. Boeing HALE²⁰⁷

Habitat: 65,000 feet above future battlefields, where it will provide 24/7 surveillance and data communication.

Notable Feature: The High Altitude Long Endurance (HALE) plane, as shown in [Figure 124](#), stays up for 10 days, powered by a Ford truck engine modified to run on hydrogen fuel. It weighs 7 tons and has a wingspan of 250 feet.

Another system under development by Aurora Flight Science and Boeing is the Orion, High Altitude, Long Loiter (HALL) Unmanned Aerial System. This stratospheric platform will be able to cruise at an altitude of 65,000 ft for about 100 hours, powered by reciprocating engines consuming liquid hydrogen fuel. With a gross

²⁰⁶ QinetiQ “QinetiQ Announces First Flight Trail for Zephyr UAV” http://www.qinetiq.com/home/newsroom/news_releases_homepage/2006/1st_quarter/First_flight_trial_for_Zephyr_Unmanned_Aerial_Vehicle.html, accessed May 15, 2010.

²⁰⁷ Boeing HALE, <http://www.gedop.org/blog/galeri/insansiz-casus-ucaklar>, accessed May 15, 2010.

takeoff weight of 7,000 lbs (3.175 tons) HALL will be able to carry payloads weighing about 400 lbs (181kg). The U.S. Army/SMDC is supporting a team lead by Aurora and Boeing as a strategic partner, developing two Orion HALL platforms, to demonstrate the new technology.²⁰⁸

B.2.2.14. Global Observer (AeroVironment)



Figure 125. AeroVironment Global Observer²⁰⁹

Habitat: Made by Monrovia, California’s AeroVironment, Global Observer, as shown in [Figure 125](#), will circle up to 65,000 feet above battlefields, disaster sites, borders—any locale in need of aerial surveillance or a wireless data link.

Notable Feature: Liquid hydrogen powers an electric generator, which drives four propellers. Has a wing Span of 175ft.²¹⁰ The propulsion uses liquid

²⁰⁸ Defense Update “Hale UAVs Come of Age” http://defense-update.com/events/2007/summary/auvsi07_5hale.htm, accessed May 15, 2010.

²⁰⁹ AeroVironment Global Observer, <http://www.gedop.org/blog/galeri/insansiz-casus-ucaklar>, accessed May 15, 2010.

hydrogen fuel and fuel cells to drive 8 small rotary engines set along the wings; as noted above, the goal is 7-day flights. Missions could include:

- Wide-area “persistent stare” reconnaissance for defense and homeland security missions, probably using radars rather than optical payloads as the primary sensors;
- Signals and communications intercepts over a wide area, for long periods of time;
- Low-cost, rapidly deployable augmentation for telecom bandwidth, and even GPS;
- Hurricane/storm tracking, weather monitoring, wildfire detection, and sustained support for relief operations;
- Aerial imaging/mapping, for defense uses or for civilian commercial and environmental monitoring, agriculture crop management and harvesting optimization.²¹¹

²¹⁰ Popular Science Magazine The Complete UAV Field Guide
<http://www.popsci.com/technology/gallery/2010-02/gallery-future-drones>, accessed May 15, 2010.

²¹¹ Defense Industry Daily “ Aerovirments Global Observer, Flying High, Again”
<http://www.defenseindustrydaily.com/aerovirments-global-observer-flying-high-again-03902/>, accessed May 15, 2010.

B.2.2.15. Samarai (Lockheed Martin)

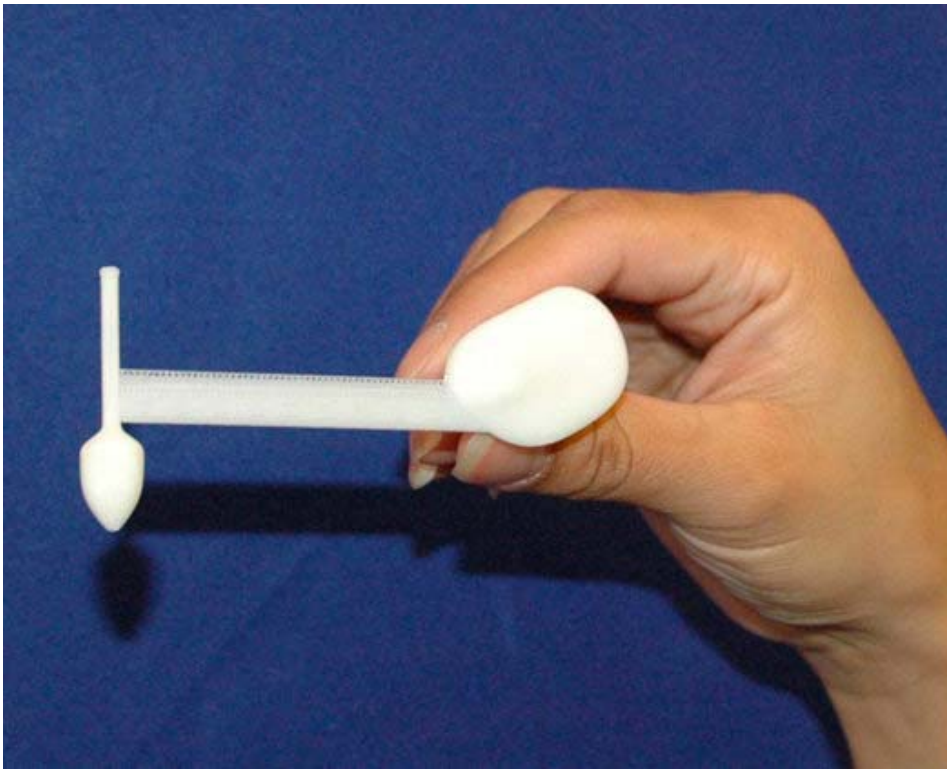

Figure 126. Lockheed Martin Samarai²¹²

Habitat: Lockheed Martin’s Advanced Tech Laboratories in Bethesda, Maryland.

Behavior: The Samarai, as shown in [Figure 126.](#), has a 12-inch wingspan and weighs only 150 grams. Like the spiraling maple-leaf seedlings—more commonly known as whirlybirds—that inspired it, the single wing spins around a central hub to create lift. A miniature jet engine provides thrust. A tiny flap on the trailing edge of the wing, its only moving part, controls direction. If engineers can shrink it to three inches and 15 grams, the autonomous device could be used to spy indoors.²¹³

²¹² Lockheed Martin Samarai, <http://www.gedop.org/blog/galeri/insansiz-casus-ucaklar>, accessed May 15, 2010.

²¹³ Popular Science Magazine The Complete UAV Field Guide <http://www.popsci.com/technology/gallery/2010-02/gallery-future-drones>, accessed May 15, 2010.

Notable Feature: In the future, a camera mounted on the central hub that snaps a picture once every rotation will collect enough images to stitch together full-motion video. Diet: Today, batteries; but engineers plan to feed the next version propane, which is light and readily available in the military supply chain.²¹⁴

²¹⁴ Geekology “Lockeed Martin’s Samurai Monocopter “
http://www.geekologie.com/2009/09/crazy_lockheed_martins_samurai.php, accessed May 15, 2010.

B.3. UNMANNED SURFACE VEHICLES

B.3.1. Protector (Rafael/BAE Systems)

Maritime Unmanned Systems are a newer field than UAV, but they are a growing field. USV can perform everything from port, harbor, and one Navy specific mission of Oil Platform security to combat operation with a battlegroup or surface task force. The Protector, as shown in [Figure 127.](#), is one system under testing was originally designed by the Israeli Company Rafael. Rafael has teamed with BAE (British Aerospace) Systems and Lockheed Martin and Rafael are teamed for product production and all other program developments with Lockheed Martin.²¹⁵



Figure 127. Rafael Protector²¹⁶

²¹⁵ Protector, available from <http://www.lockheedmartin.com/>, accessed January 10, 2010.

²¹⁶ Rafael Protector, <http://snafu-solomon.blogspot.com/2009/12/protector-usvsolution-to-littoral.html>, accessed May 15, 2010.

B.3.2. Antisubmarine Warfare Unmanned Surface Vehicle



Figure 128. Antisubmarine Warfare Unmanned Surface Vehicle²¹⁷

Habitat: Open ocean and littoral regions

Behavior: The Antisubmarine Warfare (ASW) USV, as shown in [Figure 128](#), is the Mission System on the LCS ASW Mission Package. It was designed as a common unmanned surface platform capable of carrying and operating different ASW payloads. The Government's EDM, based on open ocean racing and Rigid Hull Inflatable Boat (RHIB) high-speed vehicles technology, can be fitted with modular ASW payloads and operate with semi-autonomous control and navigation functionality. Current payloads include Unmanned Dipping Sonar (UDS), USV Towed Array System (UTAS) and the Multi-Static Off-Board Source (MSOBS).

Notable Features: The core subsystems include surface search radar and advanced communications. The surface search radar, required for navigation, can also detect incoming threats. The ASW USV is capable of extended-duration operations with a high-payload capacity supporting multiple mission sensor systems enabling high-speed transits to operational areas.²¹⁸

²¹⁷ Fiscal Year 2009-2034 Road Map Unmanned Systems Integrated Roadmap C.1.1.1

²¹⁸ Ibid

B.3.3. Mine Counter Measures (MCM)



Figure 129. Mine Counter Measures (MCM)²¹⁹

Habitat: Littoral and river regions

Behavior: The Mine Counter Measures (MCM) Unmanned Surface Vehicle (USV), as shown in [Figure 129.](#), is the Mission System on the LCS MCM Mission Package. It was selected as the unmanned platform to “get the man out of the minefield” and will be used to tow the Unmanned Surface Sweep System (USSS) to clear minefields.

Notable Features: USV core system controller and communications were developed and integrated at the Naval Surface Warfare Center (NSWC) Panama City. The USV Platform Controller for LCS is compliant with the Joint Architecture for Unmanned Systems (JAUS). Full Functional Tests were completed at Ft. Monroe, VA in June 2008 and validated Functional Requirements.²²⁰

²¹⁹ Fiscal Year 2009-2034 Road Map Unmanned Systems Integrated Roadmap C.1.1.2

²²⁰ Ibid.

B.3.4. SEAFOX



Figure 130. SEAFOX²²¹

Habitat: Riverine and Maritime Interdiction Operations as well as port security.

Behavior: The SEAFOX USV, as shown in [Figure 130.](#), will provide a remote, unmanned ISR capability supporting multiple mission areas.

Notable Features: The SEAFOX USV has a JP-5 jet engine and a payload consisting of a Command and Control, Communications, and Intelligence (C3I) system. The C3I payload has an amplified military band command and control radio, autonomous way-point navigation, amplified communications, and intelligence consisting of: wide bandwidth video, object tracking and dejitter software, digital zoom Infra-Red (IR) camera, digital zoom daylight color camera, 3x70 degree navigation cameras, remote camera operation station, remote ground station, remotely activated flood lighting, remotely activated hailer/announcement system, and navigation/ strobe safety lights. In particular, SEAFOX 1 will have enhanced communications ability with 4 bands (2 MIL, 2 ISM), LCS bands, Unmanned Aircraft System (UAS)

²²¹ SEAFOX, <http://www.nps.edu/Academics/Centers/CAVR/Vehicles/SeaFox.html>, accessed January 10, 2010.

communications, and ranges of approximately 15 nautical mile (NM) Line Of Sight (LOS), 60 NM UAS, and 100 NM relay.²²²

B.4. UNMANNED UNDERWATER VEHICLES

B.4.1. Remus (Hydroid Inc)

From deep sea submersibles for surveying the ocean floor to hunting for submarines to maritime mines UUV have the abilities to greatly enhance our knowledge of the oceans but also increase our battlefield awareness under the waves. One company that is working to make this possible is Hydroid Inc the manufacturers of the Remus UUV, as shown in [Figure 131](#). They currently have three models; the 100, 600, and 6000 which range in size and payload to the capability. The designation refers to the depth obtainable by the UUV in meters.²²³



Figure 131. Hydroid Inc. Remus²²⁴

²²² Fiscal Year 2009-2034 Road Map Unmanned Systems Integrated Roadmap C.1.1.3

²²³ Remus, available from <http://www.hydroidinc.com/remus100.html>, accessed January 10, 2010.

²²⁴ Ibid.

B.4.2. Battlespace Preparation Autonomous Undersea Vehicle (BPAUV) (Naval Research Laboratory)



Figure 132. NRL Battlespace Preparation Autonomous Undersea Vehicle (BPAUV)²²⁵

Habitat: Up to a depth of 300 feet

Behavior: Battlespace Preparation Autonomous Undersea Vehicles (BPAUVs), as shown in [Figure 132.](#), have been employed in Office of Naval Research (ONR) Science and Technology experiments since 1999. The BPAUV provides minehunting and Intelligence Preparation of the Battlespace (IPB) capability. The LCS BPAUV is a demonstration system to mitigate ship integration risk of heavyweight UUVs (especially launch and recovery). The BPAUV system consists of 2 vehicles, support equipment, spares, and a transportation van. The BPAUV system will be shipped and stored in a Sea frame Type 1 module. BPAUV has been delivered to the LCS program as part of Mission Package 1.

Notable Features: The BPAUV can travel at a speed of 3 knots for up to 18 hours and utilizes a Klein 5400 sonar to detect targets. It also can track environmental data.²²⁶

²²⁵ Fiscal Year 2009-2034 Road Map Unmanned Systems Integrated Roadmap C.2.1.1.

²²⁶ Ibid.

B.4.3. Littoral Battlespace Sensing – Autonomous Undersea Vehicle (LBSAUV)

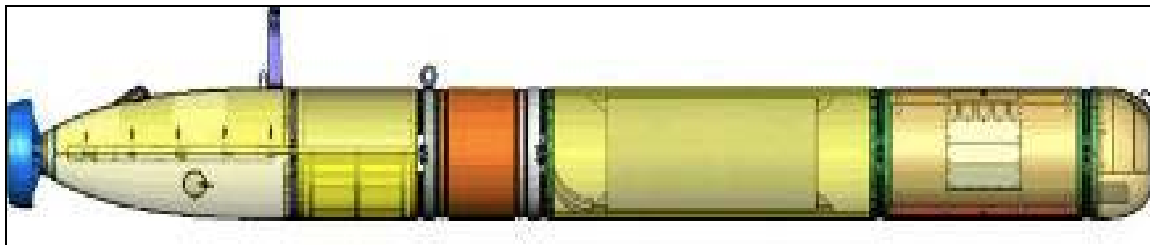

Figure 133. Littoral Battlespace Sensing – Autonomous Undersea Vehicle (LBSAUV)²²⁷

Habitat: Maximum depth of 500 meters

Behavior: The Littoral Battlespace Sensing – Autonomous Undersea Vehicle (LBS-AUV), as shown in [Figure 133](#), is the acquisition POR intended to increase the survey footprint of the T-AGS 60 Multi-Mission Survey Ship, as well as allow clandestine military surveys to be conducted at a greater standoff range, thereby decreasing the risk to the ship and crew.

Notable Features: Can travel at 4 knots for a maximum endurance of 24 hours. Utilizes a Multibeam Bathymetry, Side Scan Sonar, CTD, Optical.²²⁸

²²⁷ Fiscal Year 2009-2034 Road Map Unmanned Systems Integrated Roadmap C.2.1.2.

²²⁸ Ibid

B.4.4. Bottom Unmanned Undersea Vehicle (UUV) Localization System (BULS)



Figure 134. Bottom Unmanned Undersea Vehicle (UUV) Localization System (BULS)²²⁹

Habitat: Maximum depth of 300ft

Behavior: The Bottom UUV Localization System (BULS), as shown in [Figure 134](#), is part of the “toolbox approach” to equipping EOD forces via spiral development of UUVs. It will be capable of detecting and localizing threat objects on the seafloor of harbors and open areas and will support MCM operations from 10 to 300 feet. The system is small (two-person portable) with a low unit cost so that inadvertent loss is not mission-catastrophic. It will be deployable via multiple platforms and from shore.

Notable Features: Current configuration includes dual-frequency side-scan sonar, enhanced navigation (GPS, INS, ultra-short baseline [USBL]), low-light CCD camera, and enhanced acoustic communications (ACOMMS). Future spirals are envisioned to support more complex capabilities, such as detailed intelligence gathering and chemical and biological detection.²³⁰

²²⁹ Fiscal Year 2009-2034 Road Map Unmanned Systems Integrated Roadmap C.2.3.1.

²³⁰ Ibid.

B.5. UNMANNED GROUND VEHICLES

B.5.1. UGV Light

B.5.1.1. Soldier UGV (SUGV)

Habitat: Urban and subterranean operating environments

Behavior: The Soldier UGV (SUGV) is a man-packable small robot system, weighing less than 30 lbs, used to remotely investigate the threat obstacles, structures and the structural integrity of facilities and utilities. SUGV systems will be highly mobile for dismounted forces and will be capable of being re-configured for other missions by adding or removing sensors, modules, mission payloads, and/or subsystems.

Notable Features: The Small Unmanned Ground Vehicle (SUGV) is a remotely operated, man-packable, robotic vehicle. This is a small man-portable vehicle with modular payloads that will allow the SUGV to perform:

- Reconnaissance
- Surveillance
- Assault²³¹

B.5.1.2. Combined Operations Battlefield Robotic Asset (COBRA)

Habitat: COBRA is a Soldier UGV (SUGV) system small enough to be carried by one man over long distances and provide significant increase in effectiveness for small unit operations.

Behavior: The COBRA will be carried by one soldier or disassembled and carried by two (8-30 lbs.). It will be designed for modular multi-mission payloads and be able to operate 4-12 hours. The vehicle will have semiautonomous control and navigation. With on-board sensors, it will be able to:

- Detect and neutralize booby traps and AP mines

²³¹ Ibid.

- Detect NBC presence
- Deploy smoke

Notable Features: Combined Operations Battlefield Robotic Asset [COBRA] is coincident with the Soldier UGV (SUGV) component of the FCS and will be an integrated node on FCS network of systems. The COBRA program is coincident with and supports the Army Future Combat System SUGV.²³²

B.5.1.3. Man Transportable Robotic System (MTRS)

Man Transportable Robotic System [MTRS] consists primarily of an operator control unit (OCU) and a teleoperated vehicle. The system components will be small and light enough to be carried as a single load by a two-person team for 500 meters over semi-rugged terrain. The primary mission is reconnaissance, and the system will be enhanced to perform other EOD tasks.²³³

²³² Combined Operations Battlefield Robotic Asset (COBRA), <http://www.globalsecurity.org/military/systems/ground/fcs-soldier.htm>, accessed May 15, 2010.

²³³ Man Transportable Robotic System (MTRS), <http://www.globalsecurity.org/military/systems/ground/fcs-soldier.htm>, accessed May 15, 2010.

B.5.1.4. Dragon Runner



Figure 135. Dragon Runner²³⁴

Habitat: Urban environment

Behavior: Dragon Runner, as shown in [Figure 135.](#), is a small, four-wheeled, rear-wheel drive, front-wheel steer, man-portable mobile ground sensor designed to increase situational awareness. It will give tactical Marine units the capability to “see around the corner” in an urban environment.

Notable Features: At 15.5 inches long, 11.25 inches wide and five inches high, Dragon Runner will fit inside the standard Modular, Light Weight, Load Carrying Equipment (MOLLE) Patrol Pack. The total system weighs 16 pounds. A non-active and invertible suspension enables Dragon Runner to be tossed through windows, up stairs or over walls for a rapid deployment capability. The user interface features a four-inch video display and home-gaming type controller for vehicle

²³⁴ Dragon Runner, <http://www.globalsecurity.org/military/systems/ground/dragon-runner.htm>, accessed May 15, 2010.

manipulation. The entire system uses standard military radio-type batteries for its power supply.²³⁵

B.5.1.5. Mesa Associates' Tactical Integrated Light-Force Deployment Assembly (MATILDA)



Figure 136. Mesa Associates' Tactical Integrated Light-Force Deployment Assembly (MATILDA)²³⁶

Habitat: Urban environments

Behavior: Operated by radio remote MATILDA, as shown in [Figure 136](#), is a reconnaissance robot used in the role as a point man and is capable of breaching doors or walls with explosives

Notable Features: It weights 40 lbs. and measures 26”L x 20”W x 12”H (platform only). Optional attachments include a small trailer (400 lbs. capacity), a manipulator arm, and a remotely detachable breaching mechanism. Key elements of these evaluations have resulted in the development of a robotic manipulator arm, operator control unit upgrade, light kit, 4-wheel trailer, larger monitor, and an upgraded radio system for extended range.²³⁷

²³⁵ Ibid.

²³⁶ MATILDA, <http://www.globalsecurity.org/military/systems/ground/matilda.htm>, accessed May 15, 2010.

²³⁷ Ibid.

B.5.2. UGV Medium

B.5.2.1. *Metal Storm*

UGV can be used for anything from surveillance, EOD bomb detection and disposal, to combat operations. The US Navy could make use of UGV for EOD and surveillance. Other organizations can make use of UGV for surveillance, re-supply, and even combat integrated with manned forces in the field. One example is the Talon UGV, as shown in [Figure 137.](#), manufactured by Metal Storm.²³⁸



Figure 137. Metal Storm Talon UGV²³⁹

UGVs have not received a lot of the spotlight in recent years because there have not been a lot of breakthroughs in the area of artificial intelligence to handling the amount of obstacles for operations on the ground. In the following section four categories of UGVs have been examined and presently in use throughout the military.

²³⁸ Talon UGV, available from <http://www.metalstorm.com/> and <http://www.globalsecurity.org/military/systems/ground/talon.htm> , accessed January 10, 2010.

²³⁹ Talon UGV, <http://www.engadget.com/2005/03/30/metal-storms-talon-ugv-grenade-launcher/>, accessed January 10, 2010.

B.5.2.2. Remote Detection, Challenge, and Response System (REDCAR) (ARFL)



Figure 138. ARFL Remote Detection, Challenge, and Response System (REDCAR)²⁴⁰

Habitat: The REDCAR program, as shown in [Figure 138](#), focuses on the application of mobile unmanned ground systems to support and augment security force personnel in the perimeter defense of Air Force installations and forward deployed units.

Behavior: The AFRL REDCAR system will consist of a network of robotic platforms integrated with existing security force sensors and Tactical, Area Security System (TASS). The REDCAR system will have limited simulation and modeling capabilities to interact with the current AFFPB modeling systems. All components and platforms in the REDCAR system will be capable of communication using JAUS for system interoperability and control.

Notable Features: REDCAR will use at least three different robotic platforms:

²⁴⁰ REDCAR, <http://www.globalsecurity.org/military/systems/ground/redcar.htm>, accessed May 15, 2010.

- Surveillance platform
- Engagement platform
- Small-scale platform for limited access areas.²⁴¹

B.5.2.3. *Gladiator Tactical Unmanned Ground Vehicle*



Figure 139. Gladiator²⁴²

Habitat: Battlefield, multi-terrain vehicle

Behavior: Gladiator, as shown in [Figure 139](#), will perform scout/surveillance, nuclear biological and chemical reconnaissance, direct fire, and personnel obstacle breaching missions in its basic configuration.

²⁴¹ Ibid.

²⁴² Gladiator, <http://www.globalsecurity.org/military/systems/ground/gladiator.htm> , accessed May 15, 2010.

Notable Features: Essential Functions of the Gladiator system include:²⁴³

- Day/night remote visual acuity equal to that of an individual Marine using current image intensifying or thermal devices
- Battlefield mobility capable of supporting dismounted units in all environments, including MOUT rubble
- Modular design and incorporation of standard interfaces for attachment of future mission payloads
- Remain operable and mission capable after being impacted by multiple 7.62mm small arms rounds at zero standoff distance

B.5.2.4. Mobile Detection Assessment and Response System (MDARS)



Figure 140. Mobile Detection Assessment and Response System (MDARS)²⁴⁴

²⁴³ Ibid.

²⁴⁴ MDARS, <http://www.globalsecurity.org/military/systems/ground/mdars.htm>, accessed May 15, 2010.

Habitat: indoor and outdoor storage facilities

Behavior: The Mobile Detection Assessment and Response System (MDARS), as shown in [Figure 140](#), is a joint Army-Navy development effort to provide an automated intrusion detection and inventory assessment capability for use in DoD warehouses and storage sites. The MDARS goal is to provide multiple mobile platforms that perform random patrols within assigned areas of warehouses and storage sites.²⁴⁵

Notable Features: Very compact movement and can return to a charging station autonomously.

B.5.2.5. Remote Ordnance Neutralization System (RONS)



Figure 141. Remote Ordnance Neutralization System (RONS)²⁴⁶

²⁴⁵ Ibid.

²⁴⁶ RONS, <http://www.globalsecurity.org/military/systems/ground/mdars.htm>, accessed May 15, 2010.

Habitat: Remote Ordnance Neutralization System (RONS), as shown in [Figure 141](#), is primarily used in urban environments with versions for tougher terrain being currently designed.

Behavior: The Remote Ordnance Neutralization System provides each Explosive Ordnance Disposal (EOD) Team with a peacetime/wartime remote, standoff capability to perform EOD missions such as reconnaissance, access to site, remote render-safe procedure, “pick-up and carry away” (PUCA) and disposal tasks in a high-risk and/or contaminated environment.

Notable Features: A complete RONS consists of a remote-controlled platform and an operator control system, linked by either fiber optic or RF link.²⁴⁷

B.5.3. UGV Heavy

B.5.3.1. CAT (Crew-integration and Automation Test-bed)



Figure 142. Crew-integration and Automation Test-bed (CAT)²⁴⁸

²⁴⁷ Ibid.

Habitat: Wide spectrum of terrain can be covered on the battlefield, mobility of a tank or transport vehicle.

Behavior: The goal of the Crew-integration and Automation Test bed (CAT), as shown in [Figure 142.](#), Advanced Technology Demonstration (ATD) is to demonstrate a multi-mission capable two-man crew station platform concept, which will be integrated into a C-130 transportable chassis supporting the Army's objective force. This program focuses on an improved soldier machine interface (SMI) design using indirect vision driving and automated decision aids, an advanced electronic architecture design/network topology, and embedded simulation. By demonstrating these advanced technologies and added capabilities, the CAT ATD will prove out technology readiness to sufficiently transition and integrate hardware and software components into the Future Combat Systems (FCS) demonstrator.

Notable Features: Key Program Objectives:

- Design an advanced 2-man crew station for a system < 20 tons incorporating the FCS fight, carrier, reconnaissance, and C2 of unmanned systems
- Provide technology readiness sufficient to enable integration into future FCS system demonstrator
 - Soldier Machine Interface technology
 - Indirect Vision
 - Speech Recognition
 - Crewman's Associate Interface
 - Helmet Mounted Display vs. Panoramic Displays
 - Decision Aids (Route Planning, Driving, Mission, etc...)
- Embedded simulation while on-the-move
- Advanced vehicle architecture
- Prove out technology developments using a FCS class chassis to test against our exit criteria

²⁴⁸ CATS, <http://www.globalsecurity.org/military/systems/ground/cat.htm>, accessed May 15, 2010.

Technologies to be investigated include both traditional Soldier-Machine Interface (SMI) technologies (e.g., helmet-mounted displays, head trackers, panoramic displays, speech recognition, etc.) and robotics technologies (e.g., intelligent driving decision aids, semi-autonomous driving, automated route planning, etc.). Workload analysis performed under the CAT program indicates that the driving aids and automation technologies are key to achieving two-person operation of future systems. The crew stations and technologies were integrated into an IAV and demonstrated over fight, scout and carrier mission scenarios in FY03 and in FY04.²⁴⁹

B.5.3.2. Cooperative Unmanned Ground Attack Robots (COUGAR)



Figure 143. Cooperative Unmanned Ground Attack Robots (COUGAR)²⁵⁰

²⁴⁹ Ibid.

²⁵⁰ COUGAR, <http://www.globalsecurity.org/military/systems/ground/cougar.htm>, accessed May 15, 2010.

Habitat: Wide spectrum of terrain can be covered on the battlefield, mobility of a tank or transport vehicle.

Behavior: The Cooperative Unmanned Ground Attack Robots (COUGAR), shown in [Figure 143.](#), is a technology effort to investigate and demonstrate multiple unmanned systems cooperating for the purpose of delivering lethal fires. As such, the COUGAR is not a system, but a lethal capability that could transition into a variety of unmanned system programs including the FCS and Gladiator.

Notable Features: Phase I of the COUGAR project was completed in FY01. During Phase I, a XUV based robot with a RSTA package and a Javelin missile were simulated. A demonstration of the Phase I system was completed with the successful launch of both 19 Light Antitank Weapon (LAW) rockets and 1 Javelin missile. Phase II of the COUGAR is currently under way.

The COUGAR Phase II demonstration system is composed of a command vehicle that will host the Operator Control Unit and a single operator. The Killer Robot will be a XUV-based robot that will carry HELLFIRE missiles. The Hunter Robot will be a XUV-based robot that will carry a day/night reconnaissance payload, a laser designation system, and an organic Unmanned Air Vehicle (UAV). The organic UAV will be the Compact Air Vehicle – Shooter Linker (CAV-SL) being developed under an Army Aviation and Missile Command 6.2 program. Before launch, the operator programs the CAV-SL's flight path.

COUGAR is an outgrowth of an Aviation and Missile Research, Development, and Engineering Center (AMRDEC) 6.2 program called Robotic Applications for Modular Payloads (RAMP). RAMP was a technology project designed to investigate technologies that support dynamic plug-and-play payloads. The warfighter is then able to reconfigure a robotic system for a different mission simply by swapping payloads. The robotic systems will identify the payload and configure the OCU to support that payload.²⁵¹

²⁵¹ Ibid.

B.5.4. UGV Large

B.5.4.1. Automated Ordnance Excavator (AOE)

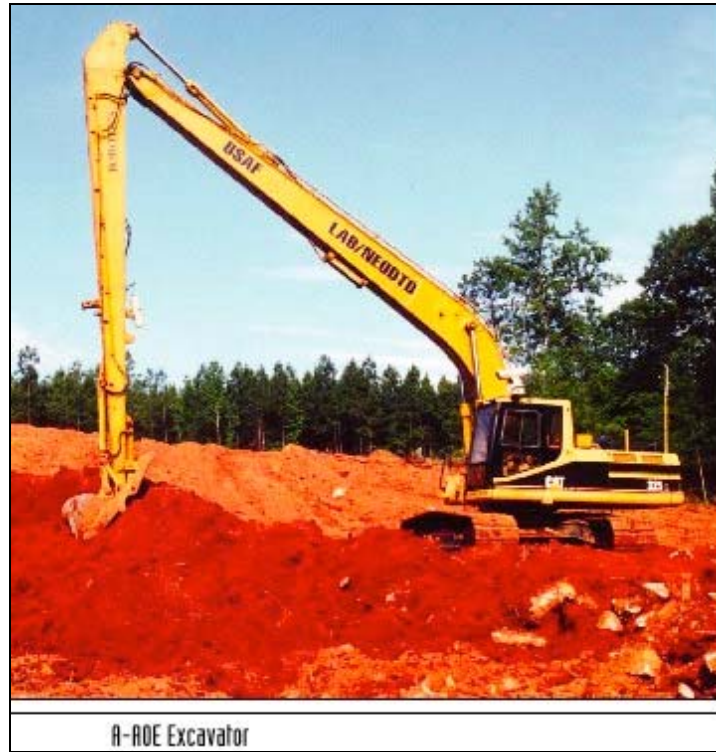

Figure 144. Automated Ordnance Excavator (AOE)²⁵²

Habitat: Utilized to clear out mine fields and ranges.

Behavior: The command and control system used for ARTS was expanded to robotically operate the Automated Ordnance Excavator (AOE). The AOE, shown in [Figure 144.](#), is a Caterpillar excavator that can be used to robotically excavate buried ordnance and remove it to a safe place for disposal. The first prototype system is being used by the Army Corp of Engineers to clear an old impact area at Camp Croft in Pacolet, SC.

Notable Features: The ARTS provides Air Force security forces with a system to combat terrorist threats. At Nellis AFB, EOD personnel continue to use ARTS for range clearance of dangerous unexploded ordnance.²⁵³

²⁵² AOE, <http://www.globalsecurity.org/military/systems/ground/aoe.htm>, accessed May 15, 2010.

B.5.4.2. CRUSHER



Figure 145. CRUSHER²⁵⁴

Habitat: Wide spectrum of terrain can be covered on the battlefield, mobility of a tank or transport vehicle. Rough terrain is its specialty.

Behavior: The 6.5-ton "Crusher", shown in [Figure 145](#), combines the strength and mobility of a predecessor known as Spinner with NREC-developed autonomy capabilities to create an extremely robust, unmanned vehicle that can function on its own in challenging off-road terrain.²⁵⁵

Notable Features: Currently still being tested, by its inventing team at Carnegie Mellon University's National Robotics Engineering Center (NREC) in the School of Computer Science's Robotics Institute.

²⁵³ Ibid.

²⁵⁴ Crusher, <http://www.physorg.com/news65522328.html>, accessed May 15, 2010.

²⁵⁵ Ibid.

B.6. UNMANNED OUTER SPACE VEHICLES

B.6.1. Space X-37B (Boeing)

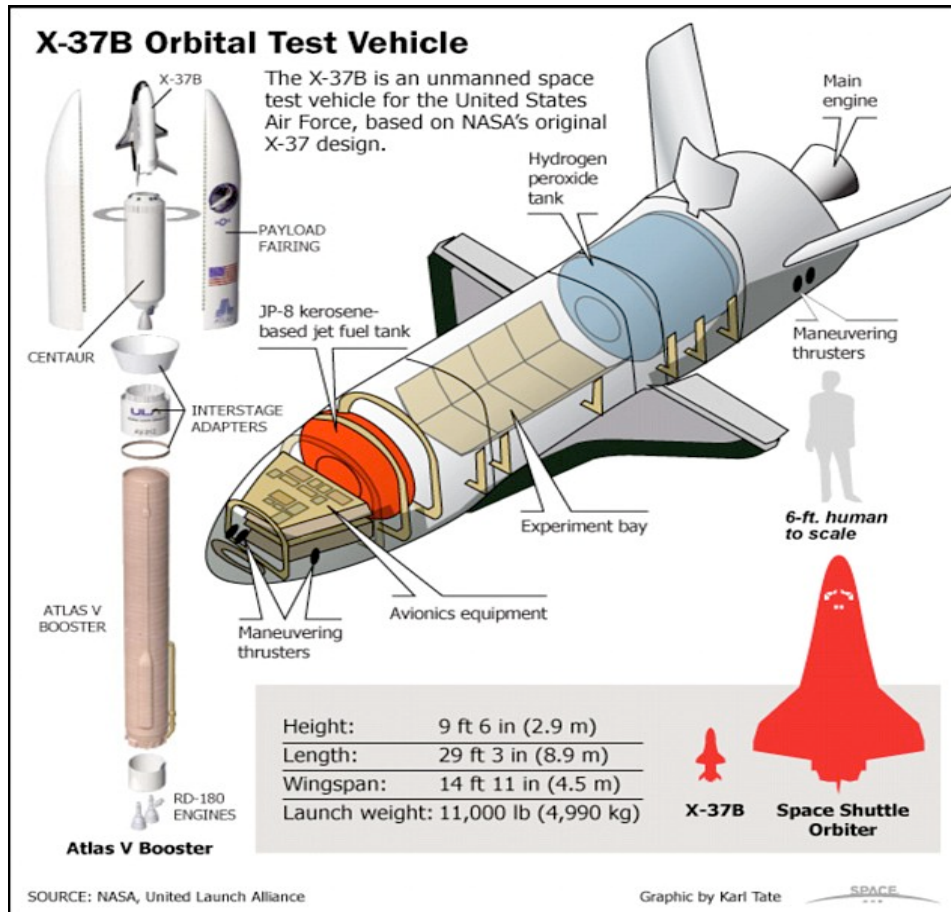

Figure 146. Boeing X-37B²⁵⁶

²⁵⁶ X-37B,



Figure 147. Boeing X-37B²⁵⁷

Habitat: Earth's orbit, space.

Behavior: It is powered by a solar cells and lithium-ion batteries, unlike a traditional craft which is powered by a fuel cell system. It has a large engine at the rear for orbit changing. The space plane is also reusable.

Notable Features: The X-37B, shown in [Figure 146.](#) and [Figure 147.](#), is 9m long (29ft) and has a wingspan of 4.5m (15ft), making it a quarter of the size of a normal Shuttle.

Built by Boeing's Phantom Works division, the X-37 program was originally headed by NASA. It was later handed over to the Pentagon's research and development arm and then to a secretive Air Force unit.²⁵⁸

Airforce Official Site²⁵⁹

²⁵⁷ X-37B, Daily Mail "Unmanned Space Shuttle Launched"
<http://www.dailymail.co.uk/news/worldnews/article-1268138/X-37B-unmanned-space-shuttle-launched-tonight.html>, accessed May 15, 2010.

²⁵⁸ Ibid.

²⁵⁹ X-37B, <http://www.af.mil/news/story.asp?storyID=123032226> accessed May 15, 2010.

THIS PAGE INTENTIONALLY LEFT BLANK

INITIAL DISTRIBUTION LIST

1. Defense Technical Information Center
Ft. Belvoir, Virginia
2. Dudley Knox Library
Naval Postgraduate School
Monterey, California
3. Navy Expeditionary Combat Command (NECC)
1575 Gator Blvd
Virginia Beach, VA 23459
4. Mr. Charles Werchado
Chief of Naval Operations
2000 Navy Pentagon N8FB
Washington, DC 20350-2000
5. Mr. James McCarthy
Chief of Naval Operations
2000 Navy Pentagon N8B
Washington, DC 20350-2000

THIS PAGE INTENTIONALLY LEFT BLANK