



Calhoun: The NPS Institutional Archive
DSpace Repository

CRUSER (Consortium for Robotics and Unmanned Systems Education and Research) Faculty and Researchers' Publications

2018

Study of Cybersecurity Requirements for the Military Robot Operating System (ROS-M) using ROS 2.0 on Unmanned Aerial Networks

Thulasiraman, Preetha

Monterey, California: Naval Postgraduate School

<https://hdl.handle.net/10945/58143>

This publication is a work of the U.S. Government as defined in Title 17, United States Code, Section 101. Copyright protection is not available for this work in the United States.

Downloaded from NPS Archive: Calhoun



Calhoun is the Naval Postgraduate School's public access digital repository for research materials and institutional publications created by the NPS community. Calhoun is named for Professor of Mathematics Guy K. Calhoun, NPS's first appointed -- and published -- scholarly author.

Dudley Knox Library / Naval Postgraduate School
411 Dyer Road / 1 University Circle
Monterey, California USA 93943

<http://www.nps.edu/library>

Study of Cybersecurity Requirements for the Military Robot Operating System (ROS-M) using ROS 2.0 on Unmanned Aerial Networks

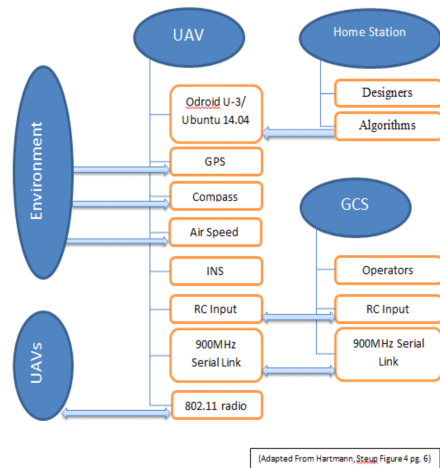
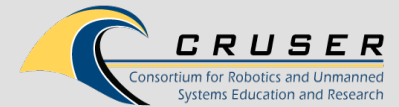

How

- 1) Begin with studying ROS-M cybersecurity requirements; Understand ROS-M technical scope, particularly ROS 2.0
- 2) ROS-M Cybersecurity Framework
 - Build PKI on the ROS-M environment using techniques specified by SROS and ROS 2.0
 - Study management of public and private keys for PKI and how to securely disseminate keys among different ROS-M nodes
 - Evaluate the ROS-M PKI via simulations of small UAV networks using the Gazebo simulation platform
 - Evaluate how ROS-M cybersecurity mitigates different threat models

Representation of the UAV

What/Deliverables

- Manage cybersecurity risk, such that near term capabilities for systems autonomy can be achieved
- Assessment of the military security standards associated for open source software and determine if such security practices can be implemented for ROS-M using Secure ROS (SROS)/ROS 2.0 as proposed by OSRF
- Study cybersecurity primitives in the ROS-M environment (public key infrastructure (PKI), key management for PKI and securing wireless channel through secure handshake) based on SROS and ROS 2.0
- Analysis of exploitation avenues for ROS-M on small aerial networks
- This is a continuation of work executed in FY17 in which security for the standard ROS 1.0 platform was investigated

Why/Objective

- DoD is seeking to build a military centric ROS
- Implementation of ROS-M and ROS 2.0 is currently in its development phase
- Adoption of one operating framework (ROS-M) would lead to cost savings in program development cycles as well as an increase in reliability and operability
- Ability to securely control ROS-M enabled platforms free from adversarial interference is of the utmost importance.
- The proposed research is operationally relevant and will contribute to relevant thesis study for NPS students
- Cybersecurity is an important research and curricular component at NPS and thus furthers the mission of the school, Navy and DoD.



FY18 Call for Proposals

Dr. Preetha Thulasiraman, Associate Professor
 Department of Electrical and Computer Engineering
pthulas1@nps.edu, Office Ph: 831-656-3456