



Calhoun: The NPS Institutional Archive
DSpace Repository

NPS Scholarship

Theses

1971-09

A study of the effect of the ion exchange method of chemical tempering on a macroflaw in soda-lime glass.

Liedmandt, Michael Jerome

Monterey, California. Naval Postgraduate School

<https://hdl.handle.net/10945/15918>

This publication is a work of the U.S. Government as defined in Title 17, United States Code, Section 101. Copyright protection is not available for this work in the United States.

Downloaded from NPS Archive: Calhoun



Calhoun is the Naval Postgraduate School's public access digital repository for research materials and institutional publications created by the NPS community. Calhoun is named for Professor of Mathematics Guy K. Calhoun, NPS's first appointed -- and published -- scholarly author.

Dudley Knox Library / Naval Postgraduate School
411 Dyer Road / 1 University Circle
Monterey, California USA 93943

<http://www.nps.edu/library>

A STUDY OF THE EFFECT OF THE ION
EXCHANGE METHOD OF CHEMICAL
TEMPERING ON A MACROFLAW IN
SODA-LIME GLASS

by

Michael Jerome Liemandt

United States
Naval Postgraduate School



THE SIS

A STUDY OF THE EFFECT OF THE ION EXCHANGE
METHOD OF CHEMICAL TEMPERING ON A MACROFLAW
IN SODA-LIME GLASS

by

Michael Jerome Liemandt

Thesis Advisor:

R. B. Leonesio

September 1971

Approved for public release; distribution unlimited.

A Study of the Effect of the Ion Exchange Method
of
Chemical Tempering on a Macroflaw in Soda-Lime Glass

by

Michaël Jerome Liemandt
Lieutenant, United States Navy
B.S., United States Naval Academy, 1964 -

Submitted in partial fulfillment of the
requirements for the degree of

MASTER OF SCIENCE IN OCEANOGRAPHY

from the

NAVAL POSTGRADUATE SCHOOL
September 1971

1700
L 638
C. 1

ABSTRACT

In recent years much research has gone into determining the behavior of glass which makes it adaptable for structural use in submersible vehicles and for oceanographic instrumentation packages. This work examines the strengthening effect of the ion exchange method of chemical tempering on a macroflaw in glass. Use of a macroflaw allows a quantitative fracture mechanics analysis of the amount of strengthening. Precracked soda-lime glass specimens were treated for various lengths of time in a potassium nitrate salt bath held at 365°C. The behavior of the macroflaw while being treated and at fracture was closely observed. The strain energy release rate, G_c , and the fracture toughness, K_c , were found by using the double cantilever cleavage technique of measuring fracture surface energies. The average strengthening which occurred at this temperature was found to be almost linear with time with a maximum increase of G_c of approximately 300 per cent at twenty-four hours. The diffusion of ions was determined to be inward from the sides of the flaw rather than across the entire flaw tip.

TABLE OF CONTENTS

I.	INTRODUCTION -----	7
II.	PROPERTIES AND BEHAVIOR OF GLASS -----	8
III.	ION EXCHANGE STRENGTHENING -----	13
IV.	FRACTURE MECHANICS ANALYSIS -----	17
V.	EXPERIMENTAL PROCEDURE -----	22
VI.	RESULTS AND DISCUSSION -----	29
	A. SPECIMENS USED -----	29
	B. DISCUSSION OF SPECIMEN BEHAVIOR -----	29
	C. DATA -----	39
	D. DATA ANALYSIS -----	49
VII.	RECOMMENDED FURTHER STUDIES -----	62
VIII.	CONCLUSIONS -----	64
	APPENDIX A: SPECIMEN PRECRACKING PROCEDURE -----	65
	LIST OF REFERENCES -----	68
	INITIAL DISTRIBUTION LIST -----	70
	FORM DD 1473 -----	71

LIST OF TABLES

I.	Composition and Characteristics of the Glass Used -----	23
II.	Average G_C and K_C for all Specimens with Standard Deviations -----	41
III.	Maximum G_C and K_C for all Specimens -----	42
IV.	Fracture Surface Energies of Soda-Lime Glass, Other Studies -----	51

LIST OF FIGURES

1.	Pauling's Ionic Diameters -----	14
2.	Gilman's Sample Configuration -----	20
3.	Specimen Configuration -----	21
4.	Precracking Fixture -----	24
5a.	Specimen Suspension -----	26
5b.	Salt Bath Equipment -----	26
6.	Loading Fixture on Instron Machine -----	27
7.	Crack Behavior -----	30
8.	Crack Behavior -----	33
9.	Stresses in a Specimen Caused by Solidified Salt ---	35
10.	Stresses in a Specimen Caused by C-clamp Application -----	35
11.	Fracture Behavior -----	38
12.	Fracture Behavior -----	38
13.	Load vs. Displacement Curve -----	40
14.	G_c vs. Treatment Time Plot of all Uncoated Specimens -----	43
15.	G_c vs. Treatment Time Plot of all Coated Specimens -	44
16.	Average G_c with Standard Deviations vs. Treatment Time up to 24 Hours -----	46
17.	Maximum G_c vs. Treatment Time Up to 24 Hours -----	47
18.	Average G_c vs. Treatment Time for Long Time Specimens vs. Projected Averages -----	48
19.	Maximum G_c vs. Treatment Time for Long Time Specimens vs. Projected Maxima -----	50
20.	Increase of Compressive Stresses with Time -----	54
21.	Increase of Compressive Stresses with Time -----	54
22.	Stresses Caused by Salt Solidified in Cracks of Specimens Treated for 24 Hours -----	55

I. INTRODUCTION

In the past decade the use of glass as a structural material for underwater use has claimed a great deal of attention. The fact that massive glass appears to be strengthened by the high pressures at ocean depths rather than weakened as metals are can account for much of this attention [1]. The transparency of glass is another recommendation for its use both as manned observation submersibles and as capsulation for oceanographic instrumentation with resulting observational ease. Other recommendations for its use are its hardness, relative low cost and ease of forming. The major disadvantage is its brittleness and phenomenon of delayed fracture. For these reasons a considerable amount of work has been expended in the study of glass and methods of improving its characteristics. This paper investigates the effect of one method of strengthening glass on a macroscopic flaw. The nature and behavior of glass is discussed briefly followed by a description of a method of chemical tempering. A fracture mechanics approach describing the mode of failure is used to study the strengthening effect on glass.

II. PROPERTIES AND BEHAVIOR OF GLASS

Glass is unlike crystalline materials in that it contains no long range order. This has been shown by x-ray diffraction methods which demonstrate only broad spectrum patterns [2]. This glassy or vitreous state is brought about by cooling a liquid rapidly enough to prevent crystallization. It is a state which is intermediate between that of a usual solid, exhibiting rigidity, and the random structure of a liquid. Most industrial glasses are based on the material silica SiO_2 which exists in several crystalline forms [3]. Again from x-ray diffraction analysis it is shown that silica glasses are characterized by a random distribution of SiO_4 tetrahedra, each of which are interlocking in that each oxygen atom is shared by two adjacent tetrahedra. That is, covalent bonding exists with each Si^{++++} sharing electrons with 4 O^{--} and each of the 4 oxygen ions sharing electrons with 2 silicon ions. These ions tend to conserve a specific ionic radii. Tables of these radii have been made by Pauling [4] which show that Si^{++++} has a radius of 0.41 compared to O^{--} radius of 1.40. Thus each tetrahedra consists of a small Si^{++++} ion surrounded by large O^{--} ions. When glass is formed with the usual oxide additives such as Na_2O , Al_2O_3 , etc., an excess of oxygen ions occurs so that not all O^{--} ions are shared by two Si^{++++} ions. This creates spaces or areas of less bonding allowing the presence of the monovalent metallic and alkalide ions. These monovalent ions represent points of mechanical weaknesses in the material

because of the weak bonding and lower potential barriers resisting their diffusion. Thus glasses are composed of a random network of interlocking SiO_4 tetrahedra with divalent metallic and monovalent alkali ions interspersed throughout in a random nature.

Glasses show an interesting behavior in the transformation range of temperatures (400 to 600°C). This temperature range is defined as that above which the rate of internal structural changes is great enough so that the structure is in a state of equilibrium with the temperature. Below this temperature rates of structural change are so slow as to be negligible. That is, the structure may be considered to be unchanged with time regardless of warming or cooling or mechanical or electrical stresses. The specific temperature at which this transformation takes place is known as the fictive temperature. This temperature is dependent on glass composition and temperature history but the important thing here is that it does occur at some point for all glasses [5].

When a glass cools from its melt each monovalent ion is encased in a network which conforms to its ionic shape and diameter until the fictive temperature is reached. At this temperature the internal structure is "locked" and remains constant with further cooling. Any further diffusion of ions is over high potential barriers. Electroneutrality requires that any cavity which is formed by diffusion of such an ion must be quickly filled by another ion undergoing diffusion.

Glass behaves as a brittle material during loading. It follows Hooke's Law during loading as far as failure. This brittle nature results because only a very small amount of plastic deformation takes place during failure. The length of the plastic zone is on the order of the atomic bonding distance in the glass. Some investigators have claimed that deformation of glass by hardness tests indicates plastic deformation [6]; however, this deformation has not been observed in normal tension, compression or bending tests. Testing shows glass to be elastic and to have no yield stress [7].

With the exception of very special tests, glass failure always occurs in a tensile mode of loading [8]. Even when loaded in compression some irregularity in structural shape or load application will cause tensile load components to be induced and it is at these points that failure occurs. One of the first things noticeable when tests are conducted is that failure strengths vary considerably from sample to sample even when the samples are of the same dimensions and shape and of identical composition glass. The first explanation of this variation in strengths and the difference in observed and theoretical strengths of glass was explained by Griffith in 1920 [9]. He showed that surface flaws are the cause of the reduction and variation in strengths. Any flaw present causes an extremely high concentration of stresses at the tip of the flaw and the strength of a sample varies with the size and shape of these surface flaws. The size of

these flaws was surprising in that they can be so small as to be unobservable even by microscopic methods. Even touching pristine glass was found to drastically reduce its strength. Thermal shocks as well as mechanical damage can cause flaws which effect the actual strength of any glass. Other factors affecting observed strengths include the rate and type of loading involved and the temperature and medium in which the test is carried out [8].

Several methods of overcoming these flaws to increase the strength of glass have been developed ranging from removal of the damaged layer to methods of protecting the surface. One strengthening procedure developed is that of producing a compressive stress in the surface layer of the glass. This compressive stress must then be overcome before a tensile stress can effect any surface flaws. Several means of producing this surface compressive stress have been used. The oldest is that of thermal tempering. In simple terms, the glass is cooled so rapidly from above its softening temperature that a temperature gradient arises between the core and the surface of the specimen. As the glass now cools past its fictive temperature the surface ions are locked in place prior to those in the center. Thus, the center continues to contract placing the core in tension. This inner tension in turn causes a resultant surface compressive stress. Since this method produces a relatively deep compressive layer it is useable only for fairly thick specimens which allow strong temperature gradients. Also, oddly shaped

pieces when tempered can produce varying compressive stresses which can be worse than no layer. A second method is to coat the surface with another type of glass with a lower coefficient of expansion while the specimen is still being shaped. Still another method involves the creation of a layer with a low coefficient of expansion by crystallization. A final method of producing surface compression is by ion exchange at the surface. This last method was the one picked as most convenient for this experiment and will be discussed in more detail.

III. ION EXCHANGE STRENGTHENING

The method of ion exchange strengthening is dependent upon a diffusion process caused by a concentration gradient between different ions in adjoining viscous materials. When a solution of monovalent ions is in contact with glass, a vitreous or rigid liquid, such a concentration gradient exists. If these monovalent ions are larger than those normally occurring in the glass and if the diffusion is taking place below the fictive temperature where the glass network was "locked" in place then any diffusion of these ions into spaces originally occupied by those smaller ions will cause a stretching of the glass ionic network to accommodate them. This stretching results in a compressive stress field at the surface of the glass and is thus "ion exchange strengthening."

Since ion exchange is a process of diffusion it is dependent upon the temperature, the time length of treatment and the relative concentrations of the ions in question. It is dependent upon temperature since the motion of ions is thermally activated. The higher the temperature the faster the ions receive the necessary energy for motion. However, the amount of exchange taking place at any one temperature is time dependent. As the surface layer of ions reaches equilibrium in concentrations, the exchange must now move within the glass itself. Theoretically the process is an infinitely long one, but in a measureable length of

time it slows to a point that for practical purposes may be considered to be in equilibrium. A major reason for this is that at high temperatures over very long time periods stress relaxations will take place and nullify further strengthening. The process will also slow as the replacement ion solution becomes low in replacement ions and high in concentration of the replaced ions. That is, the solution must be kept fresh to be effective. The diffusion process can be quite sufficiently agitated thermally at temperatures below the fictive temperature and it should be carried out sufficiently below the fictive temperature so that the compressive stress which is built up is not relaxed [8].

The ions in question for this experiment are the Na^+ ions of the glass and the K^+ ions of a salt melt. Paulings' calculated diameters for these two ions are shown in Figure 1 [4]. These sizes yield the fact that the K^+ ion is forty percent greater in diameter and comprises a volume 2.75 times

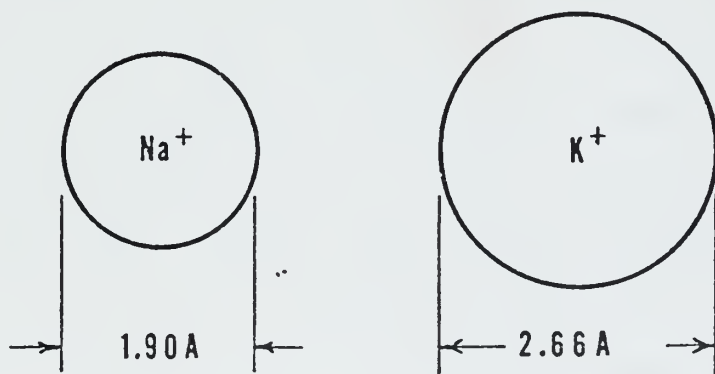

Figure 1. Pauling's calculated ionic diameters for sodium and potassium.

that of the Na^+ ion in the glass. So if a K^+ ion does take the place of a Na^+ ion in the glass network there must obviously be a considerable packing effect and resultant compressive stresses. A graphic example of the stresses this method is capable of forming is, that if a KNO_3 salt is melted in either a glass beaker or porcelain crucible and held there for some hours, the container will burst because of the strong compression built up on its interior surface [10]. These stresses have been experimentally demonstrated and measured by the elastic distortion of glass disks treated on only one side. It was found that ion exchange can increase the strength of glass by a factor of three [10]. However, this strength increase is only for a particular glass held in a diffusive environment at a particular temperature for a certain length of time. Strengthening was also found to remain, although to a lesser extent, after abrasion [11]. This is probably because the abrasion applied did not penetrate the surface compression layer.

The amount of diffusion and resulting surface compressive stresses have been found to vary considerably with the composition of the glass being tested. Some constituents seem to retard diffusion while others tend to increase the effect. This also depends upon the ion intended to replace the ions of the glass. Different alkalides can be used in replacing different ions. For instance NaNO_3 may be used as a salt and the Na^+ ions used to replace smaller Li^+ ions in lithium glass or as in the case of this experiment KNO_3

may be used as a salt with the K^+ replacing the Na^+ ions of a soda glass. The process can also work in reverse. If a lithium salt is used on a soda glass the replacement ions are smaller and a surface tension will be introduced causing countless surface cracks and a considerable weakening effect [8].

A great many studies have been carried out with chemically tempered glass proving increases in strength due to the compressive layer. These tests in general treated glass rod or plate and then tested the treated specimen through the elastic limit to failure. The improvement of strength has been attributed to the compressive layer reaching a sufficient depth to counteract the Griffith type surface microflaw or a sufficient depth to resist some standard surface abrasion after the treatment. This paper has applied the same reasoning not to microflaws and the more or less statistical presence of a flaw, but to a large macroflaw so that a fracture mechanics analysis could be employed. This allowed the ion exchange method of strengthening effect on a specific flaw and the resultant quantitative increase of strength of that specific flaw to be examined.

IV. FRACTURE MECHANICS ANALYSIS

Fracture mechanics can be applied quite successfully to materials such as glass. In application of fracture mechanics it is assumed that all structures have some flaw or crack present and that failure occurs by propagation of the largest such flaw present [12]. This is quite similar to the Griffith theory of failure; that brittle bodies fail because of the extreme narrowness of flaws present which cause high stress concentrations at their tips. The fracture mechanics application is based on G. R. Irwin's definition that the magnitude of the stress field at a crack tip may be expressed in terms of a single parameter K , defined as the stress intensity factor. This parameter K is a function of the applied load and crack dimensions which increases with increasing load and crack size. When the applied load produces a critical stress field at the crack tip, the crack propagates rapidly and a failure occurs. At this point K equals K_c at the critical stress intensity. This value of K_c defines the term fracture toughness. The fracture toughness is a constant for any given material since the failure is a function of the critical stress field at the crack tip. Formulations for K have been determined for many different test geometries [13]. The use of these formulations and such experimental analysis is not necessary, however, because of the relationship of K to Griffith theory

by another parameter G , the strain energy release rate [12].

The relationship is:

$$G = \frac{K^2}{E} (1-\nu^2) \quad \text{for plane strain 1(a)}$$

$$G = \frac{K^2}{E} \quad \text{for plane stress 1(b)}$$

where,

E = Young's modulus

ν = Poisson's ratio.

Physically G is a measure of the energy per unit area available for the crack-extension process. When K is equal to K_C then G is equal to G_C .

The critical strain energy release rate G_C can also be defined as the sum of the surface energy and the energy absorbed by plastic deformation at the crack tip.

$$G_C = 2\gamma + U \quad (2)$$

where,

γ = surface energy of the material. (Factor of two required because of the two surfaces of the crack generated)

U = plastic deformation energy.

When G is greater than this critical value, failure occurs.

As mentioned previously the size of the zone of plastic deformation at the crack tip in glass has been determined to be on the order of the size of the silicon-oxygen bond distance [7]. The resultant assumption is that the plastic zone

is quite small, therefore the plastic deformation energy U is quite small; this fact is the basic reason that a material is brittle. For this reason the second term of Equation (2) is generally assumed negligible in determinations of the strain energy release rate.

Because of the brittle nature of glass and the constraint imposed on the region of plastic flow at the crack tip, it was felt that the relationship between the strain energy release rate G_c and the fracture toughness, K_c , should be that of plain strain, Equation (1a).

One of the more easily applied techniques for measuring fracture surface energies of solids is by use of the double cantilever beam formulation of Gilman [14]. His sample configuration is shown in Figure 2. The uniqueness of this method is that to determine the fracture surface energy only the force necessary to propagate a crack of known size is needed besides the specimen dimensions. The modified equation of Gillis and Gilman [15] was refined by Wiederhorn, Shorb, and Moses [16] for use with Soda-Lime glass. Their equation matched closely one derived by Srawley and Gross [16] through a separate and different analysis. The constants were found to be essentially independent of the material used. This equation was determined to be valid for crack lengths greater than approximately 1.5 times t , the specimen half height. The resultant equation of the above studies is used in this paper with a modification to allow for the difference in specimen and crack dimensions caused

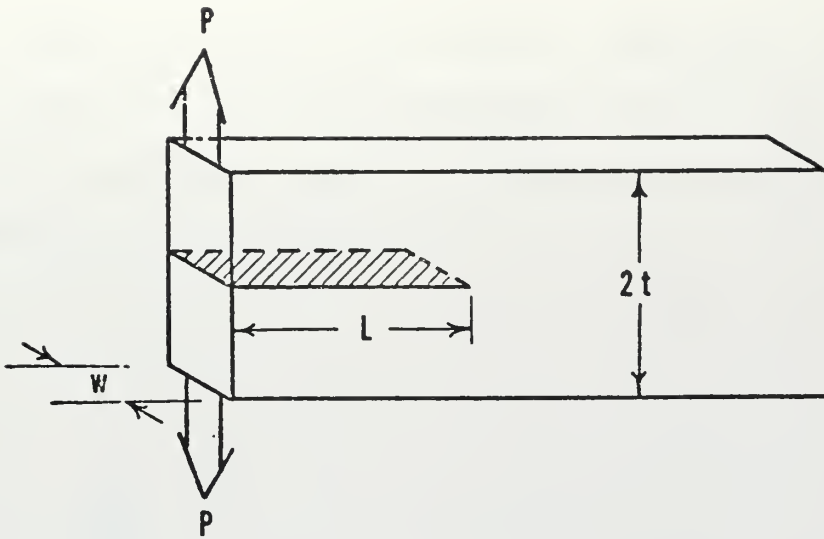

Figure 2. Gilman's sample configuration. P is the applied force, L is the crack length, and $2t$ and w are specimen dimensions.

by the use of side grooves for this work. The resultant equation used is Equation (3).

$$\gamma = \frac{6P^2L^2}{Ewb^3t^3} [1 + 1.34t/L + 0.45(t/L)^2] \quad (3)$$

where,

P , L , w , b , t are the load, crack length, and specimen dimensions respectively as shown in Figure 3.

E = Young's modulus.

It has been determined that temperature and environment of testing has a direct effect on the value of the fracture toughness [17, 18, 19]. This is of particular importance in the understanding of crack propagation by corrosion or fatigue loading. Therefore all data collected for this paper

was taken under the same environmental conditions. The load was also applied at a rate sufficiently fast so that any effect of the environment would be minimized and hopefully kept constant for all tests.

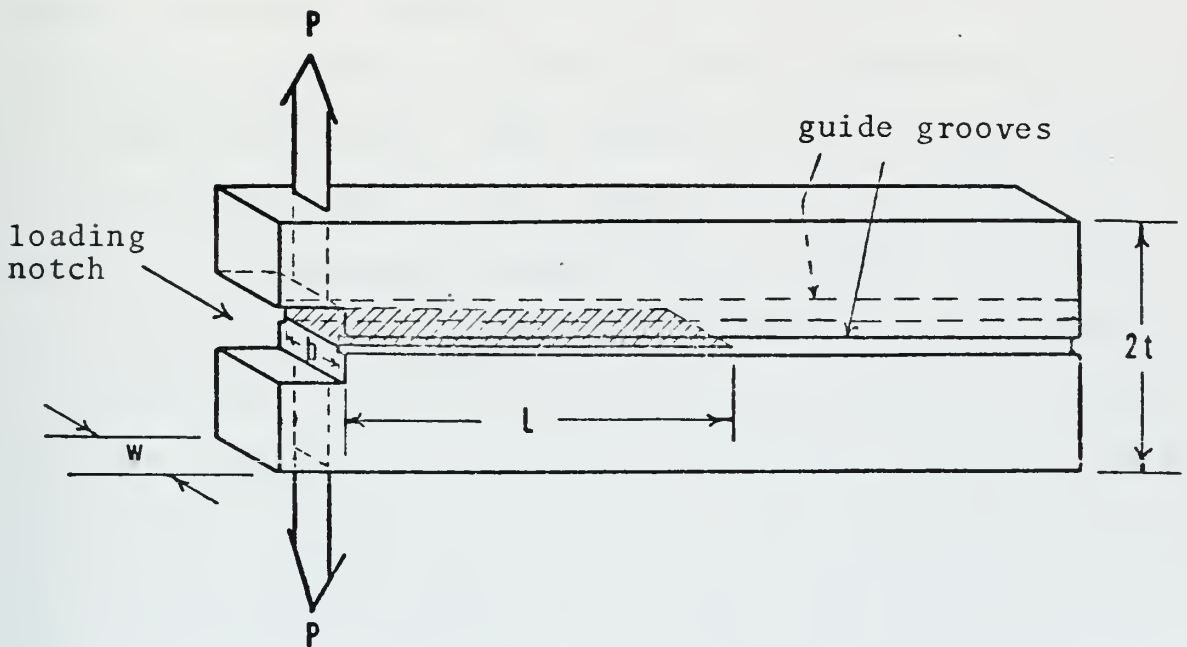

Figure 3. Specimen configuration. P is the applied force, L is the crack length, b is specimen thickness between grooves, $2t$ and w are outside dimensions. The crosshatched region indicates the crack surfaces.

V. EXPERIMENTAL PROCEDURE

The glass specimens used for all data points accumulated were taken from a soda-lime sheet glass of 3/16" thickness.¹ Its composition, elastic constants, and critical temperature points are shown in Table I. It was picked mainly because its composition allows sufficient ion exchange and also because it was available locally and was of a known composition. All specimens used were made from a single large sheet so that composition variation was a minimum. The specimen configuration was picked over others which might give more precise results because of its ease of manufacture. Because each specimen was tested at failure only one data point was obtainable from each specimen. This necessitated a simple configuration. This specimen type also has been used extensively by other investigators making results directly comparable. The specimen as used was slightly modified from that shown in Figure 2. The actual specimen used is shown in Figure 3. The only modifications are the centerline grooves on both sides and a loading notch at the open end instead of loading holes [20]. The specimens were cut to roughly three inch by one inch rectangles. The loading notch was then ground in one end to approximately 1/4" depth. The specimens were then grooved on both sides using

¹ PPG Industries Inc., Pennvernon ^(R) sheet glass. Information in Table I was obtained through correspondence with PPG Industries Inc.

Table I. Composition and Characteristics of the Glass Used

Glass 3/16" Soda-Lime Sheet	Composition (weight percent)						
	SiO ₂	Na ₂ O	CaO	MgO	Na ₂ SO ₄	Fe ₂ O ₃	Al ₂ O ₃
	73%	13.25%	8.2%	3.55%	0.21%	0.11%	1.2%
plus traces of NaCl and K ₂ O							
Young's Modulus							10 ⁷ psi
Poisson's Ratio							0.22
Strain Point Temperature							521°C
Annealing Temperature Range							516-575°C

a water cooled diamond saw. These grooves were cut to approximately .025" depth. The grooves were made to insure that the crack introduced would be centered in the specimen and parallel to the specimen sides to at least a close approximation. These grooves were .026" in width which did allow some wandering of the crack, but were determined to be the best method available to guide the precrack. They also were found to guide the crack quite well in the actual fracture process.

At this point in the specimen manufacture all specimens were annealed in a standard glassblowers oven. They were held in the manufacturers recommended annealing temperature range, approximately 525°C, for one half hour and allowed to cool to room temperature in twelve hours (slightly faster than 4°C per hour). This was done so that any small residual stresses after the initial glass manufacture or those induced in specimen manufacture would be removed. In this manner all specimens were standardized to a common starting point.

The crack was introduced using a point load applied by the fixture shown in Figure 4. Before loading, a scratch was introduced within the grooves near the loading notch with a diamond tip scribe. Normally the cracks introduced with the loading fixture were not perpendicular to the edges of the specimen. Therefore, they were extended to the desired position utilizing the heat gradient caused by a fine tip soldering iron [21]. It was determined by testing that this method did not leave residual thermal stresses of any appreciable amount. All crack lengths were between $2.5t$ and $3.0t$ in length, $2t$ being the specimen width dimension. Further discussion of the precracking procedure may

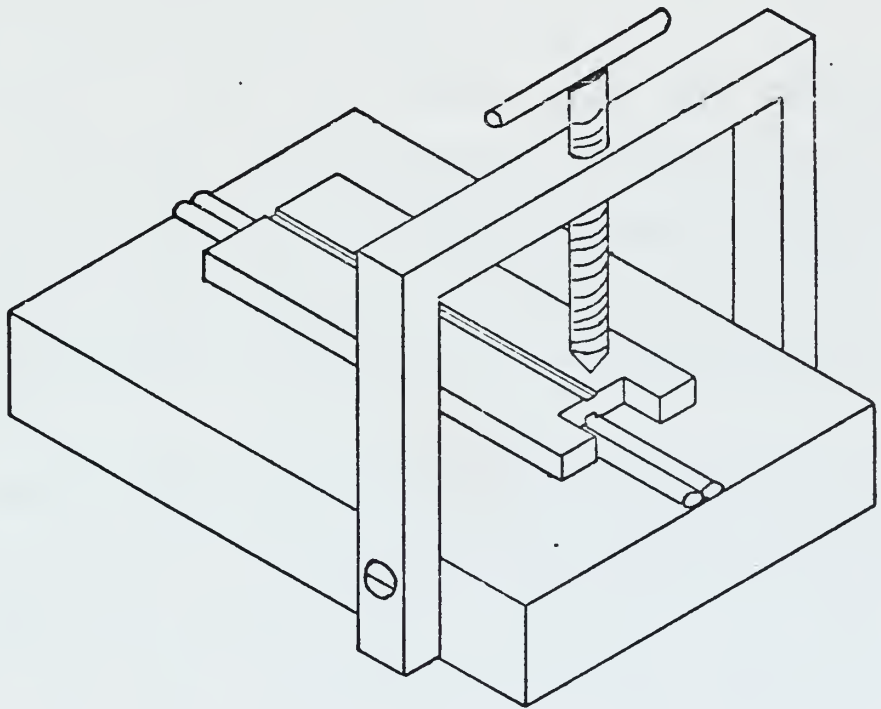

Figure 4. The fabricated specimen is shown in the fixture used to introduce the crack. A point load is applied by the turnbolt at the end of the specimen as shown. The specimen rests on two thin rods acting as fulcrums.

be found in Appendix A. Several specimens were fractured after the above fabrication to act as standards for the remainder of the experiment.

The treatment of the specimens consisted of immersing them in a KNO_3 salt bath held at $365^\circ\text{C} \pm 5^\circ\text{C}$ for varying lengths of time. This temperature was picked since it was, as recommended, [8] at least 100°C below the strain point of the glass and also was well below the listed decomposeure temperature (400°C) of the KNO_3 . All crack lengths were measured prior to submergence to be checked after removal for any extension or healing [22]. The specimens were suspended and immersed as shown in Figure 5. All specimens were lowered slowly through a warming compartment over a period of one hour so that the thermal shock upon submergence would not be too great. Approximately 40 minutes was allowed for step by step raising through the warming compartment at removal. This procedure was followed after the first few specimens were observed to have broken when they were removed.

Upon removal from the warming compartment the best procedure was to place a C-clamp across the specimen creating a slight compressive stress field at the crack tip, while the specimen was still at a temperature greater than 100°C . The specimens were then immersed in water until the salt which had solidified in the crack was completely dissolved. This procedure was introduced to prevent stress corrosion cracking of the specimen. This phenomenon is discussed in the section on results.

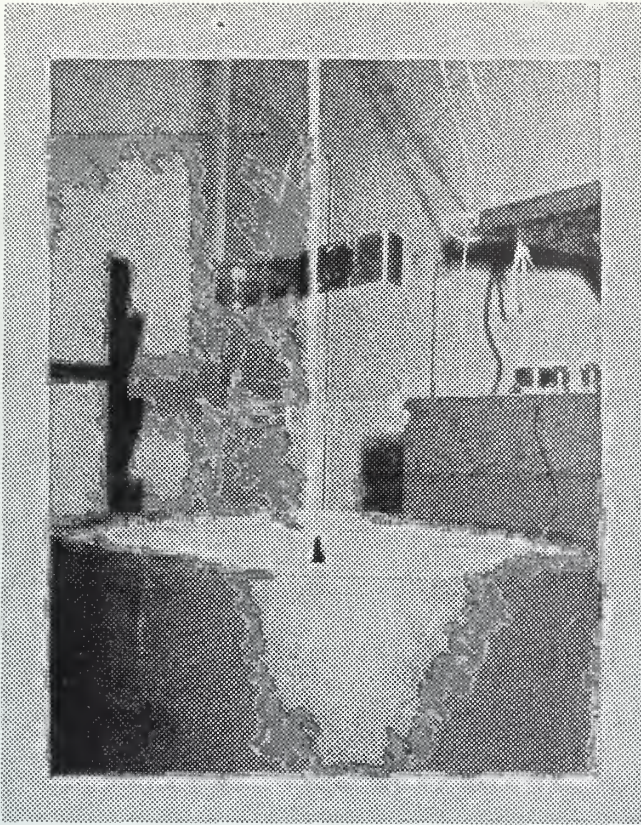
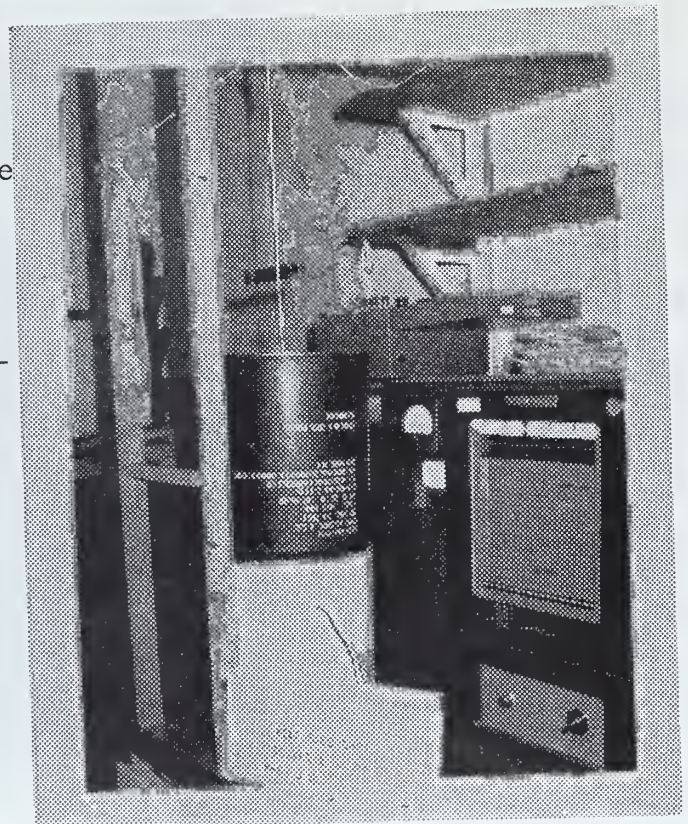

Figure 5a. All specimens were suspended side by side as shown. A pulley arrangement was used to raise and lower them from and into the salt bath.

Figure 5b. The specimens as shown in Figure 5a were lowered through an empty ten gallon can serving as a warming and cooling compartment. Beneath it is shown the salt bath container. In the right foreground is the temperature control unit.



The specimens were then placed in an environment stabilized at 23°C and 45% relative humidity. After 24 hours they were then loaded to failure on an Instron testing machine. The specimens were loaded by fixtures mounted in the crossheads of the Instron as shown in Figure 6. The loading notch of the specimen was contacted by the recessed edges of the fixtures which thus acted approximately as knife edge loading points. Crosshead loading speed was .05 inches per minute and typical loading times to failure were less than 4 seconds.

Prior to each days set of fracture runs the Instron testing machine was calibrated to 10 pound loads. Each specimen was measured by micrometer prior to testing. Values for $2t$ and w were made with a vernier micrometer.

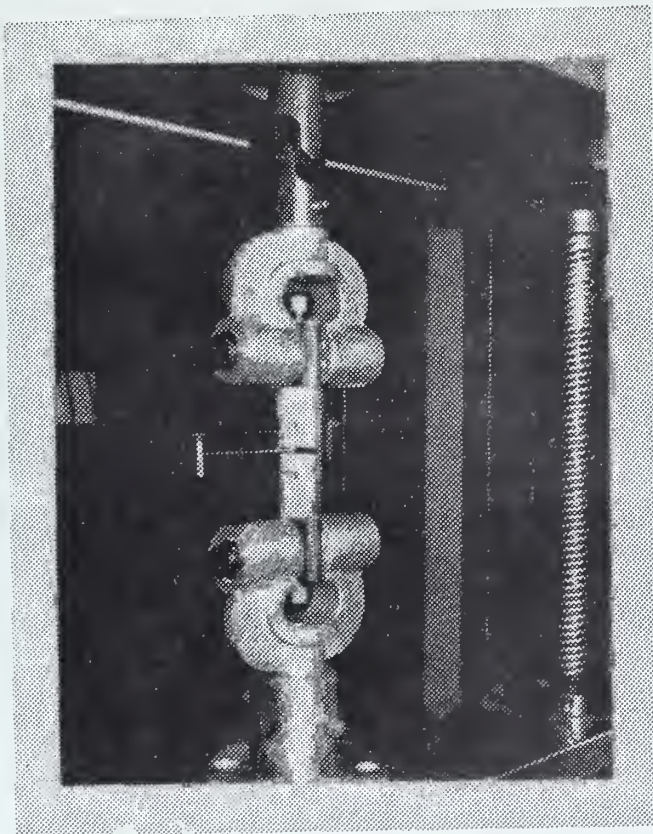

Figure 6. A specimen is shown mounted in the loading fixtures. Each of the two fixtures are held by the vice grips of the Instron loading machine.

Values of b, thickness between grooves, were measured using a homemade micrometer attachment similar to a thread micrometer. These measurements were made to $\pm .002$ inches and were taken at the crack tip. Crack lengths were measured by magnifying glass and rule to $\pm .01$ inch.

A strain guage extensometer attachment was used on several runs to determine opening arm displacement and to get an output plot of load verses displacement.

VI. RESULTS AND DISCUSSION

A. SPECIMENS USED

Approximately 300 specimens were made for the experiments. Of this number 106 were used as data points for the basis of this work. The balance of the specimens either were used in initial experimenting before a standard method was developed, broke, or were rejected for various reasons to be described. Even though the specimen design was kept quite simple, approximately thirty to forty five minutes time, excluding ion exchange treatment time, was involved in preparing each specimen prior to actual fracture. Appendix A describes a method of precracking which would allow more efficient specimen preparation.

Of the 106 data points actually used, 11 were specimens fractured before any treatment to determine the fracture toughness of the glass used. Sixty-two were specimens treated by the ion exchange method for various time periods to determine its strengthening effect and 33 were specimens covered with a protective coating to isolate the manner of ion diffusion. All of the ion exchange treatment time series were treated in a KNO_3 salt bath held at 365°C .

B. DISCUSSION OF SPECIMEN BEHAVIOR

After treatment in the bath and before fracture, some of the cracks appeared to have healed at the crack edge as shown in Figure 7b so that the crack was no longer straight

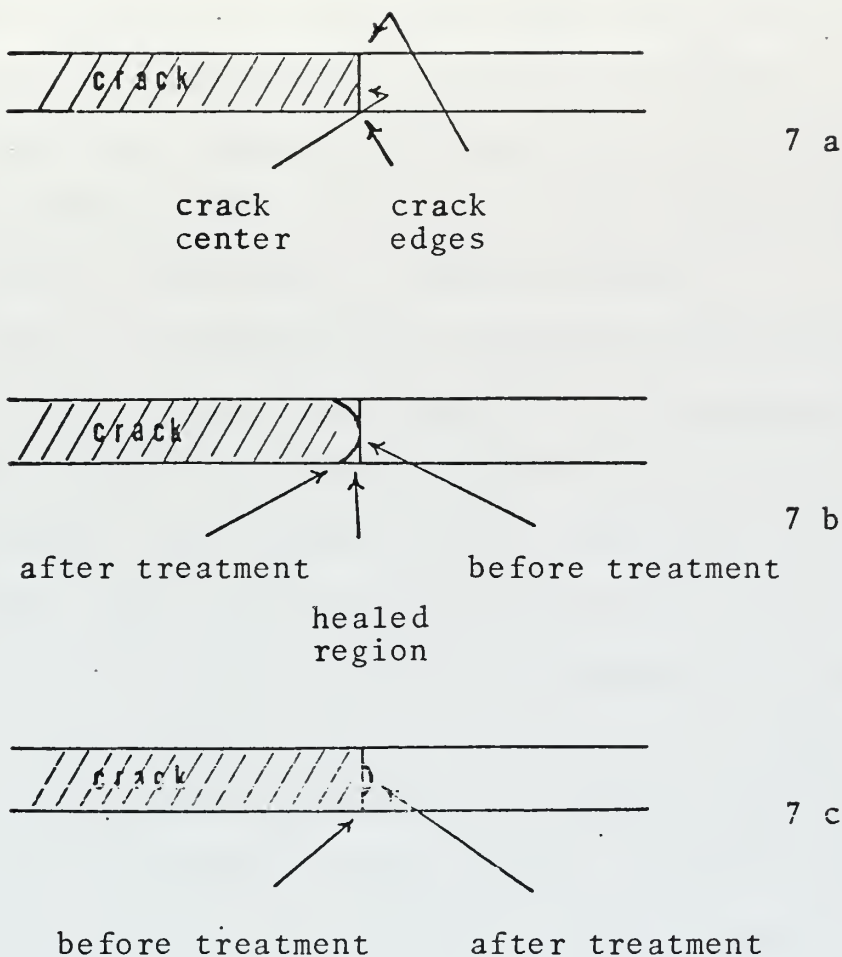

Figure 7. Figure 7a shows the location of the crack edge and the crack center. Figure 7b shows the effect of healing at the crack edges. Figure 7c shows a slight extension of the crack center.

across the specimen. This occurred in a random nature throughout the test series. Upon loading, the healed portion reopened to the original length well below the fracture load. The length of the crack at fracture was then identical to its length prior to treatment.

An equally random effect noticed was one in which the crack center appeared to have moved ahead very slightly during the salt treatment process as shown in Figure 7c. In this case the crack edges did not move prior to complete fracture of the specimen. Neither of these effects had any influence on the resulting G_c values obtained.

At times the crack was also observed to be extending not just in the center, as in Figure 7c, but completely across the specimen and running a good distance from its original length. The specimens whose cracks had run for a considerable amount were tested by fracture if the crack had remained in the guide grooves, and values of G_c were obtained. These values showed no increase in strength showing that the crack extension had occurred either near the end of the treatment or upon removal. This was not a thermal shock problem as considerable time was spent cooling the specimen on removal to reduce this problem. Also, if it had been a thermal stress problem all or most of the specimens in the batch could be expected to show the same effect. However, it would occur to any number in a batch, from zero to eight out of eight. None of these specimens were used for data.

A possible explanation for the slight crack movement which occurred only in the center is that the compressive layer on the surface of the specimen near the crack tip induced a tensile stress in the center of the specimen. This tensile stress could be great enough to cause the

crack to extend. Movement would not occur at the outside ends of a crack since here a compressive stress was being built up. If the ion exchange transfer was taking place equally across the crack tip completely through the specimen this tension in the center should not have moved the crack at all. This lended evidence to the possibility that the ion exchange was not taking place in equal amounts across the entire front of the crack tip. To investigate this possibility it was decided to treat specimens in identical manners but with half of them coated over the surface near the crack tip. The specimens were covered in the area near the crack tip with a cement of high resistance to temperature and to chemical attack. This was to reduce the effect of ion exchange taking place from the edges in and to make the diffusion take place along the crack so that an equal effect would be felt across the crack tip.

Subsequently, runs were performed with specimens coated in the area surrounding the crack tips. All of these runs yielded similar variation in results as before. Some specimens showed no change, others had crack motion of various degrees from small (less than .01 inch) extensions in the center to complete fracture. Some of these longer cracks were observed to move upon removal from the salt bath or when immersed in the water. Figure 8 shows such an occurrence. The scribe mark on the specimen indicates the original crack length. Before the picture was taken the crack moved about 1/4" to the position indicated

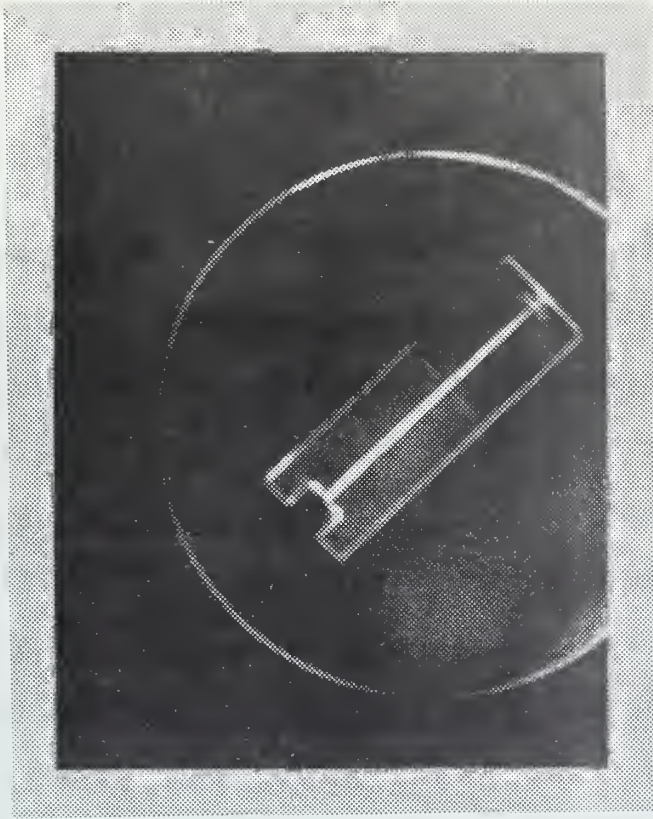
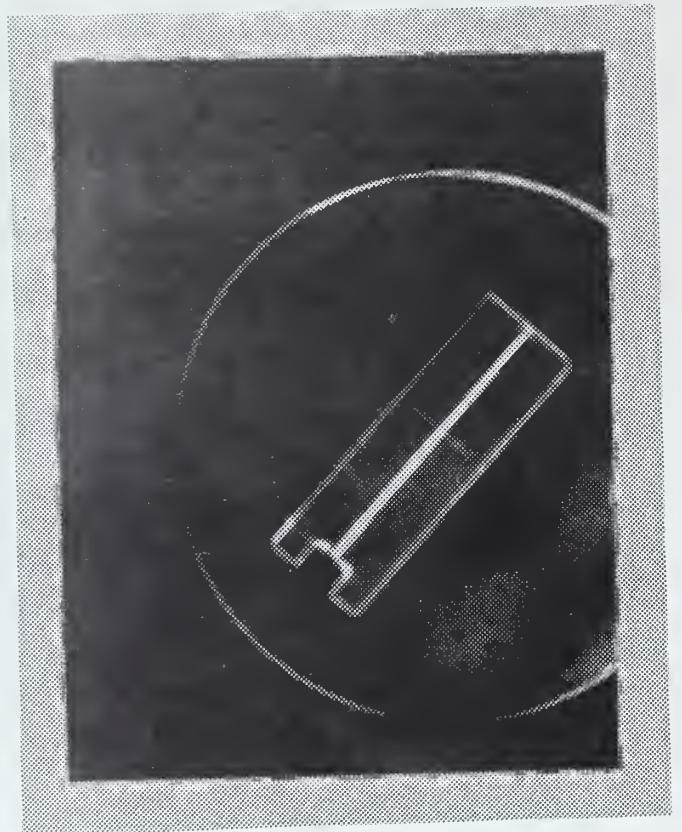

Figure 8a. The position of the moving crack is indicated by the stress pattern nearing the end of the specimen. The original crack length is indicated by the scribe line.

Figure 8b. The crack has moved to almost the end of the specimen. This picture was taken approximately two minutes after the above picture.



by the stress pattern in Figure 8a. Within moments it had moved to the position indicated by the stress pattern shown in Figure 8b. It halted there but continued to run to the end of the specimen when immersed in water. This type occurrence indicated the possibility of stress corrosion cracking. When the specimen was removed from the bath it encountered an immediate drop in temperature to approximately 75°C below the melting temperature of the salt. As a result, salt immediately solidified in the crack. This solidification takes place at the outside of the crack first which cooled the most rapidly. Thus, what salt was in the crack was now constrained to the crack. This salt gave rise to tensile stresses acting on the crack tip which were investigated with the use of a polarized light source and a polarizer analyzer. Figure 9 shows a specimen just removed from the bath with the solid salt in the crack. A definite stress has been induced in the specimen as shown. This stress, combined with water vapor in the air, or the water in which it was subsequently immersed, constituted a definite stress corrosion environment. This effect was countered by applying a compressive stress in the region of the crack tip with a standard C-clamp. The clamp was applied as soon as possible after removal from the liquid salt and at a temperature above 100°C . The resultant stress and clamp position is shown in Figure 10. The specimen was then immersed in water until the salt was dissolved, a period usually less than six hours. This method was used



Figure 9. Stresses shown are caused by KNO_3 salt which has solidified in the crack. The specimen had been immersed in the KNO_3 bath at 365°C for thirty minutes.

Figure 10. Stresses shown are the result of the compression caused by C-clamp application to counteract the tensile stress caused by the salt in the crack. This specimen is the same one shown in Figure 9 above.



the remainder of the test series and very few additional specimens were lost due to the crack running. However, a slight extension in the center still occurred occasionally as discussed previously.

An interesting effect noticed in a few specimens was that of apparent crack healing. Upon removal from the treatment bath it was noted that some cracks were shorter than when immersed. In one particular uncoated specimen the crack had apparently healed 0.33 inches. Upon fracture two values were obtained from the chart of load values. The first occurred at the new shorter crack length and resulted in a value of $G_c = .0526 \text{ in-lbf/in}^2$. The crack ran on fracture to its initial length while the load dropped off quickly. The crack then held while the load again climbed until final fracture. This second value gave $G_c = .0546 \text{ in-lbf/in}^2$. Since it had been treated for twenty four hours, it was not possible to determine how much strengthening had taken place versus how much of its original strength the glass retained as the flaw healed. But apparently it had healed since no salt had reached the original crack tip. This was not only verified visually before removal of the salt, but the G_c value for the original crack is what could be expected of an untreated specimen. As seen from the value of G_c at the shorter crack length the combination healing and ion exchange treatment had made the glass as strong as it was originally. Since the amount of ion exchange strengthening was not isolated for these specimens, they were not used for data.

The majority of specimens tested fractured within the side grooves for the length of the specimen as illustrated in Figure 11. The remainder of the specimens fractured with the crack following the side grooves for a small distance and then curved out to the edges of the specimen as illustrated in Figure 12. Those that curved off in this manner were used for data only if the crack initially followed the grooves and did not immediately move into the full thickness portion of the specimen. This fact could be ascertained by visual observation and also by analysis of the chart recording of load versus crosshead motion. At initial fracture or crack motion the load was observed to fall off rapidly. As the crack left the groove and entered the thicker portion a slight increase in load would be observed on the recording prior to complete fracture and total load fall off. The initial maximum was the value used for P in Equation 3. If the crack left the groove without this loading behavior the specimen was not used for data. It was determined, however, that by measuring the new crack length to the point at which it left the grooves and using this value of crack length, a , substituting w^2 for $w \cdot t$, and the associated second maximum in the load recording for P in Equation 3, the values yielded for G_c remained well within the deviations of all samples. This afforded a secondary check of the validity of Equation 3 and the values netted for the untreated standards. These values were not used, however, as for treated specimens they were

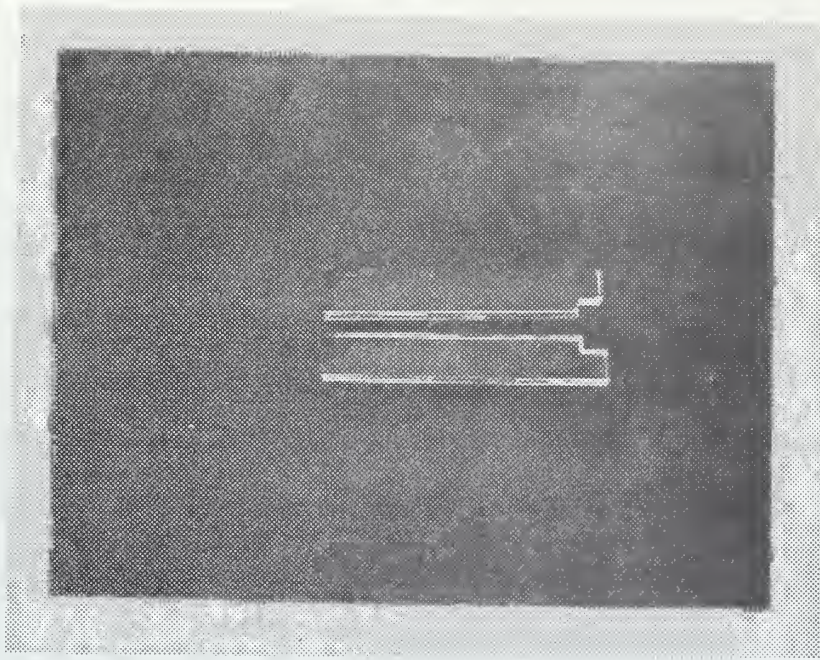

Figure 11. The majority of the specimens fractured in the manner shown with the crack following the side grooves.

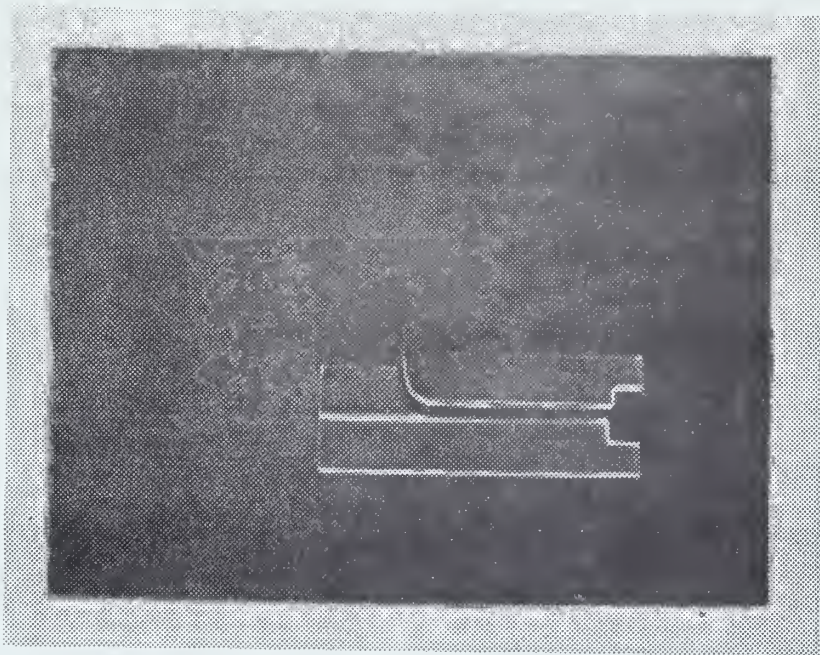

Figure 12. A fracture which did not follow the side grooves. Most of these type fractures did follow the grooves for some distance prior to leaving them.

not representative of a strengthened flaw. Also, the exact effect of having the crack widen as it entered the thick portion of the specimen could not be accounted for.

Several of the specimens were tested with a strain gauge extensometer as an accessory. This gave an Instron chart output of load versus specimen arm extension as a direct plot. The purpose of this phase of the experiment was to more closely determine the exact nature of the fracture. As seen in Figure 13, a reproduction of the plot of one such test, the fracture was the result of a load increasing steadily to a critical value. Since the plot is a straight line, as expected [23], there was no "pop-in" type behavior common with such tests of metals. It should be noted that the displacement gauge used was too large to be placed across the specimen and thus had to be placed across the fixtures holding the specimen. This may account for the nonlinear portion of the curve seen at the beginning of the loading sequence.

C. DATA

Table II lists the results of the tests listing the average critical energy release rate, G_c , and the average fracture toughness, K_c , with standard deviations. Table III lists the maximum values obtained for G_c and K_c at each sample point in time.

Figures 14 and 15 show a plot of G_c versus treatment time of all the uncoated and coated specimen data points respectively used for the averages, standard deviations and

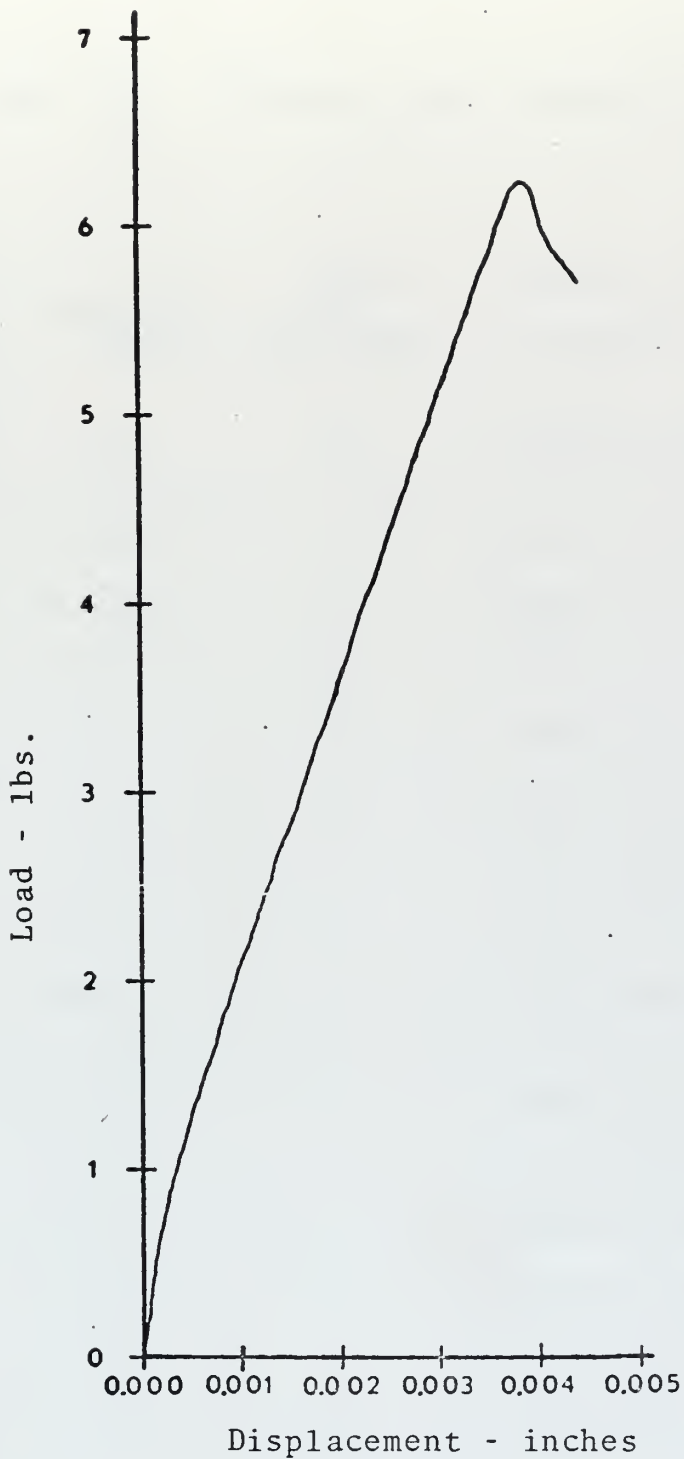

Figure 13. Load vs. Displacement plotted by an Instron testing machine using a strain gauge extensometer. Specimen was uncoated, treated in a KNO_3 bath at 365°C . for sixty four hours, and had a crack length of 1.61 inches.

Table II. AVERAGE G_C and AVERAGE K_C

TYPE OF SPECIMEN	TREATMENT TIME	NUMBER OF SPECIMENS	AVERAGE G_C in-lbf/in ²	AVERAGE K_C lbf/ $\sqrt{\text{in}^3}$ ($\times 10^{-2}$)
Untreated Standards	n.a.	11	0.0509 \pm 0.0061*	7.3024 \pm 0.4239
Uncoated	0 hrs	5	0.0514 \pm 0.0046	7.3451 \pm 0.3287
	6 hrs	11	0.0682 \pm 0.0112	8.4376 \pm 0.6899
	12 hrs	12	0.0892 \pm 0.0207	9.6192 \pm 1.1074
	18 hrs	12	0.1066 \pm 0.0276	10.491 \pm 1.3917
	24 hrs	14	0.1231 \pm 0.0250	11.312 \pm 1.1588
	33 hrs	2	0.1077 \pm 0.0396	10.449 \pm 1.9993
	46 $\frac{1}{2}$ hrs	4	0.1587 \pm 0.0200	12.887 \pm 0.8149
	64 hrs	2	0.2107 \pm 0.0072	14.879 \pm 0.0254
Coated	0 hrs	2	0.0558 \pm 0.0029	7.6542 \pm 0.1960
	6 hrs	7	0.0573 \pm 0.0033	7.7578 \pm 0.2273
	12 hrs	7	0.0596 \pm 0.0091	7.8938 \pm 0.5698
	18 hrs	6	0.0528 \pm 0.0080	7.4294 \pm 0.5674
	24 hrs	7	0.0597 \pm 0.0081	7.9002 \pm 0.5347
	48 hrs	3	0.0558 \pm 0.0014	7.6584 \pm 0.0931

* Uncertainties are standard deviations.

Table III. MAXIMUM G_c and MAXIMUM K_c

TYPE OF SPECIMEN	TREATMENT TIME	MAXIMUM G_c in-lbf/in ²	MAXIMUM K_c lbf/ $\sqrt{\text{in}^3}$ ($\times 10^{-2}$)
Untreated Standards	n.a.	0.0635	8.1693
Uncoated	0 hrs	0.0560	7.6681
	6 hrs	0.0884	9.6383
	12 hrs	0.1298	11.679
	18 hrs	0.1558	12.797
	24 hrs	0.1655	13.188
	33 hrs	0.1473	12.443
	46 $\frac{1}{2}$ hrs	0.1852	14.020
	64 hrs	0.2179	15.132
Coated	0 hrs	0.0586	7.8502
	6 hrs	0.0617	8.0497
	12 hrs	0.0809	9.2226
	18 hrs	0.0653	8.2842
	24 hrs	0.0655	8.2964
	48 hrs	0.0577	7.7874

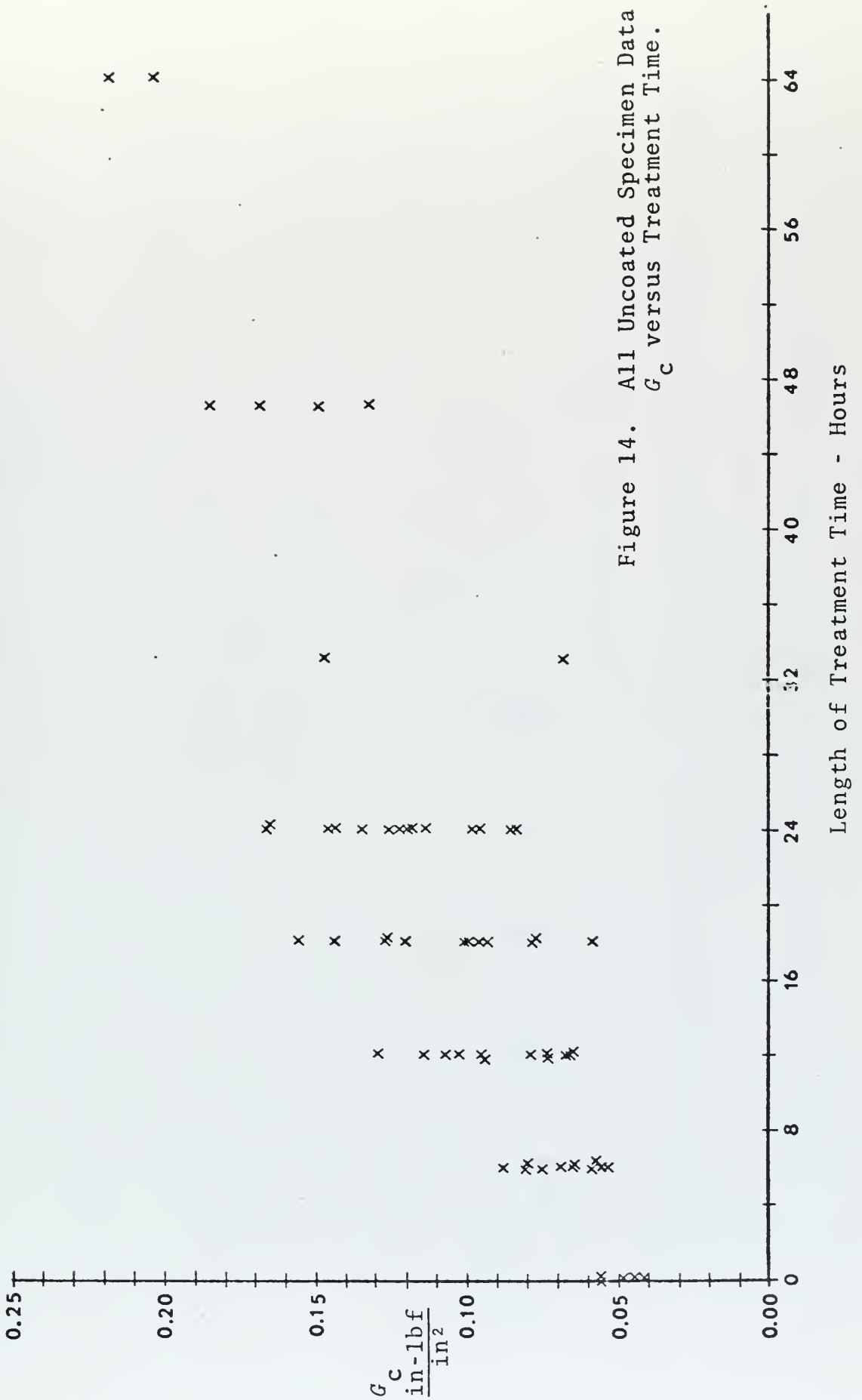

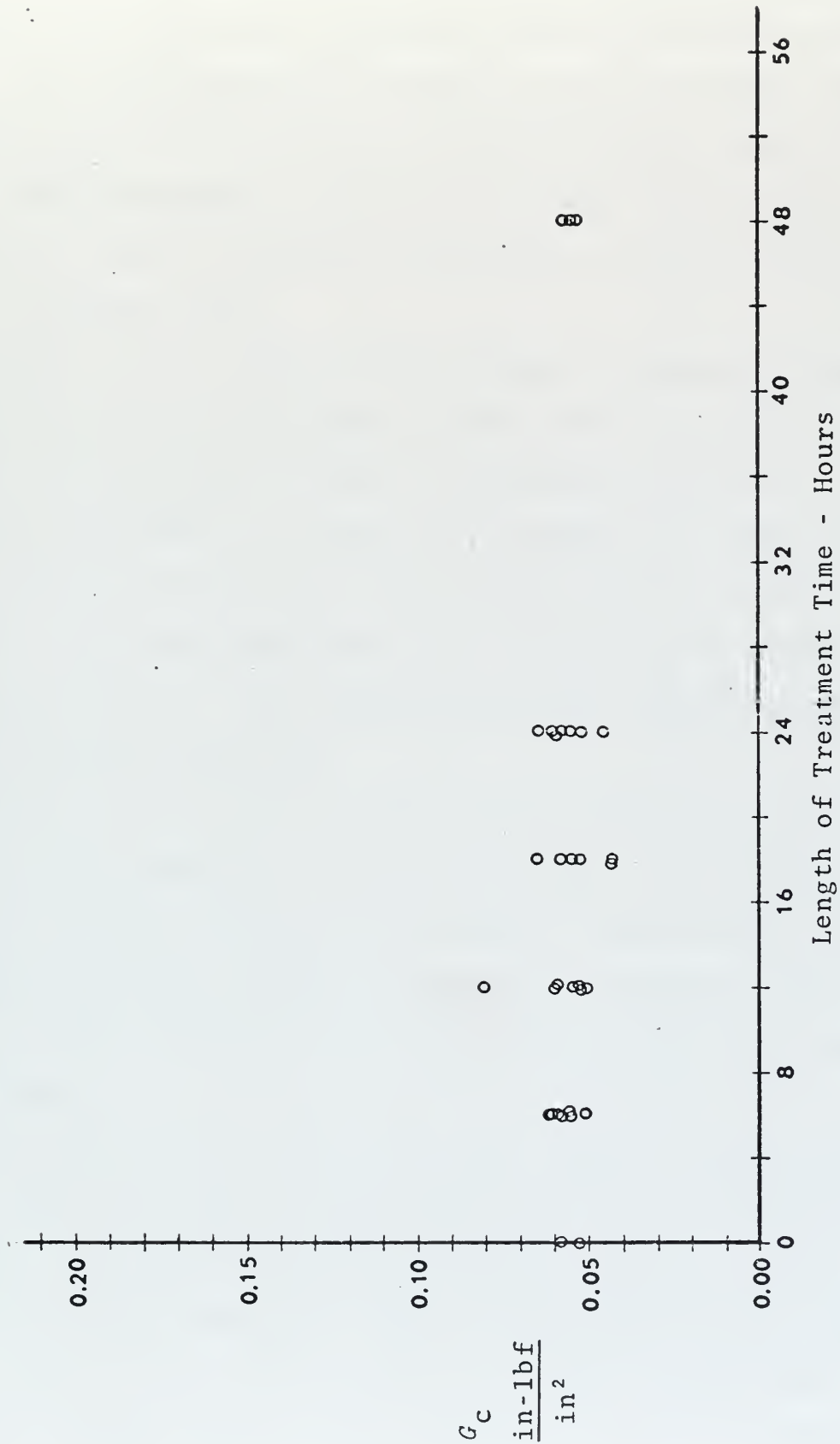

Figure 15. All Coated Specimen Data. G_C versus Treatment Time.

maximum values listed in Tables II and III. All cement was removed from the coated specimens prior to fracture testing. Note the wider spread of G_c values at any particular time for the uncoated specimens as compared with the coated ones. Also note the spread in Figure 14 is about the same for any particular time but progressively higher on the G_c scale with increasing time.

Figure 16 is a plot of the average G_c values for the coated and uncoated specimens versus time with standard deviations also plotted. Note the standard deviations on the uncoated specimens are essentially constant for times greater than six hours but all are progressively higher on the G_c scale. The relationship definitely appears to be linear to twenty four hours. The uncoated specimens exhibit a constant relation with time.

Figure 17 is a plot of the maximum values of G_c obtained at any particular time of treatment versus time for both the coated and uncoated specimens. The uncoated specimens again show a definite linearity to eighteen hours with a slight downturn of the curve from eighteen to twenty-four hours.

This downturn of the curve above eighteen hours prompted some longer time tests which were carried out to determine if this trend would continue or if more data was required at the twenty four hour point. Due to the time involved only a few samples were run at each of the long time periods. Figure 18 shows a plot of all the above data for average G_c

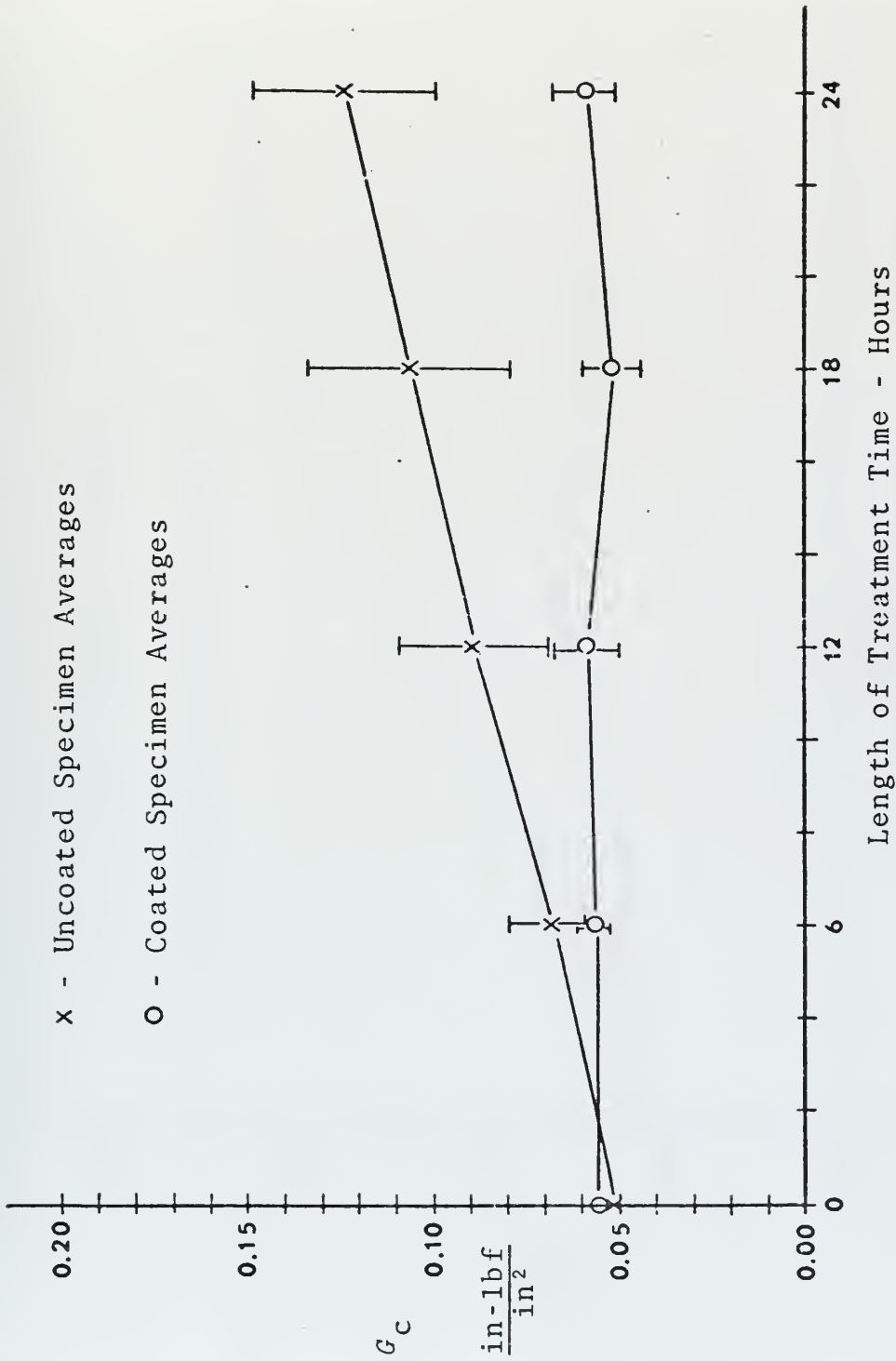

Figure 16. Average G_C with Standard Deviation vs. Treatment Time.

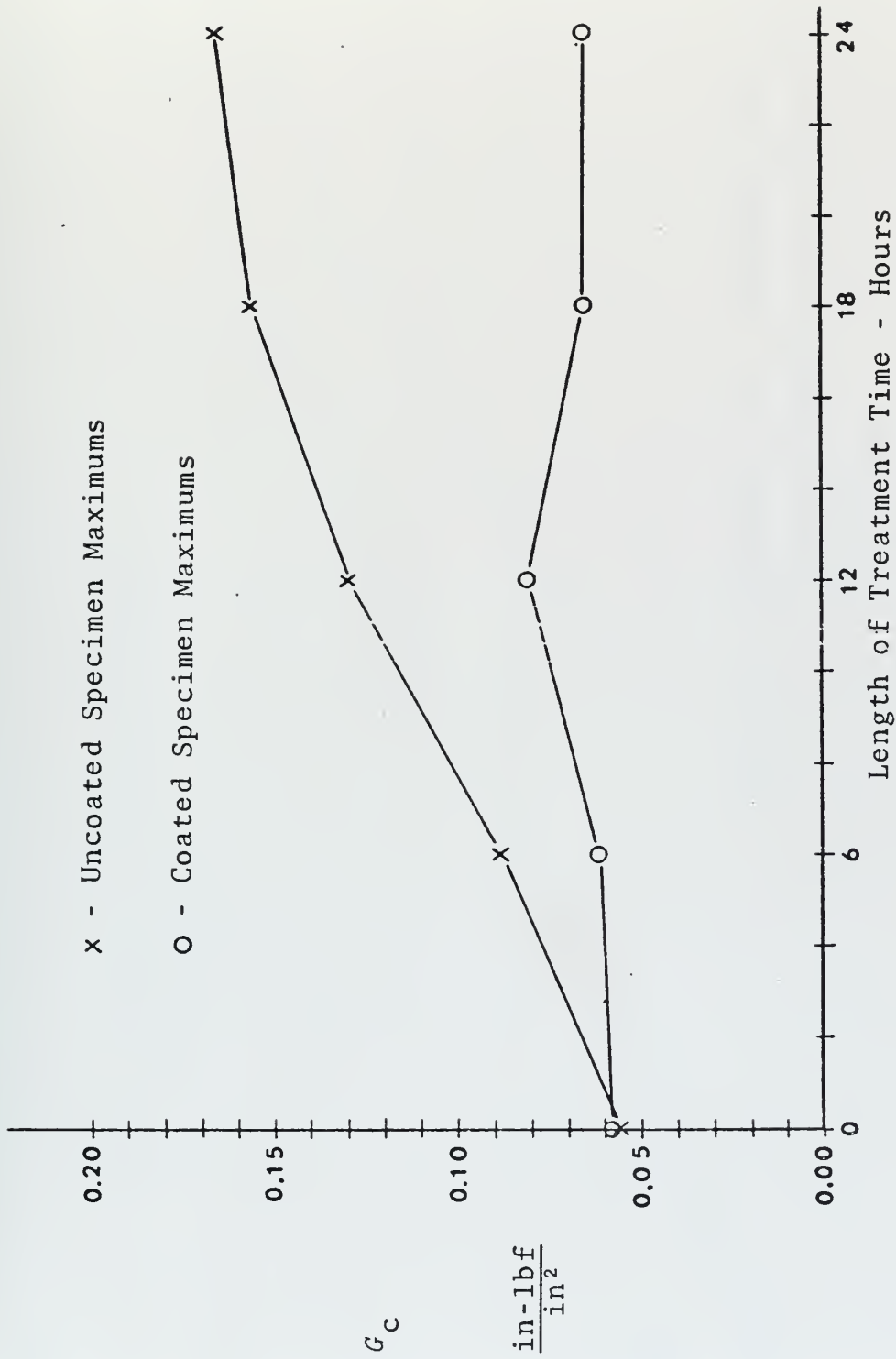

Figure 17. Maximum G_C vs. Treatment Time.

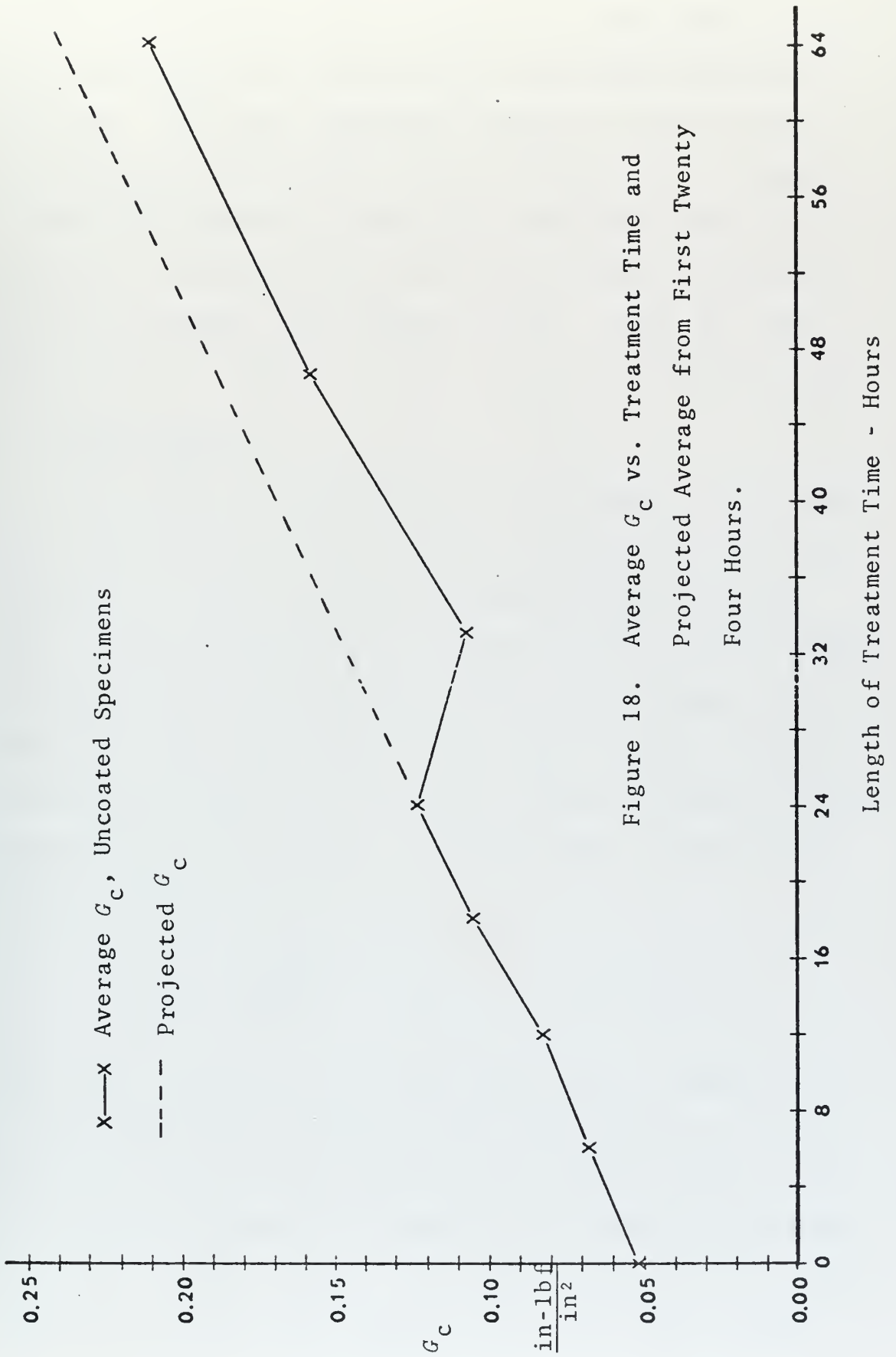

Figure 18. Average G_c vs. Treatment Time and Projected Average from First Twenty Four Hours.

values plus the long time averages. It also shows a projected average curve from the data for twenty-four hours and less. This plot illustrates that the effect of increasing G_c is continuing, but at a lesser rate. Figure 19 shows the maximum G_c values for less than twenty-four hours and a projected curve from these values along with the long treatment time maximum values. Again the long time values are higher but fall below the projected curve.

D. DATA ANALYSIS

The values of G_c obtained in this paper for the standard untreated glass specimens bear comparison with those obtained for soda-lime glass by previous investigators. Table IV shows the values of surface energies calculated by various previous investigators [24]. The average G_c obtained for the glass used in this paper is quite readily converted by Equation 2 to surface energy (assuming plastic deformation is negligible). The resultant average value for the surface energy, γ , is

$$0.0254 \frac{\text{in-lbf}}{\text{in}^2} \quad \text{or} \quad 4.46 \text{ Joule/M}^2.$$

This value compares within the same order of magnitude of all the references in Table IV and very closely to those values determined by Wiederhorn for soda lime glass [24]. These values can only be compared on an order of magnitude basis for several reasons. The major of these is that the composition of all the glasses is not the same although

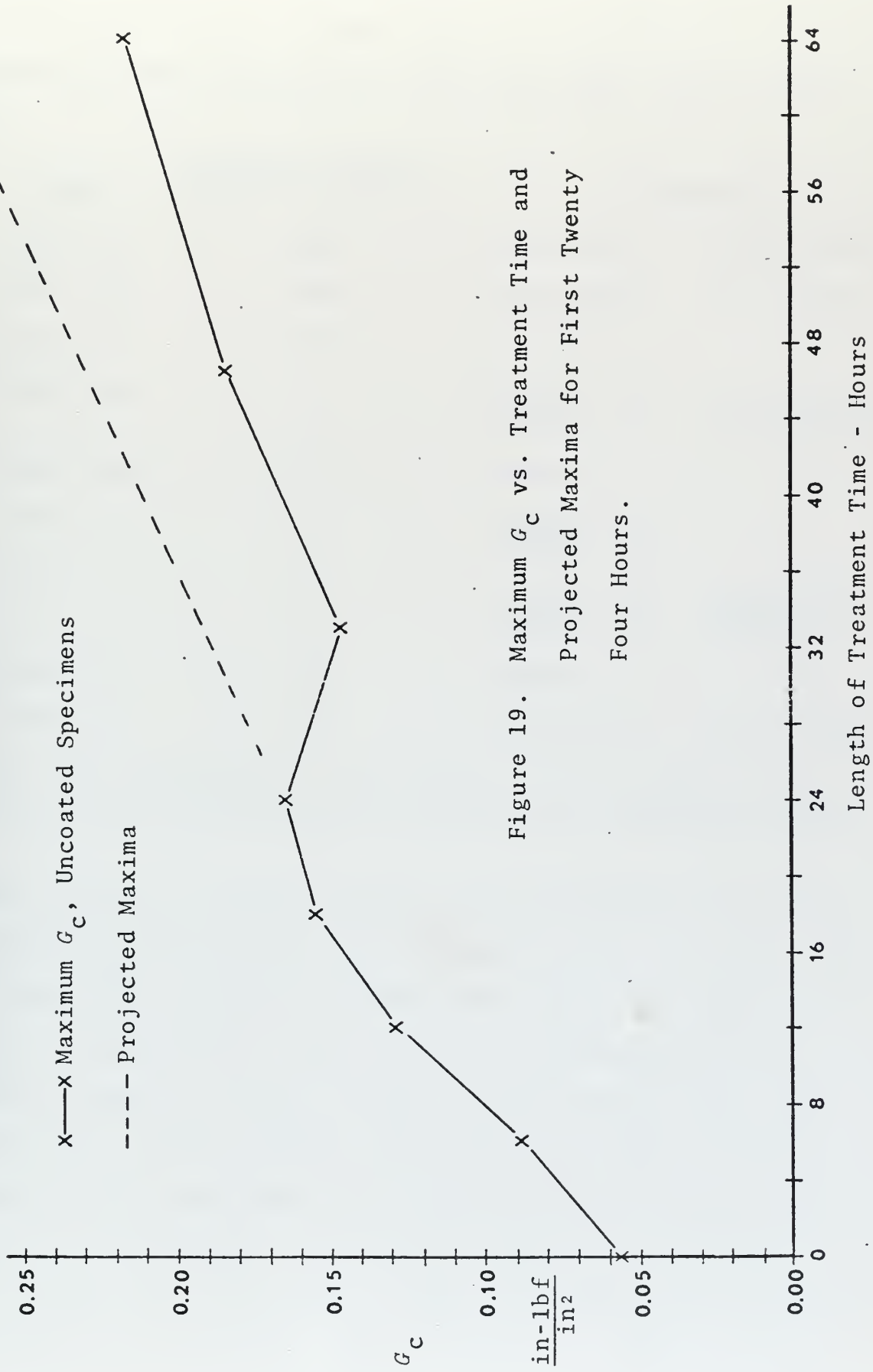

Figure 19. Maximum G_c vs. Treatment Time and Projected Maxima for First Twenty Four Hours.

Table IV.

FRACTURE SURFACE ENERGIES OF SODA-LIME GLASS, OTHER STUDIES

GLASS	FRACTURE SURFACE ENERGY JOULE/M ²	REFERENCE	
Soda-Lime	3.91	Wiederhorn	N ₂ (g) 300°K
Soda-Lime	4.06	Berdennikov	in vacuum
Soda-Lime	1.8-10	Roesler	
Soda-Lime	4-7	Davidge and Tappin	work of fracture method
Soda-Lime	3.4-5.2	Nakayama	
Soda-Lime	6-7	Davidge and Tappin	
Soda-Lime	8-11	Davidge and Tappin	Compliance Method
Soda-Lime	1.70	Shand	
Soda-Lime	4.52	Wiederhorn	N ₂ (l) -77°K

NOTE: All measurements were obtained at room temperature using Griffith-type equations except where otherwise stated.

quite similar. Another reason is the difference in various configurations of cracks and load applications for each case. Although the methods and results found here are closest to those of Wiederhorn, there are certain variations in procedure, namely, the use of center guide grooves and a difference in loading methods. The close agreement of values found in this experiment with previous work is reassurance that the analysis and experimental technique are valid. A last variation in procedure is the environment in which the specimens are fractured. All the values of Table IV were

obtained at room temperature but humidity and rates of loading could have varied widely. This would result in a variation of values.

When the first specimens were being run through the salt bath and values of G_c were obtained it was quite obvious that a strengthening effect was taking place. It was also obvious that it was directly related to time and that strengthening began taking place in a fairly short time. Although salt did not penetrate the crack in a matter of seconds, it did so in less than ten minutes by observation. However, the strengthening can not be said to be due to ion exchange creating a compressive layer without first eliminating other possible effects. A possible reason for an increase in strength was the blunting of the crack tip by the high temperatures and length of time involved in the treatment. To ascertain the degree of this effect, groups of specimens were annealed after cracking at temperatures which were at least 150°C higher than that used in the salt bath. The values of G_c obtained by fracturing these specimens were higher than unannealed standards but still fell within the standard deviations of the standards. All samples were immersed in water after removal from the bath to remove the salt which had solidified within the crack upon removal from the bath. This was initially done to standardize the experimental procedure as much as possible. This included having all cracks in the same condition, i.e., salt free. As noted earlier this was also required to inhibit stress corrosion cracking. It has been shown that immersion of

stress free glass in water will have a strengthening effect [7]. Therefore, specimens which were untreated were immersed in water for 24 hour periods and tested for any increase in strength. Again a slight increase (less than 10%) was noticed for a twenty four hour immersion period. Since no specimens were immersed over twelve hours for removal of salt this was not considered to be significant.

Another direct evidence of the time dependent strengthening is evident in Figures 9, 20-22. These photographs, showing various stress patterns, were taken by time exposure of specimens seen through a polarizer and analyzer. Figure 20 shows two specimens with different stress patterns. The specimen on the left was not treated in the salt bath and no stress pattern is seen near the crack tip or elsewhere in it. The other specimen was treated for $\frac{1}{2}$ hour and a small effect of the compressive layer built up in this short period can be seen by the very slight stress pattern. Figure 21 shows two specimens also, the one on the left was treated for $\frac{1}{2}$ hour and the other for twenty-four hours. Here a large difference can be seen in the stress patterns. The difference in stress patterns of specimens from one hour to the next is very slight. The only discernible difference is in the shading of the fringes as the number of fringes did not increase in twenty-four hours. This time dependence can also be seen in the differences evident in stress patterns shown in Figures 9 and 22. Figure 9 shows a stress pattern due to solidified salt in the crack of a



Figure 20. Increase of compressive stress with time. The specimen on the left is untreated; the one on the right was treated for one half hour.

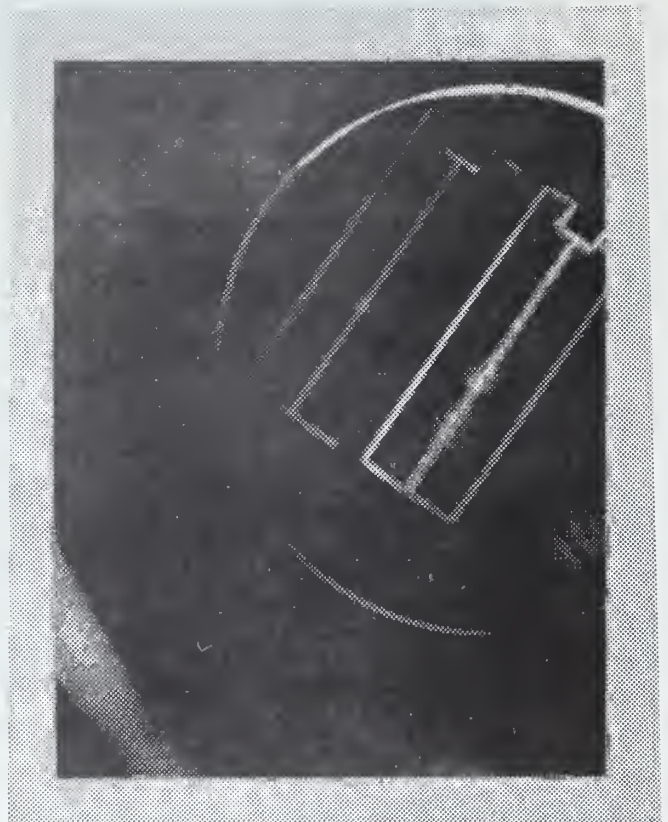

Figure 21. Increase of compressive stress with treatment time. The specimen on the left was treated for one half hour; the one on the right was treated for twenty-four hours.

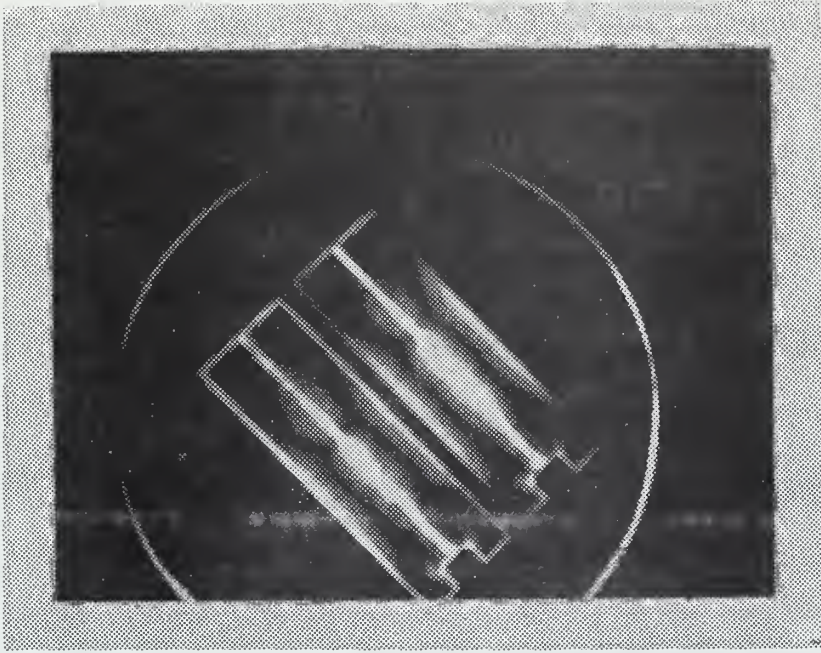
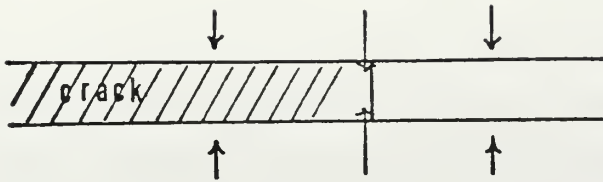

Figure 22. Two specimens which were treated for twenty-four hours with the stress patterns caused by solidified salt in the cracks.

specimen treated for one half hour. Figure 22 shows two specimens treated for twenty-four hours with the salt in the cracks. Note the evenness of the pattern of the one half hour specimen as against the irregularities in the patterns of the other two. The twenty-four hour specimens have had much larger compressive stresses built up in the surface, at the crack tip, and at any of the multiple small flaws present in the saw cut side grooves. This compressive stress must be overcome by the tensile stress exerted by the salt. The strong overall resemblance of the two patterns is indicative of the relatively strong tensile force exerted by the salt. Indicative also of the longer treatment time are the greater surface compression stresses shown around the corners of the loading notches on the twenty-four hour samples.

Data obtained from the specimens which were coated around the crack tip did lend strong evidence that the strengthening was due to ion exchange at the edges of the crack tip and not, to any large degree, by ion exchange strengthening across the entire crack tip. As seen in Figures 15-19, the large time dependent increase in strength for uncoated specimens was not seen in those that were coated. In fact they showed very little strength increase at all over untreated standards. Thus, the diffusion of ions was taking place across the specimen surface, affecting the edges of the crack, as shown in Figure 23a, and not from the length of the crack as in Figure 23b. The reason for this



23 a

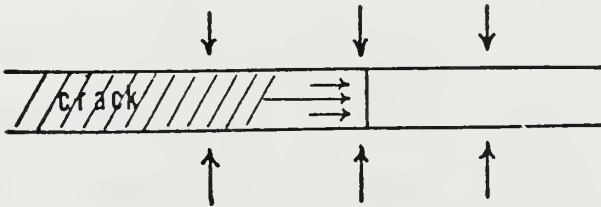

23 b

Figure 23. The arrows show the direction of diffusion of salt in the specimens. Figure 23a shows diffusion at the crack tip from the edges of the specimen. Figure 23b shows diffusion along the crack surfaces to the crack tip.

behavior is believed to be that a relative equilibrium in ion concentration in the crack is reached quite quickly. This salt has a high concentration of K^+ ions and a low concentration of Na^+ ions. The glass has an opposite concentration high in Na^+ and low in K^+ . Therefore, the ion exchange begins by the diffusion process. The process continues until the salt and the surface of the glass in the crack have reached approximately the same concentration of both Na^+ and K^+ ions. If the salt is free to circulate over the surface, the process will not reach equilibrium until the entire bath is saturated with Na^+ ions or until a layer of K^+ ions on the glass surface reaches a thickness which essentially slows

any further diffusion to a negligible speed. It is postulated that the problem here was that the salt is not circulated well at all within the crack of the specimen. It was in fact only wetting the interior of the crack and not moving through it. Therefore, it reached an equilibrium concentration with the surface of the crack and the crack tip very quickly. Then the diffusion was required to be from the sides of the crack through the salt within the crack and thence to the glass itself. As seen by the results of the coated specimens this process is a very long one. Thus, the diffusion of ions was taking place almost entirely as shown in Figure 23a.

As mentioned, when comparing the fracture surface energies of the untreated standards to those found in other papers, the value was found to be 0.0255 in-lbf/in². This corresponds to a G_c value of 0.0509 in-lbf/in². As shown in Figure 16 the average G_c value for the zero time treatments of both coated and uncoated specimens and the average G_c values for all the coated specimens were somewhat higher ranging from 0.0514 in-lbf/in² for the zero hour uncoated to 0.0597 in-lbf/in² for the 24 hour coated specimens. This small degree of strengthening exhibited by the uncoated specimens at zero time length and all the coated specimens over the G_c values determined for the untreated glass can be explained by several factors. Both of these type specimens were exposed to the high temperature of the bath which resulted in a certain amount of crack tip blunting. Both were

subject to the tensile stress of the salt upon initial cooling and both were immersed in water for removal of that salt. The first of these conditions could also have caused some crack tip blunting and the other could have strengthened the glass if it was in the water when the salt was dissolved and the stresses were nearly zero. The fact that all these factors were essentially constant for all the specimens is reflected by the fact that all the coated specimens plot in an essentially straight line and that the zero time uncoated specimens match the zero time coated ones so well. All the uncoated specimens also underwent the same processes so the increase in strength with time of these specimens cannot be said to be due to any of the above but definitely due to the ion exchange treatment.

A last question to be examined was that of the wide scatter of data as exhibited by Figure 14 in the uncoated specimens. Perhaps the best answer to this question lies in the very nature of glass, i.e., its extreme brittleness. Because of this brittleness the results were very susceptible to any discrepancy in the specimen and its crack from the exact restrictions placed upon it by the fracture mechanics formulation used. These restrictions were; one, cantilever arms of equal and constant height, i.e., crack in the exact center of the specimen, two, the crack tip must be perpendicular to its length, and three, the crack tip must not be veering off from center by any amount at its tip. Any discrepancy from these requirements resulted in the fracture not taking place exactly as required. A

second problem area which affected the scatter of results was the method of loading and the environment of fracture. The loading fixtures were probably not exact knife edges and the environment ranged a few degrees either side of 70°F and between 45 per cent and 50 per cent relative humidity. The rate of loading was high enough so that environmental effects should have been minimized. This rate of loading was a constant machine loading. A third area of question is that of the very slight movement of the center of the crack tip as shown in Figure 7c. Although this occurred randomly with no apparent correlation to resultant values it was not isolated as to cause. All of the above departures from a perfect specimen, crack, and fracture environment occurred in a completely random fashion. This would explain some of the spread of values seen but certainly cannot be expected to have caused the resultant strengthening effect seen. Another factor affecting the spread of values and one which obviously was a factor in the strengthening seen was the freshness of the salt bath used. Although only one small bath was used for the entire work, twenty five pounds of KNO_3 were used. It was noted that when replacing used salt with fresh that although the spread of resultant G_c values did not decrease, the average values definitely went up. Thus; it must be concluded that the increases in strength found probably were not the maximum possible. To achieve that end result would require using salt of equal freshness for each test run. The uncoated treated specimen averages show a much

higher deviation than for the untreated or the coated specimens but the trend of values with increasing time held firm. The reproduceability of treated specimens for varying times was therefore not as good as for untreated specimens but certainly was sufficient. These deviations have been reduced over initial values by increasing the number of samples used in each group. Greater numbers of data points were not considered necessary to demonstrate the effects shown as those used show positive results.

VII. RECOMMENDED FURTHER STUDIES

The study of the ion exchange strengthening of a macro-flaw is possible by this method; however, further work is needed to analyze the complete flaw behavior. With the amount of attention being given the use of glass as a structural component in deep submergence oceanographic work and the need for more understanding of the behavior of glass, this further work should be an area of great interest. Some of the indicated directions of this work are as follows:

1. The determination of the amount of strengthening which can be expected from this diffusion from the sides and further isolation of this effect. A possible technique would be the same method of treatment using various specimen thicknesses. A plot of the empirical data, strength increase versus thickness, could be matched by analytical equations. These could then be used to extrapolate the effect to zero and infinite thicknesses. The zero point would be an indicator of all edge effects and the infinite point an indicator of zero edge effect.

2. A second technique possible is that of opening the cracks prior to treatment by annealing the specimens under tension. This would allow more freedom of circulation. Similarly, treating the specimens while under tension would allow easier ion diffusion and additionally allow for a greater resultant compressive stress.

3. The determination of the amount of diffusion which does take place in a crack such as used here would be of interest. The use of an initial short time bath containing isotope tracer elements followed by the normal long time treatment could answer this question. A determination of the isotope concentration before and after the normal treatment of varying lengths would not be difficult and would be indicative of the diffusion which takes place.

4. The effect of ion exchange strengthening on a macroflaw could possibly be studied without the problem of the diffusion coming from the sides by using a slightly different specimen. A suggestion would be to make a saw cut completely through the specimen to a length of the desired crack in place of the side grooves used in this work. The end of the saw cut would have many small microracks present. Using the double cantilever technique, these small cracks would actually have the length dimensions of the saw cut. However, Equation 3 could not be used as is but would have to be modified by experimental analysis since the cantilever arms would vary in height over the crack length.

5. The final method of precracking developed in Appendix A is recommended as the most efficient in any further studies using the specimen configuration of this work.

VIII. CONCLUSIONS

1. The ion exchange method of chemical tempering can be used to study the strengthening of a macroflaw.

2. The critical energy release rate, G_c , needed for fracture increased with time at an almost linear rate for the first twenty four hours of treatment time when pre-cracked specimens were treated in a KNO_3 salt bath at $365^\circ C$.

3. The strengthening was found to take place as a result of diffusion of ions in from the sides of the specimen rather than completely across the crack tip.

APPENDIX A: SPECIMEN PRECRACKING PROCEDURE

The use of side grooves on the specimens for this work was to help in guiding the initial crack, as well as to guide the crack at fracture. Knowing that the grooves were in the center of the specimen and parallel to the edges insured that the crack was very close to centered and parallel as long as it was within the grooves.

The scribe mark used as a stress concentrator was not extended the full length of the groove but only near the end to be cracked. Wiederhorn's data showed that having the scribe mark run the full length of the specimen had little effect on his results [24]. However, it was found that with the crack extended beyond the scribe mark, less scatter could be expected and the specimen fracture characteristics were more consistent.

The crack introduced using the fixture of Figure 4 was very difficult to control in length and never perpendicular to the specimen sides, but tended to lag behind on one side, making a further extension with a soldering iron necessary. Although this method worked very satisfactorily, there was some concern that residual thermal stresses might cause errors in resulting fracture toughness values. Therefore, the crack was further extended a slight distance on the Instron loading machine. Here again, however, cracks would often veer to one side and spoil the specimen or not remain straight across perpendicular to the

specimen edges. So to determine the effect, if any, of thermal stresses caused by use of the soldering gun the Instron was again utilized. Specimens were loaded on the Instron until the crack moved some distance along the side grooves. The crack length was then remeasured and the specimen reloaded. By this process several values of G_c could be obtained from each specimen with the first value reflecting any variation due to use of the soldering iron. After evaluation of several specimens so tested it was very apparent that the soldering iron did not leave any residual stresses which were discernable in the G_c values obtained. Therefore, any further crack extension prior to ion exchange treatment was not necessary.

A method of precracking described by Irwin [19] was attempted but found lacking for two reasons. The method involved heating the glass to approximately 220°C and stroking the edge of the glass with a water soaked brush. This caused a strong thermal gradient and a resulting crack initiation. However, small flaws in the side grooves resulted in numerous small cracks to be propagated normal to the grooves. The second problem was that it was quite difficult to make the crack long enough, and the tip was rounded and not perpendicular to the specimen edges. Therefore, the original method was utilized throughout this work.

Subsequent investigation of precracking resulted in a more efficient method which is recommended for any further work in this area. This method uses the fine tipped soldering iron and a small water brush. First a scribe mark is

made at the desired crack origin to act as a stress concentrator. The soldering iron is then applied about one half inch from the crack origin and the scribe mark is stroked with the water brush. Repeated applications moves the crack to any desired length. The method can be applied to thicker shapes by increasing the tip area of the soldering gun. Note that this method does not require the use of any loading fixture as used in this work. This results in fewer specimens being irretrievably broken. The use of any side groove to guide the precrack is therefore much less necessary. This method is recommended as it is much less time consuming and very few specimens are lost to breakage. The method was also developed and described by Sommer [21].

LIST OF REFERENCES

1. Ernsberger, F. M., "Submarines of Glass" in RESEARCH INTO GLASS, p. 191-196, Pittsburgh Plate Glass Industries, 1967.
2. Warren, B. E., "X-Ray Determination of the Structure of Liquids and Glass," Journal of Applied Physics, v. 8, p. 645-654, October 1937.
3. Condon, E. U., "Physics of the Glassy State. I. Constitution and Structure," American Journal of Physics, v. 22, p. 43-50, February 1954.
4. Pauling, L., "The Sizes of Ions and the Structure of Ionic Crystals," The Journal of the American Chemical Society, v. 49, p. 771, March 1927.
5. Condon, E. U., "Physics of the Glassy State. II. The Transformation Range," American Journal of Physics, v. 22, p. 132-134, March 1954.
6. Marsh, D. M., "Plastic Flow and Fracture of Glass," Proceedings of the Royal Society of London, v. 282, p. 33-42, 20 October 1964.
7. National Bureau of Standards Report 10565, Environmental Stress Corrosion Cracking of Glass, by S. M. Wiederhorn, p. 1-22, April 1971.
8. Burggraaf, S. J., The Mechanical Strength of Alkali-Aluminosilicate Glasses after Ion Exchange, Ph.D. Thesis, Technical University of Eindhoven, Eindhoven, Holland, 21 September 1965.
9. Griffith, A. A., "The Phenomena of Rupture and Flow in Solids," Philosophical Transactions of the Royal Society of London, v. A221, p. 163-198, March 1921.
10. Kistler, S. S., "Stresses in Glass Produced by Non-Uniform Exchange of Monovalent Ions," Journal of the American Ceramic Society, v. 45, p. 59-68, February 1962.
11. Nordberg, M. E., Mochel, E. L., Garfinkel, H. M., and Olcott, J. S., "Strengthening by Ion Exchange," Journal of the American Ceramic Society, v. 47, p. 215-219, May 1964.
12. Ripling, E. J., Mostovoy, S., and Patrick, R. L., "Measuring Fracture Toughness of Adhesive Joints," Materials Research and Standards, v. 4, p. 129-134, March 1964.

13. "The Slow Growth and Rapid Propagation of Cracks," (Second Report of a Special ASTM Committee), Materials Research and Standards, v. 1, p. 389-393, May 1961.
14. Gilman, J. J., "Direct Measurements of the Surface Energies of Crystals," Journal of Applied Physics, v. 31, p. 2209, December 1960.
15. Gillis, P. P. and Gilman, J. J., "Double Cantilever Cleavage Mode of Crack Propagation," Journal of Applied Physics, v. 35, p. 647-658, March 1964.
16. Wiederhorn, S. M., Shorb, A. M., and Moses, R. L., "Critical Analysis of the Theory of the Double Cantilever Method of Measuring Fracture-Surface Energies," Journal of Applied Physics, v. 39, p. 1569-1572, 15 February 1968.
17. Wiederhorn, S., "Effects of Environment on the Fracture of Glass," Environment - Sensitive Mechanical Behavior of Materials, edited by A. R. C. Westwood and N. S. Stoloff, p. 293-315, Gordon and Breach, New York, 1966.
18. Wiederhorn, S. M., "Influence of Water Vapor on Crack Propagation in Soda-Lime Glass," Journal of the American Ceramic Society, v. 50, p. 407-413, August 1967.
19. Naval Research Laboratory Report 1678, Moisture Assisted Slow Crack Extension in Glass Plates, by G. R. Irwin, p. 1-20, 28 January 1966.
20. Berry, J. P., "Determination of Fracture Surface Energies by the Cleavage Technique," Journal of Applied Physics, v. 34, p. 62-68, January 1963.
21. Sommer, E., "A Remark on Crack Initiation in Glass Plates," Engineering Fracture Mechanics, v. 2, p. 85, July 1970.
22. Wiederhorn, S. M. and Townsend, P. R., "Crack Healing in Glass," Journal of the American Ceramic Society, v. 53, p. 486-489, September 1970.
23. Gurney, C., "Sources of Weakness in Glass," Proceedings of the Royal Society of London, v. 283, p. 27, 20 October 1964.
24. Wiederhorn, S. M., "Fracture Surface Energy of Glass," Journal of the American Ceramic Society, v. 52, p. 99-105, February 1969.

INITIAL DISTRIBUTION LIST

		No. Copies
1.	Defense Documentation Center Cameron Station Alexandria, Virginia 22314	2
2.	Library, Code 0212 Naval Postgraduate School Monterey, California 93940	2
3.	Doctor Ned A. Ostenso Office of Naval Research 480D Arlington, Virginia 22217	1
4.	Department of Oceanography, Code 58 Naval Postgraduate School Monterey, California 93940	3
5.	Asst Professor R. B. Leonesio, Code 5416 Department of Material Science and Chemistry Naval Postgraduate School Monterey, California 93940	4
6.	Asst Professor E. B. Thornton, Code 58Tm Department of Oceanography Naval Postgraduate School Monterey, California 93940	1
7.	LT Michael J. Liemandt, USN 5653 Pray Street Bonita, California 92002	2

UNCLASSIFIED

Security Classification

DOCUMENT CONTROL DATA - R & D

(Security classification of title, body of abstract and indexing annotation must be entered when the overall report is classified)

1. ORIGINATING ACTIVITY (Corporate author) Naval Postgraduate School Monterey, California 93940	2a. REPORT SECURITY CLASSIFICATION UNCLASSIFIED
	2b. GROUP

3. REPORT TITLE
A STUDY OF THE EFFECT OF THE ION EXCHANGE METHOD OF CHEMICAL TEMPERING ON A MACROFLAW IN SODA-LIME GLASS

4. DESCRIPTIVE NOTES (Type of report and, inclusive dates)
Master's Thesis; September 1971

5. AUTHOR(S) (First name, middle initial, last name)
Michael J. Liemandt

6. REPORT DATE September 1971	7a. TOTAL NO. OF PAGES 72	7b. NO. OF REFS 24
----------------------------------	------------------------------	-----------------------

8a. CONTRACT OR GRANT NO. b. PROJECT NO c. d.	9a. ORIGINATOR'S REPORT NUMBER(S)
	9b. OTHER REPORT NO(S) (Any other numbers that may be assigned this report)

10. DISTRIBUTION STATEMENT
Approved for public release; distribution unlimited.

11. SUPPLEMENTARY NOTES	12. SPONSORING MILITARY ACTIVITY Naval Postgraduate School Monterey, California 93940
-------------------------	---

13. ABSTRACT

In recent years much research has gone into determining the behavior of glass which makes it adaptable for structural use in submersible vehicles and for oceanographic instrumentation packages. This work examines the strengthening effect of the ion exchange method of chemical tempering on a macroflaw in glass. Use of a macroflaw allows a quantitative fracture mechanics analysis of the amount of strengthening. Precracked soda-lime glass specimens were treated for various lengths of time in a potassium nitrate salt bath held at 365°C. The behavior of the macroflaw while being treated and at fracture was closely observed. The strain energy release rate, G_C , and the fracture toughness, K_{IC} , were found by using the double cantilever cleavage technique of measuring fracture surface energies. The average strengthening which occurred at this temperature was found to be almost linear with time with a maximum increase of G_C of approximately 300 per cent at twenty-four hours. The diffusion of ions was determined to be inward from the sides of the flaw rather than across the entire flaw tip.

KEY WORDS	LINK A		LINK B		LINK C	
	ROLE	WT	ROLE	WT	ROLE	WT
Strengthening of Glass						
Ion Exchange Tempering of Glass						
Double Cantilever Cleavage of Glass						
Glass Tempering and Fracture						
Fracture of Glass						

Strengthening of Glass

Ion Exchange Tempering of Glass

Double Cantilever Cleavage of Glass

Glass Tempering and Fracture

Fracture of Glass

Thesis

133634

L634 Liedmandt

c.1

A study of the effect
of the ion exchange
method of chemical tem-
pering on a macroflaw
in soda-lime glass.

Thesis

133634

L634 Liedmandt

c.1

A study of the effect
of the ion exchange
method of chemical tem-
pering on a macroflaw
in soda-lime glass.

thesL634

A study of the effect of the ion exchang



3 2768 002 11766 5

DUDLEY KNOX LIBRARY