



**Calhoun: The NPS Institutional Archive**  
**DSpace Repository**

---

NPS Scholarship

Theses

---

1968-12

# Investigation of temperature fluctuations near the air-sea interface

Ramzy, James Robert; Young, Ernest Tillson

Monterey, California. Naval Postgraduate School

---

<https://hdl.handle.net/10945/40079>

---

This publication is a work of the U.S. Government as defined in Title 17, United States Code, Section 101. Copyright protection is not available for this work in the United States.

*Downloaded from NPS Archive: Calhoun*



Calhoun is the Naval Postgraduate School's public access digital repository for research materials and institutional publications created by the NPS community. Calhoun is named for Professor of Mathematics Guy K. Calhoun, NPS's first appointed -- and published -- scholarly author.

**Dudley Knox Library / Naval Postgraduate School**  
**411 Dyer Road / 1 University Circle**  
**Monterey, California USA 93943**

<http://www.nps.edu/library>

United States  
Naval Postgraduate School



THESIS

INVESTIGATION OF TEMPERATURE  
FLUCTUATIONS NEAR THE  
AIR-SEA INTERFACE

by

James Robert Ramzy  
and  
Ernest Tillson Young, Jr.

December 1968

Thesis  
R202

*This document has been approved for public re-  
lease and sale; its distribution is unlimited.*

INVESTIGATION OF TEMPERATURE  
FLUCTUATIONS NEAR THE  
AIR-SEA INTERFACE

by

James Robert Ramzy  
Commander, United States Navy  
B. S. , Naval Academy, 1954

and

Ernest Tillson Young, Jr.  
Lieutenant Commander, United States Navy  
B. S. , U. S. Merchant Marine Academy, 1959

Submitted in partial fulfillment of the  
requirements for the degree of  
MASTER OF SCIENCE IN OCEANOGRAPHY

from the

NAVAL POSTGRADUATE SCHOOL  
December 1968

Signature of Authors

*James R. Ramzy*  
*Ernest T. Young, Jr.*

Approved by

*Noel Boston*

Thesis Advisor

*Dale F. Rippon*

Chairman, Department of Oceanography

*P. J. Riechart*

Academic Dean

ABSTRACT

Measurements of air temperature fluctuations as close as 2.5 cm above the surface of a pond in the presence of wind generated waves were made. Fast response thermistors were used, one at constant absolute height and one mounted on a styrofoam float.

Data were collected on an Ampex CP-100 tape recorder using FM record amplifiers and a tape speed of 1 and 7.8 ips. The data were digitized by an SDS-9300 hybrid computer and analyzed by an IBM 360/67 digital computer.

Temperature fluctuations as large as 5°C, in as little as 0.2 seconds were observed with the float mounted thermistor.

There was strong correlation between the fixed and floating thermistor readings, with the fluctuation amplitude of the floating thermistor being more than three times larger than the fluctuation amplitude for the fixed thermistor. This ratio decreased when the height of the float mounted thermistor was raised.

Signal analysis revealed periodic components of temperature fluctuations associated with the wave action.

The large fluctuations measured by the floating thermistor are believed to be caused by the vertical motion of the thermistor in a large vertical temperature gradient immediately above the sea surface. More detailed instrumentation is needed to confirm this hypothesis.

TABLE OF CONTENTS

I.	INTRODUCTION -----	9
	A. BACKGROUND -----	9
	B. OBJECTIVES -----	10
	C. SITE -----	10
II.	EQUIPMENT -----	12
	A. TEMPERATURE -----	12
	1. The Physical Characteristics of Thermistors -----	12
	2. Thermistor Time Constant -----	12
	3. Thermistor Velocity Effect -----	15
	4. Thermistor Humidity Effect -----	17
	5. Result of Wetting Thermistor -----	17
	6. The Circuit -----	19
	7. Calibration of Thermistor Circuits -----	22
	B. WAVE GAUGE -----	25
	1. Theory -----	25
	2. The Probes -----	26
	3. The Circuit -----	26
	4. Wave Gauge Calibration -----	29
	C. WIND -----	29
	D. ARRANGEMENT OF SENSORS IN THE FIELD -----	29
III.	ANALYSIS -----	32
	A. GENERAL -----	32
	B. PREPARATIONS PRIOR TO "ANALOG TO DIGITAL" CONVERSION -----	32

C.	"ANALOG TO DIGITAL" CONVERSION -----	34
D.	ANALYSIS USING THE IBM 360/67 -----	39
IV.	DATA -----	42
A.	DESCRIPTION OF ENVIRONMENTAL CONDITIONS AND QUALITATIVE DISCUSSION OF RESULTS -----	42
1.	Run Number One -----	42
2.	Run Number Two -----	42
3.	Run Number Three -----	58
V.	CONCLUSIONS -----	81
VI.	RECOMMENDATIONS FOR FURTHER RESEARCH -----	82
	BIBLIOGRAPHY -----	84
	INITIAL DISTRIBUTION LIST -----	85
	FORM 1473 -----	87

## LIST OF FIGURES

1.	VECO 41A401C Micro-Bead Thermistor -----	13
2.	Wave Gauge Probes -----	13
3.	Time Constant Determination -----	14
4.	Velocity Effect -----	16
5.	Temperature Fluctuations in a Wind Tunnel -----	18
6.	Wet Thermistor Effect -----	18
7.	Thermistor Circuit -----	20
8.	Low Pass Filter Attenuation of Thermistor Circuit -----	21
9.	Phase Shift Resulting from L. P. Filter -----	23
10.	Typical Temperature Calibration Curves -----	24
11.	Wave Gauge Calibration -----	29
12.	Wave Gauge Circuit -----	28
13.	Sensor Arrangement -----	31
14.	Flow Chart, Method of Analysis -----	33
15.	Synchronous Clock -----	35
16.	Pre-Sampling Amplification and Filtering -----	37
17.	Timer -----	37
18.	Analog Computer L. P. Filter -----	38
19.	Temperature Record Run 1 -----	43
20.	Record of Data, Run 2 -----	45
21.	Power Spectrum Floating Thermistor 30 Oct. (Run 2) -----	48
22.	Power Spectrum Wave Gauge 30 Oct. -----	49
23.	Auto Correlation Float 30 Oct. -----	52
24.	Auto Correlation Fixed 30 Oct. -----	53

25.	Cross Correlation Float and Fixed 30 Oct. -----	54
26.	Auto Correlation Wave Gauge 30 Oct. -----	55
27.	Cross Correlation Float and Waves 30 Oct. -----	56
28.	Power Spectrum Fixed 30 Oct. -----	57
29.	Record of Data from Run 3 -----	60
30.	Vertical Profile of Mean Temperature -----	61
31.	Isotherm Model -----	62
32.	Power Spectrum Float 12 Nov (1) (Fist 1/2 of Run 3) -----	65
33.	Power Spectrum Fixed 12 Nov (1) -----	66
34.	Power Spectrum Wave Gauge 12 Nov (1) -----	67
35.	Auto Correlation Float 12 Nov (1) -----	68
36.	Auto Correlation Fixed 12 Nov (1) -----	69
37.	Auto Correlation Wave Gauge 12 Nov (1) -----	70
38.	Cross Correlation Float and Wave Gauge 12 Nov (1) -----	71
39.	Cross Correlation Float and Fixed 12 Nov (1) -----	72
40.	Power Spectrum Float 12 Nov (2) (Last 1/2 of Run 3) -----	73
41.	Power Spectrum Fixed 12 Nov (2) -----	74
42.	Power Spectrum Wave Gauge 12 Nov (2) -----	75
43.	Auto Correlation Float 12 Nov (2) -----	76
44.	Auto Correlation Fixed 12 Nov (2) -----	77
45.	Auto Correlation Wave Gauge 12 Nov (2) -----	78
46.	Cross Correlation Float and Wave Gauge 12 Nov (2) -----	79
47.	Cross Correlation Float and Fixed 12 Nov (2) -----	80

## ACKNOWLEDGEMENTS

The authors gratefully wish to express their appreciation for the fine guidance of their two thesis advisors, Dr. Theodore Green, III, and Professor Noel E. Boston. Dr. Green originally conceived the project; Professor Boston, with his experience in field research and his technical expertise was especially instrumental in helping us through some difficult problems.

Lieutenant Jerald Post, graduate student in the Electrical Engineering Curriculum, assisted in the digitizing of the analog data.

And finally, Dr. Carl Woehler, of the Physics Department faculty, contributed very greatly, with his sympathetic and neighborly interest, as well as with his valuable advice.

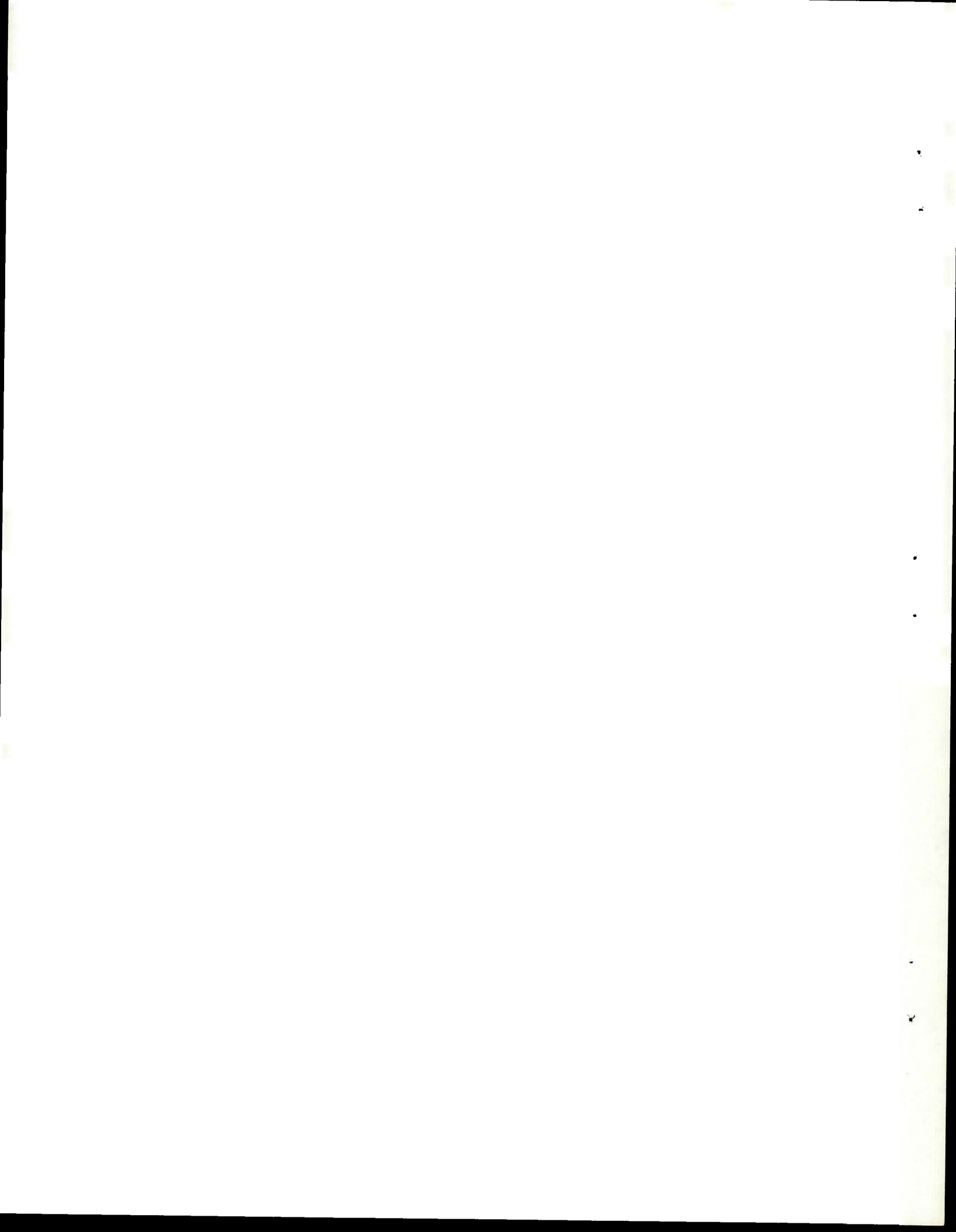

## I. INTRODUCTION

### A. BACKGROUND

The heat which passes to the atmosphere through the surface of the ocean probably provides the principal source of energy for atmospheric motion. This systematic flow of heat to the air exerts a controlling influence on the development of ocean storms and air circulation, yet most forecasting models must ignore the action at the sea-air interface because there is neither the basic understanding of the processes involved nor sufficient observational information. Clearly the importance of air-sea interaction lies in terms of the large scale dynamic processes influencing the weather, but in order to understand the macro-processes, it is first necessary to understand the microprocesses occurring at the air-sea interface. This study is an attempt to look into one narrow aspect of this relatively unexplored domain, namely, the temperature field immediately above the sea surface.

Such studies yield information on the magnitude of temperature fluctuations near the sea surface, the gradient of temperature above the surface and an indication of turbulence very near the waves. Further, the development of instrumentation to make these measurements is necessary before direct measurement of heat flux can be made by the eddy correlation method:

$$H = \rho C_p \overline{w\theta} \quad (1)$$

where  $\rho$  is the air density,  $C_p$  is the specific heat of air at constant pressure,  $W$  is the fluctuating vertical component of velocity and  $\theta$  represents fluctuations of temperature about a mean. The flux thus obtained can be compared with estimates from empirical relations based on profile measurements which in turn could provide clues on how to parameterize transfer equations to be of maximum use in oceanographic and meteorological forecasting.

These measurements provide some of the information needed to link the atmosphere-ocean exchanges.

#### B. OBJECTIVES

This study has as its objectives:

1. The development of devices to measure temperature as near as possible to the surface of a wave, and the associated wave height.
2. The collection of this data in a form suitable for analog or digital statistical analysis.
3. A statistical analysis to determine possible correlations between air temperature fluctuations and wave height.

#### C. SITE

The observations reported here were obtained at Roberts Lake in Seaside, California. The measurement site was about 35 feet from the shore in 4.5 feet of water. Reeds growing along the shore absorbed incident wave energy preventing reflections. Wind fetch was about 200 feet for each run analyzed. Data collections were made at three wind speeds:

1. Calm to very light and variable winds for purposes of comparison with data collected at higher wind speeds.
2. Light winds, 2 to 4 meters per sec.
3. Higher winds, 7 meters per sec.

## II. EQUIPMENT

### A. TEMPERATURE

Temperature measurements were made using Victory Engineering Co. model 41A401C micro-bead Thermistors (Figure 1).

1. The physical characteristics of these thermistors are:

- a. Bead diameter: .005 in.
- b. Lead diameter: .0007 in.
- c. Resistance at 25°C: 10,000 ohms
- d. Resistance change: -3.6%/°C at 25°C

As specified by the manufacturer and experimentally verified by the authors, the resistance change can be considered linear for the range of temperature change encountered.

- e. Time constant in dry air 0.1 sec. ± 10% as advertised by vendor
- f. Time constant in humid air .0505 sec. as determined experimentally

### 2. Thermistor Time Constant

Thirty tests were made of thermistor time constants. A thermistor was mounted on a rod which was inserted into a heated compartment and accelerated clear by a rubber band (Figure 3). The time constant was determined from the time required for the thermistor to decrease from its initial temperature to 63% of its final temperature. The thirty

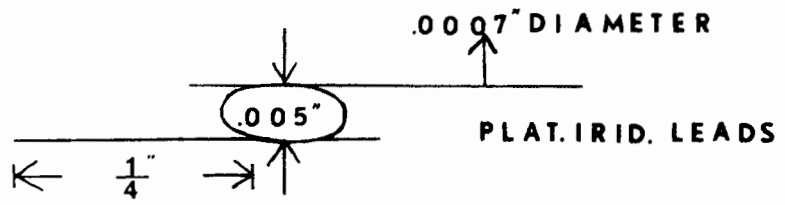

Figure 1. VECO 41A401C Micro-Bead Thermistor

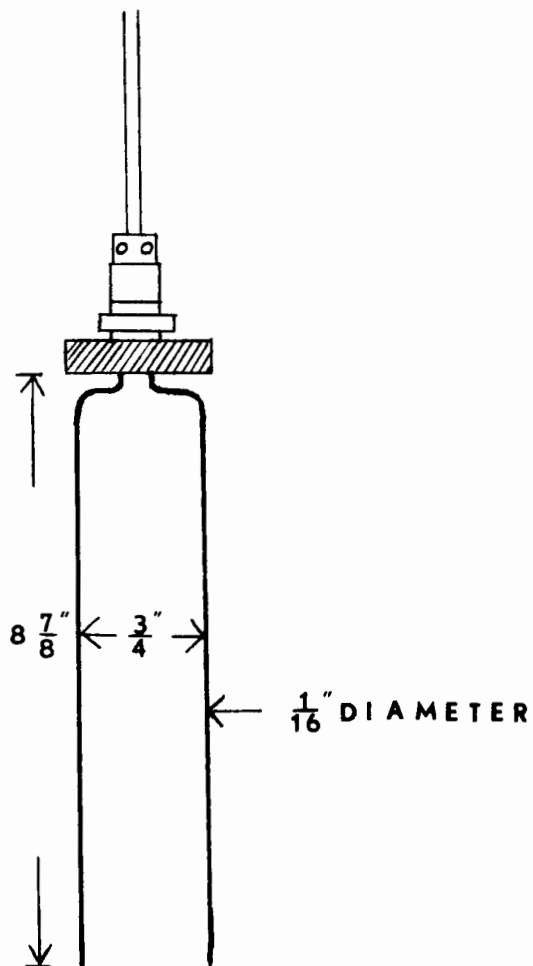

Figure 2. Wave Gauge Probes

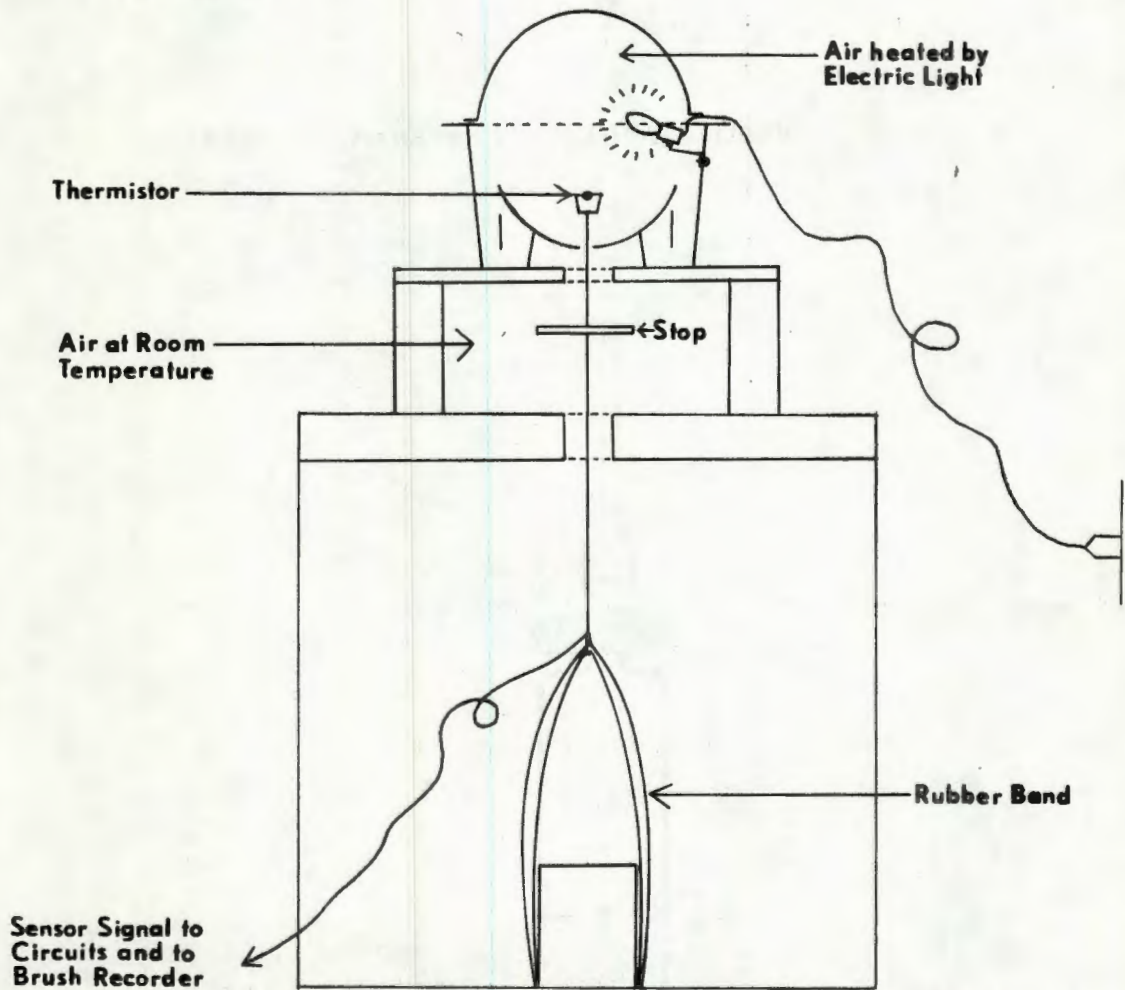

Figure 3. Time Constant Determination

tests gave a time constant of .0505 seconds with a standard deviation of 0.009.

These results are biased by the finite time required for the sensor to move into the new environment and by the amount of temperature change in the rod. Qualitatively, oscillations with frequencies greater than 20 Hz are observed on the record (with no estimates, of course, of what percent of the actual change is recorded).

### 3. Thermistor Velocity Effect

When using thermistors to measure temperature in a moving fluid, the electrical current applied must be low or power will dissipate in the bead as heat and mask the desired temperature of the environment. Flow past the bead will remove this heat at a rate proportional to fluid velocity. This is called "velocity effect." With 0.2V applied to the thermistor bridge, calculations indicate power dissipated in the bead is about 1 microwatt. No velocity effect is theoretically expected at this power level [Rasmussen 1961]. Nevertheless tests of the effects of wind velocity on indicated temperatures were made using a portable wind tunnel. These tests (Figure 4) show there was no change in indicated temperature for winds from 0 to 8 meters/sec so that velocity effect is indeed negligible.

Tests of this nature are extremely difficult to accurately perform without the necessary sophistication in equipment and method. The uncontrollable and undesirable environmental changes encountered, such as actual room

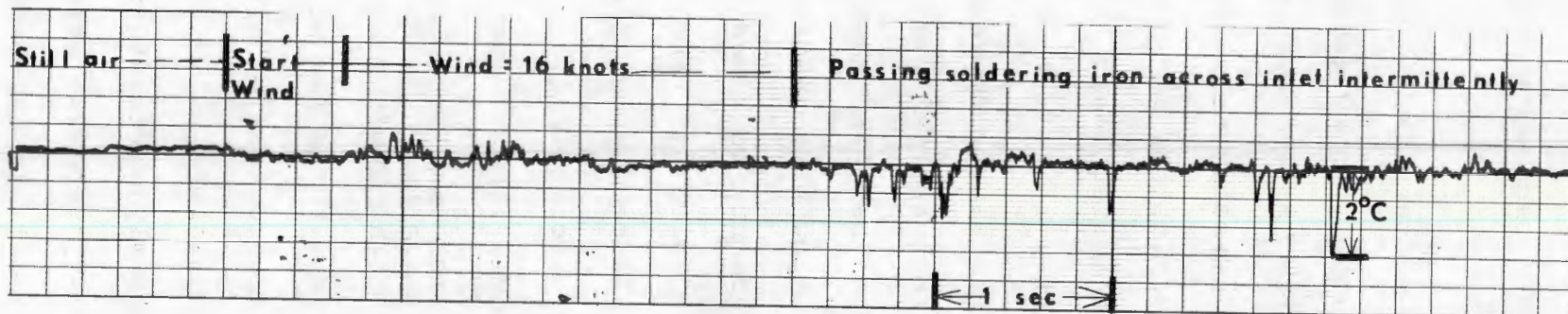

Figure 4. Velocity Effect

Recording of wind tunnel test showing absence of velocity effect.

The record shows:

1. Zero wind velocity. Thermistor indicating ambient temperature.
2. Wind tunnel fan energized. Air velocity 4.5 M/sec. The indicated mean temperature remains constant.
3. Temperature spikes caused by passing a warm soldering iron rapidly across the tunnel entrance. The rapid response to temperature changes is easily seen.

temperature changes and turbulence (Figure 5), can only yield an indication of the expected or desired information.

#### 4. Thermistor Humidity Effect

A change in air humidity will affect the thermistor in the same way as wind velocity; an increase in either quantity will give an increase in the effective heat capacity of the air. Thus the absence of a velocity effect implies the absence of a humidity effect.

#### 5. Result of Wetting the Thermistor

A false reading will result if the thermistor becomes wetted with water. The evaporation of water clinging to the bead will cool it until the water has completely evaporated. Figure 6 shows the result of spraying demineralized water into the inlet of the portable wind tunnel containing a thermistor (air velocity was 4.5 meters/sec.). The quantity of water mist necessary to cause the effect shown was "large" in each case and was visible to the eye as it entered the air stream. Attempts to generate this quick and large negative temperature change with this gradual return using "smaller" bursts were unsuccessful. No quantitative results can be deduced from this test except that changes as great as  $-2^{\circ}\text{C}$  may be caused by passages of very moist air. The test was designed to ensure recognition of similar events in the record of actual data if they occurred.

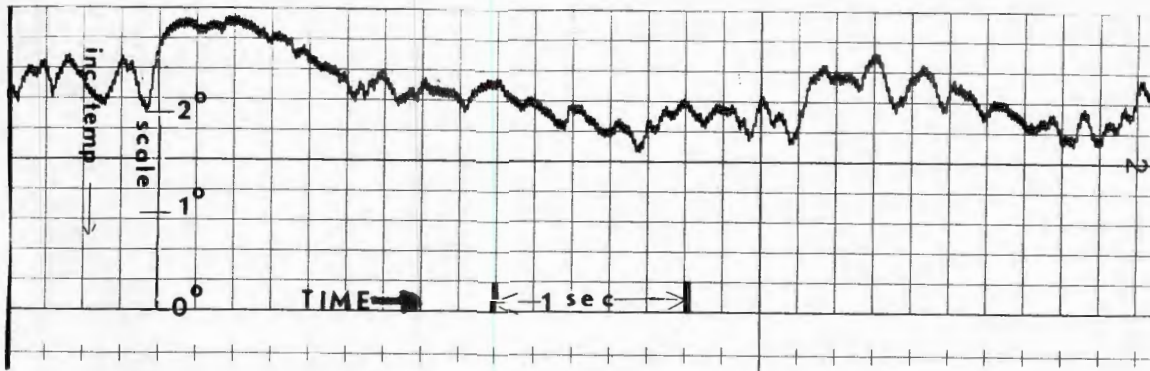

Figure 5. Temperature Record Showing Magnitude and Character of Temperature Fluctuations in the Wind Tunnel

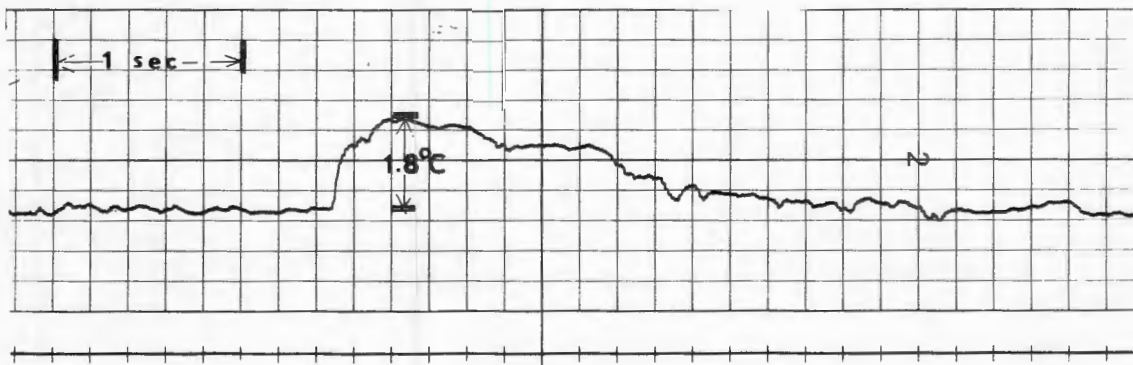

Figure 6. Recording of Wind Tunnel Test Showing Effect of Spraying a Mist of Water Into the Tunnel Inlet. Air Velocity was 4.5 M/Sec

## 6. The Circuit

The thermistor formed one arm of a wheatstone bridge (Figure 7) powered by a 1.3 volt mercury battery. To minimize current through the thermistor, resistor R1 is adjusted so that the applied voltage is 0.2 volts. The thermistor resistance at a known temperature is balanced (nulled) by resistors R2 and R3. A simple low pass filter (R4 and C1) was used to reduce undesirable high frequency noise. Their values were chosen to attenuate a 40 cycle signal by 3 db. Higher frequencies will be attenuated at 6 db/octave according to the formula

$$\frac{E}{E_0} = \frac{1}{R + \frac{1}{i\omega C}} \quad (2)$$

where

$$\frac{E}{E_0} = \text{voltage attenuation}$$

$$R = \text{filter resistance signal}$$

$$\omega = \text{signal angular frequency}$$

$$C = \text{capacitance in microfarad}$$

Figure 8 shows the filter attenuation characteristics. An undesirable effect of this filter is that all frequencies are phase shifted by an amount  $\theta$ :

$$\text{phase shift } (\theta) = \text{Tan}^{-1} (R\omega C) \quad (3)$$

It follows that a signal of frequency 20 cycles/sec is shifted by about 20 degrees; a 10 cycle signal

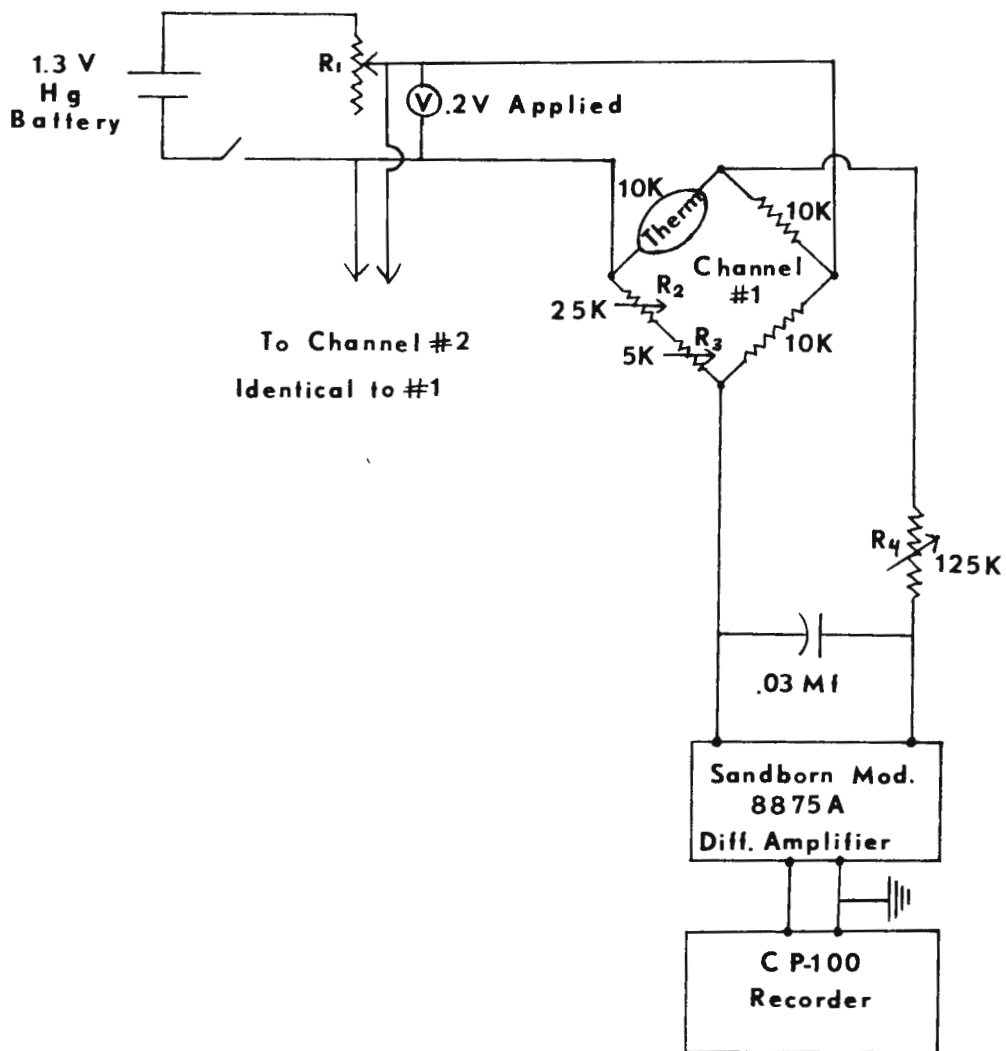

Figure 7. Thermistor Circuit

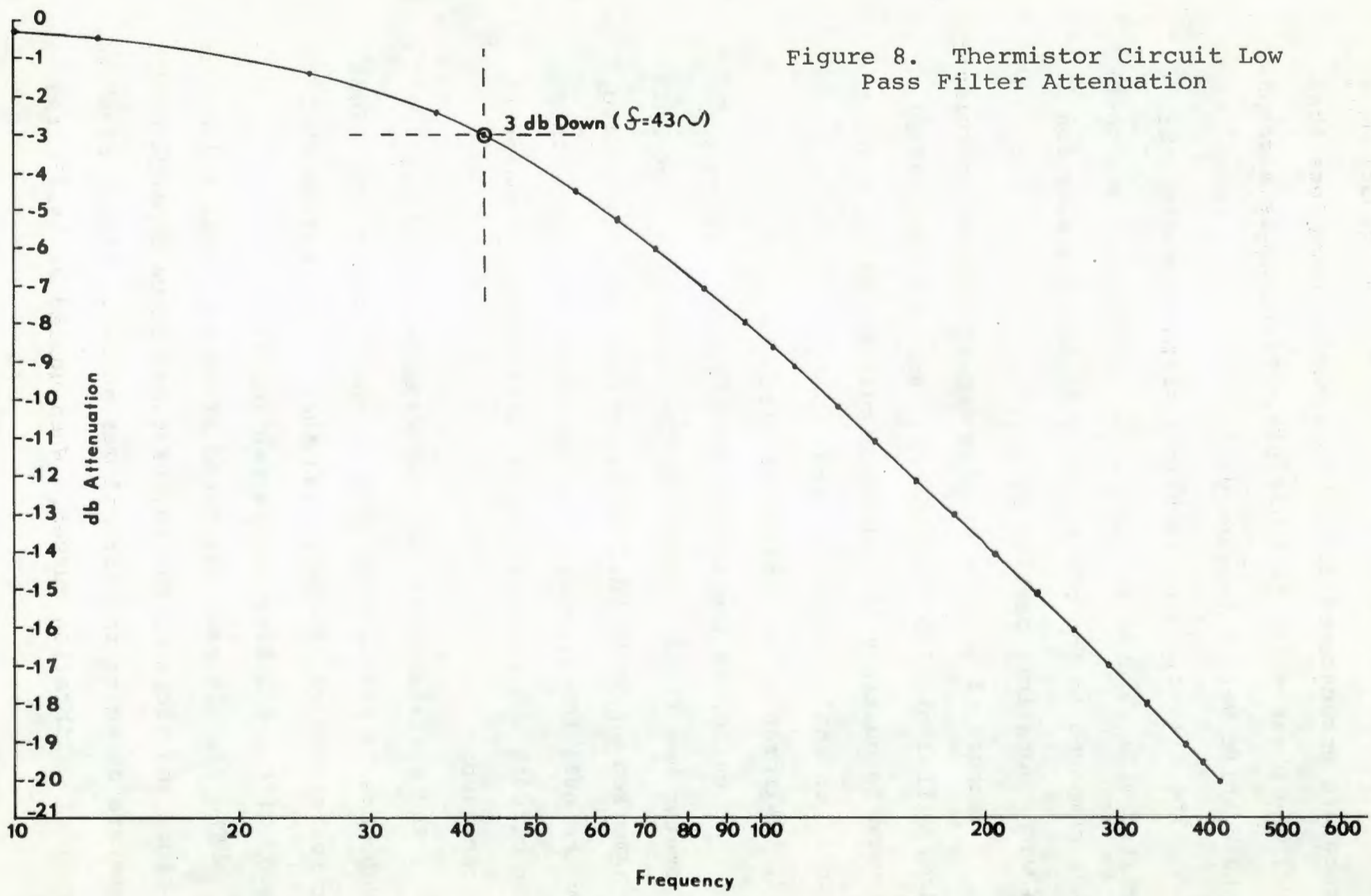

Figure 8. Thermistor Circuit Low Pass Filter Attenuation

approximately 10 degrees, etc. Since most fluctuations in temperature encountered are of frequencies much less than 20 Hz, the phase shift is tolerable. Figure 9 is a graph of phase shift versus frequency.

The filter, being identical for both thermistor circuits, will have no effect on the response of one thermistor compared to the other. Only in their comparison with waves does this problem arise.

Because of the low voltage applied to the thermistor bridge, differential DC amplifiers (Sanborn Model 8875A) were used to multiply the output signal by 100 in order to record it on analog magnetic tape.

#### 7. Calibration of Thermistor Circuits

To calibrate the thermistor circuit, a mercury thermometer was fixed adjacent to the thermistor, and both were immersed in demineralized water that had been cooled below the null temperature. As the water warmed up, thermistor circuit out-put voltage and thermometer temperature were recorded.

The resistance of the demineralized water was 185,000 ohms as measured by pins one-half inch apart. Thus water resistance was large enough that its effect on the accuracy of the calibration was negligible.

The circuit was calibrated after each data collection run, since the slope of the calibrations curve depends on the temperature at which the circuit was nulled. Figure 10 shows two typical calibration curves. When nulled at 16.7°C the

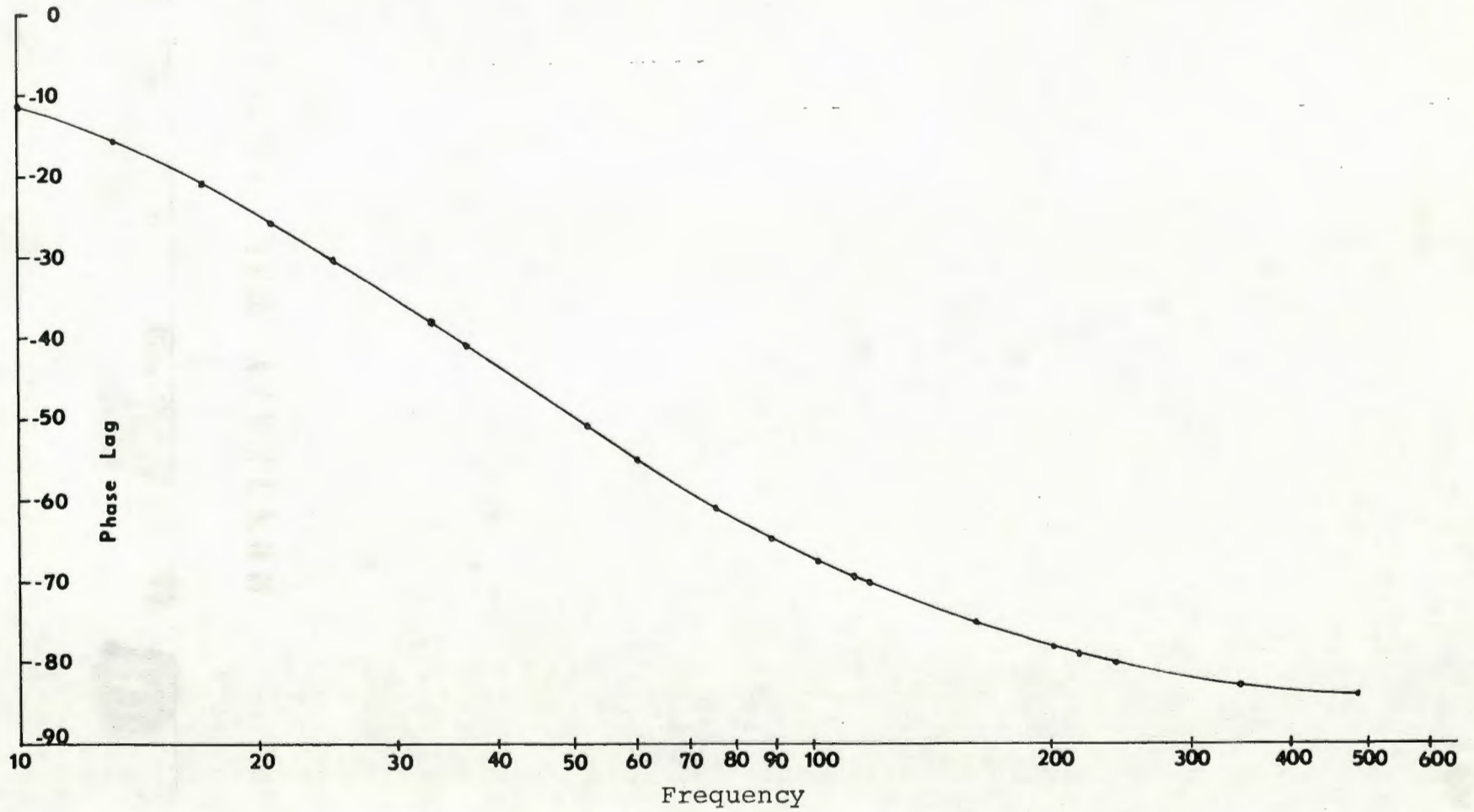

Figure 9. Phase Shift Resulting from Low Pass Filter

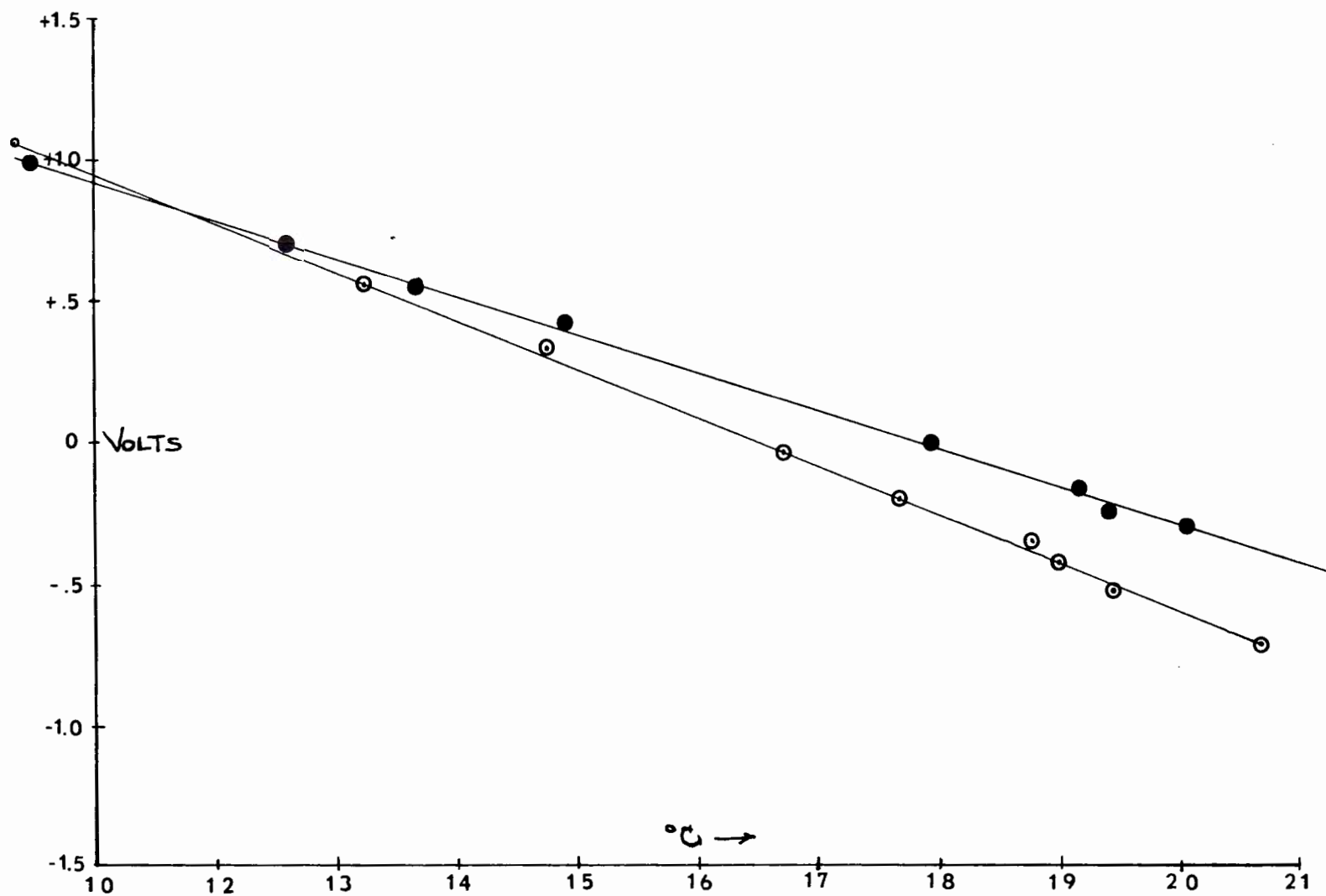

Figure 10. Typical Temperature Calibration Curves

slope is .167 volts/°C; while when nulled at 17.92°C the slope is 0.151 volts/°C. This is due to the resistance change per degree characteristic of the thermistor used.

The temperature measurement circuit is linear for a range greater than ± 6°C about the null temperature. This was verified by several laboratory tests.

Many calibrations using different thermistors proved that calibrations at a given temperature could be repeated with a high degree of accuracy.

## B. WAVE GAUGE

### 1. Theory

When electrical probes of low resistance are immersed in water the resistance of the water path between them varies empirically as [Pearlman]:

$$R = \frac{KD \cdot 12}{dL}$$

R = net resistance of wire and water path

K = a measure of conductivity (about 600 ohm-in<sup>2</sup> as calculated for Roberts Lake)

D = distance between wires (inches)

L = depth of immersion of probes (inches)

d = wire diameter (inches)

A resistance wave gauge of this type, when deeply immersed, becomes non-linear due to transmission line loss [Farmer, 1961], since after a limiting amount of probe wire is under water its own resistance becomes appreciable. As

shown in Figure 11, the probes developed for this research give linear results over the first seven centimeters.

## 2. The Probes

Silbraze rods were selected as the probe material because of its low resistance, availability in fairly small diameter, and its stiffness. Stiffness was desired for the probes to eliminate the necessity of support which would cause interference underwater. A previously used device had supports which inserted an unacceptable capacitance into the circuit. Figure 2 is a sketch of the wave gauge probes.

## 3. The Circuit

Power for the wave gauge circuit was provided by a Hewlett Packard Model 200 AB audio oscillator set at a frequency of 2kHz. Voltage was adjusted to give the desired signal amplitude for whatever wave height existed at the time. It was generally found that the higher voltages recorded and reproduced more effectively on the CP-100 tape recorder. Figure 12 is a schematic of the wave gauge circuit. The variation in resistance of the wave gauge with wave height controls the balance of the wheatstone bridge. The variable resistor R1 is used to null the bridge circuit prior to a run.

The transformer is necessary to provide isolation of the bridge, which is grounded at one leg, from the tape recorder input which is also grounded.

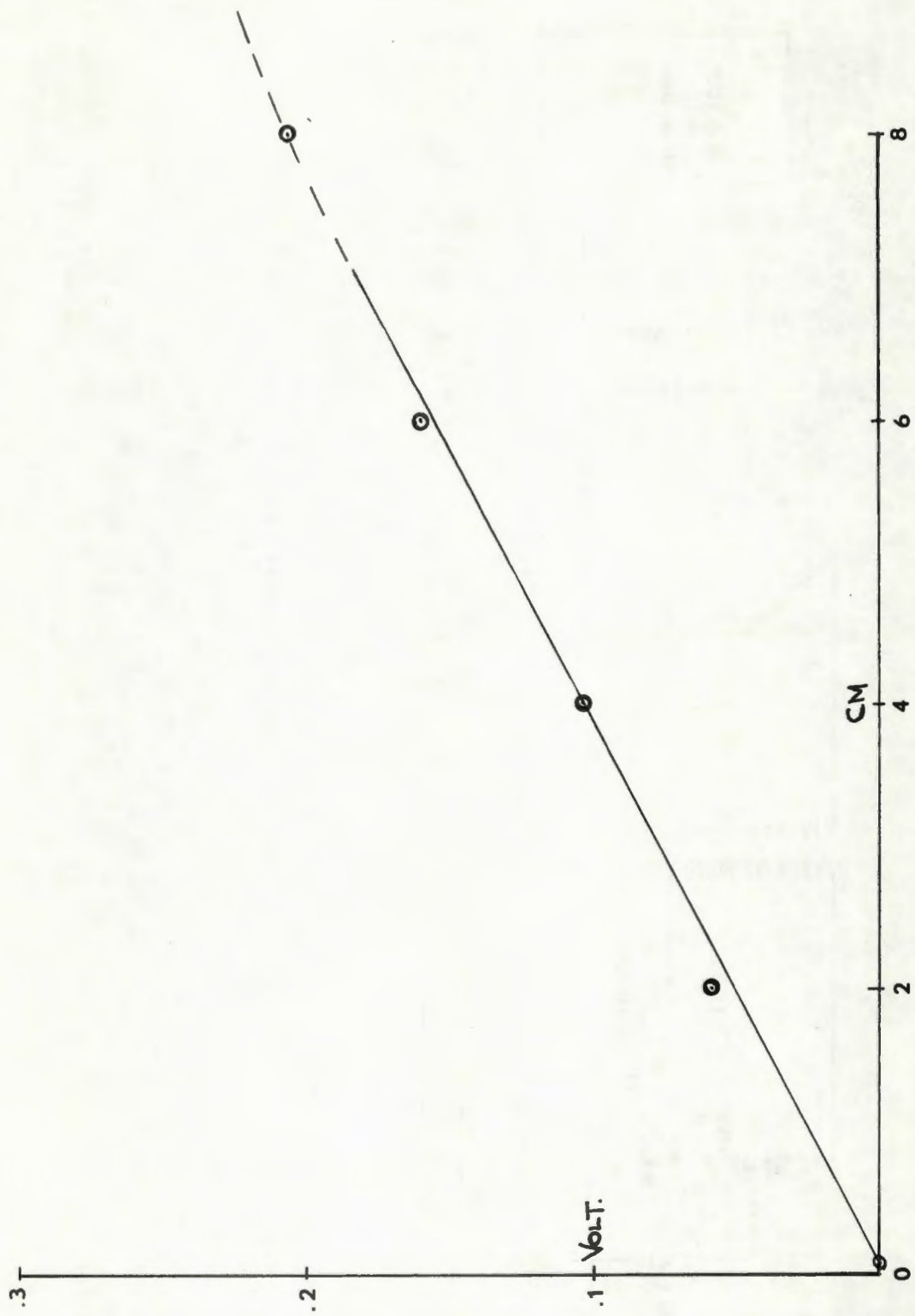

Figure 11. Wave Gauge Calibration

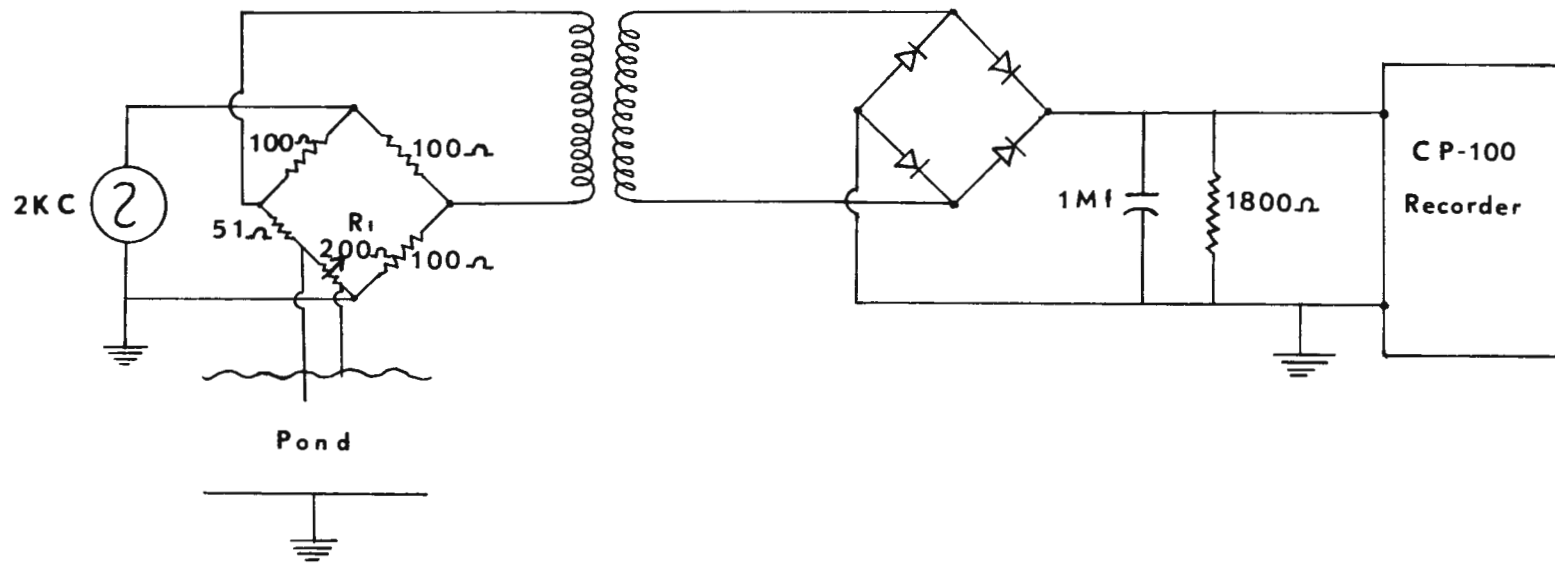

Figure 12. Wave Gauge Circuit

#### 4. Wave Gauge Calibration

The gauge was statically calibrated in lake water, using a sheltered lee close to the shore, prior to each run. With the probes barely immersed, the bridge was nulled. Then circuit output voltage versus probe immersion was recorded in 2 cm steps. Figure 11 is a typical wave gauge calibration curve.

#### C. WIND

Mean wind was monitored by a Casella cup anemometer, model 2056/C, bolted to the frame.

#### D. ARRANGEMENT OF SENSORS IN THE FIELD

A C-shaped arrangement of pipes served as a chasis to which all sensors were mounted. In preparation for a run the device was slipped over a steel stake driven into the bottom of the pond. It was then oriented to properly position all sensors, (Figure 13) and secured with locking nuts.

The floating thermistor was mounted on a styrofoam hemisphere shaped float, which followed the vertical wave motion along a stretched wire. The height of this thermistor above the surface could be adjusted from 5.5 cm to 2.0 cm above the moving water surface.

A second thermistor, mounted on a steel rod, was placed at constant absolute height for each run. The wave gauge was clamped to the frame so as to be as near as possible

Figure 13. Sensor Arrangement

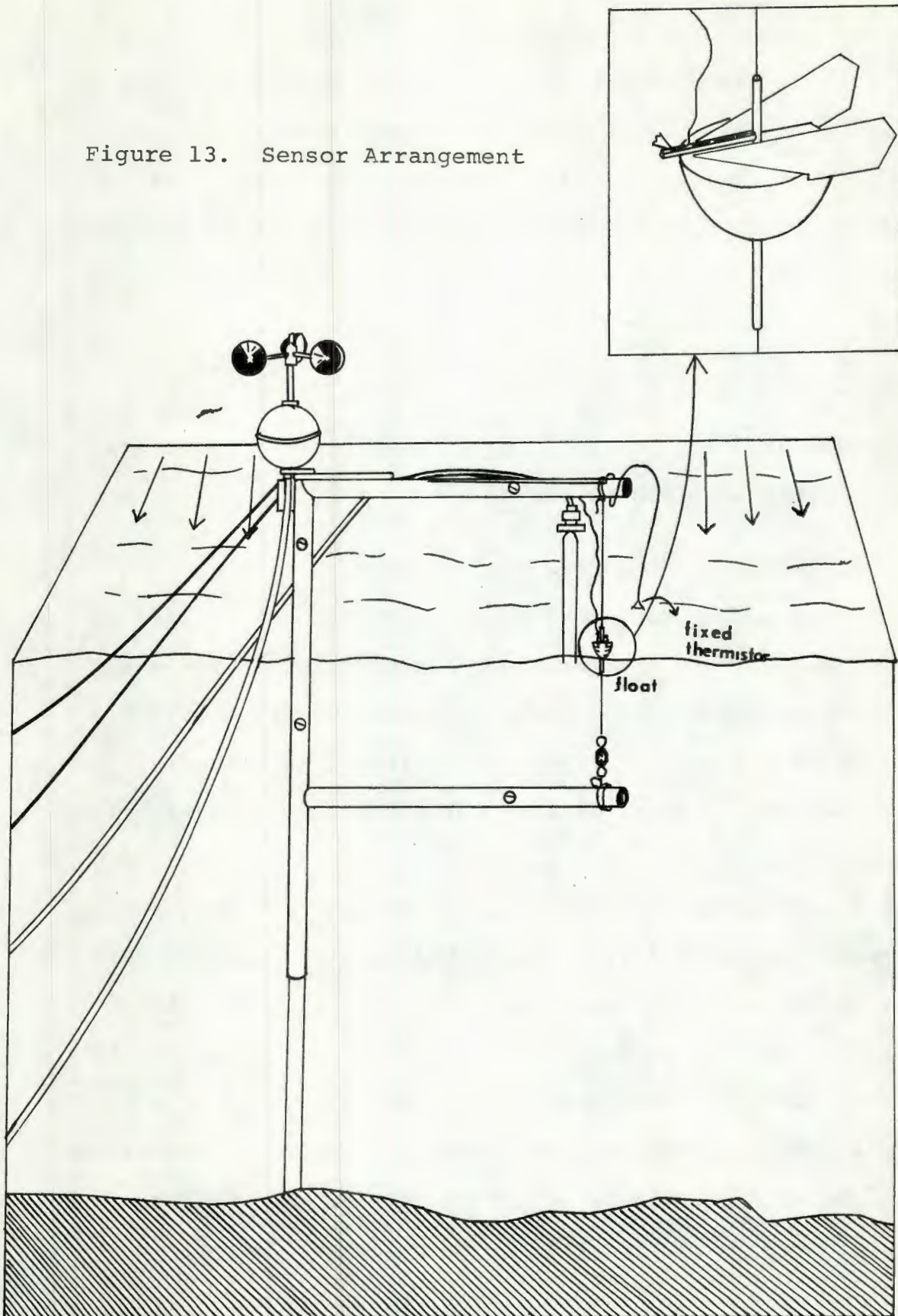

to the thermistors, and mounted in a line with them along the wave crests.

The Casella anemometer was bolted to the frame, at a height of about 3 ft. above the surface of the water.

### III. ANALYSIS

#### A. GENERAL

1. The analog data recorded on the CP-100 FM tape recorder was digitized by use of an SDS-9300 hybrid computer.

2. Core space limitations (24K) of the digital component of the SDS-9300 greatly hamper its use for stochastic analysis of all but the simplest parameters. It was therefore necessary to analyze the data using the IBM 360/67. The two machines are not compatible, and a transformation of the digitized data was necessary prior to its use with the IBM complex. A general flow of the analization process is shown in Figure 14.

#### B. PREPARATIONS PRIOR TO "ANALOG TO DIGITAL" CONVERSION

1. The 3 sets of recorded data were reproduced for visual pre-analysis editing on a strip chart recorder. Because the CP-100 was not used to record field calibration, this strip record was necessary to convert the voltage fluctuation to temperature and wave height.

2. Upon visual inspection, and to achieve the desired results within practical considerations, the following parameters were set for each of the 3 runs: (consisting of the 3 sensors)

$$\text{Nyquist frequency } F_c = \frac{1}{2DT} = 64 \text{ Hertz}$$

DT = time interval between samples

length of record, Tr = 64 sec.

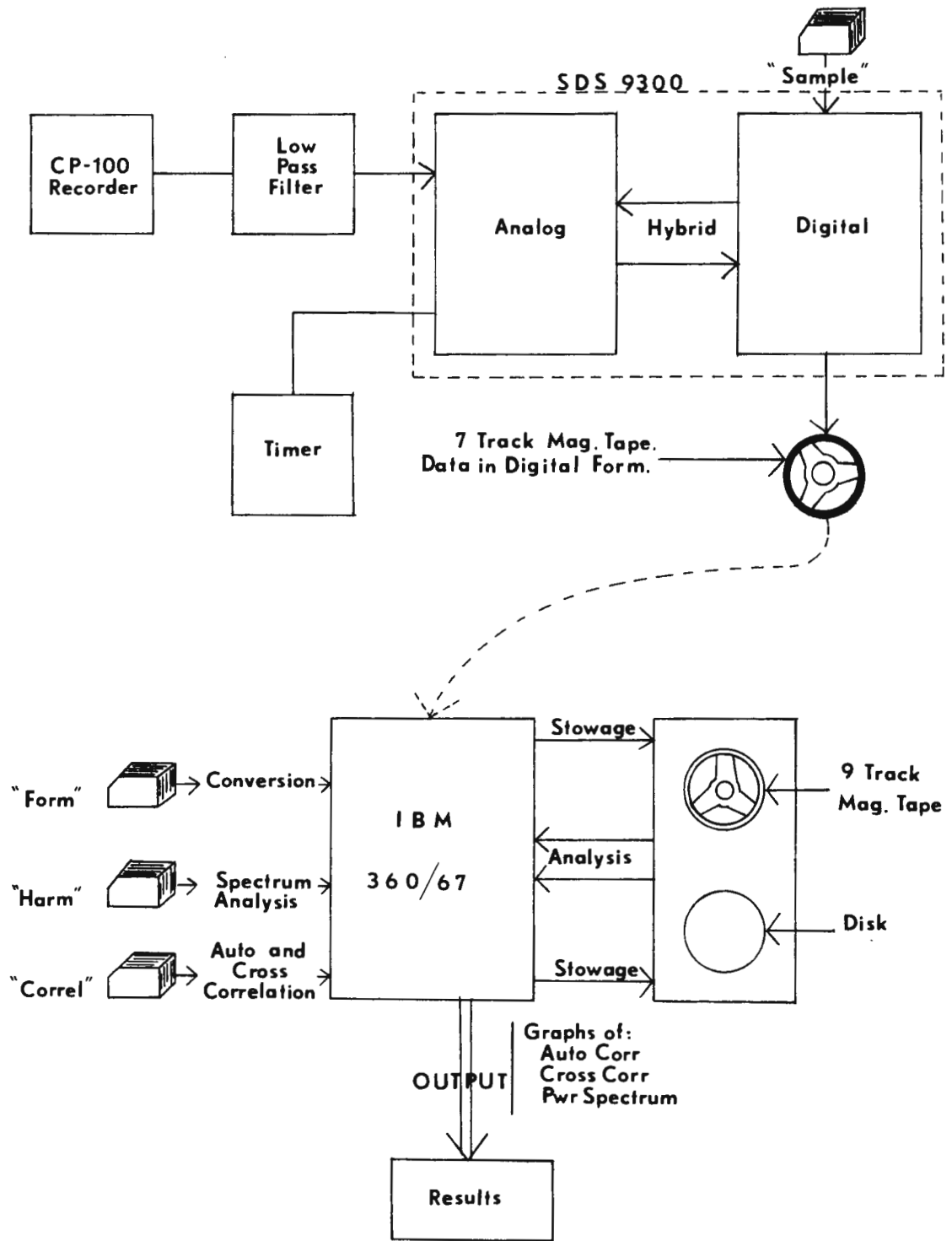

Figure 14. Flow Chart, Method of Analysis

The sampling rate ( $2F_c$ ) is required by subroutine "Sample" to be a power of 2. Other considerations were the measured response of the thermistor bead, the desire to use at least a 60 sec sample for some measure of stability of spectral estimates, and the 350K core limitation for the IBM 360/67.

These set parameters established the following characteristics:

Sample size  $N = 8192$

Bandwidth (max) =  $\frac{1}{2DT} = 64$  Hertz

Delta frequency =  $\frac{1}{N(DT)} = \frac{1}{64}$  Hertz

Max lag (for correlation)  $m = 890$

3. To accurately determine the correlation functions, sampling had to commence at exactly the same position on the tape for the 2 appropriate records. To achieve this, a 100 Hertz signal was recorded for the 60 second period preceeding the desired segment of tape to be digitized. The loss of this signal was used with the synchronous clock constructed on the analog computer (Figure 15), to place the "hybrid" in the compute mode of operation.

#### C. "ANALOG TO DIGITAL" CONVERSION

1. There were two routes available to the authors for the actual A to D conversion. One was to use an existing SDS-9300 subprogram called "ADK." It has the capability of digitizing two records simultaneously (eliminating the need of the start mechanism described earlier), and is written in

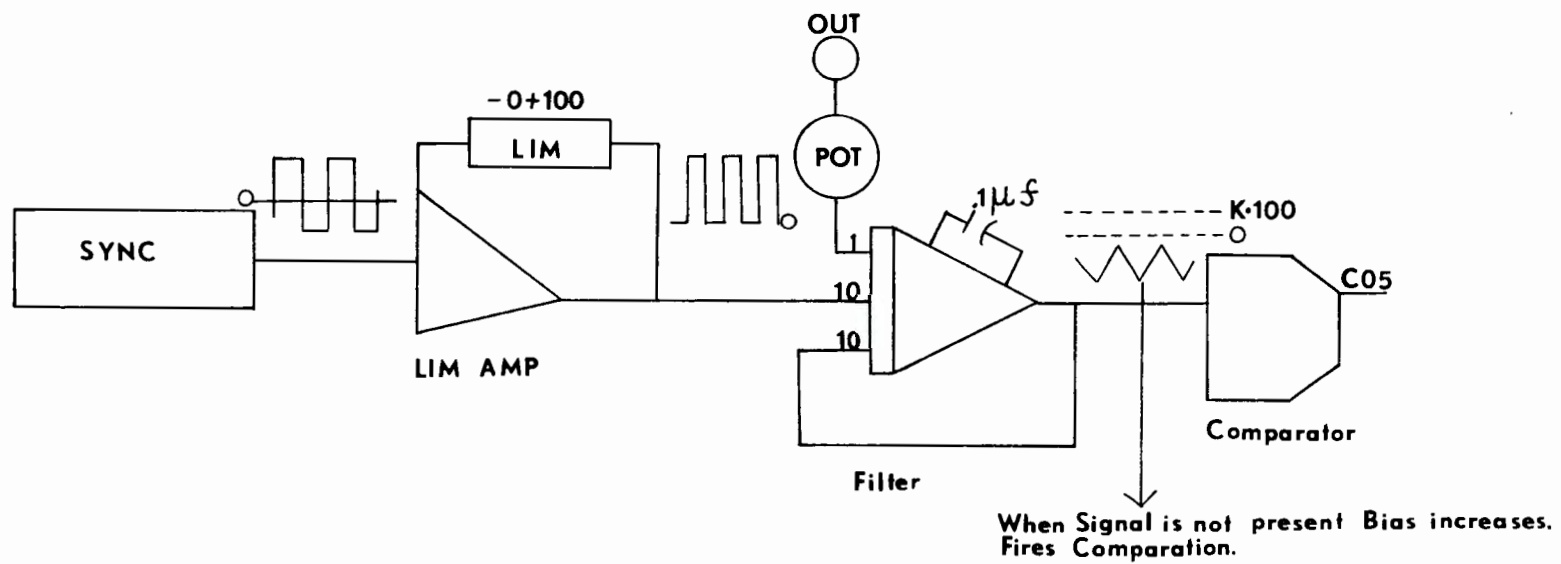

Figure 15. Synchronous Clock

fortran language. The alternate, and the one used, is subroutine "SAMPLE" [Post, 1968]. It is written in machine language, is more versatile, and saves a considerable amount of machine space compared to ADK. Although the capability did not exist for digitizing more than one channel at a time, a revision is presently being written which will allow 4 channel consecutive digitizing.

2. The maximum frequency recorded was in the neighborhood of 60 Hertz. The signal coming from the CP-100, after amplification by a factor of 50, was filtered of higher frequencies to prevent aliasing (Figure 16). A low pass filter was used on the analog computer which has the characteristics shown in Figure 18.

3. There is a timer on the analog computer that allows selection of sampling rates of 1000, 100 and 10 per second. Because SAMPLE (and "HARM" of the IBM 360, described later) requires sampling at the rate of a power of 2, an accurate sine wave generator was used in conjunction with the program to sample on all zero crossings at the rate of 128 per second. A double buffering system consisting of 128 word lengths is used to store the sampled data on 7 track magnetic tape.

4. On completion of digitizing, selected blocks of data (128 datum points per block) were converted and printed as real data so that a check would be made after conversion on the IBM 360.

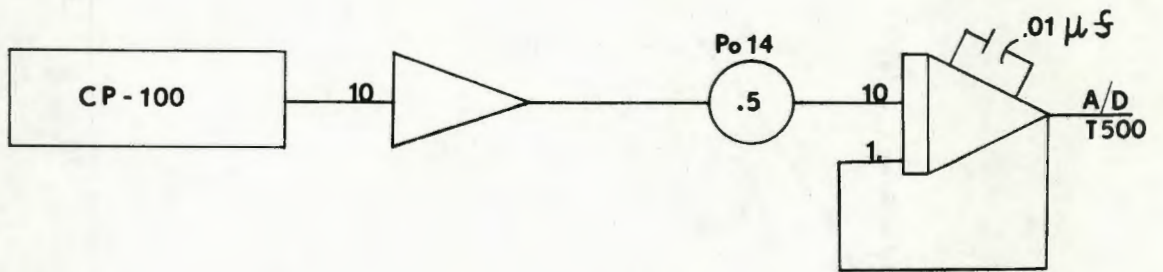

Figure 16. Pre-Sampling Amplification and Filtering

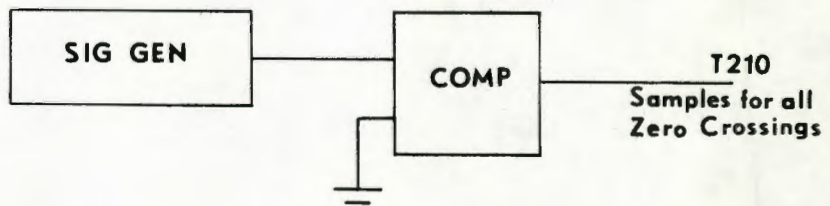

Figure 17. Timer

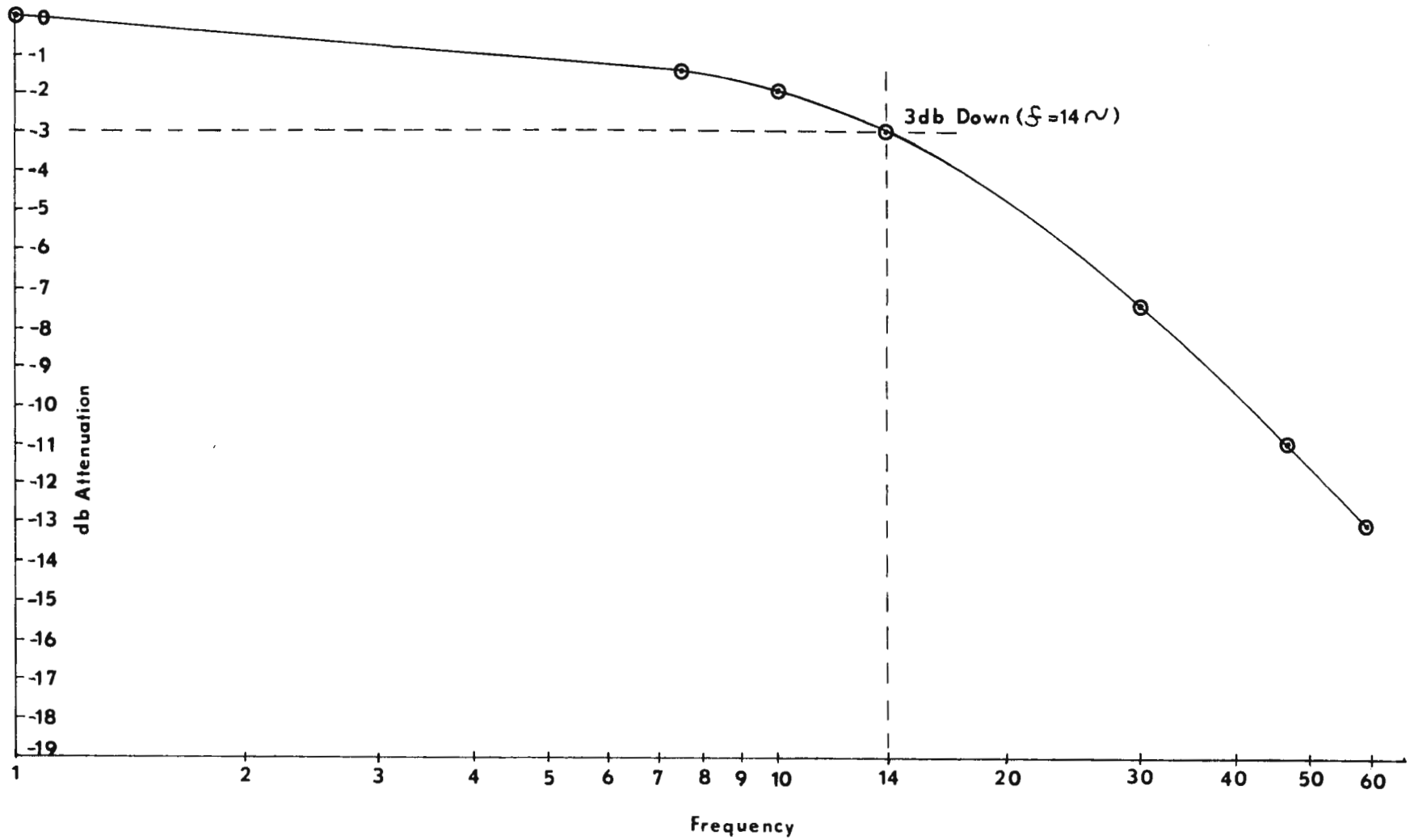

Figure 18. Analog Computer L. P. Filter Atten

#### D. ANALYSIS USING THE IBM 360/67

1. Because of the non-compatibility of the two computer systems, it was first necessary to convert the data and restow it on 9 track magnetic tape and/or on a disk for later recall.

a. The non-compatibility is a result of the SDS-9300 having a basic word length of 24 bits and the IBM 360 a basic word length of 32 bits. Subprogram "FORM" [Post, 1967] makes this conversion and simultaneously changes the data from binary to BCD floating point real numbers prior to restowage. Data print out was also used at this time to check for proper conversion, comparing against the data previously produced.

2. Much time was required to make this conversion, resulting from the inability of the IBM system to consistently read the 7 track tape. Blocks of data were randomly skipped or repeated and although this could be acceptable if consistently repeatable, its randomness would make any attempt of correlation analysis impossible. A successful conversion to 9 track tape and a disk was finally accomplished and a print out of all 81,000 data points was made to establish complete continuity.

3. Autocorrelation, defined by

$$R_X(\tau) = \lim_{T \rightarrow \infty} \frac{1}{T} \int_0^T N(t)N(t+\tau)dt \quad (4)$$

was solved in its finite general form of

$$R(r) = \frac{1}{N-r} \sum_{n=1}^{n-r} x_n x_{n+r} \quad , \quad r = 0, \dots, m$$

where uniquely for our data  $N = 8192$  and  $m = 890$ , which supplies time lag information to approximately 7 seconds. To use computer graph capability, all data sets were initially reduced to a zero mean, which essentially removes the DC bias. This also facilitates use of the autocorrelogram to show the relative general intensity of the data in rudimentary terms, by its mean square value calculated when TAU equals zero.

Because of the zero mean, and the relation

$$\sigma_N^2 = \psi^2 - \mu_N^2, \quad (6)$$

the variance is also given directly on the autocorrelogram.

4. Cross-Correlation, defined by

$$R_{Ny}(\tau) = \lim_{T \rightarrow \infty} \frac{1}{T} \int_0^T x(t)y(t+\tau)dt \quad (7)$$

was solved in its finite general form of

$$R_{Ny}(r) = \frac{1}{N-n} \sum_{n=1}^{N-n} x_n y_{n+r} \quad , \quad r = 0, 1, 2, \dots, m \quad (8)$$

where for our specific case  $N = 8192$  and  $m = 890$  again giving a time lag up to approximately 7 seconds.

The cross correlation was normalized to give values between plus and minus one by dividing them by the autocorrelation function at tau equal to zero for the two

samples involved. This defines a sample cross correlation coefficient of

$$\rho_{NY}(r) = \frac{R_{ny}(r)}{\sqrt{R_N(0)} \sqrt{R_{Ny}(0)}} \quad (9)$$

which should satisfy

$$-1 \leq \rho_{NY}(r) \leq 1$$

5. Power spectra were calculated by use of the IBM 360 library subroutine HARM which performs discrete complex Fourier transforms on a complex 3 dimensional array by using the fast Fourier transform technique. A simplified general form of the equation solved is

$$S(f_n) = \Delta t \sum_{K=0}^{N-1} x(t_k) e^{-j2\pi f_n t_k}, \quad n = 0, 1, \dots, \pm \frac{N}{2} \quad (10)$$

The benefit in using the fast Fourier transform is the great computational efficiency in determining the Fourier coefficients of a given series. As mentioned earlier, the subroutine requires  $2^n$  data points which for simplicity in operation should be considered in the A to D process, along with the large memory requirements also stipulated.

#### IV. DATA

##### A. DESCRIPTION OF ENVIRONMENTAL CONDITIONS AND QUALITATIVE DISCUSSION OF RESULTS

###### 1. Run Number One

This run was conducted primarily to determine instrument response in low winds, so that a representative spectrum of environmental conditions would be obtained. The data collected during this run was not analyzed statistically. Figure 19 is a segment of the recorded data from the floating thermistor.

The calm wind condition was periodically interrupted by gentle gusts with almost immediate small wave generation.

This record provides an interesting comparison with data collected during stronger winds with larger waves (Figures 20 and 29).

###### 2. Run Number Two

For this run the floating thermistor was positioned to travel 2.5 cm above the wave surface. The fixed thermistor was approximately 2 cm higher than the floating sensor during passage of the highest waves, and with respect to the wave fronts, about 6.5 cm behind it.

Mean wind velocity for this run was 2.75 meters/sec. and water temperature at a depth of three cm was 17.74°C. The wave record indicates a predominant wave frequency of 2.1 Hz. The highest wave in each group was approximately 2.7 cm.

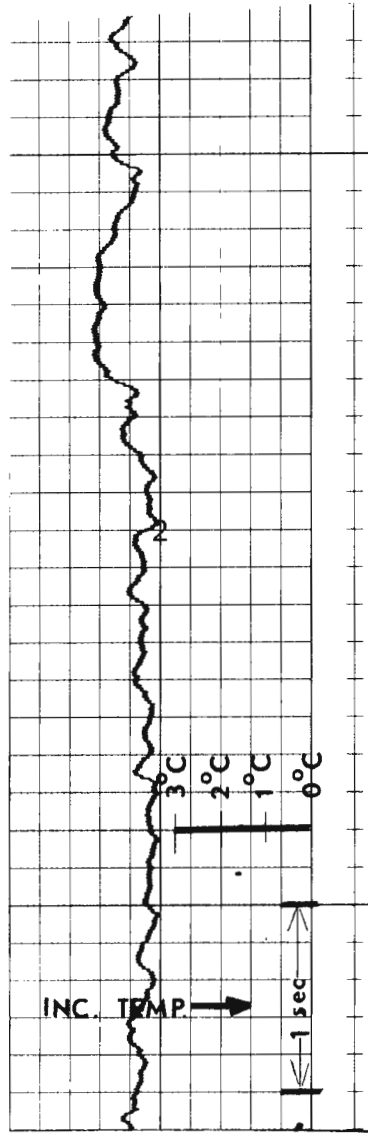

Figure 19. Temperature Record Run 1

Figure 20, a representative portion of the data recorded on the CP-100 FM tape recorder, shows floating and fixed thermistor temperature fluctuations with their corresponding wave record.

The following features are apparent on direct observation of the record:

a. The floating thermistor frequently exhibits negative temperature "spikes" with peak to peak amplitudes of approximately five centigrade degrees, occurring within 0.2 seconds.

b. These large spikes could be related to the passage of the maximum wave height in each wave group. This is more apparent in longer segments of record than in the short one presented in Figure 20.

c. A quasi-periodic character is visible in the data, possibly correlated with wave period.

d. The amplitude of the floating thermistor temperature fluctuations is much greater than those of the fixed. The two records appear to be almost completely in phase.

To verify the authenticity of the extremely large temperature changes observed, several wind tunnel tests of the behavior of the thermistor data collection system were conducted for various temperature, wind speed and humidity conditions.

No spray was visible during the run, and there is no evidence of the thermistor becoming wet, as it would

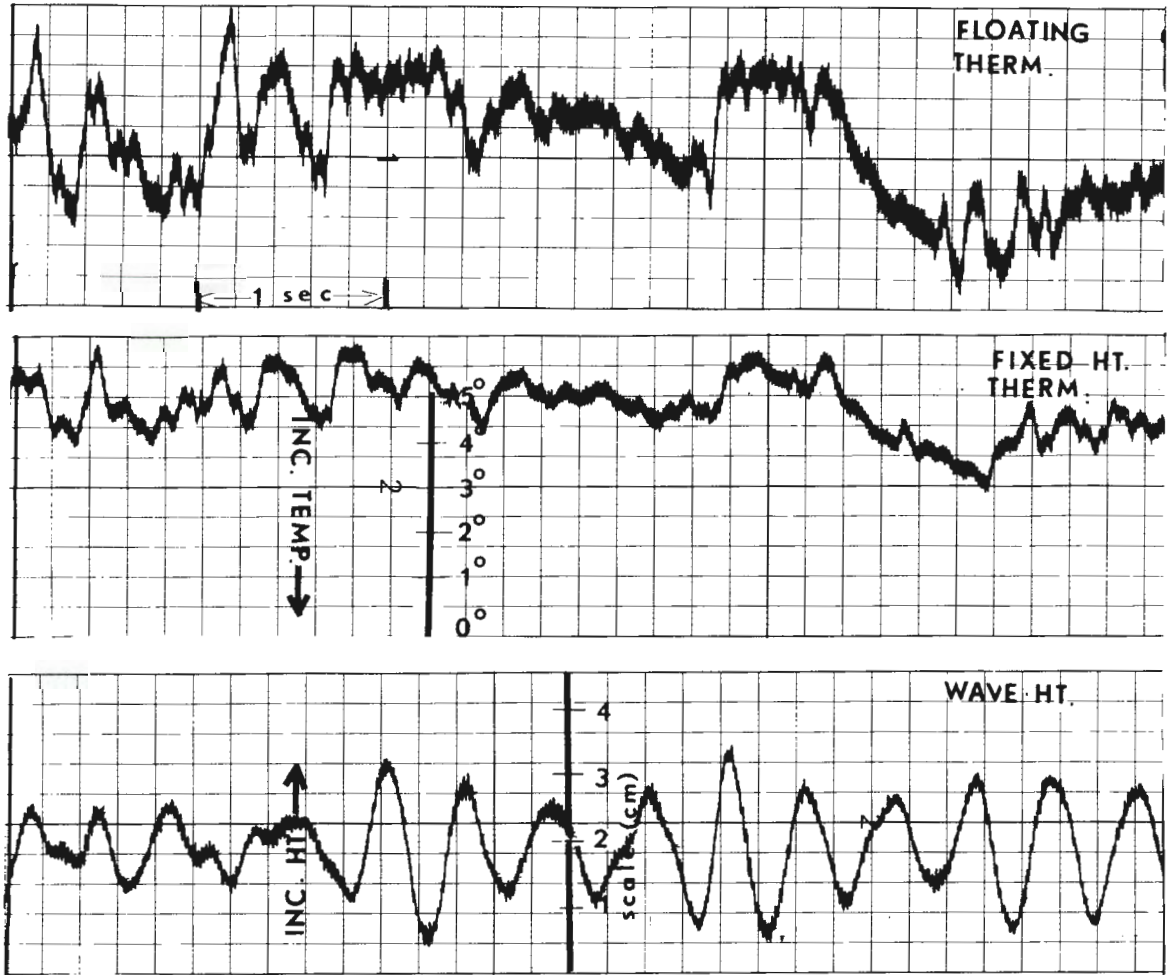

Figure 20. Record of Data from Run 2

then follow the character of the record produced under such circumstances as previously described (Figure 6).

It is noteworthy that one degree temperature fluctuations in a wind tunnel (Figure 5) are not unusual, even in a fairly uniform air stream.

It would have been desirable to check the accuracy of the thermistor during such tests by using a different sensor, but its rapid response made this impossible using the sophistication of equipment available to the authors.

A strong indication of the large temperature fluctuations was overlooked while recording both runs 2 and 3. While attempting to measure near surface air temperature in the proximity of the thermistors using a thermometer calibrated in tenths of a degree, we observed mercury level oscillations over a range of approximately 1/2 of a degree which made it necessary to take an average reading. The matter was taken lightly at the time, with little thought as to its physical significance.

There are no results of similar tests close over a water surface available for comparison. However, extremely rapid temperature fluctuations, of up to 1 degree centigrade have been recorded in the water surface film of the sea [Saunders, 1967]. Since the heat capacity of water is many times that of air, a five or six degree fluctuation in air temperature seems feasible.

Stronger confirmation of the validity of the record is obtained by the results of the statistical analysis.

Figure 21 is the power spectrum of the floating thermistor temperature record for run two. The spectra shows no significant interruption from its expected shape that can be connected with wave action. There is a suggestion of a peak at 0.2 Hz which could possibly be associated with the large negative spikes visible in the data record. However, support for this based on Figure 21 is tenuous because of the low statistical reliability of the spectrum at low frequencies. Its relation, if any, to wave motion can only be determined by the collection and analysis of much more data.

The wave spectrum for this run (Figure 22), peaks at about 2.0 Hz. The temperature spectrum (Figure 21) should be expected to similarly peak based on visual analysis of the chart records. Instead it is small, if present at all. This surprising result should be given further attention in the future.

The full 20 minutes of data collected on this run was analyzed on a Mark 7 wave analyzer. The analyzer is limited to frequencies above 2 Hz and therefore the spectra below 0.7 Hz cannot be determined when using the fastest tape speed of 60 ips (8x speed-up). The spectra above 0.7 Hz resembled very closely that of Figure 21.

The power spectrum was not corrected for signal attenuation resulting from:

Figure 21.

$\text{Log}(G_x(f))$  Float 30 Oct

1.0

10

100Hz

$-5/3$

$-5/3$

FILTER  
CORR

X - SCALE = 5.00E-01 UNITS INCH.  
Y - SCALE = 1.00E+00 UNITS INCH.

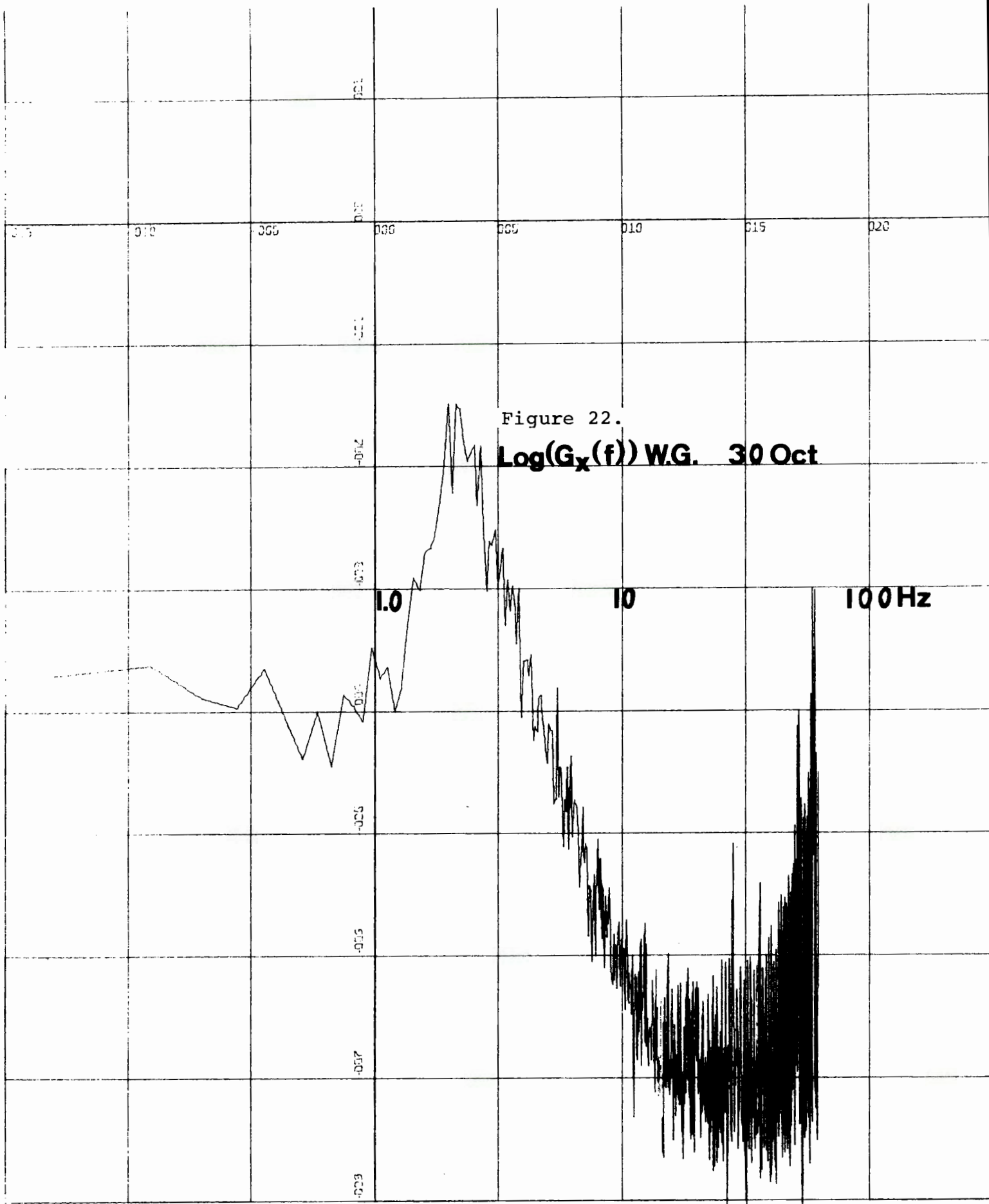

X - SCALE = 5.00E-01 UNITS INCH.  
 Y - SCALE = 1.00E+00 UNITS INCH.

a. The thermal inertia of the micro-bead thermistor, which with a time constant of 0.0505 seconds introduces 3 db attenuation of the signal at a frequency of 20 Hz.

b. The filter installed in the data collection system attenuates the signal by 1.2 db at 20 Hz (Figure 8).

c. The filter used in the digitizing process causes additional attenuation of 5.2 db at 20 Hz (Figure 18).

On Figure 21 the corrections necessary to eliminate the effect of these losses are shown at 10, 20 and 30 Hz.

The one dimensional spectrum of temperature fluctuations in the scalar inertial subrange is defined [Pond et al, 1966] by:

$$\psi(k) = A \epsilon_0 \epsilon^{-1/3} f^{-5/3} \quad (11)$$

where

$\psi(k)$  = one dimensional spectrum of temperature fluctuations

A = an absolute constant

$\epsilon_0$  = rate of dissipation of scalar variance

$\epsilon$  = rate of dissipation of turbulent energy

The slope of spectral density is less than -5/3 as frequency decreases below 1.0 Hz. This is in general agreement with the findings in the associated literature

[Pond et al, 1966]. Figure 22 is the power spectral density of wave heights.

Figures 23 and 24 are the autocorrelation functions for the floating and fixed thermistors respectively. The very close agreement in shape of the graphs confirms the similarity of the two records noted earlier.

Figure 25 is the cross correlation function between floating and fixed thermistors. The shape of the two autocorrelation functions is again duplicated. These three functions show the close phase relationship between the two thermistor records. The increase in correlation at 5 seconds lag for all 3 records is assumed to be directly related to the large negative spikes appearing in the data records.

Figure 26 is the auto correlation function for the associated wave action.

The cross correlation function between the floating thermistor and the waves is shown in Figure 27. The significant correlation for small lag times, and the increase at 6 seconds adds more evidence to the large temperature fluctuations being a result of the 5 to 7 second beat.

This data, collected at a constant height of 2.5 cm above the undulating water surface and at a fixed absolute height near the crests agrees very well with that reported by Makova whose data were collected at sea, two meters above the surface of the waves.

Figure 23. AUTO CORR FLOAT THERMISTOR 30 OCT

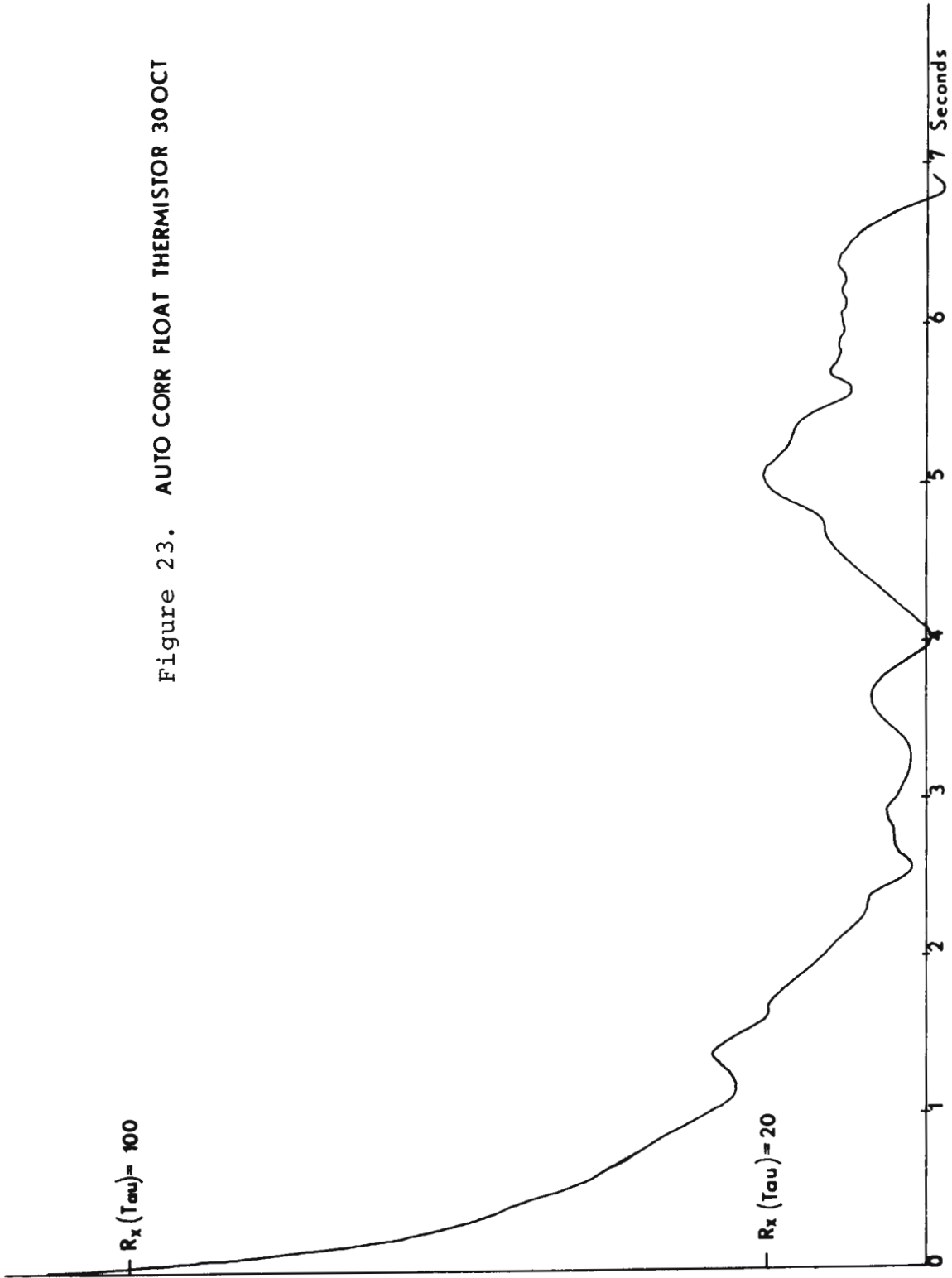

Figure 24. AUTO CORR FIXED THERMISTOR 30 OCT

53

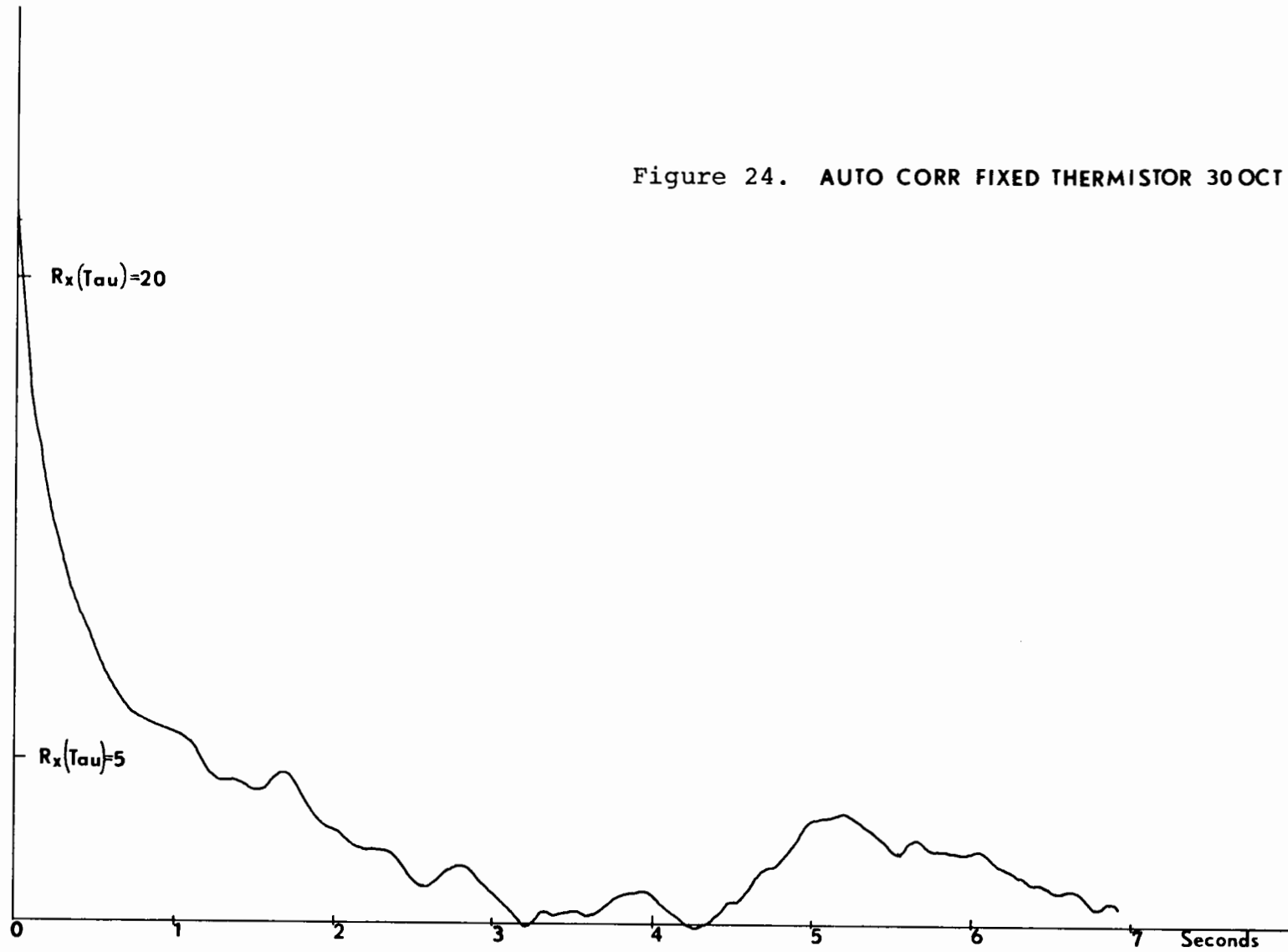

Figure 25. CROSS CORR FLOAT and FIXED 30 OCT

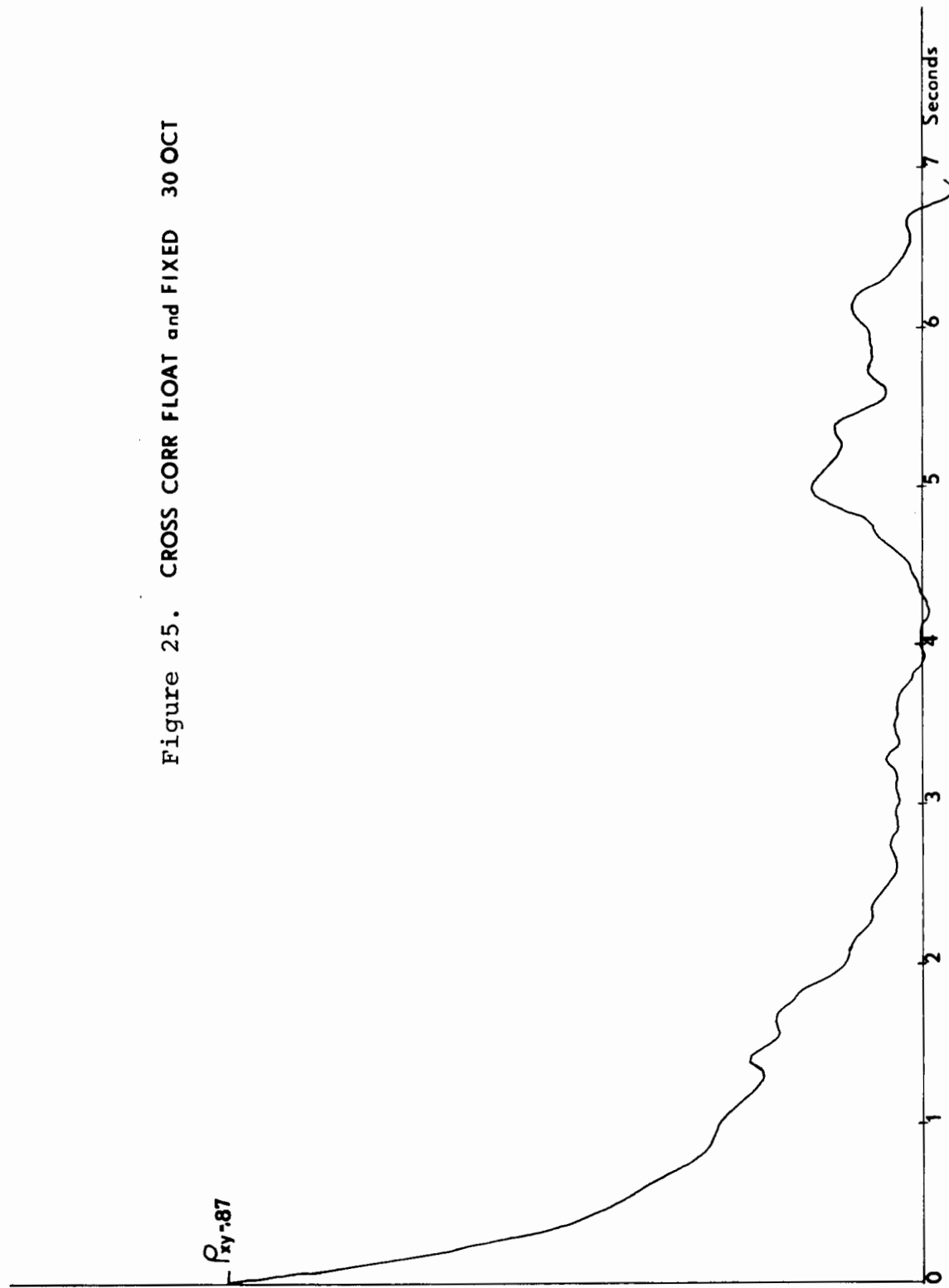

Figure 26. AUTO CORR WAVE GAGE 30 OCT

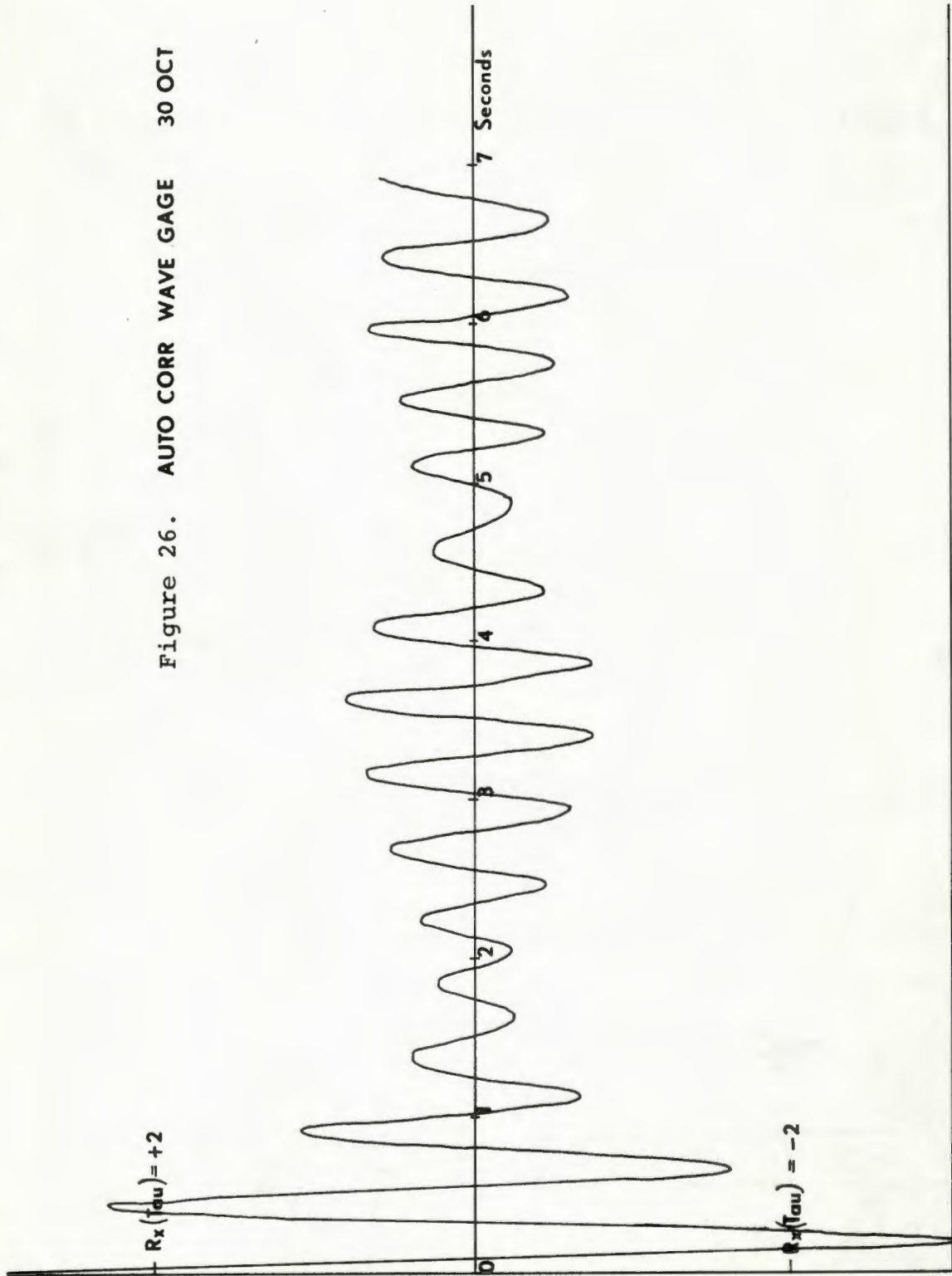
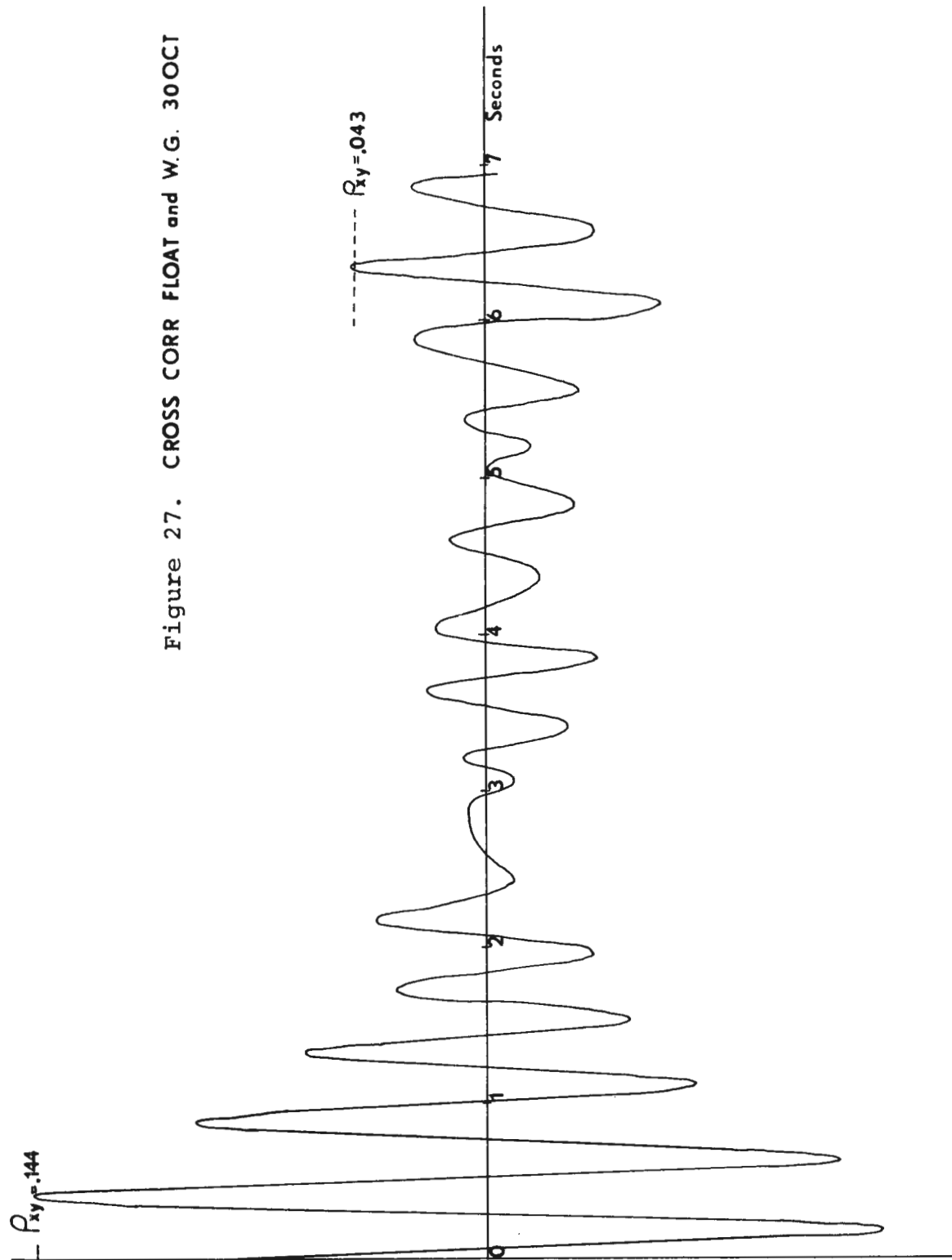

Figure 27. CROSS CORR FLOAT and W.G. 30OCT



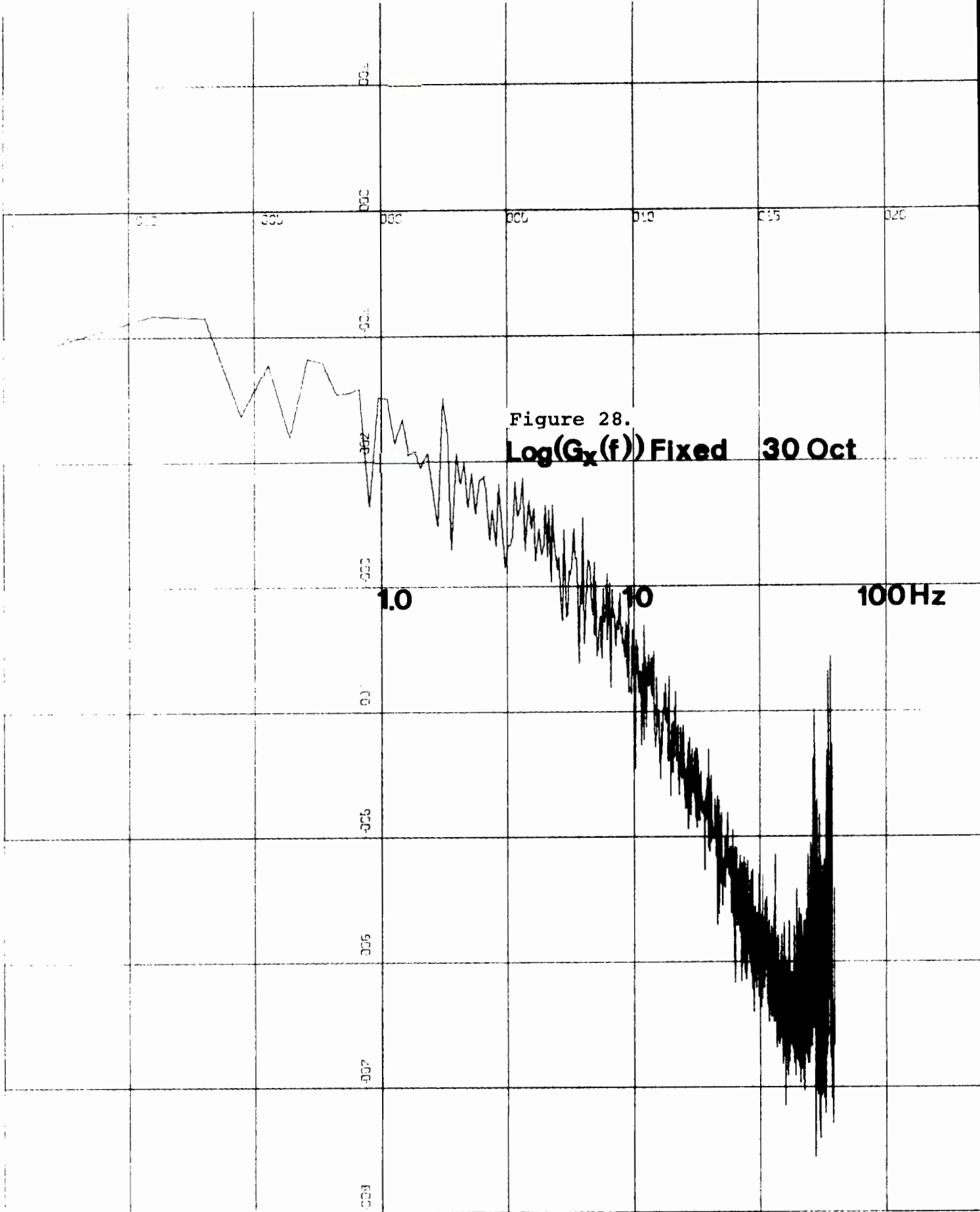

Figure 28.  
**Log( $G_x(f)$ ) Fixed 30 Oct**

X-SCALE = 5.00E-01 UNITS INCH.  
 Y-SCALE = 1.00E+00 UNITS INCH.

The temperature sensing circuit (Figure 7) was the end product of the several modifications necessary to solve the numerous equipment problems arising in the field. The schematic diagram does not show the actual unorthodox wiring which resulted, and was the probable cause of the undesirable high noise level recorded with the useful information (Figure 20). Sophistication in construction of even this basic circuit would eliminate much of the noise and reduce the severe filtering, with its accompanying signal distortion, that was necessary. Some filtering will always be necessary in the "A" to "D" process to prevent aliasing error.

### 3. Run Number Three

The mean wind during this run was 6.6 meters per second. Relative humidity was 71%. Atmospheric pressure was 1021.5 mb. Water temperature at a depth of 6 cm was 15.6°C and at 15 cm it was 15.7°C. Mean air temperature recorded by the floating thermistor was 12.0°C. This thermistor was adjusted on the float to ride 3.5 cm above the water surface (1 cm higher than on run 2).

To obtain some indication of the mean temperature profile, and to gain some insight to the significance of the amplitude of the temperature fluctuations, the fixed thermistor was repositioned for the second half of this run.

Initially, it was 7 cm above MWL (4.5 cm above a wave with the observed significant height ( $H_{1/3}$  of 5 cm)

and registered a mean temperature of 10.7°C. After relocation, it was 15.5 cm above MWL and registered a mean temperature of 10.3°C.

The above temperatures determined by the thermistor calibration curves were confirmed by mercury thermometer measurements.

Figure 29 is an excerpt from the record of data collected on this run. Rapid fluctuations of greater than 3 degrees are fairly common, but the 5 degree spikes noted on the previous run are missing. The amplitude of the fluctuations sensed by the floating thermistor are again much greater than those of the fixed. This difference, however, is not as great as on run two.

There again is evidence of a periodic component, attributed to the associated wave activity. A negative temperature transient frequently coincides with a peak in wave height. This trend continues, even after the relocation of the fixed thermistor.

Figure 30 is an attempt to summarize the vertical profile of mean temperature and to explain the range of temperature fluctuations recorded at various heights.

A hypothetical model of the unperturbed average isotherms over the surface of a wave is shown in Figure 31. Selecting a coordinate system moving to the left with wave celerity and assuming the isotherms moving to conform with the water surface, the thermistors would then appear to move to the left, pass through the extremes shown,

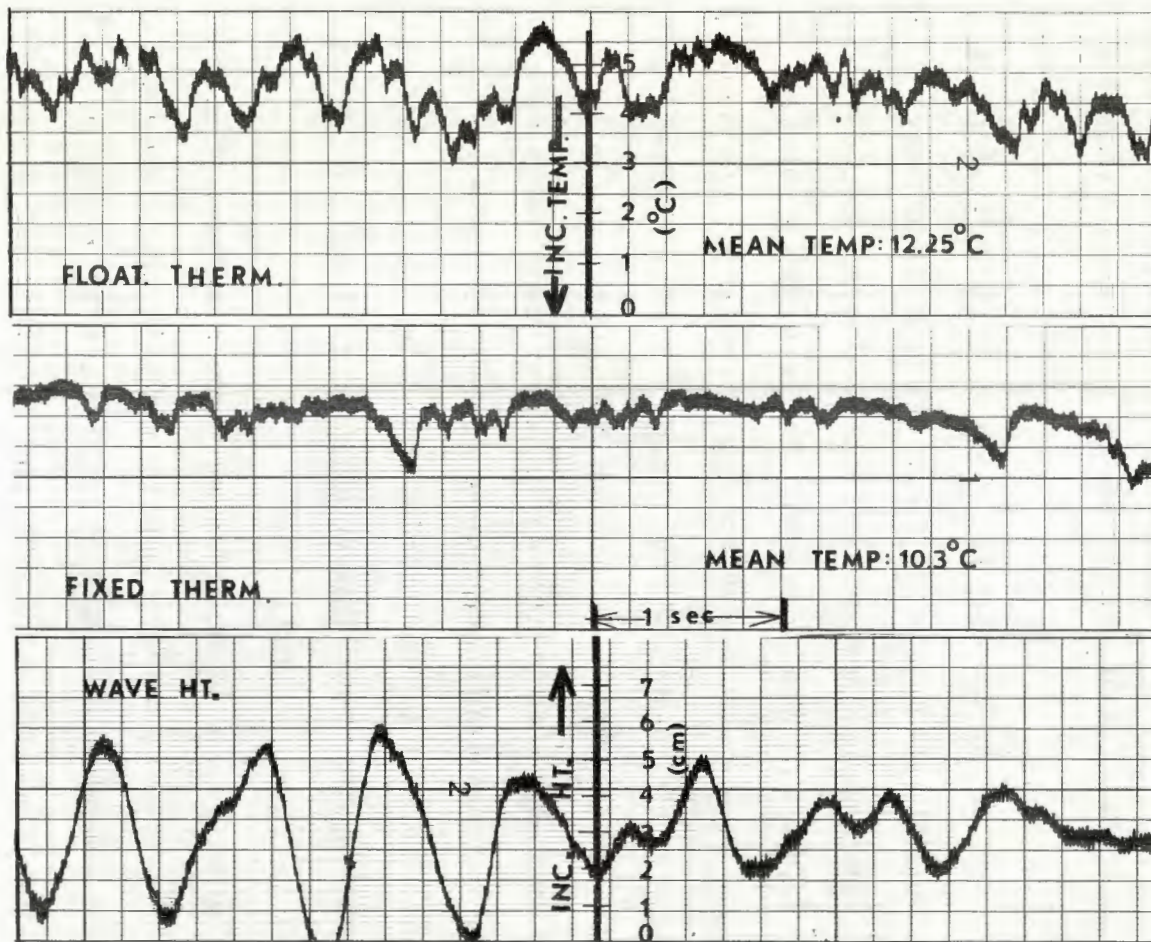

Figure 29. Record of Data From Run 3

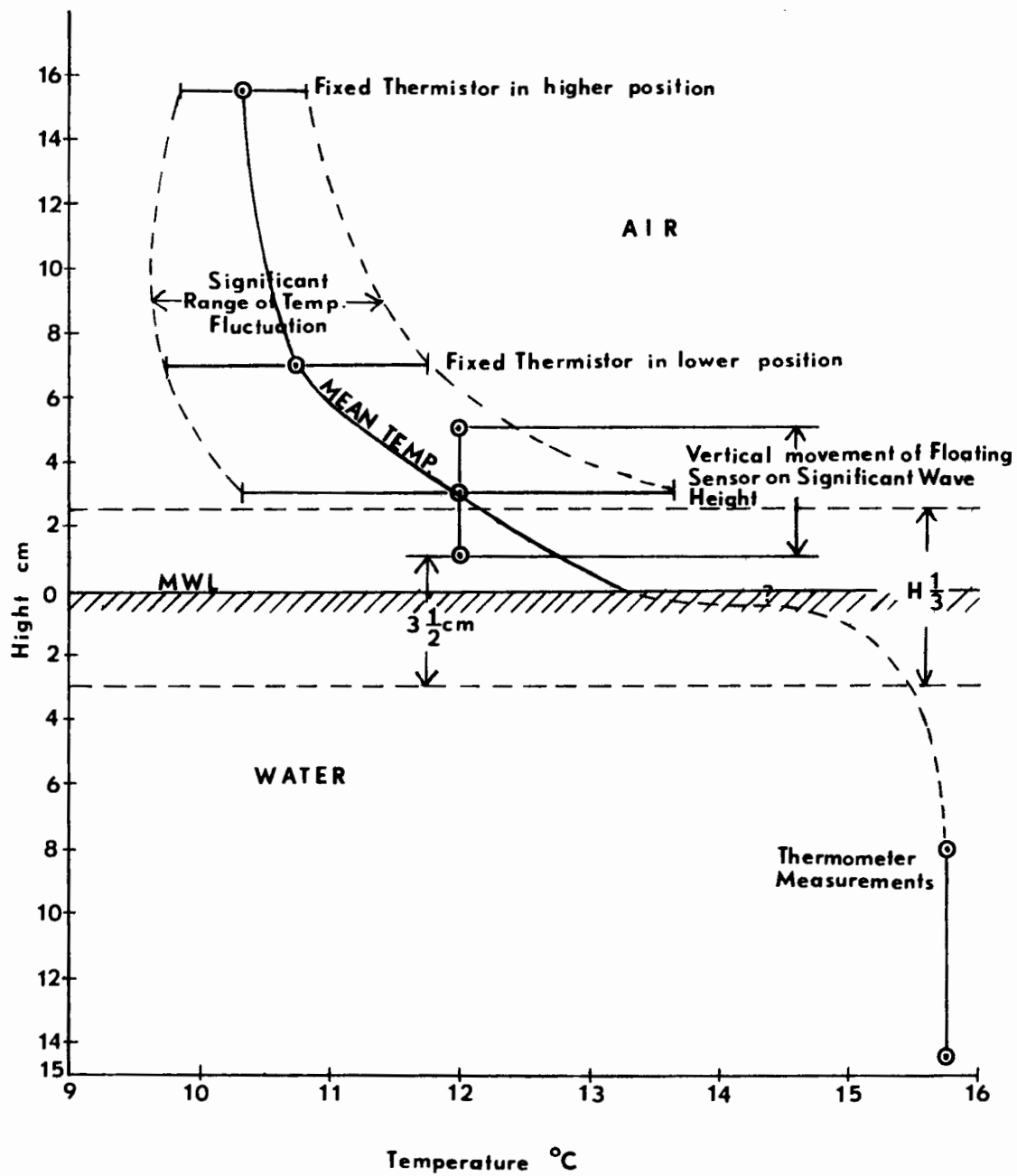

Figure 30. Vertical Profile of Mean Temperature

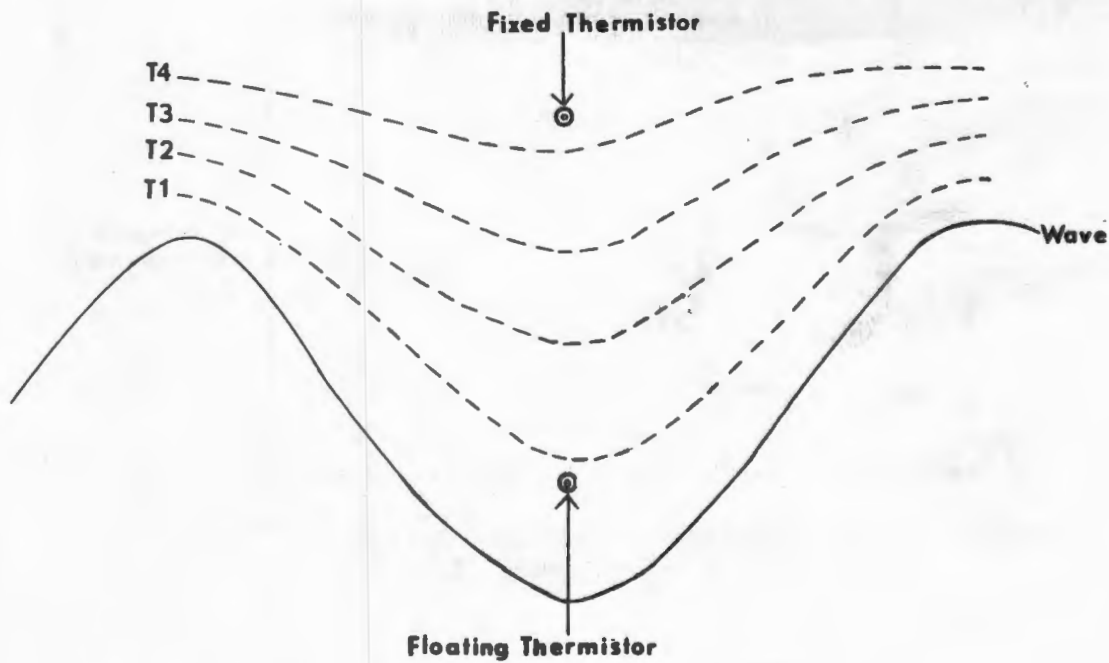
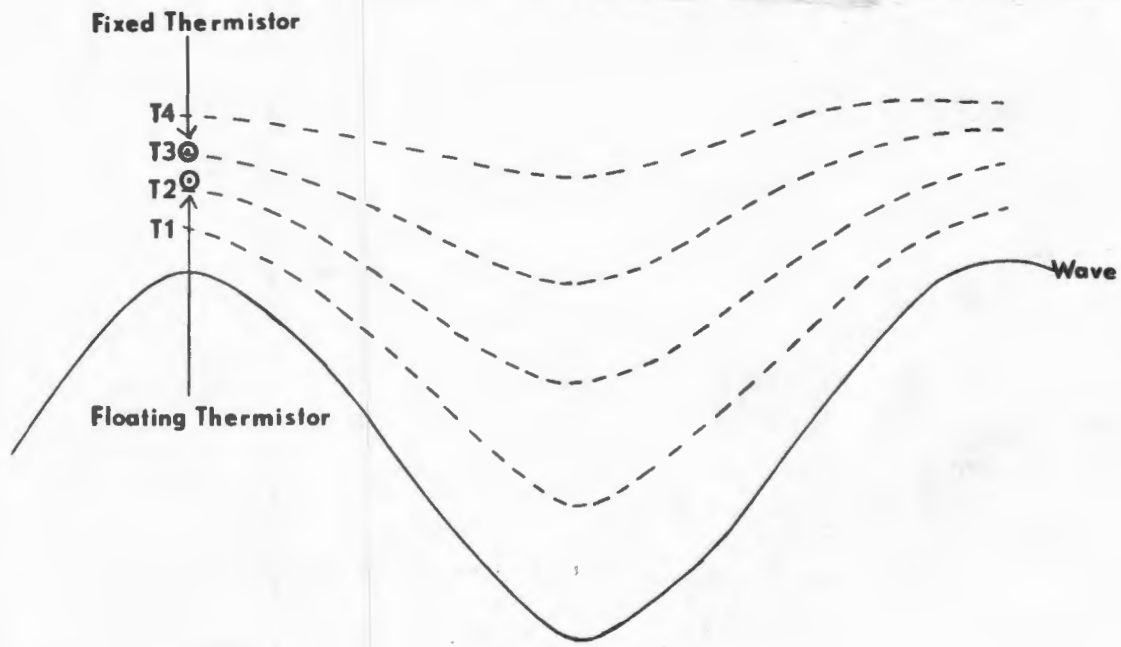

Figure 31. Isotherm Model

and produce the periodic component of the temperature spectrum.

The shape of the isotherms resembles the unperturbed mean wind velocity streamlines in the Miles hypothesis for the generation of wind waves [Stewart, 1967].

The strongest justification for the 5 degree fluctuation of run 2 is supplied by comparison with run 3. The existence of the 2 to 3 degree fluctuations of run 3 are considered reasonable (or possible, if you prefer). If accepted, and if the signal recorded during run 2 is truly temperature, then the possibility of 5 degree fluctuations follows directly from the fact that the general intensity of this data, essentially described by the mean square value, is almost 5 times greater for run 2.

Specifically, the mean square values (on a relative scale of the voltage recorded during conversion from analog to digital) are:

- a. For 30 October
  - (1) Float 112 volts<sup>2</sup>
  - (2) Fixed 22 volts<sup>2</sup>
- b. For 12 November (First half)
  - (1) Float 22 volts<sup>2</sup>
  - (2) Fixed 20 volts<sup>2</sup>
- c. For 12 November (Second half)
  - (1) Float 27 volts<sup>2</sup>
  - (2) Fixed 14.8 volts<sup>2</sup>

The absence of the 5° fluctuations on 12 November can be explained by one or both of the following reasons.

a. The floating thermistor was located 1 cm nearer the water surface during run two.

b. A sharper temperature gradient existed during the earlier run.

The power and correlation functions for this run reveal nothing to amplify or discredit the highlights discussed for run 2. They are included as Figures 32 to 47.

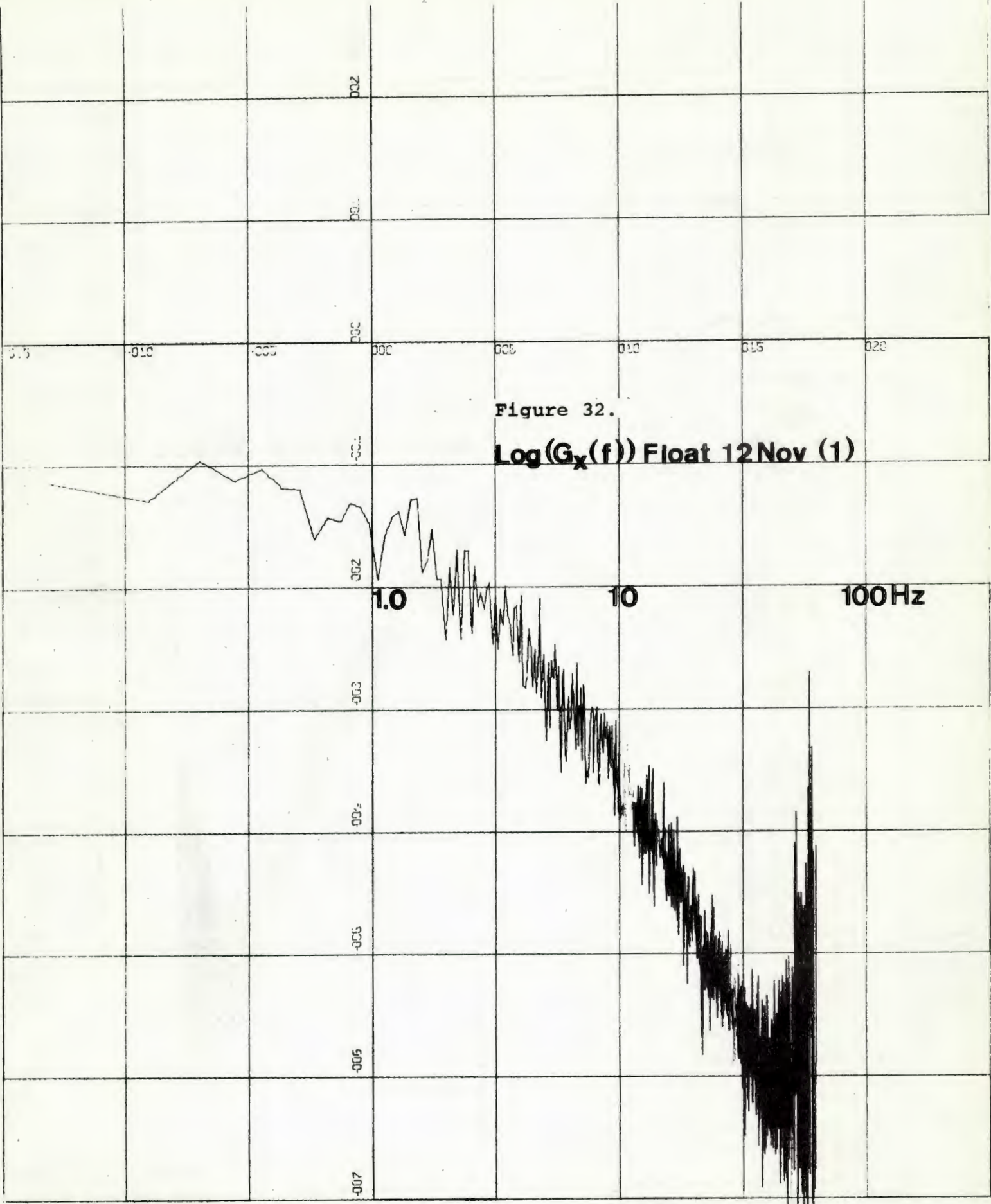

Figure 32.

$\text{Log}(G_x(f))$  Float 12 Nov (1)

X-SCALE = 5.00E-01 UNITS INCH.  
 Y-SCALE = 1.00E+00 UNITS INCH.

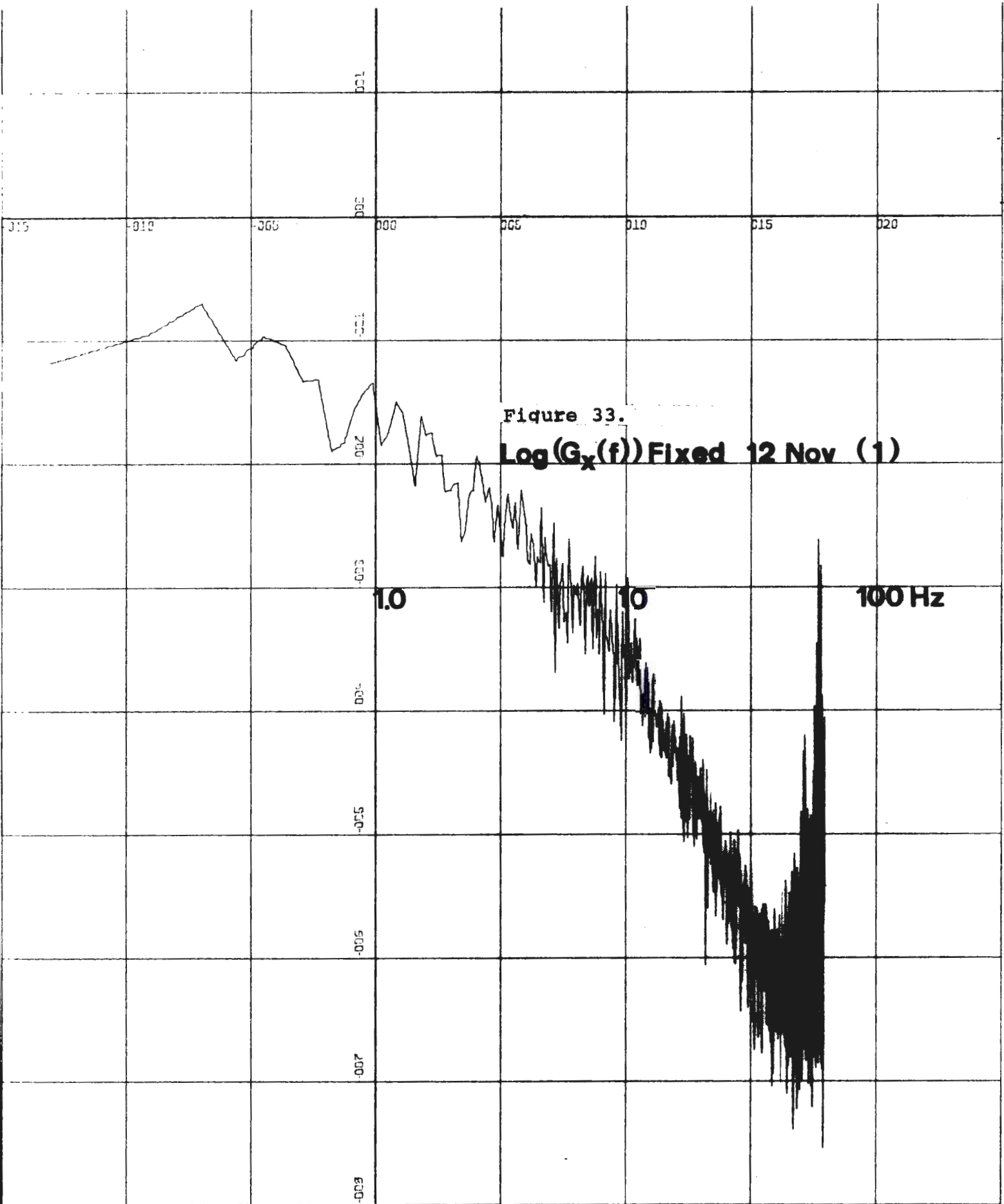

Figure 33.  
**Log( $G_x(f)$ ) Fixed 12 Nov (1)**

X-SCALE = 5.00E-01 UNITS INCH.  
 Y-SCALE = 1.00E+00 UNITS INCH.

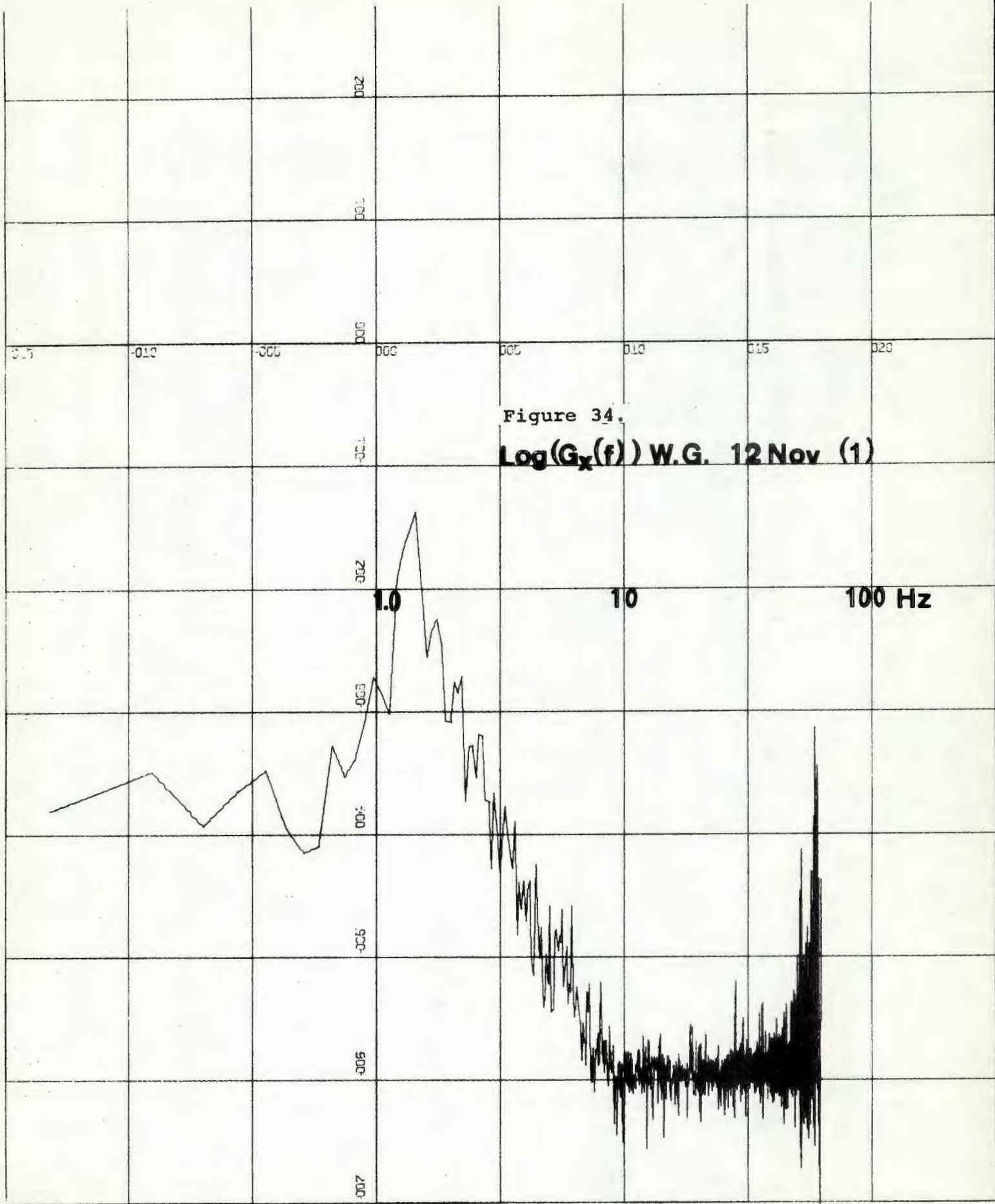

Figure 34.  
 $\text{Log}(G_x(f))$  W.G. 12 Nov (1)

X-SCALE = 5.00E-01 UNITS INCH.  
 Y-SCALE = 1.00E+00 UNITS INCH.

Figure 35. AUTO CORR FLOAT THERMISTOR 12 NOV (1)

89

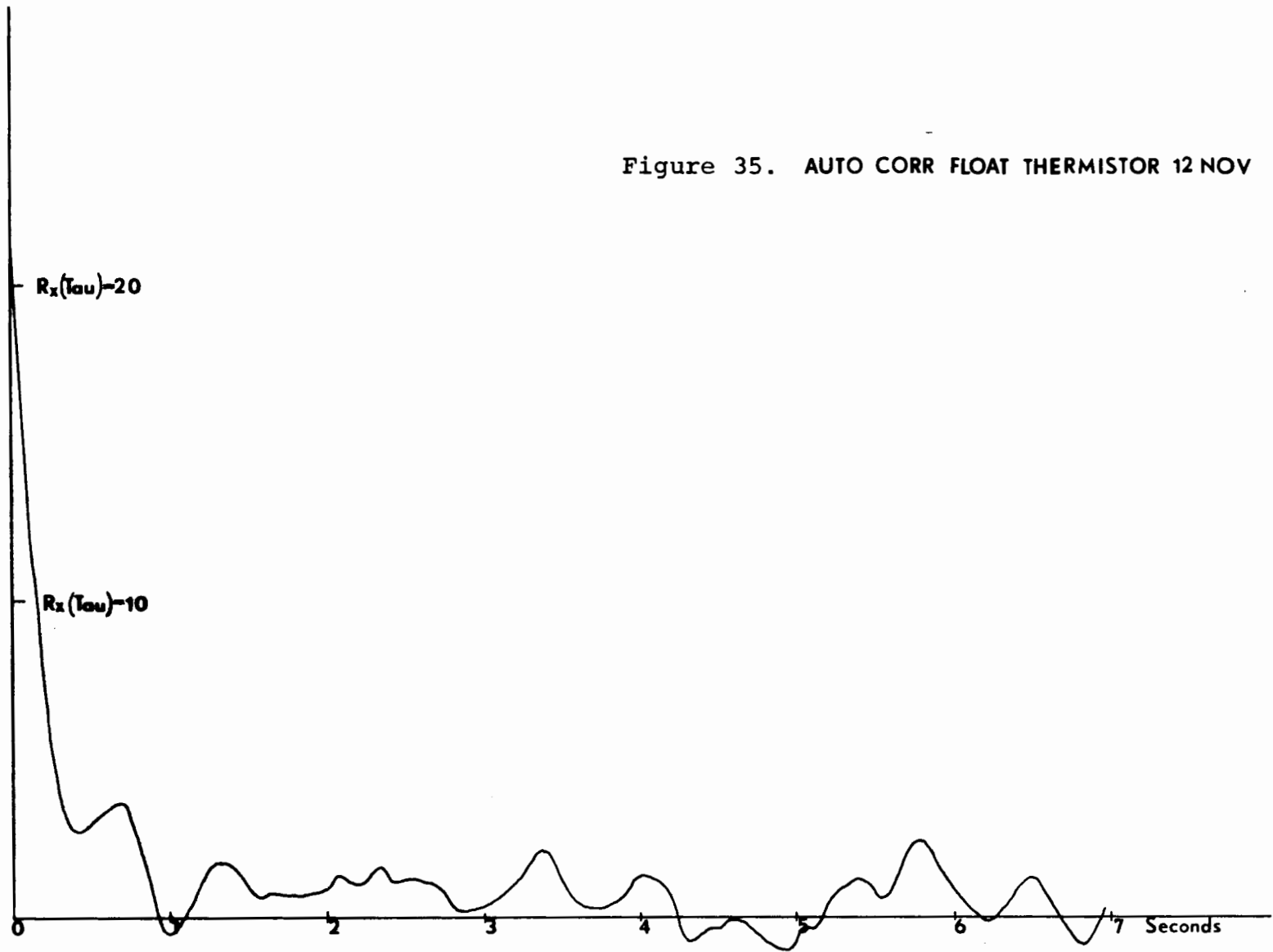

Figure 36. AUTO CORR FIXED THERMISTOR 12 NOV (1)

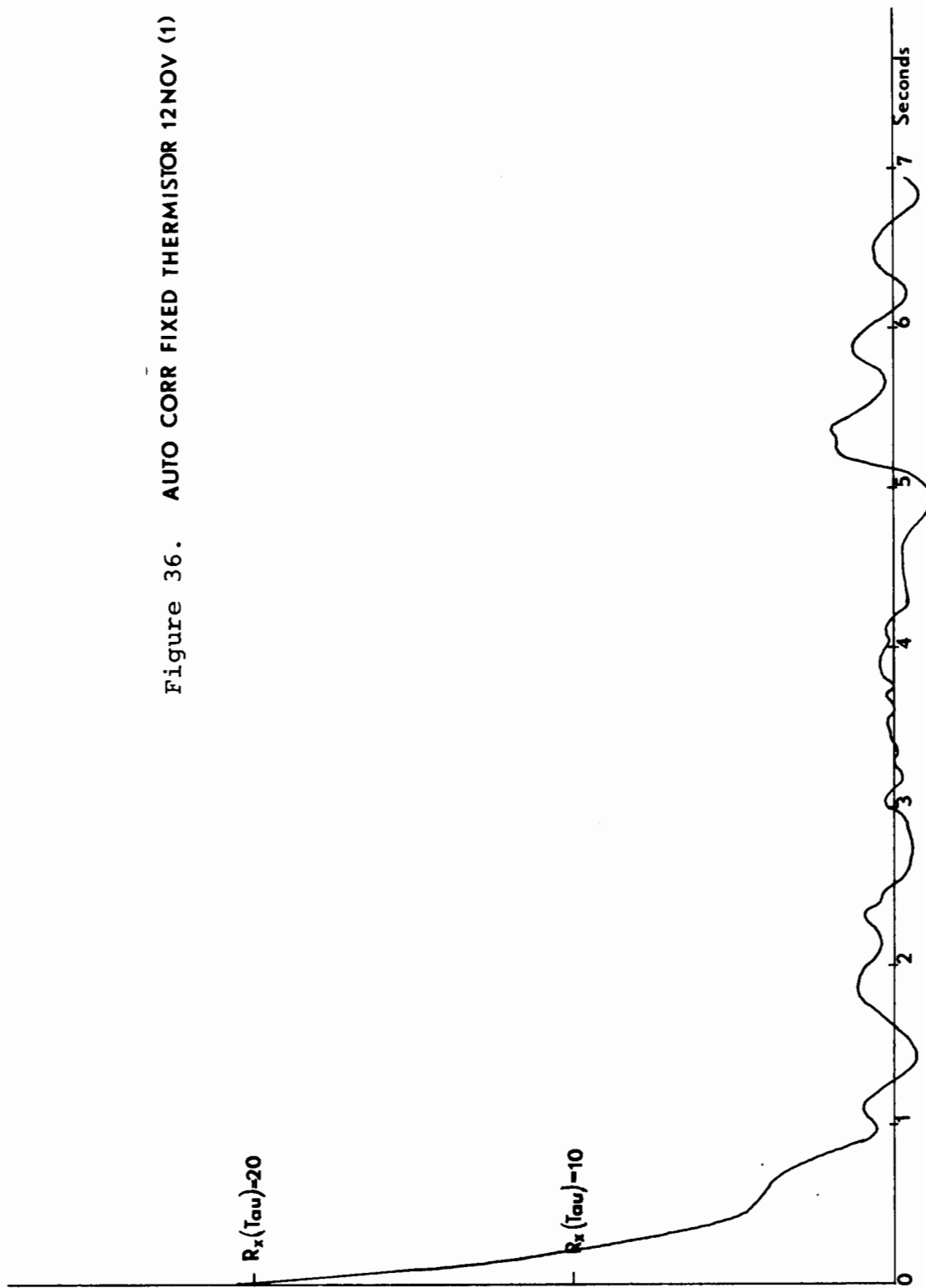

Figure 37. AUTO CORR WAVE GAGE 12 NOV (1)

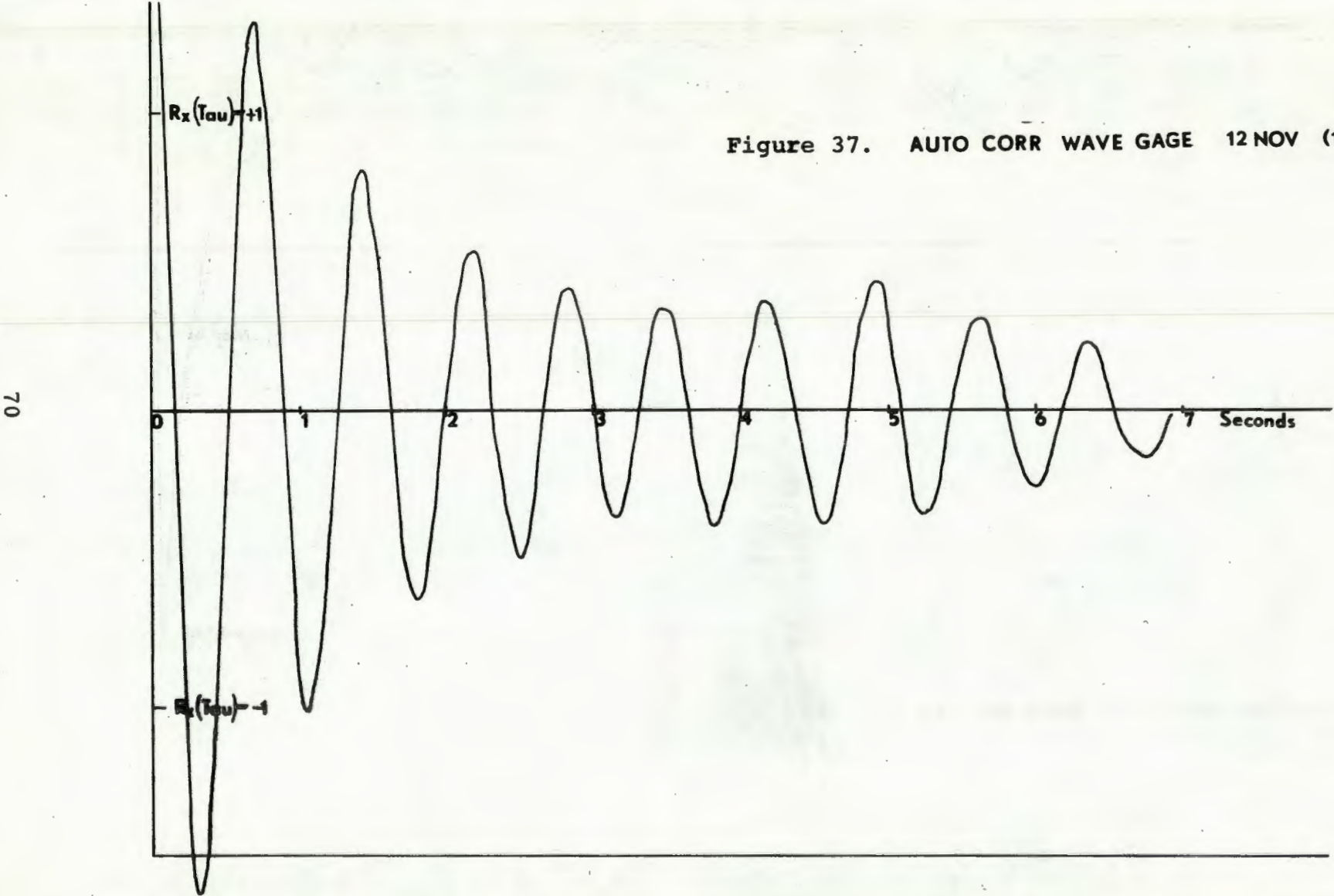

Figure 38. CROSS CORR FLOAT and W.G. 12 NOV (1)

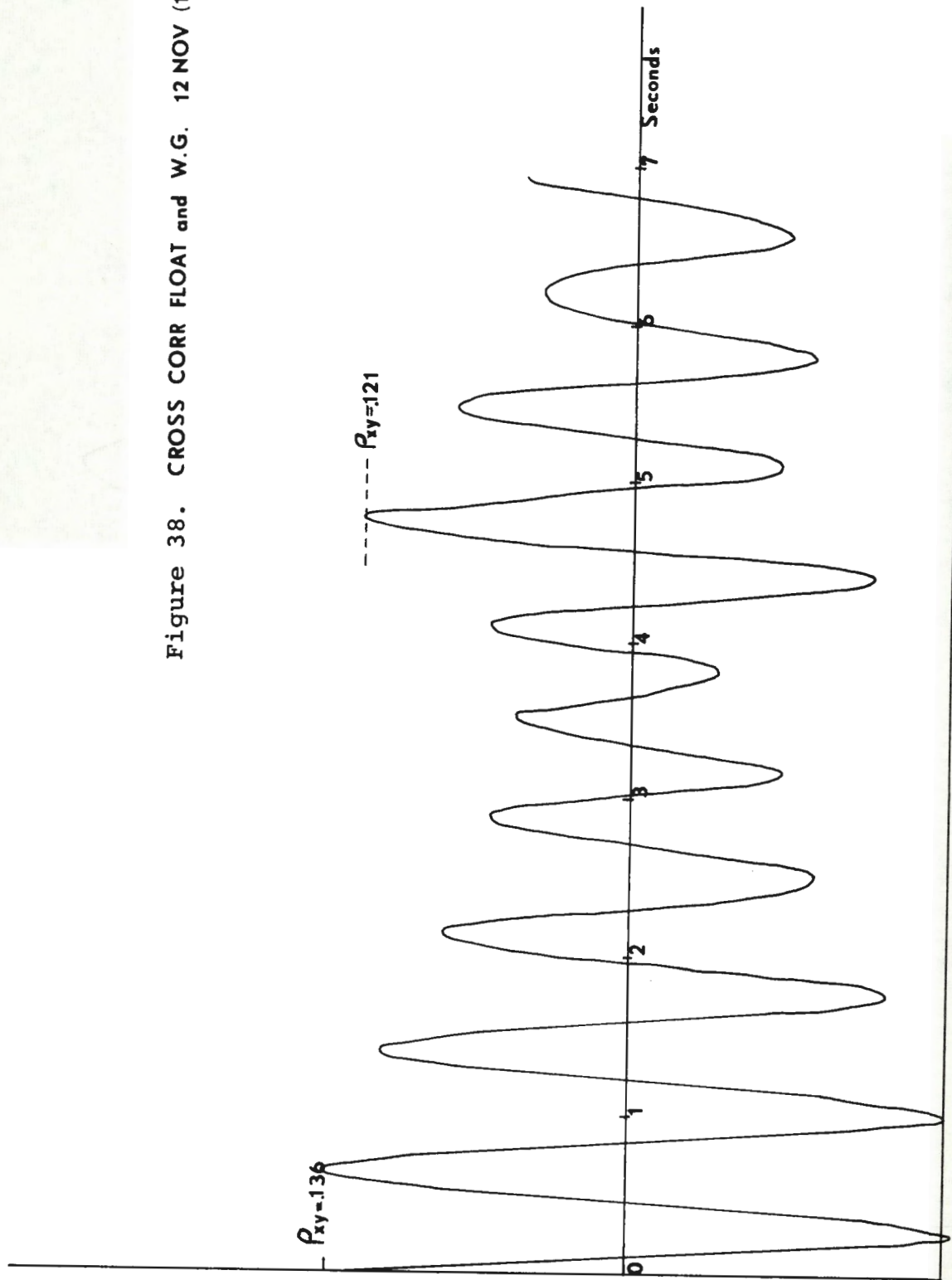
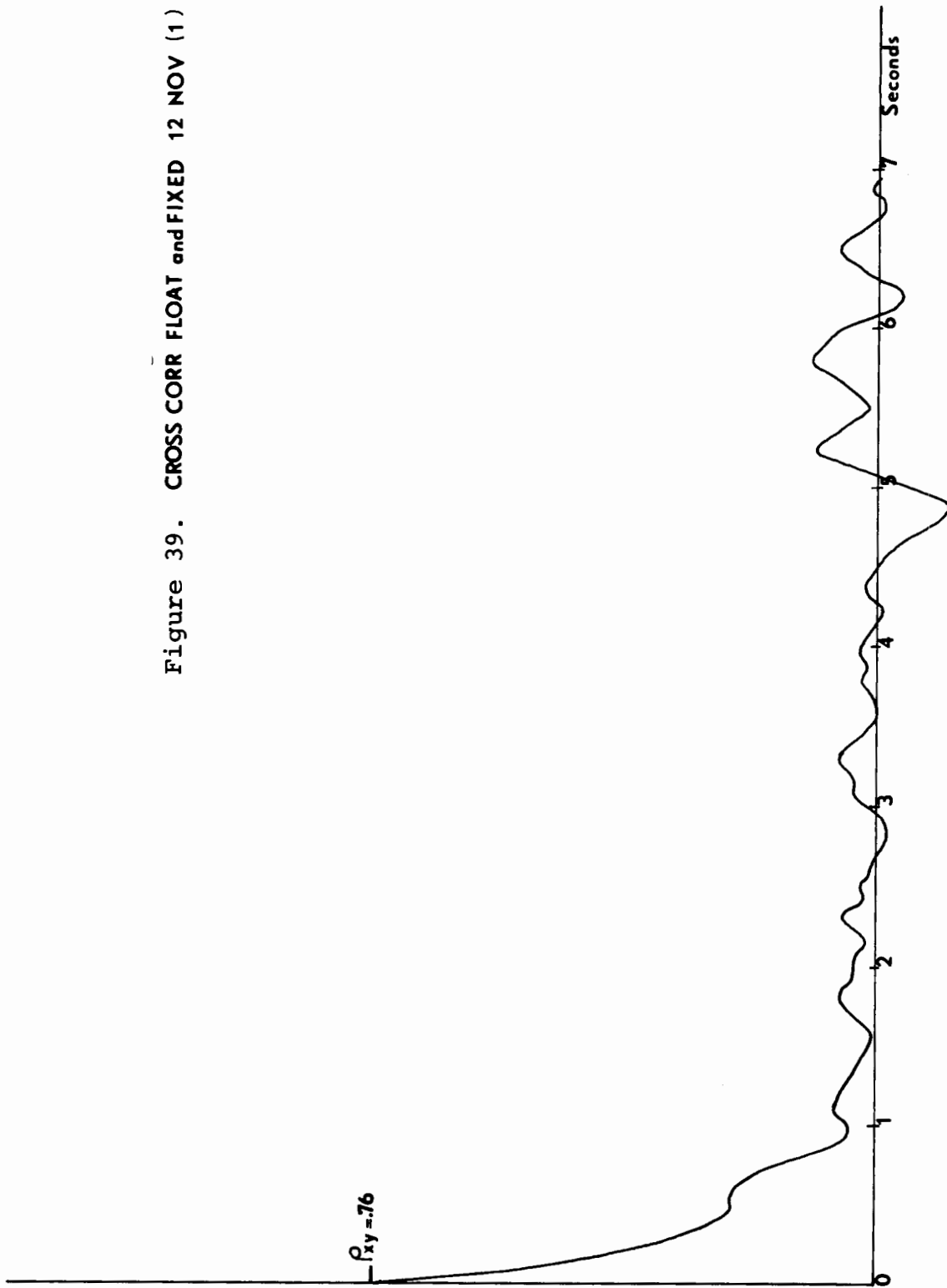

Figure 39. CROSS CORR FLOAT and FIXED 12 NOV (1)



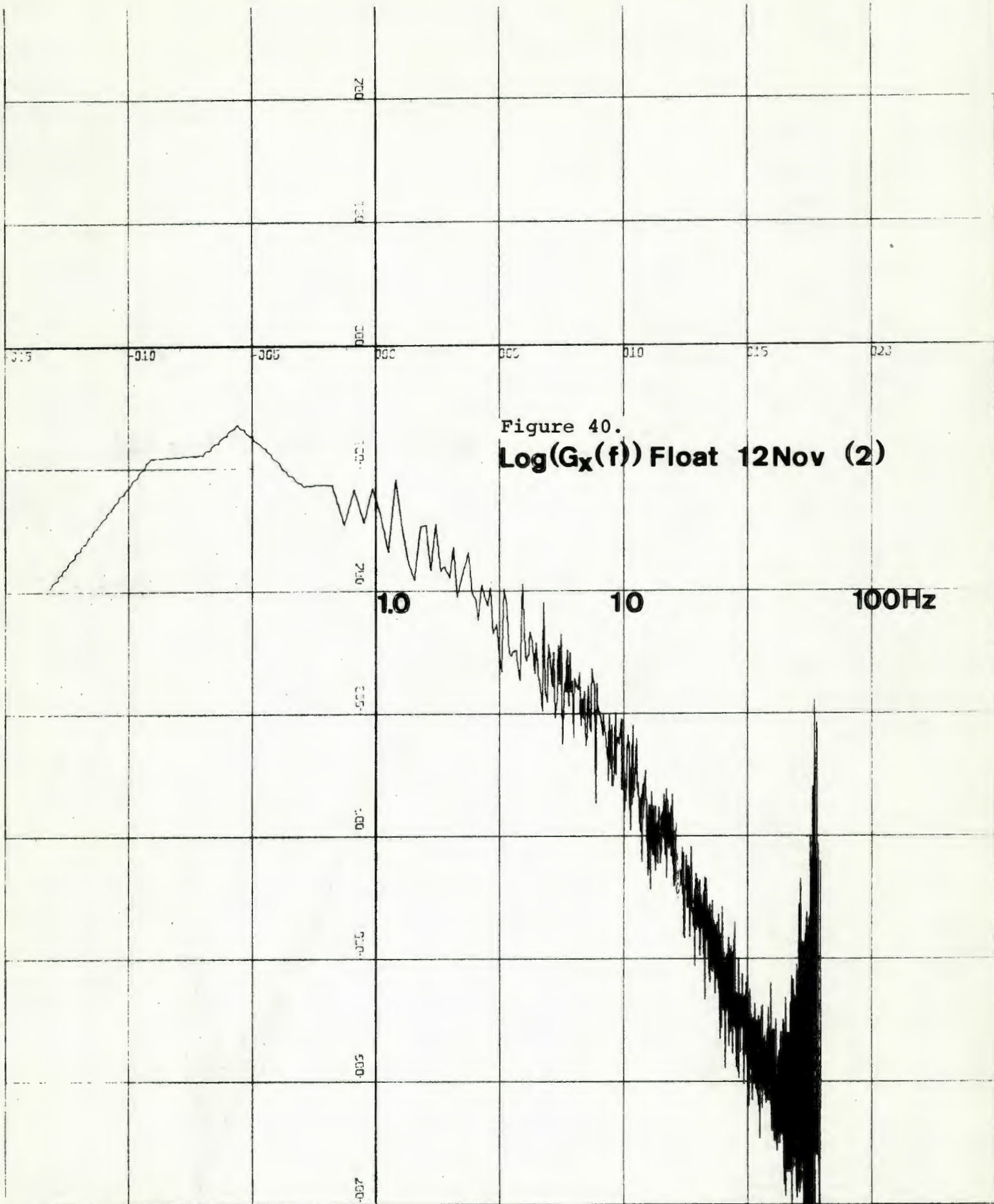
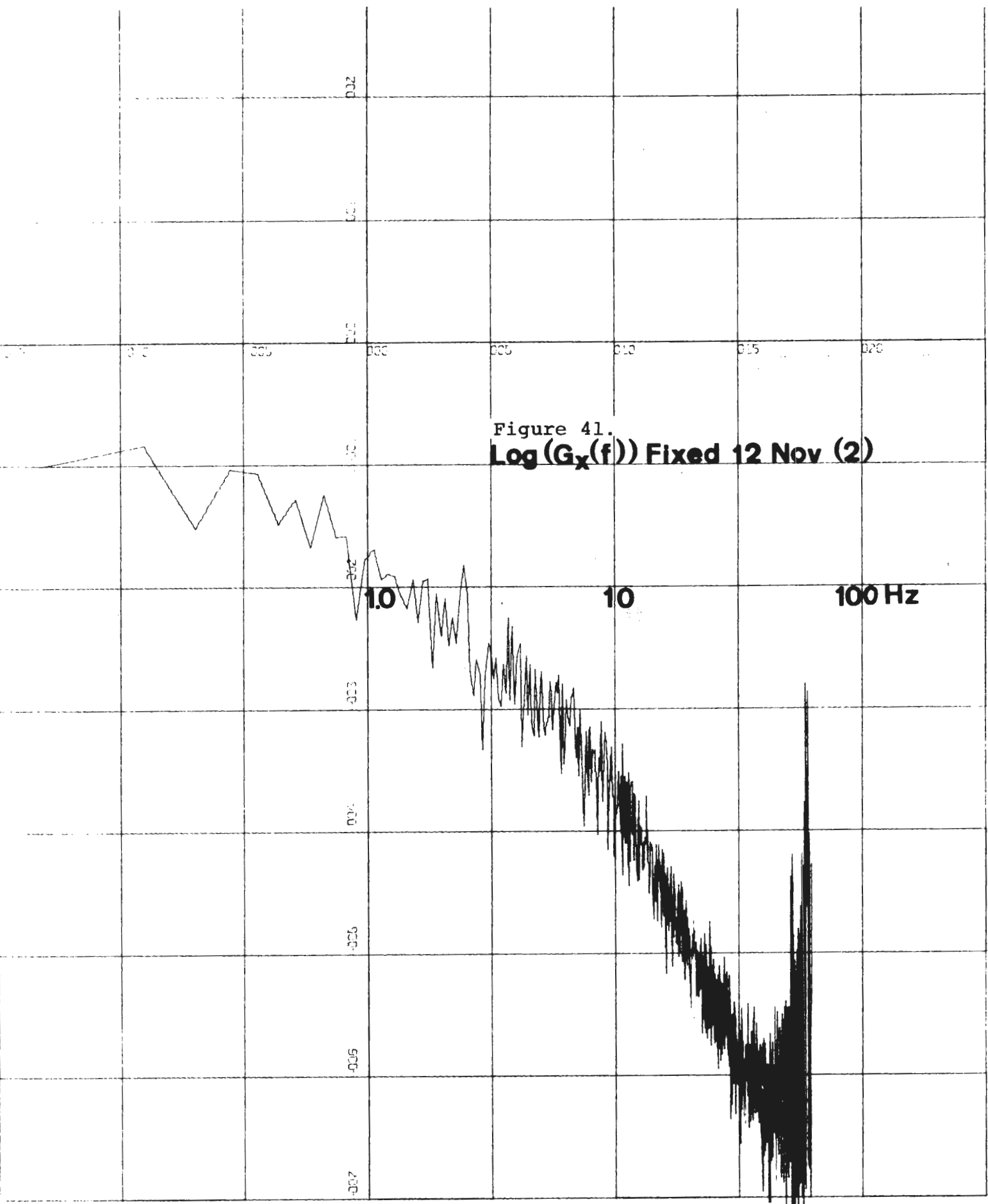

Figure 40.  
**Log(G<sub>x</sub>(f)) Float 12Nov (2)**

X-SCALE = 5.00E-01 UNITS INCH.  
 Y-SCALE = 1.00E+00 UNITS INCH.

Figure 41.  
**Log (G<sub>x</sub>(f)) Fixed 12 Nov (2)**



X-SCALE = 5.00E-01 UNITS INCH.  
Y-SCALE = 1.00E+00 UNITS INCH.

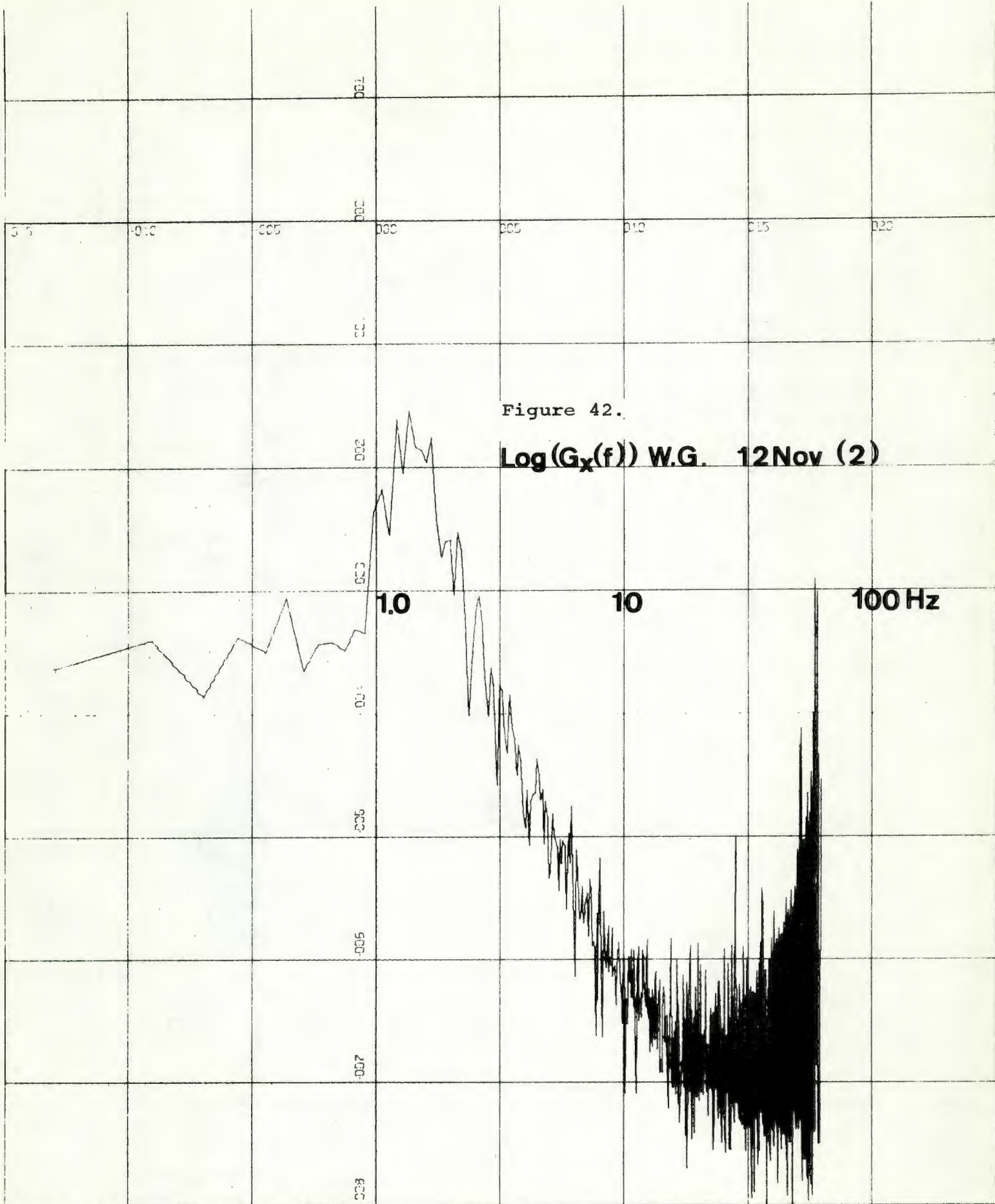

Figure 42.

**Log( $G_x(f)$ ) W.G. 12Nov (2)**

**1.0**

**10**

**100 Hz**

X-SCALE = 5.00E-01 UNITS INCH.  
 Y-SCALE = 1.00E+00 UNITS INCH.

Figure 43. AUTO CORR FLOAT THERMISTOR 12 NOV (2)

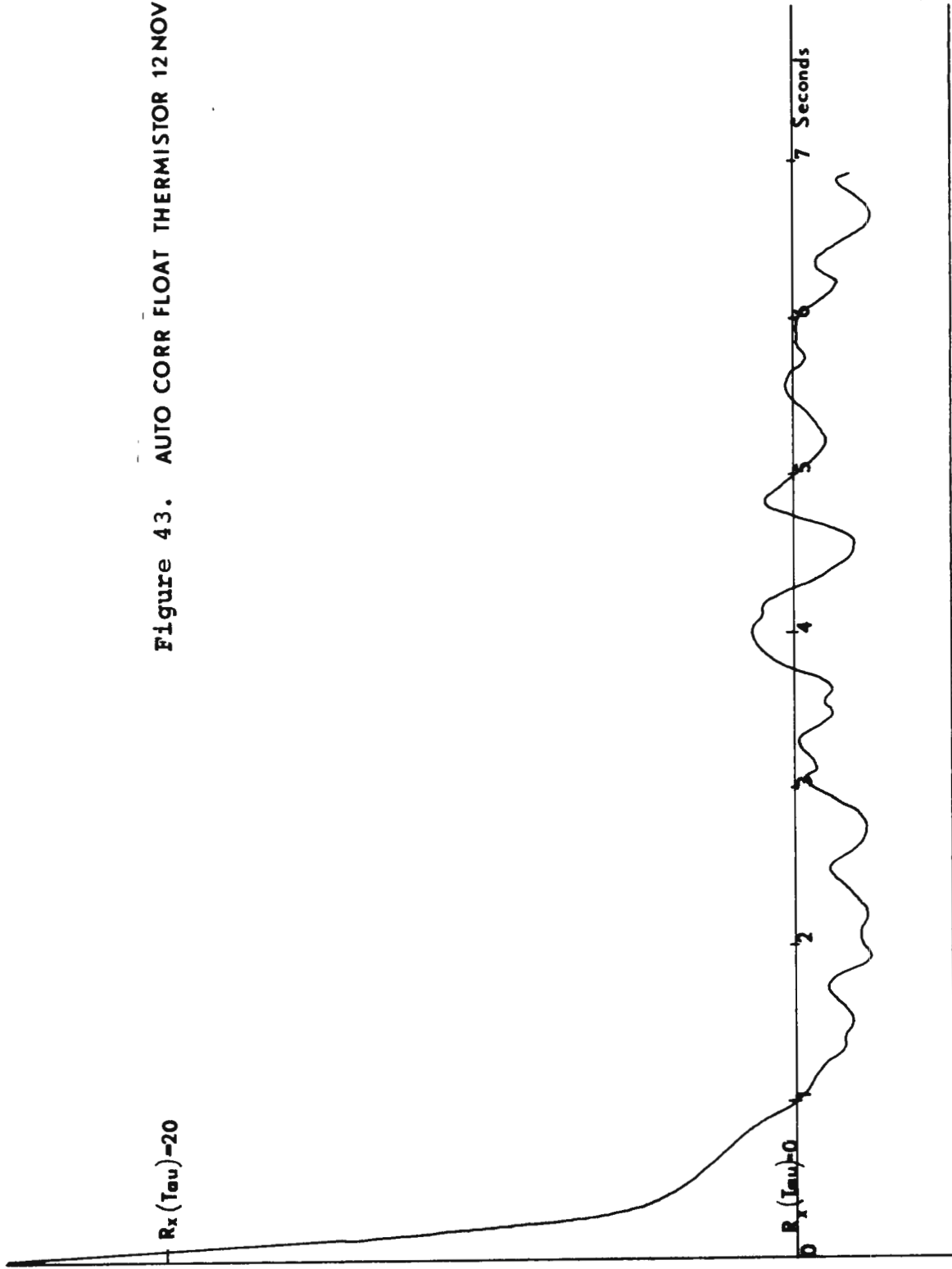

Figure 44. AUTO CORR FIXED THERMISTOR 12 NOV (2)

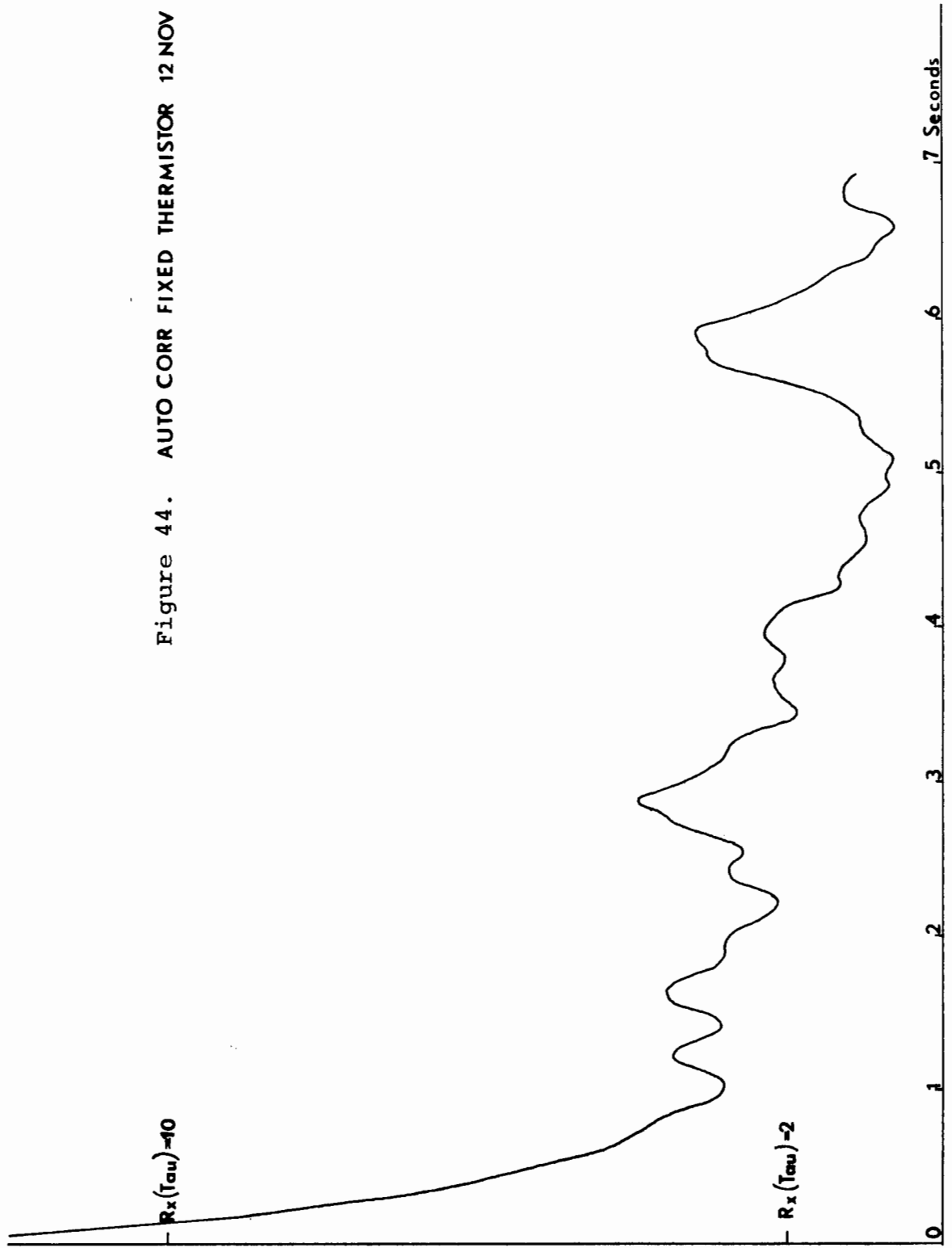

Figure 45. AUTO CORR WAVE GAGE 12 NOV (2)

78

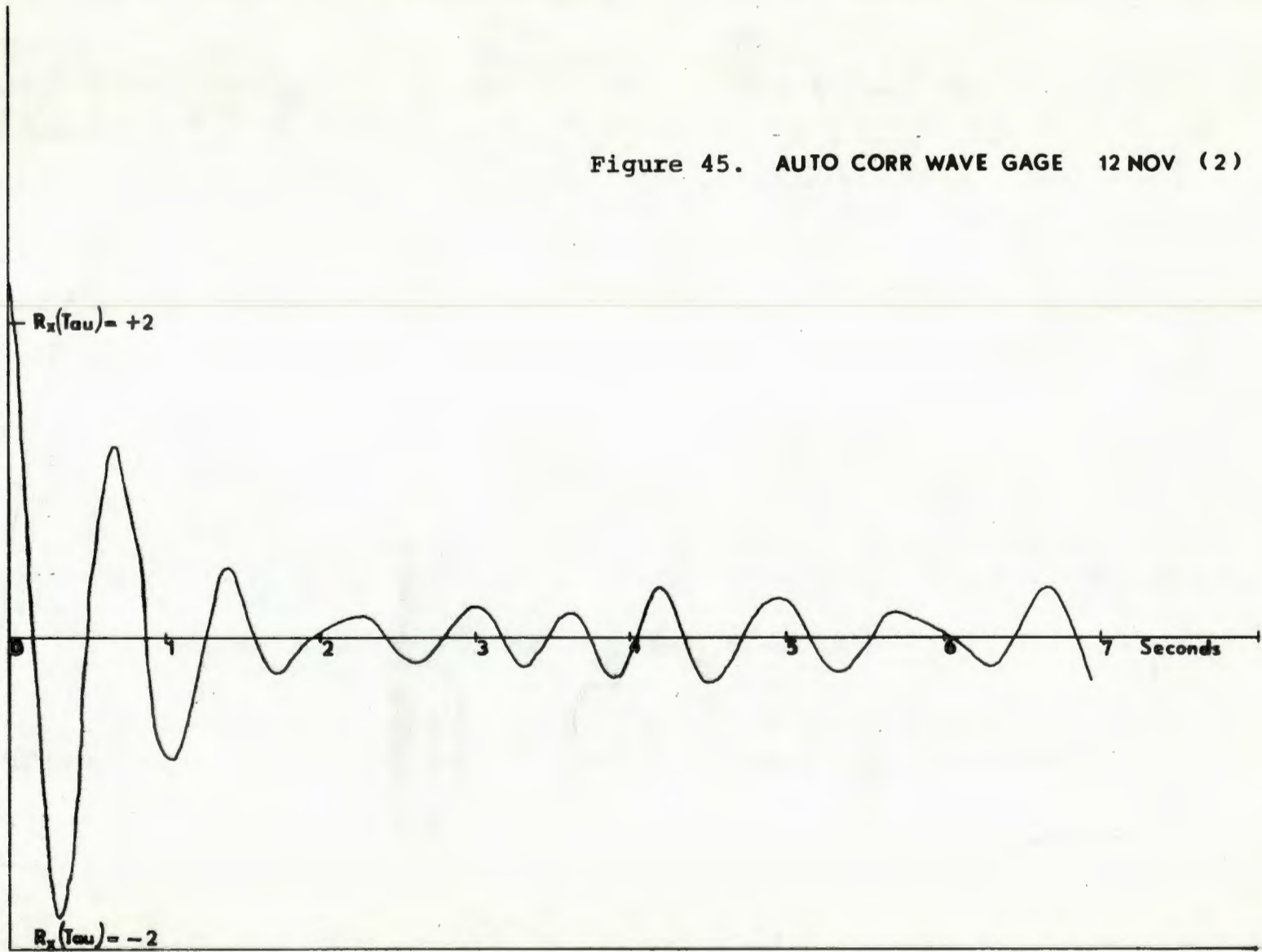
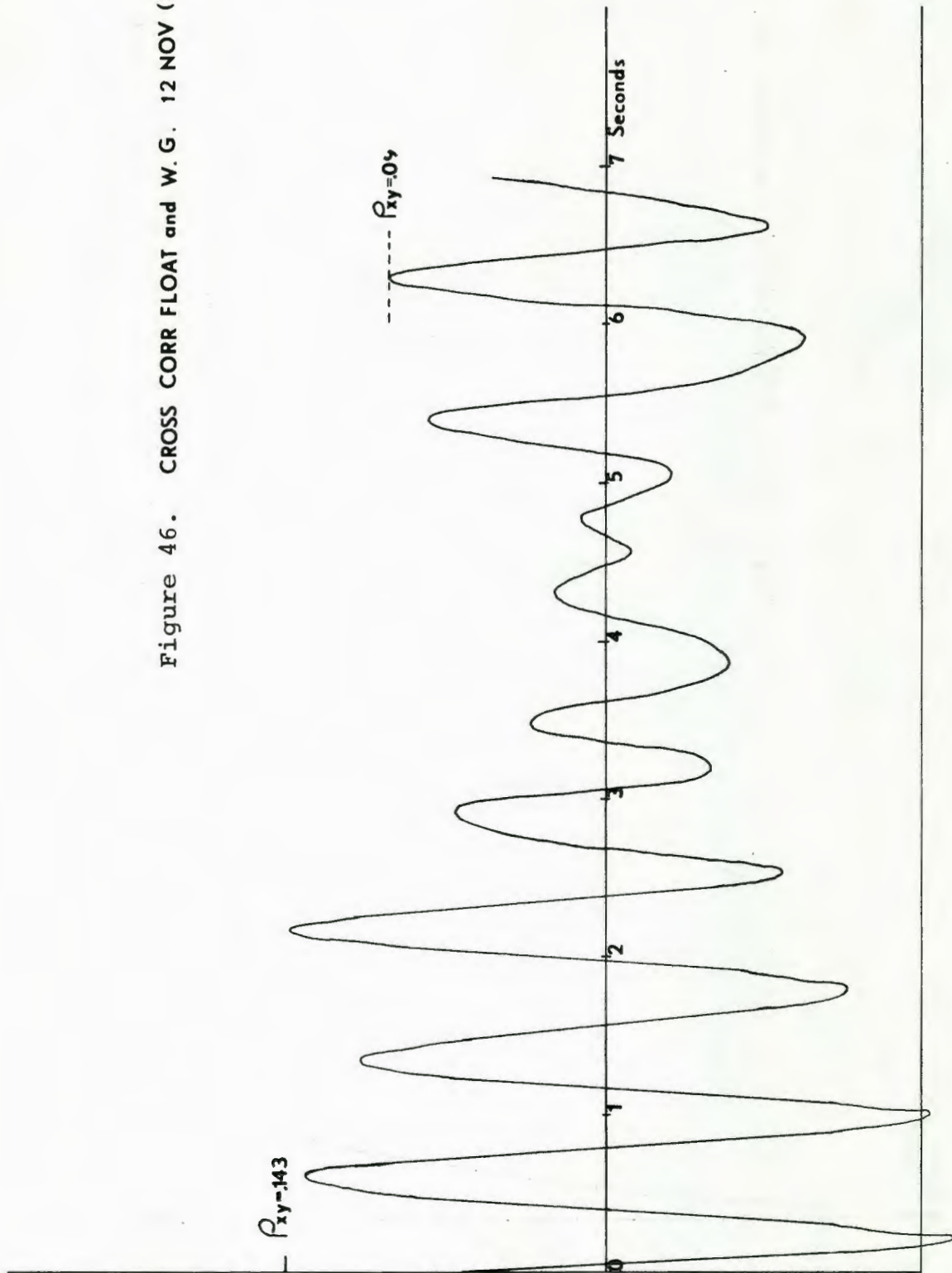
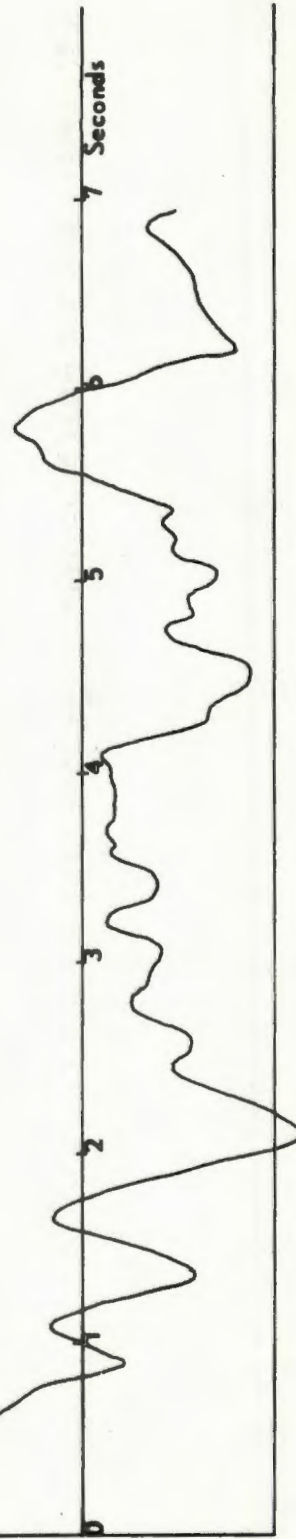

Figure 46. CROSS CORR FLOAT and W. G. 12 NOV (2)



Pxy-54

Figure 47. CROSS CORR FLOAT and FIXED 12 NOV (2)



## V. CONCLUSIONS

This system for collecting temperature and wave height data near the surface of the waves has been proven to be successful.

The temperature spectrum resulting from the data appears valid to frequencies greater than 20 Hz.

The thermistor is a reliable and accurate instrument if not physically abused. It is not prone to drift.

The magnitude of the temperature fluctuations was larger than expected. Analysis of the records however, lends confidence in their validity.

There is a quasi-periodic component and a random component in the fluctuating temperature. The periodic component correlates with the wave record. This is in agreement with results reported by Makova [1963] in tests conducted at sea. The correlation between wave height and temperature fluctuations of the floating thermistor is greater when wave height is great enough for the thermistor to sample temperatures in the lee of the waves.

The shape of the isotherms over the waves surface, as deduced from the data, appear consistent with the wind velocity profile over waves proposed in Miles hypothesis of wind wave generation [Stewart, 1967].

The temperature range measured by the thermistors is attenuated rapidly with height above the waves.

## VI. RECOMMENDATIONS FOR FURTHER RESEARCH

A. Collection of data over the surface of Roberts Lake should be continued. The small fetch, and small waves make possible the collection of data under widely varied conditions of wind, air-sea stability, wave heights, etc. The situations encountered mirror to some extent the conditions of air-sea interaction over the ocean, but on a more easily observed micro-scale and provide interface studies at low cost.

B. Three or more thermistors mounted at fixed heights could supply information on the rate of isotherm curvature attenuation with height.

C. The feasibility of using thermistors with a faster response should be considered. Although only small energy levels are expected above 20 Hz, finer resolution of the spectrum can be achieved.

D. Identical arrays of thermistors separated horizontally may possibly show similarities or significant relationships with the vertical arrays.

E. A more sophisticated wave gauge circuit is necessary. The 7 cm of linearity obtained by the gauge used was only marginally suitable for the relatively high waves encountered in this research.

F. The circuits should be rewired by qualified technicians. The authors' talents at electronic fabrication are

deficient. "Cleaning up" the wiring will markedly reduce the noise present in the signal, and will reduce the amount of filtering necessary.

G. Approximately 40 minutes of data were collected during runs two and three. Only 192 seconds were analyzed. Other appropriate sections should be investigated.

H. Co-and Quadrature spectra will yield the coherence function and thereby reveal the frequency correlation of the records.

Auto correlation computed for different "start" times for the same record can verify the "assumed" stationary conditions.

I. Analysis of a larger sample (at least 3 minutes) with the resulting auto and cross correlation functions might possibly confirm that a periodic component remains as the time lag is increased beyond 7 seconds.

J. The frequency response function of the thermistor circuit could be used to investigate the effect of the phase shift on the computed power spectrum and cross correlation of thermistors with the wave gauge.

## BIBLIOGRAPHY

1. Batchelor, G. K., "Small Scale Variations of Connected Quantities Like Temperature in a Turbulent Fluid." Journal of Fluid Mechanics, Vol. 5, pp. 113-133, 1959.
2. Bendat and Piersol, Measurement and Analysis of Random Data, Wiley Publications, New York, N. Y., 1966.
3. Cook, J. C. and Kenyon, K. E., "Fast Response Thermistors for Temperature Microstructure Studies at Sea." Review of Scientific Instruments, Vol. 34, Nr. 5, pp. 496-499.
4. Farmer, H. G., "A Data Acquisition and Reduction System for Wave Measurements," Proceeding of Conference on Ocean Wave Spectra, Prentice Hall, Englewood Cliffs, N. J., 1963.
5. Makova, V. I., "Relation Between the Atmospheric Turbulence Spectra in the Lower Levels over the Sea and the Spectrum of Surface Waves," OKEANOLOGIA, Vol. 5, Nr. 4, pp. 592-605, 1963.
6. Pearlman, F., "Dynamic Calibration of Wave Probes" MIT, Dept of Naval Architecture and M. E., report prepared under Contract DSR 6913, sponsored by SNAME.
7. Post, J. L., "Analysis and Synthesis of a Time Limited Complex Waveform." Unpublished Master's Thesis, Naval Postgraduate School, Monterey, Calif., Dec. 1968.
8. Priestley, C. H. B., Turbulent Transfer in Lower Atmosphere, University of Chicago Press, 1959.
9. Rasmussen, R. A., "Application of Thermistors to Measurements in Moving Fluids," Review of Scientific Instruments, Vol. 33, No. 1, 1961.
10. Saunders, P. M., "The Temperature at the Ocean Air Interface," Journal of Atmospheric Science, Vol. 24, Pt. 4, pp. 269-273, 1967.
11. Schooley, A. H., "Temperature Difference Near Air Sea Interface," Journal of Marine Research, Vol. 25, No. 1, pp. 60-68, 1967.
12. Stewart, R. W., "Mechanics of Air Sea Interface," Physics of Fluids, Supp., 1967.
13. IEEE Transactions on Audio and Electroacoustics, June 1967.

INITIAL DISTRIBUTION LIST

	No. Copies
1. Defense Documentation Center Cameron Station Alexandria, Virginia 22314	20
2. Library Naval Postgraduate School Monterey, California 93940	2
3. Naval Weather Service Command Washington Navy Yard Washington, D. C. 20390	1
4. Director, Naval Research Laboratory Attn: Tech. Service Info. Officer Washington, D. C. 20390	1
5. Department of Oceanography, Code 58 Naval Postgraduate School Monterey, California 93940	3
6. Department of Meteorology, Code 51 Naval Postgraduate School Monterey, California 93940	1
7. Oceanographer of the Navy The Madison Building 732 N. Washington Street Alexandria, Virginia 22314	1
8. Naval Oceanographic Office Attn: Library Washington, D. C. 20390	1
9. National Oceanographic Data Center Washington, D. C. 20390	1
10. Director, Maury Center for Ocean Sciences Naval Research Laboratory Washington, D. C. 20390	1
11. Professor Noel E. Boston Department of Oceanography Naval Postgraduate School Monterey, California 93940	10
12. Dr. Karl Woehler Department of Physics Naval Postgraduate School Monterey, California 93940	1

13. Professor Warren E. Denner 1  
Department of Oceanography  
Naval Postgraduate School  
Monterey, California 93940
14. LCDR E. T. Young, USN 3  
USS HARDHEAD (SS 365)  
c/o FPO, New York, N. Y. 09501
15. CDR J. R. Ramzy, USN 3  
USN Submarine School  
Submarine Base  
Groton, Connecticut 06340

DOCUMENT CONTROL DATA - R & D

(Security classification of title, body of abstract and indexing annotation must be entered when the overall report is classified)

1. ORIGINATING ACTIVITY (Corporate author) Naval Postgraduate School Monterey, California 93940		2a. REPORT SECURITY CLASSIFICATION Unclassified	
		2b. GROUP	
3. REPORT TITLE INVESTIGATION OF TEMPERATURE FLUCTUATIONS NEAR THE AIR-SEA INTERFACE			
4. DESCRIPTIVE NOTES (Type of report and, inclusive dates) Master's Thesis; December 1968			
5. AUTHOR(S) (First name, middle initial, last name) James R. Ramzy, Commander, United States Navy Ernest T. Young, Jr., Lieutenant Commander, United States Navy			
6. REPORT DATE December 1968		7a. TOTAL NO. OF PAGES 87	7b. NO. OF REFS 13
8a. CONTRACT OR GRANT NO.		9a. ORIGINATOR'S REPORT NUMBER(S)	
b. PROJECT NO.			
c.		9b. OTHER REPORT NO(S) (Any other numbers that may be assigned this report)	
d.			
10. DISTRIBUTION STATEMENT Distribution of this document is unlimited.			
11. SUPPLEMENTARY NOTES		12. SPONSORING MILITARY ACTIVITY Naval Postgraduate School Monterey, California 93940	
13. ABSTRACT Measurements of air temperature fluctuations as close as 2.5 cm above the surface of a pond in the presence of wind generated waves were made. Fast response thermistors were used, one at constant absolute height and one mounted on a styrofoam float. Data were collected on an Ampex CP-100 tape recorder using FM record amplifiers and a tape speed of 1 and 7/8 ips. The data were digitized by an SDS-9300 hybrid computer and analyzed by an IBM 360/67 digital computer. Temperature fluctuations as large as 5°C in as little as 0.2 seconds were observed with the float mounted thermistor. There was strong correlation between the fixed and floating thermistor readings, with the fluctuation amplitude of the floating thermistor being more than three times larger than the fluctuation amplitude for the fixed thermistor. This ratio decreased when the height of the float mounted thermistor was raised. Signal analysis revealed periodic components of temperature fluctuations associated with the wave action. The large fluctuations measured by the floating thermistor are believed to be caused by the vertical motion of the thermistor in a large vertical temperature gradient immediately above the sea surface. More detailed instrumentation is needed to confirm this hypothesis.			

14 KEY WORDS	LINK A		LINK B		LINK C	
	ROLE	WT	ROLE	WT	ROLE	WT
DATA ANALYSIS FLUCTUATION CIRCUIT						

Thesis  
R202  
c.2

116341

Ramzy

Investigation of  
temperature fluctu-  
ations near the  
air-sea interface.

Thesis  
R202  
c.2

116341

Ramzy

Investigation of  
temperature fluctu-  
ations near the  
air-sea interface.

thesR202

Investigation of temperature fluctuation



3 2768 002 05276 3

DUDLEY KNOX LIBRARY