



**Calhoun: The NPS Institutional Archive**  
**DSpace Repository**

---

NPS Scholarship

Theses

---

2004-06

Marketing plan for the Naval Postgraduate  
School Master of Business Administration to  
the Navy unrestricted line community

Lertangtam, Issares; Trevino, Luis R.; Viera, Nick

Monterey, CA; Naval Postgraduate School

---

<https://hdl.handle.net/10945/9942>

---

Copyright is reserved by the copyright owner.

*Downloaded from NPS Archive: Calhoun*



Calhoun is the Naval Postgraduate School's public access digital repository for research materials and institutional publications created by the NPS community. Calhoun is named for Professor of Mathematics Guy K. Calhoun, NPS's first appointed -- and published -- scholarly author.

**Dudley Knox Library / Naval Postgraduate School**  
**411 Dyer Road / 1 University Circle**  
**Monterey, California USA 93943**

<http://www.nps.edu/library>



# NAVAL POSTGRADUATE SCHOOL

MONTEREY, CALIFORNIA

---

## MBA PROFESSIONAL REPORT

---

**Marketing Plan for the Naval Postgraduate School  
Master of Business Administration  
to the Navy Unrestricted Line Community**

---

**By: R. Luis Trevino, United States Navy  
Issares Lertangtam, Royal Thai Navy  
Nick Viera, United States Navy**

**June 2004**

**Advisors: Becky Jones  
Doug Moses**

*Approved for public release; distribution is unlimited.*

THIS PAGE INTENTIONALLY LEFT BLANK

<b>REPORT DOCUMENTATION PAGE</b>			<i>Form Approved OMB No. 0704-0188</i>	
Public reporting burden for this collection of information is estimated to average 1 hour per response, including the time for reviewing instruction, searching existing data sources, gathering and maintaining the data needed, and completing and reviewing the collection of information. Send comments regarding this burden estimate or any other aspect of this collection of information, including suggestions for reducing this burden, to Washington headquarters Services, Directorate for Information Operations and Reports, 1215 Jefferson Davis Highway, Suite 1204, Arlington, VA 22202-4302, and to the Office of Management and Budget, Paperwork Reduction Project (0704-0188) Washington DC 20503.				
<b>1. AGENCY USE ONLY (Leave blank)</b>		<b>2. REPORT DATE</b> June 2004	<b>3. REPORT TYPE AND DATES COVERED</b> MBA Professional Report	
<b>4. TITLE AND SUBTITLE:</b> Marketing Plan for the NPS-MBA to the Navy Unrestricted Line Community			<b>5. FUNDING NUMBERS</b>	
<b>6. AUTHOR(S)</b> LCDR R. Luis Trevino, LT Issares Lertangtam, LT Nick Viera				
<b>7. PERFORMING ORGANIZATION NAME(S) AND ADDRESS(ES)</b> Naval Postgraduate School Monterey, CA 93943-5000			<b>8. PERFORMING ORGANIZATION REPORT NUMBER</b>	
<b>9. SPONSORING / MONITORING AGENCY NAME(S) AND ADDRESS(ES)</b> N/A			<b>10. SPONSORING / MONITORING AGENCY REPORT NUMBER</b>	
<b>11. SUPPLEMENTARY NOTES</b> The views expressed in this report are those of the author(s) and do not reflect the official policy or position of the Department of Defense or the U.S. Government.				
<b>12a. DISTRIBUTION / AVAILABILITY STATEMENT</b> Approved for public release; distribution is unlimited.			<b>12b. DISTRIBUTION CODE</b>	
<b>13. ABSTRACT (maximum 200 words)</b> The purpose of this Master of Business Administration (MBA) project is to develop a practical marketing plan to attract U.S. Navy Unrestricted Line (URL) officers to the resident Naval Postgraduate School (NPS) Defense-Focused MBA. The intent of this project is to create awareness in the Navy Unrestricted Line community about the benefits of the Defense-focused MBA and to build a brand name for the Naval Postgraduate School MBA (NPS-MBA). The goal is to make the resident NPS-MBA the graduate business school product of choice. The authors believe that the MBA degree provides URL officers the business tools required to become successful managers in the modern naval establishment. The starting point of this project was to conduct a present situation analysis of the MBA degree by determining its strengths, weaknesses, opportunities and threats. It was noted that there is a decreasing number of URL officers in the NPS-MBA program since its inception in January 2002. Although graduate education is a strategic goal for Navy officers, it was found that current URL career progression does not provide an adequate time for resident graduate education. In addition, a fleet survey was conducted to assess URL attitudes toward the NPS-MBA in order to ascertain their awareness levels, which would enable the authors to arrive at effective marketing strategies and recommendations. The survey was conducted in a fleet concentrated area in San Diego, California in March of 2004. Based on the research, there is a need for boosting awareness of the program with a marketing plan that identifies strategies and distribution channels. In addition, research suggests that further marketing to operational commands, hardware commands and detailers, is essential for lobbying Navy URL officers to join the resident NPS-MBA program. Thus, in order to fulfill those needs, a practical marketing plan for the resident NPS-MBA to Navy URL officers is created.				
<b>14. SUBJECT TERMS</b> Marketing Plan, MBA, MBA Professional Report, Marketing Plan for Defense-Focused MBA, Marketing Plan to URL Community			<b>15. NUMBER OF PAGES</b> 87	
			<b>16. PRICE CODE</b>	
<b>17. SECURITY CLASSIFICATION OF REPORT</b> Unclassified	<b>18. SECURITY CLASSIFICATION OF THIS PAGE</b> Unclassified	<b>19. SECURITY CLASSIFICATION OF ABSTRACT</b> Unclassified	<b>20. LIMITATION OF ABSTRACT</b> UL	

THIS PAGE INTENTIONALLY LEFT BLANK

Approved for public release; distribution is unlimited.

**MARKETING PLAN FOR THE NAVAL POSTGRADUATE SCHOOL MASTER  
OF BUSINESS ADMINISTRATION TO THE NAVY UNRESTRICTED LINE  
COMMUNITY**

Luis Trevino, Lieutenant Commander, United States Navy  
Issares Lertangtam, Lieutenant, Royal Thai Navy  
Nick Viera, Lieutenant, United States Navy

Submitted in partial fulfillment of the requirements for the degree of

**MASTER OF BUSINESS ADMINISTRATION**

from the

**NAVAL POSTGRADUATE SCHOOL  
June 2004**

Authors:

\_\_\_\_\_  
R. Luis Trevino

\_\_\_\_\_  
Issares Lertangtam

\_\_\_\_\_  
Nick Viera

Approved by:

\_\_\_\_\_  
Becky Jones, Lead Advisor

\_\_\_\_\_  
Doug Moses, Support Advisor

\_\_\_\_\_  
Douglas A. Brook, Dean  
Graduate School of Business and Public Policy

THIS PAGE INTENTIONALLY LEFT BLANK

# **MARKETING PLAN FOR THE NAVAL POSTGRADUATE SCHOOL MASTER OF BUSINESS ADMINISTRATION TO THE NAVY UNRESTRICTED LINE COMMUNITY**

## **ABSTRACT**

The purpose of this Master of Business Administration (MBA) project is to develop a practical marketing plan to attract U.S. Navy Unrestricted Line (URL) officers to the resident Naval Postgraduate School Defense-Focused MBA (NPS-MBA). The intent of this project is to create awareness in the Navy URL community about the benefits of the Defense-focused MBA and to build a brand name for NPS-MBA. The goal is to make the resident NPS-MBA the graduate business school product of choice. The authors believe that the MBA degree provides URL officers the business tools required to become successful managers in the modern naval establishment.

The origin of this project was to conduct a present situation analysis of the NPS-MBA degree by determining its strengths, weaknesses, opportunities and threats. It was noted that there is a decreasing number of URL officers in the NPS-MBA program since its inception in January 2002. Although graduate education is a strategic goal for Navy officers, it was found that current URL career progression does not provide an adequate time for resident graduate education. In addition, a fleet survey, conducted in a fleet concentrated area in San Diego, California in March of 2004, reveals URL officers' awareness and attitudes toward NPS-MBA. This information enables the authors to later arrive at effective marketing strategies and recommendations.

Based on the research, there is a need for boosting awareness of the program with a marketing plan that identifies strategies and distribution channels. In addition, research suggests that further marketing to operational commands, hardware commands and detailers, is essential for lobbying Navy URL officers to join the resident NPS-MBA. Thus, in order to fulfill those needs, a practical marketing plan for the resident NPS-MBA to Navy URL officers is created.

THIS PAGE INTENTIONALLY LEFT BLANK

# TABLE OF CONTENTS

<b>EXECUTIVE SUMMARY .....</b>	<b>1</b>
<b>I. BACKGROUND .....</b>	<b>3</b>
<b>A. PROJECT BACKGROUND.....</b>	<b>3</b>
<b>B. PROJECT IDEAS.....</b>	<b>4</b>
<b>C. PRODUCT'S CHARACTERISTICS .....</b>	<b>5</b>
1. Size of Organization.....	5
2. Current Products/Services .....	5
3. The Mission of BPP.....	8
4. Marketing Objectives .....	8
<b>II. SITUATION ANALYSIS.....</b>	<b>9</b>
<b>A. MARKET CHARACTERISTICS.....</b>	<b>9</b>
1. Market Demographics .....	9
2. Market-Product Relation .....	10
3. Market Career Paths .....	11
<b>B. MARKET NEEDS .....</b>	<b>15</b>
<b>C. MARKET TRENDS .....</b>	<b>17</b>
<b>D. SWOT ANALYSIS .....</b>	<b>22</b>
1. Strengths .....	22
2. Weaknesses .....	27
3. Opportunities.....	30
4. Threats .....	32
<b>E. COMPETITIVE ANALYSIS .....</b>	<b>34</b>
1. Troy State MBA .....	35
2. Executive MBA (EMBA).....	38
<b>III. AWARENESS AND ATTITUDES OF TARGET MARKET .....</b>	<b>41</b>
<b>A. AWARENESS OF TARGET MARKET TOWARD THE PRODUCT ...</b>	<b>41</b>
1. Awareness of URL Community Toward NPS-MBA .....	41
2. Existing Distribution Channels.....	42
3. Effective Distribution Channels.....	43
<b>B. ATTITUDES OF TARGET MARKET TOWARD THE PRODUCT ....</b>	<b>44</b>
1. Value of Graduate Education .....	44
2. Preferred Education Funding Alternatives.....	44
3. Values of Technical Degree vs. Business Degree.....	45
4. Understanding of the Term “Defense-Focused” MBA.....	45
5. Perception of the Term “Defense-Focused” .....	46
<b>IV. MARKETING STRATEGY .....</b>	<b>47</b>
<b>A. MARKETING MIX.....</b>	<b>47</b>
1. Product.....	47
2. Place .....	48
3. Promotion .....	49

4.	Price.....	50
B.	DEVELOPING MARKETING STRATEGIES.....	50
1.	Use Multiple Channels to Increase Awareness .....	51
2.	Create a Common Theme for the Product .....	51
3.	Create a Unified Marketing Effort.....	51
4.	Maintain Relationship with Key Influencers .....	52
5.	Utilize the Center for Executive Education (CEE) .....	53
6.	Establish NPS-MBA Brand.....	53
V.	RECOMMENDATIONS.....	55
A.	MESSAGES FOR PRODUCT PROMOTION .....	55
B.	PROMOTION CHANNELS.....	57
C.	MARKETING PERFORMANCE EVALUATION .....	63
	APPENDIX (SURVEY QUESTIONS AND RESPONSES) .....	65
	LIST OF REFERENCES.....	69
	INITIAL DISTRIBUTION LIST .....	71

## LIST OF FIGURES

Figure 1.	Average Ratio of URLs to Staff Corps Onboard BPP .....	10
Figure 2.	Average Ratio of URLs to the Rest of U.S. Students Onboard BPP .....	11
Figure 3.	Average Ratio of URLs to All U.S. & International Students Onboard BPP..	11
Figure 4.	Career Path (Surface Warfare Community).....	12
Figure 5.	Career Path (Submarine Warfare Community).....	12
Figure 6.	Career Path (Aviation Community).....	13
Figure 7.	Career Path (Special Operations Community).....	13
Figure 8.	Ratio of URLs to Staff Corps in the first NPS-MBA Graduating Class.....	18
Figure 9.	Ratio of URLs to Staff Corps in the Second NPS-MBA Graduating Class ....	18
Figure 10.	Ratio of URLs to Staff Corps in the Third NPS-MBA Graduating Class .....	19
Figure 11.	Ratio of URLs to Staff Corps in the Forth NPS-MBA Graduating Class .....	19
Figure 12.	Decreasing Trend of URLs in relation to the Navy Enrolling in NPS-MBA ..	20
Figure 13.	Opposite Trend of URLs and Staff Corps Enrolling in NPS-MBA.....	21

THIS PAGE INTENTIONALLY LEFT BLANK

## LIST OF TABLES

Table 1.	Awareness of URLs to the NPS-MBA [After: Ref. 15] .....	42
Table 2.	Existing Distribution Channels [After: Ref. 16] .....	42
Table 3.	Effective Distribution Channels [After: Ref. 17] .....	44
Table 4.	Value of Graduate Education [After: Ref. 18] .....	44
Table 5.	Education Funding Alternatives [After: Ref. 19] .....	45

THIS PAGE INTENTIONALLY LEFT BLANK

## **ACKNOWLEDGEMENTS**

The authors would like to express their deep appreciation to Professor Becky Jones for her guidance, patience and friendship in completing this project. Her positive attitude made this task a “fun” learning experience. The authors would also like to recognize Dr. Doug Moses for his assistance in this project and his dedication to the MBA curriculum. Dr. Moses’ commitment to the program and his devotion to the students have served as an inspirational example.

In addition, the authors would like to thank the troops in Iraq who have protected our freedom while we have had the luxury of learning. Their efforts in the war on terrorism are greatly appreciated and will not be forgotten.

For a strong motivation in completing this project, the authors would like to mention Nicole Viera, Victoria Treviño and Neil Treviño who may one day see this project as an example of quality education. Finally, the authors would like to extend a special thank you to their wives; Amy Treviño, Supreeda Lertangtam, and Vanessa Viera, for their forbearing tolerance to the authors’ preoccupation with this MBA project. Their unfailing support was greatly appreciated.

THIS PAGE INTENTIONALLY LEFT BLANK

## **EXECUTIVE SUMMARY**

The Navy Unrestricted Line (URL) community is the backbone of the U.S. Navy and is presently under-represented in the Defense-Focused MBA program at the School of Business and Public Policy (BPP), Naval Postgraduate School (NPS). The authors believe that URL officers need a business oriented skill set to become successful managers in the modern naval establishment. The authors also believe that the Navy will benefit from educating officers who can think critically and create innovative business solutions to real world problems. However, since the introduction of the first resident Defense-Focused MBA (NPS-MBA) class in January 2002, there has been a decreasing trend in URL officers enrolled in the program. Consequently, this project was completed to develop a practicable marketing plan for the NPS-MBA to create awareness to the URL community.

The project first utilized the analysis of strengths, weaknesses, opportunities and threats (SWOT) to identify the current internal and external environment of the NPS-MBA. Secondly, the project utilized an informal survey, of Submarine Warfare, Surface Warfare and Aviation communities, conducted in San Diego, California to identify the awareness and attitude of URL officers toward the NPS-MBA program. Thirdly, the project exercised a competitive analysis to ascertain the programs offered to URL officers that were in direct competition with the NPS-MBA. Finally, these analyses were combined systematically to create marketing strategies that identify marketing channels for creating awareness of the NPS-MBA brand to the Navy fleet.

In conducting the SWOT analysis, the authors discovered disadvantages of the NPS-MBA; the strong degree completion requirements; the time required away from the operational environment; and the incompatible career paths of URL officers to gain a quality education. However, some advantages were also found. The NPS-MBA is a fully-funded, relevant and high-quality educational product. These advantages of the program should not be overlooked, but rather widely communicated to the URL community.

The informal survey revealed that the chain-of-command and detailers were the strongest influencers in lobbying URL officers to attend the NPS-MBA program. The

URL officers gave much weight in their opinions on these key influencers and often felt that these influencers knew best of how to add value to a Navy career. However, the most insightful discovery was that URL officers did not understand the term “Defense-Focused” as a descriptor of the product. Many felt that the term narrowed the product too much to be marketable in the civilian world. When the term was explained to them, however, URL officers became more comfortable with it and were more willing to participate in the NPS-MBA.

The competitive analysis identified other avenues for URL officers to earn their MBA degree. A comparison to the NPS-MBA was conducted, and advantages and disadvantages of those avenues were identified. It was found that despite many things NPS-MBA can offer to URL officers, other MBA programs may be more appealing to officers who are only concerned with fulfilling their graduate education requirement.

It is apparent that the NPS-MBA program is unique and new. This research suggests that the Navy URL officers are interested in the program but need more information on the program for their decision making process. The NPS-MBA program should appear as URL officers’ best graduate education choice. This project helped identify key issues and targets in the marketing effort of BPP for NPS-MBA.

# **I. BACKGROUND**

## **A. PROJECT BACKGROUND**

As the Navy moves forward into the 21st century, it will face many challenges ahead. The need of naval leaders with the ability to cope with an increasingly complex operational environment arises. The Navy URL officers, the backbone of the Navy, are especially expected to possess the knowledge necessary to manage those challenges. Therefore, it is wise for these URL officers to pursue an education which provides the knowledge of how to run a unit, manage an organization, make a strategy concerning financial, logistics, personnel and every other aspect of the organization in both civilian and military contexts. The Defense-focused MBA program at NPS is considered the best program available to provide the URL officers with those types of knowledge they need. Students enrolling in the program will learn how to become strategic thinkers. The program also encourages both students and faculty to learn from each other's experience to produce an outstanding outcome – Academic Excellence. In spite of a traditional MBA available in many civilian universities, the MBA program focusing additionally on defense related issues, like the one at NPS, is not provided elsewhere in the country. This particular MBA program is highly relevant and needed in the Navy and defense community as a whole.

Against that background, it is noted that many URL officers tend to pursue an education in technical fields, which they think would fit them best as navy officers in a modern naval establishment, without realizing the significance of executive skills. It is also discovered that there has been a decreasing trend in URL officers enrolling in the NPS-MBA. In order to obtain Navy URL officers with executive skills, The Navy in general and the Graduate School of Business and Public Policy (BPP) at NPS in particular, need to provide information on the Defense-Focused MBA program to the Navy URL officers. These officers need to be informed of what is available for them to grow firmly in their military career or even in civilian life.

## **B. PROJECT IDEAS**

The initial goal of this Master of Business Administration (MBA) Application Project was to assist the Graduate School of Business and Public Policy (BPP) in the development of an overall marketing plan that increases the awareness among the Navy URL community for the resident NPS-MBA. The project ideas were proposed as follows:

The purpose of this project is to develop a practicable marketing plan that meets the needs of senior NPS leadership. Moreover, the authors intend to design a marketing plan that captures a strategy and process, and would result in an increased URL officers' enrollment in the resident NPS-MBA program. Output includes:

- Determination of the market size through market research
- Development of a product value proposition through the analysis of Strengths, Weaknesses, Opportunities and Threats (SWOT)
- Definition of marketing channels
- Delivery of a practicable, comprehensive marketing plan

When the project topic was initially conceived, it was noticed that there has been a decreasing number of URL students enrolling in the MBA program relative to the staff corps communities. A ratio of URL officers to staff officers in the first MBA graduating class was 71 to 29 percent. Over time, the number of URL officers has decreased, and, the ratio of URL officers to staff officers in the latest MBA class becomes 40 to 60 percent. Despite this, there was no active marketing plan that outlined a specific strategy to recruit Navy URL officers to the NPS business school.

This MBA marketing project is specifically targeting U.S. Navy URL officers. The report identifies and evaluates marketing issues and provides recommendations and a proposed marketing plan for the NPS-MBA. A review of the existing organizational strategic guidance determined that the BPP has a strategic plan with clear and concise goals including marketing goals, but has no marketing plan for the resident MBA program. Consistency with the organization's overall strategic plan is the most important aspect of this marketing plan. Thus, throughout the process of developing the plan,

reviews of the school's strategic plan were necessary at every step in order to ensure that the marketing strategy was aligned with the strategic direction of the school. Tools of strategic analysis such as SWOT analysis, market positioning, and the marketing mix, were used to assess the organization's external and internal environment, its stakeholders and its current direction. The authors attempted to translate organizational strategy into a plan of action for marketing the resident NPS-MBA.

In order to successfully implement the marketing goals of the school, the authors have developed recommendations to clearly address the stated issues. The authors recommend that those charged with marketing the institution will utilize marketing tactics that are congruent with the strategies in this document. In addition, this MBA professional report primarily focuses on the resident MBA's efforts to target Navy URL officers by looking at the product, the market, and the positioning of the product in the target market, as well as by identifying competition and alternatives to the MBA degree. The resulting marketing plan is a clear plan of action that is consistent with BPP's current goals.

## **C. PRODUCT'S CHARACTERISTICS**

### **1. Size of Organization**

As of quarter one of calendar year 2004, The Naval Postgraduate School (NPS) comprises approximately 1445 students of which 345 are international students. The Graduate School of Business and Public Policy (BPP) consists of 289 resident students studying in 10 curriculums [Ref. 1].

### **2. Current Products/Services**

BPP offers three MBA degree programs to the Department of the Navy (DoN) and Defense community (DoD). The largest program is the full-time resident Defense-Focused MBA program. BPP also offers a part-time nonresident Executive MBA program and a Washington DC-based Joint MBA program. The resident Defense-Focused MBA program provides officers and DoD civilians an advanced education in

interdisciplinary approach to problem solving and policy analysis. Graduates of this program will be able to apply quantitative, financial, economics, information technology, and other state-of-the-art management techniques and concepts to military management and policy issues. The Defense-Focused MBA is a full-time program, resident at NPS in Monterey, lasting 18-21 months. This particular MBA encompasses six major curricula, with specialization tracks within each of them. The six curricula are as follows:

Logistics Management

814	Transportation Management, MBA
819	Supply Chain Management, MBA
827	Material Logistics Support, MBA

Acquisition Management

815	Acquisition and Contract Management, MBA
816	Systems Acquisition Management, MBA

Financial Management

817	Defense Systems Analysis, MBA
837	Financial Management, MBA

Information Management

870	Information Systems Management, MBA
-----	-------------------------------------

Manpower Management

847	Manpower Systems Analysis, MBA/MSM
-----	------------------------------------

Defense Management

818	Defense Systems Management, International MBA
820	Resource Planning and Management for International Defense MBA

[Ref. 2]

Graduates of these curricula are awarded the degree of Master of Business Administration. This degree is accredited by the Association to Advance Collegiate Schools of Business - International (AACSB), and the National Association of Schools of Public Affairs and Administration (NASPAA). The Defense-Focused MBA is a business program that is offered jointly with the Robert H. Smith School of Business and the Naval Postgraduate School. The NPS-MBA endeavors to give future military and civilian leaders the skill set necessary to operate in a complex and demanding environment. Howard Frank, the Dean of the Smith School and former director of the Information Technology Office of the Defense Advanced Research Projects Agency (DARPA), has commented: “The U.S. military is the largest, most complex business in the world, and therefore, all of its senior executives should possess an advanced understanding of commercial practices and procedures” [Ref. 3]. Thus, there has been a need identified in the military establishment that the NPS-MBA fulfills the need of the U.S. military. This type of MBA is essential in the new transformational environment because the curriculum’s structure of the degree benefits both the government and the students. The curriculum consists of courses normally associated with a traditional MBA, but additional classes are provided towards military specialties. Howard Frank further adds, “By combining the Smith School’s world-leading core business curriculum with the defense expertise of the Naval Postgraduate School, we can provide personnel with the unique skills they need to make the military the more efficient and business oriented institution it strives to be” [Ref. 4].

### **3. The Mission of BPP**

- To improve the managerial capabilities and leadership qualities of U.S. and international officers and government civilians through graduate education, research, and professional service.

- To develop students' abilities to analyze, think critically, and take intelligent actions so they can more effectively carry out their professional responsibilities and lead their organizations in complex, and sometimes life-threatening, environment.

- To conduct research that supports military decision making, problem solving, and policy setting, improves administrative processes and organizational effectiveness, contributes knowledge to academic disciplines, and advances the mission of graduate education.

- To provide professional expertise that supports the development of the Naval Postgraduate School, the Departments of the Navy and Defense, and other branches of Government, as well as our professional and academic organizations.

In addition, the NPS strategic plan as a whole stresses:

In particular, we need to provide relevant education to our unrestricted line (URL) officers so they can effectively lead naval operations in the increasingly complex operational environment that is characterized by the explosion of new information and telecommunication technologies, rapidly changing political events, and different levels of military threats. Thus, the strategic goals of the BPP are established to address the URL population decline, and the marketing plan must be congruent with those strategic goals [Ref. 5]

### **4. Marketing Objectives**

The marketing objective for this plan is to recommend strategies that will be implemented by the BBP administration in an effort to promote awareness of the NPS-MBA degree as a valuable educational degree to the Navy URL officers. The authors' intention is to increase the brand awareness of the NPS-MBA. This is especially crucial for the product that is in its introductory phase.

## II. SITUATION ANALYSIS

Situation Analysis comprises five main sections including Market Characteristics, Market Needs, Market Trends, SWOT Analysis, and Competitive Analysis. Market Characteristics provides the general characteristics of the target market including market demographics (rank, educational background), market-product relation (warfare communities in BPP), and market career paths (each warfare community's career path and environment). Market Needs discusses the needs of the market which focuses on how an entity must exist to serve or satisfy the needs of its customers; in this case, how NPS-MBA's existence serves the needs of the URL community and the Navy as a whole. Market Trends discusses the trend of the target market that shows how the URL community has existed in NPS-MBA compared with the Staff Corps and the Navy community as a whole. Then, a SWOT analysis is developed to determine the product's strengths, weaknesses, opportunities and threats, which provide the outlook of how the product is positioned in the market. Finally, competitive analysis provides the more specific insight of how the product is competing against other products in the market.

### A. MARKET CHARACTERISTICS

#### 1. Market Demographics

##### a. *Rank*

Rank acts as a surrogate measure of age, since the age distribution for a given rank is relatively narrow. Rank also acts as a surrogate for career timing which may play a pivotal role in determining a particular target audience. The potential target market in this case is Navy URL junior officers.

##### b. *Educational Background*

Perhaps the most important population characteristic, the educational background of existing and potential markets, is a valuable screening tool. Since NPS offers graduate degrees that require a prerequisite level of education, markets should be screened primarily on this factor. Additionally, the types of educational background

(technical versus non-technical and grades) may yield important information. Examining the educational background of each community helps identify the approximate size of each market in the active duty category. And with the breakdown of the educational background of the URL officer population by rank and service, one could see the eligibility of the Navy URL community in attending graduate education.

## 2. Market-Product Relation

Examining the distribution of URL officers versus Non-URL officers at BPP yields some important insights. Taking the average from the last six years (1998-2003), BPP is comprised of only 30-percent URL Officers and 70-percent Non-URL Officers. When including all U.S. Armed Forces at BPP, the Navy URLs represent 19 percent. In addition, if including all students (U.S. and international) at BPP, the Navy URL representation reduces to only 16 percent of the whole student body at BPP. The pie charts illustrating these percentages are shown as follows:

Figure 1. Average Ratio of URLs to Staff Corps Onboard BPP

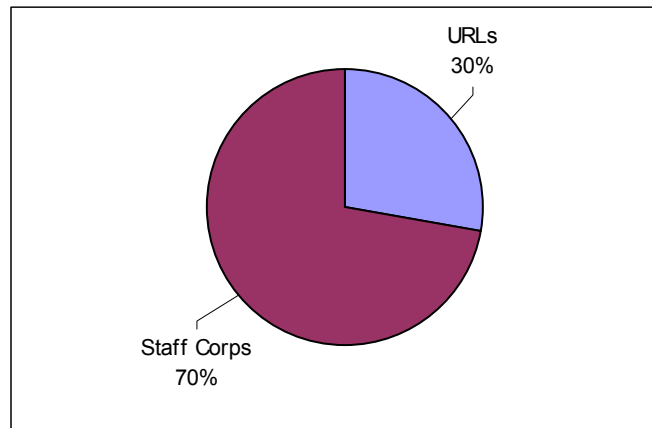

Figure 2. Average Ratio of URLs to the Rest of U.S. Students Onboard BPP

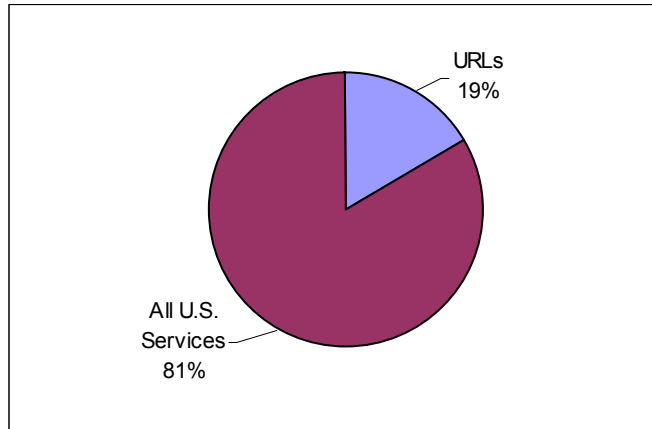
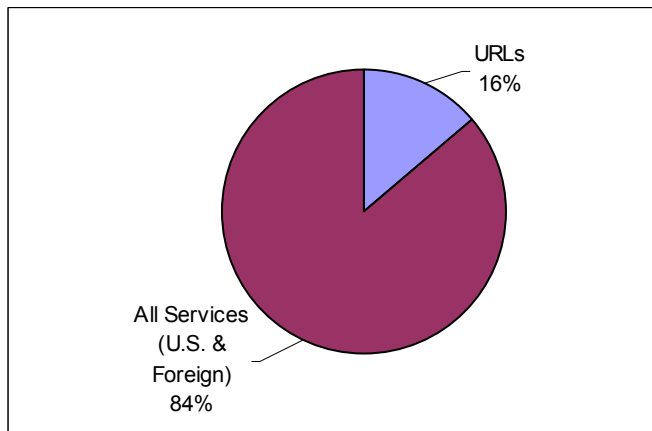

Figure 3. Average Ratio of URLs to All U.S. & International Students Onboard BPP



[Ref. 6]

### 3. Market Career Paths

In order to enter the NPS-MBA program, an officer needs to meet two criteria: the proper educational background and sufficient career timing to complete the program. Since the Surface Warfare, Submarine Warfare, Aviation, and Special Operations communities comprise the bulk of Navy URL officers, examining their career timing paths yields information relevant to marketing the NPS-MBA. The charts demonstrating the URL career path for each URL sub-community are provided as follows.

Figure 4. Career Path (Surface Warfare Community)

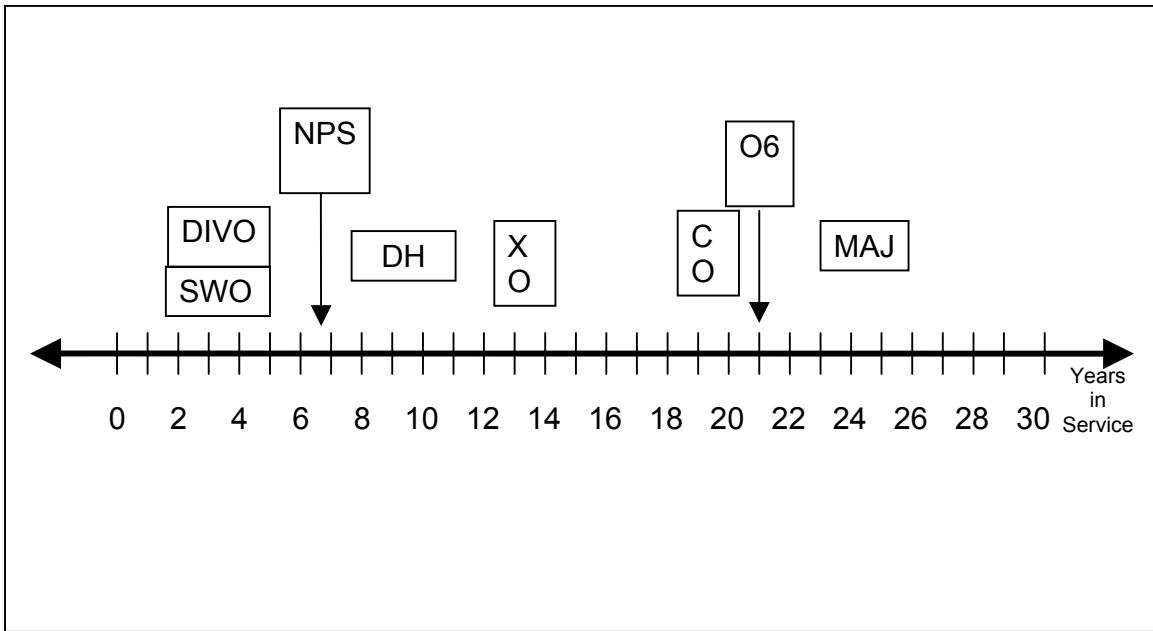

Figure 5. Career Path (Submarine Warfare Community)

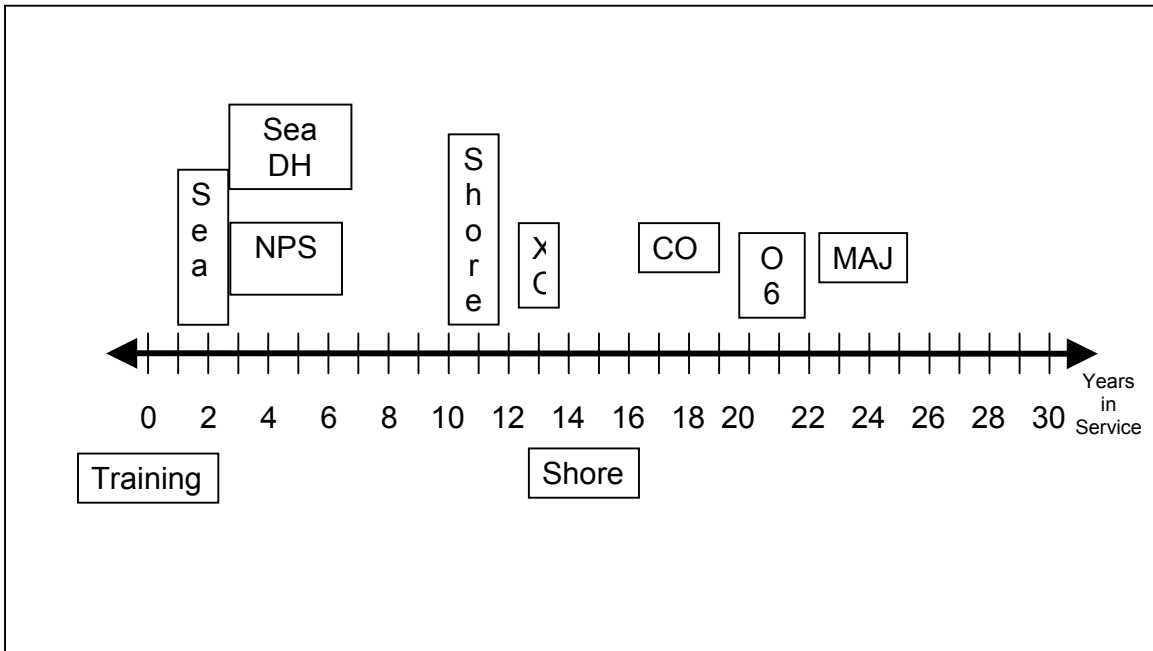

Figure 6. Career Path (Aviation Community)

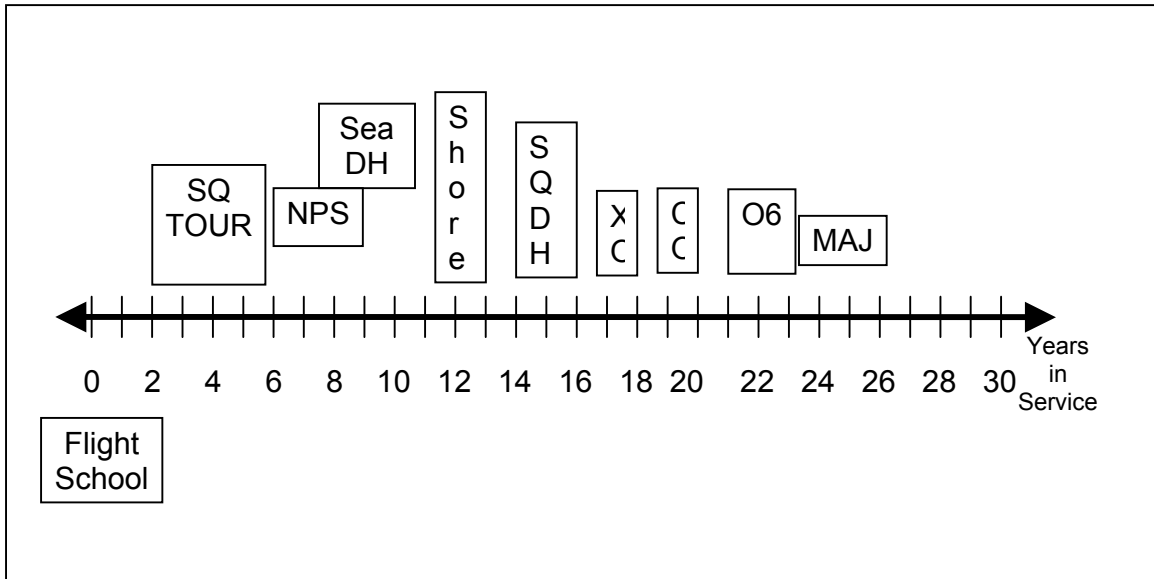
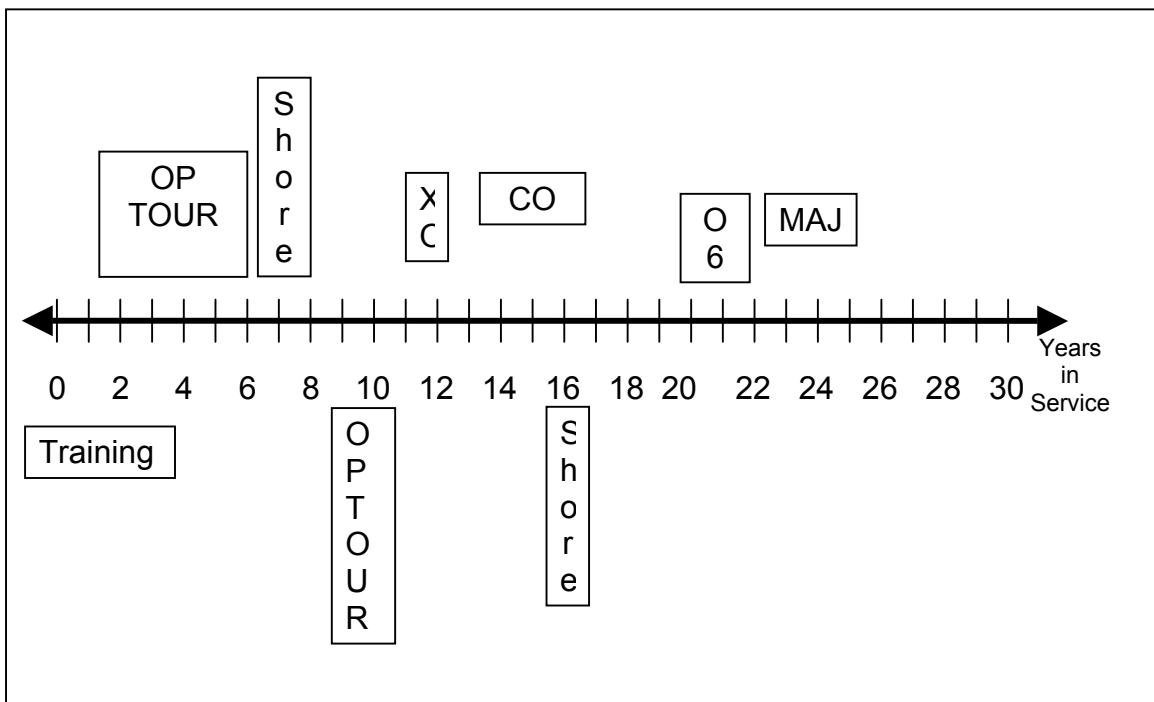

Figure 7. Career Path (Special Operations Community)



[After: Ref. 7]

The previous charts demonstrate that each path is similar to one another in the sense that there are two lengthy (approximately two years) shore tours prior to reaching a command level, with each shore tour following a sea duty or operational assignment. Since officers may make their decision to attend NPS-MBA while on sea duty or at an operational command, it is vital for marketing media to reach surface ships, submarines, aircraft squadrons, Special Ops units, and any deployed units in order to have the greatest impact on potential students.

In discussion with current and former URL officers and their detailers, the authors discover that generally, the surface and submarine community detailers highly emphasize graduate education as the first shore duty opportunity. In contrast, the aviation detailing community does not lay an emphasis on graduate education as the first shore duty opportunity for aviators, but lightly stresses it as the second shore duty option, which is much later in the career path of these officers. An analysis of why each community handles it differently should be considered for further research. However, the authors suggest that possible reasons for the differences may be due to the variation in each URL sub-community environment as follows.

***a. Surface Warfare Environment***

Within six to eight months of initial commissioning, Surface Warfare Officers report to an operational command which is usually challenging and strenuous. An 18-month shore tour away from an operational command provides young career-minded officers the opportunity to pursue graduate education and regroup.

***b. Submarine Warfare Environment***

Upon initial commissioning, Submarine Warfare officers spend approximately a year and a half of training before they report to an operational command. During their nuclear training, Submarine Warfare officers attain technical training that can be applied towards a Master's Degree. Therefore, an 18-month shore tour away from an operational command provides officers the opportunity to complete their degree or pursue graduate education alternatives.

*c. Aviation Environment*

Upon commissioning, Naval Aviators spend approximately two to three years in flight training, which is a majority of their young professional career. Upon successfully completing training, these officers spend the rest of their initial career in operational commands. Following operational commands, aviators are expected to maintain their proficiency in jobs such as being flight instructors. Graduate education appears to be secondary to operational proficiency, and this may offer one explanation of the low number of aviation graduate-education students.

*d. Special Operations Environment*

Upon initial commissioning, Special Operations officers need to complete the basic special warfare training. Upon successful completion of initial training, Special Operations officers report to their first operational tour as platoon commanders for underwater demolition teams or SEAL teams. And only after the second tour as platoon commanders, these officers have the opportunity to pursue a graduate education as shore billets are open for them. The second chance for pursuing graduate education for Special Operations officers is year seventeen in their Navy career. When reaching that stage, it is very unlikely that any of them would decide to join NPS-MBA.

**B. MARKET NEEDS**

BPP exists to serve the needs of the Navy and the DoD. Market needs consider how an entity must exist to serve or satisfy the needs of its customers. BPP customers can be defined as DoD, the Navy, other U.S. military services, international military communities, Department of State, other agencies and the students themselves. It is important for BPP to focus on its various customers' needs and differentiate its products to fulfill those needs.

According to the Superintendent of the Naval Postgraduate School, "if officers are expected to be innovators in the battlefield, then you educate them; and if you want them to replicate, then you train them." Military officers should not only receive functional training in their military fields, but they should also partake in graduate education as a

means to give them the opportunity to think strategically and to be exposed to diverse points of view. In addition, in his 2003 Strategic Guidance, the Chief of Naval Operations (CNO) challenged everyone “to make their great Navy even better by deepening the growth and development of their people and developing innovative operational concepts and abilities.” However, as the Navy moves forward, it is faced with many challenges. Sea Power 21 provides the framework that will enable the Navy to meet these challenges. The framework will require accelerating operational concepts and technologies to improve warfighting effectiveness and enhance homeland security, shaping and educating our forces to operate tomorrow’s fleet. NPS is chartered to increase the combat effectiveness of its students and must also provide education that is relevant to national defense.

The challenge for NPS in general and BPP in particular, is to provide relevant graduate education to Navy URL officers so that they can effectively lead naval operations in an increasingly complex operational environment. The purposes for establishing graduate education programs for military officers are: to raise the levels of individual military officer professionalism, technical competence and executive skills so that those officers can effectively perform their required duties and responsibilities; and to provide developmental incentives for military officers with high ability, dedication, and the capacity for professional growth to remain in the Service.

With those challenges stated by the CNO, the NPS-MBA has a legitimate role in the professional development of URL officers. Presently, the Navy environment is characterized by increasing Operational Tempo (OPTEMPO) and decreasing budgets. With a MBA degree, a URL officer possesses a skill set that solves real world problems, as well as an ability to think strategically and effectively achieve the Navy goals. More specifically, The MBA degree drives individuals to be creative and able to think ‘out of the box’ in time of needs. For example, the Operations Management course teaches the students how to map a process and identify bottleneck in the process. In addition, the Strategy Making course teaches the students how to identify stakeholders and embrace them in a process improvement. Thus, in this transformational milieu, it is imperative that today’s URL officer is able to meet the new terrorist threat with creative solutions.

With that said, BPP and other schools at NPS should embrace and continue to support the leadership and professional development of these officers. The 2001 CNO sponsored leadership summit is a good example of this support. The summit is one of the product offerings that NPS does to help support the URL community. As the external and internal environments of the Navy change with time, the leadership of the Navy needs to change as well. With this in mind, the Navy also realizes the need to provide continued relevant professional development for its top leaders. One way for NPS in general and BPP in particular, to address the needs of Navy URL officers, is to be accessible to all major commands or areas where Navy URL officers are stationed.

### **C. MARKET TRENDS**

Based on the need of the Navy to educate the Navy URL officers to become a business thinkers as discussed in the previous section, the decreasing trend of Navy URL officers attending the resident NPS-MBA – the program designed to produce leaders who can think critically, and are able to solve real world complex problems – caught the attention of BPP senior leadership. The following graphical representations provide the ratios between the URL community and the staff corps community having attended the NPS-MBA. The first pie chart provides the ratio of these two communities enrolling in the MBA program in January 2002; the ratio was found to be 71 to 29 percent. The second pie chart indicates the ratio of the URLs and the Staff Corps to be 48 to 52 percent of enrollment in June 2002. The third chart shows the ratio of enrollment in January 2003 as 35 to 65 percent, and the fourth chart demonstrates 25- to 75-percent ratio of URL and Staff Corps enrollment in June 2003.

Figure 8. Ratio of URLs to Staff Corps in the first NPS-MBA Graduating Class

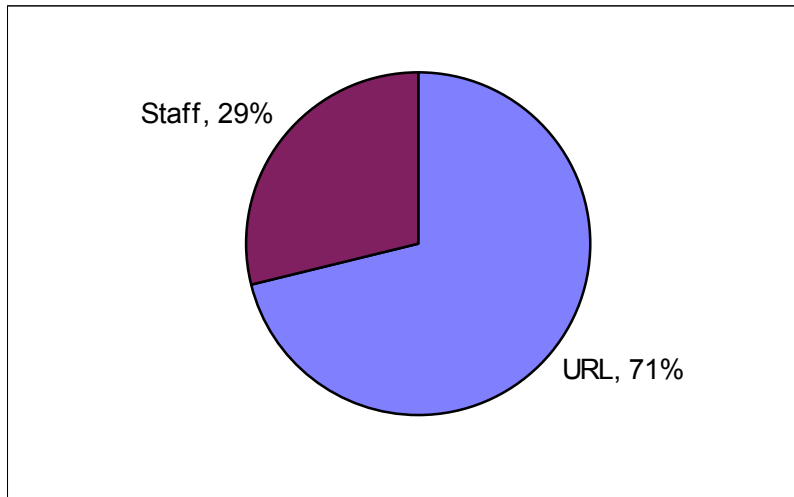

Figure 9. Ratio of URLs to Staff Corps in the Second NPS-MBA Graduating Class

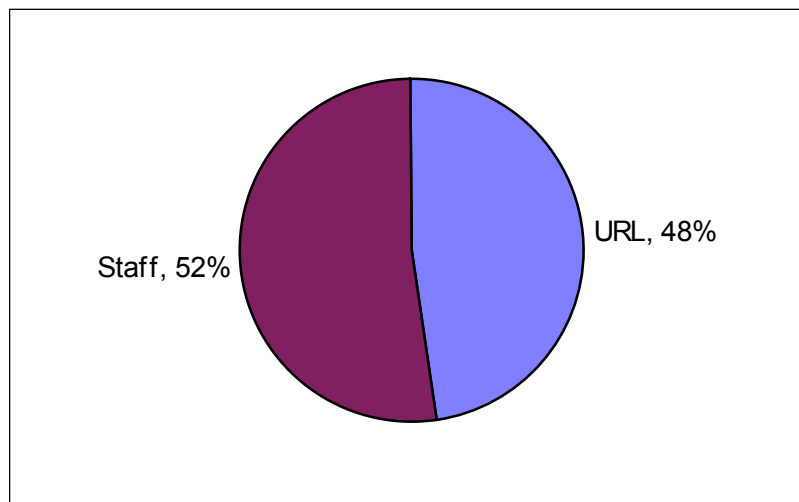

Figure 10. Ratio of URLs to Staff Corps in the Third NPS-MBA Graduating Class

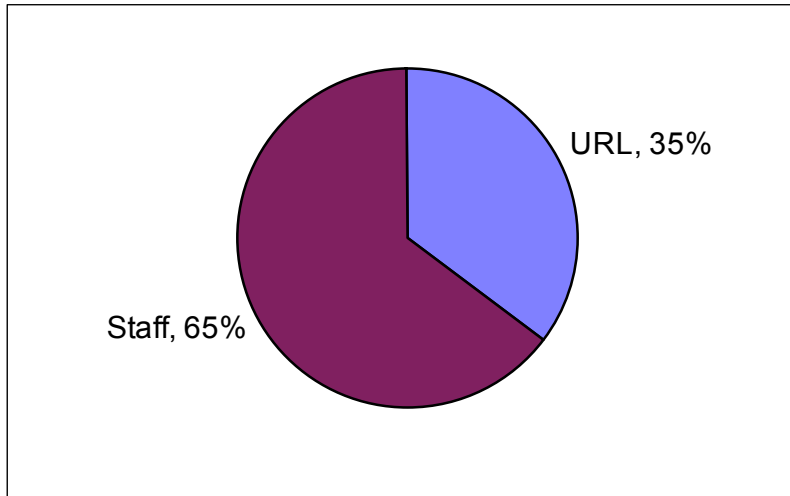
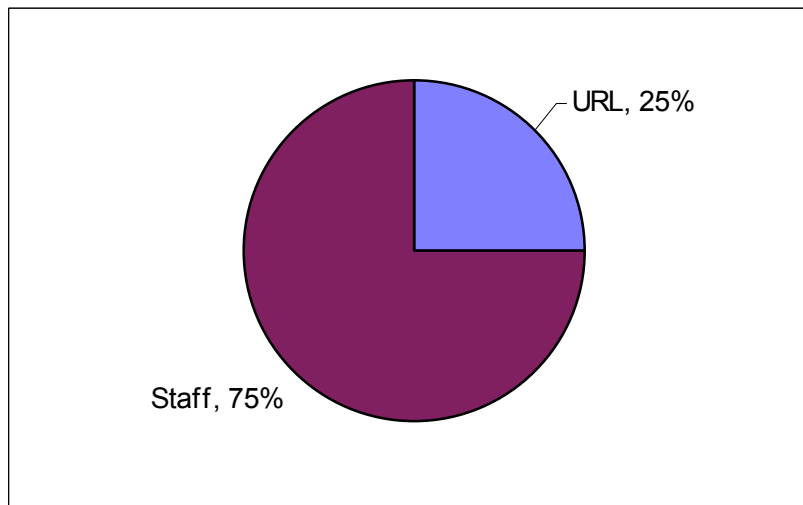

Figure 11. Ratio of URLs to Staff Corps in the Forth NPS-MBA Graduating Class



[Ref. 8]

Based on Figures 8-11, it is clear that the percentage of Navy URLs relative to that of the Navy Staff Corps attending NPS-MBA is decreasing over time. This creates concern for the Navy, NPS and BPP leaderships to look at ways to increase the

percentage of the Navy URL officers enrolling in the resident NPS-MBA. As a consequence, this concern drives the idea of creating a practicable marketing plan to achieve the goal of attracting URL officers to BPP.

In addition to the pie charts, the decreasing trend of the Navy URLs attending NPS-MBA relevant to that of the Navy community as a whole is displayed. This graph provides the more in-depth relationship of how the number of URL community is decreasing in relation to the Navy. Also, the opposite trends of URL and Staff Communities' enrollments in NPS-MBA are presented. These illustrations are provided in Figure 11 and 12 with the trends shown in absolute number.

Figure 12. Decreasing Trend of URLs in relation to the Navy Enrolling in NPS-MBA

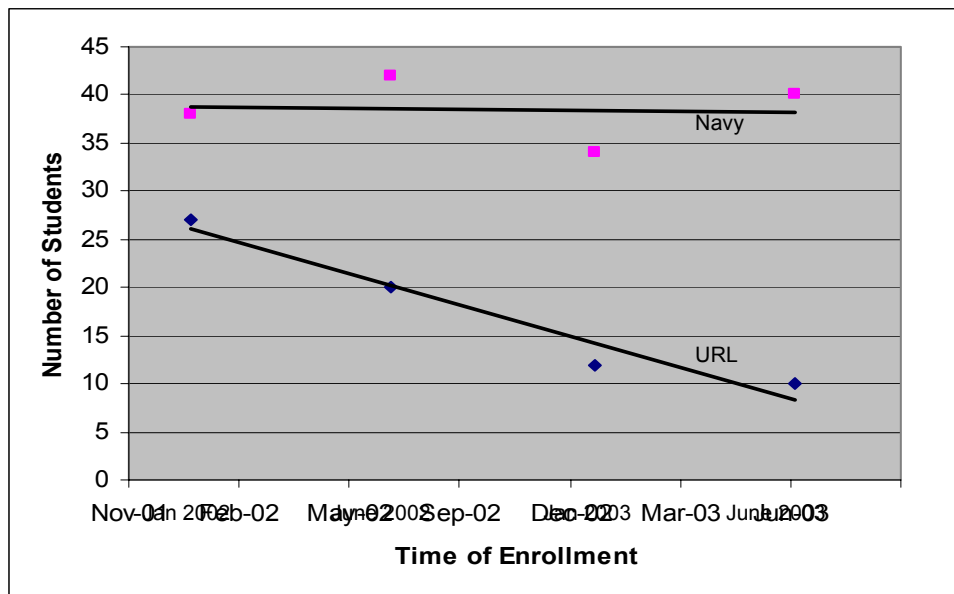
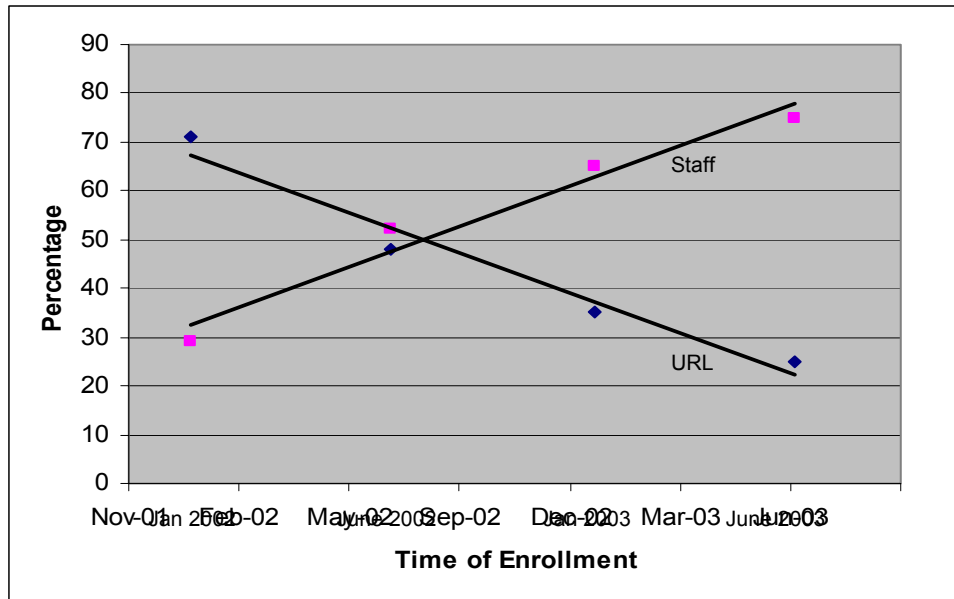

Figure 13. Opposite Trend of URLS and Staff Corps Enrolling in NPS-MBA



[Ref. 9]

Based on Figure 12, one can see the relative constant in the Navy enrollment while URL enrollment declined significantly. This is obvious that the enrollment of the Staff Corps community has risen, which is demonstrated in Figure 13.

Apart from considering NPS-MBA as an alternative for graduate education, many Navy URL officers, in general, try to receive their master's degree by other means such as part-time degree programs or online sources. There is a growing trend of mid-grade URL officers who are enrolling in part-time MBA or executive-type programs available in the fleet concentrated areas, to remain competitive with their peers. Examples include Troy State University, Embry-Riddle Aeronautical University, and Phoenix University. This reinforces the idea that for the URL officers, receiving a graduate education is a significant milestone to remain competitive in the long run.

One important market trend that could have a major effect on the enrollment of the resident MBA program is the increased OPTEMPO in the wake of the global war on terrorism. Operational units would encourage a large number of URL officers to go on deployments, and that could reduce the opportunities for postgraduate education of the

URL community. Consequently, in order to understand the value of the MBA program to the modern naval establishment, these URL officers need to be informed of the usefulness of executive thinking in many levels in operational fields. In addition, these officers need to be further encouraged that the MBA program is a key to a success in their next tour regardless of the mission and location of the deployment.

#### **D. SWOT ANALYSIS**

A SWOT (Strengths, Weaknesses, Opportunities, and Threats) analysis is a tool for identifying relevant screening criteria and for zeroing in on a feasible strategy. The strengths and weaknesses are those components that are internal to the organization while the opportunities and threats reflect external concerns. The SWOT analysis is used to focus the marketing strategies in a manner that takes advantage of wants of its students who desire graduate education and greater intellectual capital. The challenge is to meet the needs of URL officers, within the needs of the Navy.

##### **1. Strengths**

###### ***a. Fully Funded Education***

The NPS-MBA is a fully funded program where students earn their monthly pay and degree simultaneously. Cost is an important factor that differentiates the MBA at NPS from other MBA programs. Officers attending NPS are full-time students. There are little or no out-of-pocket costs to them. In contrast, other alternate means of receiving a graduate degree require students to bear some out-of-pocket expenses. For example, the Graduate Education Voucher (GEV) program available to U.S. Navy officers grants up to \$20,000 a year (up to a maximum of \$40,000 total) for tuition, but requires the student to incur any expenses beyond that realm. In terms of the cost incurred by attending NPS-MBA, one may argue that the service obligation after graduation for the URL officers, is a real cost. However, for U.S. military officers, virtually all of the

alternate providers of MBA programs require a similar service commitment. Accordingly, attending the MBA at NPS is clearly more cost effective than other MBA programs.

***b. Education Quality***

The quality of the instructors in the Graduate School of Business and Public Policy is outstanding. Each class is taught by a PhD in his/her respective field. In addition, students are exposed to instruction from government employees, retired military officers, and visiting professors from the corporate world and academia. Each of these professors possesses a unique individual experience that is brought into the classroom. Many professors have a mix of civilian and military familiarity and knowledge that enriches the classroom environment. This richness of academic environment ensures the very high quality of the resident MBA at NPS.

***c. Accreditation***

The NPS-MBA degree is accredited by both the Association to Advance Collegiate Schools of Business - International (AACSB), and by the National Association of Schools of Public Affairs and Administration (NASPAA). These accrediting institutions are widely known in the world of academia. Based on the research, many of the prospective students that were surveyed voiced the importance they placed in a program being fully accredited. The value added in having a program accredited gives the student an assurance that the degree earned is a recognized anywhere in the country. However, the value of having these accreditations has not been communicated to prospective students.

***d. Research Capability***

BPP gives students the opportunity to analyze and provide solutions to real world problems in both civilian and military establishment. Students are required to produce an MBA project in order to graduate. This marketing plan is an example of an MBA project that provides students with the knowledge of how to market an organization such as BPP to the Navy fleet. In general, the projects are sponsored by the military establishment in order to find innovative solutions and alternatives to the real world problems. This hands-on experience provided by the program is invaluable.

Moreover, BPP is also a research institution where faculties produce research that enhances the content of classroom instruction. With that, MBA students are introduced to cutting edge ideas in business thinking and are exposed to the future military business transformation. This experience will prove invaluable to the students when confronted with issues in their military careers and in future civilian careers.

*e. Uniqueness and Relevance*

This particular MBA degree is defense-focused providing the Navy graduates the ability to analyze defense-focused challenges, in addition to business challenges in the corporate sector. With NPS-MBA, the students take classes that are offered in a civilian traditional MBA program; however, they are also exposed to classes that are unique to the Department of Defense. This gives students an additional skill set that traditional MBA students do not obtain. This program gives the students flexibility to pursue a civilian career or to seek opportunities in the government/military establishment.

The Department of Defense is a multi-billion dollar institution with the largest budget in the world, and has one of the most important governmental missions in the world. Also, it is a global player on the world stage that needs well rounded officers who will maintain and ensure the United States its military advantage. Moreover, the American military person is the most common representative of the United States to the rest of the world. It is essential that America's military officers are educated in the latest business techniques. Last but more importantly, some billets require the subspecialties students can obtain by attending NPS-MBA.

*f. Greater Chance for Promotion*

There are currently 220 officers that are Admirals in the Navy, with 85 percent of them having a graduate degree. Of those having a graduate degree, 23.5 percent received their Master's Degree from NPS. The NPS is by far the graduate school most recognized in the naval community, especially for advancement to flag rank. The next education institution most represented is the Naval War College with 5 percent of its graduates becoming Navy admirals. Also, of the Admirals who obtained a Master's Degree from NPS, 41 percent earned a business related degree. These results reflect the

value of a business related Master's Degree at NPS as highly recognized on Navy selection boards. This is the strength of NPS-MBA program that must be further communicated to the Navy URL community.

The authors strongly believe that in an environment of decreased funding and increased demands upon the Navy, it is crucial for Navy officers, especially URL community, to possess a business mindset in order to improve efficiencies in modern naval operations. The results of promotion boards support this belief. For every competitive category and grade, Navy officers who have attended NPS-MBA have done better than the fleet average in selection for promotion. In the past, some mentors had advised that time spent attending a postgraduate school was at best a break even position due to not-observed fitness reports received during postgraduate education. A thorough review now shows this as time well spent for career minded officers. Moreover, the latest promotion results show a clear advantage for officers with graduate degrees. For instance, the fiscal year 1997 LCDR promotion rate for officers with fully funded graduate education was 73.1 percent compared to 70.2 percent of the fleet average. Also, the fiscal year 1997 CDR promotion rate for those with fully funded graduate education was 69.9 percent compared to 63.9 percent of the fleet average. Additionally, current Navy leadership strongly feels that it is extremely important for the Navy officer corps to have a graduate education, as stated by the Secretary of the Navy's guidance to promotion results:

Postgraduate education and specialty skills are important to our Navy and represent a key investment in our future. In determining an officer's fitness for promotion, selection boards should consider time spent obtaining postgraduate degrees and military education, and gaining experience in other specialized areas in a positive light, notwithstanding the usual not-observed fitness reports during these periods. Assignment outside the traditional career patterns that allow the Navy to use the unique skills and expertise of these officers in subspecialty areas likewise should be considered as positive [Ref. 10]

Even if an officer's goal is not to achieve a flag rank in the Navy, one should consider the education received from NPS-MBA program as a life event that will serve him/her well regardless of the direction of one's future.

***g. Joint Atmosphere***

This is the first time in a URL officer's career where one is exposed to an international and intra-service community. The military environment is increasingly more united, and, it is imperative that URL officers get this exposure early in their respective careers. NPS in general and BPP in particular, have a diverse student population from all branches of the U.S. armed forces and approximately 45 foreign nations. NPS students are generally composed of Navy, Army, Marine Corps, Coast Guard, and Air Force officers. However, there are some National Guard students, defense civilians, and contractors as part of the community. This diverse student population contributes to a learning environment where students enhance military joint effectiveness through innovation, critical thinking, and research.

***h. Diverse Products***

A student may earn an MBA in many disciplines: Defense Management, Contract Management, Program Management, Financial Management, Logistics Management, Human Resources and Information Systems Management. The diversity of the product opens the opportunity for the URL officers to select what is best for their career. As a result, they would feel that BPP is a high quality school, not amateur, as some tend to perceive.

***i. Simple Admission Process***

The process of recruiting URL officers to the NPS-MBA program and all other curriculums at NPS is important in marketing. Requirement for entry into the NPS-MBA program are less than other schools. Many students accepted to the NPS-MBA would not be given the opportunity elsewhere. The NPS-MBA acknowledges growth as an officer is an important attribute for entry. This is a strength because when a process is not complicated and very welcoming, URL officers in the fleet would be more encouraged to apply for postgraduate degrees at NPS. Admission process generally helps

facilitate military officers to attend graduate program at BPP, NPS. Firstly, there is no requirement to take GRE and GMAT exams to enter the program. Selection of officers for NPS education is based only upon outstanding professional performance, promotion potential and a strong academic background. Moreover, admission process at BPP, NPS has a unique feature of offering enrollment every six months. All these features should be used to target URL officers who are not aware of education opportunity that exists.

*j. Quality of Life*

The school is located in one of the most picturesque areas of the country, Monterey Peninsula. Monterey is known for its great weather, beautiful coast lines, and its world renowned golf courses. This aspect of the area can be promoted in future MBA awareness drive efforts. NPS is within driving distance from major pro-sport attractions and the city of San Francisco. Attending graduate school in Monterey offers a student experiences one may not be able to find at other schools.

**2. Weaknesses**

*a. New Program to the URL Community*

The NPS-MBA was initiated in 2002. Its first graduates earned their degrees in June 2003. Thus, the program can be considered as in its introductory stage, and this may be seen as a weakness because of a lack of awareness in the Navy and civilian sector. A civilian institution is instantly recognized by the reputation of the alumni that graduate and in the requirements that are necessary to attend the school. The NPS-MBA is deficient in both of these aspects. The result from the fleet survey supports this claim (more than half of the samples did not know the existence of NPS-MBA). Because the program is so new, it has no natural ambassadors that can vouch for the quality of education and production of its graduates. The reputation of the graduates will only come in time and after they have successfully proven themselves in a real world environment. The lack of measurable requirements (GMAT) needed to begin the NPS MBA, for Navy URLs, gives it no universally recognized metric. Army students are required to enter GMAT scores to qualify to begin the MBA program. Prospective students use these metrics in order to compare schools and be assured of the quality of education. With this new establishment of the program, the URL officers may perceive

the NPS-MBA as not fully professional compared to other MBA programs (although the actual NPS-MBA program is fully professional with high quality).

***b. Unrecognized Brand in Civilian World***

Prior to going to a shore command, many URL officers look at magazines such as U.S. News and World Report to compare the rankings of graduate universities. Many URL officers can argue that the lack of NPS being mentioned in U.S. News and World Report plays a major factor in considering enrolling for NPS degree in general and the MBA degree in particular. The criteria used by these publications to rank school such as GPA, GMAT, and salary, do not match up with NPS criteria. This is because there are not many channels out there such as ranking, media and corporate portrayal available to compare NPS with other top tier graduate universities.

BPP is not typically ranked among civilian universities because business schools are usually ranked by considering placement of graduates in corporate world. This makes it unrecognized brand in civilian community. Usually, NPS graduates, especially URL officers, do not directly use their degrees in a civilian environment. Rather, they are directly recycled into the operational military. Graduates may not use their MBA degree in a civilian setting for as long as 10 years. As a result, it is difficult and seems irrelevant to compare the value of civilian MBA degree to the one at BPP. This may prevent the Navy establishment or prospective students from regarding the school as a top ranked institution.

***c. Strong Degree Requirements***

Students are required to complete over 90 credit hours to graduate and are taken out of the operational environment to attend the residential program. This may seem as a negative for students who may wish to avoid being labeled not current in their particular warfighting professions. In addition, most civilian institutions require only 45 credit hours to graduate, and this gives students an incentive to gravitate to a school with less workload. In terms of a “check in the box” requirement for military officers, schools that offer an online program or night school a few nights a week seem more attractive.

Based on the above environment, prospective URL students may perceived the NPS-MBA as too heavy a workload and elect to obtain their education at a less strenuous institution.

***d. Operational Requirement Dilemma***

Sending students to NPS translates into taking the officers out of the operational pipeline. Thus, the Navy operational units would not support the idea of sending URLs to attend MBA program at NPS. Furthermore, Navy officers are currently needed around the world, especially when the Navy is supporting campaigns in both Afghanistan and Iraq simultaneously. The increased Operational Tempo (OPTEMPO) may cause a disincentive for the Navy of sacrificing officers who attend school while they can contribute directly to the more urgent need of the Navy.

***e. Negative Perception of Non-Technical Degree***

The fact that the Navy is becoming more technologically driven poses a need for technical minded officers. Therefore, a MBA might not be considered as a degree that will facilitate the operations of technical units. There is likely a perception problem within some parts of the Navy establishment concerning the usefulness of the MBA degree in a highly technical working environment.

***f. Long Commitment***

Attending NPS-MBA requires a commitment from officers for as much as three years. This is a disincentive for officers to pursue a MBA program at NPS due to the fact that it takes away flexibility in deciding on individual goals. A student can attend a night course program and owe nothing back to the Navy. This way, one would have a freedom to leave military service on his/her own timetable.

***g. Perception of NPS-MBA as Immature***

Success in business depends on the initial image portrayed to prospective customers. Based on informal interviews and observations, the current perceptions of NPS vary. For example the International Officers perceive NPS as a place to receive an excellent education to enhance their professional careers, whereas some U.S. military officers view it as a place for officers to relax and enjoy recreational activities such as

golf and sailing, before heading back to an operational command. As a result, the NPS-MBA has the risk of being perceived as less professional compared to other MBA programs at other institutions.

***h. Lack of Visibility***

Based on the results from the survey, it is clear that the NPS-MBA has not been well promoted since its inception in 2002. This lack of promotion puts the program in a difficult position in the market place since the students would prefer to receive the degree that is well known and its information is readily available. It is also evident that the detailers have done a poor job in promoting the NPS-MBA to the Navy URL community even though they are a significant avenue for potential graduate students to obtain information of the products offered at NPS.

**3. Opportunities**

***a. Recruitment Tool to Keep Officers in the Navy***

The Navy could use the incentive of earning a MBA degree to attract excellent officers to stay in the Navy. The basic business elements change little and the MBA is very marketable all over the country. The MBA is flexible enough to be used in multiple career fields and does not tie an individual to a specific industry. These qualities are very desirable to anyone wishing to expand their skill set and increase their marketability. A MBA is a recognizable and marketable degree in the civilian environment. The degree gives the student the tools to think strategically and critically. These are attributes that organizations require in an employee, in order to compete in an increasingly global environment.

Because the MBA degree is generally well known in the civilian world, Navy URL officers would be more inclined to pursue this type of degree to enhance their career opportunity in the future. In addition, a MBA degree keeps its currency longer than some technical degrees.

***b. Away from Intense Operational Environment***

Many Navy URL officers enjoy the break in Operational Tempo, but understand that it can be the detriment of their career. The NPS-MBA has the opportunity

to communicate with detailers to change the career progression in order to ensure promotion. Because NPS is part of the Navy administrative chain of command, it may find opportunities in lobbying the Bureau of personnel in supporting URL students on getting billets they would like. Despite that the Chief of Naval Personnel is serious about educating the Navy officer corps, the officers need assurances of not being penalized for taking time to attend a resident NPS-MBA program.

*c. Joint Education*

Students have the opportunity to earn Joint Professional Military Education (JPME) phase one credit while attending NPS. While MBA students are attending NPS they also have the opportunity to attend classes conducted by The Naval War College. This program develops the students in professional military doctrine and prepares them for responsibilities that are joint in nature. In an increasingly transformational military, JPME will become increasingly more important to the warfighting communities. Without the Cold War, officers are required to change their focus in war planning and are being introduced to transformational concepts as net-centric warfare and combating global terrorism. This has the combined effects of efficiency of time because students can add the JPME to their qualification portfolio and the Navy increases its inventory of eligible officers in any operational theater. This is a win-win situation for the students and the naval service. With that, BPP could put a greater emphasize on this advantage to the URL community and the operational commands respectively.

*d. Publicity within BPP*

One of the NPS major goals is to provide cost effective research and unique laboratory facilities to permit students and faculty to support Navy/DoD needs. These efforts should be effectively publicized to demonstrate relevance. Currently, NPS has published some research efforts to the DoD community. Examples can be found from the PAO office which highlights efforts being made in Computational Cognition, Unmanned Vehicles and Combat Modeling. These efforts are the products of the Graduate School of Engineering and Applied Sciences and the Graduate School of Operational Information Sciences. This is an opportunity of BPP to follow these

examples and communicate its value added research. The following are examples of research done by current BPP students that are of interest to the Navy and other DoD activities.

One interesting research is The International Cooperative Research and Development (ICR&D). This research evaluates the current ICR&D process and makes recommendations to enhance the ICR&D process by examining ICR&D between the U.S. and NATO members: France, Germany, and the United Kingdom. Another research is the Guidance for Navy Contingency Contracting Officers. This research provides guidance by which future U.S. Navy Contingency Contracting officers can effectively prepare for contingency operations. This is especially important in order to enhance the effectiveness of future officers in contingencies around the world.

#### **4. Threats**

##### ***a. Competing Programs***

Officers have other avenues they can tap into to earn a MBA degree. Some competing navy programs that offer officers opportunities to gain an MBA are:

(1) Graduate Education Voucher Program (GEV) – The GEV gives URL officers the opportunity to obtain off duty graduate education while being stationed at a shore command. This program encourages officers to obtain technical degrees by offering more quotas annually for technical degrees. The quotas available for officers pursuing a business degree are as follows:

- International Affairs: Surface-1, Aviation-4
- Financial Management/Accounting: Surface-8, Aviation-6 Submarine-6, SPECOPS-3
- International Finance: Surface-8, Aviation-6, Submarine-5
- Economics: Surface - 8, Aviation - 6, Submarine - 5 [Ref. 11]

The program covers 100 percent of education costs to a maximum of \$20,000 per year for 24 months not to exceed \$40,000. The service obligation consists of 3 months for every one month of education not to exceed 36 months. The GEV is a competitor to the NPS-MBA because by attending it, a student can get his/her graduate degree while still being

able to contribute to the operational navy. The GEV may be a very attractive choice to an officer who may be worried about the diminishing of his operational skills while his competitors are staying current. The resident NPS-MBA costs the navy an asset by taking a war-fighter out of action for 18 months. This GEV program gives more flexibility to the Navy by keeping an officer who will continue to develop his operational skills. The graduate education provided with the GEV can be accomplished on liberty time and does not impact the current needs of the navy.

(2) Tuition Assistance (TA) – TA will pay the maximum of 100% of tuition but will not exceed \$250 per semester hour no to exceed 12 semester hours for the fiscal year. TA cannot be used for the purchase of books and cannot be used for courses already funded using TA [From Ref. 12]. Like the GEV, TA is intended for officers who are interested in attending graduate school on their off time while being assigned to shore duty. The major difference between GEV and TA is that officers using TA can pursue their own chosen field of study and a chosen educational institution. The student can choose to obtain a degree from a top ten university or to attend a university that may not be as reputable but fulfills the requirement of advanced education. GEV does not permit the student this kind of flexibility. Similar to GEV, however, TA results in a 3-year service obligation. Again this is a direct competitor to the NPS-MBA because this assistance offers the student a chance to fulfill operational commitments and degree requirements simultaneously. The NPS-MBA does not offer these types of incentives.

(3) SWO MBA – Each year the surface warfare community sends three qualified Lieutenants to Harvard University, University of Pennsylvania and University of Chicago. The competition for these billets is very intense and GMAT scores are required for consideration. This program is not a major threat to the NPS-MBA but it represents another avenue an officer may wish to choose in order to fulfill his requirement for an advanced degree. This is fully funded education with the benefit of receiving on pay and benefits the Navy has to offer.

(4) Executive MBA (EMBA) – This program gives the student the opportunity to achieve his goal of obtaining his MBA without having to cope with a permanent change of station (PCS) to Monterey, California. The EMBA is only 24-

month long and it only requires the student to go to class once a week. The program is offered in fleet concentrated areas providing a convenience for students to attend. This is a competitor to the NPS-MBA because the student earns an equivalent degree without having to take time from his career path to achieve this goal. In addition, the student can stay operationally current with the added benefit of having fully funded education.

***b. Base Realignment And Closure (BRAC)***

NPS may be threatened by the forced closure of the school, at the same time, there is some chatter that the school may just relocate rather than close. This has implications for the Navy and students; the Navy is not certain whether to continue to support the school as it is currently. URL officers may not be willing to attend the institution considered to be at risk. The risk of BRAC is shared among past, present and future students, faculty and staff. However, if it is certain that NPS will continue to open for a long future, NPS needs to eliminate this perceived instability and promote the high value, of the school immediately.

**E. COMPETITIVE ANALYSIS**

The competitive analysis is to provide a clearer picture of how NPS-MBA stands in the market place relative to other peer MBA programs. In other words, this analysis demonstrates how attractive NPS-MBA is to the Navy URL community compared with other available MBA programs. In order to determine differences among different programs, the authors provide a description and lay out the advantages and disadvantages, of each program compared to the resident NPS-MBA. There are, in fact, many MBA programs in various institutions in which URL officers may attend. However, only two potential competing MBA programs (civilian and military) are selected for the analysis, while other MBA programs may be further analyzed when needed. These two selected programs include MBA at Troy State University and the Executive MBA (EMBA).

## **1. Troy State MBA**

To find out about Troy State MBA, the authors did the followings. First, the authors canvassed Navy Campus office programs fleet wide in order to determine what institutions they were promoting. A Navy Campus is an on-base office that assists prospective students in finding education programs to fit individual needs. The Navy Campus serves enlisted personnel in finding undergraduate programs and assists commissioned officers who are interested in graduate education. The local on-base offices also help educate Navy members in Navy tuition programs by providing information on the matriculation process and the obligation incurred when utilizing navy tuition aid benefits.

In canvassing Navy Campus office programs fleet wide, the authors discover that the Campuses list many alternatives in graduate education programs including MBA programs. The five most frequent MBA programs listed in Navy Campus websites are the Florida Institute of Technology, National University, Troy State University, Webster University and The University of Redlands. Each of these institutions provides part-time or night-school programs that are very attractive to the navy URL community. Among these, Troy State University is selected to be analyzed because it is a program offered in many different fleet concentrated areas such as Washington D.C., Norfolk, VA and Yokosuka, Japan. Moreover, Troy State University offers MBA programs at many Air Force Bases and Army bases around the world.

Troy State University has satellite campuses in five geographic regions and 50 branch offices dispersed among 14 states. The five geographic regions are the Atlantic region, Florida/Western region, Pacific region, Southeast region and International sites. The quality of faculty and the branch curriculums are the joint responsibility of the branch colleges and the main university. The main university controls the admission process, transcript records and degree awarding.

The MBA at Troy State University consists of 36 semester hours, which is equivalent to a 12-course program. This program can be completed in 2 years, but the student has some flexibility in the course load he or she wishes to schedule. The core curriculum courses consist of 6 classes (18 credit hours). The remaining 18 credit hours

are based on the specialization within the MBA degree. The two curricula offered by Troy State University are General Management and Information Systems. The prerequisite to enter the MBA program at this institution is an undergraduate degree in business administration or credits in eight prerequisite classes. In addition, the candidate must have a 2.5 cumulative GPA or a 3.0 or higher in the last 30 hours of undergraduate work. Admission is conditioned on the candidates test scores on standardized tests. The minimum test score requirements include GMAT (450), MAT (33) or GRE (850) [Ref. 13].

*a. Advantages*

Troy State's strongest advantage is its relatively short degree requirement. A student is required only to attend 12 classes (36 credit hours), whereas the NPS-MBA can require as many as 90 hours of class. This short degree requirement at Troy can be very attractive especially to the Navy officer who wishes just to fulfill the requirement for a Master's Degree in order to gain future promotion. This 'check in the box' mentality would result in more officers seeing a part-time civilian institution such as Troy State University as an alternative to NPS. Moreover, the student attending Troy State MBA can relax with a maximum availability of 2-year period to meet all degree requirements. In contrast, the NPS-MBA requires the student to finish the program in 18 months with no realistic opportunity to make an extension. In addition to the timing flexibility, Troy State MBA adds flexibility to the degree plan. The program offers electives that a student can choose. The NPS-MBA courses, on the other hand, are all mandatory and the student has no real electives. The Troy State student can pick and choose when he/she wishes to enroll in classes, and this can be very attractive to a person that has personal issues to accommodate.

Furthermore, due to the fact that Troy State possess offices around the world, an MBA student can transfer from one's current duty station without the need to complete the degree requirements and begin classes again at another branch. The NPS-MBA is offered only in Monterey, CA. If a student wants a NPS-MBA, he/she must attend the resident program with no flexibility in where he/she may attend classes. Finally, the Troy State MBA incurs no obligation for further Naval service, as long as the

student attends courses at one's own expense. This is clear that attending Troy State MBA adds flexibility to the officer if he/she chooses to leave the service after obtaining his/her degree. The NPS-MBA, in contrast, does not give the student this flexibility: all NPS-MBA graduates are obligated to serve some additional years in the Navy.

*b. Disadvantages*

A strong disadvantage in attending a program such as Troy State MBA is that course work is conducted on the individual's off time. This means that a student essentially has two full-time jobs; day job and education, which results in a serious implication. According to regulations, the military service requirement has priority over anything the individual may want to accomplish on his/her off time. In other words, an officer is on duty 24 hours a day, and any military requirement precludes off-duty education. Therefore, in order to attend a part-time or a night-school MBA such as the one at Troy State, a URL officer must be willing to sacrifice the quality of the educational experience in favor of military commitment. On the contrary, the NPS-MBA is the URL officer's duty. The officer attends NPS to be a student and nothing more, so all his/her time is dedicated to learning. Attending NPS-MBA clearly gives an officer the opportunity to fully learn academic materials without having to deal with any distractions from military commitment.

Another disadvantage of Troy State MBA is that a student has no ability to network with fellow military officers. Although, the student body at Troy State is very diverse in nature with civilian students from a range of occupations and backgrounds, these people will not serve with a URL officer in the immediate future. On the other hand, the NPS-MBA provides a URL student an opportunity to meet officers from other U.S. armed services and foreign military services to whom he/she may serve with in the future.

The final disadvantage of Troy State MBA is that it is tailored after the needs of the civilian workforce, and there is no additional military qualification that an officer can earn while attending. On the other hand, the officers who attend NPS-MBA can take the advantages of a traditional MBA while further qualifying themselves as

officers in a military subspecialty. In addition, whether the URL officers wish to stay in the military or pursue a civilian career, the NPS-MBA gives them the types of knowledge they need in both military and civilian environments. Dissimilar to NPS-MBA, Troy State MBA takes the URL officer out of the military establishment, and as a consequence, he/she is out of touch with the current news of the military and is not privy to the most current solutions to military problems and issues.

This is apparent that although Troy State University is a well known educational institution, it does not have the same name-recognition that the Naval Postgraduate School possesses within the U.S. military. An MBA program from an institution such as Troy State University has a disadvantage in distinguishing itself from other MBA programs at any other civilian business schools in the country and does not hold the highest of reputations for quality education.

## **2. Executive MBA (EMBA)**

The Executive MBA (EMBA) is one of NPS sponsored programs. The EMBA is chosen as a competitor to the resident NPS-MBA because it gives the navy URL officers another option for attending a resident MBA program in local areas in which they are stationed. The EMBA is offered in some commands as a part-time program. It is a 24-month curriculum that has a requirement of only 54-credit hours. EMBA core classes make up 37 hours of the degree, while the rest of the credits are electives. In order for a URL officer to be admitted into the program he/she needs to meet only a few requirements as described below:

- LCDR or above
- Department Head tour completion
- Undergraduate Degree
- 245 APC and 2.6 GPA as minimum

### ***a. Advantages***

A strong advantage for the EMBA is that it is a defense-focused curriculum like the NPS-MBA, which a URL student can attend without having to transfer to Monterey. The principals and issues discussed and researched in the program

are the same ones being pursued in Monterey. In addition to the convenience the student can receive, the EMBA course work is not as demanding as the resident NPS-MBA, which gives more time for the student to complete. Moreover, although taking courses elsewhere, the student earns his/her degree from the home campus of Naval Postgraduate School in Monterey where his/her accomplishment may be recognized fleet wide.

Apart from that, the faculty who teach the EMBA program are professors with extensive experience in civilian and military circles. The program generally requires that each faculty member pursue research in the improvement of the defense establishment. Also, many professors are prior military personnel who have a sense for the URL officer's educational needs. As a result, the program takes great pride in the quality of its faculty and education.

The EMBA gives the URL much needed flexibility. As a part time program, the EMBA allows a student to keep operational proficiency while obtaining a goal of gaining educational experience that will further his/her personal career. The student does not have to cope with a permanent change of station which comes with the inconvenience of having to relocate one's family [Ref. 13].

***b. Disadvantages***

A strong disadvantage of the EMBA to the resident NPS-MBA is similar to the one of a civilian university; a student has to sacrifice educational experience in favor of military duty. For example, if the student is ordered to leave his duty station on a contingency, the military service has priority over the EMBA. Basically, the EMBA is secondary to the officer's primary role at the duty station.

Another disadvantage of the EMBA is that it is offered in only some areas where there are command sponsorships, thus only minimum amount of URL students would be willing to enroll in the program. Moreover, the EMBA does not add value to the URL officers attached to a deployed unit or who are stationed overseas. In this perspective, if a URL officer commits to pursue a MBA degree, one would see the EMBA less attractive than the resident NPS-MBA.

THIS PAGE INTENTIONALLY LEFT BLANK

### **III. AWARENESS AND ATTITUDES OF TARGET MARKET**

In order to assess the awareness and attitudes of the Navy URL officers toward the MBA at NPS, the authors conducted a fleet survey in a fleet concentrated area in San Diego, California in March of 2004. The results of the survey provide many useful insights of how the NPS-MBA is perceived in the U.S. Naval fleet. Moreover, the survey enables the authors to generate concrete strategies and recommendations for marketing this specific MBA program to this particular target market. However, this chapter of the professional report only provides and discusses the results of the survey, while the strategies and recommendations will be discussed in subsequent chapters.

The survey's questionnaire comprised 15 questions regarding the graduate education in general and NPS-MBA in particular. A set of 65 samples from three URL sub-communities were recorded, which were far above what was required for a legitimate statistical analysis (a set of 30 samples should be a minimum for any statistical analysis yet the more the sample, the better the analysis). From observations, the authors believe that the response to the survey's questions by the three URL sub-communities were honest and accountable. The most relevant questions and responses are selected for the discussion which is divided into two parts. The first part discusses the awareness of target market toward the product, and the second part discusses the attitudes of target market toward the product. The complete survey questions and responses are provided in an appendix at the end of the report.

#### **A. AWARENESS OF TARGET MARKET TOWARD THE PRODUCT**

##### **1. Awareness of URL Community Toward NPS-MBA**

Considering the awareness of the URL community to the resident NPS-MBA, the authors discovered a quite striking result. Over 50 percent of the samples had no knowledge of the existence of the NPS-MBA before taking the survey, as the table below demonstrates.

Table 1. Awareness of URLs to the NPS-MBA [After: Ref. 15]

Awareness Level	Aware	Not Aware
No. of Response	28	36
% of Response	44	56

This is obvious that the URLs’ knowledge on graduate education opportunity is limited. While a large percentage of these URL officers spell out that they want graduate education, especially the business degree for their personal reasons, only relatively small percentage of them acknowledge the NPS-MBA’s existence. This is a very important piece of information for BPP to have, in order to take an initiative to create its brand in the Navy fleet.

## 2. Existing Distribution Channels

To have a deeper understanding of how the NPS-MBA is known in the fleet, the authors inquired of the URL officers to provide the types of communication channels they were made aware of the program. The table below illustrates the results.

Table 2. Existing Distribution Channels [After: Ref. 16]

Communication Channels	No. of Response	% of Response
Word of Mouth	20	43
Publications	8	17
NPS Website	7	15
Chain of Command	6	13
Detailers	3	6
Mentors	2	4
Others	7	15

Note: Surveyees can provide more than one response.

Based on the results in the table, it is undoubtedly that without a concrete marketing plan being implemented, word of mouth is the most powerful communication channel to get the words out, with publications as the second place that comes far behind. NPS website seems to be a fair channel as well as a chain of command in a unit. The rest of the distribution channels seem to have not communicated well in making the program

recognized in the fleet. However, a 15 percent of the “others” response is still ambiguous whether it is promising in getting the words out through these not clearly identified channels.

Another channel that has been considered very important is the detailers. This is because detailers allocate the assignments to the Navy URL officers. Detailers are the key positions that can distribute or hold back the information about graduate education opportunity to the URL community. The results from the survey show that the URL officers have not been well guided by their detailers, regarding their opportunity for graduate education. Based on the response from the survey, 97 percent of the samples revealed that their detailers had not informed them of the NPS-MBA, while only 3 percent stated the opposite. This is imperative that BPP acknowledge this in order to create concrete recommendations in the marketing plan correspondingly.

### **3. Effective Distribution Channels**

In determining the channels to distribute an NPS-MBA brand in the fleet, the authors took a further step to learn about the channel that the junior URL officers considered most effective for finding out about the program. The result shows that a largest percentage of URL officers feel that the chain of command would be the most effective channel for them to learn about the NPS-MBA. Having been URL officers ourselves, the authors agree with the response that the chain of command would be the most effective channel to learn about graduate education opportunity. This is because the intensely dynamic environment in the fleet usually does not allow the URL junior officers to have much time to think about graduate education. As natural mentors of URL junior officers, senior officers in the units can play a crucial role in directing the junior URLs toward one direction or another in every aspect of their career, including a path to graduate education.

However, this is not to say that other distribution channels from those aforementioned are less important. The results also indicate that 17 percent of the junior URL officers prefer to discuss with the detailers while 15 percent prefer to learn about the NPS-MBA via NPS website. The more details of the survey’s response, regarding the preferred distribution channels, are demonstrated in the table below.

Table 3. Effective Distribution Channels [After: Ref. 17]

Most Effective Communication Channels	No. of Response	% of Response
Chain of Command	25	39
Detailers	12	17
NPS Website	10	15
Word of Mouth	7	13
Publications	5	6
Mentors	4	4
Others	1	15

## B. ATTITUDES OF TARGET MARKET TOWARD THE PRODUCT

### 1. Value of Graduate Education

In determining how much the URL officers value graduate education, the authors acquire a very positive response from the survey. A very large percentage of the URL officers think that graduate education is very important. Only 20 percent think that a graduate education is somewhat important, whereas 3 percent don't care about it at all. The mean of the response lies between the variables 'very important' and 'extremely essential'. The table below explores the detail of the response.

Table 4. Value of Graduate Education [After: Ref. 18]

Value of Graduate Education	Not at all	Somewhat Important	Very Important	Absolutely Essential
No. of Response	2	13	26	24
% of Response	3	20	40	37

This is clear that there is an opportunity available for the BPP at NPS to market the URL community because there are potential customers out there in the fleet waiting to be informed of graduate education products available to them.

### 2. Preferred Education Funding Alternatives

In terms of graduate education funding alternatives, based on the survey, the most preferable alternative for the URL officers is a graduate education voucher. The second

choice is tuition assistance, while the resident NPS degree comes the third. The table below shows the choices of graduate education funding URL officers prefer to receive.

Table 5. Education Funding Alternatives [After: Ref. 19]

Funding Alternatives	Resident NPS	Tuition Assistance	Graduate Education Voucher	Distance Learning
No. of Response	11	22	29	3
% of Response	17	34	45	5

The fact that the resident NPS-MBA degree is not the first choice for a large number of URL officers reinforces the need for more marketing. Furthermore, that a large number of the URL officers value graduate education as very or extremely important (as discussed above) alarms the BPP leadership to take a step to attract more URL officers by making the NPS-MBA seen as the most valuable graduate degree for the URL officers.

### **3. Values of Technical Degree vs. Business Degree**

One of the valuable insights from the survey is the comparison between the two degrees – technical and business – which URL officers prefer for their personal reasons. Considering the U.S. Navy as highly technological, one might think that the core officers (URLs) would lean toward having technical degrees for their better career advancement in the Navy as well as their personal business in civilian sector. However, when considering a life after the military, one might think that any officer would absolutely like to have personal financial security; and thus, carrying a business degree would be more suitable for that matter. The results of the survey indicate that the business degree carries more value in the URL officers’ mindset, with 69 percent of the URLs selecting the business degree while only 31 percent prefer the technical degree. This shows that despite the need to possess a technical knowledge in a highly technologically advanced Navy, the business degree holds a high value for everybody.

### **4. Understanding of the Term “Defense-Focused” MBA**

Considering the name ‘MBA’ in general, one would understand what it is, or at least have heard of it due to the fact that it is a well-known degree in the corporate world.

However, the term “Defense-Focused MBA” would be ambiguous in one’s mind because it had not been introduced anywhere before. With that doubt in mind, the authors tried to find out whether the URL officers understand the term “Defense-Focused” in the title of the program. The result from the survey shows no surprise: 73 percent of the samples feel that the term “Defense-Focused” needs to be explained while 27 percent don’t need an explanation of the term. This is not to conclude that URL officers who do not need further explanation of the term, understand exactly what the term means.

### **5. Perception of the Term “Defense-Focused”**

Last but not least, to further investigate the perception of the term “Defense-Focused”, the authors asked whether the URL officers prefer the traditional MBA program or the Defense-Focused MBA program. The result from the survey indicates that 77 percent of the samples prefer to carry the traditional MBA degree rather than the Defense-Focused MBA degree. One reason for this preference might be the well-established brand of the traditional MBA in the civilian world where most of the businesses require the managers to have this particular degree. Another reason might be the misperception of the Defense-Focused MBA program as a program not providing sufficient knowledge on how to conduct a business in general firms, but defense related enterprises. Other reasons may be possible and may be left for further research. Above all, the perception of the term “Defense-Focused” would provide the insight for BPP administration to consider the plans to pursue, in order to make the term appropriately understood by the Navy URL community.

## **IV. MARKETING STRATEGY**

This chapter provides the strategies for effective marketing plan to attract the Navy URL officers to join the resident NPS-MBA program. The strategies are derived based on the situation analysis and the awareness level and the attitudes of the URL officers toward NPS-MBA. The Marketing Strategy in this particular marketing plan presents two approaches. The first approach is to use the marketing mix as a tool for reaching the needs of the target market, and attracting the customers to accept the product as a consequence. The second approach is to develop the strategies in response directly to all analyses and the survey's response provided in previous chapters. Six main strategies are provided in this direct approach.

After mastering this chapter, one should see a general guideline of marketing missions that need to be accomplished in order to achieve the goal of increasing the number of URL officers enrolling in the NPS-MBA. Then, the subsequent chapter will provide the details of the ways in which the product can reach the audience and be accepted by them. The marketing mix and the development of marketing strategies are now discussed as the following.

### **A. MARKETING MIX**

Marketing mix is a set of controllable variables that an organization in general and the BPP in particular can combine in a way to meet the needs of a target group of customers. Traditionally, the variables are represented by the Four P's: Product, Place, Promotion and Price. In marketing Defense-Focused MBA program at NPS, marketing mix would be much of assistance in recruiting URL officers into the program, with different variables being implemented as follows.

#### **1. Product**

A firm's product is a specific offering to meet the needs of a specific target market. This may involve a physical good, a service, or both. In case of the BPP, the

Defense-Focused MBA program is an education service provided to American military officers and DoD civilians as well as those of foreign nations. In order to attract the customers, BPP needs to focus on the quality of its product, the Defense-Focused MBA program, to ensure that customers (URL officers) are satisfied with the quality of education received. Furthermore, the navy establishment must also feel satisfied with the quality of education. The Navy is the organization that spends personnel resources and funding capital to the MBA program, so it is imperative that the Navy realizes a return on its investment.

BPP has ensured that the MBA program is excellent and certified by accreditation institutions. The school is accredited by the two institutions. This fact must be asserted in any promotional activity concerning the NPS-MBA. These certifications show value to the customers and demonstrate a dedication to a top quality program. Top quality faculty and staff is in place in the NPS-MBA program. Each core MBA class is taught by PhDs, senior lecturers and lecturers with no classes led by graduate students or doctorate candidates. This excellent environment ensures that students are taught by experts in their fields. The concentrated courses that are needed for sub-specialty codes are taught by civilian experts that have worked in their respective fields. These types of instructors give a hands-on perspective and up-to-date information to new ways in approaching, analyzing and solving of today's acquisition issues.

## **2. Place**

A product should generally be available when and where it is wanted. This is not possible in the case of the resident graduate education such as BPP to provide a MBA program to all URL officers who station all over the country. Prospective URL students need to temporarily move to Monterey in order to receive MBA degree. Nevertheless, Monterey may be considered as the best place to receive graduate education for many Navy URL officers due to its reputation as a tourist attraction in the central coast. In addition, its beautiful weather, world-class golf courses may be a place for short visit or long stay for many people all over the world. Moreover, the school is within driving distance of San Francisco; a city in California known for its history and scenic vistas.

Moving to a high cost of living area temporarily is difficult for some prospective students. Nevertheless, there are many types of assistance that is provided to the incoming students. There is ample housing for military members and family. Furthermore, the housing is undergoing a renovation plan that will include two story houses with a garage for qualified students. In addition there are spousal programs that facilitate the search for employment and there is childcare available.

Moreover, being in Monterey takes the URL students out of the operational environment and provides them an opportunity to focus on education with minimal distraction. All these factors of place make attending the NPS-MBA program appealing to students. It is a once in a lifetime opportunity that should be communicated as a benefit.

### **3. Promotion**

Promotion is concerned with telling the target market about the “right” product. BPP must promote the value and relevance of Defense-Focused MBA program to the URL officers. In the survey conducted in San Diego, CA many of the officers surveyed felt uncomfortable with the term “defense-focused”. We found that it may be a matter of not properly being educated in what the term means and whether it will be recognized in the civilian marketplace. Once the officers were explained what the term meant there was a level of satisfaction and appreciation. There must be efforts made to fully make clear what “defense-focused” is all about. It appears that an explanation would add value in the minds of customers and would also add credibility.

The key is to convince URLs there are real incentives for having a MBA degree, especially the one at NPS. The message should focus on how an NPS-MBA brings relevant value to them and how the degree adds to both their military and civilian careers. Not more than three messages are recommended for marketing because further message would create more confusion than attraction. Once messages are developed, distribution channels may be identified in order for the marketing group to convey messages through. The channels may be alumni, personal selling such as road-shows, research presentations, etc. The concept is to promote value of the resident MBA program at NPS as effectively as possible.

#### **4. Price**

The NPS-MBA is fully funded education, so there is no tuition that has to be paid. Although there is not a monetary value placed on the cost of students to attend NPS, students are required to commit to thirty six months more of active duty. In addition, some curriculums require a payback tour where an officer will work in an assigned billet requiring the skills that particular officer has acquired while attending the NPS-MBA program. For example a contracting student will be expected to accept orders to a hardware systems command where acquisition contracting for major weapon systems is a core competency. With this opportunity cost incurred by attending NPS-MBA program, one may argue that it is a real cost for URL officers. However, for U.S. Navy officers, virtually all of the alternate providers of MBA programs require a similar service commitment. In addition, those programs other than NPS-MBA would require additional monetary cost of attending. Consequently, attending the MBA at NPS would be more cost effective than other MBA programs. This makes the program very attractive in terms of price without any additional effort in part of the school.

#### **B. DEVELOPING MARKETING STRATEGIES**

BPP needs a marketing strategy that aligns with the overall marketing plan of NPS. Generally, in developing marketing strategy, BPP needs to define its future direction and implementation steps. Moreover, BPP needs to align the strategic direction with its long term goals along with an assessment of its internal and external environments. The strategy should concern both BPP and its environment. Henry Mintzberg states, “A basic premise of thinking about strategy concerns the inseparability of organization and environment. The organization uses strategy to deal with changing environments.”

The strategy of the marketing plan is to be developed around the strengths of the institution by exploiting the strengths and opportunities as well as mitigating the threats and weaknesses. The strategy of BPP, therefore, is designed to emphasize the uniqueness of the distinctive programs, faculty, staff, students, and alumni that make BPP special. Using the SWOT analysis and the information from the survey, the authors have arrived

at six viable strategies of BPP, which can be applied to attract the Navy URL officers into the resident NPS-MBA. The six strategies are discussed as follow:

### **1. Use Multiple Channels to Increase Awareness**

Based on the survey and the analyses, a large number of URL officers do not acknowledge the existence of the NPS-MBA. This is identified as the lack of the time slot for graduate education, no access to information, and misperception of the program as less professional and less valuable. The task of BPP is clearly to utilize all communication channels available to create awareness of the NPS-MBA in the URL community. The survey shows some channels are more preferred by the customers than others. Thus, due to limited resources at hand, BPP may put its effort on more effective channels. For instance, road shows, chain of command, detailers and the BPP website should be on the top of the list as most important communication channels to be utilized. The rest of the distribution channels should also be utilized at the same time but with appropriate efforts of BPP. The details of how to distribute the NPS-MBA brand will be discussed in the next chapter.

### **2. Create a Common Theme for the Product**

A common theme needs to be established to market the value of the NPS-MBA. The strengths and opportunities of the program should be used to create this common theme. For example, the academic excellence, great chance for promotion, fully funded education, etc., may be combined as few concept to capture the attention of the URL officers at their first glance at the program. Based on a universal concept of human psychology, the authors suggest that approximately three messages would be most effective for the target market to receive. The detail of how to create a common theme to promote the product will be further discussed in the next chapter.

### **3. Create a Unified Marketing Effort**

BPP needs an overall marketing strategy that is congruent with its strategic direction. The strategy must be continually assessed to ensure it reflects any changes in the strategic direction. Every MBA curriculum code needs to develop a marketing

concept that incorporates their strengths with BPP marketing strategy. Incorporating curriculum strengths with BPP marketing strategy will ensure that there is unity and coherence in marketing the MBA program to the URL community.

As research suggests, marketing to the Navy URL community should be a priority in each MBA curriculum. For example, these curricular may assign capable individual(s) with the responsibility for marketing efforts and evaluate its progress. Every curriculum code in the school must ensure their marketing efforts convey the BPP common theme.

In addition, BPP needs to coordinate its marketing plan with NPS to ensure that there is a consistent message between BPP and NPS as a whole. This consistency will prevent conflicting messages to the target market.

#### **4. Maintain Relationship with Key Influencers**

It is evident that one way to make any product well known in the market is to have a good relationship with key influencers. Based on the survey, the key influencers appear to be the chain of command and Bureau of Personnel (BUPERS) detailers. These key influencers are critical in providing information to URL junior officers because of their level of experience and knowledge that the junior officers rely upon. However, in reference to the chain of command, there is a minimal relationship between BPP and the Navy commands because there is no link between NPS-MBA and its graduates in general. This is because once an officer finishes his/her course work at BPP, there is minimal effort made to foster the relationship. This relationship could be developed by encouraging the growth of the alumni association and then maintaining it as a highly valuable organization to promote the NPS-MBA.

Likewise, in reference to detailers, there is minimal connection between the NPS-MBA program and BUPERS. This is because presently, BPP and BUPERS are working independently to maximize the number of the Navy URL officers attending the NPS-MBA. As a consequence, there is no incentive for the detailers to promote the NPS-MBA, and this may explain the diminishing numbers of URL officers enrolling in the program. There should clearly be an effort to foster lines of communication between BPP and BUPERS. Therefore, gaining BUPERS's upper chain of command support is crucial to providing an incentive for detailers to promote the NPS-MBA to URL officers.

## **5. Utilize the Center for Executive Education (CEE)**

The Center for Executive Education (CEE) at NPS provides customized executive-level education in revolutionary business practices to senior naval leaders and senior executive service (SES). The CEE course provides an opportunity for URL flag officers to interact with business students and faculty. This interaction could foster communication between high ranking individuals of the MBA research and the URL students who are involved in the research. Furthermore, the interaction may communicate the relevance of the NPS-MBA and its added value to the present and future Navy of the United States. The goal of the marketing plan, therefore, is to have these high ranking individuals participate in the marketing effort of the BPP. Their opinions on the work that NPS-MBA graduates perform in their research efforts and in the fleet are very powerful in increasing the program's prestige.

## **6. Establish NPS-MBA Brand**

NPS in general and BPP in particular, serve as the Navy's corporate university which is positioned to deliver state-of-the-art graduate education to the U.S. military officer corps. Every member of the Navy URL community should know the acronym 'BPP', recognize the school crest, and associate the name, 'Graduate School of Business and Public Policy,' with excellence and innovation. As a result, it is imperative that NPS-MBA brand should reach naval publications (Proceedings), career publications (Link Magazine), military websites (Navy Knowledge Online), media, and all other channels of communication to URL officers.

In addition, NPS-MBA brand should be spread to the national academic community. The academic community includes institutions and publications. Branding NPS-MBA within the national academic community is important because it creates a perception of prestige. For example, if publications dedicated to evaluating educational institutions fail to mention BPP as one of the best business schools in the country with its own uniqueness, URL Officers may be discouraged from attending the MBA program at BPP. The branding must be aggressively pursued. While BPP is a special school with a unique customer base, it shares many of the features of other business schools. BPP deserves to be measured alongside peer institutions though not fully. It is also significant

to recognize that marketing the MBA program is essential to its relevance among military stakeholders. Attracting Navy URL officers to the program is, thus, crucial because URL officers are the backbone of the Navy officer corps and their support of the MBA program will garner more influence in the Navy community.

## **V. RECOMMENDATIONS**

Before launching a successful marketing campaign to attract Navy URL officers, it is important to focus on the critical issues that are important to the BPP marketing effort, with regard to its present and future performance. The following recommendations are provided corresponding to the marketing strategies stated in a previous chapter. These recommendation guidelines can be used as a means to an end of increasing the number of the Navy URL community enrolling in NPS-MBA. Three crucial items to be focused on include:

- Messages for Product Promotion
- Promotion Channels
- Marketing Performance Evaluation

However, since marketing is an evolving process that needs cooperation and feedback from all players involved, the authors need to remind the readers that some of the recommendations may need to be revised as the strategies of the marketing plan change. This change may occur based on the change in condition of the product and in situation of the market, which are evolving phenomena. With the current setting, the discussions of the aforementioned recommendation guidelines are provided as follow.

### **A. MESSAGES FOR PRODUCT PROMOTION**

There are many strengths and opportunities of the resident MBA program at NPS, which can be used to promote the program to the Navy URL officers. However, too many messages tend not to be effective in communicating with the target market because they tend to create confusions rather than understanding. The common theme should be created instead. It has been studied that three messages would be sufficient in marketing any product to the target market. In case of marketing the Defense-Focused MBA program to the URL officers, the following three messages are recommended for use while other messages are possible.

### **1. One-Stop Shopping**

The NPS-MBA gives the student the opportunity to achieve three personal goals that would not be possible in a traditional MBA program. While at NPS, a student can earn a traditional MBA, Joint Professional Military Education (JPME), and P-codes. JPME teaches students how to work in joint military environment which is the key factor in Revolution in Military Affairs. P-codes are qualifications that the Navy identifies as professional sub-specialties. These JPME and p-codes are essential career milestones for URL career mobility. No other MBA program gives the URL students this chance.

### **2. Be a Part of Something Bigger**

Since September 11, 2001, the global environment has changed. The threats in the past were easy to ascertain. But with the threat of terrorism striking anywhere today, the world is more unstable than it has ever been. BBP can take an advantage of this moment to make URL officers feel patriotic for their involvement in defending their country. A student who earns a NPS-MBA can be a part of something bigger than oneself. One may be in a position which having executive thinking is a must. And one may be in a position that a business skill set is highly crucial. For instance, an officer may find solutions to acquisition issues that help fight the global war on terrorism.

### **3. Fully Funded Education**

With NPS-MBA, the opportunity to gain a fully funded education is obvious. The student gets his/her education while still earning regular pay and benefits. There are no out-of-pocket expenses for the student, except for books. Apart from that, the student is still able to gain time towards retirement. There is an obligation to serve 3 years in the service, but by the time officers reach this time in their career, they are already considered professional military men. Once these messages are agreed upon by BPP Administration, they may be combined as an attractive, memorable phrase or phrases, to ensure that the URL officers will highly be interested in the NPS-MBA program when they have a contact with the advertisement. The next step would be to effectively distribute these messages to the target market.

## **B. PROMOTION CHANNELS**

It is unquestionable that the most important tasks of BPP are to create awareness and promote the brand of the NPS-MBA to the implementation of a URL community. It is evident that without the marketing plan, the awareness level and the understanding of the resident NPS-MBA program is currently unfavorable. Therefore, distribution channels or communication methods are crucial matters in the marketing efforts to distribute the right messages to the very specific target market. The channels must be clearly identified and effectively utilized to attract the audience in order for them to enter the MBA program. Eleven distribution channels have been identified and are discussed as follows:

### **1. Road-Shows**

BPP faculty and students should be encouraged to take the MBA on the road accompanied by URL detailers on road-shows throughout the fleet. Bureau of Personnel (BUPERS) detailers are main players who occasionally provide Wardroom briefs on road-shows to major fleet concentration centers to educate URL officers on career planning and detailing process. Recommended concentration centers include San Diego, California; Norfolk, Virginia; and Mayport, Florida. As reflected in the results of the survey, detailers are considered a very important distribution channel to increase the awareness of the NPS-MBA. Thus, it is extremely important for BPP administration to establish a unique relationship with BUPERS in order to use them as vehicles for the distribution of the NPS-MBA brand in the fleet.

### **2. Trade-Shows**

Trade-shows can be held at BPP to expose potential students and faculty, the community, other universities and institutions of higher learning, industry and DoD to the excellence and uniqueness of this business school. Additionally, trade-shows would increase exposure to hardware commands such as NAVSEA and NAVAIR. One effective way to conduct a trade show is to make a use of Navy Campus in the fleet concentrated

areas. With that, trade-shows can be an excellent opportunity to spread the word about the NPS-MBA. The trade shows will specifically assist in:

- Introducing and demonstrating new programs of BPP
- Generating new leads (Networking)
- Meet and sell the NPS-MBA face-to-face with prospective students
- Meeting undiscovered students
- Conducting market research
- Distributing samples and insight information about NPS-MBA
- Capturing media attentions
- Understanding consumer attitudes

### **3. Career Days**

BPP should host career days in conjunction with the navy campus effort in fleet concentrated areas around the country. This should be scheduled when major battle groups are in port. The career days should highlight the three messages BPP needs to communicate, and demonstrate the relevance to the respective careers of Navy URL officers. This type of event can help boost up the levels of awareness and motivation of the URL community toward the NPS-MBA.

### **4. Brochure/Traveling Package**

Create a brochure/traveling package for MBA students, faculty and staff to take on professional and business trips. This package would include such items as DVD/CD, VHS tape, pamphlets, posters, and other memorabilia. The package should remain updated and reflect new product offerings of the BPP. This package could also be available on the Internet for easy access and customer downloads. In addition, this package may be distributed to every operational Navy command, i.e., ships, shore, or squadrons each time it is updated. With the traveling package, prospective students will be exposed to the information about NPS-MBA degree more often, and Commanding Officers (COs) will be provided with tools to discuss graduate education with their junior URL officers. The COs equipped with the package is highly beneficial as reflected in the

results of the survey, the largest percentage of URL officers feel that the chain of command would be the most effective channel for them to learn about the NPS-MBA.

## **5. BUPERS Involvement**

Currently there is minimal communication between BPP and BUPERS. As stated in the marketing strategies, BPP and the detailers do not have a team approach towards increasing the number of navy URL officers' enrolling in the NPS-MBA program. Because of the lack of a relationship with BPP, detailers have no incentive to promote the NPS-MBA. Thus, there must be a strategic relationship implemented instead of an arms length relationship, in a part of BPP. Without a tight connection between these two organizations, there is less likely that the URL officers would be able to learn about the specific programs and the real benefits such as a chance for promotion they can obtain from having MBA degree.

With that background, BPP should recognize that BUPERS is a supplier for the NPS-MBA, and it will be beneficial to form a positive relationship with them so that communication travels in both directions. BPP in general should feed information about the NPS-MBA to detailers so that they will be correctly informed and educated about the program. By the same token, detailers should provide feedback on fleet perceptions about the program to the BPP.

Due to the importance of the BUPERS as a direct vehicle for product promotion, it is recommended that a detachment of staff, faculty and/or students visit the BUPERS Headquarters in Millington, Tennessee to conduct familiarity training on the MBA and its relevance to the Navy. This training should be scheduled on a quarterly basis with its greatest effort being focused in December and January. These two months should be targeted because these are the highest negotiation periods for military orders. Since most change of station orders are effective in July, negotiations should be conducted 6 to 7 months in advance. In addition, BPP should provide detailers with a promotional traveling package to take on road-shows themselves. A strategic relationship between BPP and BUPERS would ensure that as packages are updated, they are immediately distributed to BUPERS detailers.

## **6. Internet Use**

The Internet is a great product-promotion opportunity. This is because the website may be the first means that many potential students learn about the NPS-MBA. More operational units and squadrons are gaining Internet access, and that would represent a great opportunity for URL officers to be exposed to the BPP product offerings. The website should demonstrate how an NPS-MBA adds value to the career of URL officers and why it is the best choice among fully funded graduate educational programs. Accordingly, there should be a collaborative approach to align the BPP website with the NPS website in order to inform potential students about specific issues such as housing, MWR, and points of interests. In addition, making more use of Navy community websites such as can inform officers about the advantages of an MBA. Last but not least, Quality of the website should be high as to catch Internet users' attention. For instance, the content should be intuitive and easy to use, such as Amazon.com. This is because the URL officers in general do not have much time to spend navigating websites. Also, pictures, moving images can be put in the website to make it more attractive.

## **7. Media**

The Public Affairs Office (PAO) is a key link to media involvement. It is recommended that a unified effort be established between BPP and the PAO. The ultimate goal would be to create a public relations plan that would outline BPP's goals for exposure and set up a point of contact within BPP that can feed information about the MBA program to the PAO. This plan should highlight the key strengths of the MBA and how the "Defense-Focused" is relevant to national military strategy.

BPP should exploit the capabilities that the PAO possesses in order to publish the school's successes and research work. For example, NPS, the first military institution in America that provides a Defense-Focused MBA program, should be mentioned in publications such as U.S. News & World Report, Business Week, and the Wall Street Journal. Also, Special emphasis should be placed on publications geared specifically

toward professional military officers. Examples of this type of publications are USAA's Spectrum, First Command's Magazine, NFCU's Home Port, USNA's Shipmate, and United States Navy's Perspective.

#### **8. Faculty Awareness**

Each faculty member should be encouraged to spend a few days underway or forward deployed on a ship or with a unit to promote what they do at BPP. This does two things. First, it exposes faculty to the rigors and lifestyle that the MBA students would experience. Second, it gives the fleet an opportunity to learn about the BPP at NPS and understand its commitment to improving their combat effectiveness.

#### **9. Warfare Community Awareness**

Implement a Chief of Naval Operation (CNO) Scholar Program that is similar to a Rhodes Scholar Program. This scholar program will highlight student research projects that solve major issues in the fleet. With the program, NPS-MBA may be introduced to the whole fleet and can be further promoted in terms of its value and relevance.

#### **10. Local Exposure**

Fairs and demonstrations increase social interaction with a local community and provide research opportunities for local benefit. For example, the sailing association has a great opportunity to interact with local and regional professionals at the yacht clubs. MBA project about solving the budget for Salinas High School helps the community in Salinas to recognize the BPP. This kind of interaction would undoubtedly help promote NPS in general and also BPP in particular into the local community. Any direct involvement with the local community should be published and communicated to the fleet.

#### **11. BPP Merchandising**

Merchandising is an effective channel to promote the NPS-MBA brand. For example, there are several clubs and associations within BPP. Let these organizations use

the NPS-MBA logos such as caps, t-shirts, etc., for promotion purposes. It is recommended that a partnership primarily with the Monterey Navy Exchange and generally with Navy Exchanges at large fleet concentrations be pursued. The Navy Exchanges can serve as distribution points to sell NPS-MBA merchandise. This effort would help spreading the NPS-MBA brand to the fleet at large. Today, in any Navy Exchange, there is United States Naval Academy merchandise being sold. The NPS-MBA should follow suit to instill pride in the program and to also advertise to individuals outside of the military. This type of awareness campaign would increase the value associated with the NPS-MBA and result in a greater awareness to the URL community.

## **12. BPP Alumni**

It is critical that more involvement from the alumni association be harnessed. Many of the business graduates from NPS have gone on to become leaders in the military and industry. These distinguished alumni once identified should also be a part of the marketing tools to attract the navy URL officers. By demonstrating the types of positions and work they possess, the customers can see the value of NPS-MBA degree in both military and civilian sectors. This should create more awareness in the URL community and result in URL officers wanting to enter the NPS-MBA program. These high-ranking individuals would serve as examples of the type of work that can be aspired to by obtaining an NPS-MBA. Alumni communication is vital to garnering support for the future of the BPP. A short Alumni magazine or newsletter would be a great way to keep alumni in tune with current BPP events. This can be achieved by creating an Alumni Directory that can be updated every two years. Also, there are many retired Navy members who reside in the area and can provide helpful networking opportunities.

## **13. Tag Line Creation**

BPP should consider creating the tag line that ties the NPS-MBA to the three messages mentioned above. The tag line will give name recognition of NPS-MBA to the Navy URL community, which will attract URL officers to the program. This tag line

highlights the school and the relevance to a person's military and civilian careers. For example, a good tag line would be "NPS-MBA, Your Best Defense."

### **C.     MARKETING PERFORMANCE EVALUATION**

In order to market the NPS-MBA effectively in the long run, BPP needs to evaluate whether its marketing efforts result in satisfactory outcomes: the implementation of the marketing plan actually increase the number of the Navy URL officers' enrollment in the resident NPS-MBA program. To evaluate its performance, BPP administration may periodically send out the survey to the fleet asking the target market about their understanding of and attitudes toward the MBA program. The period can be approximately six months apart. Again, to be effective, BPP needs to continue its marketing strategies so that the comparison can be made between different groups of target market who might be exposed to the program through different types of distribution channels at different time frames while the marketing plan are continuously improved and implemented. For instance, the attitude of a URL officer who is exposed to the information about the NPS-MBA program more than once should be different (in a positive way) from that of a URL officer who is exposed to the same information for the first time. In pursuing this approach, BPP administration can see the feedback from the fleet and can correct what is missing in a timely manner in order to achieve the goal of increasing URL officers' enrollment in the NPS-MBA program.

THIS PAGE INTENTIONALLY LEFT BLANK

## APPENDIX (SURVEY QUESTIONS AND RESPONSES)

1. What URL community are you a member of?

Community	Number of Responses	Response Ratio
Surface Warfare	30	46%
Submarines	18	28%
Aviation	17	26%
Special Operations	0	0%
Total	65	100%

2. Are you aware of the different graduate education opportunities available to junior URL officers?

Awareness	Number of Responses	Response Ratio
Yes	42	65%
No	23	35%
Total	65	100%

3. If you answer yes to question #2, which alternative would you prefer to fund your graduate education?

Funding Alternatives	Number of Responses	Response Ratio
Resident Naval postgraduate School	11	17%
Tuition assistance	22	34%
Graduate Education Voucher	29	45%
Distance Learning	3	5%
Total	65	100%

4. If you picked any answer besides resident Naval postgraduate School in question #3, please explain your reason.

Reasons	Number of Responses	Response Ratio
Not aware of NPS	2	3%
Value civilian education higher than NPS	13	26%
Don't like the NPS military commitment	26	23%
Others, please specify	24	48%
Total	65	100%

5. How much do you value graduate education?

<b>Value</b>	<b>Number of Responses</b>	<b>Response Ratio</b>
Not at all	2	3%
Somewhat important	13	20%
Very important	26	40%
Absolutely essential	24	37%
Total	65	100%

6. Which degree would be more beneficial to your Naval career?

<b>Type of Degree</b>	<b>Number of Responses</b>	<b>Response Ratio</b>
Business	33	51%
Technical	32	49%
TOTAL	65	100%

7. Which type of degree would you prefer for personal reasons?

<b>Type of Degree</b>	<b>Number of Responses</b>	<b>Response Ratio</b>
Business	45	69%
Technical	20	31%
TOTAL	65	100%

8. How much do you value a MBA?

<b>Value</b>	<b>Number of Responses</b>	<b>Response Ratio</b>
Not at all	10	15%
Somewhat important	18	28%
Very important	27	42%
Absolutely essential	10	15%
TOTAL	65	100%

9. Are you aware that the naval postgraduate School offers a resident MBA?

<b>Awareness</b>	<b>Number of Responses</b>	<b>Response Ratio</b>
Yes	28	44%
No	36	56%
Total	64	100%

10. If you are aware of the Naval Postgraduate School MBA, how were you made aware of the program? You may pick more than one answer.

<b>Distribution Channels</b>	<b>Number of Responses</b>	<b>Response Ratio</b>
Publications	8	17%
Word of mouth	20	43%
Mentors	2	4%
Chain of Command	6	13%
NPS Website	7	15%
Detailers	3	6%
Other	1	2%
Others, Please specify	6	13%

11. Has your detailer discussed with you about the MBA program at the Naval Postgraduate School?

<b>Discussion with Detailers</b>	<b>Number of Responses</b>	<b>Response Ratio</b>
Yes	2	3%
No	63	97%
Total	65	100%

12. What do you recommend as the most effective way for junior officers to learn about the MBA program? Please rank in order.

<b>Effective Distribution Channels</b>	<b>Number of Responses</b>	<b>Response Ratio</b>
Publications	5	8%
Word of mouth	7	11%
Mentors	4	6%
Chain of Command	25	39%
NPS Website	10	16%
Detailers	12	19%
Others, Please specify	1	2%
Total	65	100%

13. Naval Postgraduate School offers a “defense focused” MBA. What type of impression does that give you.

<b>Impression</b>	<b>Number of Responses</b>	<b>Response Ratio</b>
Positive	24	38%
Negative	25	40%
Others, Please specify	14	22%
Total	63	100%

14. Do you feel that the term “defense focused” needs to be explained further?

<b>Understanding of the Term “Defense-Focused”</b>	<b>Number of Responses</b>	<b>Response Ratio</b>
Yes	47	73%
No	17	27%
Total	64	100%

15. The Naval Postgraduate School MBA offers a core curriculum of a “traditional” MBA, but it gives further instruction on subjects that are defense industry related. Which degree program would you prefer?

<b>Preferred Program</b>	<b>Number of Responses</b>	<b>Response Ratio</b>
Defense Focused MBA	15	23%
Traditional MBA	49	77%
Total	64	100%

## LIST OF REFERENCES

1. Registrar website. <http://www.nps.navy.mil/ofcinst/sob/sob.htm> January 2004.
2. Registrar website. <http://www.nps.navy.mil/gsbpp/curriculum> January 2004.
3. Hicks, Greg. Soundoff “Naval Postgraduate School offers Defense-Focused degree”.  
<http://www.ftmeade.army.mil/SoundOff/archives/SO2002/May02/html/Education>
4. Hicks, Greg. Soundoff “Naval Postgraduate School offers Defense-Focused degree”.  
<http://www.ftmeade.army.mil/SoundOff/archives/SO2002/May02/html/Education>
5. BPP website. <http://nps.navy.mil/gsbpp/overview.htm> January 2004.
6. Registrar website. [www.nps.navy.mil/ofcinst/sob/sob.htm](http://www.nps.navy.mil/ofcinst/sob/sob.htm). January 2004.
7. Mack, William P., Thomas D. Paulsen. The Naval Officer’s Guide, 9<sup>th</sup> Edition, Naval Institute Press, Annapolis, MD. p. 376-378. 1988.
8. BPP website. <http://nps.navy.mil/gsbpp/overview.htm> January 2004.
9. BPP website. <http://nps.navy.mil/gsbpp/overview.htm> January 2004.
10. Perspective Magazine. January-February 1997.
11. Goodwin Darlene Naval Education and Training Command Public Affairs  
[http://www.news.navy.mil/search/display.asp?story\\_id=10997](http://www.news.navy.mil/search/display.asp?story_id=10997).
12. Navy Campus website. <https://www.navycollege.navy.mil/ta1.html> March 2004.
13. Troy State website. <http://www.troyst.edu/universitycollege/regions.html> April 2004.
14. Executive MBA website. <http://www.emba.nps.navy.mil> April 2004.
15. Appendix (Question #9).
16. Appendix (Question #10).
17. Appendix (Question #12)
18. Appendix (Question #5).
19. Appendix (Question #3).

THIS PAGE INTENTIONALLY LEFT BLANK

## INITIAL DISTRIBUTION LIST

1. Defense Technical Information Center  
Ft. Belvoir, Virginia
2. Dudley Knox Library  
Naval Postgraduate School  
Monterey, California
3. Office of The Naval Attaché  
Royal Thai Embassy  
Washington, D.C.
4. Professor Becky Jones  
Graduate School of Business and Public Policy  
Naval Postgraduate School  
Monterey, California
5. Dr. Doug Moses  
Graduate School of Business and Public Policy  
Naval Postgraduate School  
Monterey, California