



Calhoun: The NPS Institutional Archive
DSpace Repository

NPS Scholarship

Theses

1994-06

Experimental investigation into the dynamic response of two DOF tuned deck simulator for shock qualification of shipboard systems

Flynn, Timothy V.

Monterey, California. Naval Postgraduate School

<https://hdl.handle.net/10945/30854>

This publication is a work of the U.S. Government as defined in Title 17, United States Code, Section 101. Copyright protection is not available for this work in the United States.

Downloaded from NPS Archive: Calhoun



Calhoun is the Naval Postgraduate School's public access digital repository for research materials and institutional publications created by the NPS community. Calhoun is named for Professor of Mathematics Guy K. Calhoun, NPS's first appointed -- and published -- scholarly author.

Dudley Knox Library / Naval Postgraduate School
411 Dyer Road / 1 University Circle
Monterey, California USA 93943

<http://www.nps.edu/library>

NAVAL POSTGRADUATE SCHOOL
Monterey, California



THESIS

Experimental Investigation into the Dynamic Response of Two
DOF Tuned Deck Simulator for Shock Qualification of Shipboard
Systems

by

Timothy V. Flynn III

June 1994

Thesis Advisor:

Y. S. Shin

Thesis
F5276

Approved for public release; distribution is unlimited.

DUDLEY KNOX LIBRARY
NAVAL POSTGRADUATE SCHOOL
MONTEREY CA 93943-5101

REPORT DOCUMENTATION PAGE

Form Approved OMB No. 0704-0188

Public reporting burden for this collection of information is estimated to average 1 hour per response, including the time for reviewing instruction, searching existing data sources, gathering and maintaining the data needed, and completing and reviewing the collection of information. Send comments regarding this burden estimate or any other aspect of this collection of information, including suggestions for reducing this burden, to Washington headquarters Services, Directorate for Information Operations and Reports, 1215 Jefferson Davis Highway, Suite 1204, Arlington, VA 22202-4302, and to the Office of Management and Budget, Paperwork Reduction Project (0704-0188) Washington DC 20503.

AGENCY USE ONLY (Leave blank)		2. REPORT DATE June 1994	3. REPORT TYPE AND DATES COVERED Master's Thesis	
4. TITLE AND SUBTITLE EXPERIMENTAL INVESTIGATION INTO THE DYNAMIC RESPONSE OF TWO DOF TUNED DECK SIMULATOR FOR SHOCK QUALIFICATION OF SHIPBOARD SYSTEMS			5. FUNDING NUMBERS	
6. AUTHOR(S) Timothy V. Flynn III				
7. PERFORMING ORGANIZATION NAME(S) AND ADDRESS(ES) Naval Postgraduate School Monterey CA 93943-5000			8. PERFORMING ORGANIZATION REPORT NUMBER:	
9. SPONSORING/MONITORING AGENCY NAME(S) AND ADDRESS(ES) Naval Sea Systems Command Washington, D.C. 20362-5105			10. SPONSORING/MONITORING AGENCY REPORT NUMBER:	
11. SUPPLEMENTARY NOTES The views expressed in this thesis are those of the author and do not reflect the official policy or position of the Department of Defense or the U.S. Government.				
12a. DISTRIBUTION/AVAILABILITY STATEMENT Approved for public release; distribution is unlimited.			12b. DISTRIBUTION CODE	
13. ABSTRACT (maximum 200 words) The explosive shock created by the underwater explosion of a mine or torpedo in close proximity to a surface ship can severely threaten the combat capability and survivability of the ship. MIL-S-901D specifies the shock test procedures and acceptance criteria for all shipboard systems that must resist high impact mechanical shock. While the U.S. Navy's Mediumweight Shock Machine with its standard equipment mounting fixture can subject a combat systems component to more severe shock excitations than experienced in actual ship shock trials, it cannot simulate the lower frequency excitations typically transmitted through a ship's superstructure during shock trials that expose equipment to catastrophic resonant vibration. This study is an experimental investigation into the dynamic response of the recently built Two Degree-of-Freedom (2DOF) Tuned Deck Simulator (TDS) for the Mediumweight Shock Machine (MWSM) to evaluate its potential role in the pre-acceptance shock qualification of new shipboard combat systems equipment. Upon completion of final characterization testing, the 2DOF-TDS could be integrated into the mediumweight shock qualification procedures of MIL-S-901D. This improvement could significantly enhance the capacity of a warship to absorb damage and still maintain its mission integrity.				
14. SUBJECT TERMS U.S. NAVY MEDIUMWEIGHT SHOCK MACHINE, TWO DOF TUNED DECK SIMULATOR, EQUIPMENT MECHANICAL SHOCK QUALIFICATION.			15. NUMBER OF PAGES: 94	
			16. PRICE CODE	
17. SECURITY CLASSIFICATION OF REPORT Unclassified	18. SECURITY CLASSIFICATION OF THIS PAGE Unclassified	19. SECURITY CLASSIFICATION OF ABSTRACT Unclassified	20. LIMITATION OF ABSTRACT UL	

NSN 7540-01-280-5500

Standard Form 298 (Rev. 2-89)

Prescribed by ANSI Std. Z39-18

Approved for public release; distribution is unlimited.

Experimental Investigation into the Dynamic Response of Two DOF Tuned Deck Simulator for Shock Qualification of Shipboard Systems

by

Timothy V. Flynn III
Lieutenant Commander, United States Navy
B.S. United States Naval Academy, 1979
M.S. Naval Postgraduate School, 1986

Submitted in partial fulfillment
of the requirements for the degree of

MASTER OF SCIENCE IN MECHANICAL ENGINEERING

from the

NAVAL POSTGRADUATE SCHOOL
June 1994

Author:

Timothy V. Flynn III

Approved by:

Yoong S. Shin, Thesis Advisor

Matthew D. Kelleher, Chairman
Department of Mechanical Engineering

ABSTRACT

The explosive shock created by the underwater explosion of a mine or torpedo in close proximity to a surface ship can severely threaten the combat capability and survivability of the ship. MIL-S-901D specifies the shock test procedures and acceptance criteria for all shipboard systems that must resist high impact mechanical shock. While the U.S. Navy's Mediumweight Shock Machine with its standard equipment mounting fixture can subject a combat systems component to more severe shock excitations than experienced in actual ship shock trials, it cannot simulate the lower frequency excitations typically transmitted through a ship's superstructure during shock trials that expose equipment to catastrophic resonant vibration. This study is an experimental investigation into the dynamic response of the recently built Two Degree-of-Freedom (2DOF) Tuned Deck Simulator (TDS) for the Mediumweight Shock Machine (MWSM) to evaluate its potential role in the pre-acceptance shock qualification of new shipboard combat systems equipment. Upon completion of final characterization testing, the 2DOF-TDS could be integrated into the mediumweight shock qualification procedures of MIL-S-901D. This improvement could significantly enhance the capacity of a warship to absorb damage and still maintain its mission integrity.

TABLE OF CONTENTS

I. INTRODUCTION	1
II. BACKGROUND	6
A. DDG-51 PRE-SHOCK TRIAL SPECTRA VERSUS MWSM SPECTRA	6
1. Transient Shock Analysis of DDG-51 Class Forward Deckhouse	7
2. Need for an Improved MWSM Fixture	7
B. DESIGN AND CONSTRUCTION OF THE 2DOF TUNED DECK SIMULATOR	9
1. Initial Design Phase	9
2. Model Refinement Phase	10
3. Final Design Phase and Stress Analysis	10
4. Tunability Features of the 2DOF Tuned Deck Simulator	12
C. DDG-51 MODAL TESTING AND TARGET RESONANT FREQUENCIES FOR THE 2DOF TUNED DECK SIMULATOR	12
III. CHARACTERIZATION OF THE 2DOF TUNED DECK SIMULATOR	15
A. DESCRIPTION OF 2DOF TUNED DECK SIMULATOR TESTING	15
1. Test Schedule	16
2. Data Collection and Processing	16
B. PHASE II DATA REDUCTION	17
1. Absolute Acceleration Shock Spectra Determination Using MATLAB [®]	18
2. Resultant Shock Spectra from Phase II Tests	21
C. STANDARD FIXTURE SPECTRA VERSUS 2DOF TUNED DECK SIMULATOR SPECTRA	22
1. Comparison of Shock Spectra with Test Weight of 500 Pounds	22
2. Comparison of Shock Spectra with Test Weight of 1000 Pounds	23
3. Summary of Observations	23
4. Discussion of Results	24
IV. SHOCK QUALIFICATION AND THE 2DOF TUNED DECK SIMULATOR	26
A. PHASE II ACCELERATION SHOCK SPECTRAL PEAKS	26
1. Effects of Averaging Absolute Acceleration Shock Spectra	27
2. "Modeled" Average Absolute Acceleration Shock Spectra	28
3. Determining System Natural Frequencies Using MATHCAD [®]	29
B. FREQUENCIES OF SHOCK SPECTRAL PEAKS	29
1. Methods Utilized	29
2. Comparison Between Methods	31
C. 2DOF TUNED DECK SIMULATOR COMPATIBILITY WITH MIL-S-901D32	32
1. Basic Requirements	32
2. Maximum Bending Stress Versus Yield Strength	33

3. Compatibility Achieved	34
V. CONCLUSION	36
A. PROJECTED UTILIZATION OF THE 2DOF TUNED DECK SIMULATOR	36
B. PROPOSED ADDENDUM TO MIL-S-901D	37
1. Proposed Test Schedules	37
2. Need for Expanded Coverage	37
3. Environmental Issues	38
C. RECOMMENDATIONS	39
APPENDIX A: FIGURES	41
APPENDIX B: TABLES	64
Appendix B 1: Phase II Test Schedule	64
Appendix B 2: Results of Test #1	65
Appendix B 3: Results of Test #2	66
Appendix B 4: Results of Test #3	67
Appendix B 5: Results of Test #4	68
Appendix B 6: Results of Test #5	69
Appendix B 7: Results of Test #6	70
Appendix B 8: Proposed Addendum to MIL-S-901D	71
APPENDIX C: MATLAB® PROGRAMS AND MATHCAD® WORKSHEET	73
Appendix C.1: Model APPC1.M	73
Appendix C.2: Model APPC2.M	75
Appendix C.3: MATHCAD® Worksheet: System Natural Frequencies	81
LIST OF REFERENCES	83
INITIAL DISTRIBUTION LIST	84

LIST OF TABLES

TABLE 1. PHASE II TEST SCHEDULE FOR 2DOF-TDS ON MWSM	64
TABLE 2. TEST 1: INITIAL CONDITIONS	65
TABLE 3. TEST 1: ABSOLUTE ACCELERATION SHOCK SPECTRAL PEAK FREQUENCIES	65
TABLE 4. TEST 2: INITIAL CONDITIONS	66
TABLE 5. TEST 2: ABSOLUTE ACCELERATION SHOCK SPECTRAL PEAK FREQUENCIES	66
TABLE 6. TEST 3: INITIAL CONDITIONS	67
TABLE 7. TEST 3: ABSOLUTE ACCELERATION SHOCK SPECTRAL PEAK FREQUENCIES	67
TABLE 8. TEST 4: INITIAL CONDITIONS	68
TABLE 9. TEST 4: ABSOLUTE ACCELERATION SHOCK SPECTRAL PEAK FREQUENCIES	68
TABLE 10. TEST 5: INITIAL CONDITIONS	69
TABLE 11. TEST 5: ABSOLUTE ACCELERATION SHOCK SPECTRAL PEAK FREQUENCIES	69
TABLE 12. TEST 6: INITIAL CONDITIONS	70
TABLE 13. TEST 6: ABSOLUTE ACCELERATION SHOCK SPECTRAL PEAK FREQUENCIES	70
TABLE 14. FOR INITIAL SPECTRAL PEAK BETWEEN 45 - 55 HZ AND SECOND PEAK BETWEEN 90 -100 HZ	71
TABLE 15. FOR INITIAL SPECTRAL PEAK BETWEEN 55 - 65 HZ AND SECOND PEAK BETWEEN 90 -100 HZ	71

LIST OF FIGURES

Figure 1. The Navy High-Impact Shock Machine for Mediumweight (MWSM). The Dotted Line Shows Hammer Path (Courtesy of Clements).....	41
Figure 2. DDG-51 Pretrial Predicted Acceleration Time History Versus MWSM with Standard Fixture Actual Acceleration Time History.....	42
Figure 3. DDG-51 Pretrial Predicted Absolute Acceleration Shock Spectra Versus MWSM with Standard Fixture Actual Absolute Acceleration Shock Spectra.....	43
Figure 4. Model of 2DOF Tuned Deck Simulator as Two Mass-Spring-Damper Systems Coupled Together (Courtesy of Cox).....	44
Figure 5. 1/4 Scale Model of the 2DOF Tuned Deck Simulator for the MWSM. (Courtesy of Cox).....	45
Figure 6. Bill of Material for the 2DOF Tuned Deck Simulator and Schematic Drawing (Courtesy of Naval Surface Warfare Center, Silver Springs, Md.).....	46
Figure 7. Photograph of 2DOF Tuned Deck Simulator with Aluminum Mounting Plate and 500 Pound Test Load atop the MWSM Anvil Table.....	47
Figure 8. Block Diagram of Test Phase II Shock Data Acquisition and Processing Instrumentation.....	48
Figure 9. Acceleration Time History (Channel 5) and Absolute Acceleration Shock Spectra for Test 4 Blow 7.....	49
Figure 10. Absolute Acceleration Shock Spectra for Test 1 (10 Drops).....	50
Figure 11. Absolute Acceleration Shock Spectra for Test 2 (8 Drops).....	51
Figure 12. Absolute Acceleration Shock Spectra for Test 3 (9 Drops).....	52
Figure 13. Absolute Acceleration Shock Spectra for Test 4 (9 Drops).....	53
Figure 14. Absolute Acceleration Shock Spectra for Test 5 (10 Drops).....	54
Figure 15. Absolute Acceleration Shock Spectra for Test 6 (9 Drops).....	55
Figure 16. Standard Fixture Versus 2DOF Tuned Deck Simulator (3/4 Configuration).....	56
Figure 17. Standard Fixture Versus 2DOF Tuned Deck Simulator (2/4 Configuration).....	57
Figure 18. Average Absolute Acceleration Shock Spectra Versus “Modeled” Average Acceleration Shock Spectra for Test 1.....	58
Figure 19. Average Absolute Acceleration Shock Spectra Versus “Modeled” Average Acceleration Shock Spectra for Test 2.....	59
Figure 20. Average Absolute Acceleration Shock Spectra Versus “Modeled” Average Acceleration Shock Spectra for Test 3.....	60
Figure 21. Average Absolute Acceleration Shock Spectra Versus “Modeled” Average Acceleration Shock Spectra for Test 4.....	61
Figure 22. Average Absolute Acceleration Shock Spectra Versus “Modeled” Average Acceleration Shock Spectra for Test 5.....	62
Figure 23. Average Absolute Acceleration Shock Spectra Versus “Modeled” Average Acceleration Shock Spectra for Test 6.....	63

ACKNOWLEDGEMENTS

I would like to express my sincerest appreciation to Professor Young S. Shin for his inspirational leadership and technical guidance throughout this endeavor. His wisdom, consummate professionalism and untiring support have significantly enhanced my education at the Naval Postgraduate School.

Additionally, I extend my gratitude to Mr. Mark McLean of the Naval Sea Systems Command for sponsoring this research and to Lieutenant David Cox, USN, for answering all of my questions about his brilliant design during the last six months. My thanks also go out to Mr. Gerald Messina and Mr. Bill Briggs of the Naval Undersea Warfare Center, Newport, R.I. who conducted over 95 Mediumweight Shock Machine tests in support of my research.

Above all, I wish to express my heartfelt gratitude to Nicole Flynn for her cheerful encouragement, steadfast support and total understanding as I “deployed” to the Vibrations Lab for the duration of this project.

I. INTRODUCTION

Survivability is defined as the capacity of a ship to absorb damage and maintain mission integrity. In September 1988, the Chief of Naval Operations issued a comprehensive policy directive to incorporate survivability features into new surface ship designs, ship overhauls, and new combat systems. This directive ranked survivability equal in significance to such fundamental design requirements as maneuverability and combat systems capability. The minimum baseline of ship survivability includes: armor, shielding and signature reduction, and the shock hardening of vital systems. The directive tasked the Commander, Naval Sea Systems Command, with establishing and validating survivability performance and test standards matched to actual and anticipated threats. (OPNAV, 1988, pp. 2-5)

One major threat to surface ships is the explosive shock created by the underwater explosion of a mine or torpedo in close proximity to the ship. The U.S. Navy's shock hardening policies and procedures are primarily concerned with ensuring the operability of mission essential systems. Shock hardening is required for all ships designated as capable of operating in the combat shock environment, including: surface combatants, aircraft carriers, amphibious ships, mine warfare ships, and others designated to operate inside combat zones. The Naval Sea Systems Command (NAVSEA) requires that all new construction ships be shock hardened and that all overhaul contracts and major combat system design upgrades include appropriate shock qualification requirements. (NAVSEA, 1989, p. 4)

The U.S. Navy's shock qualification requirements are contained in Military Specifications, MIL-S-901D, "Shock Tests, High Impact; Shipboard Machinery, Equipment and Systems, Requirements for," which specifies the shock test procedures and acceptance criteria for all grades and classes of shipboard systems that must resist high impact mechanical shock. The three methods of shock testing are:

- Lightweight Shock Machine Test for equipment and mounting with a combined weight less than 550 pounds using the Lightweight Shock Machine (LWSM)
- Mediumweight Shock Machine Test for equipment and mounting with a combined weight less than 7400 pounds using the MWSM
- Heavyweight Shock Test for equipment weights exceeding MWSM capacity

The Lightweight Test requires the LWSM which consists of a welded steel framework equipped with a rotating anvil plate and two 400 pound hammers that can be configured for shock testing equipment along three orthogonal axes without remounting (Clements, 1972, p. 32). The Heavyweight Test requires a floating shock platform and submerged explosive charges and is recommended in cases where the simulation of deck-mounted conditions is desired. (MIL-S-901D, 1989, pp. 12-16)

This research is focused on the Mediumweight Shock Machine (MWSM) and the new Two Degree-of-Freedom Tuned Deck Simulator (2DOF-TDS) upon which a test item would be base-mounted for shock loadings in the vertical direction. Before proposing a future role for the 2DOF-TDS in the shock qualification of vital combat systems, a description of current mediumweight shock qualification is necessary.

A schematic drawing of the MWSM is provided in Figure 1. The MWSM is a hammer-anvil table apparatus originally designed in 1942. After release from a specified height, the 3000 pound hammer swings through an arc of up to 270 degrees and strikes the 4500 pound anvil table from below, imparting an upward acceleration to both the table and the test item mounted on the table. The anvil table vertical travel distance after impact is limited to either 3.0 inches (due to 12 foundation bolts which act as mechanical stops), or 1.5 inches (if installed pneumatic jacks are used to raise the anvil table prior to impact). (Clements, 1972, p. 69)

All items subject to mediumweight shock testing receive a minimum of six hammer blows which are applied in three groups of two blows each. MIL-S-901D specifies the height of the hammer drop and the anvil table travel distance for each group. One blow of each group is conducted with the test item in its normal attitude to simulate shipboard shock loadings in the vertical direction. The second blow of each group is conducted with the test item mounted in the inclined position to simulate shipboard shock loadings in the athwartship direction. Test items that are essential to the safety and combat capability of the ship must be operated in their normal operating modes atop the MWSM during the first and third groups of blows. Alternate modes of operation (i.e., "standby" mode), are tested during the second group of blows. (MIL-S-901D, 1989, p. 19)

According to MIL-S-901D, base-mounted items intended for horizontal surfaces aboard ship are normally mounted on the anvil table by means of a standard fixture, consisting of a specified number of support channels atop two shipbuilding rails attached to the anvil table, for shock loadings in the vertical direction. Figure 13 of MIL-S-901D

illustrates typical standard fixture arrangements and provides a table which enables the user to determine the number of supporting floor and ceiling building channels required for a given equipment weight and size (MIL-S-901D, 1989, pp.67-69). A standard inclined fixture for shock loading in the athwartship direction is used to incline the test item in the same direction that the item would incline aboard ship if the ship were to roll 30 degrees.

All standard mounting fixtures are intended to represent hull-mounted conditions that exist at main structural members of the ship (primarily below the main deck). For deck-mounted conditions, MIL-S-901D with some exceptions limits the use of standard mounting fixtures to equipment installed aboard ship without resilient mountings (i.e., Class I equipment), primarily located on the main deck and above, but also on decks and non-structural bulkheads below the main deck. When simulating deck-mounted conditions, MIL-S-901D stipulates that the fundamental frequency (with the equipment installed on the fixture) shall not be lower than 25 Hz in each principal shock direction. (MIL-S-901D, 1989, pp. 2-12)

The primary issue is whether or not the MWSM and standard fixture can realistically simulate a ship's actual response to an underwater explosion for the pre-acceptance shock testing of new shipboard combat systems, particularly equipment designated for deck-mounting in a ship's superstructure. While the MWSM and standard fixture generate a more severe shock excitation than experienced in actual ship shock trials, the test item is not subjected to the lower frequency excitations typically transmitted through a ship's superstructure during shock trials (Cox, 1993, pp. 7-8). If the ship's structure excites the combat systems equipment at lower frequencies than those generated by the MWSM and

standard fixture, an actual underwater explosion in close proximity to the ship could expose the equipment to catastrophic resonant vibration not previously simulated during pre-installation shock qualification tests. A 1992 study revealed that the short-duration, high-impulse, high-frequency excitation waveform generated by the MWSM and transmitted to the test item via the standard fixture significantly differs from actual waveforms observed at various equipment locations aboard ship during shock trials (Corbell, 1992, p. 4). For more accurate mediumweight shock testing of vital combat systems equipment, Corbell proposed that the standard fixture be replaced by a two degree-of-freedom mounting fixture pre-tuned to simulate the dominant shock characteristics derived in the ship class pre-shock trial analyses.

The 2DOF-TDS for the MWSM was designed by Cox, and a prototype was built in 1993. This study is an experimental investigation into the dynamic response of the 2DOF Tuned Deck Simulator to evaluate its potential role in mediumweight shock qualification. Chapter II provides background information on the design and construction of the 2DOF-TDS. The characterization of the 2DOF-TDS on the MWSM through actual shock testing is presented in Chapter III. Chapter IV addresses the possibility of incorporating the 2DOF-TDS into mediumweight shock qualification procedures as an addendum to MIL-S-901D. The conclusion and recommendations toward addendum validation are presented in Chapter V.

II. BACKGROUND

Foremost among the U.S. Navy's surface ship survivability priorities is the shock hardening of mission essential equipment. Given the increasing budgetary constraints facing the U.S. Navy today, making incremental improvements to the simulation accuracy of the six government-owned MWSM's may be more feasible than developing a replacement for the MWSM. Before exploring the design and construction of the 2DOF Tuned Deck Simulator, a comparison of the DDG-51 Class pre-shock trial spectra with that generated by the MWSM and standard fixture is in order.

A. DDG-51 PRE-SHOCK TRIAL SPECTRA VERSUS MWSM SPECTRA

In underwater shock analysis, the shock spectrum is defined as the maximum absolute response of an undamped single DOF system subjected to a base acceleration initiated by contact with a shock wave. The shock spectra encompass the undamped single DOF system's absolute maximum response envelope over a wide range of system natural frequencies resulting from a specific excitation. For a given excitation, the resultant shock spectra reveal the peak resonance responses experienced by the system. If the complex combination of natural frequencies in a ship's structure following an underwater explosion further excites the natural frequencies of components inside vital combat systems equipment, significant equipment damage and a drastic reduction in the ship's combat capability may result. In order to simulate this shipboard excitation on the

MWSM, it is not necessary to reproduce the actual waveform, only its frequency components at their respective acceleration amplitudes (Cox, 1993, p. 9).

1. Transient Shock Analysis of DDG-51 Class Forward Deckhouse

In 1992, Costanzo and Murray of the David Taylor Research Center Underwater Explosion Research Division (DTRC/UERD), completed a transient shock analysis of the DDG-51 Class forward deckhouse and mast in preparation for the shock trial of DDG-53 in 1994. Their finite element model of the forward deckhouse included three lumped, rigid masses representing significant combat systems components, ranging in weight from 325 to 4600 pounds, all located on the ship's 0-3 level. Applying the maximum shock trial excitations obtained during previous CG-47 Class cruiser shock trials to major support bulkheads of the DDG-51 forward deckhouse model, Costanzo and Murray computed the dynamic responses, including the predicted vertical acceleration waveforms and the resultant shock spectra, at the approximate locations of the three combat systems components. (Corbell, 1992, pp. 11-15)

Although all three components were located on the 0-3 level of the DDG-51 Class forward deckhouse, the predicted acceleration waveforms and their respective shock spectra were dramatically different. Corbell compared the Costanzo and Murray finite element model's acceleration waveform with that generated by Clement's MWSM model and concluded that the MWSM with standard fixture could not reproduce the "characteristic shock phenomena observed in the field" (Corbell, 1992, pp. 15-16).

2. Need for an Improved MWSM Fixture

To substantiate Corbell's conclusion, a comparison between Costanzo and Murray's predicted acceleration time history for one of their three tested components, the

SPY-1D Radar Beam Programmer weighing 1000 pounds, and actual MWSM (with standard fixture) acceleration data obtained by the Naval Undersea Warfare Center (NUWC), New London, in a June 1993 test series to characterize the MWSM was performed (depicted in Figure 2). The NUWC test data chosen for this comparison involved a 1000 pound test weight supported by a 300 pound aluminum plate atop the standard fixture (Messina, 1993). Although the combined weight on the MWSM exceeded the weight of the beam programmer by 300 pounds, the difference in the respective acceleration time histories is significant.

More significant than this waveform comparison in the time domain is a comparison of the shock wave characteristics displayed in the frequency domain as shock spectra. The respective absolute acceleration shock spectra are depicted in Figure 3. Although some correlation of the respective shock spectral peak locations exists, the acceleration amplitudes in the MWSM's shock spectra are significantly higher than those of the beam programmer. While MIL-S-901D does not require that any particular waveform or spectra be reproduced during shock testing, this comparison clearly signifies the need for an improved MWSM fixture that can more accurately simulate shock phenomena observed in the field for the pre-acceptance shock qualification of new combat systems equipment.

From the DTRC/UERD DDG-51 Class pre-shock trial analysis, Corbell observed that the vertical orientation shock spectra of both light and medium weight equipment revealed two common, well-defined dominant peaks at 60 Hz and 155 Hz, respectively. Corbell mathematically modeled a 2DOF uniaxial mounting fixture that was

tuned to achieve 60 Hz and 155 Hz as its coupled response frequencies and concluded that the design and construction of such a fixture was warranted. (Corbell, 1992, pp 51-73)

B. DESIGN AND CONSTRUCTION OF THE 2DOF TUNED DECK SIMULATOR

1. Initial Design Phase

Following Corbell's lead, Cox set out to design a tunable 2DOF Deck Simulator for the MWSM that would excite combat systems equipment with most of the energy concentrated at two dominant resonant frequencies pre-selected from actual ship shock trial spectral analysis or from modal analysis at the equipment's designated location aboard ship. Initially using Corbell's target frequencies of 60 Hz and 155 Hz for shock spectral peaks, Cox modeled the 2DOF Tuned Deck Simulator as two mass-spring-damper systems coupled together as depicted in Figure 4. The mass "M1" represented the combined masses of the test object and associated mounting hardware. The mass "M2" represented the combined masses of the intermediate structure and associated hardware. The characteristic stiffness and damping properties of the two tiers were designated by "K" and "C" respectively. Cox later included the effective spring mass of his design's upper spring beams into M1 and that of both upper and lower spring beams into M2. Cox also modeled the anvil acceleration associated with a hammer release height of one foot as a half-sine wave vertical acceleration impulse of 1 millisecond duration as done previously by Clements and Corbell. (Cox, 1993, p. 16)

2. Model Refinement Phase

After deriving the model's coupled differential equations of motion in matrix form with coordinates relative to the motion of the anvil table, Cox calculated the first two natural frequencies. Defining f_1 and f_2 as the "uncoupled" tier natural frequencies, and f_{n1} and f_{n2} as the "coupled" system natural frequencies, Cox derived equations relating the system's coupled and uncoupled natural frequencies. Choosing 60 Hz and 155 Hz as his desired system natural frequencies, Cox iteratively solved these equations for the required uncoupled natural frequencies. For example, assuming a mass ratio (i.e., M_1/M_2), of 1.0 and an uncoupled lower tier natural frequency (f_2) of 100 Hz, an upper tier natural frequency (f_1) of 94 Hz would be required to provide system natural frequencies (f_{n1} and f_{n2}) of 60 Hz and 155 Hz. (Cox, 1993, pp. 18-20)

Cox then uncoupled the model's equations of motion, assumed values of damping between 0.03 and 0.05, and – using a MATLAB® simulation algorithm – obtained system displacement, velocity and acceleration responses to the half-sine wave impulse. Cox used this algorithm to determine the displacements of each tier relative to the anvil table for various MWSM hammer heights and weights atop the 2DOF-TDS. From this data, the maximum dynamic relative displacement within the 2DOF-TDS was obtained for a static stress analysis of the components to aid in their material selection. (Cox, 1993, pp. 23-28)

3. Final Design Phase and Stress Analysis

With the objective of defining a structure that would both provide the desired response without plastic yielding or cracking during shock tests and include some of the

MWSM's current accessories to minimize fabrication cost, Cox arrived at the two tier beam spring design pictured in Figure 5. Simply-supported I-beams with two equal concentrated forces symmetrically placed were chosen for the 2DOF Tuned Deck Simulator's spring elements to achieve the required stiffness while minimizing weight. The existing shipbuilding rails atop the anvil table were chosen to support the four lower tier spring beams. An intermediate structure was placed between the three upper tier spring beams and the four lower tier spring beams to achieve the required uncoupled tier frequencies and mass ratio that define the system response, and to prevent unwanted deflections and vibrations from interfering with the desired response. The intermediate structure was designed with the same mounting geometry as the shipbuilding rails on the anvil table to enable the upper and lower spring beams to be interchanged. The test object was mounted on two "equipment specific" I-beams clamped across the upper spring beams. (Cox, 1993, pp. 32-38)

Cox focused the stress analysis of the 2DOF Tuned Deck Simulator on the bending stress in the spring beams and clamps and on the tensile stress in the fasteners. Using his simulation algorithm of the 2DOF-TDS, loaded to capacity and excited with Clement's maximum anvil table acceleration of 200 g's (corresponding to a five foot hammer drop height), Cox obtained the maximum relative displacement of the spring beams and calculated the maximum bending stress in the spring beams to be 47 ksi (13 ksi in the clamps). The maximum tensile stress in the fixture bolts was 7.5 ksi. (Cox, 1993, p. 43)

Cox's design drawings of the 2DOF Tuned Deck Simulator were approved by NAVSEA and forwarded to the Naval Surface Warfare Center, Silver Springs, Md. for construction. The bill of material for the 2DOF-TDS and a schematic drawing are included in Figure 6.

4. Tunability Features of the 2DOF Tuned Deck Simulator

Adding tunability features to the 2DOF-TDS design entailed providing the means to obtain specific system natural frequencies for a variety of equipment weights by altering the stiffness-to-mass ratio of the upper and lower tiers. The upper tier frequency can be adjusted by removing the center spring beam from the upper tier and/or by altering the top load spacing (of the equipment support I-beams) from each end of the upper spring beams. The lower tier frequency is adjusted by adding ballast to the intermediate structure as necessary (without exceeding the anvil table's load limit of 7400 pounds). Cox utilized a MATHCAD® worksheet to determine the achievable system natural frequencies for various upper tier weights and 2DOF-TDS configurations. (Cox, 1993, pp. 36-47)

C. DDG-51 MODAL TESTING AND TARGET RESONANT FREQUENCIES FOR THE 2DOF TUNED DECK SIMULATOR

In September 1993, the Bath Iron Works Corporation conducted modal testing of the decks inside the combat systems equipment rooms of three DDG-51 Class ships to identify the lowest natural frequency of each deck. The transmissibility modal tests, in

which accelerations at respective deck grid points were referenced to accelerations at a fixed point on each deck, revealed deck fundamental natural frequencies between 16.5 Hz and 25 Hz (Horton, 1993, p. 20). Better quality data was later obtained during a frequency response function modal test in Combat Systems Equipment Room 3 (CSER3), where accelerations at deck grid points were referenced to the input force applied to the deck. Using STAR[®] Modal Analysis algorithms, Horton identified four natural frequencies between 14.8 Hz and 29.6 Hz and their mode shapes in the deck of CSER3 (Horton, 1993, p. 27).

Horton's findings and the existence of the coil spring Soft Deck Simulator, used for mediumweight shock testing equipment deck-mounted in submarines, with a natural frequency range of 20 to 25 Hz, led Cox to alter his target resonant frequencies for the 2DOF Tuned Deck Simulator from 60 Hz and 155 Hz to 30 Hz and 80 Hz. Cox also introduced a semi-definite 3DOF model that accounted for anvil table interaction with the deck simulator approximately 50 milliseconds after hammer impact due to the sharp "table reversal" experienced by the anvil table when meeting its vertical travel limit. The 3DOF model's shock spectra for various tier weights and a simulated hammer height of five feet displayed higher system natural frequencies at lower acceleration amplitudes than that of the 2DOF model with the same initial conditions. Cox concluded that the actual system natural frequencies should fall somewhere between those of the 2DOF and 3DOF models, respectively (Cox, 1993, p. 63).

The 2DOF-TDS was built and delivered to the Naval Undersea Warfare Center, Newport, R.I. in September 1993. The first phase of fixture characterization testing on

the MWSM began on 19 October 1993. A photograph of the 2DOF-TDS with the aluminum mounting plate and a 500 pound test weight atop the MWSM anvil table is provided in Figure 7. The test procedure, test results and a comparison between the 2DOF-TDS and the standard fixture in terms of shock spectra follow in Chapter III.

III. CHARACTERIZATION OF THE 2DOF TUNED DECK SIMULATOR

A. DESCRIPTION OF 2DOF TUNED DECK SIMULATOR TESTING

The experimental investigation into the use of the newly fabricated 2DOF-TDS involved two test phases, both conducted at NUWC, Newport, R.I. The objective of the first test phase (19-20 October 1993) was to collect data on the 2DOF-TDS during shock testing on the MWSM with test loads of 500, 1000 and 1500 pounds. These test loads atop the fixture were chosen to match load conditions of previous MWSM testing that characterized the MWSM standard fixture in June 1993 (Messina, 1993). In accordance with the MWSM Test Schedule (Table 1 in MIL-S-901D), each of the six tests in Test Phase I consisted of three groups with two blows, or hammer drops, per group.

The objective of the second test phase (01-02 February 1994) was to increase the accuracy of the acceleration shock spectra for six of the original 18 groups of blows by conducting six tests of ten blows each and averaging the respective acceleration shock spectra data. The six tests of Phase II were selected based on how well-defined the respective acceleration shock spectra peaks appeared in Phase I test results and on how well the Phase II results would best represent the diversity of hammer heights and anvil table travel limits specified in Table 1 of MIL-S-901D for the three different test weights atop the 2DOF-TDS.

The characterization of the 2DOF Tuned Deck Simulator was based on the acceleration shock spectra obtained in Test Phase II. For this reason, the description of the test procedure, presentation of test results and the comparison between the 2DOF-TDS and the standard fixture which follow will consider only Phase II data.

1. Test Schedule

The first three tests of Phase II were conducted with the 2DOF-TDS in its "3/4" configuration, meaning all three upper spring beams and four lower spring beams were in place. The latter three tests were conducted with the 2DOF-TDS in its "2/4" configuration, meaning the center spring beam in the upper tier was removed while the lower tier was unchanged.

The actual test schedule for Phase II is provided in Table 1 of Appendix B. Ten blows per test were conducted at hammer heights and anvil travel limits specified in Table 1 of MIL-S-901D based on the combined weight of the fixture, the aluminum mounting plate and the test weight (500, 1000 or 1500 pounds).

2. Data Collection and Processing

Three piezoelectric-type accelerometers were utilized during Phase II testing. The data collection system captured two seconds of data triggered after MWSM hammer release. Through post-processing, each data time record was standardized to one second in length triggered off of the initial impulse peak to which an identical negative delay was applied for all hammer drops.

The three accelerometers utilized for Phase II testing were positioned to record the acceleration at three specific locations. The accelerometer corresponding to Channel 1, Endevco Shock Accelerometer Model 7270-60K, was mounted atop the anvil

table. The accelerometer for Channel 3, Model 7270-20K, was mounted atop the fixture's intermediate structure near the center. The accelerometer for Channel 5, Model 7270-20K, mounted atop the aluminum plate next to the test weight, provided the base excitation input required for all shock spectra calculations. A block diagram of the shock data acquisition and processing instrumentation is provided in Figure 8.

Periodic fixture bolt retightening and visual checks for possible plastic yielding or cracking of fixture components were performed throughout testing. A four foot level was also used to verify that upper and lower spring beams remained straight, particularly after blows from higher hammer heights. The accelerometer for Channel 3 on the fixture's intermediate structure appeared to saturate after the first blow of Test 3 (with a test weight of 1500 pounds and a hammer height of 4.5 feet), and was replaced with a spare Model 7270-60K accelerometer. Phase II testing was completed with the fixture intact in its original condition.

B. PHASE II DATA REDUCTION

Of the 180 data files collected for the three accelerometer channels during 60 blows of Phase II testing, five data files were not usable due to signal analyzer input voltage overload. Of the three accelerometer channels recorded, Channel 5, which measured the acceleration at the base of the test weight, provided the "output" of the 2DOF-TDS and, therefore, the "input" to the test weight atop the 2DOF-TDS. The test weight, representing a combat systems component requiring shock testing, was modeled as an

undamped single DOF system subjected to a base excitation for all subsequent absolute acceleration shock spectra calculations.

1. Absolute Acceleration Shock Spectra Determination Using MATLAB®

The MATLAB® program, originally developed by Cox to calculate shock spectra, is contained in Appendix C.1. The absolute acceleration shock spectra were obtained through the simulation of a linear time-varying state-space model characterized by two equations:

$$\dot{x}(t) = A(t)x(t) + B(t)u(t) \quad (1)$$

$$y(t) = C(t)x(t) + D(t)u(t) \quad (2)$$

where $u(t)$ is the input vector, $y(t)$ is the output vector, and $x(t)$ is the state vector. The matrices $A(t)$, $B(t)$, $C(t)$, and $D(t)$ are the state matrix, input matrix, output matrix, and direct transmission matrix, respectively (Ogata, 1992, p. 289). The equation of motion for an undamped single-DOF system subjected to base excitation was chosen to represent the test weight atop the 2DOF-TDS on the MWSM.

$$\ddot{y}(t) + \omega_n^2 y(t) = -\ddot{z}(t) \quad (3)$$

In Equation (3), $y(t)$ and $\dot{y}(t)$ represent the relative displacement and the relative acceleration, respectively, between the top of the 2DOF-TDS and the center of mass of the test weight. The single DOF system natural frequency in radians per second is represented as ω_n . The absolute acceleration input, $\ddot{z}(t)$, is the acceleration time history

recorded by accelerometer Channel 5 located atop the aluminum plate near the base of the test weight.

In order to write Equation (3) in the general form of the state-space model defined in Equations (1) and (2), let:

$$\mathbf{x}(t) = \begin{bmatrix} y(t) \\ \dot{y}(t) \end{bmatrix} \quad (4a)$$

and

$$\dot{\mathbf{x}}(t) = \begin{bmatrix} \dot{y}(t) \\ \ddot{y}(t) \end{bmatrix} \quad (4b)$$

$$\mathbf{y}(t) = [\ddot{y}(t)] \quad (5a)$$

and

$$\mathbf{u}(t) = [\ddot{z}(t)] \quad (5b)$$

and substitute Equations (4) and (5) into Equations (1) and (2), to obtain the state-space matrix representation of the undamped single DOF system atop the 2DOF-TDS in Equations (6) and (7).

$$\dot{\mathbf{x}}(t) = \begin{bmatrix} \dot{y}(t) \\ \ddot{y}(t) \end{bmatrix} = \begin{bmatrix} 0 & I \\ -\omega_s^2 & 0 \end{bmatrix} \begin{bmatrix} y(t) \\ \dot{y}(t) \end{bmatrix} + \begin{bmatrix} 0 \\ -I \end{bmatrix} \ddot{z}(t) \quad (6)$$

$$y(t) = [\dot{y}(t)] = [-\omega_n^2 \quad 0] \begin{bmatrix} y(t) \\ \dot{y}(t) \end{bmatrix} + [-I] [\bar{z}(t)] \quad (7)$$

The "lsim" command in the MATLAB® Control System Toolbox was then used to calculate the acceleration time response of the undamped single-DOF system to input $u(t)$, which contains the absolute acceleration data from accelerometer Channel 5. The MATLAB® code statement:

$$[yspec]=lsim(E, F, GG, H, accel, t) \quad (8)$$

utilizes the input variables (E, F, GG, H, accel, t) to calculate an output, yspec, which is the relative acceleration of the system for a specified system natural frequency calculated at each time for which the base acceleration was recorded on Channel 5. The variables, E, F, GG and H, correspond to the coefficients of state-space matrix Equations (6) and (7) which in turn correspond to the coefficients of Equations (1) and (2), or A, B, C and D, respectively. The accel input is the actual recorded accelerometer Channel 5 data converted into an ASCII code file. This file contained 2048 consecutive, equally-spaced samples of the input acceleration over a sample duration of one second. The t input is the one second sample duration divided into discrete sample intervals of 0.4883 milliseconds.

The relative acceleration yspec was then added to the absolute acceleration input accel recorded at the base of the test weight to obtain the absolute acceleration of

the single-DOF system, `xspec`. Since the absolute maximum response of the undamped single-DOF system was required, the MATLAB® program code:

$$\text{maxspec}(i)=\text{max}(\text{abs}(\text{xspec})) \quad (9)$$

stores the largest value of absolute acceleration computed at each system natural frequency in the array `maxspec`. The absolute acceleration shock spectra for each blow was then plotted versus system natural frequency. The frequency band of interest in the characterization of the 2DOF-TDS was 0 to 150 Hz stepped in 1 Hz increments.

2. Resultant Shock Spectra from Phase II Tests

An illustration of the acceleration time history recorded on Channel 5 for Test 4 Blow 7 over the resultant shock spectra is presented in Figure 9. Additionally, Figures 10 through 15 contain the shock spectral plots for the respective six tests. In all tests with the exception of Test 1 and Test 5, shock spectra from at least one of the ten blows were not plotted due either to abnormal variance in peak amplitude from the norm or to signal analyzer input voltage overload during that particular blow.

While Phase II test results in the form of shock spectra do characterize the 2DOF Tuned Deck Simulator over six sets of test conditions, these results do not reveal the potential advantages of using the 2DOF-TDS in place of the standard fixture. In order to appreciate the value of the 2DOF-TDS to shock qualification, a comparison between shock spectra generated by the MWSM and standard fixture and those generated in Test Phase II by the MWSM and 2DOF-TDS under similar test conditions follows.

C. STANDARD FIXTURE SPECTRA VERSUS 2DOF TUNED DECK SIMULATOR SPECTRA

This comparison utilized the acceleration data obtained by the Naval Undersea Warfare Center (NUWC), New London, Conn. in a June 1993 test series to characterize the MWSM with standard fixture and the acceleration data from Phase II of the 2DOF-TDS characterization shock tests. The shock spectra generated by the fixtures were compared for test weights of 500 and 1000 pounds. In both cases, the 300 pound aluminum plate was attached to the top of each fixture to support the test weight.

1. Comparison of Shock Spectra with Test Weight of 500 Pounds

For the 500 pound test, the 2DOF-TDS was configured with three upper spring beams and four lower spring beams. Since the 2DOF-TDS weighed more than the standard fixture, compliance with Table 1 of MIL-S-901D required that the hammer height for the 2DOF-TDS test be one foot higher than that of the standard fixture test. The anvil table travel limit was set at three inches for both tests. The accelerometer used for calculating shock spectra was mounted on the aluminum plate adjacent to the test weight.

Figure 16 depicts the differences in the respective shock spectra. The first spectral peak for the MWSM and standard fixture occurred at 78 Hz with an acceleration of 307 g's. The first peak for the MWSM and 2DOF-TDS occurred at 64 Hz with an acceleration of 2017 g's. Similarly, the standard fixture's second peak occurred at 162 Hz with an acceleration of 180 g's; the 2DOF-TDS second peak occurred at 102 Hz with an acceleration of 1083 g's.

2. Comparison of Shock Spectra with Test Weight of 1000 Pounds

For the 1000 pound test weight, the center spring beam in the upper tier of the 2DOF-TDS was removed. The hammer heights for the standard fixture and 2DOF-TDS were 2.25 feet and 3.5 feet, respectively. The anvil table travel limit for both tests was 1.5 inches.

Figure 17 depicts the differences in the respective shock spectra. The MWSM and standard fixture generated shock spectral peaks at 63 Hz (245 g's), 118 Hz (340 g's) and 184 Hz (772 g's). The MWSM and 2DOF-TDS spectral peaks occurred at 51 Hz (1472 g's), 90 Hz (551.8 g's) and 122 Hz (440 g's).

3. Summary of Observations

In both shock spectra comparisons, the 2DOF-TDS tests required higher hammer drop heights because the 2DOF-TDS weighed more than the standard fixture. In both the 500 and 1000 pound tests, the 2DOF-TDS transmitted shock spectra contained initial and secondary peaks of greater amplitude and at lower frequencies than those transmitted by the standard fixture. A summary of comparison results for the first and second spectral peaks follows:

• 500 POUND TEST WEIGHT:

- ⇒ Amplitude of first spectral peak of 2DOF-TDS was over 6.5 times greater than that of standard fixture.
- ⇒ Frequency of first spectral peak of 2DOF-TDS was 14 Hz lower than that of standard fixture.

- ⇒ Amplitude of second spectral peak of 2DOF-TDS was six times greater than that of standard fixture.
- ⇒ Frequency of second spectral peak of 2DOF-TDS was 60 Hz lower than that of standard fixture.

• 1000 POUND TEST WEIGHT:

- ⇒ Amplitude of first spectral peak of 2DOF-TDS was six times greater than that of standard fixture.
- ⇒ Frequency of first spectral peak of 2DOF-TDS was 12 Hz lower than that of standard fixture.
- ⇒ Amplitude of second spectral peak of 2DOF-TDS was over 1.5 times greater than that of standard fixture.
- ⇒ Frequency of second spectral peak of 2DOF-TDS was 28 Hz lower than that of standard fixture.

It should be noted that the amplitude of the standard fixture's third spectral peak was over 1.7 times greater than that of the 2DOF-TDS. The frequency of the third spectral peak of the standard fixture was 62 Hz higher than that of the 2DOF-TDS.

4. Discussion of Results

According to Clements, increasing the height of the hammer drop raises the level of the shock spectrum without changing its shape, while increasing the load weight reduces shock severity for frequencies below 200 Hz (Clements, 1972, pp. 94-95). Clements also regarded anvil table travel limits as having no consistent effect on the generated shock spectra. This limited comparison between shock spectra generated by the

standard fixture and the 2DOF-TDS neither supports nor disputes Clements' description of MWSM shock phenomena. The removal of the center spring beam in the 2DOF-TDS upper tier and the structural interaction between tiers were not available for Clements to characterize. Nonetheless, this comparison does address the issue of which MWSM addition, the standard fixture or the 2DOF Tuned Deck Simulator, more realistically simulates the actual shock phenomena experienced by deck-mounted equipment.

If the ultimate objective is to enable the MWSM to reproduce shock spectra with at least two dominant spectral peaks at the relatively lower frequencies typically transmitted through a ship's superstructure during shock trials, the 2DOF Tuned Deck Simulator approaches this objective more closely than the standard fixture. Incorporating the 2DOF-TDS into current shock qualification procedures is the focus of Chapter IV.

IV. SHOCK QUALIFICATION AND THE 2DOF TUNED DECK SIMULATOR

The 2DOF Tuned Deck Simulator for the MWSM was designed and built to excite combat systems equipment with most of the energy concentrated at two dominant resonant frequencies pre-selected from actual ship class shock trial spectral analysis or from modal analysis at the equipment's designated location aboard ship. Cox based his 2DOF-TDS design on the ability to generate dominant acceleration shock spectral peaks at 30 Hz and 80 Hz, respectively (Cox, 1993, pp. 28-29). The lowest frequency associated with an initial spectral peak generated in Phase II characterization testing was 43 Hz (achieved during Test 4 blows).

This chapter presents the actual frequencies of shock spectral peaks achieved with the 2DOF-TDS on the MWSM during Phase II testing and compares these frequencies with those obtained using the 2DOF Tuned Deck Simulator's MATLAB[®] and MATHCAD[®] models, respectively. The 2DOF-TDS compatibility with current mediumweight shock qualification procedures and its potential integration into MIL-S-901D are also explored.

A. PHASE II ACCELERATION SHOCK SPECTRAL PEAKS

The absolute acceleration shock spectra for blows in Test 1 through Test 6, depicted in Figures 10 through 15, reveal at least two (in most cases, three) distinct spectral peaks.

The average absolute acceleration shock spectra for each Phase II test and the corresponding “modeled” average absolute acceleration shock spectra using a MATLAB® model of the 2DOF Tuned Deck Simulator are depicted in Figures 18 through 23.

1. Effects of Averaging Absolute Acceleration Shock Spectra

The primary objective of Test Phase II was to increase the accuracy of the acceleration shock spectra that best characterized the 2DOF-TDS on the MWSM. By increasing the sample size of each test from two hammer drops (in Phase I) to ten drops (in Phase II) and averaging the resultant shock spectra for each test, one would expect a reduction in the average random noise in the data and an increase in spectral peak definition.

In almost all tests, however, the initial spectral peaks survived the averaging process intact, but the second spectral peaks were either greatly diminished or vanished completely after averaging. For example, Figure 10 depicts the absolute acceleration shock spectra for the ten drops in Test 1. A second spectral peak at 102 Hz, clearly evident in Figure 10, is conspicuously missing from the average shock spectra plot in Figure 18. Since all Phase II acceleration data files were standardized in post-processing to a one second time record triggered off of the initial impulse peak and adjusted with the same negative time delay, trigger initiation during data collection was not a contributing factor in the reduction or loss of second spectral peaks upon averaging. Instead, slight phase shifts are evident in Figures 10 through 15 between the second spectral peaks of various drops in each test. When averaging the absolute acceleration values for the respective spectra in each test, any “out-of-phase” second spectral peaks could effect a

reduction in second peak amplitude. Possible causes of the phase shifts include: non-uniform bolt tightening on the 2DOF-TDS between hammer drops; and slight weight shifts of the 500 pound lead weights representing the test object atop the 2DOF-TDS.

2. “Modeled” Average Absolute Acceleration Shock Spectra

In addition to displaying the “actual” average absolute acceleration shock spectra for each Phase II test, Figures 18 through 23 also present the “modeled” average absolute acceleration shock spectra. The MATLAB® model, used for the comparison between “actual” average and “modeled” average, was originally developed by Cox (Cox, 1993, pp. 109-112). This model was updated with the actual 2DOF-TDS tier weights and modified to input actual Phase II acceleration data (Channel 1) obtained at the top of the anvil table instead of the half-sine wave vertical acceleration impulse of one millisecond duration (used previously by Clements and Corbell). Cox estimated the value of the critical damping ratio (ζ) for the 2DOF-TDS to be between three and five percent (Cox, 1993, p.23). The MATLAB® model was again updated after a logarithmic decrement calculation for ζ using acceleration time histories obtained during Phase I testing yielded an average ζ of 0.035.

The MATLAB® program that modeled 2DOF Tuned Deck Simulator behavior under the same initial conditions as Phase II Test 1 and produced Figure 18 is provided in Appendix C.2. The absence of a second spectral peak in the “modeled” average spectra for Test 4 (Figure 21) indicated that the “modeled” average spectra were also vulnerable to the effects of “out-of-phase” second spectral peaks.

3. Determining System Natural Frequencies Using MATHCAD®

A MATHCAD® worksheet was utilized by Cox to determine the achievable system natural frequencies for various upper tier weights and 2DOF-TDS configurations (Cox, 1993, pp. 106-107). The MATHCAD® worksheet for the first and second system natural frequencies generated under the conditions of Test 1 is provided in Appendix C.3.

The 2DOF-TDS in Test 1 was configured with all upper and lower spring beams installed and with a 500 pound lead weight atop the aluminum support plate. The spring stiffness per spring beam was calculated using the beam bending formula for a simply supported beam with two equal concentrated forces symmetrically placed. The upper tier stiffness and lower tier stiffness were obtained by multiplying the spring stiffness per beam by the respective number of spring beams per tier. After entering the actual weights of the upper tier, intermediate structure and anvil table, the tier natural frequencies and system natural frequencies were computed.

B. FREQUENCIES OF SHOCK SPECTRAL PEAKS

1. Methods Utilized

The frequencies of the absolute acceleration shock spectral peaks in Test Phase II were determined using three methods, specifically: by graphically estimating spectral peak locations in Figures 10 through 15; by averaging the respective shock spectra of each test and determining spectral peak locations from the average shock spectra plots in Figures 18 through 23; and by averaging the MATLAB® “modeled” shock spectra of each test and determining spectral peak locations from the “modeled” shock

spectra plots also in Figures 18 through 23. Comparative summaries of spectral peak locations, including the system natural frequencies from MATHCAD® worksheets, for Tests 1 through 6 are provided in Tables 2 through 13.

Due to the effects of “out-of-phase” second spectral peaks on shock spectra averaging, the most accurate spectral peak locations were obtained via the graphical estimation method using Figures 10 through 15. The spectral peak locations obtained from the “modeled” average shock spectra for each test were included in the summary tables to illustrate how closely the MATLAB® model’s average spectral peak locations matched those obtained via graphical estimation. Since the input to the MATLAB® model (in Appendix C.2) was acceleration recorded on the anvil table, the “modeled” shock spectra were considered less accurate than the actual shock spectra based on acceleration recorded at the base of the test weight atop the 2DOF-TDS.

The two system natural frequencies obtained via the MATHCAD® worksheet (in Appendix C.3) were also included in Tables 2 through 13. These frequencies characterized the undamped free vibration of the system from the hammer impact point on the anvil table to the center of mass of the test weight on the 2DOF-TDS. Cox demonstrated the usefulness of his MATHCAD® worksheet by determining the range of system natural frequencies attainable for a specified equipment weight atop the 2DOF Tuned Deck Simulator (Cox, 1993, pp. 46-47).

2. Comparison Between Methods

Some interesting trends are apparent among the frequencies of shock spectral peaks displayed in Tables 2 through 13. For each of the six tests, the frequencies of the first spectral peaks, determined via the four respective methods, were practically identical. Although a second spectral peak was apparent in the average shock spectra for four of the six tests (depicted in Figures 18 through 23), the amplitude of each second peak was significantly lower than that of the corresponding actual shock spectra (in Figures 10 through 15). This reduction in average acceleration amplitude was attributed to the phase differences between various second spectral peaks and their effect on spectra averaging.

Regarding the spectral peak locations from the graphical estimate method as the most accurate, the proximity of second spectral peak locations relative to those obtained via the graphical estimate method revealed two other trends. Specifically, the second spectral peaks from the MATLAB® “modeled” average method (with the exception of Test 4), occurred an average of 9.4 Hz higher than those from the graphical estimate method. The MATHCAD®-derived second natural frequency of the 2DOF-TDS was an average of 12.67 Hz greater than the frequency of the second spectral peak from the graphical estimate method for all six tests.

Although this characterization of the 2DOF Tuned Deck Simulator and validation of its MATLAB® model were limited to six tests on the MWSM, the 2DOF-TDS can be integrated into the mediumweight shock qualification specifications of MIL-S-901D.

C. 2DOF TUNED DECK SIMULATOR COMPATIBILITY WITH MIL-S-901D

1. Basic Requirements

In order to be compatible with the current test schedule and fixture requirements for mediumweight shock testing in MIL-S-901D, the total weight on the anvil table must not exceed 7400 pounds; and the 2DOF-TDS must accommodate the standard inclined fixture in order to simulate shipboard shock loadings in the athwartship direction (MIL-S-901D, 1989, pp. 16-17). The 2DOF-TDS with all spring beams installed (and the aluminum plate removed) weighs 2675 pounds. The standard inclined fixture, which can be easily mounted onto the 2DOF-TDS at the two I-beams which cross the upper tier spring beams, weighs 715 pounds. Since three out of the six hammer blows must be conducted with the tested item in the inclined position, the test item's weight is limited to 4010 pounds when mounted on the 2DOF-TDS.

MIL-S-901D further stipulates that fixtures intended to simulate deck-mounted conditions shall possess a fundamental response frequency (with test item mounted) not lower than 25 Hz and that any plastic yielding or cracking of fixtures is unacceptable (MIL-S-901D, 1989, p. 13). The lower limit on 2DOF-TDS fundamental response frequency is not considered restrictive as the 2DOF-TDS design's target frequency was 30 Hz, and the lowest frequency attained during both Test Phases I and II was 43 Hz.

2. Maximum Bending Stress Versus Yield Strength

Regarding plastic yielding or cracking of the 2DOF-TDS, the spring beams were made of carbon steel with a yield strength of 50 ksi. All other structural elements (in Figure 6) were made of mild steel with a yield strength of 36 ksi. A total of 84 zinc-plated steel socket head bolts (1-8UNC x 4.25 inches) were used in the construction of the 2DOF-TDS.

Cox predicted a maximum bending stress in the spring beams of 47 ksi based on his MATLAB[®] model of the 2DOF-TDS, loaded to its full weight capacity and excited with Clements' maximum expected anvil acceleration of 200 g's for a five foot hammer drop (Cox, 1993, pp. 39-43). During Test Phase I, however, after a hammer drop of 3.75 feet with a test weight of 1500 pounds atop the 2DOF-TDS (in "2/4" configuration), a deflection of approximately $\frac{1}{8}$ of an inch at the center of the upper spring beam nearest the MWSM hammer was observed. The effected spring beam was subsequently straightened, and testing continued without incident.

Although this spring beam deflection was attributed to a slight lateral shift toward the hammer end of the MWSM of the test weights (three 500 pound lead cylinders stacked vertically on the aluminum plate) prior to the 3.75 foot hammer drop, the total weight on the anvil table for this Phase I test was 4499 pounds, equating to 60 percent of anvil table capacity. The 3.75 foot height for this test equates to 68 percent of the maximum hammer height prescribed by MIL-S-901D. No beam deflection or test weight lateral movement was observed during Test Phase II; however, the hammer height for the

ten drops in Phase II Test 4 (with a test weight of 1500 pounds atop the 2DOF-TDS in “2/4” configuration), was only 2.25 feet.

Since the possibility that at least one of the 2DOF-TDS spring beams could plastically deform during a shock test at greater than 70 percent of MWSM capacity has not been ruled out, a half-bridge strain gage configuration (with two active arms for the respective I-beam flange surfaces and with temperature compensation) could be mounted at the center of both an upper tier and a lower tier spring beam. The 2DOF-TDS in the “2/4” and “3/4” configurations could then be incrementally loaded to capacity and shock tested at MIL-S-901D specified hammer heights in order to determine the maximum bending stress in the spring beams. Should the maximum bending stress exceed the 50 ksi yield strength of carbon steel and/or plastic deformation occur during shock testing, some restrictions on equipment test weight and hammer height when using the 2DOF-TDS may be required. To avoid these restrictions, the spring beams could be made from steels with higher yield strengths.

3. Compatibility Achieved

Based purely on the results of Test Phase II (i.e., barring the possibility of spring beam deformation under other than Phase II test conditions), the 2DOF Tuned Deck Simulator meets the current MWSM test schedule and fixture requirements of MIL-S-901D.

For the 2DOF Tuned Deck Simulator to be fully compatible with MIL-S-901D and utilized to its full potential, the mediumweight shock test criteria for deck-mounted equipment should reflect the ultimate design goal for the 2DOF-TDS; that is to

excite combat systems equipment with most of the energy concentrated at two dominant resonant frequencies pre-selected from actual ship class shock trial spectral analysis or from modal analysis at the equipment's designated location aboard ship. Only under this context would the 2DOF-TDS offer significant advantages over the standard fixture in mediumweight shock qualification. A proposal for the integration of the 2DOF-TDS into MIL-S-901D is contained in Chapter V.

V. CONCLUSION

This experimental investigation into the dynamic response of the 2DOF Tuned Deck Simulator has proved that the 2DOF-TDS can be successfully integrated into the U.S. Navy's mediumweight shock qualification program. Unlike the standard fixture for the MWSM, the 2DOF-TDS demonstrated the potential to excite combat systems equipment with most of the energy concentrated at two dominant resonant frequencies pre-selected from actual ship class shock trial spectral analysis or from modal analysis at the equipment's designated location aboard ship.

A. PROJECTED UTILIZATION OF THE 2DOF TUNED DECK SIMULATOR

With the emphasis now on transmitting a high acceleration impulse at both the first and second resonant frequencies (characteristic of a specific shipboard location) into the base of a combat systems component via the 2DOF Tuned Deck Simulator, the current test schedule for the MWSM in Table 1 of MIL-S-901D can be simplified (MIL-S-901D, 1989, p. 17). Instead of requiring three groups of two blows each at various hammer heights and anvil table travel limits, the test schedule could require just two groups of two blows each, in which the hammer height and anvil table travel limit were based only on the desired primary and secondary resonant frequencies and on the total weight on the anvil table.

For both Group I blows, the test item would be mounted in its normal attitude atop the 2DOF-TDS to simulate shock loadings in the vertical direction. For both Group II blows, the test item would be mounted on the standard inclined fixture atop the 2DOF-TDS to simulate shock loadings in the athwartship direction. The test item would be operated in its normal mode during the first blow and in its alternate mode during the second blow of each group.

B. PROPOSED ADDENDUM TO MIL-S-901D

1. Proposed Test Schedules

A proposed addendum to the mediumweight shock qualification procedures in MIL-S-901D based solely on Phase II test data is provided in Tables 14 and 15. The test schedule in Table 14 applies when the initial and second spectral peaks occur within the ranges of 45 - 55 Hz and 90 - 100 Hz, respectively. The test schedule in Table 15 applies when the initial and second spectral peaks occur within the ranges of 55 - 65 Hz and 90 - 100 Hz, respectively. Directions for computing the "Total Weight on the Anvil Table" are listed after Table 15.

2. Need for Expanded Coverage

Before the proposed addendum could be integrated into MIL-S-901D as a test schedule for the MWSM, Tables 14 and 15 would have to be expanded to cover greater ranges of equipment weights and spectral peak frequencies. More diverse characterization testing of the 2DOF-TDS using multiple "tuning" features under a wider range of test weights would be necessary.

Since the MATHCAD® worksheet (in Appendix C.3) enables the user to “tune” the 2DOF-TDS model by removing the center spring beam from the upper tier, by altering the load application points on the upper spring beams, or by adding ballast to the intermediate structure, the MATHCAD® worksheet would be useful in the formulation of a prediction-based test plan for a final phase of 2DOF-TDS characterization testing.

3. Environmental Issues

The future integration of the 2DOF-TDS into mediumweight shock qualification procedures may be driven more by environmentalists who oppose ship shock trials than by NAVSEA proponents of more accurate shock qualification methods. According to a 14 February 1994 article in the *San Francisco Chronicle*, an ad hoc group of environmentalists are exploring legal challenges to the shock trial of DDG-53, originally scheduled to occur in March 1994 in an offshore test range whose border was approximately six miles from the Channel Islands National Marine Sanctuary off the California coast (Martin, 1994, p.13).

The U.S. Navy's commitment to conducting surface ship shock trials on one ship of each shock hardened class remains steadfast (NAVSEA , 1989, pp 2-4). The Commanding Officer of an AEGIS guided missile cruiser that underwent shock trials in 1984 commented that ship shock trials are cost effective and minimize future risk and casualties (Anderson, 1987, p. 39).

If the courts side with the environmentalists, and the Navy is unable to conduct shock trials in areas deemed safe by environmental groups, more accurate shock qualification may become the only feasible alternative for the near term. Since equipment

operability following shock is verified after mediumweight shock test blows, the 2DOF Tuned Deck Simulator and MWSM could provide the more accurate and comprehensive method of mediumweight shock qualification.

C. RECOMMENDATIONS

While the 2DOF-TDS is compatible with the mediumweight shock qualification requirements and procedures of MIL-S-901D, an additional test phase on the MWSM is necessary to completely characterize the 2DOF-TDS under test weights and "tuning" configurations other than those previously tested. The MATHCAD® worksheet in Appendix C.3 would be useful in formulating a prediction-based test schedule for future characterization testing.

As part of a future test phase, strain gages should be mounted on upper and lower tier spring beams of the 2DOF Tuned Deck Simulator to determine the maximum bending stress in the spring beams during shock testing. Should the maximum bending stress exceed the 50 ksi yield strength of carbon steel and/or plastic deformation occur during shock testing, some restrictions on equipment test weight and hammer height when using the 2DOF-TDS may be required. To avoid these restrictions, the spring beams could be made from steels with higher yield strengths.

In addition to expanding the characterization of the 2DOF-TDS to complete the proposed addendum to MIL-S-901D, one possible direction for new research is the development of a MWSM fixture capable of generating a first spectral peak between 25 and 40 Hz.

Once completed and approved, the addendum to MIL-S-901D for the utilization of the 2DOF Tuned Deck Simulator should provide a quantum improvement in the simulation of a ship's actual response to an underwater explosion for the pre-acceptance shock qualification of combat systems equipment. This improvement promises to enhance the capacity of a warship to absorb damage and still maintain its mission integrity.

APPENDIX A: FIGURES

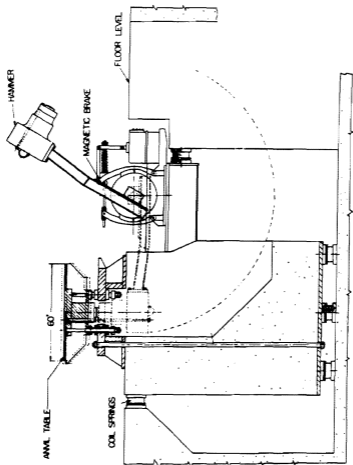

**Figure 1. The Navy High-Impact Shock Machine for Mediumweight (MWSM).
The Dotted Line Shows Hammer Path (Courtesy of Clements).**

DDG-51 Pretrial Prediction Versus MWSM with Standard Fixture

- NOTES: (1) Prediction for SPY-1D Beam Programmer (1000 lbs)
(2) Weight on MWSM Standard Fixture = Approx. 1300 lbs
(3) MWSM Hammer Height = 2.25 ft; Anvil Travel Limit = 3 in
(4) 400 Hz Bessel Filter Used in MWSM Test

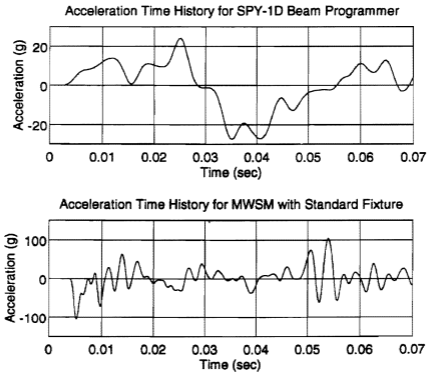

Figure 2. DDG-51 Pretrial Predicted Acceleration Time History Versus MWSM with Standard Fixture Actual Acceleration Time History.

DDG-51 Pretrial Prediction Versus MWSM with Standard Fixture

- NOTE: (1) Prediction for SPY-1D Beam Programmer (1000 lbs)
(2) Weight on MWSM Standard Fixture = Approx. 1300 lbs
(3) MWSM Hammer Height = 2.25 ft; Anvil Travel Limit = 3 in
(4) 400 Hz Bessel Filter Used in MWSM Test

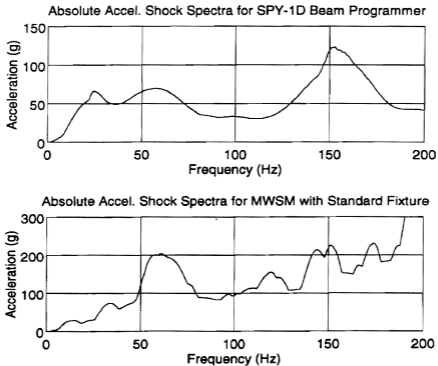

Figure 3. DDG-51 Pretrial Predicted Absolute Acceleration Shock Spectra Versus MWSM with Standard Fixture Actual Absolute Acceleration Shock Spectra.

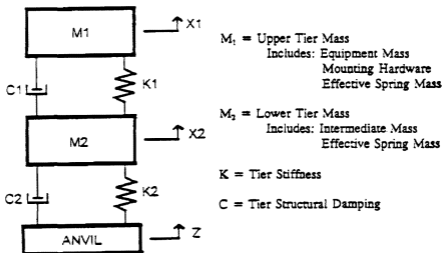

Figure 4. Model of 2DOF Tuned Deck Simulator as Two Mass-Spring-Damper Systems Coupled Together (Courtesy of Cox).



**Figure 5. 1/4 Scale Model of the 2DOF Tuned Deck Simulator for the MWSM.
(Courtesy of Cox).**

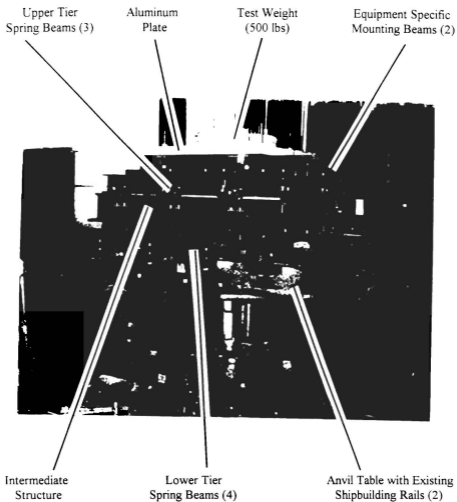

Figure 7. Photograph of 2DOF Tuned Deck Simulator with Aluminum Mounting Plate and 500 Pound Test Load atop the MWSM Anvil Table.

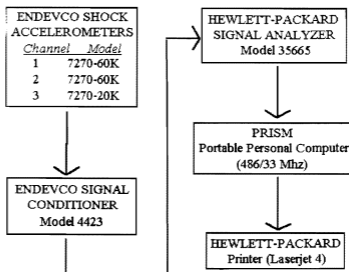

Figure 8. Block Diagram of Test Phase II Shock Data Acquisition and Processing Instrumentation.

MWSM 2DOF Tuned Deck Simulator - Test 4 Blow 7

Spring Beam Configuration: 2 Upper / 4 Lower

Test Weight on Deck Simulator: 1500 lbs

Total Weight on Anvil Table: 4389 lbs

MWSM Hammer Ht: 2.25 ft (Anvil Travel = 3 in)

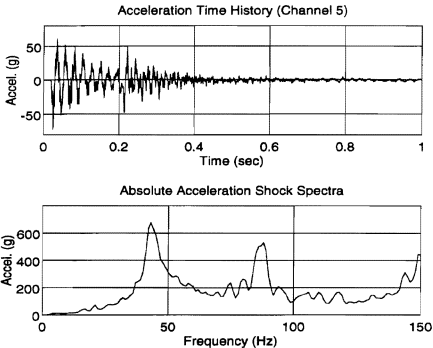

Figure 9. Acceleration Time History (Channel 5) and Absolute Acceleration Shock Spectra for Test 4 Blow 7.

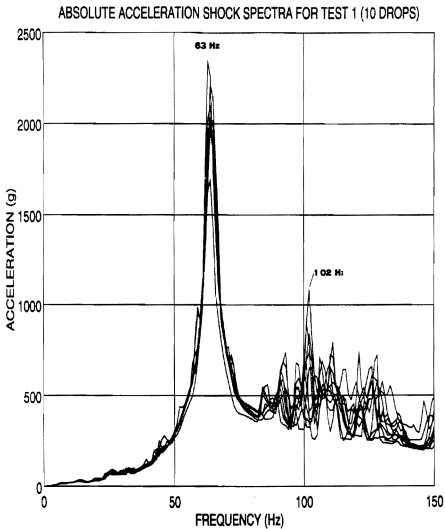

Figure 10. Absolute Acceleration Shock Spectra for Test 1 (10 Drops).

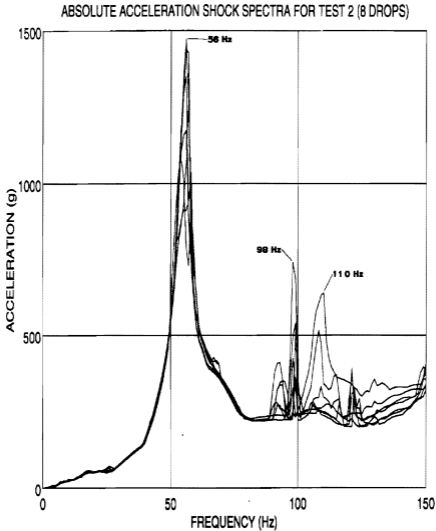

Figure 11. Absolute Acceleration Shock Spectra for Test 2 (8 Drops).

ABSOLUTE ACCELERATION SHOCK SPECTRA FOR TEST 3 (9 DROPS)

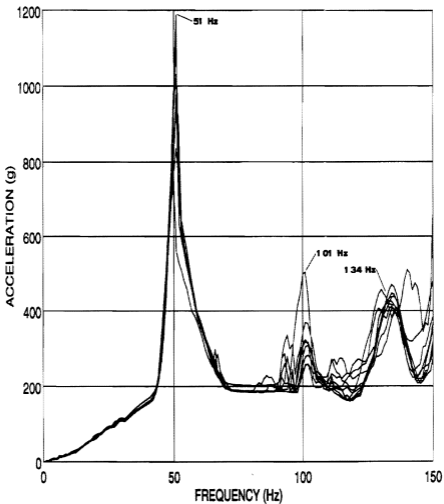

Figure 12. Absolute Acceleration Shock Spectra for Test 3 (9 Drops).

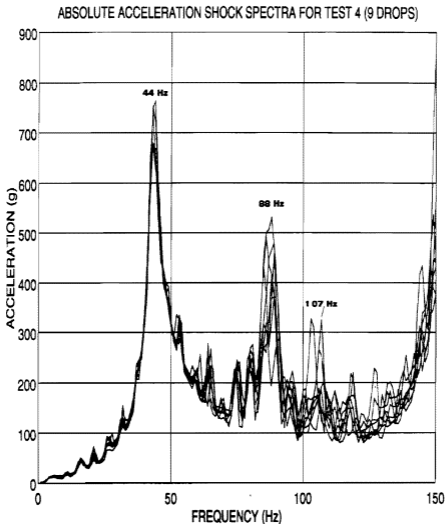

Figure 13. Absolute Acceleration Shock Spectra for Test 4 (9 Drops).

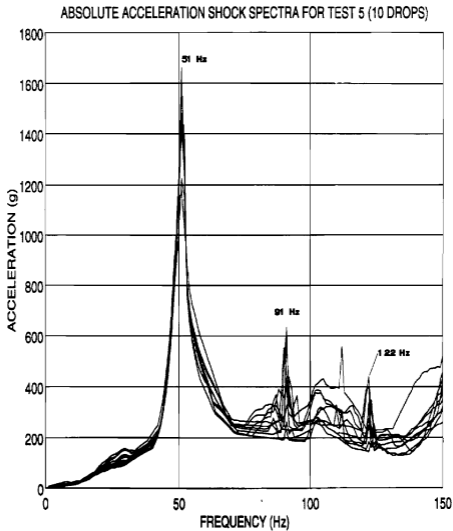

Figure 14. Absolute Acceleration Shock Spectra for Test 5 (10 Drops).

ABSOLUTE ACCELERATION SHOCK SPECTRA FOR TEST 6 (9 DROPS)

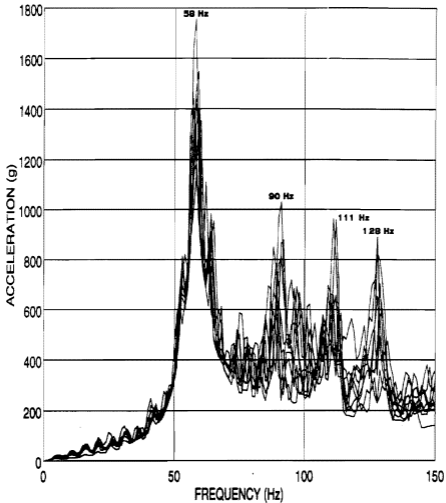

Figure 15. Absolute Acceleration Shock Spectra for Test 6 (9 Drops).

Standard Fixture Versus 2DOF Deck Simulator (3/4 Configuration)

- NOTE: (1) Aluminum Plate (300 lbs) Supports Test Weight.
(2) Test Weight atop Aluminum Plate = 500 lbs.
(3) Hammer Ht (HH) and Anvil Travel (AT) per MIL-S-901D.
(4) 400 Hz Bessel Filter Used in Standard Fixture Test.

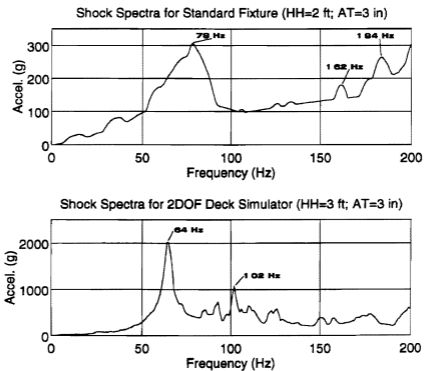

Figure 16. Standard Fixture Versus 2DOF Tuned Deck Simulator (3/4 Configuration).

Standard Fixture Versus 2DOF Deck Simulator (2/4 Configuration)

NOTE: (1) Aluminum Plate (300 lbs) Supports Test Weight.

(2) Test Weight atop Aluminum Plate = 1000 lbs.

(3) Hammer Ht (HH) and Anvil Travel (AT) per MIL-S-901D.

(4) 400 Hz Bessel Filter Used in Standard Fixture Test.

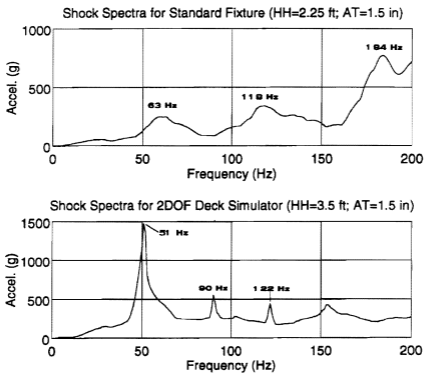

Figure 17. Standard Fixture Versus 2DOF Tuned Deck Simulator (2/4 Configuration).

2DOF Tuned Deck Simulator - Test 1

Spring Beam Configuration: 3 Upper / 4 Lower

Test Weight on Deck Simulator: 500 lbs

Total Weight on Anvil Table: 3494 lbs

MWSM Hammer Ht: 3 ft (Anvil Travel = 3 in)

10 of 10 Hammer Drops Used for Average.

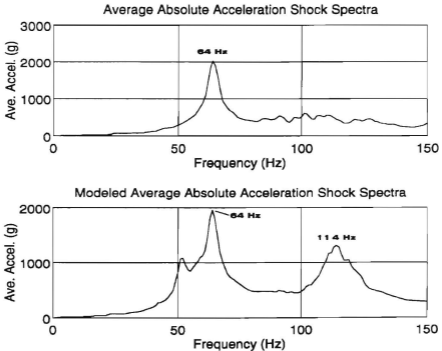

Figure 18. Average Absolute Acceleration Shock Spectra Versus “Modeled” Average Acceleration Shock Spectra for Test 1.

2DOF Tuned Deck Simulator - Test 2

Spring Beam Configuration: 3 Upper / 4 Lower

Test Weight on Deck Simulator: 1000 lbs

Total Weight on Anvil Table: 3994 lbs

MWSM Hammer Ht: 3.5 ft (Anvil Travel = 1.5 in)

8 of 10 Hammer Drops Used for Average.

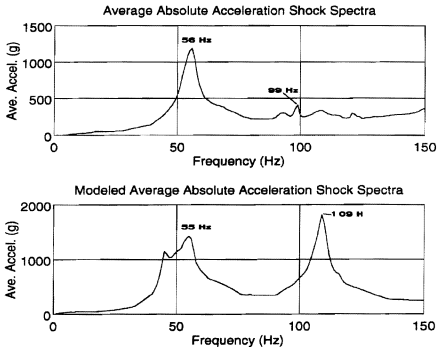

Figure 19. Average Absolute Acceleration Shock Spectra Versus "Modeled" Average Acceleration Shock Spectra for Test 2.

2DOF Tuned Deck Simulator - Test 3

Spring Beam Configuration: 3 Upper / 4 Lower

Test Weight on Deck Simulator: 1500 lbs

Total Weight on Anvil Table: 4494 lbs

MWSM Hammer Ht: 4.5 ft (Anvil Travel = 1.5 in)

9 of 10 Hammer Drops Used for Average.

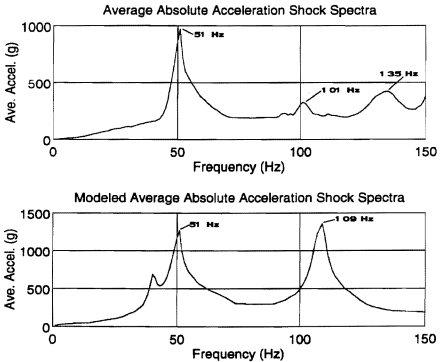

Figure 20. Average Absolute Acceleration Shock Spectra Versus “Modeled” Average Acceleration Shock Spectra for Test 3.

2DOF Tuned Deck Simulator - Test 4

Spring Beam Configuration: 2 Upper / 4 Lower

Test Weight on Deck Simulator: 1500 lbs

Total Weight on Anvil Table: 4389 lbs

MWSM Hammer Ht: 2.25 ft (Anvil Travel = 3 in)

9 of 10 Hammer Drops Used for Average.

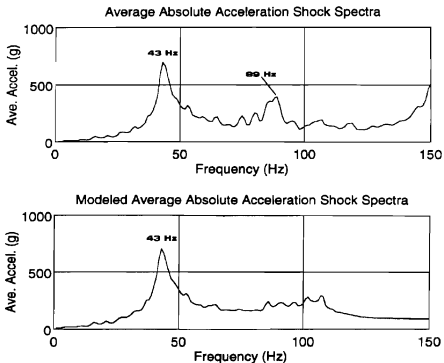

Figure 21. Average Absolute Acceleration Shock Spectra Versus “Modeled” Average Acceleration Shock Spectra for Test 4.

2DOF Tuned Deck Simulator - Test 5

Spring Beam Configuration: 2 Upper / 4 Lower

Test Weight on Deck Simulator: 1000 lbs

Total Weight on Anvil Table: 3889 lbs

MWSM Hammer Ht: 3.5 ft (Anvil Travel = 1.5 in)

10 of 10 Hammer Drops Used for Average.

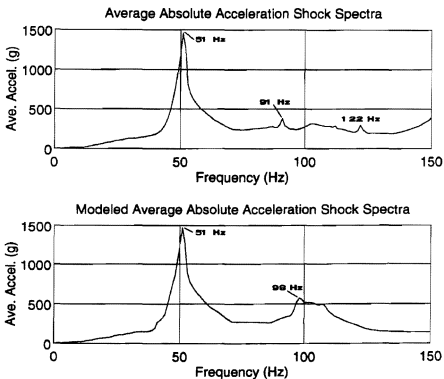

Figure 22. Average Absolute Acceleration Shock Spectra Versus “Modeled” Average Acceleration Shock Spectra for Test 5.

2DOF Tuned Deck Simulator - Test 6

Spring Beam Configuration: 2 Upper / 4 Lower

Test Weight on Deck Simulator: 500 lbs

Total Weight on Anvil Table: 3389 lbs

MWSM Hammer Ht: 1.75 ft (Anvil Travel = 3 in)

9 of 10 Hammer Drops Used for Average.

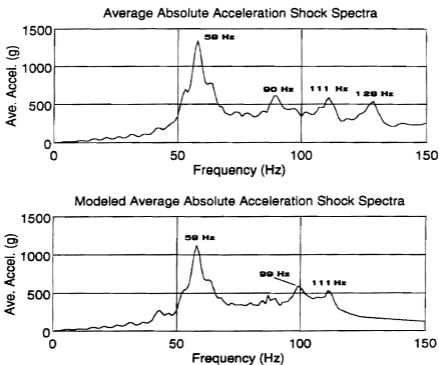

Figure 23. Average Absolute Acceleration Shock Spectra Versus “Modeled” Average Acceleration Shock Spectra for Test 6.

APPENDIX B: TABLES

Appendix B.1: Phase II Test Schedule

TABLE 1. PHASE II TEST SCHEDULE FOR 2DOF-TDS ON MWSM

<i>Test Number</i>	<i>Test Weight on 2DOF-TDS</i>	<i>Spring Beam Configuration</i>	<i>Height of Hammer Drop</i>	<i>Anvil Table Travel (in)</i>
1	500	3 upper/4 lower	3	3
2	1000	3/4	3.5	1.5
3	1500	3/4	4.5	1.5
Remove Center Spring Beam From Upper Tier				
4	1500	2/4	2.25	3
5	1000	2/4	3.5	1.5
6	500	2/4	1.75	3

Appendix B.2: Results of Test #1

TABLE 2. TEST 1: INITIAL CONDITIONS

<i>Weight on 2DOF Tuned Deck Simulator</i>	500 lbs
<i>Total Weight on Anvil Table</i>	3494 lbs
<i>Spring Beam Configuration</i>	3 upper / 4 lower
<i>MWSM Hammer Height</i>	3 ft
<i>Anvil Table Travel Limit</i>	3 in

TABLE 3. TEST 1: ABSOLUTE ACCELERATION SHOCK SPECTRAL PEAK FREQUENCIES

	<i>1st Peak</i>	<i>2nd Peak</i>	<i>3rd Peak</i>
<i>Graphical Estimate before Averaging (10 of 10 Drops)</i>	63 Hz	102 Hz	-
<i>Actual Average (10 of 10 Drops)</i>	64 Hz	-	-
<i>Modeled Average (10 of 10 Drops)</i>	64 Hz	114 Hz	-
<i>System Natural Frequencies from Mathcad® Worksheet</i>	62 Hz	115.6 Hz	-

Appendix B.3: Results of Test #2

TABLE 4. TEST 2: INITIAL CONDITIONS

<i>Weight on 2DOF Tuned Deck Simulator</i>	1000 lbs
<i>Total Weight on Anvil Table</i>	3994 lbs
<i>Spring Beam Configuration</i>	3 upper / 4 lower
<i>MWSM Hammer Height</i>	3.5 ft
<i>Anvil Table Travel Limit</i>	1.5 in

TABLE 5. TEST 2: ABSOLUTE ACCELERATION SHOCK SPECTRAL PEAK FREQUENCIES

	<i>1st Peak</i>	<i>2nd Peak</i>	<i>3rd Peak</i>
<i>Graphical Estimate before Averaging (8 of 10 Drops)</i>	56 Hz	98 Hz	110 Hz
<i>Actual Average (8 of 10 Drops)</i>	56 Hz	99 Hz	-
<i>Modeled Average (8 of 10 Drops)</i>	55 Hz	109 Hz	-
<i>System Natural Frequencies from Mathcad[®] Worksheet</i>	56.1 Hz	111.3 Hz	-

Appendix B.4: Results of Test #3

TABLE 6. TEST 3: INITIAL CONDITIONS

<i>Weight on 2DOF Tuned Deck Simulator</i>	1500 lbs
<i>Total Weight on Anvil Table</i>	4494 lbs
<i>Spring Beam Configuration</i>	3 upper / 4 lower
<i>MWSM Hammer Height</i>	4.5 ft
<i>Anvil Table Travel Limit</i>	1.5 in

TABLE 7. TEST 3: ABSOLUTE ACCELERATION SHOCK SPECTRAL PEAK FREQUENCIES

	<i>1st Peak</i>	<i>2nd Peak</i>	<i>3rd Peak</i>
<i>Graphical Estimate before Averaging (9 of 10 Drops)</i>	51 Hz	101 Hz	134 Hz
<i>Actual Average (9 of 10 Drops)</i>	51 Hz	101 Hz	135 Hz
<i>Modeled Average (9 of 10 Drops)</i>	51 Hz	109 Hz	-
<i>System Natural Frequencies from Mathcad® Worksheet</i>	51.9 Hz	109.1 Hz	-

Appendix B.5: Results of Test #4

TABLE 8. TEST 4: INITIAL CONDITIONS

<i>Weight on 2DOF Tuned Deck Simulator</i>	1500 lbs
<i>Total Weight on Anvil Table</i>	4389 lbs
<i>Spring Beam Configuration</i>	2 upper / 4 lower
<i>MWSM Hammer Height</i>	2.25 ft
<i>Anvil Table Travel Limit</i>	3 in

TABLE 9. TEST 4: ABSOLUTE ACCELERATION SHOCK SPECTRAL PEAK FREQUENCIES

	<i>1st Peak</i>	<i>2nd Peak</i>	<i>3rd Peak</i>
<i>Graphical Estimate before Averaging (9 of 10 Drops)</i>	44 Hz	88 Hz	107 Hz
<i>Actual Average (9 of 10 Drops)</i>	43 Hz	89 Hz	-
<i>Modeled Average (9 of 10 Drops)</i>	43 Hz	-	-
<i>System Natural Frequencies from Mathcad® Worksheet</i>	46.6 Hz	101.7 Hz	-

Appendix B.6: Results of Test #5

TABLE 10. TEST 5: INITIAL CONDITIONS

<i>Weight on 2DOF Tuned Deck Simulator</i>	1000 lbs
<i>Total Weight on Anvil Table</i>	3889 lbs
<i>Spring Beam Configuration</i>	2 upper / 4 lower
<i>MWSM Hammer Height</i>	3.5 ft
<i>Anvil Table Travel Limit</i>	1.5 in

TABLE 11. TEST 5: ABSOLUTE ACCELERATION SHOCK SPECTRAL PEAK FREQUENCIES

	<i>1st Peak</i>	<i>2nd Peak</i>	<i>3rd Peak</i>
<i>Graphical Estimate before Averaging (10 of 10 Drops)</i>	51 Hz	91 Hz	122 Hz
<i>Actual Average (10 of 10 Drops)</i>	51 Hz	91 Hz	122 Hz
<i>Modeled Average (10 of 10 Drops)</i>	51 Hz	98 Hz	-
<i>System Natural Frequencies from Mathcad® Worksheet</i>	51 Hz	102.9 Hz	-

Appendix B.7: Results of Test #6

TABLE 12. TEST 6: INITIAL CONDITIONS

<i>Weight on 2DOF Tuned Deck Simulator</i>	500 lbs
<i>Total Weight on Anvil Table</i>	3389 lbs
<i>Spring Beam Configuration</i>	2 upper / 4 lower
<i>MWSM Hammer Height</i>	1.75 ft
<i>Anvil Table Travel Limit</i>	3 in

TABLE 13. TEST 6: ABSOLUTE ACCELERATION SHOCK SPECTRAL PEAK FREQUENCIES

	<i>1st Peak</i>	<i>2nd Peak</i>	<i>3rd Peak</i>
<i>Graphical Estimate before Averaging (9 of 10 Drops)</i>	58 Hz	90 Hz	111 Hz
<i>Actual Average (9 of 10 Drops)</i>	58 Hz	90 Hz	111 Hz
<i>Modeled Average (9 of 10 Drops)</i>	58 Hz	99 Hz	111 Hz
<i>System Natural Frequencies from Mathcad® Worksheet</i>	57.7 Hz	105.4 Hz	-

Appendix B.8: Proposed Addendum to MIL-S-901D

TABLE 14. FOR INITIAL SPECTRAL PEAK BETWEEN 45 - 55 HZ AND SECOND PEAK BETWEEN 90 -100 HZ

<i>Total Weight on Anvil Table (pounds)</i>	<i>Spring Beam Configuration (upper/lower)</i>	<i>Height of Hammer Drop (feet)</i>	<i>Anvil Table Travel (inches)</i>
3900	2 / 4	3.5	1.5
4400	2 / 4	2.25	3
4500	3 / 4	4.5	1.5

TABLE 15. FOR INITIAL SPECTRAL PEAK BETWEEN 55 - 65 HZ AND SECOND PEAK BETWEEN 90 -100 HZ

<i>Total Weight on Anvil Table (pounds)</i>	<i>Spring Beam Configuration (upper/lower)</i>	<i>Height of Hammer Drop (feet)</i>	<i>Anvil Table Travel (inches)</i>
3400	2 / 4	1.75	3
3500	3 / 4	3	3
4000	3 / 4	3.5	1.5

NOTES:

1. Group I consists of two blows with the equipment mounted on the 2DOF Tuned Deck Simulator. The equipment shall be operated in its normal mode for the first blow and in its alternate mode for the second blow.
2. Group II consists of two blows with the equipment mounted on the Standard Inclined Fixture atop the 2DOF-TDS. The equipment shall be operated in its normal mode for the first blow and in its alternate mode for the second blow.
3. With 2DOF Tuned Deck Simulator in "2 / 4" Configuration, the "Total Weight on Anvil Table" equals 2570 plus weight of test item in pounds.

4. With 2DOF Tuned Deck Simulator in "3 / 4" Configuration, the "Total Weight on Anvil Table" equals 2675 plus weight of test item in pounds.
5. Include the weight of the Standard Incline Fixture (715 pounds) in the "Total Weight on Anvil Table" for all Group II blocks.

APPENDIX C: MATLAB® PROGRAMS AND MATHCAD® WORKSHEET

Appendix C.1: Model APPC1.M

```
%THE FOLLOWING MATLAB PROGRAM CALCULATES THE ABSOLUTE ACCELERATION  
%SHOCK SPECTRA FOR TEST 4 BLOW 7 GIVEN ABSOLUTE ACCELERATION DATA  
% (FROM ACCELEROMETER CHANNEL 5) OVER A ONE SECOND TIME DURATION  
% (CONTAINING 2048 DATA SAMPLES).  
  
%  
%  
t=linspace(0,1,2048); % Time Interval of 1 second containing 2048 data points.  
load t4b1c5s7.asc  
accel1=accel1(:);  
accel1=t4b1c5s7(1:2048); % Store absolute accel. data in array "accel1."  
  
%  
%Calculate the Absolute Acceleration Shock Spectra.  
%  
NF=150; % Number of Frequencies  
DF=1; % Frequency Increment  
SF=1; % Start Frequency  
Freq=[SF:DF:NF]; % Frequency Vector  
wn=2*pi*Freq; % Convert Hz to radians per second.  
F=[0,-1]; % State Space Matrices  
GG=[1,0];  
H=[-1];  
for i=1:NF % Step thru natural frequencies.  
E=[0,1,-(wn(i)^2),0];  
GG=[wn(i)^2,0];  
[yspec1]=isim(E,F,GG,H,accel1,t); % Computes relative accel.  
xspec1 = yspec1 + accel1; % Computes absolute accel. of single  
 % DOF system.  
maxspec1(i)=max(abs(xspec1)); % Stores largest value of absolute  
 % accel. computed at each natural  
 % frequency.  
end  
figure(1)  
subplot(311),axis('off')  
text(0.1,1,'MWSM 2DOF Tuned Deck Simulator - Test 4 Blow 7')  
text(0.1,0.6,'Spring Beam Configuration: 2 Upper / 4 Lower')  
text(0.1,0.4,'Test Weight on Deck Simulator: 1500 lbs')  
text(0.1,0.2,'Total Weight on Anvil Table: 4389 lbs')  
text(0.1,0.0,'MWSM Hammer Ht: 2.25 ft (Anvil Travel = 3 in)')  
subplot(312),plot(t,accel1),grid  
title('Acceleration Time History (Channel 5)')  
xlabel('Time (sec)')  
ylabel('Accel. (g)')
```

```
axis([0 1 -80 80])
subplot(313),plot(Freq,maxspec1),grid
title('Absolute Acceleration Shock Spectra')
xlabel('Frequency (Hz)')
ylabel('Accel. (g)')
axis([0 150 0 800])
set(1,'paperpos',[1.25 2 6 8])
print
freq=Freq;
cd ..
```

Appendix C.2: Model APPC2.M

```
%THE FOLLOWING PROGRAM CALCULATES THE AVERAGE ABSOLUTE
%ACCELERATION SHOCK SPECTRA AND THE 2DOF TUNED DECK SIMULATOR
%MODEL'S AVERAGE ABSOLUTE ACCELERATION SHOCK SPECTRA FOR TEST
%ONE OF PHASE II CHARACTERIZATION TESTING. THE ORIGINAL VERSION
%OF THIS MATLAB CODE WAS PROVIDED BY COX (COX, 1993, PP. 109-112).

t=linspace(0,1,2048); % TIME INTERVAL OF 1 SECOND CONTAINING 2048 DATA
POINTS.

%
%LOAD=500; % LOAD = TEST LOAD (500, 1000 or 1500 LBS).
%nk1=3; % nk1 = NUMBER OF SPRING BEAMS (2 OR 3) IN UPPER TIER.
%nk2=4; % nk2 = NUMBER OF SPRING BEAMS IN LOWER TIER.

cd coxfile
load t1b2c5s1.asc % LOAD DATA FILES FOR 10 SAMPLES
load t1b2c5s2.asc
load t1b2c5s3.asc
load t1b2c5s4.asc
load t1b2c5s5.asc
load t1b2c5s6.asc
load t1b2c5s7.asc
load t1b2c5s8.asc
load t1b2c5s9.asc
load t1b2c5s0.asc
accel1=t1b2c5s1;
accel2=t1b2c5s2;
accel3=t1b2c5s3;
accel4=t1b2c5s4;
accel5=t1b2c5s5;
accel6=t1b2c5s6;
accel7=t1b2c5s7;
accel8=t1b2c5s8;
accel9=t1b2c5s9;
accel10=t1b2c5s0;

%
accel1=accel1(:);
accel2=accel2(:);
accel3=accel3(:);
accel4=accel4(:);
accel5=accel5(:);
accel6=accel6(:);
accel7=accel7(:);
accel8=accel8(:);
accel9=accel9(:);
accel10=accel10(:);

%
%
% THIS SUBROUTINE INPUTS ACCELERATION (g's) and TIME (SECONDS)
%FROM 2DOF TUNED DECK SIMULATOR TEST BLOWS WITH UP TO TEN SAMPLES
%INTO THE FUNCTION "SPECTRA.M" IN ORDER TO OBTAIN THE AVERAGE
%ABSOLUTE ACCELERATION SHOCK SPECTRA.
```

```

%
%
%Output Variable: maxspec=largest value of absolute acceleration computed at each natural
frequency
%
%
%Calculate the Shock Spectra for Samples 1 through 10.
%
    cd ..
    maxspec1=spectra(accel1,t);
    maxspec2=spectra(accel2,t);
    maxspec3=spectra(accel3,t);
    maxspec4=spectra(accel4,t);
    maxspec5=spectra(accel5,t);
    maxspec6=spectra(accel6,t);
    maxspec7=spectra(accel7,t);
    maxspec8=spectra(accel8,t);
    maxspec9=spectra(accel9,t);
    maxspec10=spectra(accel10,t);
%
    Freq=[1:1:150]; % FREQUENCY BAND OF INTEREST
%
%Calculate the Average Absolute Acceleration Shock Spectra.
%
    avmaxspec=(maxspec1+maxspec2+maxspec3+maxspec4+maxspec5+maxspec6+
maxspec7+maxspec8+maxspec9+maxspec10)/10;
%
%
%
    cd coxfile
    load t1b2c1s1.asc
    load t1b2c1s2.asc
    load t1b2c1s3.asc
    load t1b2c1s4.asc
    load t1b2c1s5.asc
    load t1b2c1s6.asc
    load t1b2c1s7.asc
    load t1b2c1s8.asc
    load t1b2c1s9.asc
    load t1b2c1s0.asc
    base1=t1b2c1s1;
    base2=t1b2c1s2;
    base3=t1b2c1s3;
    base4=t1b2c1s4;
    base5=t1b2c1s5;
    base6=t1b2c1s6;
    base7=t1b2c1s7;
    base8=t1b2c1s8;
    base9=t1b2c1s9;
    base10=t1b2c1s0;
%
    base1=base1(:);
    base2=base2(:);
    base3=base3(:);
    base4=base4(:);
    base5=base5(:);

```

```

base6=base6();
base7=base7();
base8=base8();
base9=base9();
base10=base10();

%
%THIS SUBROUTINE UTILIZES THE FUNCTION "MODEL.M" TO
%INPUT UP TO 10 SAMPLES OF ACCELEROMETER CHANNEL #1 DATA
%INTO THE 2DOF TUNED DECK SIMULATOR MODEL TO OBTAIN THE
%AVERAGE MODELED ABSOLUTE ACCELERATION SHOCK SPECTRA.
%
cd ..
[X1ACC1,modspec1]=model(base1,1,3,4,500);
[X1ACC2,modspec2]=model(base2,1,3,4,500);
[X1ACC3,modspec3]=model(base3,1,3,4,500);
[X1ACC4,modspec4]=model(base4,1,3,4,500);
[X1ACC5,modspec5]=model(base5,1,3,4,500);
[X1ACC6,modspec6]=model(base6,1,3,4,500);
[X1ACC7,modspec7]=model(base7,1,3,4,500);
[X1ACC8,modspec8]=model(base8,1,3,4,500);
[X1ACC9,modspec9]=model(base9,1,3,4,500);
[X1ACC10,modspec10]=model(base10,1,3,4,500);

%
%Calculate the Model Average Absolute Acceleration Shock Spectra.
%
avmodspec=(modspec1+modspec2+modspec3+modspec4+modspec5+modspec6+
modspec7+modspec8+modspec9+modspec10)/10;

%
subplot(311),axis('off')
text(0.1,1,'2DOF Tuned Deck Simulator - Test 1')
text(0.1,0.8,'Spring Beam Configuration: 3 Upper / 4 Lower')
text(0.1,0.6,'Test Weight on Deck Simulator: 500 lbs')
text(0.1,0.4,'Total Weight on Anvil Table: 3494 lbs')
text(0.1,0.2,'MWSM Hammer Ht: 3 ft (Anvil Travel = 3 in)')
text(0.1,0.0,'10 of 10 Hammer Drops Used for Average.')
subplot(312),plot(Freq,avmaxspec),grid
title('Average Absolute Acceleration Shock Spectra')
xlabel('Frequency (Hz)')
ylabel('Ave. Accel. (g)')
subplot(313),plot(Freq,avmodspec),grid
title('Modeled Average Absolute Acceleration Shock Spectra')
xlabel('Frequency (Hz)')
ylabel('Ave. Accel. (g)')
set(1,'paperpos',[1.25 2 6 8])
print

```

Appendix C.2 (cont.)

```
function [maxspec]=spectra(accel,t)
NF= 50;           % NUMBER OF FREQUENCIES
DF=1;            % FREQUENCY INCREMENT
SF=1;           % START FREQUENCY
Freq=[SF:DF:NF]; % FREQUENCY VECTOR
wn=2*pi*Freq;
F=[0,-1];       % STATE SPACE MATRICES
GG=[1,0];
H=[-1];
for i=1:NF      % STEP THROUGH NATURAL FREQUENCIES.
    E=[0,1;-wn(i)^2,0];
    GG=[wn(i)^2,0];
    [yspec]=isim(E,F,GG,H,accel,t);
    xspec=yspec + accel;
    maxspec(i)=max(abs(xspec));
end
```

Appendix C.2 (cont.)

```

function [X1ACC,modspec]=model(base,t,nk1,nk2,LOAD)
%function [X1ACC,modspec]=model(base,t,nk1,nk2,LOAD)
%
%THIS PROGRAM INPUTS 1 SECOND OF ACCELEROMETER CHANNEL #1 DATA INTO
%THE 2DOF TUNED DECK SIMULATOR MODEL ONE SAMPLE AT A TIME TO OBTAIN
%THE AVERAGE MODELED ACCELERATION SHOCK SPECTRA.
%
%INPUT VARIABLES:
%   base=anvil table absolute acceleration (base excitation).
%   t=total sampling time period of 1 second duration during which 2048 data points were
%   obtained.
%
%USER DEFINED VARIABLES:
%   nk1=3;
%   nk2=4;
%   LOAD=500;
%
%   LOAD=weight (500,1000 or 1500 lbs) atop 2DOF fixture.
%   nk1=number of spring beams (2 or 3) in upper tier of fixture.
%   nk2=number of spring beams (3 or 4) in lower tier of fixture.
%
%OUTPUT VARIABLES: X1ACC=model absolute acceleration of mass M1.
%   MODSPEC=model absolute acceleration shock spectra.
%
%   Wt1=738+LOAD;      % Weight of Upper Tier in lbs in 3/4 Configuration
%   Wt2=1810;         % Weight of Lower Tier in lbs in 3/4 Configuration
%   Wt1=662+LOAD;     % Weight of Upper Tier in lbs in 2/4 Configuration
%   Wt2=1756;         % Weight of Lower Tier in lbs in 2/4 Configuration
%   kbeam=2.947e6;    % Stiffness per Beam in lbs/ft
%   k1=nk1*kbeam;     % Upper Tier Stiffness in lbs/ft
%   k2=nk2*kbeam;     % Lower Tier Stiffness in lbs/ft
%   zeta=.035;        % Critical Damping Factor
%   anvil1=base(:)*32.2; % Accelerometer Channel #1 Data in ft/sec^2
%   t=(:) ;           % Time in seconds
%
%Calculate the mass and mass ratio.
%   m1=Wt1/32.2 ;
%   m2=Wt2/32.2 ;
%   m=[m1,0,0,m2];
%   alpha=m1/m2;
%Calculate Tier Natural Frequencies.
%   w1=sqrt(k1/m1);
%   w2=sqrt(k2/m2);
%Calculate System Natural Frequencies.
%   var=sqrt((w1^2 + alpha*w1^2 + w2^2)^2 - (2*w1*w2)^2);
%   wn1=(1/sqrt(2))*sqrt(w1^2 + alpha*w1^2 + w2^2 - var);
%   wn2=(1/sqrt(2))*sqrt(w1^2 + alpha*w1^2 + w2^2 + var);
%Uncouple the equations.
%   u11=1;
%   u21=(k1 - wn1^2 * m1)/k1;
%   u12=1;
%   u22=(k1 - wn2^2 * m1)/k1;
%   U=[u11,u12;u21,u22];

```

```

%Determine the Modal Mass Matrix.
M=U'*m*U;
%Determine the Modal Stiffness Matrix.
k=[k1,-k1;-k1,k1+k2];
K=U'*k*U;
%Determine the Force Coefficients.
FC=(U'*[-m1;-m2]);
%Solve the Uncoupled Equations of Motion.
% {n1}=[m1*{ddot1}+2*zeta*wn1*{ndot1}+wn1^2*{n1}]=FC11*anvil1/M1
% {n2}=[m2*{ddot2}+2*zeta*wn2*{ndot2}+wn2^2*{n2}]=FC21*anvil1/M2
%
%State Space Matrix for Equation #1
A1=[0,1,-(wn1^2),-2*zeta*wn1];
B1=[0;FC(1:1)/M(1:1)];
C1=[1,0,0,1,-(wn1^2),-2*zeta*wn1];
D1=[0;0;FC(1:1)/M(1:1)];
[y1]=lsim(A1,B1,C1,D1,anvil1,t);
%State Space Matrix for Equation #2
A2=[0,1,-(wn2^2),-2*zeta*wn2];
B2=[0;FC(2:2)/M(4:4)];
C2=[1,0,0,1,-(wn2^2),-2*zeta*wn2];
D2=[0;0;FC(2:2)/M(4:4)];
[y2]=lsim(A2,B2,C2,D2,anvil1,t);
%
%Couple The Equations.
Y1ACC=u11*y1(:,3) + u12*y2(:,3);
X1ACC=(Y1ACC+anvil1)/32.2; % Absolute Acceleration in g's
%
%Calculate the Model Shock Spectra for Samples 1 through 10.
%
NF=150; % NUMBER OF FREQUENCIES
DF=1; % FREQUENCY INCREMENT
SF=1; % START FREQUENCY
Freq=[SF:DF:NF]; % FREQUENCY VECTOR
wn=2*pi*Freq;
F=[0;-1]; % STATE SPACE MATRICES
GG=[1,0];
H=[-1];
for i=1:NF
    E=[0,1,-(wn(i)^2),0];
    GG=[wn(i)^2,0];
    [yspec]=lsim(E,F,GG,H,X1ACC,t);
    xspec=xspec+X1ACC;
    modspec(i)=max(abs(xspec));
end

```

Appendix C.3: MATHCAD® Worksheet: System Natural Frequencies

A. SPRING STIFFNESS:

The spring stiffness is based on the following beam model:

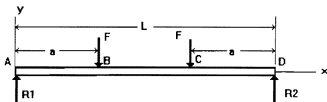

Supply the following Dimensions:

1) *Dimensions:*

	<u>Upper Tier</u>	<u>Lower Tier</u>
Length:	$L_1 = 50 \text{ in}$	$L_2 = 50 \text{ in}$
Load Application Point:	$a_1 = 13 \text{ in}$	$a_2 = 13 \text{ in}$
Area Moment of Inertia:	$I_1 = 11.3 \text{ in}^4$	$I_2 = 11.3 \text{ in}^4$
Young's Modulus:	$E = 30 \cdot 10^6 \text{ psi}$	$E = 30 \cdot 10^6 \text{ psi}$

2) *Stiffness:*

From the beam bending equation:
$$y_{AB} = \frac{F \cdot x}{6 \cdot EI} (x^2 + 3 \cdot a^2 - 3 \cdot L)$$

Let $x=a$ and $F=W/2$:
$$y_{AB} = \frac{W \cdot a^2}{12 \cdot EI} (4 \cdot a - 3 \cdot L)$$

Solving for the stiffness:
$$K = \frac{W}{y_{AB}} = \frac{12 \cdot E \cdot I}{a^2 \cdot (3 \cdot L - 4 \cdot a)} \quad \frac{\text{lb}}{\text{in}}$$

For:

	<u>Upper Tier</u>	<u>Lower Tier</u>
(Convert inches to feet)	$KB_1 = \frac{12 \cdot E \cdot I_1}{a_1^2 \cdot (3 \cdot L_1 - 4 \cdot a_1)} \cdot 12$	$KB_2 = \frac{12 \cdot E \cdot I_2}{a_2^2 \cdot (3 \cdot L_2 - 4 \cdot a_2)} \cdot 12$

(per beam)	$KB_1 = 2.947 \cdot 10^6 \frac{\text{lb}}{\text{ft}}$	$KB_2 = 2.947 \cdot 10^6 \frac{\text{lb}}{\text{ft}}$
------------	---	---

	<u>Upper Tier</u>	<u>Lower Tier</u>
Input Number of Beams Per Tier:	Beams ₁ = 3	Beams ₂ = 4
	$K_1 = KB_1 \cdot \text{Beams}_1$	$K_2 = KB_2 \cdot \text{Beams}_2$
Tier Stiffness:	$K_1 = 8.842 \cdot 10^6 \frac{\text{lb}}{\text{ft}}$	$K_2 = 1.179 \cdot 10^7 \frac{\text{lb}}{\text{ft}}$

B. SYSTEM MASSES: (Includes Effective Spring Mass)

Upper Tier Weight: (W₁)

$$W_1 = 1238$$

$$M_1 = \frac{W_1}{32.2}$$

$$M_1 = 38.447 \frac{\text{lb} \cdot \text{ft}}{\text{sec}^2}$$

Intermediate Weight: (W₂)

$$W_2 = 1810$$

$$M_2 = \frac{W_2}{32.2}$$

$$M_2 = 56.211 \frac{\text{lb} \cdot \text{ft}}{\text{sec}^2}$$

Anvil Table Weight: (W₃)

$$W_3 = 4634$$

$$M_3 = \frac{W_3}{32.2}$$

$$M_3 = 143.913 \frac{\text{lb} \cdot \text{ft}}{\text{sec}^2}$$

C. TIER NATURAL FREQUENCIES:

Upper Tier

$$F_1 = \frac{1}{2 \cdot \pi} \sqrt{\frac{K_1}{M_1}}$$

$$F_1 = 76.326 \text{ Hz}$$

Lower Tier

$$F_2 = \frac{1}{2 \cdot \pi} \sqrt{\frac{K_2}{M_2}}$$

$$F_2 = 72.889 \text{ Hz}$$

D. System Natural Frequencies:

Defining B as:

$$B = \frac{K_1}{M_1} + \frac{K_2}{M_3} + \frac{K_1 + K_2}{M_2}$$

$$f_{n1} = \frac{1}{2 \cdot \pi} \sqrt{\frac{1}{2} \left[B - \sqrt{B^2 - \frac{4 K_1 K_2}{M_1 \cdot M_2 \cdot M_3} (M_1 + M_2 + M_3)} \right]}$$

First Frequency: $f_{n1} = 61.979 \text{ Hz}$

$$f_{n2} = \frac{1}{2 \cdot \pi} \sqrt{\frac{1}{2} \left[B + \sqrt{B^2 - \frac{4 K_1 K_2}{M_1 \cdot M_2 \cdot M_3} (M_1 + M_2 + M_3)} \right]}$$

Second Frequency: $f_{n2} = 115.572 \text{ Hz}$

LIST OF REFERENCES

Anderson, C.A., *A Commanding Officer's Perspective of Ship Shock Trials, Proceedings of the 58th Shock and Vibration Symposium*, Vol. II, pp.35-40, October 1987.

Clements, E.W., *Shipboard Shock and Navy Devices for its Simulation*, Naval Research Laboratory Report 7396, July 1972.

Corbell, R.D., *Shock Qualification of Combat Systems Equipment Using Tuned Mounting Fixtures on the U.S. Navy's Mediumweight Shock Machine*, Master's Thesis, Naval Postgraduate School, Monterey, California, 1992.

Cox, D.M., *Design of a Multi-DOF Tuned Mounting Fixture for the Navy's Mediumweight Shock Machine*, Master's Thesis, Naval Postgraduate School, Monterey, California, June 1993.

Horton, K.J., *Modal Tests of Decks of DDG-51 Class Combat Systems Equipment Rooms*, Bath Iron Works Corporation, Bath, Maine, September 1993.

Martin, G., "Environmentalists Oppose Navy Tests," *San Francisco Chronicle*, p. 13, 14 February 1994.

Messina, G.J., *MWSM Characterization*, Naval Undersea Warfare Center, New London, Connecticut, June 1993.

Military Specification, MIL-S-901D, *Shock Tests, High Impact; Shipboard Machinery, Equipment and Systems, Requirements for*, March 1989.

Naval Sea Systems Command, Department of the Navy, *NAVSEA Instruction 9072.1A: Shock Hardening of Surface Ships*, November 1989.

Office of the Chief of Naval Operations, Department of the Navy, *OPNAV Instruction 9070: Survivability Policy for Surface Ships of the U.S. Navy*, September 1988.

Ogata, K., *System Dynamics*, (2nd ed.), Prentice Hall Inc., 1992.

INITIAL DISTRIBUTION LIST

		Copies
1.	Defense Technical Information Center Cameron Station Alexandria, VA 22304-6145	2
2.	Library, Code 52 Naval Postgraduate School Monterey, CA 93943-5101	2
3.	Professor Y. S. Shin, Code ME/Sg Department of Mechanical Engineering Naval Postgraduate School Monterey, CA 93943	2
4.	Department Chairman, Code ME Department of Mechanical Engineering Naval Postgraduate School Monterey, CA 93943	1
5.	Naval Engineering, Code 34 Naval Postgraduate School Monterey, CA 93943	1
6.	Mr. Mark McLean, Code 03K21 Naval Sea Systems Command 2531 Jefferson Davis Highway Arlington, VA. 22242-5160	2
7.	Mr. Edward Marsh, Code 421 Naval Undersea Warfare Center - New London New London, CONN. 06320-5594	1
8.	Mr. Steven Schecter Senior Scientist/Engineer Mechanical Development Department Surface Ships Systems Division P.O. Box 3310 Fullerton, CA 92634-3310	1

9. Mr. Frederick Costanzo 1
Naval Surface Warfare Center
Underwater Explosion Research Division
Norfolk Naval Shipyard, Bldg. 369
Portsmouth, VA 23709
10. Mr. James Murray 1
Naval Surface Warfare Center
Underwater Explosion Research Division
Norfolk Naval Shipyard, Bldg. 369
Portsmouth, VA 23709
11. Mr. Gerald Messina, Code 4211 1
Naval Undersea Warfare Center - New London
New London, CONN. 06320-5594
12. Mr. Bill Briggs, Code 4212 1
Naval Undersea Warfare Center - Newport
1176 Howell Street
Newport, RI. 02840

DUDLEY KNOX LIBRARY
NAVAL POSTGRADUATE SCHOOL
MONTEREY CA 93943-5101



GAYLORD 2

DUDLEY KNOX LIBRARY



3 2768 00019588 7