



Calhoun: The NPS Institutional Archive
DSpace Repository

NPS Scholarship

Theses

2003-03

Factors affecting organizational performance
NRD San Diego FY1997-2000 : a systems analysis

Nafarrete, Romuel B.

Monterey, California. Naval Postgraduate School

<https://hdl.handle.net/10945/1081>

This publication is a work of the U.S. Government as defined in Title 17, United States Code, Section 101. Copyright protection is not available for this work in the United States.

Downloaded from NPS Archive: Calhoun



Calhoun is the Naval Postgraduate School's public access digital repository for research materials and institutional publications created by the NPS community. Calhoun is named for Professor of Mathematics Guy K. Calhoun, NPS's first appointed -- and published -- scholarly author.

Dudley Knox Library / Naval Postgraduate School
411 Dyer Road / 1 University Circle
Monterey, California USA 93943

<http://www.nps.edu/library>

NAVAL POSTGRADUATE SCHOOL Monterey, California



THESIS

**FACTORS AFFECTING ORGANIZATIONAL
PERFORMANCE NRD SAN DIEGO FY1997-2000: A
SYSTEMS ANALYSIS**

by

Romuel B. Nafarrete

March 2003

Principal Advisor:
Associate Advisor:

Cary A. Simon
William D. Hatch II

Approved for public release; distribution is unlimited

THIS PAGE INTENTIONALLY LEFT BLANK

REPORT DOCUMENTATION PAGE			Form Approved OMB No. 0704-0188	
Public reporting burden for this collection of information is estimated to average 1 hour per response, including the time for reviewing instruction, searching existing data sources, gathering and maintaining the data needed, and completing and reviewing the collection of information. Send comments regarding this burden estimate or any other aspect of this collection of information, including suggestions for reducing this burden, to Washington headquarters Services, Directorate for Information Operations and Reports, 1215 Jefferson Davis Highway, Suite 1204, Arlington, VA 22202-4302, and to the Office of Management and Budget, Paperwork Reduction Project (0704-0188) Washington DC 20503.				
1. AGENCY USE ONLY (Leave blank)	2. REPORT DATE March 2003	3. REPORT TYPE AND DATES COVERED Master's Thesis		
4. TITLE AND SUBTITLE: Factors Affecting Organizational Performance NRD San Diego FY1997-2000: A Systems Analysis			5. FUNDING NUMBERS	
6. AUTHOR(S) Romuel B. Nafarrete				
7. PERFORMING ORGANIZATION NAME(S) AND ADDRESS(ES) Naval Postgraduate School Monterey, CA 93943-5000			8. PERFORMING ORGANIZATION REPORT NUMBER	
9. SPONSORING /MONITORING AGENCY NAME(S) AND ADDRESS(ES) N/A			10. SPONSORING/MONITORING AGENCY REPORT NUMBER	
11. SUPPLEMENTARY NOTES The views expressed in this thesis are those of the author and do not reflect the official policy or position of the Department of Defense or the U.S. Government.				
12a. DISTRIBUTION / AVAILABILITY STATEMENT Approved for public release; distribution is unlimited			12b. DISTRIBUTION CODE	
13. ABSTRACT (maximum 200 words) This thesis is a descriptive, comparative organizational analysis of Navy Recruiting District, San Diego during two time periods: Fiscal years 1997-1998 and 1999-2000. The purpose of this study was to determine those factors affecting organizational performance in the primary area of Enlisted Recruiting production of the district in both time periods using a systems analysis. Based on model comparisons, document reviews, interviews, and personal communications with the leaders, supervisors and recruiters of NRD San Diego, analysis indicates that the district of FY97-98 was ill-equipped in strategy, resources and processes to perform effectively in a more demanding environment. The heightened goal requirements and increased number of recruiting personnel placed on all recruiting districts between 1997 and 1998 exposed NRD San Diego's system weaknesses, resulting in lower indicators of successful performance. The FY99-00 district appeared to handle change better including higher indicators of successful performance such as process improvements, energetic leadership, flattened communication and work flow structures and a well-defined direction. The district's enlisted production performance improved from 1997 to 2000.				
14. SUBJECT TERMS Recruiting, Accession, Delayed Entry, End Strength, Systems, Culture, Leadership and Processes			15. NUMBER OF PAGES 161	
			16. PRICE CODE	
17. SECURITY CLASSIFICATION OF REPORT Unclassified	18. SECURITY CLASSIFICATION OF THIS PAGE Unclassified	19. SECURITY CLASSIFICATION OF ABSTRACT Unclassified	20. LIMITATION OF ABSTRACT UL	

NSN 7540-01-280-5500

Standard Form 298 (Rev. 2-89)
Prescribed by ANSI Std. Z39-18

THIS PAGE INTENTIONALLY LEFT BLANK

Approved for public release; distribution is unlimited

**FACTORS AFFECTING ORGANIZATIONAL PERFORMANCE NRD SAN DIEGO
FY1997-2000: A SYSTEMS ANALYSIS**

Romuel B. Nafarrete
Lieutenant Commander, United States Navy
B.S., United States Naval Academy 1991
M.S., National University 1996

Submitted in partial fulfillment of the
requirements for the degree of

MASTER OF SCIENCE IN MANAGEMENT

from the

**NAVAL POSTGRADUATE SCHOOL
March 2003**

Author: Romuel B. Nafarrete

Approved by: Cary A. Simon
Principal Advisor

William D. Hatch II
Associate Advisor

Douglas A. Brook, Ph.D.
Dean, Graduate School of Business and Public Policy

THIS PAGE INTENTIONALLY LEFT BLANK

ABSTRACT

This thesis is a descriptive, comparative organizational analysis of Navy Recruiting District, San Diego during two time periods: Fiscal years 1997-1998 and 1999-2000. The purpose of this study was to determine those factors affecting organizational performance in the primary area of Enlisted Recruiting production of the district in both time periods using a systems analysis. Based on model comparisons, document reviews, interviews, and personal communications with the leaders, supervisors and recruiters of NRD San Diego, analysis indicates that the district of FY97-98 was ill-equipped in strategy, resources and processes to perform effectively in a more demanding environment. The heightened goal requirements and increased number of recruiting personnel placed on all recruiting districts between 1997 and 1998 exposed NRD San Diego's system weaknesses, resulting in lower indicators of successful performance. The FY99-00 district appeared to handle change better including higher indicators of successful performance such as process improvements, energetic leadership, flattened communication and work flow structures and a well-defined direction. The district's enlisted production performance improved from 1997 to 2000.

THIS PAGE INTENTIONALLY LEFT BLANK

TABLE OF CONTENTS

I.	INTRODUCTION.....	1
A.	OVERVIEW	1
B.	METHODOLOGY	2
C.	BENEFIT OF THE STUDY	2
D.	SCOPE AND LIMITATIONS.....	2
E.	ORGANIZATION OF THE THESIS.....	3
II.	LITERATURE REVIEW	5
A.	SYSTEMS THEORY	5
B.	THE BASIC SYSTEMS MODEL	7
1.	Inputs	9
a.	Context.....	9
b.	Key Success Factors.....	9
c.	System Direction	10
2.	Design Factors	10
a.	Tasks/Jobs.....	10
b.	Technology.....	10
c.	Structure	11
d.	People	11
e.	Process/Subsystems.....	11
3.	Culture	12
4.	Outputs and Outcomes	14
C.	ANALYSIS OF SYSTEM FIT.....	14
D.	GENERAL OVERVIEW OF A RECRUITING DISTRICT	15
1.	Mission	17
2.	Organization.....	17
a.	Executive Leadership.....	17
b.	Support Departments	17
c.	Enlisted Programs Department.....	19
3.	Major Processes and Subsystems	30
a.	Goals and Goaling.....	30
b.	DEP Management	32
c.	Training	33
d.	Administration	33
e.	Prospect to Contract to Recruit.....	34
f.	Education Verification.....	36
g.	Waiver Processing.....	37
III.	MODEL RESULTS	39
A.	DATA REVIEW.....	39
B.	SYSTEMS MODELS COMPARISON: NRD SAN DIEGO (1997-1998) AND (1999-2000).....	39

1.	Inputs	39
a.	Context and Environment	39
b.	Key Success Factors	45
c.	System Direction	55
2.	Design Factors	58
a.	Tasks	58
b.	Technology	59
c.	Structure	64
d.	People	72
e.	Processes/Subsystems	73
3.	Culture	100
a.	Norms and Assumptions	100
b.	Leadership	110
4.	Outputs and Outcomes	112
C.	ANALYSIS OF FIT	113
IV.	CONCLUSIONS AND RECOMMENDATIONS	127
A.	CONCLUSIONS	127
1.	Similarities	127
2.	Differences	128
B.	RECOMMENDATIONS	131
	APPENDIX A. LIST OF INTERVIEWEES, PERSONAL COMMUNICATIONS AND CONVERSATIONS	133
	APPENDIX B. INTERVIEW PROTOCOL	135
	APPENDIX C. SAMPLE GOALING LETTER 99-00	137
	APPENDIX D. (EXCERPT FROM) SAMPLE EPO PASSDOWN LOG 99-00	139
	LIST OF REFERENCES	141
	INITIAL DISTRIBUTION LIST	143

LIST OF FIGURES

Figure 2.1.	Organizational Systems Framework.....	8
Figure 2.2.	Typical Command Organization.....	19
Figure 2.3.	Typical Enlisted Programs Department.....	20
Figure 2.4.	Prospect to Contract to Accession.....	36
Figure 3.1.	NRD SD Zones.....	65
Figure 3.2.	Enlisted Production Organizational Structure 97-98.....	69
Figure 3.3.	Enlisted Production Organizational Structure 99-00.....	72
Figure 3.4.	Personnel Assignment Process 97-98.....	75
Figure 3.5.	Personnel Assignment Process 99-00.....	76
Figure 3.6.	Recruiter Assignment Process 97-00.....	77
Figure 3.7.	Evaluation/Fitness Report Process 97-98.....	81
Figure 3.8.	Evaluation/Fitness Report Process 99-00.....	82
Figure 3.9.	Administrative Communication Flow 97-98.....	86
Figure 3.10.	Production Communications Flow 97-98.....	87
Figure 3.11.	Administrative Communication Flow 99-00.....	88
Figure 3.12.	Production Communication Flows 99-00.....	89
Figure 3.13.	Accession Communication Flows 99-00.....	90
Figure 3.14.	Standard DEP-in and Frontloading DEP-in.....	94
Figure 3.15.	Education Verification Process 97-98.....	95
Figure 3.16.	Education Verification Process 99-00.....	96
Figure 3.17.	DAR Routing Process 97-98.....	97
Figure 3.18.	DAR Routing Process 99-00.....	98
Figure 3.19.	LEADS Marketing Process 97-98.....	99
Figure 3.20.	LEADS Tele-Marketing Process 99-00.....	100
Figure 3.21.	Systems Model NRD San Diego FY1997-1998.....	114
Figure 3.22.	Systems Model NRD San Diego FY1999-2000.....	115
Figure 3.23.	Comparison of Checklist of Fit Analyses: NRD San Diego, 1997-1998 and 1999-2000.....	126

THIS PAGE INTENTIONALLY LEFT BLANK

LIST OF TABLES

Table 1.0.	NCO/Accession Attainment Summary NRD San Diego: 1997-2000.	2
Table 2.0	Harrison's Checklist of Important Fits.....	16

THIS PAGE INTENTIONALLY LEFT BLANK

LIST OF ACRONYMS

AEPO:	Assistant EPO
ASVAB:	Armed Services Vocational Aptitude Battery
AWOL:	Absent Without Leave
BA:	Budget Assistant
BEERS:	Basic Enlistment Entry Requirements
BOM:	Beginning of Month
BOY:	Beginning of Year
CA:	Chief Administrator
CMC:	Command Master Chief
CNRC:	Commander, Navy Recruiting Command
CNRW:	Commander, Navy Region West
CR:	Chief Recruiter
CRF:	Career Recruiting Force
DAR:	Delayed Entry Program Activity Report
DEP:	Delayed Entry Program
DEPCO:	Delayed Entry Program Coordinator
DEPper:	Member of the Delayed Entry Program
EDSPEC:	Educational Specialist
EDVER:	Educational Verification
EOM:	End of Month
EPDS:	Enlisted Processing Division Supervisor
EPO YN:	EPO Yeoman
EPO:	Enlisted Programs Officer
HP3:	High Predictor Performance Profile, Non-Diploma, Non-High School Graduate
HR:	Human Resources
IRC:	Interservice Recruiting Council
LDO:	Limited Duty Officer
LEADS:	Local Effective Accession Data
LSO:	Logistics Support Officer
LTCS:	LEADS Tracking Center Supervisor
MEPS:	Military Entrance Processing Station
MLPO:	Military Entrance Processing Station Liaison Petty Officer

MOP: Marketing Operations Plan

 NCO: New Contract Objective, also stands for New Contract
 NORU: Navy Recruiting Orientation Unit
 NPRDC: Naval Personnel Research and Development Center
 NRC: Navy Recruiting Council
 NRD: Navy Recruiting District
 NRD SD: Navy Recruiting District San Diego
 NRS: Navy Recruiting Station

 OPO: Officer Programs Officer

 PDC: Personally Developed Contract
 PDL: Passdown Log
 PN: Personnelman
 PQS: Personnel Qualification Standard
 PRIDE: Personalized Recruiting for Immediate and Delayed Entry

 QNE: Qualified, Not Enlisted (applicant)

 RAD: Recruiting Aid Device
 RDAC: Recruiting District Advisory Council
 RINC: Recruiter-In-Charge
 ROY: Recruiter of the Year
 RQAT: Recruiter Quality Assurance Team
 RQS: Recruiter Qualification Standards
 RTC: Recruit Training Command
 RTO: Refuse to Obligate

 STEAM: Standard Territory Evaluation Analysis Market

 YN: Yeoman

 ZS: Zone Supervisor

ACKNOWLEDGMENTS

First and foremost the author would like to thank his beautiful wife for putting up with all the incessant typing! The author also thanks the men and women of Navy Recruiting District, San Diego for their time and honesty, especially Master Chief Alice Ervine, Chief Mike McFerron, Commander Ray Wynne, Commander Jon Mosier, Lieutenant Commander Leo Alba, Mr. Steve Quebedeaux, Petty Officer Tyree O'Neal, Petty Officer Mark Williams, Ms. Sue Lesage, Ms. Norma Zucconi, Chief Tyrone Parker, Chief Ricky Adams, Chief Doug Graffious, Chief Tim Stewart, Chief Jay Smith, Chief Jay Woods, Chief Frank Camarillo, Petty Officer Ernie Caballero, Petty Officer Ray King, Petty Officer Anthony Jordan, and Chief Vic Belmares.

The author would like to acknowledge the immeasurable contributions made by the Commander, Navy Recruiting Command statistical team, most notably, Mr. John Noble, Ms. Sheila Johnson and Ms. Doretha McCloud.

The author would also like to thank Professor Cary Simon for his patience and rich instruction in Systems Theory; and CDR Bill Hatch for his tremendous insight into the manpower processes.

THIS PAGE INTENTIONALLY LEFT BLANK

I. INTRODUCTION

A. OVERVIEW

Navy Recruiting Command is organized into 31 Navy Recruiting Districts (NRD's) operating in four Regions. Each NRD is goaled, manned, budgeted and equipped with population, demographic, and historical factors taken into account. Districts, then presumably operate under a "level playing field" in their attempt to make their assigned goals. From year to year, districts are assigned and receive a fair and proportionate amount of manning, money and goal to match their market and size.

In fiscal year 1998, NRD San Diego, a historical powerhouse in Navy Recruiting, failed to achieve its monthly New Contract Objectives (NCO) ten out of twelve months.¹ Subsequently, the district failed to meet its yearly New Contract goal.² Table 1 summarizes San Diego's New Contract Objective and Accession Goal attainment over the time periods covering fiscal years (FYs) 1997-2000.

Just the year before, the district overwrote its yearly New Contract goal by 150 contracts. Part of the demise was a large goal increase. The goal was 384 more contracts than the previous year. Unfortunately, even with seasoned leadership and an increase in manning, the organization could not perform effectively with the new demands placed upon it. San Diego was not alone. Only one district in the nation made goal that year. However, San Diego "bounced back" in 1999, making goal and earning selection as Commander, Navy Recruiting Command's (CNRC's) National District of the Year. Most of the nation's other districts, however, continued their slow recovery. In fact, it was not until a nationwide goal decrease in 2001 and downturn in the economy that most districts achieved consistent NCO attainment

The purpose of this study is to determine those factors that affected organizational performance of Navy Recruiting District, San Diego by comparing two distinct time

¹ A fiscal year starts in October and ends in September of the next year to coincide with the federal budgeting schedule.

² New Contract Goal, NCO, and "goal" are different ways to say the same thing, the number of new contract quotas assigned to the district either on a yearly or annual basis. The term "goal," will be preceded by the type of goal if meant for anything other than new contracts. For example, if the study discusses accession goals, then the word "accessions" will specifically precede the word "goal."

periods: FYs 1997-1998, and FYs 1999-2000. Using a systems analysis, factors will be identified which may have contributed to the successful or unsuccessful performance during the four-year period.

FY	1997	1998	1999	2000
New Contract Objective	2010	2394	2540	2610
New Contract Objective Attained	2160	2220	2555	2766
% New Contract Objective Attained	107%	93%	101%	106%
Accession Goal	100%	100%	100%	100%

Table 1.0. NCO/Accession Attainment Summary NRD San Diego: 1997-2000.

B. METHODOLOGY

This thesis uses a four-step approach to analyzing NRD San Diego. First, a literature review is conducted of systems theory to obtain the tools necessary for analysis. Second, to help understand the context of the analysis, a general description of a Navy Recruiting District is provided within the literature review. Third, NRD San Diego is analyzed during the four-year period using a Systems Model and Fit “Checklist”, comparing the system that existed in 1997-98 with that of 1999-00. Finally, conclusions and recommendations are offered to assist managers in achieving better organizational performance.

C. BENEFIT OF THE STUDY

Research through interviews and data collection indicates that many districts are currently mired in the same situation as NRD SD in FY97-98. The study describes in detail those factors that may have caused the inefficiency of that particular organizational system. Possible avenues for change will be suggested, which may lead to improvements and hopefully, mission accomplishment. In fact, leadership at any recruiting district that is failing to make goal, regardless of their specific market, can read this thesis and determine if any of the organizational changes that occurred applies to their situation.

D. SCOPE AND LIMITATIONS

The data used in the thesis are primarily derived from approximately 72 interviews and personal conversations. The lessons learned specifically apply to NRD

San Diego, although some general applications may be applied to other recruiting districts. As well, more data was retrieved for the 99-00 time period than for the 97-98 system because many of the recruiters, zone supervisors and leadership from the earlier era were not accessible. There were, however, approximately 30 individuals from the 99-00 time frame who also served briefly (at least 3 months) in 97-98.

E. ORGANIZATION OF THE THESIS

Chapter II is a literature review. It discusses systems theory and its use in analyzing organizations. Subsequently, the review describes the basic systems model which is used as the basis for analysis. As well, a specific checklist of fit method is discussed. The chapter also provides the necessary context to understand the Navy Recruiting System and the organization of a Navy Recruiting District. Chapter III discusses the model results. The systems model is used to compare and contrast those inputs, design factors, culture(s) and outputs/outcomes prevalent in both time periods. The chapter concludes by analyzing the congruence of fit between the various elements of the two models and the environmental influences on the two systems. Finally, Chapter IV offers conclusions in the form of similarities and differences, and recommendations based on the analysis.

THIS PAGE INTENTIONALLY LEFT BLANK

II. LITERATURE REVIEW

A. SYSTEMS THEORY

This study uses an organizational systems model³ to analyze Navy Recruiting District, San Diego (NRD SD) in two distinct time periods. Systems thinking arose from the study of systems dynamics, founded in 1956 by MIT professor Jay Forrester.⁴ The systems approach looks at the organization as a whole, how its individual components “fit” with each other and its external environment. This runs contrary to other methods of analyses that focus exclusively on individual parts.

McNamara (2002) provides the following definition of a system:

A system can be described as a collection of parts or subsystems, integrated to accomplish an overall goal. Systems have an input, processes, outputs and outcomes, with ongoing feedback among all the parts. The system also incorporates the environment, and for social systems: culture is a factor. If one part of the system is removed, the nature of the system is changed.

A system can range from very simple to complex. There are numerous types of systems. For example, a heart is a biological system, while a thermostat is a mechanical system. Human/mechanical systems include riding a bike while a predator/prey relationship is an example of an ecological system. Complex systems, such as social systems, are comprised of numerous subsystems as well. Each subsystem has its own boundaries, and includes separate inputs, processes, outputs and outcomes geared to accomplish an overall goal for the subsystem.

A pile of sand is not a system. If one removes a sand particle, there’s still a pile of sand. However, if you remove the carburetor from a car, there’s no longer a functioning system.⁵

An organization can be analyzed as a system. McNamara continues,

Systems theory has brought a new perspective for managers to interpret patterns and events in their organizations. In the past, managers typically took one part and focused on that. Then they moved all attention to another part. The problem was that an organization could, for example,

³ Roberts, Nancy, Naval Postgraduate School, Monterey, CA, 2000.

⁴ Arons, Daniel, “Overview of Systems Thinking,” 2002.

⁵ McNamara, Carter, “Thinking About Organizations as Systems,” from http://www.mapnp.org/library/org?thry?org_sytm.htm, downloaded 10/18/2002.

have wonderful departments that operate well by themselves but don't integrate well together. Consequently, the organization suffers as a whole.⁶

Harrison (1987) adds:

A model of an organization as an open system can help practitioners choose topics for diagnosis, develop criteria for assessing organizational effectiveness, and decide what steps, if any, will...help solve problems and enhance organizational effectiveness.⁷

Systems thinking has identified several principles of "fit" that are common to systems. These principles help one to better understand how organizations work. They include:

- ***The system's overall behavior depends on its entire structure (which is more than the sum of its various parts).*** The structure determines the various behaviors, which affect various outcomes. The traditional method of breaking up an organization into separate parts, analyzing the parts, and ignoring their relationships is ineffective. As McNamara says, "when you break apart an elephant, you don't get little elephants."

Organizations are constantly changing as relationships among key variables shift. An organization's responses to internal and external changes depend on members' interpretations of these changes and their decisions about how to deal with them. Information about internal and external developments flows through both official and unofficial channels. Small changes in one part of the system may not require more than routine adjustments in other elements, but major changes in one element can set off a series of changes in others.⁸

- ***Systems tend to seek balance with their environments.*** On the contrary, those that do not interact with their environment, tend to be ineffective.⁹

An organization's success depends heavily on its ability to adapt to its environment-or to find a favorable environment in which to operate-as well as on its ability to tie people into their roles in the organization, conducts its transformative process, and manage its operations.¹⁰

Environment influences the flow of inputs to organizations, design factors and results.

⁶ Ibid.

⁷ Harrison, Michael I., *Diagnosing Organizations: Methods, Models and Processes*, Sage Publications: London: 1987, p. 23.

⁸ Harrison, 1987, p. 26.

⁹ McNamara, p. 2.

¹⁰ Harrison, 1987, p. 27.

- *There can be an optimum size for a system.* A system can be too large. In the same way, a system “bite off more than it can chew.” As well, there are systems that can expand that are not performing up to their potential.¹¹
- *A circular relationship exists between the overall system and its parts.* Problems seem to cycle through an organization over and over again. Unless harmful cycles are recognized and changed, problems continually re-surface.

B. THE BASIC SYSTEMS MODEL

The systems model is used to gather basic organizational information at the beginning of the organizational diagnosis, followed by an analysis of the system congruence using the gathered information.¹²

There are several versions of the systems model used in organizational analysis. The model used in this analysis is adapted from Roberts’¹³ Organizational Systems Framework (see Figure 2.1) and from a description provided by Harrison.¹⁴ This study gathers basic organizational information on the organizations using the systems model described below.

All parts of the model affect each other. Although the model suggests that the flow of the system is sequential and linear, the parts of the model are actually independent and the activity is concurrent. The main elements basic systems model consists of Inputs, which include the Context (environment, resources and history), Critical or Key Success Factors, and System Direction. Environment is actually *external* to the system and includes external organizations, economic states, political policies and other external entities or forces that influence the *entire* system. The inputs are linked to the Design Factors, which include the Tasks, Technology, Structure, People and Processes/Subsystems of the organization. Culture is an emergent or resultant variable largely determined by the preceding phases. Outputs are goods and services produced and Outcomes are consequences of outputs. Feedback Loops mean the system is dynamic and interdependent.

¹¹ McNamara, p. 2.

¹² Harrison, 1987, p. 27.

¹³ Roberts, Nancy, Naval Postgraduate School, Monterey, California, 2000.

¹⁴ Harrison, 1987, p. 23.

ORGANIZATIONAL SYSTEMS FRAMEWORK

I
N
P
U
T

T
H
R
O
U
G
H
P
U
T

R
E
S
U
L
T

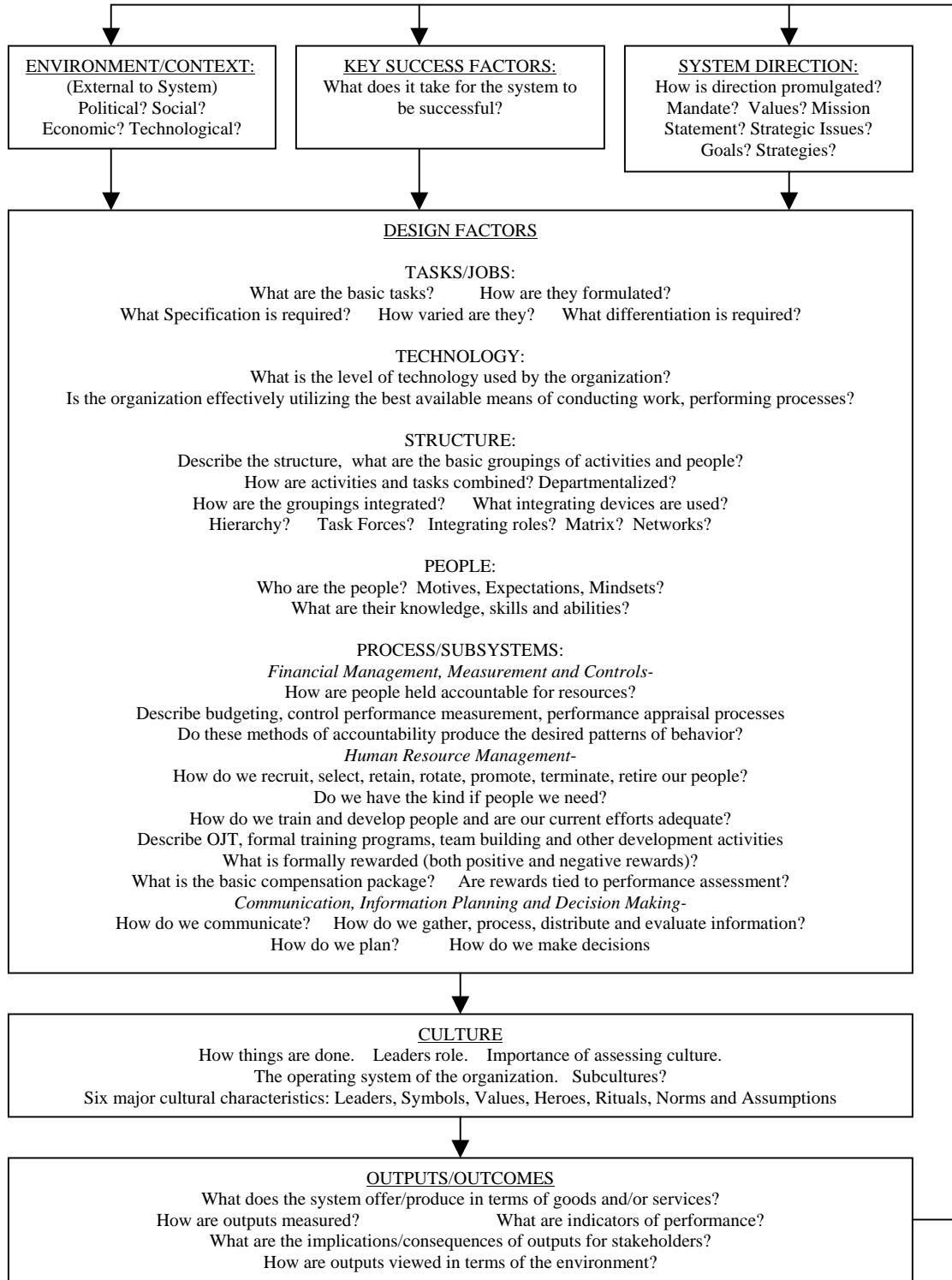

Figure 2.1. Organizational Systems Framework¹⁵.

¹⁵ Adapted from Nancy Roberts, Naval Postgraduate School, Monterey, CA, 2002.

The following is a detailed description of the organizational systems framework model which will be used to obtain basic organizational information for each time-frame.

1. Inputs

a. Context

According to Nadler and Tushman¹⁶, context comprises the elements that make up the “givens” facing an organization. One of the most important givens and a significant influence on the system as a whole is its environment. Environment is an external factor to the organizational system. The environment includes individuals, groups, or other organizations that affect how the organization performs. The environment also includes the political, economic, social and technological influences. When analyzing an organization, one must consider the factors in the environment and how they create demands, constraints, or opportunities.

Other contextual factors not specifically included in the Roberts model are resources and history. Resources are simply the assets an organization, such as employees, technology, capital, and information.

History describes the influence the past has on the organization’s performance. An organization’s past performance and the impact of historical events on that performance can be significant factors in the current performance of an organization.

b. Key Success Factors

Simply put, what does it take for the system (organization) to be successful? “Management must ask sufficient questions to ascertain the requirements essential for success.”¹⁷ Success factors for each organization may be different. In fact, an organization may define different success factors from year to year. Governmental organizations may have success factors that are less tangible than private, profit-based organizations. However, some public organizations, like recruiting districts and the quotas they must attain, have measurable success factors. There may also be success factors that are considered more important than others. These secondary success factors

¹⁶ Nadler, D. and Tushman, M., *Strategic Organizational Design*, Scott Foresman and Company: Glenview, Illinois, 1988.

¹⁷ Bruner, Bradley, *An Organizational Analysis of the Military (Navy) Personnel Plans and Policy Division (N13)*, Naval Postgraduate School, Master’s Thesis, Monterey, California, 1998, p. 10.

may or may not be accomplished, but are not considered essential in order for the organization as a whole to be considered successful.

c. System Direction

This input in the model asks the question: how does the organization disseminate the strategy, mission, goals and direction to the employees and the public? Does the organization mandate, suggest, or guide? Of course, the type of direction varies with every organization. Some may use a vision statement, while others use strategic goals. Still others simply *tell* the organization through top-down directives through such mediums as e-mail, faxes or letters. Finally, the management may lead by example, hoping the rest of the organization follows suit.

2. Design Factors

The next stage in the system is throughput, which is made up of design factors. These design factors are the individual components of the organization. Although system fit amongst all the elements of the system is important, congruence among these specific design factors is often critical for organizational success:¹⁸

a. Tasks/Jobs

What are the basic tasks that need to be accomplished in the organization? Do the lower level employees, middle management and top executives perform clearly defined tasks? Each organization contains within it different types of work, from management to manual labor. The nature of each type of work must be clearly defined in order to be efficient.

b. Technology

The level of technology employed by the organization in areas such as information systems, communication, data storage and collection, internet, local area networks and computers, has a significant effect on the effectiveness of the organization.¹⁹ Obviously, increased technology usually requires increased financial and time investments, which some organizations simply cannot afford. Other organizations choose not to upgrade their technology because they feel they are accomplishing the mission of their organization with their current technology.

¹⁸ Ibid.

¹⁹ Simon, Cary, Personal Communication at Naval Postgraduate School, Monterey, CA, May 2002.

c. Structure

Structure describes the organizational hierarchy, or lack thereof, of the organization. It also describes the people and their integrating roles, as well as any matrices of sub-organizations that occur within the overall system. Structure also answers the question: Are there task forces and/or special networks involved in the organization?

d. People

The people design factor refers to not only the knowledge, skills and abilities (KSA's) of the people involved in the organization, their demographic background, and experience.

e. Process/Subsystems

There are several processes and subsystems that each organization performs:

- Human Resource Management (HRM): This subsystem answers the question: "How does the organization recruit, select, rotate, promote, terminate and retire their people?" HRM is also concerned with obtaining the right people for the job. Additionally, it answers how the organization trains, and develops its people. Does the organization use OJT, formal training programs? Does the organization use Team Building and/or organizational developmental activities? Is the organization concerned with career development? HRM is also concerned with rewards and praise and how they are tied to performance.
- Measurement and Controls, Financial Management: This subprocess is concerned with the mechanisms and processes designed to hold individuals accountable for behavior and resources. The subprocess includes performance appraisal and measurement and budgetary controls. Recruiting districts have different ways of measuring the performance of their recruiters.
- Planning, Communication and Information Management: Planning may involve extensive meetings, video-teleconferencing, and/or written guidance. As well, how does the organization communicate on a day-to-day basis? Some organizations use meetings as the primary information exchange venue. Some organizations use informal calls and/or e-mail to talk to each other. Still others may combine both informal and formal aspects of communication. Information management is an extremely critical subprocess for many organizations. Organizations such as recruiting rely on statistics to determine trends and predict performance. How information is gathered and used may help to explain the success of an organization.

3. Culture

The culture of an organization is an important factor to consider during analysis. Culture pertains to the prevalent norms and values found in a system. It is the way the organization conducts business. Culture “drives the organization and its actions. It is somewhat like an ‘operating system’ of the organization. It guides how employees think, act and feel. It is dynamic and fluid, and it is never static. A culture may be effective at one time, under a given set of circumstances and ineffective at another time.”²⁰ Analysts must study culture “to maximize its ability to attain strategic objectives, the organization must understand if the prevailing culture supports and drives the actions necessary to achieve those goals.”²¹

Another definition of culture is “a pattern of basic assumptions, invented, discovered, or developed by a group as it learns to cope with its problems of external adaptation and integration; that has worked well enough to be considered valid, and therefore has to be taught to new members as the correct way to perceive, think, and feel in relation to their problems.”²²

Hagberg and Heifetz (2002) say the following about culture:²³

- ***Culture can become ingrained and unconscious:*** Culture can be viewed at several levels. Some aspects of culture are visible and tangible and others are intangible and unconscious. Basic assumptions that guide the organization are deeply rooted and often taken for granted. Recently hired employees, the external consultant and the executive coach are frequently in the best position to identify those “unconscious” assumptions that the insider fails to see. Espoused or secondary values are at a more conscious level; these are the values that people in the organization discuss, promote and try to live by. All employees of Hewlett Packard, for example, are required to become familiar with values embodied in the “HP Way.”
- ***Artifacts express culture:*** Some of the most visible expression of the culture are called artifacts. These include the architecture and décor, the clothing people wear, the organizational processes and structure, and their

²⁰ Hagberg, Richard and Heifetz, Julie, “Corporate Culture/Organizational Culture: Telling the CEO that his/her Baby is Ugly,” Downloaded from <http://www.hcgnet.com/html/articles/understanding-culture.html>, 2002, p. 2.

²¹ Ibid.

²² Schein, E., *Organizational Culture and Leadership: A Dynamic View*, Jossey-Bass: San Francisco, 1985.

²³ Hagberg and Heifetz, p. 3.

rituals, symbols and celebrations. Other concrete manifestation of culture are found in commonly used language and jargon, logos, brochures, company slogans, as well as status symbols such as cars, window offices, titles and of course value statements and priorities. An outsider can often spot these artifacts easily upon entering an organization. For insiders, however, these artifacts have often become part of the background.

- ***The Leader can drive culture:*** One of the critical factors in understanding a corporate culture is the degree to which it is leader-centric. When one asks the question: How central is the leader to the style of this organization? The organization's culture often reflects the personality of the leader, including that leader's neurosis. So if a CEO tends to avoid conflict and sweeps it under the carpet, the company then tends to avoid conflict. The behavior that is modeled by the leader and the management team profoundly shapes the culture and practices of the organization. What management emphasizes, rewards and punishes can tell you what is really important. The behavior of members of the senior team, their reactions in a crises and what they routinely talk about, all sets the tone of the culture. If the culture is already firmly established when the CEO assumed leadership and he/she simply inherited a set of traditions, then he/she may play the role of the guardian of the old culture. On the other hand, CEO's such as Lou Gerstner at IBM, or Lee Iococca at Chrysler were brought in to be a change agent charged with dramatically transforming the organizational culture.
- ***Subcultures may exist:*** Many organizations may possess one pervasive culture, with several less impacting subcultures. Many others contain a mixture of several subcultures. It may be unrealistic and undesirable to try and homogenize the organization across all of its parts. It may be worthwhile, however, to eliminate or weaken any detrimental subcultures within the organization.

In sum, there are six characteristics that characterize and influence culture in an organization:²⁴

- **Leadership:** Establishes the vision and sets the example for the culture in such a way that leads the organization towards mission accomplishment.
- **Symbols:** Physical or visual reminders of important safety values.
- **Values:** Spoken principles that guide the decisions of workers and managers.
- **Heroes:** Organizational members that role model the values.
- **Rituals:** Regular celebrations, ceremonies or activities that reinforce the importance of success.

²⁴ Simon, Steven I. "Measurement as a Transformative Tool: The Culture Assessment", downloaded from <http://www.camcoderinfo.com/ccs/measurepaper.html>, October 22, 2002.

- **Norms and Assumptions:** Norms are the group's expectations for safe behavior. Assumptions are the beliefs about what is accepted and what is not.

Culture derives from the previous phases of the systems model. Everything that occurs prior, inputs, system direction and design factors, all work to develop the culture of the organization. Culture transforms when any of the previous factors are changed.

4. Outputs and Outcomes

The end product of the organization and the "final" phase of the model are the outputs and outcomes. What is the organization producing? What goods and services does it provide? Output can usually be measured. It is a measure of how well an organization meets its objectives and utilizes resources. The output is often based on the method of measurement and is typically the performance indicator in an organization. Outcomes deal with the implications and consequences that outputs have on stakeholders and how the outputs are interpreted in view of the environment. In order to be an integrated system, the outcomes must feed back to the environment and the design factors.

C. ANALYSIS OF SYSTEM FIT

The overall goal of systems analysis is to determine the congruence of fit between all the factors that make up the system in order to achieve the critical success factors. That is, the analysis attempts to answer such questions as "Do the tasks match the structure?" or "does the technology fit with the people?" or "Do the design factors result in an effective culture?" All these factors must work and fit together to produce an effective system.

A systems model is useful when analyzing organizations because it shows the interrelationship between all the factors that influence an organization. Systems theory assumes that an organization can be thoroughly analyzed only by looking at the sum of all parts and at the congruence, if any, between them. If the different parts of an organization fit well together, the organization is likely to perform better. If the pieces are not operating at a high level of congruence, then the organization will likely experience problems, dysfunction, and poor performance. The basic hypothesis of the

congruence model is that organizations will be more effective the greater the congruence or fit between the major components.²⁵

This study analyzes congruence using Harrison's (1987) Checklist of Important Fits (Table 2.0). The table presents those questions that "research and consulting practice have shown to be especially important" in analyzing the effectiveness and efficiency of organizations.²⁶ Some of the questions were modified for this study. Harrison categorizes these components into "Focal Areas." Elements of the system are categorized under the Focal Areas and analyzed for fit using Harrison's questions. The method essentially answers the question: "Does the focal area fit with the system element?"

To quantify the overall level of fit of the system, values were assigned to the answers given to each question. An answer of "YES" equals a score of "2"; an answer of YES and NO equals a score of "1"; and an answer of "NO" equals a score of "0." The higher the total score the better the congruence of fit of the system. Therefore, positive answers to the questions provided by Harrison's method result in better congruence between system elements.

D. GENERAL OVERVIEW OF A RECRUITING DISTRICT

A general overview of a recruiting district is required in order to understand the systems models presented for NRD San Diego. The overview gives insight and clarification as to the missions, organization, resources and processes of a typical recruiting district. The primary source of information for this chapter were the CNRC Standard Organization Manual (CNRCINST 5400.1F), the CNRC Recruiting Manual (CNRCINST 1130.8) and the Standard Operations Manual (CNRCINST 5400.2).

The 31 NRD's are geographically separated into four regions: North, West, South and Central. NRD San Diego is located in Region West. Each region is led by a Commodore (0-6). NRDs are divided into the following departments: Logistic Support, LEADS, Administration, Public Affairs, ADP (System Administration), Officer Programs and Enlisted Programs.

²⁵ Bruner, 1998, p. 13.

²⁶ Harrison, 1987, p. 76.

Focal Area	Fits with?	Analysis Question
Human Resources	S T Pr	Did employees' skills and training fit their job requirements?
		Were the best people attracted and retained by the rewards and advancement opportunities offered?
System Direction	R	Were the organization's strategies and programs be supported by available resources?
	E	Did the organization's strategies, tactics and objectives help it gain and maintain a favorable position in its environment?
	Pr C	Did management express its purposes in ways that create a sense of mission and identity among members?
		Were efforts to change the organization compatible with current norms, behavior and assumptions?
C Pr	Did managerial plans and objectives contribute to work, or were they too inflexible to handle unforeseen developments?	
Processes	S C	Were those people who must work together closely grouped in units or otherwise linked structurally?
		Were the procedures for coordinating work and information flows appropriate for the tasks and the technology?
		Were task that are poorly understood or require creativity and innovation handled by organic structures?
	S	Are tasks and functions done adequately with minimal overlap?
Structure	Pe Pr C	Did members regard official rules and procedures as fair and sensible?
		Did reward and control mechanisms encourage behavior and group norms that were compatible with managerial objectives?
	T E	Were the structures of the organization differentiated enough to allow them to handle their special problems created by their particular environments, technologies and tasks?
	T Pr	Did the physical and geographic layout of the organization contribute to the flow of work and information?
	Pe Pr	Were group actions and decisions free from bitter conflicts or power struggles?
		Did rewards and controls encourage desirable competition?
Did people and units have enough power and resources to accomplish their tasks adequately?		

KEY: S- Structure T- Technology Pr-Processes R-Resources E-Environment C-Culture Pe-People

Table 2.0. Harrison's Checklist of Important Fits.

A typical NRD is also divided into geographic zones. Depending on the size of the district, there could be as little as four zones to as many as a dozen. The zones contain a specific number of recruiting stations. Zone supervisors lead the zones, and the

stations are led by Recruiters-In-Charge (RINCs). These RINCs, who supervise the recruiters in their stations, report directly to their zone supervisors.

1. Mission

The mission of a Navy Recruiting District (NRD) is as follows:

Manage recruiting activity within the assigned Navy Recruiting District in the recruitment of men and women who meet mental, moral, physical and other specific standards for enlistment or reenlistment; obtain the best qualified men and women applicants from civilian sources for enlistment as officer candidates and for direct appointment as officers in the Regular Navy and Naval Reserve.²⁷

The major responsibilities of an NRD are to make goals, manage resources and improve Navy awareness.

2. Organization

The focus of the description will be on the **enlisted production function** of the organization.

a. Executive Leadership

The Commanding officer is usually an 0-5 Unrestricted Line, Fleet Support (1100), or Human Resources (1200) Officer, who “fleets up” from an 18 month tour as the command’s XO. The CO serves an 18 month tour. The Command Master Chief (CMC) is a fleet sailor who may or may not have prior recruiting experience. The CMC is the principal enlisted advisor to the Commanding officer.

b. Support Departments

(1) Logistics Support. Each district has a Supply Department typically led by a Storekeeper Chief Petty Officer or higher, known as the Logistics Support Officer (LSO). The department is responsible for all vehicles and facilities. As well, the LSO employs a civilian Budget Assistant (BA) who executes and plans the command budget. The LSO also performs all the purchasing for the command.

(2) LEADS. The Local Effective Accession Data System (LEADS) department is led by the LEAD Tracking Center Supervisor (LTCS). The LTCS can be a fleet or CRF sailor (usually a chief petty officer or above). The LTCS supervises the generation, processing and tracking of leads through newspaper

²⁷ COMNAVCRUITCOMINST 5400.1F, p. 11-1.

advertising, direct mail and other local advertising. The LTCS also tracks all National Leads forwarded to the Officer/Enlisted recruiting force as prospects for enlistment/selection into the Navy. Finally, the LTCS must also be able to perform as a recruiter. .

Leads are either national or local. National leads are those received through nation-wide advertising campaigns, such as the web-site and television commercials. Local leads are generated through local advertising campaigns conducted by each district.

Typically, a recruit will be asked by the recruiter “what brought him into the recruiting office” or “what got him interested in the Navy.” If the recruit mentions a specific advertisement, or if they saw something such as a recruiting poster that piqued their interest, the recruiter will note the “lead” and send the information to the district’s leads department. If the recruit joins the Navy, the lead will help to show which advertising campaigns are successful.

(3) Chief Administrator (CA)/Administration (Admin) Department. The Chief Administrator (CA) supervises the command’s administration department. He or she is typically a Personnelman (PN) or Yeoman (YN) Chief or above. The CA implements administrative and personnel policies and is responsible for the efficient and effective administrative functioning of the NRD. The CA usually supervises the typing of officer and enlisted fitness reports and evaluations, and maintains the command reports tickler files.

(4) Public Affairs Officer (PAO). The PAO is the principal advisor to the CO on all public affairs activities. He or she ensures efficient and effective planning and execution of these activities. The job can be a collateral duty for an officer or enlisted recruiter; or the command can have a Journalist (JO) or Photographer’s Mate (PH) assigned to the command.

One of the primary duties of the PAO is to maintain active liaison with print and electronic media. The PAO also writes articles and places news and feature materials in local media, including DEP news releases. The PAO visits media outlets frequently with the commanding officer and/or recruiters to promote public

services advertising.²⁸ The PAO can also act as the command spokesperson on military issues. Finally, the PAO is also the command's newsletter publisher and liaison for all visiting navy performance teams (The i.e. Blue Angels) and traveling exhibit vans.

(5) Educational Specialist (EDSPEC). The EDSPEC (EDSPEC) is a civilian employee of the command who is the expert on all matters related to applicant education. Since a high school diploma is one of the qualifying criteria that applicants have to meet, EDSPECS are an invaluable member of the production chain. EDSPECs can distinguish between qualifying and non-qualifying education credentials, especially those credentials associated with home-schooling and alternative education programs. Figure 2.2 describes the organization of a typical NRD (with an emphasis on the enlisted programs function).

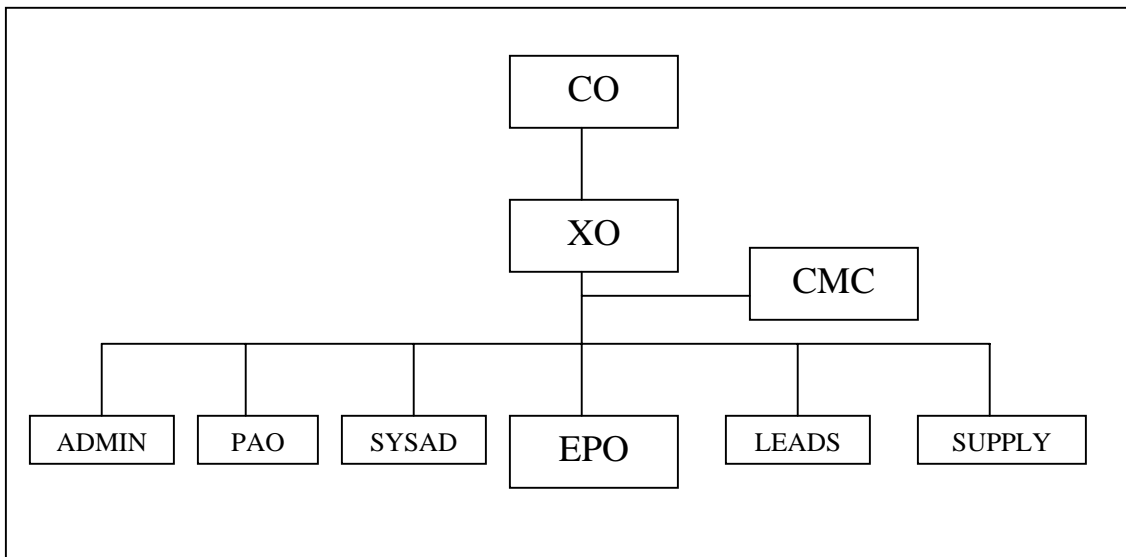

Figure 2.2. Typical Command Organization.

c. Enlisted Programs Department

This section describes the Enlisted Programs Department, the organization responsible for making enlisted goals. The department is led by the Enlisted Programs Officer (EPO). The EPO usually has the most personnel in the command under his/her

²⁸ COMNAVCRUITCOMINST 5400.1F.

department. With the job comes the most responsibility, as compared to other department heads. Most districts put the EPO in charge of not only his own headquarters staff, but also the Military Entrance Processing Station(s) (MEPS) and the recruiters (FIELD). Figure 2.3 shows a typical organizational structure for the enlisted programs department.

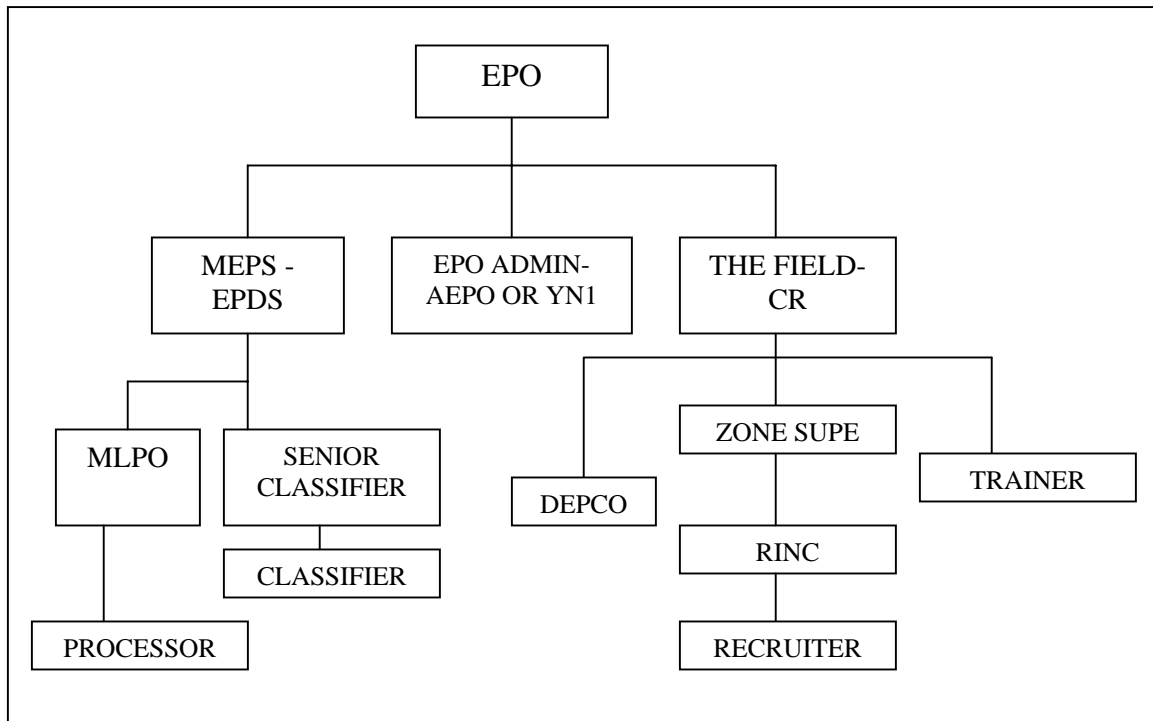

Figure 2.3. Typical Enlisted Programs Department.

The EPO is usually an 0-3 or 0-4 unrestricted or restricted line officer, although some districts may employ Limited Duty Officers (LDO's) or Master Chief Petty Officers in both permanent and temporary functions. The EPO's office is usually located at the headquarters building, along with the rest of the leadership team. Although the EPO has a long list of duties and responsibilities, most of them are delegated through his extensive organization chain.

The EPO is responsible for most of the administrative paperwork involving his recruiters and MEPS personnel. These include performance evaluations, recurring reports, legal inquiries, DEP files, and PQS. Other areas of administrative concern for the EPO over his department include:

- Monitoring vehicle operation, domicile to duty and safe driving programs
- Maintaining expeditious publication of current information and changes
- Maintaining accountability of assigned property
- Ensuring all property security procedures are followed
- Ensuring proper military bearing and dress for personnel
- Recommending rewards or remedial action regarding performance
- Attending and participating in Zone/NRD Production, Planning, Training meetings

The EPO has an integral role in the resource planning of the district. EPOs assist in developing the district's marketing operations, training, advertising and financial plans. The EPO distributes and monitors the expenditure of assigned funds in accordance with the command's budgetary plans. The EPO also ensures the efficient use of all assigned resources and monitors and distributes RAD (Recruiter Aid Devices) items. The EPO also recommends placement of personnel in the field and support assignments.

The Enlisted Programs Officer provides feedback information to update the District's MOP (Marketing Operations Plan) based on the analysis of its accomplishment. He or she also develops department production plans to ensure consistent attainment of enlisted recruiting goals. The EPO also ensures that a current STEAM²⁹ is conducted and used throughout the NRD Enlisted Programs Department.

The EPO compiles, reviews and submits input to the annual training plan and implementing the district/CNRC training plan. More specifically, the EPO schedules, prioritizes, conducts, monitors, enforces, evaluates, adjusts, documents and inspects his department's training program. A significant responsibility the EPO has towards the fleet sailors is to ensure in-rate study time is provided to them for advancement exams. Finally, the EPO ensures the department is in compliance with CNRC's Recruiter Qualification Standards (RQS)³⁰ policy.

The EPO supervises the Chief Recruiter to ensure the attainment of goals is the primary responsibility with regards to recruiting. The EPO must also identify

²⁹ Standard Territory Evaluation Analysis Market.

³⁰ Similar to Personnel Qualification Standards, completion required to qualify for certain positions.

weaknesses and/or deficiencies in the DEP program and assists the CR in training them, especially to reduce or eliminate attrition. The EPO keeps a watchful eye on the specialty recruiting programs such as Nuclear Power. There should be a close recruiting relationship with the Officer Programs Officer to ensure mutual recruiting benefits. Some enlisted applicants may be eligible for officer programs and vice versa. Liaison with local educational, labor and governmental employment personnel is maintained by the EPO. The EPO is also the link between the active duty recruiting programs and the reserve recruiting activities. As well, the EPO should maintain a database on Qualified Not Enlisted (QNE)³¹ personnel.

The EPO is responsible for supervising the Enlisted Processing Division Supervisor (EPDS) to ensure proper processing procedures. The EPO should also maintain liaison with the MEPS Processing team (Operations Officer, Testing Officer, and MEPS Commanding officer) to ensure expeditious and courteous processing for Navy applicants. EPOs should also establish an applicant control system to meet MEPS and Recruit Training Command “level-loading”³² requirements. MEPS and RTC only have a certain amount of man-hours and equipment for the processing of personnel per day. The EPO must ensure that the applicant flow can be accommodated by both MEPS and RTC. Within the processing procedure itself, the EPO ensures that the classification interview system is efficient. Finally, EPOs ensure that applicants and enlistees are accounted for within the district.

The EPO regularly reviews kits of waiver³³ applicants. He or she ensures the kits are properly processed. In addition, the EPO can also conduct interviews when allowed by CNRC. As well, he reviews pre-enlistment kits and error feedback information. Lastly, he is responsible for waiver and attrition analysis for both the Delayed Entry Program and Recruit Training Command. The following section describes

³¹ QNE's (Qualified, Not Enlisted) are those applicants who have passed the ASVAB and are qualified medically, and academically but for whatever reason, just do not want to enlist. The EPO should be aware of these potential recruits for they may change their minds and decide to enlist later.

³² RTC is limited by the number of seats it has available in bootcamp, requiring that recruits enter bootcamp in a steady stream as opposed to unbalanced accession patterns.

³³ Applicants can receive waivers for various reasons including minor drug and criminal infractions and medical irregularities.

the three “divisions” under the EPO’s responsibility: EPO Administration, MEPS Liaison, and the recruiters.

(1) EPO Administration. One of the key figures in the command is the Statistician who maintains and reports all the statistics for the recruiters. These statistics usually include goals assigned and attained for the zones and stations. Individual NCO accomplishment, program goals (nuke, mental category and minority category) and attrition are other statistics that can be maintained and reported. The statistics can be reported on a daily or weekly basis. A statistics reporting system could range from an elaborate electronic set-up with an automatically updated database and fancy reports (possibly in Microsoft EXCEL), to archaic pen and ink systems that require tedious hand-computations. The statistician is the driving force behind the maintenance of enlisted production/processing accountability.

Other EPO Administration Team Members include a Yeoman or Personnelman (EPO Administrator or EPO YN). The EPO YN conducts a variety of administrative duties, such as evaluation writing and chit routing.

In addition, the EPO can also have, but not always, the following members of his EPO Admin team: an Assistant EPO, and DEP Coordinator. The Assistant EPO can be an Enlisted or Officer who aids in the EPO in his duties. The DEP Coordinator’s duties vary in each district, with the primary focus being the focal point for DEP activity and management.

(2) The Field. The Chief Recruiter (CR) leads the recruiting function of a recruiting district. The CR serves in the role of a division officer for the field under the EPO. The CR is the primary supervisor of all the field recruiters and is held responsible for making all goals. The CR is usually a CRF Master or Senior Chief Petty Officer with extensive recruiting experience as a recruiter all the way up to zone supervisor. Some CR’s are on their second or third CR tours. The CR is, bottom line, the subject matter expert on recruiting. According to CNRCINST 5400.1F, the CR’s job description is as follows:

Serve as the Department Leading Chief Petty Officer. Train zone supervisors, district trainers, DEP coordinator(s) and special program recruiters. Manage, supervise and coordinate the use of all NRD resources, training and systems to attain enlisted goals. Serve as the

primary advisor to the Commanding officer in matters pertaining to enlisted production.

The primary areas of concern as outlined below:

- Production. The CR assigns all goals to the zones and ensures monthly goaling notices are distributed to the field. The CR monitors and analyzes NRD processing/prospecting activity to ensure objectives are being met.
- Training. The CR implements the CNRC/district training plan. The CR also schedules, prioritizes, monitors, conducts, enforces, evaluates, adjusts, documents, and inspects the plan. CRs must allow for in-rate study and comply with CNRC's PQS policy.
- Managing Resources. The CR's duties with regard to resource management are the same as the EPO's except for several points. The CR acts as the primary advisor to the CO on all matters related to the DEP. The CR is the focal point for any NRD directives related to DEP. The CR ensures the ZSs, district trainers, 6YO/NF recruiters and DEP Coordinator attain applicable milestones specified in the District MOP. The CR also coordinates all gains, ensuring incoming personnel have a sponsor and NRD.

The CR directly leads a team of Zone Supervisors, or "zone supes." They are usually but not exclusively CRF's, and are in charge of a specific number of recruiting assigned to their zones. Zone supervisors are extremely significant members of the recruiting process. Many, including CNRC, consider zone supervisors as the most "important level of leadership in the recruiting process."³⁴ The zones they supervise are usually set up geographically, but can include stations that cross geographic boundaries. For example, some districts split up their high producing zones, giving individual NRS' from each to other less productive zones.³⁵

Zone supervisors have a high level of authority over personnel and resources. They control (as many as) dozens of recruiters, the buildings they occupy, and the government vehicles they drive. Their monthly NCO goals can sometimes reach into the 30's and 40's, and for many large zones, in the 50's and 60's. They also ship out a comparable number of DEPpers to bootcamp each month.

Zone supervisors manage DEP pools which can number in the hundreds. They manage these civilian personnel in addition to their own military cadre.

³⁴ Commander Navy Recruiting Command, at a presentation at Naval Postgraduate School, 2002.

³⁵ Interview with CR NRD San Diego, May 2001.

They qualify as zone supervisors through a rigid qualification process culminating in an oral board chaired by the Regional Commodore. They are allowed a separate office away from the headquarters and the recruiting stations.

Zone Supervisors are vital to the success of the command's training program. They implement command and CNRC training plan within the zone, identify and train to all weaknesses and/or deficiencies in prospecting, sales techniques, required system use and processing procedures, ensure compliance with the CNRC PQS policy (COMNAVCRUITCOMINST 1136-ENL) and ensure zone personnel are progressing towards advancement and in-rate study time is provided

The zone supervisors directly lead the Recruiters In Charge (RINC's). RINC's supervise recruiting stations and the recruiters assigned to those stations. They can be fleet or CRF sailors of any rank and usually have prior recruiter experience. They should have completed PQS to qualify as a RINC.

The RINC is an extremely important figure in the production process. He is essentially in charge of an auxiliary navy "command" located in the public domain. He must be sure that his station does not discredit the US Navy in any way, knowing that any negativity associated with his station reflects directly on the Navy.

Additionally, depending on where he is geographically located, he may no direct supervision. The RINC is responsible for the production and accountability of his recruiters. The RINC must definitely be trustworthy. RINC's train recruiters and essentially serve as the work-center supervisor for their NRS.

The RINC's areas of responsibilities and specific duties are outlined below:

- Prospecting
 - ensure accuracy and completeness of prospect cards
 - initiate, approve, enforce and analyze the NRS Prospecting Plan
 - review and approve individual travel itineraries and school canvassing programs
 - conduct daily production reviews with each assigned recruiter
 - maintain, approve and revise the station planner
 - ensure applicant logs are complete, accurate and up-to-date

- ensure assigned recruiters use approved LEADS and Appointment Power Phone/PDC scripts
- Selling and Processing. The RINC is the sales expert and recruiter's primary trainer. He personally observes and critiques each recruiter's sales technique. He manages his station's DEP and keeps a database of QNE's. The RINC must conduct most of the administrative processing. He writes evals and fitreps, leave and special request chits, and awards. He interviews all applicants requiring a waiver and is typically responsible for calling LEADs and setting up interviews.
- Administration. The RINC has a long list of administrative responsibilities. Among them are:
 - File names, addresses and phone numbers of assigned NRS personnel with local police and fire departments
 - Ensure completion of delegated logs and reports by subordinates
 - Dispose of testing materials per current directives
 - Supervise office routine
 - Draft outgoing and review/follow-up on incoming correspondence
 - Handle inquiries (Red Cross, dependent, military on leave, Authorized Without Leave/deserters and others as required)
 - Authorize domicile-to-duty vehicle use for assigned recruiters
 - Sign custody cards for accountable inventory and conduct periodic inventories
 - Establish NRS working hours
 - Ensure adherence to and monitor the DEP leadership program
 - Recommend fault/no fault transfers, medals and other awards

The largest single group of personnel in the command are the Enlisted Recruiters. Recruiters are responsible for providing a "sufficient number of qualified civilian applicants for Navy enlistment." A command's recruiting complement can number from the low 80's to over 200 for some large districts.

Recruiters are fleet sailors (E-4 to E-8) who may or may not be coming off operational duty on a staff, ship or squadron. They undergo rigorous sales training at the Naval Recruiting Orientation Unit (NORU) in Pensacola, FL. The training lasts five weeks. After approximately 3 to 6 months in the field, the recruiters are then sent back to NORU for refresher training.

Recruiting duty is shore duty for these fleet sailors. It may or may not be voluntary duty, depending on the detailer's needs. Recruiters can request specific NRS' within a district by contacting the CR prior to reporting to the command. The potential recruiters can call from their departing command or from NORU during training. Many districts require that the recruiter fill out a biography and preference form in order to make a better choice of placement.

Once in the NRS, recruiters are usually assigned a specific geographic area within the bounds of the NRS' territory. These areas are normally separated by zip codes. Recruiters may not always get the NRS assignment they requested. It is up to the command to determine whether or not to move assigned recruiters.

The specific duties of recruiters are outlined below:

- Prospecting. Recruiters must continuously search for prospects using all available resources and make appointments by developing contacts via telephone, leads, referrals, personally developed contacts, school visits and travel itineraries.
- Processing. Recruiters prepare pre-enlistment kits. They also process, schedule and drive applicants to the MEPS. Recruiters brief the applicants on processing procedures and handle/counsel applicants who successfully and unsuccessfully process for enlistment. Recruiters also train the DEPpers, tracking their PQS and physical training.
- Marketing. Recruiters identify target market population (assigned territory boundaries, location and quality of educational institutions, population centers³⁶, and leisure time activity centers such as youth centers and fast-food restaurants. They also make optimum use of district resources and use community personnel resources such as educators, local government officials, media representatives, community service organizations and Recruiting District Advisor Councils.

(3) Military Entrance Processing Station Liaison (MEPS Liaison). The person in charge of the MEPS Liaison is the Enlisted Processing Division Supervisor (EPDS). Whereas the CR supervises the enlisted *production* function of the command, the EPDS directs the enlisted *processing* function of the district. Like the CR, the EPDS works directly for the Enlisted Programs Officer. The EPDS manages and

³⁶ Population centers include metropolitan areas, cities, towns, unincorporated towns.

supervises the processing of qualified applicants for enlistment. Most of the EPO's enlisted processing procedures are conducted and coordinated by the EPDS.

The EPDS can be a civilian civil serviceman, usually at the GS-9 to 11 level, or an active duty First-Class, Chief, Senior Chief or Master Chief Petty Officer. The EPDS' areas of responsibility, as outlined in CNRCINST 5400.1, are as follows:

- Administration
 - Maintain liaison with CNRC (including RQAT³⁷/Regional Command/NRD/MEPS personnel)
 - Coordinate indoctrination of newly assigned support and recruiting personnel
 - Supervise and monitor office routine (daily work, process special and recruiter inquiries, respond to irregularities, malpractice and congressional inquiries)
 - Provide information to the EPO concerning daily processing events
 - Ensure proper retention and maintenance of DEP records and residual files at the NRD
 - Ensures the MEPS production evaluation reports are submitted to the EPO
 - Attend Zone/NRD Production/planning and training meetings
- Training. The EPDS is responsible for the training conducted at the MEPS. He also submits inputs to the command's annual Training Plan. He must also implement the CNRC and district training plan.
- Resource Management. The EPDS ensures that quality control policies are adhered to by his subordinates at MEPS, as well as the recruiters in the field. He monitors pre-enlistment waiver and non-waiver kits for completeness and accuracy. He monitors program (such as Nuke and AECF), shipping, DEP, RTC level loading, mental quality and other assigned goals.

One of the key players on the MEPS team is the MLPO, or MEPS Liaison Petty Officer. He or she coordinates pre-qualification processing and is the final "quality control" checkpoint of applicants prior to actual enlistment or reenlist into the United States Navy.

³⁷ RQAT is the Recruiter Quality Assurance Team (a group of Career Recruiting Force that works for CNRC) located at RTC Great Lakes who interview recruits to determine if any recruiting irregularities.

The MLPO is usually an E-5 or above, assigned by the EPDS. His or her primary mission is to maintain liaison between the MEPS Navy liaison office and the MEPS itself. He or she is also the primary liaison between the recruiters and the MEPS Navy liaison office.

The MLPO is also responsible for the following elements of processing:

- Ensures smooth flow of processing (scheduling, transportation, meal/lodging arrangements, briefing applicants on MEPS procedures, counseling DEPpers on responsibilities, counseling medical disqualifications.)
- Quality control of kits by screening them for proper basic enlistment eligibility requirements (BEERS), accuracy and completeness
- Review physical examination results of applicants
- Identify enlistment requirements (mental, medical, physical, moral, waiver, police/juvenile involvement, alcohol/drug abuse and prior military service)
- Explain enlistment obligations to applicants
- Provide MEPS with a list of Navy applicants to be processed each day

Another key figure in the MEPS liaison office is the Senior Classifier. The Senior classifier is responsible for

Counseling all applicants on Navy options available based on personal qualifications. He matched Navy needs and applicant interests to reserve school seats using the Personalized Recruiting for Immediate and Delayed Enlistment (PRIDE) System. He coordinates placement of applicants in various enlistment programs to meet District objectives.

The senior classifier is usually a Personnelman (PN) E-6 or above, with classifying experience. Oftentimes, the Senior Classifier is on his second or third tour in a MEPS. He or she supervises the classifier team and monitors the overall placement of recruits in their ratings, trying as much as possible to meet the demands of the Navy while satisfying the needs of the recruit. The Senior Classifier is also key person in the effort to make shipping goal. He or she coordinates the assignment of bootcamp shipping dates for all recruits. The Senior Classifier should have a good idea of how many recruits the command needs to send to bootcamp in a particular month.

The other key MEPS personnel are:

- Classifiers. Supervised by the Senior Classifier, classifiers are usually Personnelman (PN). In general, their primary mission is to assign the recruits their ratings and their bootcamp shipping dates. They generate and evaluate pre-approach “blue-print”³⁸ information to discover want, needs and “Dominant Buying Motive (DBM).” They conduct sales interviews tailored to these wants, needs and DBM’s. Classifiers also identify and meet program, shipping, DEP RTC level loading, mental quality and other assigned goals and their priorities. They place recruits to meet these priorities.
- Processors. Like classifiers, processors can be Personnelman (PN’s) ordered to the MEPS. They can also be recruiters who for whatever reason, are not in the “field” as active recruiters. Processors are the primary screeners and quality control of enlistment kits and ensure that they are accurate and complete.
- Waiver Coordinator. The Waiver Coordinator can be a processor, classifier or recruiter assigned from the field. He is responsible for “the quality control review, tracking and processing of all applicant waivers.”³⁹ Applicants can receive waivers for a variety of reasons, including criminal history, drug use, medical irregularities, and prior service. The Waiver Coordinator tracks and coordinates these waivers.

3. Major Processes and Subsystems

a. Goals and Goaling⁴⁰

Goals begin with End Strength requirements as determined by congress. End Strength is the available inventory of military personnel. It represents the number of personnel required, by law, to be in the military as of October 1st of the fiscal year. End strength does not take into account those personnel who are in a “hold” status, which include such personnel as prisoners and those on medical hold.

Accession requirements are derived from end strength. The Chief of Naval Personnel derives the Accession Plan from the Strength Plan. Each year, the recruiting districts are required to send a specific number of accessions to bootcamp. The accessions assure that the Navy meets its End Strength goals for the year.

³⁸ Applicants are “blueprinted,” meaning the recruiter obtains basic information such as height, weight, job history, job preference, school experience, criminal history (if any), etc...

³⁹ CNRCINST 5400.1F.

⁴⁰ Adapted from NORU EPO course presentation “Introduction to Enlisted Programs”.

The accession goals are assigned as yearly goals to CNRC by CNP, then broken down into monthly goals. These yearly and monthly goals are then distributed to the four regions, which are then split up into the districts. Each district then, has one yearly and twelve monthly accession, or “shipping” goals.

In 2001, the Navy’s yearly accession goal was just over 57,000. That is, the Navy had to send 57,000 new recruits to boot camp. Accession goal is also known as “shipping” goal. “This is the hard goal, the goal that counts.”⁴¹ If CNRC does not make this goal, then the Navy has failed to “make goal.” Failure to make goal results in the Navy not having enough personnel to fill billets and meeting end strength. As well, not making goal brings a psychological sense of failure and the requisite internal and external bad press both internal (within the Navy) and external (the national news).

The yearly accession goal is distributed among the 31 districts according to a variety of factors such as market share, demographics, and historical performance. The annual CNRC and district goals are then divided into 12 monthly goals. Each district is responsible to make these monthly goals. For example, NRD San Diego’s average monthly goal might be 220. That is, San Diego must ship 220 members of its DEP pool to boot camp each month. Otherwise, that district has failed to make shipping goal that month. Each district’s progress is tracked publicly in CNRC’s “One Navy” report, which is e-mailed to each member of Navy recruiting every morning. Shipping goal is not considered an optional goal. Districts are expected to make this goal.

Each district must therefore send a required number of accessions to bootcamp each month. These accessions are derived from the district’s Delayed Entry Program Pool, or DEP Pool. DEPs are civilians who have signed up for the Navy as “New Contracts.” To build up DEP pools to make shipping goals, each district is thus assigned a New Contract Objective (NCO) each month. In fact, each district is assigned an annual NCO “goal”⁴².

NCOs are distributed in accordance with market factors of each district. These market factors include demographics, historical performance, Department of

⁴¹ Commanding Officer NRDSO, August 2001.

⁴² Although “NCO goal” is redundant (NC Objective goal), it is an accepted phrase in recruiting.

Defense population and target population. Each district is assigned a “fair” goal as determined by thorough analysis conducted by CNRC. For this reason, sparsely populated districts such as Omaha will have a much smaller NCO and shipping goal than that of largely populated districts such as New York. As well, demographically diverse districts such as San Diego will have a greater variety of minority-category goals than less diverse commands such as NRD Denver.

New contracts will be assigned a rating and a shipping date. The “DEPper”, as the applicant is now called (since he/she belongs in the DEP pool), now counts towards the shipping goal of the month he is assigned to ship. He or she could ship out during the month he/she “DEPs”⁴³ in, or the next month, or eleven months later. If he or she ships out in the month he/she DEPs in, then he/she counts for both the NCO goal *and* shipping goal for that month. DEPpers can stay in the DEP pool for a maximum of 365 days.

b. DEP Management

The command can change a DEPper’s shipping date to a later one (roll-out) or earlier one (roll-in). These changes depend on the command’s needs, the DEPper’s needs, or both. For instance, the command may need a shipper to ship out this month in order to make goal, but does not have enough people in the DEP pool to do so. The command may find a DEPper who is leaving in a later month to roll-in to this month in order to make goal. Conversely, the DEPper may need to attend to personal business or finish up some educational requirements and will not be able to ship out this month. Therefore, he or she requests a roll-out of his shipping date in order to take care of his business. If the command, however, cannot make goal without this DEPper, the request may not be approved. However, if the request involves such required criteria as education and/or weight loss, the command has no choice but to roll-out the DEPper, or attrite him. An attrite is a DEPper who is no longer qualified or no longer desires to join the Navy. They attrite for reasons such as being overweight (there are different standards for weight for DEP-in vs. ship out), criminal or medical information that was kept hidden, and pregnancy.

⁴³ Refers to the act of signing up for the Delayed Entry Program.

DEP Attrition (Attrites and roll-outs) have detrimental effects on NCO and shipping goal. Attrites and roll-outs that occur within the month (and shifted to outer months) have to “made-up” by the district. For example, if a district has an NCO goal of 200, and they have 20 attrites and 20 roll-outs, their goal essentially rises to 240. As well, if any of these “losses” are in month, then the shipping goal has to be adjusted accordingly. Roll-outs for DEPPers in the “out-months” do not have to be “made-up” in the current month. Out-month attrites, however, still have to be made up in the current month.

Moreover, DEP attrition is a major source of concern not only for recruiting, but for the Chief of Naval Personnel. Losses from the DEP pool which are not replaced in a timely manner result in the loss of precious boot camp seats. These seats, because they exist for only a short period of time, cannot be recovered.

For this reason, the CO is responsible for conducting DEP audits when trends show adverse conditions. These conditions include high attrition, excessive roll-outs and high RTO’s. RTO’s are those DEPPers who “Refuse to Obligate”, meaning that they simply do not want to go to bootcamp. DEPPers RTO for various reasons, such as lost interest, found another job, cold feet, or pregnancy.

c. Training

The command is responsible for implementing both CNRC’s general training policy and plan, and the command’s tailored training plan. The command may have a Training Officer who is has overall responsibility for training. As well, each command has a District Trainer who is responsible for coordinating both plans in enlisted programs. The District Trainer can also conduct the training, although the RINCs and Zone Supervisor provide the majority of training to the recruiters. Included in the training plan is required PQS for recruiters, RINCs and Zone Supes. As well, refresher training at NORU is also required. Finally, time must also be set aside for rating training and study.

d. Administration

The Chief Administrator is responsible for the district’s administration. The enlisted programs department, however, has a significant administrative workload. For that reason, there is usually a Personnelman (PN) or Yeoman (YN) assigned to the

EPO who helps solely with enlisted program administration. The CA and his admin department serve as the primary liaison with the local Personnel Support Detachment, something the EPO YN does not do. However, the EPO YN and EPO will process the majority of the command's leave and special request chits, evaluations and fitness reports, various types of correspondence, logs and reports.

e. Prospect to Contract to Recruit⁴⁴

The recruiting process occurs in five broad steps: prospecting, processing and classifying, entering the applicant in the DEP, managing the applicant while in DEP, and finally, sending the applicant to bootcamp.

(1) **Prospecting.** The recruiter can prospect his market through various methods. The first method is through leads. Leads can be local or national. Another method is referrals. Recruiters ask their current applicants to give them names of other civilians who might be interested in joining the Navy. Referrals can also come from civilian and military members of the community, members of the command, and relatives of DEPpers. The recruiter can also make telephone calls to prospects. Some school districts distribute phone lists of their students. Recruiters call this form of prospecting "phone-power." The recruiters can also visit schools to meet potential applicants. Recruiters can also obtain telephone numbers and referrals from personally developed contacts (PDC's). These are contacts that the recruiter finds by walking or driving around his market. In fact, "PDC'ing" is what the recruiters call their activity whenever they go out and try to meet prospects.

(2) **Processing and Classifying.** Once the recruit finds an applicant, he determines, through "blueprinting" and document verification, if the prospect meeting basic enlistment eligibility requirements (BEERS). These requirements include age, education, and criminal criteria. If eligible, the recruiter takes the prospect to the Military Entrance Processing Station (MEPS) which administers mental, physical and moral testing. The applicant takes the Armed Services Vocational Battery (ASVAB), if he/she has not already done so, receives a full physical, and undergoes a background check.

⁴⁴ Adapted from NORU EPO Course presentation "The Recruiting Process".

If the applicant passes all these tests, he/she goes through the classification stage of processing. DEP-in procedures vary with each command, although the basic steps of processing, MEPS testing, classifying and swearing in are standard with each MEPS. How efficient they perform these steps is crucial to how many contracts the MEPS can process in a certain period of time⁴⁵. Classification involves receiving a rating assignment and a shipping date.

(3) DEP In: Entering the Delayed Entry Program. Successful applicants enlist in the Delayed Entry Program (DEP). As mentioned, these DEPpers are now in the district's DEP pool, which count towards the command's shipping goal. Although they take an oath, they are not actually members of the military until they ship out to bootcamp.⁴⁶ They are assigned Personnel Qualification Standards, which, upon completion and coupled with a successful PRT score, results in immediate advancement to E-2.

(4) Managing the DEP pool. In addition to providing PQS, the DEPpers are also given training to help prepare them for bootcamp. Monthly and sometimes weekly DEP meetings are held by the RINC. The recruiters are responsible for accounting for their DEPpers and ensuring that their interest in the Navy is maintained throughout their entire time in the DEP pool. Recruiters can also arrange for tours of military installations, if available.

At the district level, attrition is watched closely by the CR, EPO and CO. A DEP Coordinator is usually assigned to manage attrites and roll-outs. The DEP Coordinator may also be involved in coordinating district-wide DEP training, or command DEP activities. Some districts hold such events as DEP Olympics, pitting zone DEPs against each other in friendly athletic competition.

(5) Shipping: sending the applicant to bootcamp. The final step in the recruiting process is to ensure the DEPper ships out to bootcamp. The recruiter drives the DEPper to MEPS on the morning of the shipping date, or to a

⁴⁵ Daily, weekly and monthly numbers of contracts can depend on how efficient and effective the MEPS and MEPS Navy Liaison Office are with their processing function.

⁴⁶ For this reason, the DEPper can actually drop out of the DEP without any real negative consequences. That is, a civilian employer will never know that the person dropped out of the Delayed Entry Program. However, if the DEPper decides to apply for the Navy or any armed service again, the fact that he attrited from the DEP program will probably have a negative effect on his chances for re-entering.

designated hotel or motel near the MEPS the night before the shipping date. If the applicant is driven to the hotel the night before, he takes a command bus to the MEPS the next morning. On that day, the DEPper takes the oath of enlistment and is officially a member of the United States Navy. See Figure 2.4.

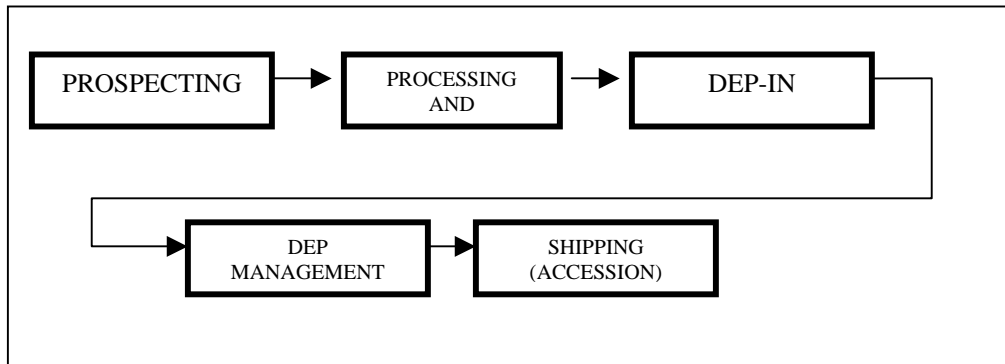

Figure 2.4. Prospect to Contract to Accession.

f. Education Verification

Basic Enlistment Entry Requirements (BEERS) state that all applicants, except for a small percentage, must have or working towards a high school diploma. The EDSPEC is responsible for ensuring that these applicants have the proper documentation. For those applicants working towards a diploma in either high school or an alternative school, must present a “Will Grad”⁴⁷ letter to the EDSPEC which clearly states the date on which the person is expected to graduate. Will Grads are extremely important when the student is attending an alternative school, such as an adult school or Job Corps. The EDSPEC is the only person on the staff who can recommend approval of these alternative programs.

The EDSPEC is also responsible for determining the last level of education received by the applicant, if the applicant is a non-high school grad (HP3’s). Education Verification (EDVER) forms are also used for education level determination.

The physical process of verifying education involves five individuals. The recruiter must obtain the applicants’ documentation (transcripts, diplomas, EDVER) and

⁴⁷ A letter signed by the student and school official stating the approximate date of graduation.

send them, in some way, to the EDSPEC. The EDSPEC then reviews the documents and, if approved, forwards them to the Commanding officer for final approval. After final approval, the documents must then be forwarded to MEPS and placed in the applicants' kit, or record.

Districts perform this process in different ways. Because of the geographic dispersion of some districts, the actual paperwork is not usually seen by the EDSPEC. Instead, faxes of the documents are sent to the EDSPEC, who signs them, sends them to CO for approval and sends them back to the recruiter. EDVERs are required to be in the applicant's kit one day prior to processing. Missing or delayed education verifications can delay an applicant from entering the Navy.

g. Waiver Processing

Applicants may have some mitigating criminal or medical issues which would normally disqualify them from service. However, many of these issues can be waived. Districts process these waivers differently. In all cases, the Enlisted Programs department writes the waivers, which are then reviewed and either approved or endorsed by the Commanding officer. Those waivers that cannot be approved by the CO, such as major felonies, large numbers of dependencies, and medical issues, are then forwarded to CNRC. CNRC processes the criminal and dependency waivers directly, while a representative from the Navy Bureau of Medicine (BUMED) processes the medical waivers. Of course, CNRC tries its best to review and approve/disapprove the waivers in a timely manner. In some instances waivers can be returned the same day. However, most of the time it takes anywhere from two to five weeks to receive a decision on a CNRC level waiver.

THIS PAGE INTENTIONALLY LEFT BLANK

III. MODEL RESULTS

A. DATA REVIEW

The data used in the model were derived from approximately 72 interviews conducted with personnel from fiscal years 97-98 and fiscal years 99-00. Although a specific protocol was employed for most of the interviews, the questions were tailored to the individual being interviewed. The data gathering process began in November 1998 and ended in November 2002.

B. SYSTEMS MODELS COMPARISON: NRD SAN DIEGO (1997-1998) AND (1999-2000)

The following models describe the (NRD San Diego) basic organizational information for the systems in effect during fiscal years 1997-1998 and 1999-2000.

1. Inputs

a. Context and Environment

Of CNRC's 31 districts, NRD San Diego has one of the largest populations. The district's area of responsibility encompasses parts of three states: southern California, southern Nevada and western Arizona. The major counties in the district include Clark in Nevada and Orange, San Diego, Riverside, San Bernardino, North San Diego and East San Diego in California. The district's major cities include San Diego, Las Vegas, Yuma, Chula Vista, Riverside, Oceanside, Anaheim, Escondido, San Bernardino, and Henderson, Nevada. Figure 3.1 shows the geographical area covered by NRD San Diego.

NRD SD is greatly influenced by its external and internal environment, resources, geography and historical performance. The social environment of the city also affects NRD San Diego. San Diego is often referred to as a "Navy" or "Fleet" town because of the many Navy and USMC bases and installations located in the county. According to the recruiters, a fleet town is perceived as having both positive and negative effects. As one recruiter put it,

The bases are a definite advantage...The district can take kids on tours of ships and squadrons at almost anytime. But you have to remember, there's a lot of military out here, so for every one ex-sailor or active sailor

that supports the Navy, there may be one disgruntled sailor who can turn a prospect against you.⁴⁸

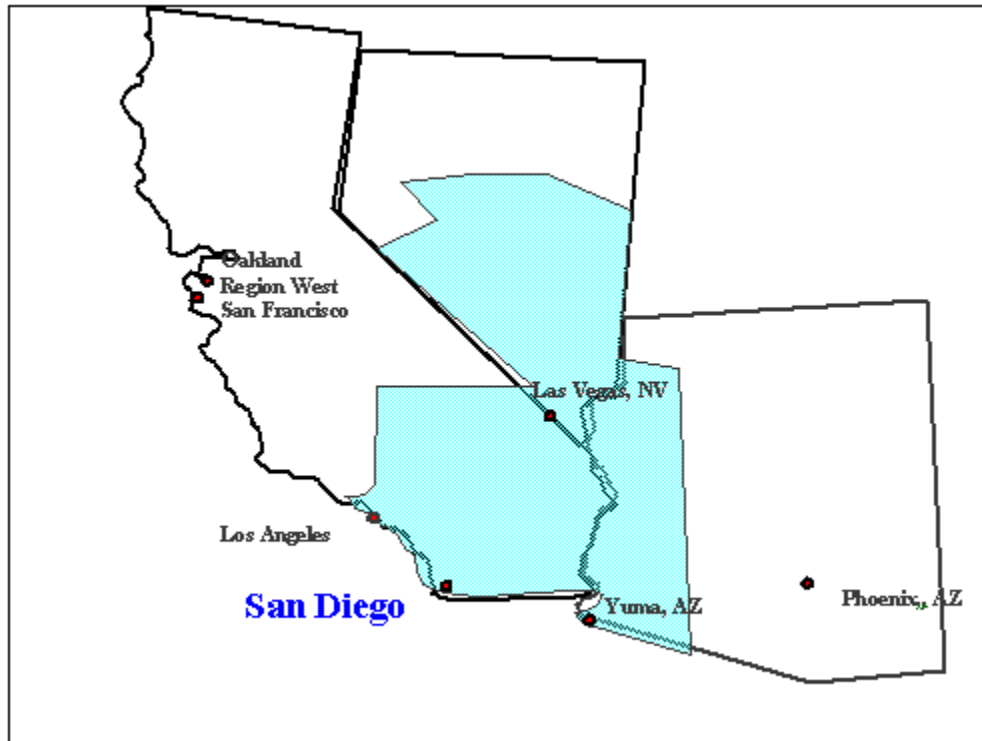

Figure 3.1. Navy Recruiting District San Diego Area of Responsibility.

Each year, NRD SD sends recruiter representatives to the Marine Corps Air Station (MCAS) Miramar Air Show, the Navy Fleet Week Celebration, the Naval Air Station El Centro Air Show, Naval Station San Diego Surface Line Week Competition, and the Naval Air Station Riverside Air Show. The 99-00 district went a step further by coordinating and hosting what became an annual Job Fair at Naval Station San Diego, and recruiting cruises on the USS CONSTELLATION CV-64 (which drew over 3000 participants) and two cruises on the USS FITZGERALD DDG-62.

Another aspect of the social environment that has an impact on NRD SD is the cultural diversity of the district. The district has a large representation of Latino, Filipino, Indo-Chinese, Japanese, African-American, Middle-Eastern, Indian, and Caucasian races. Because of the cultural diversity, the recruiters are oftentimes assigned

⁴⁸ Recruiter and Region West Recruiter of the Year, December 2001.

to their stations based on their race and language ability. For example, National City, a market filled with Filipinos, Latinos and African-Americans, had an Navy Recruiting Station (NRS) manned by four Tagalog-speaking Filipinos, one Spanish-speaking Latino and two African-Americans, while NRS Victorville, located in the high desert of San Bernardino, was manned by three Caucasians. The 99-00 NRD recruited in previously “un-mined” areas such as Santa Ana and Las Vegas, thought to be so culturally and socially diverse that they had no market. Zones 4 and 6, which were usually non-factors in District competition, suddenly became successful and productive. The 97-98 district accepted that these zones simply were not going to make goal.

Zone 6 was expected to miss every month. Too many rich kids, too many Vietnamese, too many Hispanic kids who couldn’t pass the test. So the district just relied on the other zones to make up for Orange county’s inevitable failure.⁴⁹

Cultivating these areas for success, however, was not required for the 97-98 district because the goals were lower in that era. The district could get away with riding their “horses” to make goal.⁵⁰

The cultural diversity is also a factor in determining the make-up of sub-goals assigned to NRD San Diego. San Diego is responsible to write more Latinos and African-Americans than other less culturally diverse districts. As well, because the diversity implies less affluence, San Diego has a large “Lower” market than many other districts. “Lowers” are those prospects or recruits that score below a 50 on the ASVAB.

On a broader scale, the sheer population advantage of the NRD San Diego area simply gives the district a large volume of recruits. As a result, the district receives high goals both in new contract and accessions. As well, the district has a large number of non-high school graduates (HP3’s) to choose from. The Navy mandated only 10 percent of its recruits can be HP3’s. Because it had so many non-high school graduates to choose from, San Diego often found itself depleting its quota of HP3’s very early in

⁴⁹ Chief Recruiter, July 2002.

⁵⁰ Zone Supervisor, May 2001

the fiscal year. “San Diego, if allowed, could write the entire HP3 quota for the nation in three months.”⁵¹

The 99-00 NRD had one of the strongest and most active Recruiting District Advisory Council (RDAC).⁵² Members included retired military officers, educators, politicians, and businessmen from the San Diego area. The Navy League, Sea Cadets and Veterans of Foreign Wars were also active members of the IRC. The Navy Recruiting Council (NRC) offered summer job opportunities, conducted guest lectures to the DEP and provided incentives and rewards to the recruiters for their hard work. The NRC met once a month, like clockwork, at the NRD headquarters. The CO and XO were also members of the NRC. Each year, they elected a president who was responsible for running the meetings and the NRC itself. “They are more than a liaison to the community, they’re a vital piece of this organization. They are the voice, eyes and ears of San Diego...they know what’s going on out there.”⁵³ 97-98’s version of the NRC was not as active and did not include as many public figures.

The political environment also impacts on NRD SD, especially in the public school system. Individual school districts make their own policies regarding recruitment of their students. Some school districts approve of the military, while others do not. For example, the Sweetwater Union High School District is run by a pro-military superintendent who allows recruiters to walk and solicit students on campus, he allows schools to send school lists to the recruiters. School lists have the names, addresses and telephone numbers of all the students in the school. In contrast, the San Diego Unified School District prohibits the mailing of school lists, citing that the students’ right to privacy was being violated. The 99-00 Commanding officer and Enlisted Programs Officer attended a School Board meeting to try and fight the policy but were unsuccessful. The board refused to budge.

⁵¹ Senior Classifier, June 2000.

⁵² Name changed to Navy Recruiting Council (NRC in 2001).

⁵³ Commanding Officer, May 2001.

“Some fights just aren’t worth fighting”⁵⁴ was the overall sentiment of the 97-98 NRD. The leadership had also tried to free school lists from the SD Unified School District and they too met with failure. From this experience, the district concluded that similar petitioning to other school boards by whatever method would not be successful. The 97-98 NRD had experience on their side. The leadership had some recruiting experience and realized that some ideas were not worth pursuing. To “fight” for policy changes such as school lists would just be a “waste of energy.”⁵⁵

Another aspect of the political environment is how much support the local congressmen, assemblymen and mayors give to the district. In 99-00, the commanding officer aggressively sought the support of such politicians as Rep. Duke Cunningham and Mayor Susan Golding. He managed to win their support where beforehand there was little exposure to the political arena. Members of Cunningham’s and other politicians’ staffs even joined the District’s NRC. The author received no data describing 97-98’s efforts at seeking political support.

The economic environment of NRD SD varies greatly over its area of responsibility. Some areas are very affluent, such as La Jolla, Coronado and some parts of Orange County such as Mission Viejo. Although there were a lower number of prospects recruited in these areas, they did have the potential to produce a relatively greater number of high quality recruits.

The district got a lot of Nukes and A-cells out of Coronado and Fallbrook. Those kids are usually very bright and won’t join unless they get a job with a big bonus (like Nuke) or with guaranteed (technical) training.⁵⁶

NRD SD always had great success in recruiting out of less affluent areas such as National City and Chula Vista. However, lower income areas did not guarantee inherent success. The Orange County cities of Santa Ana and Garden Grove have low median incomes, but did not share the same early success as comparable cities in San Diego County. Reasons included the language barrier and lack of strong leadership and

⁵⁴ Senior Leader, February 2000 referring to the sometimes wasted effort of trying to “fight” for such things as school lists.

⁵⁵ Zone Supervisor, March 2002.

⁵⁶ Chief Recruiter, May 2001.

recruiting ability. Santa Ana is primarily Hispanic while primarily people of Indo-Chinese descent populate Garden Grove. These areas have high populations of persons who cannot pass the ASVAB.⁵⁷

As with most government organizations, NRD San Diego is resource constrained. The budget and available personnel are limited. However, resources increased at the national level after 1998. In an effort to reach a nation-wide total of 5000 recruiters, CNRC increased the number of recruiters in the field in 1998, with NRD San Diego's field recruiters rising from 170 at the end of 1997 to just over 200 by Oct 1999. As well, the overall CNRC budget increased in 1999. A large portion of the money was used to improve and expand advertising; purchase and fund cellular phones; and to secure a 1 to 1 government vehicle to recruiter ratio. The money was also used to increase enlistment bonuses and college fund budgeting. At the local level, NRD San Diego's budget increased incrementally by about 10 percent Each year since 1997.⁵⁸

The increase in personnel was accompanied with an increase in goal. As the CR put it,

San Diego had never seen these goals before, and I didn't know where to put all these people. To add to the trouble, many of the new personnel were disgruntled non-volunteers who were forced to do recruiting. I had my hands full with trying to keep these people happy.⁵⁹

NRD San Diego has had a very successful history and outstanding reputation as a consistent producer in Navy Recruiting. The command has not missed a monthly accession goal since 1997. The legacy of the District's previous accomplishments were sustained during this study's time period by several recruiters and CRF's who had spent a great deal of their careers at NRD San Diego.

In 1997, the district made all of its monthly and yearly goals. With the dramatic goal increase in 1998, however, came problems. Although the district achieved its accession goal all 12 months, the command only made NCO goal two out of the

⁵⁷ Armed Services Vocational Aptitude Battery, a standardized test given to all recruits to not only determine which jobs fit them, but also to determine whether the applicant meets minimum requirements in Math and English skills.

⁵⁸ Assistant EPO, December 2001.

⁵⁹ Chief Recruiter, July 2002.

twelve months, and missed the yearly goal by 258 contracts! Despite being awarded CNRC's bronze award as the third best district in the nation, failing to make NCO was viewed as failure by many of the recruiters and CRF's who had enjoyed historical success. The "living" knowledge of previous success allowed the new recruiters to imagine what comprised a "successful" district. In fact, the definitions of success described in this study are derived from the descriptions and perspectives of these long-term, experienced recruiters.⁶⁰

b. Key Success Factors

The 97-98 district leadership defined three primary success factors: 1) attaining accession goal, 2) maintaining a good quality of life and 3) eliminating improprieties. Making accession goal is the primary mission of CNRC, and the leadership recognized that. There were two individuals who were central in making shipping goal, the Enlisted Programs Officer (EPO) and the Chief Recruiter (CR). The EPO was very busy conducting quality control on the DEP pool to ensure that the shippers were actually going to ship on their assigned date.

She used to call my DEPPers to find out if they were going to bootcamp. She used to call me to ask me why I rolled out a specific depper. She used to keep track of DEPPers on a little calendar she had. It was as if she didn't trust the fact that the district could take care of our DEP pools.⁶¹

The CR had to constantly monitor the DEP pool as well. Unfortunately, this detracted her from concentrating on NCO goal. As a result of this and other factors, NCO goal was not consistently achieved. "The command felt that close was good enough...after all it's not a goal, it's an objective."⁶² In general, the recruiters knew that NCO goal was important, they knew that if they didn't make it, there would be no real negative repercussions. Of the six zones, three usually made goal (2, 3 and 5) while the other three struggled to consistently make goal. As stated, zones 4 and 6 were not expected to make goal:

Las Vegas (zone 4) was accepted as being a tough zone with too many transients and too many other job opportunities. Some of the guys in the

⁶⁰ Zone Supervisor, May 2001.

⁶¹ Anonymous Recruiter, Zone 4, May 2001.

⁶² Zone Supervisor, June 2002.

zone bought into that so they didn't try that hard to recruit. Likewise, zone 6 (Orange County) was too 'rich' of an area to expect contracts. They, too, were never expected to make goal. The other zones just overwrote contracts to try and make up for the underachieving zones.⁶³

Quality of life was a major concern for the command. Recruiting is a rigorous shore duty. "It is, bar none, the toughest shore duty in the Navy," said one zone supervisor. He continued

you receive five weeks of training on how to sell people into joining the Navy. Even people who have been salespersons all their lives couldn't handle this type of sales pressure. You have to make goal every single month. The accomplishments you had previously do not matter. It's 'what have you done for me lately' that counts.

As a result, many recruiters work nine to twelve hour days, on average, to make their monthly goals. To be successful at their jobs, many recruiters sacrifice their home and social lives. Compounding the problem is the fact that most recruiters have just left arduous sea duty and expect a rest while on their shore tour.

In many districts, maintaining quality of life is the toughest challenge the command faces. The toll of making goal brings with it the almost unavoidable consequence of unhappy sailors and families. Successful districts can balance the fine line of making goal while at the same time maintaining a positive quality of life. The command realized that the field was under tremendous pressure. Therefore, the CO did not aggressively push for making NCO goal as much as accession goal. Additionally, the CO achieved great favor from the field using congratulatory handwritten notes and phone calls.

She treated us very well. She cared for us. She would buy Thanksgiving turkeys for those top-performers. She would buy food for us at MEPS during Mission Days. You could tell she genuinely cared about our well-being.⁶⁴

Quality of life in the field appeared outstanding according to many recruiters. However, the Career Recruiting Force (CRFs) did not feel satisfied. As one zone supe stated, "we, who were trained to make all goals, not just accessions, felt like

⁶³ Chief Recruiter, June 2001.

⁶⁴ Sue Lesage, Assistant Statistician, July 2002.

we weren't performing up to our potential." Quality of life in headquarters also suffered. There was a perception of "field first, headquarters last"⁶⁵ with the command. With all the emphasis on recruiting, many in the support staff felt as one staffer put it, like they were "on the bottom of the food chain."

Recruiting duty has a high potential for impropriety and unethical behavior by the recruiters. The recruiters are independent and are pressured to make goals and deal with young people every day. Improprieties may include such occurrences as:

- telling an applicant to withhold disqualifying information such as a criminal infraction or medical condition
- having sex or a relationship with an applicant or Depper
- misusing a government credit card
- forging parental consent
- generating fake diplomas, birth certificates or social security cards
- using a government vehicle for other than official business
- holding an attrite that the recruiters knows is not going (for reasons such as pregnancy, jail time, criminal activity)
- fraternization among recruiters

The 97-98 command made it very clear that recruiters involved in any improprieties would be severely punished. Recruiters were punished severely at Captain's Mast in cases of impropriety. As a result, however, anything that even remotely resembled being "dirty" was looked at with an intense microscope. We couldn't take any risks, even if the risks were legal" said one recruiter. He continued "Many of us were afraid to recruit...that's why the district consistently missed goal."

An applicant with a questionable criminal past, who could not show immediate proof of innocence was not considered for enlistment. "The district had kids who were qualified on paper, but because they could not come up with 'proper' court documents, were not allowed to process. The court documents might be sealed, or the

⁶⁵ Anonymous headquarters civilian, August 2002.

applicant needed some time to get them...when the district turned them down, they would just go to Los Angeles and process there.”⁶⁶

To add, the recruiters did not feel like making any extra effort to “go the extra mile” to bring in another contract. Since NCO attainment was not a success factor, the recruiters accepted that 90 percent was enough.

It was terrible...for those of us who knew that the district could make 100 percent every single month, this 90 percent stuff was killing us. It’s like losing became contagious. The problem was, people didn’t think that 90 percent was losing. That killed us.⁶⁷

NRD San Diego’s critical success factors underwent a change in 1999. The factors were well defined. The command now delineated four primary success factors: 1) attainment of accession goal, 2) attainment of NCO, 3) minimized DEP Attrition and 4) minimized RTC Attrition. Secondary success factors included minimized recruiter improprieties, maximized quality of life, and maximized retention.

As with the previous district, shipping goal was considered a critical success factor. As the 99-00 CO said many times, the primary mission of any recruiting district is to “put people in the Navy.” This means sending recruits to boot camp.

In fact, San Diego made every possible effort to make shipping goal each month. San Diego began each month with either a surplus or deficit in their shipping numbers. If San Diego had a surplus, oftentimes the Regional Commodore would increase San Diego’s goal in order to help the Region make its shipping goal. When San Diego’s goal went up, it usually meant that another Region West district’s, such as Phoenix or San Antonio, received a goal reduction to allow them a chance to make goal. Because of San Diego’s reputation for making goal consistently, its goal hardly ever decreased, even when it had a deficit going into the month.

⁶⁶ Recruiter, June 2001, referring to the common occurrence of applicants whom NRD SD would not process because they could not come up with court documents to explain a charge in their record. Technically, applicants can DEP in with a handwritten statement explaining a charge. NRD SD in 97-99 usually did not accept handwritten statements for fear that the applicant might not be telling the whole truth. For example, an applicant may have a charge of “battery” show up on their record. Without proper court documents, the battery charge may not clearly describe the situation with which the applicant was involved. There were many situations where a battery charge was actually a pleaded down “attempted murder” or “assault with a deadly weapon” charge; but The district would not have known that if The district didn’t have the court records to clarify.

⁶⁷ Zone Supervisor, July 2002.

The controlling element of 99-00 San Diego's shipping goal was the Military Entrance Processing Station (MEPS) Senior Classifier. The CR and EPO "delegated" the management of shipping goal to the Senior Classifier. Although the recruiters placed new contracts in the DEP pool, it was the responsibility of the Senior Classifier, and to a lesser extent, the Enlisted Processing Division Supervisor (EPDS), to place these contracts into the months that needed them most. That is, the Senior Classifier must "have a handle" on which months' DEP pools required bodies, and he thus filled those months with the new contracts as they came in. This reality was a source of some friction between the Senior Classifier and the CR. The CR believed that she and her recruiters were as much or more responsible for the shipping goal. However, it became clear that without the continuous monitoring and placement by the Senior Classifier, shipping goal would be difficult to manage by the recruiters. For this reason, the Senior Classifier had as much of an "open line" to the commanding officer and EPO as did the CR. In fact, the first person the commanding officer and EPO called each morning was usually the MEPS, and in particular the Senior Classifier. They wanted to know three things: 1) how many shippers showed up to MEPS to ship out to bootcamp in the morning 2) how many did not show up, and 3) how many new contracts were on deck.⁶⁸

Another determinant of the 99-00 NRD SD System was how often it made New Contract Objective (NCO). Although shipping goal was "extremely important, the primary focus at NRD SD was making NCO goal. In fact, the generic term "making goal" almost always applied to NCO goal. The district believed that making NCO almost guarantees making shipping goal. In fact, making NCO had other benefits, such as increased quality of life and improved attitudes.

NCO ties closely into shipping goal. Every NCO is a shipper, and thus will count towards a specific month's shipping goal once he/she ships out. Every NCO is placed into the DEP "pool" for a specific month and counts towards 1) the current month's NCO goal and 2) the shipping goal for the month in which he/she is scheduled to

⁶⁸ These are the applicants that the recruiters bring in to process for possible DEP-in.

ship. For example, SN Smith signs up for the Navy in March, but is scheduled to ship out in April. SN Smith counts towards March's NCO goal and towards April's ship goal.

A recruit can also count for the same month's NCO and Ship goal if he/she signs up that month and ships out that month. The recruit can stay in the DEP program for up to a year, which is almost always the case when the recruit is still in high school. A junior in high school who knows he/she wants to join the Navy signs up at the beginning of senior year and ships out upon graduation. He/she has thus spent that year in the Delayed Entry Program. Other reasons why recruits do not ship out immediately include 1) unavailability of ratings until a later date, 2) trying to clear something in their criminal record, 3) trying to complete their education, and 4) trying to make weight standards (you can DEP in at a lower standard than shipping out).

An NCO can be equated to an investment in the future. The more NCOs a district obtains, the larger their DEP pool and the greater their chances of making shipping goal. San Diego packed its DEP pools so well that it theoretically made future shipping goals several months early.

NCO progress is tracked on the CNRC's daily "One Navy" document and districts that achieve NCO receive a 100 percent beside their name once the month ends. Successful districts achieve 100 percent NCO every month. In sum, San Diego felt that making NCO was beneficial in several ways. For one, making NCO "makes you feel like a winner, that is it shows that you achieved an assigned goal...100 percent looks a lot better than 97 percent."⁶⁹ Secondly, it provides a monthly focus for each of the recruiters, RINCs and Zone Supes each month. As well, achieving NCO helps to make shipping goal.

Minimizing Delayed Entry Program Attrition. Another success determinant used by the 99-00 district was how well it maintained the health of its DEP pool. More specifically, San Diego believed a successful district has low DEP attrition. That is, San Diego strived to achieve low "in-month" DEP attrition relative to "out-month" attrition. In-month attrition is lost shippers that were supposed to ship during the current month. Out-month attrites are DEPPers that are scheduled to ship in later months.

⁶⁹ Chief Recruiter, August 2001.

For example, in April, SN Smith counts as an in-month attrite, because he was supposed to ship in April. If he had attrited in March, then he would be counted as an out-month attrite.

In month attrites are damaging because in the big picture, the nation loses a shipper that it thought it had that month. That is, since the loss was not identified in previous months, the nation assumes (to a certain extent) that every DEPper that is scheduled to ship in the current month is going to ship. The reason for this is that districts are required to inspect their DEP pools and determine which DEPpers are “going” and which are “not going.” Theoretically, the districts should know how “healthy” their DEP pools are at any given point in time.

A district is then urged to take more out-month attrites than in month attrites. Although this will help “clean up” the DEP pool and make it more healthy, it also forces the recruiter to replace the attrite with another contract to “make up” that out-month loss. The reason for this is because any attrite, whether out-month or in-month, counts against the current month’s NCO goal. Districts may be hesitant to take out-month attrites for fear of missing the current month NCO goal.

Another harmful effect of in-month DEP attrition is the fact that each of the DEPpers is given a specific rating assignment by the Navy. If the attrite is not identified early, that assignment or “seat” could be lost forever. This is unfortunate because some seats are tough to get and an attrite may prevent that seat from ever being used.

Finally, attrites take a toll on quality of life. Every attrite needs to be replaced by another recruit. Therefore, the recruiter must work harder to make goal. For this reason, recruiters may not openly identify attrites because he/she does not want to risk missing goal for his/herself or station.

The 99-00 NRD San Diego tried, but not always successfully, to minimize its in-month DEP attrition. In fact, “this is one area with which the district could have done better,” admits the district CO. Because they wanted to make NCO so badly, recruiters often pushed the limit with their DEP problems. Any DEP losses would have to be made up, giving the recruiters additional goal for that particular month. One

common occurrence was that recruiters “held on” to the attrites far too long. A possible attrite can be “rolled out” to another month instead of “attrited” that month in the hopes that the possible attrite will change his or her mind and ship out later on. Unfortunately, many times the recruit did not change their minds and attrited during the month in which they were rolled. They then counted as an in-month attrite for that month. Why not roll them out even longer? For one, a depper can only be in the pool for 365 days; many of these attrites were rolled to their 365th day. They could not be rolled-out any longer. They had to be attrited. Secondly, many were truly lost causes and some were just lost, literally. The district could not roll out people that, without doubt, did not want to go to bootcamp. The following describes one RINC’s sentiments about possible attrites and their effect on goal:

I would be lying if I said it didn’t happen, even here in San Diego. We’re here to put people in the Navy and we can’t do that without making goal...and if there’s a possible attrite who has a chance to be saved, then I’ll take that chance, even if that guy attrites later on. I would not risk mission for a guy that “might” attrite.⁷⁰

For all the success NRD SD 99-00 had in writing contracts and making shipping goal, it was often reprimanded by Region West for its large number of in month attrites. “We didn’t take our attrites as aggressively as we could have” stated on zone supervisor, “but if we took every possible attrite, then we would never make goal. Unfortunately some of those attrites came back to bite us.”

Although the command came under constant scrutiny for the number of in-month attrites it suffered, “as long as we continued to make goal, no one bothered us and we’ll still be the best.”⁷¹ Although this statement warranted some truth (NRD SD was recognized as Region West District of the Year in 1999 and 2000), the threat of a DEP audit by the Region or CNRC always loomed over the district. In fact, during those months where the Region was in danger of missing accession goal, San Diego was often singled out as being one of the causes because of the high numbers of attrites the district suffered.

⁷⁰ Recruiter in Charge, November 2001.

⁷¹ Zone Supervisor, June 2001.

Another determinant of success is Recruit Training Command (RTC) attrition. San Diego went beyond the traditional scope of responsibility for recruits, extending its influence all the way to bootcamp. Although districts have less control of this determinant, the training and guidance the recruiters give to the recruits prior to departure have definite impact on whether or not they decide to stay in boot camp, and thus in the Navy. NRD San Diego gave each shipper a set of motivation cards with their recruiters' telephone numbers enclosed. The recruits were told that they could always call their recruiters if they had a problem or needed someone to talk to at boot camp. The recruiters, in turn, maintained strong relationships with their recruits. "I've made a lot of good friends and shipmates as a recruiter. I try to keep in contact with them as much as possible. I think they appreciate it."⁷²

Other reasons for dropping out of boot camp may be a direct reflection of the command. Disqualifying factors such as hidden medical conditions or undisclosed criminal involvement could have been identified prior to shipping out, or even prior to DEPPing in. San Diego did not tolerate hiding disqualifying information.

RTC drop-outs are tracked by RTC and CNRC. A group of Navy counselors called RQAT (Recruiter Quality Assurance Team) also conducts interviews and a "moment of truth" at RTC. "Moments of Truth" are conducted at several stages of a recruit's processing, at MEPS during DEP in and ship out, at the recruiting station when they first walk in, and by the RQAT at RTC. During the moment of truth, the recruit is asked if they have lied or have anything to disclose prior to shipping. San Diego takes an extra step by conducting its own moment of truth at the district headquarters prior to the recruit reporting to MEPS.

The 99-00 systems secondary critical success factors are outlined next. Although these factors were important to the system, they were not considered "must haves" in order to have a successful organization:

Like 97-98, quality of life was considered a critical success factor. The key to maximizing quality of life in 99-00 was to make goal. As the CR often said, "making goal equals quality of life." In San Diego, there appeared to be a correlation

⁷² Recruiter in Charge, December 2000.

between quality of life and making goal. The CR and CO tapped the competitive side of the recruiters, using goal as a measure of winning:

We were chastised because other districts thought we were losers. As a result, we worked our butts off but were never really taught how to be successful. I'm glad we're making goal now...I can actually enjoy my job knowing I'm a winner.

As well, when the recruiters became efficient at making goal, they figured out ways to earn more free time for themselves and their family. One zone supervisor even trained his zone to make goal by working four "hard days a week, and take Friday off"⁷³ to spend however they wanted. One veteran recruiter summed it up: "life was never this good when we weren't making goal."

The 99-00 command wanted to eliminate improprieties as much as the 97-98 district did. However, 99-00 felt that previous methods of curbing illegal activity were morale busters:

Some districts just run scared. They'd rather minimize improprieties and not make goal, then let the guys recruit and make goal. That doesn't mean that the only way to make goal is through improper methods...it simply means that a scared recruiter will never make goal. Commands should not make recruiters feel scared.⁷⁴

San Diego strived to discourage these types of activities without becoming a "martial" state. The method was simple. The CO, EPO, CR and Zone Supes often put out at all-hands training, through e-mail and in written correspondence that "illegal activity simply was not done."

The method was not entirely successful. With less pressure from the command, some of the recruiters acted irresponsibly. A Chief Petty Officer paid the rent of his house with his government credit card. At least two senior petty officers were accused of having unethical relationships with women other than their wives. One recruiter was convicted of having a party at his home with both DEPpers and alcohol in attendance. And one other recruiter married his former DEPper. All of these individuals did go to mast, however, and they were all punished. Their punishments, oral reprimands

⁷³ Zone Supervisor, August 2001.

⁷⁴ Recruiter, May 2001.

and suspended sentences, received mixed reviews from the field. While a good number thought the punishments were “light” others suggested that they showed compassion for the field.

The rigors of recruiting make it a prime duty station from which sailors leave the Navy. San Diego’s retention rate during 99-00 was a remarkable 98 percent. “I believe the reason why San Diego recruiters wanted to stay in was because of the high quality of life they enjoyed while they were here.”⁷⁵ Many recruiters worked four-day weeks. Most spent more time with their families than they ever did before. Many recruiters just felt good knowing that they were part of a winning organization. “I enjoy coming to work knowing that I am actually contributing to the big picture. This job makes me want to stay in.”⁷⁶ Another incentive for re-enlistment established by the second CO was a free three day stay in Las Vegas, paid for by the Las Vegas version of the RDAC. The newly re-enlisted sailor enjoyed liberty at the Binion’s Hotel, with free meals and entertainment.

c. System Direction

In the 97-98 district, the Commanding officer used the standard method of faxing a goaling letter to the recruits to communicate the command mission. The goaling letter, written and distributed at the beginning of each month, summarized the last month’s accomplishments and outlined the goals required for this month. She also traveled out to the field extensively, not only to “keep her finger on the pulse” of the district but also to keep them informed as well. E-mail was not extensively used since the only person with access to the net were the RINCs and ZSs.

The mission statement during this era was:

To maintain fleet readiness by recruiting the highest quantity of the best quality men and women for naval service. We will accomplish our mission with the utmost honesty, integrity, and the highest standards of moral and ethical conduct.

According to many recruiters, the implied mission was “make shipping goal, try your best to make NCO. 90 percent (NCO) seemed to be okay with the

⁷⁵ Assistant EPO, December 2001.

⁷⁶ Recruiter, December 2001.

command, so the recruiters took advantage of it. There was no accountability, it seemed. If the district missed, most recruiters felt bad...but they didn't let it ruin their day.”⁷⁷

The EPO faxed her own correspondence from time to time in a letter called an EPOGRAM. It was primarily an administrative tool, but also attempted to motivate the recruiters. The CR communicated to the field through his zone supervisors. The CR did not send any correspondence directly.

The 99-00 district delineated the overall mission of the command in similar ways. The message, however, was different: **MISSING GOAL WAS NOT AN OPTION.** That is, the command will make goal, no matter what. The first way the CO set direction was through the following vision statement:

We provide success opportunities for our Navy, our Nation and most of all, world peace.

Everyone was required to memorize the vision and the CO would often ask a recruiter to repeat it. “It hit home and set up our frame-of-mind” said one recruiter.

The CO wanted to ensure that everyone knew NRD San Diego’s mission. As with the previous CO, he wrote a goaling letter each month, which delineated the specific focus for the month. One month, the district might need more shippers than usual, while other months the district might require more “A-cells” (upper mental groups). Each month’s letter was different and the CO sent it out to each recruiter via e-mail. They were essentially his standing orders for the month. Each recruiter was required to read them.

The recruiters now realized they were being held accountable for doing their jobs. In the past, if a station or zone missed their goal, they would not feel badly about it. Now, they realized that their goal was part of the larger goal. It seemed as if the recruiters took the CO’s message to heart.

The EPO followed the CO’s lead and put out an “EPO Passdown Log.” The log was an informal way for me to put out information to the field. In the “PDL’s”, the EPO briefly discussed upcoming events, admin items and requirements. For the most

⁷⁷ Chief Recruiter, November 2001.

part, however, he tried to motivate the recruiters by praising them in the most public format, besides the awards ceremonies, he had at his disposal. The EPO filled the log with stats, quotes and achievements. The EPO included both humorous and motivational stories. There was no specific time for a PDL. The EPO wrote them whenever he felt like it. Some were long others were short, but they appeared very popular. In fact, recruiters would e-mail the EPO asking when the next PDL was coming out.

One method of communication used far more frequently than the previous era was electronic mail. The CO, CR and the EPO e-mailed the RINCS of recruiting stations that were making goal, and/or the recruiters that were producing above and beyond. Like the previous CO, the 99-00 CO was famous for calling recruiting stations at all times of the day (and evening) to congratulate them, give them encouragement or just to say hi. As with 97-98, these calls were not seen as inspections but rather genuine calls to the stations from a leader that cared.

The 99-00 command also used the conduit metaphor of a ship at sea to further emphasize the CO's vision. He referred to the district as his "ship," and equated making goal to "getting the ship underway." He referred to all the command personnel as "shipmates" and called MEPS "the bridge," especially on mission days. He even preferred to be called "Captain" instead of "CO" or "Skipper."

The second Commanding officer of that time period appealed to the district personnel's competitive desire to win. His most famous saying was:

Losers quit when they are tired. Winners quit when they have won.

The quote apparently inspired many in the command to perform to their potential and became a rallying cry for the recruiters, headquarters and MEPS personnel. As one recruiter put it, "making goal was like winning a big game to us...missing was losing...the CO said it- we're not going to quit 'til we've won." The CO ended every e-mail, goaling letter and speech with the phrase. In fact, at awards ceremonies, when he concluded, the recruiters often repeated the phrase while the CO spoke it.

Not to be outdone, the Chief Recruiter was also famous for her one-liners. “The CR’s always got something wise to say,” said one zone supervisor. “Believe me, we listen,” he added. Her most famous line inspired many of the recruiters to persevere:

Whatever your mind can believe and conceive, you can achieve.

2. Design Factors

a. Tasks

What is the nature of the work as defined by NRD San Diego? In both eras, the primary task was to place qualified civilian personnel into the United States Navy. Simply put, as recruiters often say, “we put people in the Navy.” In both eras, there was significant specialization involved in the tasks assigned to the districts’ people. As described previously, the processes and functions of the MEPS personnel are vastly different than those of the recruiters. The overall level of “goal first” differed between the two eras.

In 97-98, there was no apparent emphasis on “goal first.” A zone supervisor who served in both eras stated: “The district didn’t feel like the bottom line was to put people in the Navy. This was especially frustrating for those of us who wanted to do write contracts. The district wanted to put as many people in as possible, but the overall feeling was not to take chances or overstretch our bounds...ask any of the CRF’s. The district felt suffocated sometimes. Goal definitely didn’t seem like the first priority.” The different pieces of the organization conducted their tasks without any pressing desire to work together to achieve the higher tasking.

The field’s perception did not match the 97-98 leadership position of making goal the number one priority. That goal, however, was not NCO, but accessions.

The EPO would constantly ride us about our DEppers. She wanted to make sure we made shipping goal so she questioned us constantly about our DEppers to make sure they were going to bootcamp. She would come down on us if we had a missing shipper, but really didn’t do anything if we missed NCO.⁷⁸

The 97-98 district expressed concerned about the professional development of its personnel. “Members placed studying of advancement materials

⁷⁸ Recruiter, October 2000.

above recruiting because headquarters said it was okay.”⁷⁹ As well, personal development and family time were encouraged. “We were allowed to go to school, and the CO and XO understood that we were on shore duty and had families to attend to.”⁸⁰

While development of personnel, improving chances of promotion, and being a spokesman/role-model for the United States Navy were also mentioned, the predominant feeling was that the 99-00 NRD San Diego did one thing: send qualified people to bootcamp. As the CO stated many times, “make no mistake...we are here to put people in the Navy; that’s the bottom line.”⁸¹ The task of the district was spelled out very clearly for everyone: make goal. Therefore, although each department had seemingly different taskings, they all came together to achieve the primary task of the command.

Recruiting was placed above everything else, including professional development, family and personal development. Although ample time was given for recruiters to study for exams, they were still expected to sign at least two contracts for the month. Personal development, such as school, was looked at in a positive light, for those who could handle the workload and write contracts. For those that could not, however, they were indirectly “forced to choose between school and their careers, because they were still responsible for their two (a month).”⁸² Family time, it was felt, came about as a result of making goal. Unfortunately, many families were negatively affected by the intense recruiting effort. As a result, there were over a dozen divorces or separations during the 99-00 timeframe.

b. Technology

The 97-98 district operated in an environment where high costs of new technology precluded their use. Cellular phones, scanners, and broadband internet service providers were not readily available. The primary means of communication were fax and telephone. The district was very efficient with faxes, but they were subject to breakdowns. “It seemed that at least one (of the NRS’s) or MEPS’ fax machines was

⁷⁹ Recruiter, November 2000.

⁸⁰ Recruiter, October 2000.

⁸¹ Commanding Officer, February 2001.

⁸² Chief Recruiter, March 2002.

broken.”⁸³ As well, many documents were time-late, preventing contracts from being processed.

We would have to wait hours for documents like transcripts or court papers to come through. If the district didn’t get them before (MEPS) cutoff time, those guys didn’t get in. It’s a shame because sometimes those contracts were on Mission Day and they wouldn’t count until the next month.⁸⁴

Landline phones were the only telephone lines available. Some recruiters had their own personal cellular-phones but rarely used them for work because of personal cost. Many recruiters had pagers, and could therefore be contacted. If recruiters were “on the road” while they were paged, they would of course have to pull over to return the call.

When some opportunities for technological innovation became available, the 97-98 district took advantage. For example, Zone 5, the Riverside County zone, was selected as a test case for a Naval Personnel Research and Development Center (NPRDC) study regarding cellular phone use and production. NPRDC was testing whether cell phones increased production. The zone was an outstanding producer, making goal nearly every month. The recruiters could be contacted at all times of the day and could make calls anytime they needed. Although the conclusions of the study were not made available to the researcher, they may have prompted CNRC to fund cell phone use for all recruiters in 2000.

In the area of administration, all documents were written and routed on paper. DARS, Leave Chits, Special request chits, waiver requests, educational verifications, etc. were filed as paper copy. The EPO complained to her relief that “80 percent of her time” was spent doing administration. She also said that “all I ever seem to do is write evals.” Evaluations were written (sometimes handwritten) by the recruiters and zone supervisors and sent to district via duty driver or fax. The EPO had to hand-route every chit sent to her to the XO and the CO, and then send the chits back to the

⁸³ Assistant Military Liaison Petty Officer/Statistician, May 2002.

⁸⁴ Assistant EPO, May 2002.

recruiter. "Leave chits took too long to process. A lot of us were going on leave without a chit because they would get lost in somebody's box."⁸⁵

Evaluations were also processed on paper, and were sometimes late. Not only did the EPO have to re-write the evaluations, she had to convert each of the evaluations into computer format, and route them to the chain of command. She then had to re-write them with CO and XO chops and send them back to the field for signature. Once the evals got back, she then had to mail them. "The district never got our evals out in time. We were lucky if the district got them out a month late. The system was so slow."⁸⁶

Another possible area for technological improvement was statistics. The statistician would have to, one by one, type in the statistical results of each day. This was time-consuming after large volume processing days, such as working Saturdays⁸⁷ and mission days. As a result, the statistician often stayed late, and sometimes had problems getting the stats out to the recruiters in a timely manner. When inputs were finished, the stats were faxed out to the zone supervisors and recruiting stations.

DEP changes were recorded on documents known as DARS, or Delayed Entry Program Activity Reports. The district wrote and routed DARS on paper. As well, DARS were filed away in large stacks for reference purposes. Like other paper documents, the DARS were sometimes lost or delayed. Unlike other documents, however, DARS have an immediate impact on production. DARS are the means by which the command maintains an accurate picture of their DEP pool. If a DAR is missing, the accountability of the DEPper is compromised. This could result in missing Shipping and/or NCO goal.

The 99-00 district made a concerted attempt to use available technology to help improve their efficiency and increase the probability of success. The following are ways in which the district upgraded its technology:

⁸⁵ Headquarters Support Personnel/Recruiter, May 2002.

⁸⁶ Assistant EPO, May 2002.

⁸⁷ CNRC, MEPS, the four Regions and the 31 districts often work on Saturdays to accommodate for those applicants who cannot process for enlistment during the work-week.

(1) Video Teleconferencing. Technology helped to overcome some geographical challenges. Some of the district's recruiting stations are hundreds of miles away from headquarters and MEPS. This distance presents a problem with face-to-face interviews. By rule, the CO must conduct face-to-face interviews with those possible recruits that have criminal records, prior drug usage or other possibly disqualifying circumstances. The recruiters had to drive the applicants all the way down to the district office for each interview. The round-trip, in some cases, took eight hours to accomplish. This took a lot of time away from the recruiters and discouraged them from trying to recruit qualified, but slightly questionable recruits. The XO suggested the district use Video teleconferencing machines instead. After all, the CO can still see their face. The CO immediately bought six new VTC camera screens and placed them in strategic areas around the district. The recruiters now drove far less distances and spent more of their time either recruiting or with their families.

(2) LANS and Broadband. Technology made NRD SD's administration faster and more efficient. The command invested in Local LANS for each recruiting office, and fast modems instead of slow dial-up. Even though it was time-consuming, the district conducted extensive training on computer basics to the crew.

(3) Electronic Administration. The EPO delegated the responsibility of evaluation and fitness report processing to his EPO administrator, a YN1. An expert in organization, she, with help from the Assistant EPO, developed an effective timeline for writing, revising and mailing evaluations and fitness reports. She set the due dates, conducted eval writing training with all the recruiters, and delineated a list of acceptable bullets for each level of proficiency (5.0, 4.0 etc...). This way, all they had to do was cut and paste bullets and fill in names. The results were incredible. The first cycle of evals after instituting the evals was the First Class Petty Officers. The district was two weeks early. Late evals were the norm for NRD SD before our new system was in place.

Leave and special request chits were another area in which the 99-00 district improved using electronic media. Fortunately, the Statistician, a Quartermaster by rate but EXCEL wizard in his spare time, developed all the electronic forms for the district. He also sent many recruiters their electronic signature, which they

could easily affix to the chits through cut and paste methods. As well, he devised an efficient routing procedure through the e-mail, which included a built-in tracking system. The tracking system allowed everybody in the chain to know exactly who had the chit last. Chits were never lost as they were automatically saved when transmitted to an electronic inbox.

There is certain paperwork exclusive to a recruiting command. Two such documents, Depper Activity Reports (DARS) and Waiver Requests, have a tremendous impact on making goal. If these documents are held up in any manner, they could mean losing dozens of contracts each month. The reasons these reports get lost are typical of “normal” paperwork: they get lost in somebody’s inbox, they get lost in the fax machine, or they just simply “get lost.” These documents were also made electronic and all but eliminated these documents being lost.

Other administrative processes that turned electronic included vehicle usage logs and Training reports. Two items that directly improved morale and quality of life was the electronic processing of Out of Pocket Expenses (OPE) and Supply Requisitions. Recruiters receive reimbursement of up to \$75.00 on any expenses incurred while doing their jobs, such as buying a recruit lunch or paying for parking. OPE used to take up to three months to be processed. With electronic processing, the recruiters found the money in their bank accounts within two weeks. Supplies were never short as electronic processing drastically reduced the turnaround in orders.

(4) Statistics. The district also improved its statistics reporting process. Recruiter stats are a vital part of any competitive district. In San Diego, competition was one of the foundations of its success. Everyone wanted to see how he or she was doing in relation to everybody else. Stations and recruiters competed against each for monthly and year-end awards. They needed accurate, timely stats in order to see how they were faring against the “competition.” The Statistician programmed an interface between the MEPS computer system (PRIDE)⁸⁸ and his desktop computer at headquarters. With one keystroke, the names of the DEppers (with demographic information such as gender, ASVAB score, educational level, marriage status, etc.), shippers, and their recruiters downloaded into a statistics storage and reporting program

⁸⁸ Personalized Recruiting for Immediate and Delayed Enlistment

on the headquarters desktop computer. The information was then sent out to the field from his home computer or through the headquarters PC before 0700 the next morning. That way, each recruiter knew exactly where he or she stood in relation to the other recruiters.

(5) Kiosks. The district was given extra funding to conduct recruiting via “kiosks.” These kiosks were videogame-like machines that were placed in strategic locations such as high schools, shopping malls and public affairs events. Prospects typed their names, age, telephone numbers in the machines, which were linked via telephone line to a database kept at the command. The kiosks precluded the need for a recruiter to be at the site. They were mobile. They were less threatening. Through the kiosks, the district developed a large database of leads.

The actual effectiveness of the kiosks was debated. Although they were an exciting innovation, they were not the revolutionary breakthrough that the district and CNRC had hoped they would become. Increased man-hour requirements for recording data, delivering the kiosks and downloading information made the kiosks somewhat of a nuisance. “I would rather recruit the regular way than deal with the kiosks...they took up too much time and effort.”⁸⁹

The most effective use of the kiosks was at Navy-related events, such as Fleet Week and the Miramar Air Show. The crowd was pro-Navy and was eager to find out more information. Placing them in high schools and malls proved less effective. Although they were placed in high traffic areas, students were simply not interested in spending time on the machines. In all, the district attained less than 20 contracts while using the kiosks over a one-year time period.

c. Structure

The recruiting structure of both districts was similar. Geographically, the district was divided into six zones, with 44 stations spread out among them. The basic structure with major counties and stations are shown in Figure 3.1.

⁸⁹ Recruiter/RINC, responsible for a kiosk placed in Barstow, CA, two hours away from his recruiting station in Victorville.

Name	Major County/Area	Major Stations (NRS')
Zone 1	San Bernardino	San Bernardino Victorville Upland Fontana
Zone 2	North County	Oceanside Poway Mira Mesa
Zone 3	San Diego County	National City Chula Vista El Cajon College Grove
Zone 4	Las Vegas	Las Vegas (East) Las Vegas (West) Henderson Lake Havasu
Zone 5	Riverside County	Riverside Corona Temecula
Zone 6	Orange County	Anaheim Garden Grove Mission Viejo

Figure 3.1. NRD SD Zones.

Looking at the chain of command, the CO during the 97-98 time period was an O-5. She was promoted to Captain towards the end of her tour. The CO was a Fleet Support Officer (1700 designator) with extensive prior recruiting experience. Her Executive Officers were also Fleet Support Officers, both O-4's. Each served 18 month tours with her. They operated under the previous process, where the XO was ordered in for a tour and did not "fleet up" as they do now. The Enlisted Programs Officers were both O-3 1700's who served as Assistant EPO's for a year before taking the helm as the department head. The Chief Recruiter, for a time was a Senior Chief CRF who was standing in for the incoming CR. The incoming CR, who served for most of the time period of this study, was a female CRF Master Chief who was serving her first CR tour. She was, in fact, the only female CRF Master Chief in the Navy. She had extensive experience in recruiting in the region, having served as a Regional Trainer prior to her CR tour, and earned national recognition as a Zone Supervisor of the Year during her tour at NRD New York.

The district was essentially without a qualified Chief Recruiter in 1997. The assigned CR, a Master Chief with vast experience, left to attend the Senior Enlisted Academy. When he returned, he allowed the interim CR to continue on the job for at least five more months. "Although he claimed openly that there was no real reason to reclaim the job, most felt that there was some friction between him and the CO. That's

the real reason he didn't take the (CR) job back."⁹⁰ The interim CR was a Senior Chief Petty Officer CRF with little leadership experience. He was able to make NCO goal, however, "because the goals were so low."⁹¹

The CR then left, leaving the interim CR in place to turnover with the incoming Chief Recruiter. The incoming Chief Recruiter received a poor turnover from the Senior Chief prior to the beginning of 1998. To compound her problems, the district received the aforementioned goal and personnel increase. She also had to deal with the fact that almost half the recruiters were leaving within three months of her assuming the watch.

The overall structure of the district was the same for both eras. The district was divided into the same departments: public affairs, supply, LEADS, administration, officer programs and ADP. During the 97-98 time period, however, the district made a major physical move. Because the district was previously located at the now defunct Naval Training Center (NTC), the district moved "across the street" to a new home at the Fleet Anti-Submarine Warfare Training Center. Did the move have any impact on recruiting? According to most of the interviewed, the move had little effect on production. Here are some opinions:

We did it in a weekend...there was no impact.⁹²

We had some problems with phone lines, and faxes, and things like that...but we overcame them very quickly. No one ever came to district anyway, so it was no big deal.⁹³

We had to move all our desks, computers, files...you name it, we did it. The whole move took a couple weeks, altogether, and we still had to make goal...But it really didn't affect goal that much. We still made accessions.⁹⁴

The 97-98 command was very rigid and hierarchal. There were distinct lines of responsibility and management. At the top of every process was the

⁹⁰ Zone Supervisor, July 2002.

⁹¹ Zone Supervisor, August 2002.

⁹² Chief Recruiter, October 2002.

⁹³ Headquarters personnel, September 2002.

⁹⁴ Assistant EPO, May 2002.

Commanding officer. “From shipping, to public affairs, to training, to Out of Pocket Expenses (OPE)⁹⁵, the CO monitored everything. She had to make sure she knew everything. She held so many meetings...the poor EPO was down here almost every minute.”⁹⁶

The XO was very interested in all aspects of administration. “Every single piece of correspondence had to go through her.”⁹⁷ The XO also maintained the personnel “picture” of the district, taking care of recruiter improprieties and manning issues. The support department heads all reported to the XO directly. All their actions were screened by XO prior to being known by the CO.

The EPO seemingly followed the lead of her supervisors by managing nearly all aspects of the recruiting effort. “She stayed in her office until 2000 almost every night trying to catch up on her work. She had a pile of paperwork almost four feet high sometimes.”⁹⁸ She managed shipping goal, scheduled recruiter training, wrote evaluations and tracked leave requests.

The EPO had an Assistant EPO, a Chief Personnelman (PNC) who had 16 years of administrative, recruiting and MEPS experience, all of which at NRD San Diego. She also had a civilian secretary, who was primarily responsible for routing and filing leave and special request chits. The secretary also helped with writing evaluations and fitness reports.

The EPO relied on the CA and district Administration department to perform the bulk of her administrative processes. Her EPDS was a Chief Personnelman. As mentioned, the interim CR was a Senior Chief CRF with no CR experience.

The CR supervised a District Trainer. However, he was more responsible for scheduling refresher training and updating demographic information in STEAM, than for training. Recruiter training was conducted primarily by the CR and the zone supes.

⁹⁵ OPE was capped at \$75.00 per month. Recruiters were allowed to treat applicants to meals in the process of trying to recruit them. Recouping the money involved turning in claim forms on a monthly basis.

⁹⁶ Headquarters Personnel, September 2002.

⁹⁷ Ibid.

⁹⁸ Assistant EPO, September 2002.

The CR also managed a DEP Coordinator, who in 97-98 was a Petty Officer Second Class. His duties were limited, as well. He did not take an active part in managing the district's DEP pool. Instead, he was responsible for ensuring that the DEPPers received all their awards prior to departing for boot camp. For example, a DEPPER can earn a blue and gold Navy sweat suit for a certain amount of personal referrals. As well, if the DEPPers perform and pass a PRT and complete their DEP RQS, they are automatically advanced to E-2. It was the DEPCO's responsibility to ensure the DEPPers earned their just rewards.

The LEADS department consisted of the LTCS between two and four prior recruiters who were either on their way out of recruiting because they were at the end of their tour, disciplinary problems or less than adequate production, and one or two assigned personnel.

The Public Affairs Officer was the collateral duty of an O-4 Fleet Support Officer who was retiring in the next year.

The Administrative department was led by an E-8 CA and included a Yeoman First Class Petty Officer and one or two PN2's and PN3's. The Admin Department handled and processed all of the district's correspondence.

The Automated Data Processing (ADP) department consisted of a civilian civil service member, a designated R-TOOLS trainer, and a former recruiter who was responsible for paperwork. The department was primarily responsible for repairing laptops, and conducting training on recruiting software known as Recruiting Tools (R-TOOLS).

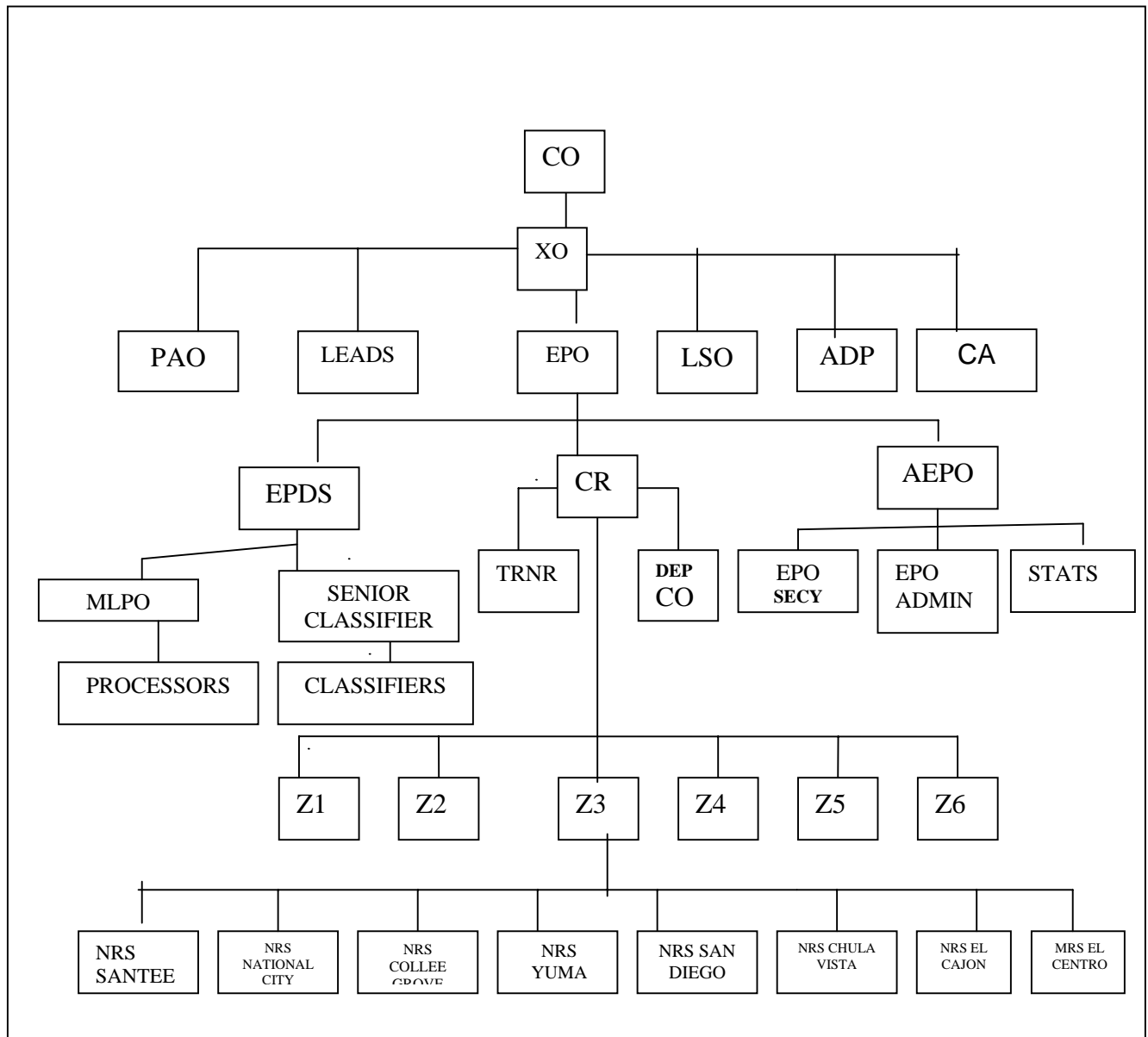

Figure 3.2. Enlisted Production Organizational Structure 97-98.

The geographic structure of the district in 99-00 was almost exactly the same as 97-98. There were six zones. Three stations closed and were replaced by three new ones. The CR and CO decided to close NRS Barstow, NRS Cypress, NRS Yucca and opened up NRS Vista, NRS Imperial Beach and NRS Del Rosa. All three new stations were located in areas that offered more of a “fruitful” market.⁹⁹

⁹⁹ Chief Recruiter, June 2001.

The organizational structure of the 99-00 district was markedly different than that of the previous era. There were two CO's during this period. They were both unrestricted line officers, one a surface warfare officer, the next a P-3 pilot. The P-3 pilot was the former XO. With current policy, the XO fleets up to CO after an 18-month tour as the second-in-command.

The CA did not exist in 99-00 as the XO and CO wrote most of their own correspondence. A Chief Yeoman led the administration department. The PAO was a Journalist First Class Petty Officer (JO1) who was very active in writing articles. He even performed as the command's disk jockey at quarterly awards ceremonies. Furthermore, the PAO department required three full-time personnel who coordinated the myriad of events that took place all over the district and maintained the local web site. The ADP (renamed SYSAD for System Administration) department employed three personnel for installation, troubleshooting and repair. Because of a new telemarketing initiative, the number of personnel in the LEADS department tripled to 12.

The Enlisted Programs Department's headquarters team included two DEP coordinators (who also served as the public affairs "strike team"). The strike team set up public affairs events such as job fairs and airshows, taking that responsibility away from the recruiters. The EPO team also added a civilian Assistant Statistician, another trainer to go along with the Assistant EPO, statistician, and two trainers.

One major change was that the EPO had a separate administrative team. The reason for a separate administrative function from the district's admin department was simply because they wanted to be intimately involved with the recruiters' administration. In other words, the EPO had to be in charge of the person responsible for the recruiters' administration. The EPO could not tell the administration department what to do; but he could tell his Yeoman what to do.¹⁰⁰ With a separate admin function, the EPO had better control over his personnel. Another major change with the structure of EPO administration was that the XO handled most issues with the *AEPO*, leaving the EPO free to handle production issues. Although the EPO still held overall responsibility

¹⁰⁰ Enlisted Programs Officer, November 2002.

for his department's administration, the AEPO was an experienced PNC who expertly conducted those duties.

As well, and most significantly, the EPO had the luxury of having an "Enlisted Processing Officer" at MEPS. Officially designated an Assistant EPO, he was an interim EPO who served in the department head position for four months prior to the permanent EPO's arrival. The AEPO was also a surface warfare officer (1100 designator) who had extensive leadership experience in the fleet. He and the EPDS worked as a team to ensure the efficient processing of applicants at MEPS.

There were also four extra processors at the MEPS who also came from the field, and a new EPDS who was a retired Personnelman Master Chief Petty Officer. The EPDS' previous civil service job was in the MEPS command, so he had the added advantage of knowing many of the personnel that worked at the MEPS.

There were additional personnel initiatives in the field. The zone supervisors each had an assistant who helped with production and administration. As well, they also had the opportunity to hire a civilian administrative assistant who also helped with paperwork.

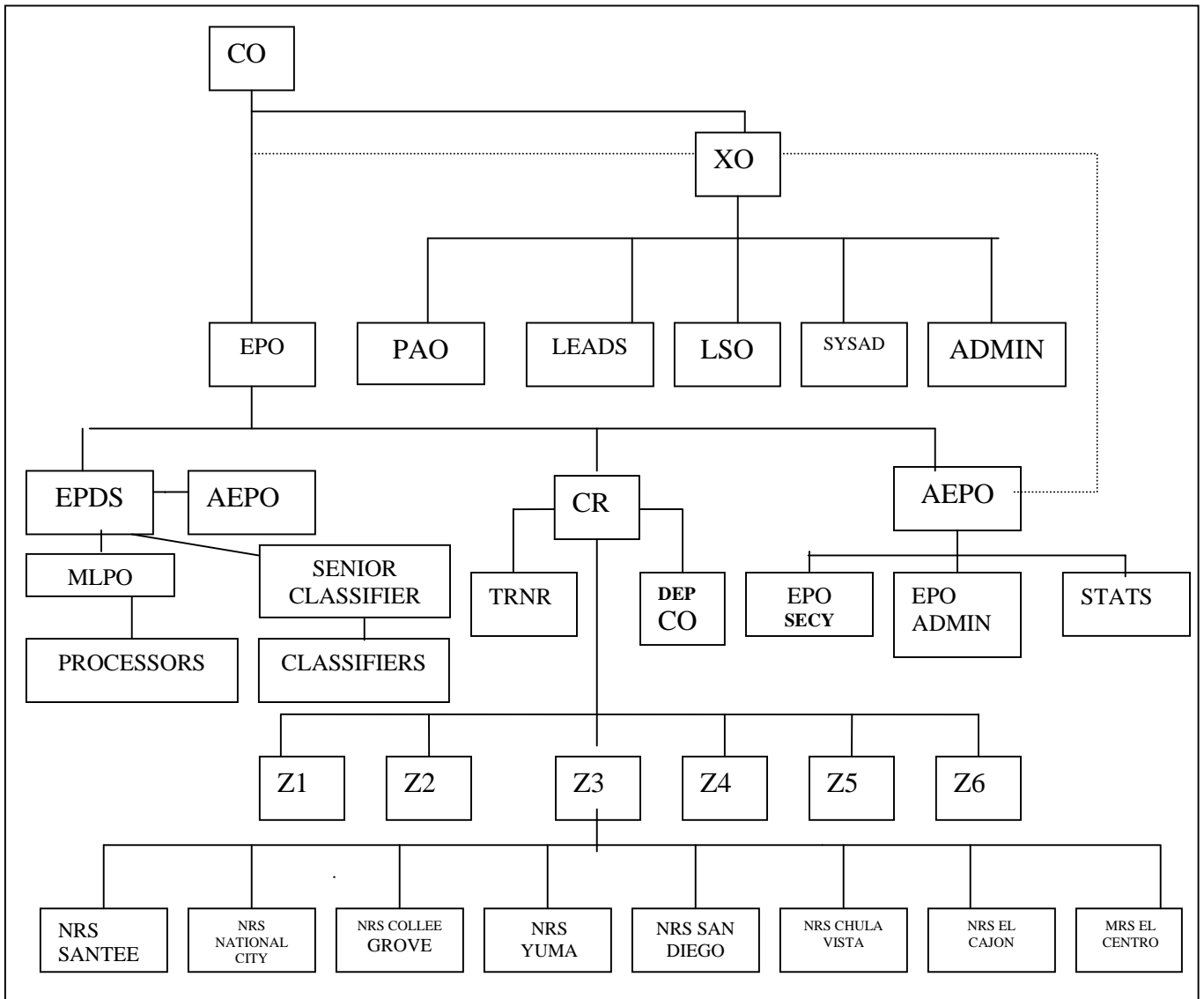

Figure 3.3 Enlisted Production Organizational Structure 99-00.

d. People

Besides the total number of personnel, the general make-up of the district was similar in both time periods. The recruiters were primarily middle level to senior level enlisted personnel. The Department Heads were all Chief Petty Officers and Junior Officers.

Traditional naval responsibilities given to rank were sometimes ignored in the field. For example, although a Chief Petty Officer might be one of the recruiters in a particular station, he or she would not be made the RINC of that station simply because

of rank. In fact, there were several stations that had petty officer second classes as the RINCs because they were simply better recruiters and in some cases, better leaders. In fact, it was not unusual to have a Petty Officer First Class Navy Career Counselor (NC1) as a zone supervisor, since precedence for these jobs was given to the career recruiter force (CRF).

The field was divided into career recruiting force (CRF's) and Fleet sailors on their shore duty tour. There was often some friction between the CRF personnel and the fleet sailors. The CRF's were former fleet sailors who changed their ratings to become full-time recruiters. As one CRF put it, the fleet sailors would "look down upon the CRF's because the district were not sea-going. I think they resented us because the district were always on shore duty and also because The district had a negative reputation for being crooks."¹⁰¹

For the most part, however, the field operated with mutual respect. The CR attempted to fill leadership positions with those individuals who were proven leaders, regardless of whether or not they were CRF. In fact, several non-CRF recruiters went on to become successful RINCs and two fleet Chief Petty Officers went on to become successful zone supervisors.

As with most recruiting districts, NRD SD also contained a mix of sailors from various communities. There were recruiters from the aviation, surface, submarine, cryptological, intelligence, supply, and personnel ratings.

As mentioned, the district (in both eras) was very racially diverse. Given the cultural diversity of the San Diego area, the racial mix was expected. Typically, at any one time period, half the field was minority with several dozen each of Filipinos, other Asians, African-Americans, and Hispanics, leaving about one hundred Caucasians.

e. Processes/Subsystems

(1) Human Resource Management. The following processes describe the recruitment and selection processes conducted by both districts:

Personnel Recruitment. As with all commands, the district has no real say in which fleet personnel CNP and CNRC assign to recruiting duty. The 97-98

¹⁰¹ Zone Supervisor, June 2002.

district did not enjoy a “steady stream” of recruiters but instead received a large number of recruiters at one time at the beginning of fiscal year 98. After the initial “jolt” of recruiters, the 99-00 district received between 5-10 recruiters per month.

With regards to the career recruiters, it seems that the CRF system allows the CRF’s to pick their preferential duty station. The CRF’s detail themselves through their own detailer, a CRF Master Chief, and negotiate their orders with greater flexibility than the fleet sailors. For example, the CR, upon leaving, had her choice of becoming a CR of another district (of her choice), CR of the nation, or an officer recruiter in another district.

The 97-98 command employed many recruiters who were non-volunteers. They were sent to recruiting because they had no other shore duty choice. As a result, many were not ready for nor wanted to face the rigors and requirements of recruiting duty. The leadership understood this and the CR, in particular, made it known that each and every person in the district was a sailor assigned to a particular duty. And as is the case in all naval commands, the sailors were accountable to do their duty, even if it was recruiting. “The message took a while to sink in with some recruiters, but once they did, they realized that they weren’t here for a vacation. They were actually here to work.”¹⁰²

As a result, the recruiters in 99-00 were experienced non-volunteers who were joined by new recruiters who, for the most part, *wanted* to come to recruiting. “As a whole, the recruiters in that time period were far easier to work with than the previous batch of recruiters.”¹⁰³

Personnel Assignment. This section refers to the assignment of personnel at headquarters and MEPS. Each department was always in need of extra personnel. The PAO, Supply, LEADS and ADP departments were all augmented with field recruiters. How did the district assign these personnel? In 97-98, the bulk of these augmenting personnel were either “failed”¹⁰⁴ recruiters or recruiters nearing their PRD’s.

¹⁰² District Trainer, December 2001.

¹⁰³ Chief Recruiter, November 2002

¹⁰⁴ “failed” refers to those recruiters, who for whatever reason (personal, social, lack of salesmanship, and/or medical) simply could not recruit, and had no potential for becoming a good recruiter. These personnel were better off away from the field.

Known begrudgingly as “District Dwellers”, these outcast recruiters were looked down upon by the field recruiters. As one recruiter put it, “it was kind of shameful to be assigned to district; it meant you couldn’t hack it out in the field.” (See Figure 3.4)

The CR, however, wanted to fill the “holes” with effective performers so as not to take away from the mission of the specific departments. She wanted to do this in ’98, but was not allowed to until ’99. She felt that “recruiters earned the right to work at district.”¹⁰⁵ This way, the district personnel would be looked upon with an air of respect. As well, the recruiters could look forward to a reward—being “off production” was something many recruiters strived for. There was some friction, however, between the CR/EPO and the XO whenever a need arose at the headquarters. The XO would want a certain person, without taking into account the individual’s turn in the CR’s “pecking order” of eligibility. There was usually debate (sometimes heated) between the XO and EPO/CR. Whatever the case, however, the spot was usually filled and the effect on production was minimized. (See Figure 3.5)

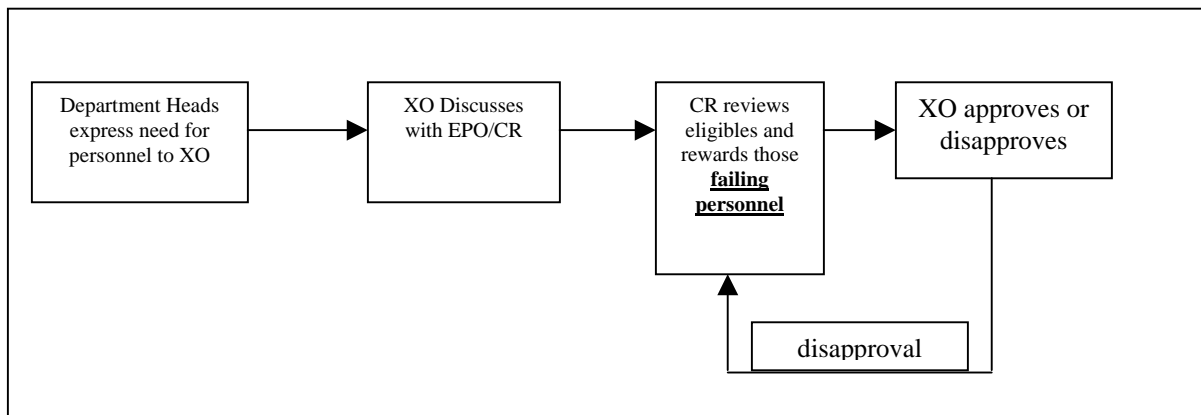

Figure 3.4. Personnel Assignment Process 97-98.

¹⁰⁵ Chief Recruiter, November 2002.

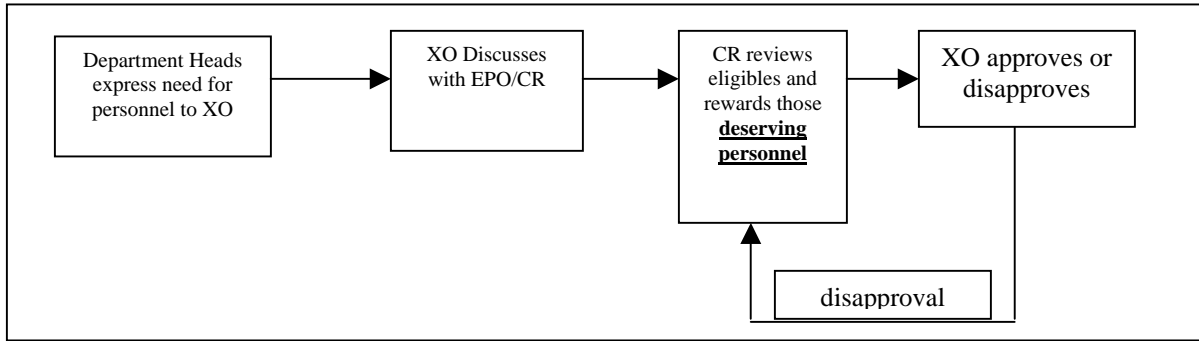

Figure 3.5. Personnel Assignment Process 99-00.

Recruiter Assignment. Assigning recruiters to their NRS' did not differ greatly between the two time periods. The first step in assigning recruiters to their particular station was a phone call by the recruiter, while at NORU, to the District Trainer. The trainer took the recruiters' preferences, but more than likely had a station already picked out. Based on inputs provided via message on the recruiters' individual background (languages spoken, nationality, familial requirements [EFM, wife's job]), the CR already had a good idea where she was going to put a prospective gain. For example, a Spanish speaker would most likely be placed in NRS Tustin, Garden Grove, El Centro or Chula Vista. However, if that recruiter had family in Arizona, the CR would consider placing the recruiter in Yuma. The CO did not have that much to do with recruiter placement. However, if a recruiter complained about his/her placement, the CO was sure to get a call.

Once a recruiter was in his/her initial station, there was still a possibility that he/she could move from that station. Once again, the CR controlled these moves with help from the zone supes. Although the XO and CO were supposed to be notified of any moves, many moves were made without the command's immediate knowledge.

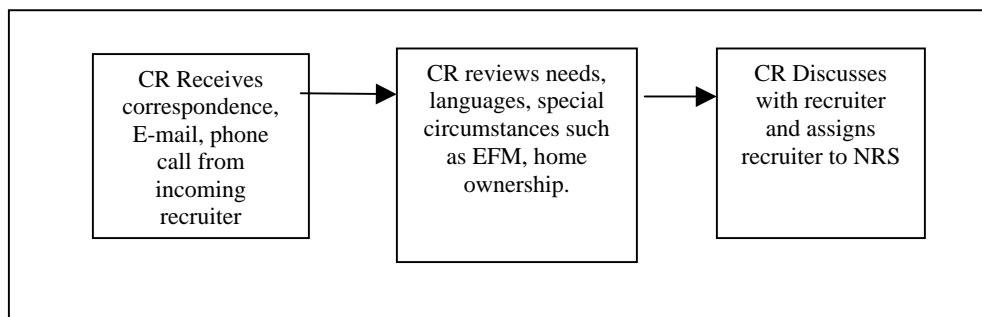

Figure 3.6. Recruiter Assignment Process 97-00.

Training. The training process was not markedly different between the two districts. Each zone supervisor was responsible for training the personnel in his/her zone. The zone supes followed a standard schedule put out by CNRC, as well as their own tailored training. The CR gave them this freedom. The zone supes took pride in providing training and were very good at it. To track training activity, the zone supes e-mailed weekly training reports to the district trainer.¹⁰⁶ On paper, the Command Training Officer, a junior officer from the Officer Programs Office, was supposed to conduct and track training. However, because she did not have any experience with enlisted recruiting, the optimum method of providing training was through the zone supes. Any other way would have caused unneeded friction between the officer programs department and the field.

Another aspect of human resource management process is the reward system. The awards and incentives system employed by the command sought to persuade the recruiters to make goal.

Awards and Recognition. One of the most effective rewards for the recruiters was a strong evaluation or fitness report. In both time periods, recruiters who were successful at NCO attainment were usually rewarded with outstanding evaluations. Unfortunately, this practice caused some criticism in the field. Some sailors who had sparkling records simply could not recruit, and were “punished” in their evals

¹⁰⁶ The title “district trainer” was a misnomer. The district trainer’s main responsibility with regards to training was tracking and scheduling; he did not provide any whatsoever. The district trainer performed other functions which were essential to the command, including: scheduling recruiter refresher and leadership training, conducting ethics and indoctrination, coordinating EPO, CR and CRF travel, STEAM management, and acting as liaison with the command Training Officer.

with low marks. On the other hand, some sailors who had average performance marks in previous commands, shined in recruiting earning them the “Early” and “Must Promotes.”

Another significant award used effectively by both time periods was the Recruiter Incentive Program, or REIP. This program was equivalent to the Command Advancement Program (CAP) used by operational commands. Sailors could be meritoriously promoted by their commanding officers if they were outstanding performers. While the 99-00 command focused its seven to nine annual REIP promotions to Petty Officer Second Class’, the 97-98 command did not restrict itself to a specific rank on who it would REIP.

The two districts handled awards in different ways. One thing in common with regards to awards was the extensive awards instruction and program used by each command. Awards were given to the “best” in several categories including individual recruiters, stations: large, medium and small categories, LEADS production, early “lock-out”¹⁰⁷, making gates¹⁰⁸, and shipping goal attainment. Production was the bottom line. If the individual, station, or zone was the top producer in New Contracts, then they earned an award. The actual awards ranged from trophies, to plaques, to pen and pencil sets. The “hardware” received was purposely large and displayable, so that the recruiters could flaunt the fruits of their efforts.

The 97-98 district CO, XO or EPO distributed awards by giving them out at the station, or at the zone level during training. The CO instituted a quarterly awards show that was modeled after the Oscars or Emmy’s. The recruits were flown or driven from their zones in order to take part. The mandatory awards show was an instant success with the field, but not so popular with the headquarters personnel. They resented having to watch “the recruiters get all those awards while we just sat there, with no acknowledgement.”¹⁰⁹ On the contrary, support personnel did earn a specific headquarters award, called the “Support Person of the Month.”

¹⁰⁷ “lock-out” means making NCO goal for the month. Locking out early means making goal a week prior to Mission Day (the last day of the month).

¹⁰⁸ The month is separated into goaling “gates”, 25%, 50%, 75% and 100%. 25% gate means trying to achieve 25% of your goal at approximately the first ¼ part of the month (might be the 7th or 8th of the month).

¹⁰⁹ Headquarters Personnel, August 2002.

Realizing the value of competition and the drive and motivation it provided to the recruiters, the 99-00 leadership continued the mandatory all-hands awards ceremonies, conducting them on a quarterly basis. The Assistant Statistician, a civilian hire who was a prior recruiter and MEPS MLPO, coordinated the program. The command held the awards ceremony in one of the six zones. The ceremony could take place near the Point Loma headquarters one quarter, Corona, CA the next quarter, and Riverside the next. For most of the field, the ceremony was not only an opportunity to receive hard-earned awards; it was also a chance to see their peers, to socialize afterwards (they were sometimes overnight events) and simply to brag about their accomplishments. The awards ceremonies ended with well-deserved recognition and increased morale and focus.

We wanted to be on that stage to get an award. It really meant something to us. Most of us felt badly if we didn't win at least one award.¹¹⁰

The command made national and regional awards something to value, but not exactly an incentive. Although the district and individuals in the district won several regional and national awards, including the top award (District of the Year) two years in a row, making goal seemed to be the only incentive the district needed to perform effectively. One zone supe summed up the impact that national recognition placed on the field:

I don't think the field, as a whole, sought to become district of the year. Although I do believe that they did not want to be the reason the district *didn't* win the award. What I mean is...everybody wanted to make goal...nobody wanted to miss...if they made goal, then there was no reason why the district shouldn't win...except maybe for politics.¹¹¹

Fitness Report and Evaluation System. The 97-98 command spent a great deal of time on processing fitreps and evaluations. As discussed, the command worked with paper and faxes with most of their paperwork. As a result, the EPO, CA and XO had to be very active in the writing, distribution, and tracking of the documents. The recruiter gave to the RINC inputs in the form of bullets, last evaluation and copies of awards and other recognition (such as certificates of appreciation from

¹¹⁰ Recruiter, December 2001.

¹¹¹ Zone Supervisor, December 2001.

schools or local businesses). Depending on the RINC, the evals were either fully written or summarily written and turned into the zone supervisor. Most of the zone supervisors wrote a complete evaluation for their recruiters based on the inputs received. The process, up to this point, could take weeks or even months to accomplish. The Chief Recruiter then received the evaluations, made her “chops” and forwarded them, by hand to the EPO. The EPO then rewrote each and every evaluation by hand, typed them up (or had her secretary type them up) and forwarded the completed evaluations to the XO. The XO edited them in hardcopy, and sent them to the Chief Administrator to make changes. The CA then sent them back to the XO, who reviewed them and returned them to the EPO. The EPO walked the evaluations to the Chief Recruiter, who sent them out to the zone supervisors. The zone supervisors then called in the recruiters and debriefed them on their marks and/or rankings. The recruiters signed the evaluations and sent them back to the zone supervisor, who forwarded them back to the EPO. The entire process sometimes took six months to accomplish. Figure 3.7 maps out the 97-98 process:

As mentioned, fitreps and evals were conducted entirely electronically in 99-00. The only time the evals were printed out was when they were ready to sign. The process begins with the EPO YN. She sent out a packet to the zone supes containing standardized bullets, each recruiter’s most recent eval and last year’s rankings. She also sent out, via e-mail, a “canned” eval, which contained the standardized bullets each zone supe was allowed to use. All this was done two months prior to the due date. For example, if evals were supposed to be postmarked by 30July to CNRC, then the EPO YN sent the eval packets out around 01May.

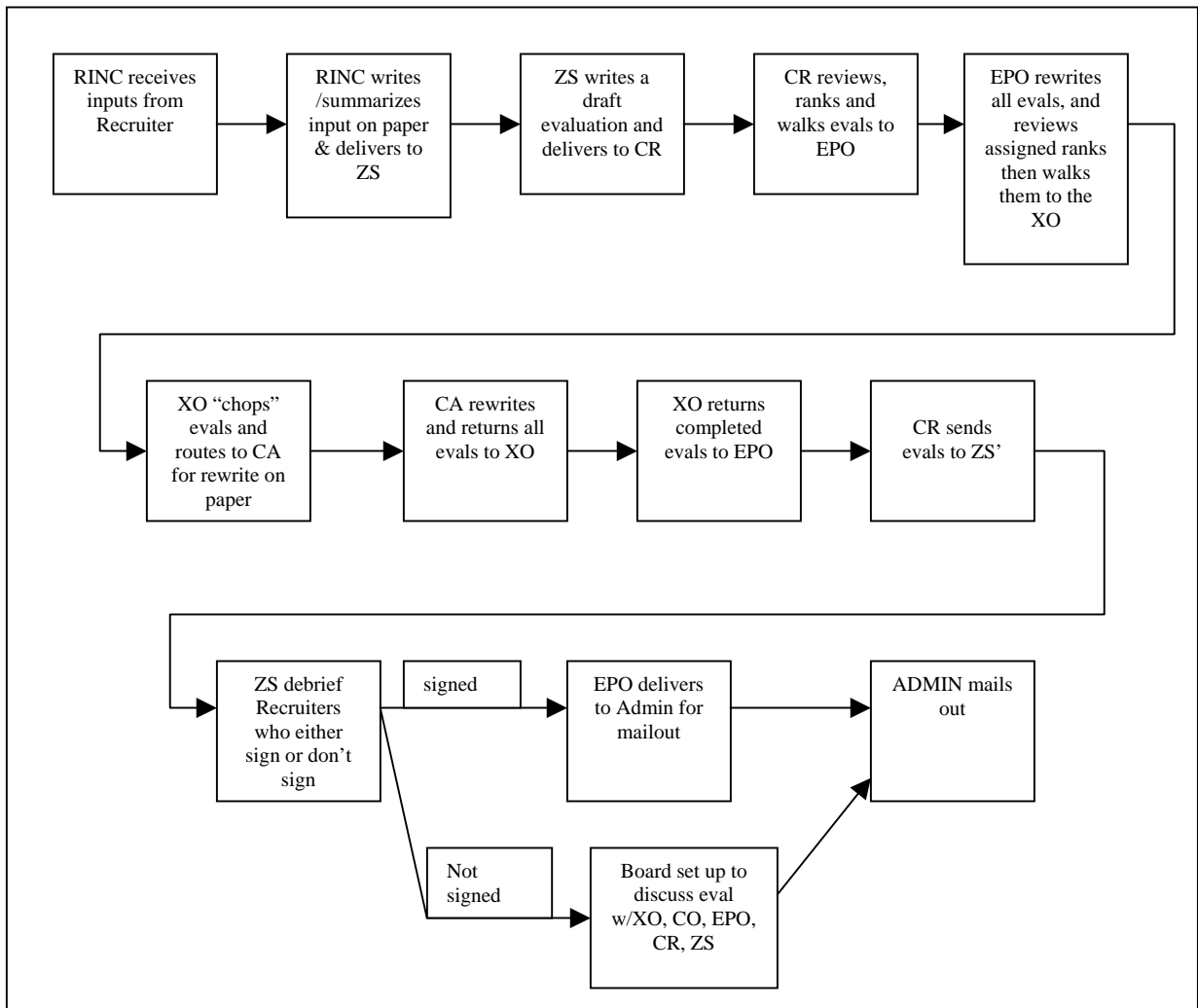

Figure 3.7. Evaluation/Fitness Report Process 97-98.

Once the zone supervisors wrote the evals, the EPO and CR discussed rankings in a closed-door session. Once they developed their rankings, the proposed list and the finished evals were forwarded via e-mail to the XO. The XO made his chops and forwarded both the revised list and chopped evals to the CO. The CO made his final chops and returned them to the EPO. If the EPO or CR disagreed with any marks or rankings, they had the leviety to meet with the CO or XO. After further discussion, the final rankings and evals were decided upon and the evals were printed out, signed by the CO, and distributed via guard mail, overnight express, or duty-driver to the field.

The zone supe was then responsible for reviewing them and distributing them. If he had any disagreements with the marks, he too had the freedom to discuss any issues with the CR and the EPO. A huge effort was made to resolve any disagreements in a timely manner in order to get the evals back before the 15th of the month they were due. The district never missed a due date on evals in the 99-00 timeframe.

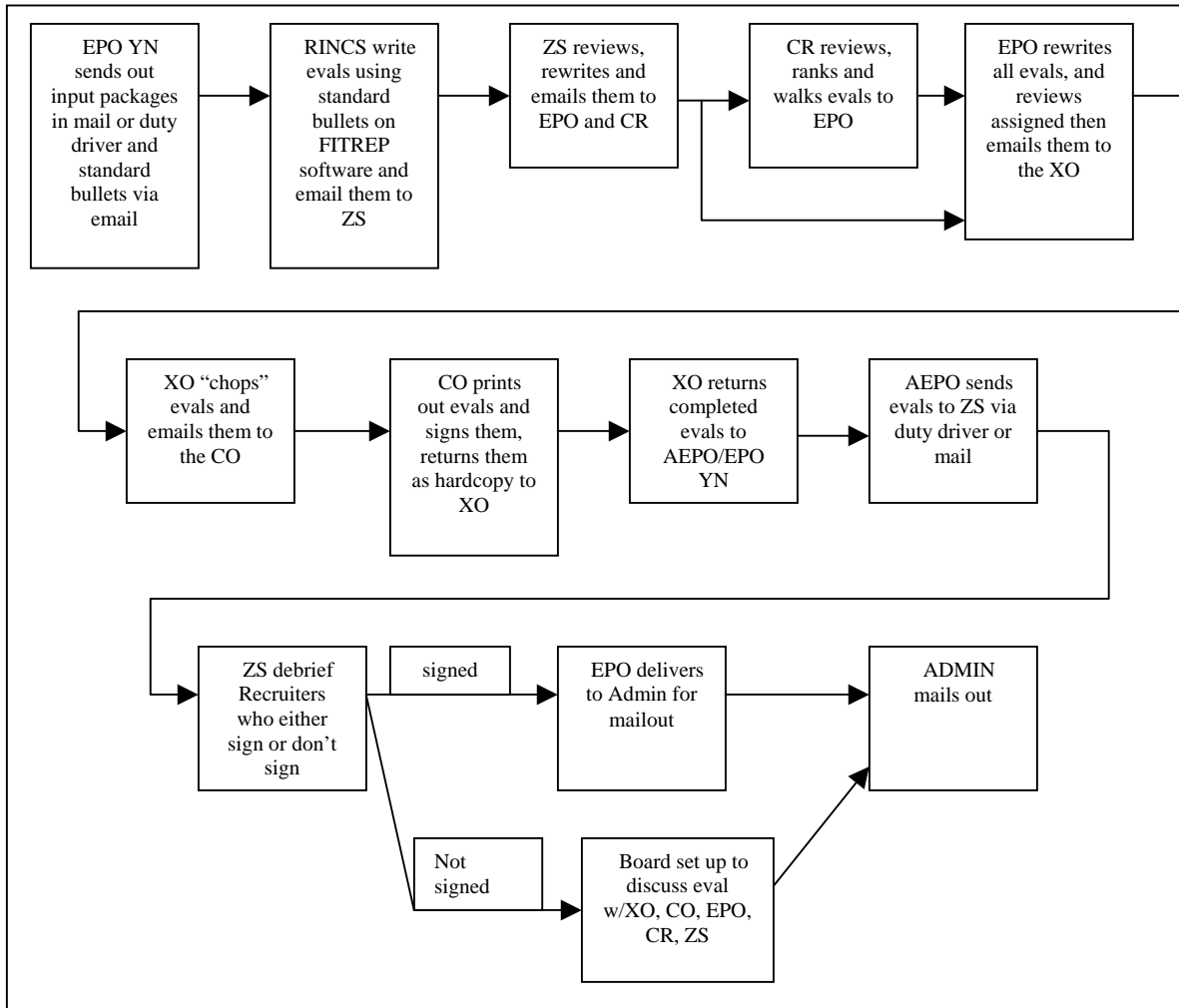

Figure 3.8. Evaluation/Fitness Report Process 99-00.

(2) Measurement and Controls, Financial Management. The following process answers the question: how are people held accountable for resources?

Resource Accountability. The process of resource accountability differed only slightly between the two districts. The primary difference was that the 99-00 recruiters had more resources with which to work. Recruiters had several resources for which they were accountable. These include government vehicles, cellular phones (and their usage), government credit cards, laptop computers and their recruiting stations. Although there were government vehicle logs, cellular phone bills and credit card bills, the recruiters, for the most part, were trusted to be responsible for their resources. Car accidents and repairs were rare, but did happen. Credit card improprieties rarely occurred. Cell phone use in 99-00, however, was abused because of the freedom given to recruiters for their use. That is, the word put out by the cell phone contractor to the command was that the cell phones would cut off after a certain amount of time was used. Unfortunately, that function never worked. Therefore, the recruiters, thinking their cell phones would cut off after a certain amount of time, used their cell phones well beyond the time stipulated in the terms of the contract. As a result, the district was almost \$30,000 over its assigned cell phone budget for several months in a row.

(3) Planning, Communication and Information Management. The following processes describe the planning, communication and information management processes conducted by both districts.

Planning. The primary planning tool used by all recruiting districts is the Production meeting. Usually, all key players in the recruiting process attend the meeting. These players include the CO, XO, EPO, CR, EPDS, Senior Classifier, LTCS, LSO and CA. The 97-98 era saw two different methods of conducting Production meetings. In 1997, when the district was consistently making goal, the command held a production meeting every Monday, Wednesday and Friday morning. In 1998, however, the command held a production meeting every day. The meetings became very tedious and actually hurt production more than helped. "It got to be too much...I had to delegate someone to go to the meetings for me because I had to go out to the field."¹¹²

Generally, the meetings began with the EPO quickly summarizing current NCO goal attainment for the month, and then discussing predictions and forecasts

¹¹² Chief Recruiter, October 2002.

for the coming week. The EPO then discussed shipping goal, and the progress or lack thereof, of obtaining that goal. The EPO was followed by the OPO, who talked about Officer Recruiting. The LEADS Supervisor discussed past and current LEADS conversion rates. That is, he reported how well the recruiters were “turning-over” available LEADS.¹¹³ The department heads in attendance then talked about relevant production activity in their departments. The XO gave a report on current administrative and personnel actions, and the CO ended with words of support, motivation and/or reprimand.

The XO also held Department Head meetings on Tuesdays and Thursdays. Everyone from the production meeting attended these meetings except for the CR, EPDS, and Senior Classifier. They were joined by the AEPO and the command secretary. The XO discussed such events as administration, public affairs events, personnel issues and budget issues.

In 99-00, there were two major meetings held each week, a single production meeting and a single department head meeting. The production meeting, chaired by the CO, took place on Wednesday mornings. All the department heads attended, as well as the AEPO, Senior Classifier and/or EPDS, and sometimes the CR. The CR was not required to attend the production meeting, but often did because of two reasons 1) she wanted to be there and/or 2) the CO requested that she attend. The bulk of the information put out was by the Enlisted Programs Officer, the Senior Classifier, the Officer Programs Officer and the LEADS Supervisor. One of the interesting aspects of the production meetings was the CO’s willingness to allow proxy Department Heads to attend instead of the actual DH, just as long the actual DH had a viable reason for missing the meeting. For example, the EPO attended the vast majority of the production meetings. However, in that rare occasion where the EPO had to be at MEPS or in the field for whatever reason (station-visit, re-enlistment, etc.), the AEPO or CR would take his place without any complaint from the CO.

The department head meeting took place directly after the production meeting. These meetings evolved from one meeting a week to two meetings, taking place on Mondays and Thursdays instead of Wednesdays after the production

¹¹³ Recruiters were given leads by the LEADS department, and were expected to call them to see if they are actually interested.

meeting. This decision, unfortunately, took too much time away from the EPO's ability to run production so the attendance was delegated to the AEPO. Although the XO did not appreciate this on some occasions, the over-riding need to make goal was more than enough justification for missing the meetings.

Communication. In general, the primary method of communication between the members of the district in 97-98 was by fax and telephone. E-mail was not widely used. The CO was very active in calling her recruiters on a daily basis to encourage, motivate and "sometimes to just say hi."¹¹⁴ She also sent handwritten notes of congratulations. The CO was also "on the road" constantly, visiting stations. She knew her recruiters very well and spoke to them about personal as well as professional issues.

Formal communications operated in a traditional, military, top-down hierarchy with restricted lines of communication. The Commanding officer was at the top of all communications lines. The Executive Officer expected all communications to the Commanding officer to go through her first. There were two distinct lines of communication: the administrative communications flow and the production communications flow. While the XO was the focal point of all administrative concerns, the CO still wanted to see every piece of documentation that left the command. No one was allowed to bypass the XO when it came to administration. The EPO, during this time period, was the major contributor to admin issues. The CR did not have an active role in administration. The AEPO also helped the EPO with administrative concerns. Figure 3.9 shows how communications regarding administration was conducted.

¹¹⁴ Assistant EPO, September 2002.

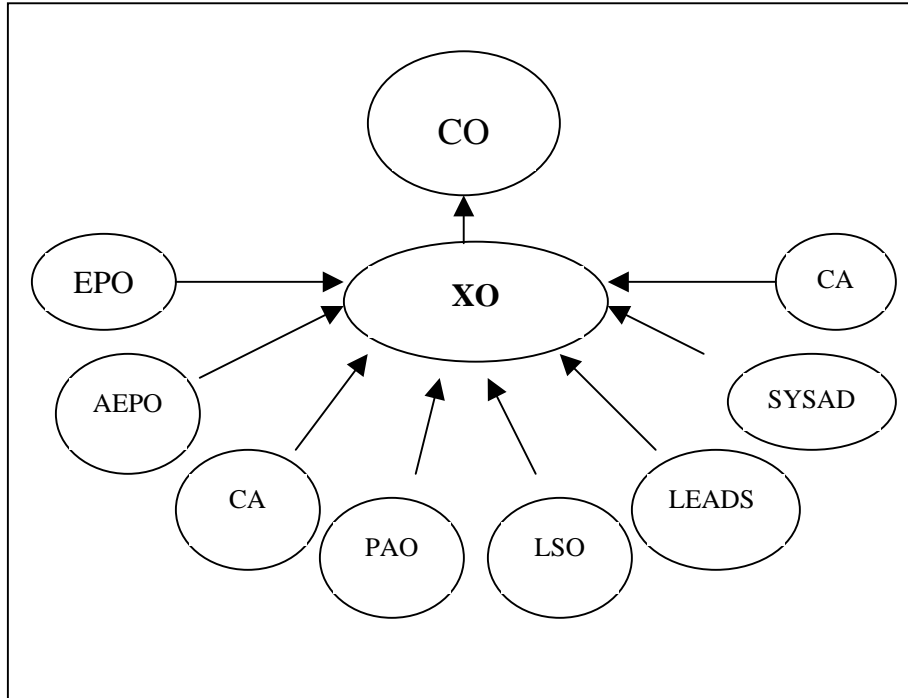

Figure 3.9. Administrative Communication Flow 97-98.

The CO was the focal point and final authority of all production concerns. The CR, EPDS and EPO had direct lines of communication with the CO regarding all matters of production. Zone Supervisors spoke only to the CR. RINCs spoke only to their Zone Supervisors. The Senior Classifier communicated via the EPDS and/or EPO regarding shipping matters.

The XO and most of the other department heads did not figure into the production communication flow. Figure 3.10 depicts the flow of communications with regards to production in 97-98.

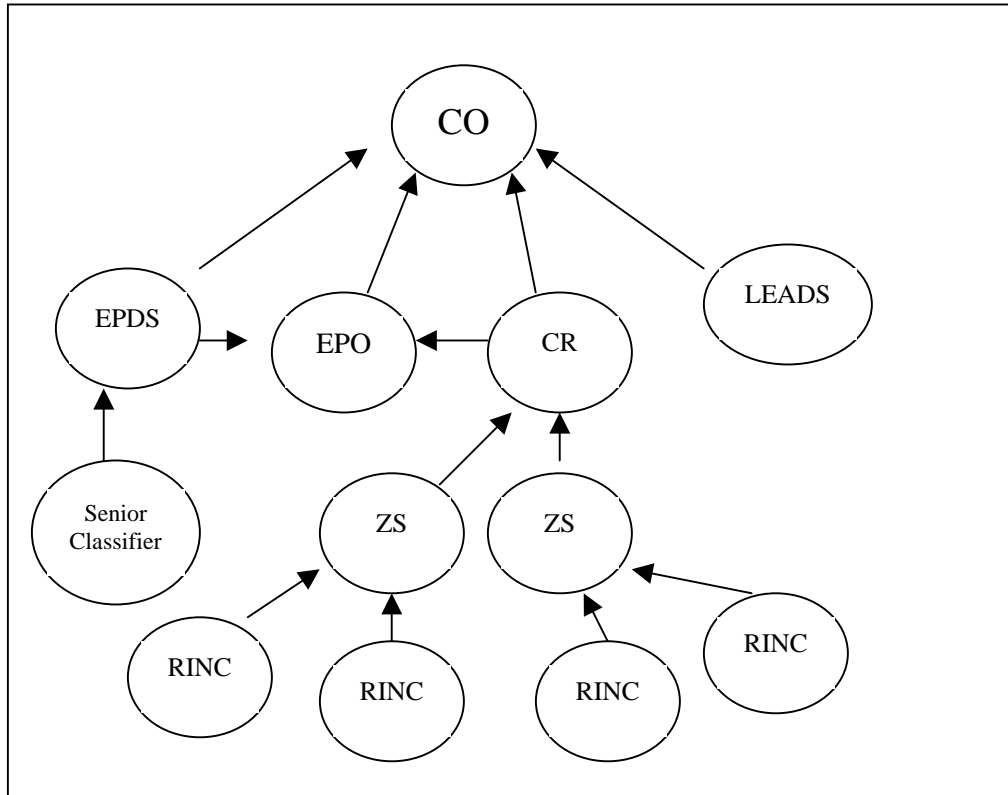

Figure 3.10. Production Communications Flow 97-98.

There were definite communication barriers in the 97-98 district. The XO did not want to hear information second-hand when it came to most significant issues. The XO also required most communications, whether written or oral, to the CO to go through her first.

The 99-00 district communicated primarily through phone and e-mail. The district had the advantage of cell phones and high speed internet service, so communication was more efficient and faster in this time period. The CO, EPO and CR still drove out to the field, however, citing the success “windshield time” had on crew morale. Fax machines were almost never used, except when the e-mail went down. All documents which could not be reproduced in a Microsoft Word or Excel format were scanned (each station was required to have a scanner) and then sent over the email in a .pdf file.

In addition to the administration and production communication flow, the 99-00 also had a distinct accessions communication flow. The administrative

flow differed slightly from the previous time period. The XO was still the focal point, but had more authority to sign out and release documents. That is, the CO did not have to, nor did he want to, see everything that left the command. Anything that could be delegated, such as 1306 requests, were delegated to the XO. The CA did not exist and most of the communication with personnel issues took place between the AEPO and the XO. Like the previous command, the AEPO had a direct line with the XO on all matters of administration. In 99-00, however, the EPO did not have an active role in routine matters of administration. Most of the day-to-day correspondence was handled by the AEPO, even leave and special request chits. The EPO and CR received a courtesy copy on all correspondence, since most of the documentation was electronic. Figure 3.11 depicts the administrative communication flow of the 99-00 district.

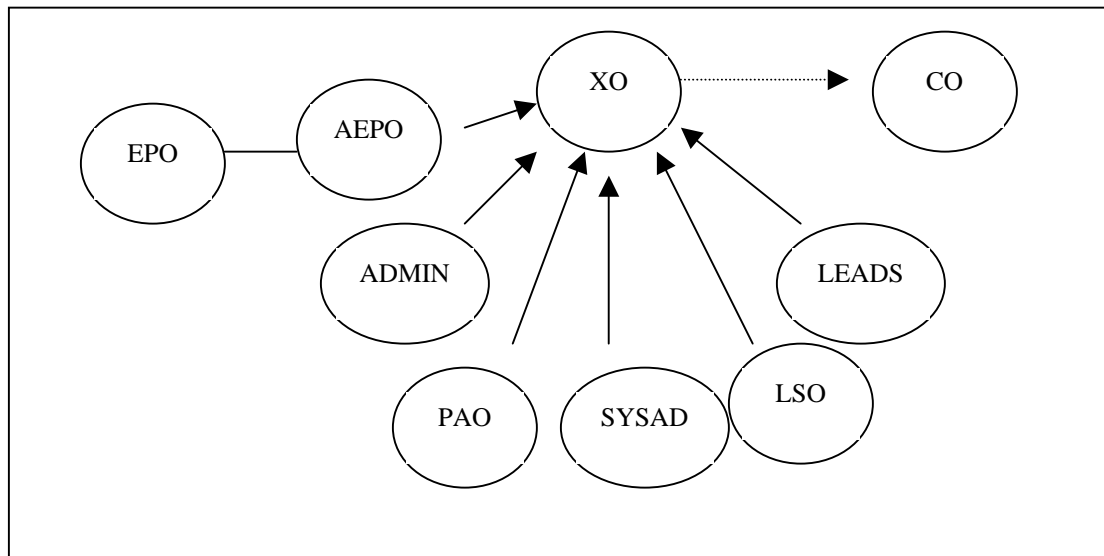

Figure 3.11. Administrative Communication Flow 99-00.

The 99-00 production communication flow also differed from 97-98. The CO was still the authority, but there were more direct lines to him than before. The CO had a direct line to the Chief Recruiter, and sometimes by-passed the EPO altogether to find out information about NCO production. As well, the Chief Recruiter had a direct line to the CO any time she pleased to talk about NCO's. The Zone Supervisor were also free to speak with the CO at anytime. As well, the CR allowed the

zone supes to run their zones almost autonomously. That is, she did not micro-manage their training or production activity. Additionally, with regards to waivers, the EPDS and even the waiver clerk spoke directly to the CO regarding applicants. The EPDS or Waiver PO conducted interviews and passed on the information to the CO, courtesy copying the EPO on e-mail, and the CO conducted his interview from there. The XO had minimal involvement in NCO production.

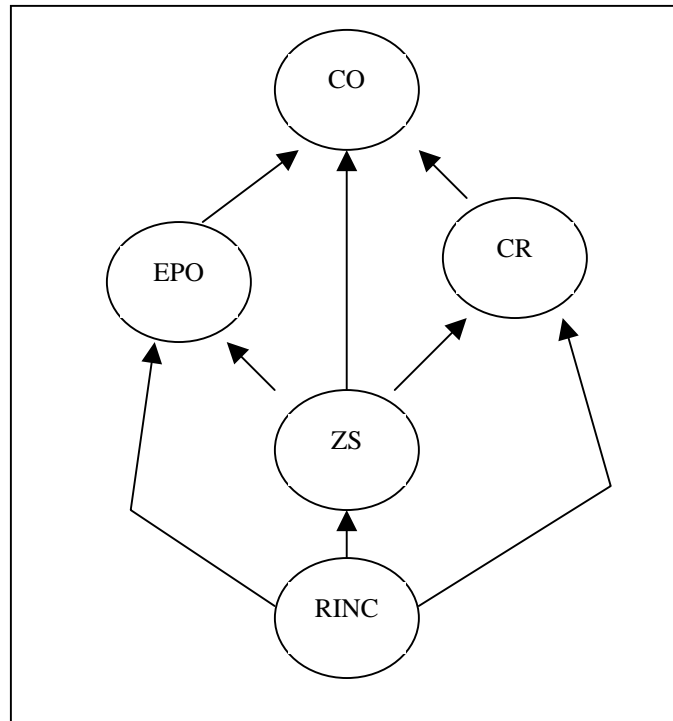

Figure 3.12. Production Communication Flows 99-00.

Another distinct and highly defined communication line was the Accession goal chain. The CO and EPO spoke directly to the EPDS and/or Senior Classifier regarding shipping issues. The CR was not called for routine matters. She *was* called when the district were in danger of missing shipping goal. Since the CR controlled the DEP pool, she could direct the zone supervisors to “roll-up” DEppers to take “closer” shipping dates. As mentioned, this was a point of contention with the CR, who believed that she should have been intimately involved in every aspect of production. However, the CO believed in getting the information efficiently and quickly; and sometimes the CR simply did not have the type of answers the CO needed. For example, the CO may have wanted to know how many non-high school graduates the district had left to write in a

particular month. The Senior Classifier knew the answer. The CR would have had to ask the Senior Classifier in most cases. In fact, the Senior Classifier was the primary source of accession goal information for all the key players, except for recruiting issues such as possible attrites. Those issues were handled by the CR.¹¹⁵ For the most part, however, the pertinent information regarding shipping numbers were provided by the Senior Classifier. Figure 3.13 describes the accession communication flow.

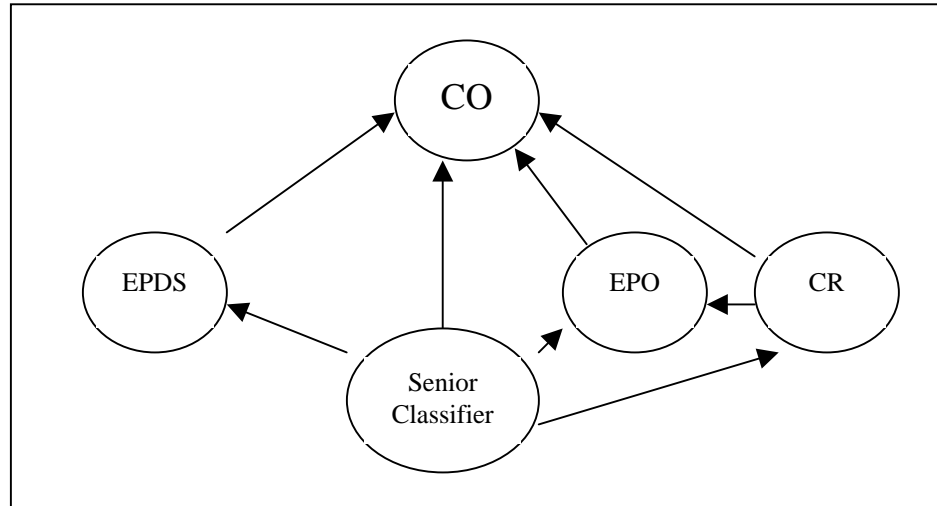

Figure 3.13. Accession Communication Flows 99-00.

In sum, the 99-00 district tore down communication barriers and flattened out hierarchical patterns. The EPO wrote e-mails directly to the CO. He walked into the CO’s office whenever he had an issue and called him at his home or his cell phone whenever he felt the need. As a result, however, the EPO was seemingly “on call” 24 hours a day. In recruiting, problems occur at all hours of the day and night. Recruiters can get in car accidents, shippers do not report to leave for boot camp, flights from Las Vegas or Orange County get delayed. As one zone supervisor put it, “there’s no 9 to 5 and there’s no answering machines when it comes to recruiting.” The recruiters, zone supes, and CR had their cell phones on all day and night. They knew

¹¹⁵ An important aspect of shipping goal are possible attrites that will show up later in the month, that must be accounted for in order to determine how close the district will be to making accession goal. The CR, based on information she receives from her zone supervisors, has the most accurate prediction of unaccounted attrites. The Senior Classifier would not know this information since he is not in any way part of the zone supervisor’s chain of command. The district tried to alleviate the problem of unforeseen attrites by forcing the recruiters to identify and “take” their attrites by the 15th of each month.

they could call the EPO and CR anytime. The EPO also called them no matter what the hour. The district realized this and made communication flow as fluid as possible.

Unfortunately, the freedom of communication resulted in several problems. The use of e-mail to contact the CO directly led some in the district to undermine the EPO and CR's authority. Several times, recruiters e-mailed the CO with complaints about such issues as quality of life, awards recommendations and evaluation marks. For example, one recruiter e-mailed the CO voicing his discontent over working on a Saturday. The CO replied, with a blind courtesy copy to the EPO and CR, explaining that the zone supervisor was well within his bounds to have his recruiters work on Saturday if it prevented missing goal. The EPO and CR then received a separate e-mail from the CO with a reprimand for not training the field to use maturity and professionalism when given the privilege of flat communications. Fortunately, most members of the district understood the limits of the district's barrier free communication policy.

The open chain to the CO regarding production and accession matters was also a point of contention with the CR and EPO. Although they were both courtesy copied and/or back-briefed on most communications between the zone supervisors/EPDS/Senior Classifier and the CO, sometimes they had to hear news second hand from the CO himself. For example, the CO called the EPO and CR in one morning and asked "why five shippers were missing on the day they were supposed to ship out? (this was information he received earlier in the morning from the Senior Classifier)." The EPO and CR had received the report that all shippers were accounted for. The Senior Classifier, as it turns out, did not have an updated list of shippers for that day, and gave the CO inaccurate information.

For the most part, however, "bypassing" the chain was not an issue with most of the leadership given the nature of the work. In fact, all the EPO required for most e-mails was a courtesy copy on his cell phone if the Senior Classifier, EPDS, or the CR needed to speak with the CO about urgent issues. The EPO did not want, in any way, to impede communications with the boss.

Information gathering and distribution (statistics management).

As the CR would often say, "the field wouldn't really care if the district didn't have a

PAO; but they would get really mad if the district didn't have a good statistician." NRD SD recruiters were interested to see how they were doing. Most of the recruiters were very competitive and wanted to compare themselves to others. The RINCs were proud to see their stations doing well. The daily Production Report provided the recruiters vital information.

How did the 97-98 district disseminate the statistics? The production report, which showed new contract attainment, status of shipping goal attainment, station and zone status and individual recruiter status, was distributed to the field via fax machine. At the end of the production day, the Statistician had to manually input the numbers each night, printed the document, and sent them to the field via mass fax. He had to fax either late at night or very early in the morning. Otherwise, the fax machine in the EPO office would be closed to incoming and outgoing traffic for one to three hours.

The 99-00 Statistician was a Microsoft EXCEL genius who revised the entire input and reporting program. As mentioned, instead of manually inputting the stats, he wrote a program which automatically downloaded the information from the MEPS to his office PC. He distributed the new production report via e-mail in the afternoon.

(4) Other Procedures Related to Enlisted Production. The following procedures are all sub-processes vital to making goal.

DEP-IN Procedures. There were methods of DEP-in used at MEPS in 97-00. The 97-98 district depped the recruits in the standard way, even on large volume days. The 99-00 district used the standard method on "light" days, but employed a revised version on heavy days. The standard flow is described as follows with the revised, more efficient deviations of "front-loading" and "night processing shown in parentheses.

- **Transport.** Applicants spend night in hotel near MEPS (in NIGHT PROCESSING, applicant is brought to MEPS for processing before going to the hotel). The applicant brought to MEPS at 0500 by bus, or by government vehicle if applicant is local bullets should be .5
- **Check In.** The MLPO checks the applicants in and gives them name tags. They are then sent to a two-three hour comprehensive **Medical examination.**

- **Processing.** After the medical exam, the applicant is sent to waiting room outside of MEPS liaison to await processing. On heavy days, with more than 20 applicants on deck, the applicant may wait for up to three to four hours. (when FRONT LOADING is used, applicant sent to get fingerprints taken and security questionnaire completed, a step usually completed after processing) Paperwork is processed while applicants in medical. (In FRONT LOADING, the paperwork is processed the night before) Processors review applicants' paperwork and produce an enlistment "kit." The processors then interview the applicant, asking information about any possible criminal activity or medical condition not divulged to the recruiter. If an issue arises, then the processor sends the applicant the Waiver PO for further processing. Afterwards, the applicant must wait, as long as two to three hours) for the next step. (In FRONT LOADING, those applicants who did not get fingerprinted now do so instead of waiting. Applicants can also be NIGHT PROCESSED, meaning they process with a night-shift processor the night before DEPPing, saving valuable time during the day.)
- **Classification.** The MLPO then directs the applicant is sent to one of three to five classifiers to choose a rating and corresponding shipping date. If the District or the nation has a particular need, the classifier tries to "sell" the applicant on a particular job and/or shipping date. For example, the Navy may need to ship more people out this month than next month, so the classifier will try to sell the applicant on shipping out this month. The bottom line, however, is to try and give the applicant what he or she wants
- **Security Interview and Fingerprinting.** The MLPO then sends the applicant to get fingerprints taken and security interview conducted by the MEPS staff. The applicant then returns to the waiting room for his/her swearing in ceremony, which are conducted each hour on the hour.
- **Swear-In.** An officer administers the oath to the applicants in a ceremony room at the MEPS.
- **DEP Brief.** The new DEPper signs his/her enlistment contract. He or she is given a t-shirt, hat and backpack and leaves MEPS a member of not only the NRD DEP pool, but a member of the US Navy.

All along the way, the Military Liaison Petty Officer (MLPO), a PN1, updated his schedule, which listed all the DEPpers and where they are currently in the process. The 97-98 district employed a paper tracker, differentiating the different stages with colored markers. The 99-00 implemented a Microsoft Excel-based DEP tracker on his desktop. The tracker was automatically e-mailed to the field and headquarters every 30 minutes, which precluded the need for the recruiters to call and ask where their applicant is in the process. Figure 3.14 contrasts the standard method of

DEP-In to the Frontloading (combined with night-processing) method used on heavy volume days.

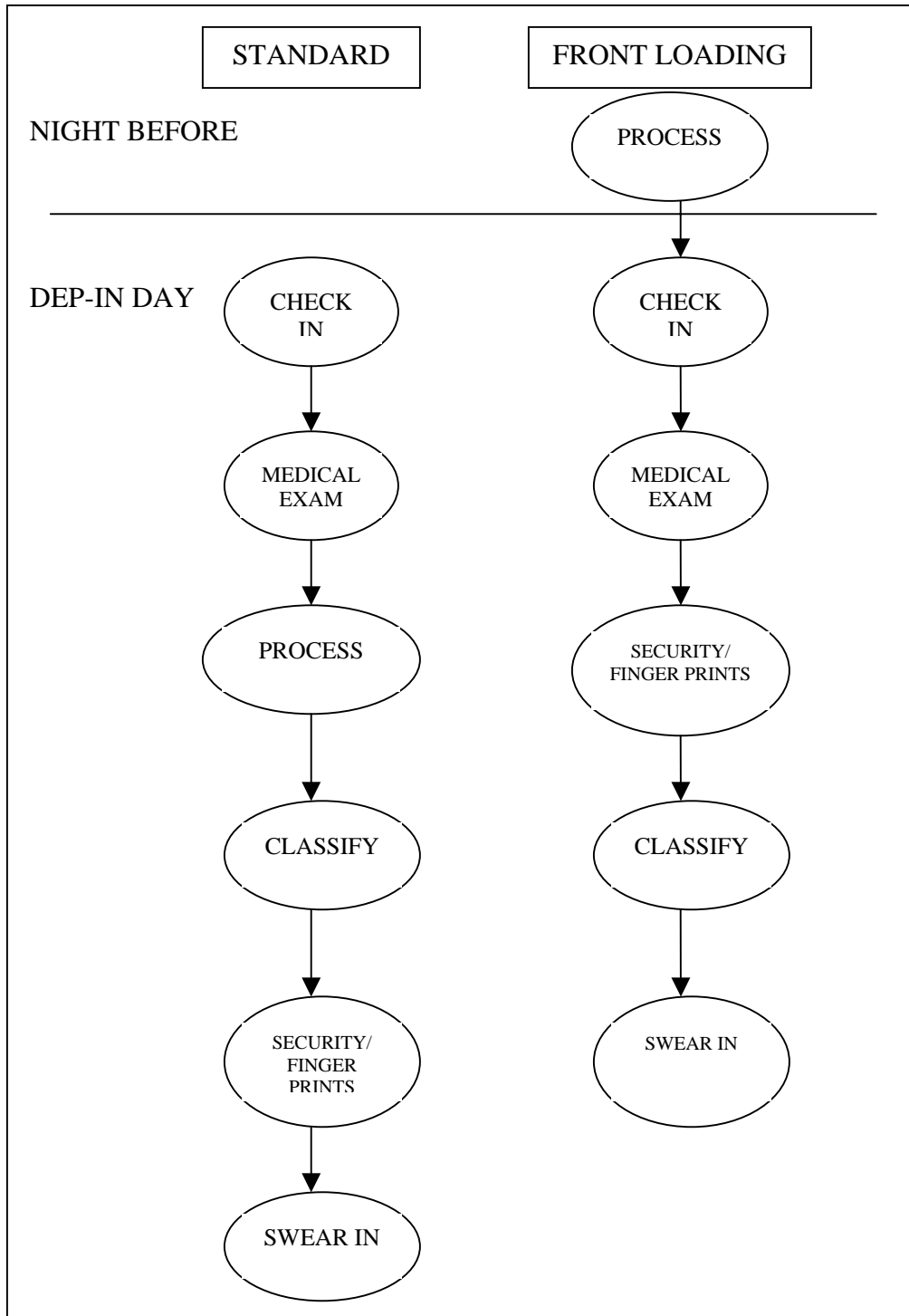

Figure 3.14. Standard DEP-in and Frontloading DEP-in.

Education Verification. All required paperwork (transcripts, will-grad letters, etc) and an Educational Verification form was faxed to one of 97-98's two EDSPECs for review and signature. The EDSPEC then faxed the forms either back to the recruiter or to the EPO's office, and the EPO walked the paperwork to the CO for signature. The EPO then faxed the paperwork to the MEPS and the recruiter. The EDSPECs, unfortunately, were often on the road and difficult to reach. Applicants would therefore not be able to DEP in because they had incomplete BEERS documents. Faxing the documents also presented a problem when the documents were lost, or the fax machines were broken. (See Figure 3.15).

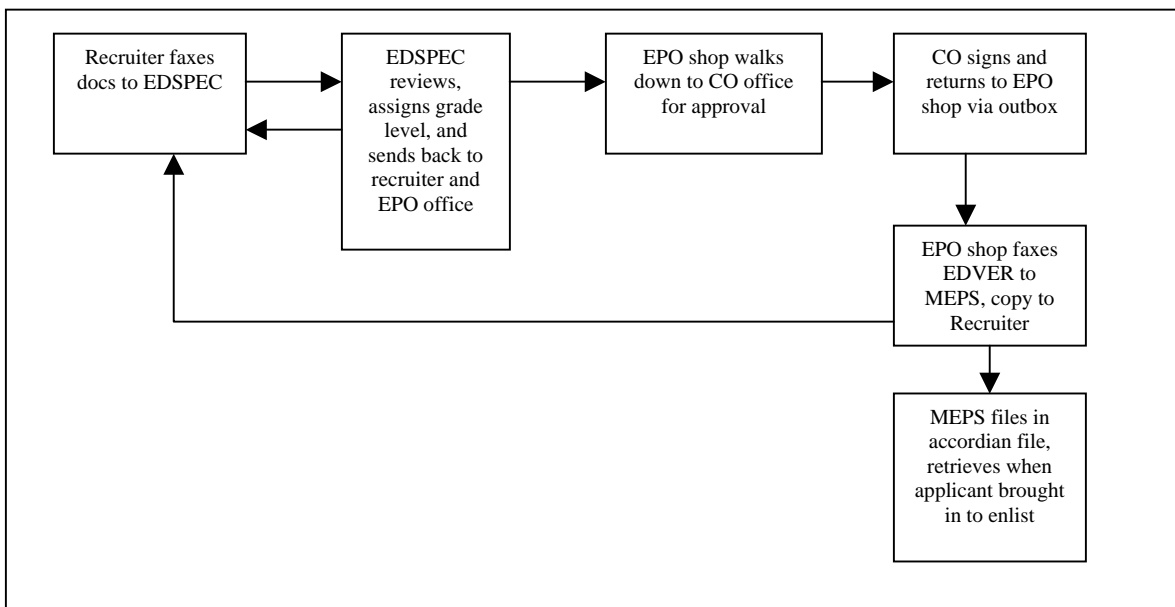

Figure 3.15. Education Verification Process 97-98.

NRD SD 99-00 faced even more difficulty when the funding for EDSPECs was reduced and San Diego had to operate with only one EDSPEC. Once again, the district utilized electronic methods in an attempt to improve the efficiency of the process. The documents were e-mailed (after fax-scanning) or faxed directly to the EDSPEC's assistant (a civilian contracted office automation expert). She then scanned them into her computer (if faxed) and filled out an electronic EDVER form (if the recruiters haven't already done so). She e-mailed the form and the attachments to the EDSPEC, wherever she was, for review and signature. If she was at a school, the

EDSPEC Assistant e-mailed the forms to the nearest recruiting station. After review and signature (electronically), the EDSPEC sent them back to the Assistant who then e-mailed them to MEPS and the CO. This told MEPS that they needed to expect an EDVER. The CO then reviewed and signed and sent back to MEPS, the Assistant and the Recruiter. (See Figure 3.16).

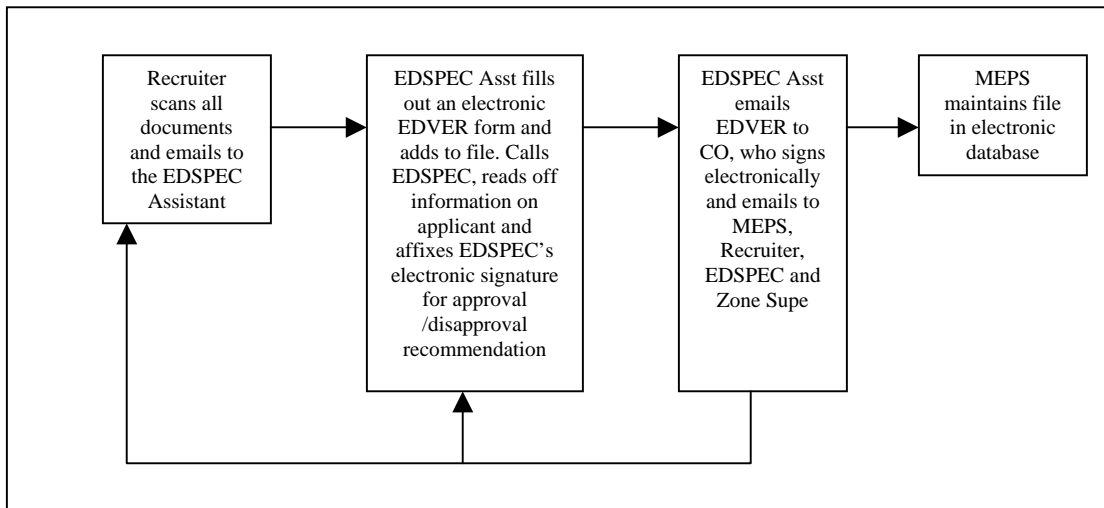

Figure 3.16. Education Verification Process 99-00.

DEP Activity Reports (DARs). As discussed, DARs are used to track any changes in a DEPpers status. DARs were routed via fax in 97-98. The recruiter would fill out a DAR in the station, route it to the RINC who signed it. The RINC then faxed the DAR to the zone supervisor, who recommended approval or disapproval and faxed it directly to the CR or to the EPO's office, where one of the EPO Admin personnel would walk the DAR to the CR's office, and more specifically, to her inbox. When she eventually got to the DAR, she would sign and walk it over to the EPO's inbox. The EPO would then call the CR, ZS or RINC to find out more information about the DAR, especially if the DAR was an in-month attrite or roll-out. The EPO then walked each DAR to the CO and the two discussed the situation surrounding each DAR. The CO would then sign the DAR. The EPO faxed the DAR to MEPS and walked the original back to the CR, who faxed a copy back to the zone supe. (See Figure 3.17).

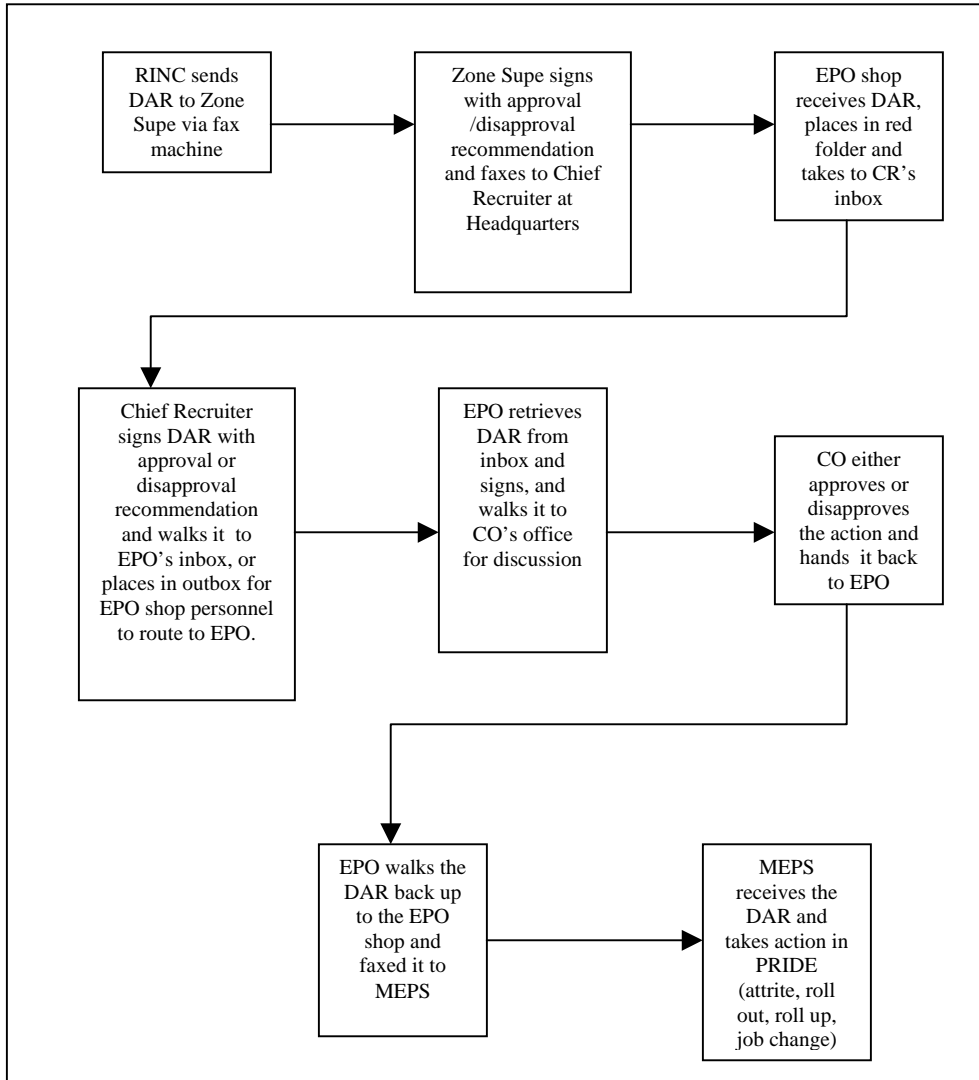

Figure 3.17. DAR Routing Process 97-98.

The 99-00 era routed DARS electronically. The RINC's emailed them on electronic format to the zone supervisor. The supes, in turn, e-mailed the electronic DARs to MEPS, the EPO Yeoman, the CR and the EPO. MEPS was notified to give them a "heads up". The EPO Yeoman took the DARs and filed them so that they would not be lost. The CR and EPO were then supposed to act upon the DAR and forward them to the CO for signature.

After the CO received the DAR, he would sign and approve or disapprove, then send it back to the EPO, CR, Zone Supe, MEPS, and RINC, so that everyone had it. If the CO wanted to discuss the DAR with the EPO or CR, he requested

a meeting. If not, he signed them electronically and sent them out. The process was much faster than the 97-98 process. It also prevented lost paperwork. (See Figure 3.18).

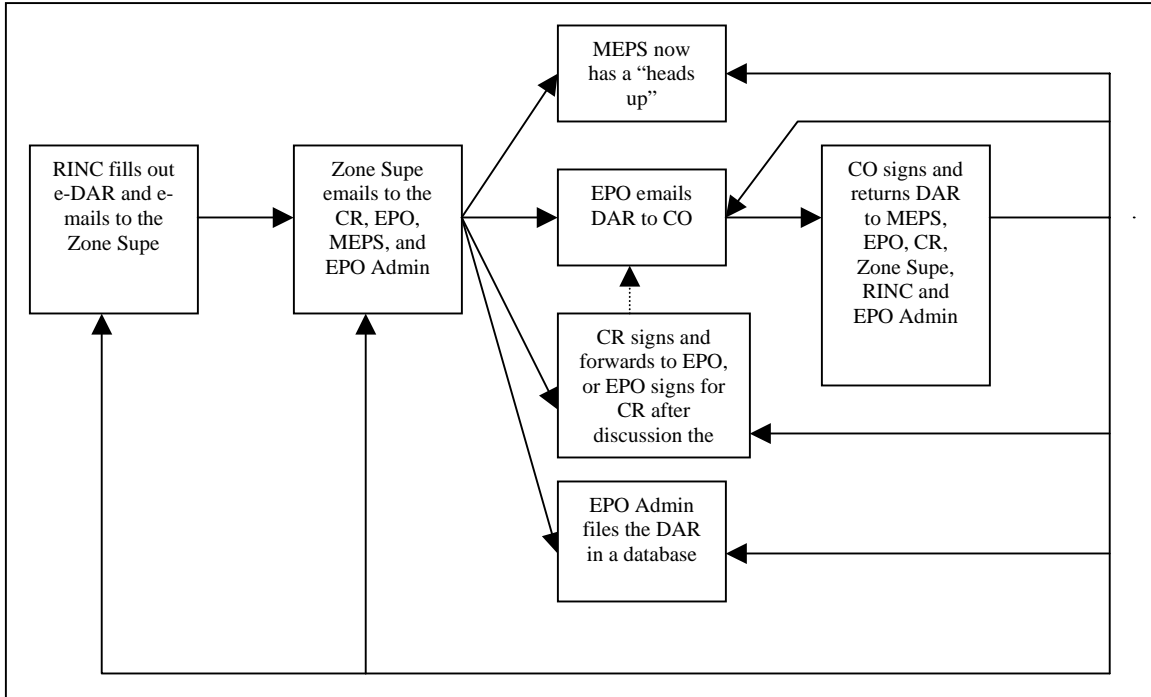

Figure 3.18. DAR Routing Process 99-00.

Attrition-handling. The 97-98 district was very active in identifying and “taking” attrition as soon as possible. All attrites, even those with just an outside chance of actually going to bootcamp, were identified and taken early in the month. The EPO had a good idea of who the problem DEPpers were because she often conducted personal audits. The 97-98 developed a reputation for a “clean” DEP pool. This, combined with the immediate ship (i.e. smaller DEP pool), precluded any fears of DEP audits.

With the increased volume of contracts in 99-00 came increased DEP attrition. These “lost opportunities” for accessions caught the eye of the Region, who was also trying to make goal. Identified as a critical success factor, reducing DEP attrition became one of the tougher challenges of the 99-00 district. All in- and out-month attrites were identified and taken before the 15th of each month. Taking the attrites early in the month was done for two reasons: 1) the district had a “clear picture” of how

many contracts they actually had to write during the month and 2) the attrites held job and bootcamp reservations which had to be cleared so that other recruits could use them. If they were attrited late in the month, those bootcamp and job reservations would be lost forever. Although most attrites were identified and taken before the 15th, a good number would appear towards the end of the month. The reason was simple “there were possible attrites that the zone supervisors and RINCs did not give up on, and took a chance that they would go.”¹¹⁶ “The recruiters wanted to make goal so badly that they took chances even though they knew the ramifications would not be pretty. Sometimes they went, sometimes they didn’t...the risk was worth it.”¹¹⁷

LEADS. The 97-98 LEADS department was typical of most districts. It was manned by recruiters who were soon departing or could not “hack it” in the field. The LEADS cards were sent out to the recruiters by the department and the LEADS telephone operators answered calls from persons who called the national telephone number or answered advertisements in the local paper. The LEADS department provided an adequate, but a spectacular amount of local and national leads to the command. Figure 3.19 depicts the 97-98 LEADS Marketing process.

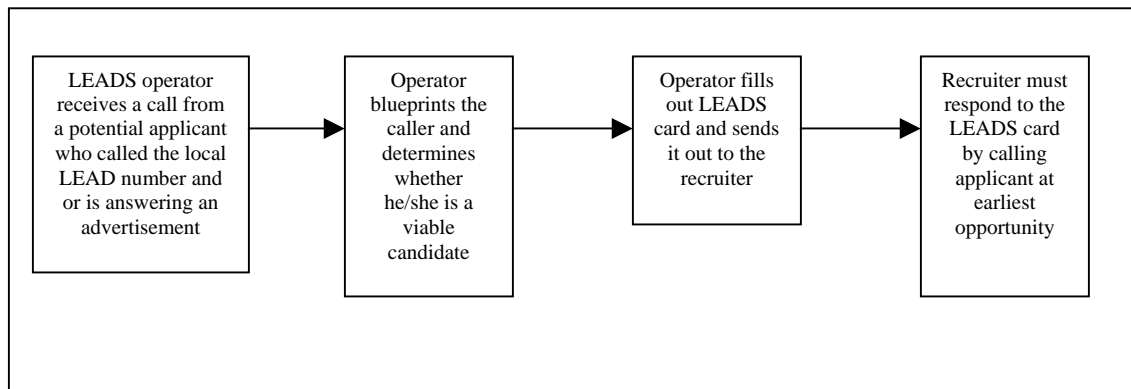

Figure 3.19. LEADS Marketing Process 97-98.

The 99-00 command pioneered the LEADS tele-marketing process. Whereas most LEADS are distributed to the field, and the recruiter or RINC is then responsible for calling them, San Diego established a pro-active LEADS process in

¹¹⁶ Chief Recruiter, October 2002.

¹¹⁷ Zone Supervisor, July 2002.

which the LEADS personnel call the LEADS prior to the recruiter. Calling them beforehand accomplishes two objectives: 1) it provides an extra level of screening so the recruiters don't have to waste their time with false leads and 2) it allows the recruiters more time out in the field instead of "chained to their desk." Once contact is made with the LEAD, the tele-marketer (who is a former recruiter) blueprints and tries to conduct an initial "sale" on the applicant. The tele-marketer will then perform a three-way call on his phone with the applicant's area-assigned recruiter. Once three-way contact is established, the recruiter sets up an appointment to see the applicant. If the recruiter is not available, the tele-marketer will set up the appointment anyway, and inform the recruiter at a later date. (See Figure 3.20).

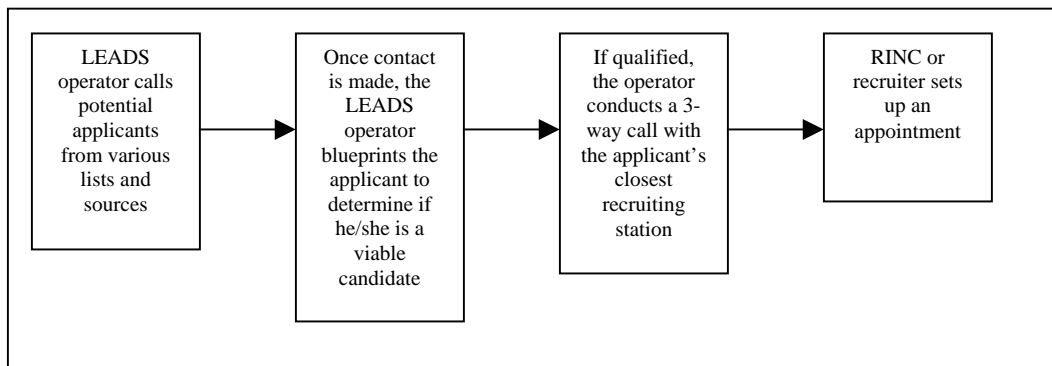

Figure 3.20. LEADS Tele-Marketing Process 99-00.

3. Culture

What are the prevalent norms and values in the system as they are expressed in behavior? What role did leadership play in the system? What are the rituals, ceremonies, symbols that occur within the organization?

a. Norms and Assumptions

One of the most significant norms of the 97-98 district was the *overriding need to make shipping goal*. In this era, the nation as a whole was operating in an immediate shipping posture. CNRC needed to fill bootcamp seats in a hurry, and did not have a large DEP inventory from which to choose. Subsequently, San Diego included, concentrated on recruiting "workforce" contracts who could leave for bootcamp in a hurry. As well, DEPpers who were shipping out later in the year were constantly "rolled up" to ship early. Unfortunate consequences of this action include sending a DEPper

who is not yet ready (mentally, physically, financially, socially) to go to bootcamp and DEppers losing jobs they were promised because the accelerated shipping date forced them to change their rating selection.¹¹⁸

Another norm in 97-98 was that *business must always be conducted ethically*. To eliminate improprieties, the command constantly preached “doing the right thing” when recruiting. For example, if a recruit did not have the exact type of court documents needed to clear a possible criminal offense, then that applicant would not be considered for enlistment. Applicants with juvenile records would often have sealed records which would explain incidents in their record. If this was the case, and the documents were sealed, the recruiter would more than likely not even bother trying to enlist the applicant, no matter how forcefully or passionately the individually professes his or her innocence.

The command dealt with other issues such as sexism, fraternization and improper relationships with pronounced punishment. Anyone suspected of such activity was immediately called “to the carpet,”¹¹⁹ questioned and subsequently monitored closely.

Because the district was not effectively able to make NCO goal on a consistent basis, the expectation for NCO was “almost is good enough.”¹²⁰ The reasons for not making goal piled up: the larger goals, high turnover rate, large number of non-volunteer recruiters, good economy, and low unemployment. Recruiting was difficult and instead of pushing to make NCO, the district was content to make shipping goal, since “shipping goal is the goal that counts.”¹²¹

Because of all the changes that took place in the district’s system, the culture also changed dramatically in 99-00. The first norm was that *missing goal was not*

¹¹⁸ Recruits are given jobs based on the availability of those jobs after bootcamp. Sometimes, the jobs are lost because the recruit rolls up to ship early, but the job he originally wanted is not available during the early time frame.

¹¹⁹ Refers to the act of being called in to headquarters to personally see the XO or CO.

¹²⁰ Zone Supervisor, July 2002.

¹²¹ Enlisted Processing Division Supervisor, November 2002.

an option. NCO and accession goal, were “must-makes.” Missing NCO constituted failure.

The entire field saw the value of making goal. Making goal not only improved quality of life, it also increased the recruiters’ utility. It got to a point where making goal was not the question. The question became: “How much are the district overwriting goal by this month?” The following are various quotes from NRD personnel provided as evidence of their glowing pride:

We felt good about ourselves. We saw ourselves as winners” when the district made goal.

The district wanted to be winners, not losers. Goal was the way to prove ourselves winners. In fact, the district didn’t really understand why other districts were not making goal. In all honesty, we view them as losers.

The mindset of the district was that we were good at what we did. And what we did was put people in the Navy.

No one from the outside was allowed to criticize Team San Diego. We don’t think anyone deserves or has earned that right.¹²²

We expect to make goal. There’s no ifs, ands or buts about it. Each station, zone and district is expected to make goal. If they don’t, then they feel ashamed. If they don’t, they feel like they’ve let the rest of the team down.

With the new commanding officer, enlisted programs officer and re-vitalized and experienced Chief Recruiter came a new attitude regarding NCO goal. “Whereas NCO was considered an option in the previous year, it became a “must-make” in Fiscal Year 1999.”¹²³ The Chief Recruiter, who felt a bit “stifled” and was admittedly inexperienced in the previous era, was not only allowed more levity to perform her duty, but also had a year of experience under her belt.¹²⁴ The district, as a whole, made a concerted effort to make NCO. “The district had a new attitude. The district now *had* to make NCO. If we didn’t make goal, then we failed. As professionals, we surely did not

¹²² This was a standard reaction when an outside entity such as the Region West Process Action Team (PAT) Team or CNRC Navy Training Team came to “inspect” the district’s processes.

¹²³ Ibid.

¹²⁴ Chief Recruiter, November 2002.

want to fail...that would mean losing...and we were definitely not losers!”¹²⁵ Consider the following stories:

On the morning of mission day, November 1999, a high-ranking officer walked to the CO’s office and proclaimed: “we have 48 people on deck...isn’t that great! That’s more than the we’ve ever had.” The CO looked at her with a sharp gleam in his eye and simply said...” That’s not enough...get some more.” As it turned out, the district needed 51 recruits to make NCO. With only 48 “on deck”¹²⁶, the district would surely fall short of goal. The CO was looking for at least 70 persons on deck to have a chance of making the NCO goal. The CO had an emergency meeting with the CR and EPO. He demanded that the recruiters find more people to put on deck. The CR called out to her zone supervisors and throughout the day, more prospects showed up on deck. Reasons why these persons were not previously on deck were because: 1) the recruiters, having already made their personal or station goal, were “saving” them for next month 2) the recruiters did not really care about the district goal, and 3) the recruiters were not willing to take a chance on a prospect with possible criminal or other problems; i.e. the recruiters were not willing to put any extra effort in to putting in a recruit that may need a little “extra work.”¹²⁷ The district not only made NCO goal that month; there was a new feeling of accomplishment that pervaded the entire district. “We felt like the district won a hard fought game or battle. It was truly refreshing.”¹²⁸

The next month, December, was also a very tough month for recruiting. With most of the recruiters thinking about the upcoming holidays, the motivation to recruit was floundering. “November was great, but December is traditionally a hard month” said the recruiters. To which the CO replied “Who said it’s hard?...nothing’s hard if you set your mind to it.”¹²⁹ On mission night, which lasts until 2100 Pacific Standard Time, the district needed one more contract to make goal. At 1800, everyone but the CO and CR had all but given up. Then the CR called her zone supervisors in for a closed-door meeting. They went through their prospect lists and found a possible recruit in Victorville, CA, which is about 2 hours away from the MEPS, the place where recruits are processed and contracted. The call was made to Victorville. The reason

¹²⁵ Recruiter, May 2001.

¹²⁶ “on deck” means that the recruits are civilian prospects who have passed the ASVAB (although some may be taking the test on that day; in that case, they are Same Day Processors) but still have to go through physical (medical) and criminal screening. Because of these filters, 48 prospects do not guarantee 48 contracts. In fact, the average “conversion ratio” for San Diego was about 70%. Therefore, with 48 on deck, San Diego expected, at the most, between 35 to 40 of them to become contracts, which would leave them short of their goal.

¹²⁷ Zone Supervisor, October 2001.

¹²⁸ Chief Recruiter, August 2001.

¹²⁹ Ibid.

why the prospect was not on deck was because he could not get out of work. The recruiter talked to his boss, got him off work, and drove him down to the MEPS. The prospect, who was already physically qualified, signed up and swore in. San Diego made NCO with 3 minutes to spare. Considering the complex coordination with CNRC's PRIDE¹³⁰ shop, this was truly a remarkable feat. Once again, the district made goal and everyone went on to enjoy the holidays knowing that San Diego was a winner.¹³¹

During the final quarter of fiscal year 1999, Region West was assigned a substantial NCO goal increase by CNRC. CNRC wanted to bolster its overall DEP pool and also try to make national shipping goal. San Diego's goal increased by nearly 80 contracts over the months of July, August and September. The CR and EPO decided that the best strategy was to place most of the increased goal in the month of September. She believed that 1) the recruiters would push harder at the end of the year, and 2) it gave the district a chance to at least make the July and August goals. September's goal ended up being 299. The EPO and CR (although she would not admit it) entered the month with a little bit of apprehension at the daunting 299 staring them in the face. The CO, in a closed-door session with the CR and EPO, openly expressed his concern about such a high goal. At the end of the meeting though, everyone agreed that the CO, XO, EPO, CR and Zone Supervisors must go into the month with a positive and unrelenting attitude about making the goal. "We are making 299" were the CO's final words. With energy and proactive leadership (the CR, CO and EPO called stations and recruiters at random to "pump them up"), the recruiters came out with a flourish. By the time mission day rolled around, the district needed 65 more contracts to make the 299. They had already written 234 contracts. On the morning of mission day, FY1999, NRD San Diego had well over 100 persons on deck, with 20 to 30 more to arrive during the day. San Diego wrote 308 that day, the most every written by the district, and the most ever written by any district in a month. San Diego finished the year well above their fiscal year goal (105 percent) and was named District of the Year by CNRC.

In general, the recruiters, RINCs, zone supervisors, CR, EPO and CO were unrelenting in making goal. The CO made personal calls to the BUMED doctor on several occasions in order to determine the status of a waiver. Additionally, he wrote

¹³⁰ PRIDE is the Navy's classification and job reservation information system. It stands for Personalized Recruiting for Immediate and Delayed Enlistment. The PRIDE Operators are located in CNRC headquarters in Millington, TN and are responsible for classifying personnel into specific jobs and bootcamp seats. A contract does not count as a contract until placed in the PRIDE system.

¹³¹ Chief Recruiter, December 2001.

personal notes to the doctors at Navy Medical Center (MEDCEN), San Diego explaining the importance of the applicants with consults to the recruiting effort.¹³²

Unfortunately, the zeal with which the EPO and CO performed their duties was often a source of friction between the district and the MEPS. MEPS personnel are responsible for scheduling consults at the Navy Medical Center. Oftentimes, the consults were scheduled at a distant date. The problem was that the applicant was now not going to “count” as a contract for the current month. In these cases, the EPO would call the MEDCEN himself and if he could, schedule appointments within the month. Sometimes, the MEPS received word of the EPO’s actions and responded with very harsh criticism. On one occasion after hearing that the EPO scheduled an asthma consult¹³³ without the MEPS knowing, the Lead MEPS Physician, a Captain in the Navy Medical Corps, forbid the EPO from entering the MEPS command.¹³⁴

Additionally, the MEPS was often of accused of not being concerned with goal attainment. As a Joint shore duty command, the members included military personnel from all services as well as civilians. They performed a complicated job filled with schedules and deadlines that often impeded the mission of the recruiters. For example, the doctors who performed the physicals did not see any applicants after a certain cut-off time in the afternoon, so late arrivals were not allowed to process. The shipping clerk had to have all shippers in the MEPS before 0500 on shipping days. The last applicant could not “cross the line” to get processed after a certain cut-off time, forcing that applicant to come back the next day. This presented a problem if the applicant had school or work the next day. The recruiters, operating in conditions which sometimes called for 16 to 20 hour days, could not accept the fact that a vital link in their recruiting process had so many hindering effects. Said one veteran recruiter,

It was definitely a source of frustration...I don’t know how many times I had an applicant waiting five or six hours and then told that he or she

¹³² Applicants with possible medical conditions were often sent to Navy Medical Center, San Diego for consults by specialists. For example, an applicant with bad acne would be sent to the NAVMEDCEN dermatologist to determine if he or she had a disqualifying condition. Even if the consult came back as disqualifying the applicant could be considered for a waiver by BUMED.

¹³³ PFT or Pulmonary Function Test.

¹³⁴ Personal experience, June 2000.

could not finish processing because of cut-off. It's not the kids' fault that the MEPS can't handle the volume.

The incessant need to make goal was obvious at all levels of the recruiting chain. The recruiters were driven by their RINCs, Zone Supes and the CR to make their station goal. As one RINC put it, "if our station didn't make goal, we weren't doing our job. That's the bottom line."¹³⁵ Zone supervisors felt the same way about their zones. In fact, according to one of the zone supervisors, "my RINCs are ashamed to miss goal...especially if everybody else makes goal. Missing really makes us feel badly. We hate missing; hate it more than anything."¹³⁶ The CO, CR and EPO felt the same way about district's goal. The CR even went a little further. Her tack was to have "all stations and all zones" make goal. Although some stations did not make it, all her zones made NCO goal.

To emphasize her point, she sometime held what were termed "come to god" meetings¹³⁷, as they were affectionately known, for those recruiters, RINCS and zone supervisors who were not performing up to their potential. For example, in one particular month at the 50 percent gate, she called a short notice meeting with all those recruiters and their RINCS who had not written one contract. The purpose of the meetings was not to reprimand, "but to train."¹³⁸ Some of the recruiters had to drive three to five hours to make the 0900 meeting. Although she attempted this sort of training in the previous era, the tactic was not completely supported by the senior leadership.¹³⁹

Another norm established by the new district was the *development of teamwork and sense of family*. There was a definite sense of family among the recruiters. Quarterly awards ceremonies were as much social as they were official. The recruiters truly respected one another and "got along" very well. There were no real conflicts, except for minor disagreements between CRF personnel and the fleet sailors. Those

¹³⁵ Recruiter In Charge, May 2001.

¹³⁶ Zone Supervisor/District Trainer, December 2001.

¹³⁷ Assistant EPO, November 2001.

¹³⁸ Zone Supervisor, May 2001.

¹³⁹ Chief Recruiter, November 2002.

conflicts, however, were expertly mediated by the zone supervisors and if needed, the CR. There was no need for the EPO, XO or CO to be deeply involved in any conflict management.

The second commanding officer of the 99-00 time period made teamwork central to the district's way of thinking. He even revised the district logo to read "TEAM SAN DIEGO." He related the district to a sports team and announced our quest for another championship.

The Chief Recruiter pointed out time and time again the importance of sticking together. She meant that in two contexts. First, the CR, EPO and CO must always be on the same page. She said, "the recruiters can easily sense when there is a rift between the CO, CR and EPO, and would be forced to choose sides. A district can't produce that way." She continued, "if ever the CO and I had a disagreement, we discussed it in private, and delivered a united message. Much the same way, the CR and EPO must always appear to agree. Any differences between the EPO and CR could be devastating to the morale of the field, she contended. The EPO could put out a message without the CR's blessing that might run counter to something the CR just put out. Difficult issues such as DEP attrition and management must be handled together and the policies put out must be completely supported by both parties.

The second area in which teamwork was extremely important occurs between the CR and zone supervisors. She often referred to her six zone supervisors as her "knights of the round table." She respected each of them for their ability and knowledge. The feeling was mutual.

The CR was almost like our mama. She could really bother us sometimes, but in the end, all the scoldings were for our own good. She knew how to motivate, how to inspire and how to get us focused. I can speak for all the zone supes and say that we wanted to be on her team, and that we felt we were the best team in the nation.¹⁴⁰

¹⁴⁰ Zone Supervisor, July 2002.

The CR reciprocated:

Those six guys were the best set of zone supervisors in the nation. They were the best I've ever seen. Most of the time, there's bickering, jealousy and sometimes even hatred between zone supes because of the competitiveness of the business. This group was not that way. They genuinely loved each other, and helped each other out.

The CR and EPO were also an outstanding team. Although there were no major conflicts with the CR and the EPO in the previous time-period, there was also no real effort to develop an in-depth relationship. The 99-00 CR and EPO disagreed about many things, but did so in private. "They argued a lot, but when they came out of the office, it was all smiles. They started out on different chapters, but ended up on the same page."¹⁴¹ The two spoke every day on the phone or in person for at least one to two hours regarding personnel, production and accession issues. The CR said, "I must have received ten calls a day from the EPO. But I'm not complaining, that's the way it should be."¹⁴² The two became so familiar with each other's leadership styles, preferences and tendencies, that even such tedious tasks as writing evaluations and ranking recruiters became easy. The CR stated, "if he and I were asked to rank the recruiters 1 to 10, we would probably be off by maybe one or two recruiters. We felt the same way about a lot of things."¹⁴³

One area where teamwork improved from the previous time-period was the between the MEPS and the Field. However, there were still problems. The CR and Senior Classifier were often at odds with shipping issues; and the CR and Zones were often at odds with the EPDS about production issues. The direct lines between the EPDS and Senior Classifier to the CO "bothered" the CR, as she felt she was being undermined to some extent.¹⁴⁴ The recruiters even joined in the MEPS "bashing." One anonymous recruiter stated:

Sometimes we felt our MEPS office was out to get us. They sometimes acted like we were intentionally putting in bad contracts just for the bone

¹⁴¹ DEP Coordinator, November 2002.

¹⁴² Chief Recruiter, October 2002.

¹⁴³ Ibid.

¹⁴⁴ Chief Recruiter, June 2002.

(contract). I've even overheard them saying that we were dirty. That's not being a team player.

The author often spoke to the classifiers and processors in MEPS regarding their perception about recruiters. Some of the MEPS personnel would often question some of the recruiters' integrity.

The district also believed that the command wanted the field and headquarters to enjoy recruiting and *enjoy a good quality of life*. Although the recruiters were extremely professional, there was still a sense that the district operated less as a strict military command but more as a production-driven organization. That is, the realization that production was the primary goal led to the belief that the command was not necessarily bound by the traditional restrictions of a naval unit. Musters were taken at the station level. PRT's were held at the zone level so that the "outlying" recruiters did not have to make the long trip to the district headquarters. Recruiters wore civilian clothes or Navy warm up suits a great deal of the time.¹⁴⁵ Petty Officers (2nd and 1st Class) were in charge of Chief Petty Officers.¹⁴⁶ For the most part, the recruiters did not abuse any of these "privileges." They maintained their professionalism and were trusted by the command leadership.

The EPO had an open door, open phone, open cellular and open e-mail policy with the recruiters, as did the CR, as did the zone supes. There was no reason a recruiter could not speak to me for whatever reason. The interaction among all personnel was professional, but at the same time relaxed.

Another norm was that *recruiting was placed above everything else*. The intensity placed on recruiting did not bode well with every recruiter, especially those that could not sell the Navy. Some recruiters found the pressure too difficult to handle. Some even requested to be transferred back to sea duty. Those that could not recruit were, unfortunately, noticed by the command. As long as they tried, however, they would never suffer any negative repercussions. Those that stopped trying, however, were

¹⁴⁵ Friday uniform was officially khaki pants and navy blue or white polo shirts with the district's logo on them. The recruiters were also allowed to wear their official P.T. gear, a Navy blue and gold workout outfit provided by CNRC.

¹⁴⁶ A PO1 could be the RINC of a station manned by Chief Petty Officers; the CPO had to report to the PO1.

“black-balled” by the command and tracked closely.¹⁴⁷ If they became a bad apple, they were removed from the field and processed for a “No-Fault Transfer.”¹⁴⁸ Also, because of the “goal first” mentality, there were many divorces and separations in the district during the 99-00 era. As one recruiter said, “no one was surprised if they heard about one of the guys getting a divorce or being separated”

b. Leadership

The leadership of the organization establishes the vision and sets the example for the culture in such a way that leads the organization towards mission accomplishment. There were four distinct leaders in the 97-98 district. The Commanding officer, Executive Officer, Enlisted Programs Officer, Chief Recruiter each played a role in developing the culture of the organization.

The 97-98 Commanding officer was well-respected in the Region and CNRC for her professionalism and leadership ability. “The CO had a stellar reputation in recruiting. She had experience and knew what it took to inspire the recruiters.”¹⁴⁹ She was well-liked by most of the recruiters. She often called individual stations, as one recruiter put it, “just to see how they were doing.” One of the headquarters personnel believed that “the recruiters appreciated her. She spent a lot of time in the field. She cared about the recruiters’ well-being and quality of life.”

The CO was deeply concerned each month the district missed NCO. “No one felt worse than the CO whenever we missed. I felt terribly, but she was just devastated.”¹⁵⁰ There was almost nothing she could do to try to improve the system. The goal and personnel increase came too fast too soon. The demand for shippers was also exhausting. Improvements in the system took a back seat to the demands of accessions. “The district was caught in a bad situation; we were trying to get better at making NCO but couldn’t because accessions were always occupying our time.”¹⁵¹ The CO realized this and had to make a choice. “Her worst nightmare was that if the district

¹⁴⁷ Anonymous member.

¹⁴⁸ A No fault transfer is a request made by the recruiter for transfer out of recruiting. The recruiter, through no fault of his own, simply could not effectively recruit for the Navy.

¹⁴⁹ Assistant. EPO, November 2002.

¹⁵⁰ Chief Recruiter, July 2002.

¹⁵¹ Ibid.

were ever turned around, the new leadership would be looked at as a savior. What people won't realize was that the recruiters would all be seasoned, as will the CR and zone supervisors. That goes a long way in making goal."¹⁵² Because of the greater demands, the district became reactive as opposed to proactive. Thus, standards such as 90 percent NCO evolved. Although they were not making goal, the standard was not necessarily a negative reflection of the district since the nation was also settling for 90 percent NCO. "As long as the nation wasn't bugging us about NCO, then we continued to settle for 90 percent."¹⁵³

The Commanding Officer also set the standard for ethical conduct. She constantly preached that the recruiters "do the right thing." She emphasized ethics in her mission statement and in her speeches at awards ceremonies. The recruiters reciprocated, avoiding risky contracts and as one zone supe said, "trying to keep their noses out of trouble at all times."

The Executive Officer did not play an active role in production. She did, however, have an impact in the attitudes of the district's personnel, especially about headquarters. It was no secret that the CO and the XO did not agree on several issues. "They often argued, out in the open. The headquarters personnel saw and heard it firsthand. The recruiters also saw them argue."¹⁵⁴ It seemed that the XO and CO's discussions disrupted the harmony of headquarters. "It got so bad that no one wanted to come to district."¹⁵⁵

One contributing factor to that assertion was a well-publicized sexual harassment incident involving the XO and a recruiter. "The recruiter made a sexist and derogatory remark about the XO, who found out and wrote him up."¹⁵⁶ Although the allegations were true, the "recruiters, in my opinion, felt like they were under a microscope" said one zone supervisor. He continued "We felt like we had to watch

¹⁵² Senior Leader, July 2002.

¹⁵³ Zone Supervisor, July 2002.

¹⁵⁴ Headquarters Personnel, July 2002.

¹⁵⁵ Recruiter, July 2002.

¹⁵⁶ Assistant EPO, August 2002.

everything we said or did.” The goal of ethical conduct now took a negative spin. “Do the right thing” became “don’t do the wrong thing.”

Many at headquarters also felt that “the XO needed to monitor all aspects of our jobs, especially administration.”¹⁵⁷ “She had a reputation for micro-management. I knew that if I didn’t tell her something, and the CO knew about it, that I would catch hell for it.”¹⁵⁸

The Enlisted Programs Officer was technically efficient and knew the recruiting business very well. Before taking the helm as the EPO, she spent a year as the Assistant EPO under the tutelage of the EPDS (she worked at MEPS) and the incumbent EPO. She was an outstanding writer but, as one of the EPO shop members put it, “spent too much time writing evals.” As mentioned in her turnover with the incoming ‘99 EPO, she “spent 80 percent of her time on paperwork.” The demands on her time was one possible reason that she was not, as one recruiter put it, “a recognized leader...she just seemed to be at district all the time and never visited us.” She did not, she admits, travel to the field “as much as I should have. I was too busy writing evals and going to meetings at the district. By the time I got home, it was 2000.”

4. Outputs and Outcomes

The 97-98 performed as well, or better than most recruiting districts during that time frame. The district achieved national recognition as the Bronze Medalist (for third place overall standing) in 1998. The success factors as defined by the district were all met. The command made accession goal, the recruiters enjoyed good quality of life and improprieties were minimized. Although NCO goal was not achieved, it was not considered a key success factor for the district in that era.

In the end, this system provides recruits to fill billets at sea. More specifically, the recruiters fill bootcamp with qualified personnel in the form of shippers. As far as Region West was concerned, the primary measure of output and indicator of district performance was not how close the district get to monthly shipping goal, but how much over shipping goal the district can provide. San Diego’s goal was increased almost every

¹⁵⁷ Headquarters Personnel, August 2002.

¹⁵⁸ Ibid.

month in order to “cover” for those districts that were going to come up short on their goals.

The implications of not making goal were felt both within and external to the command. If the district did not make shipping goal (which never happened), the recruiters would probably have felt very disappointed. “The district didn’t want to miss any goals, especially shipping and NCO. With shipping, that’s where the rubber meets the road.”¹⁵⁹ When the possibility arose that the district might miss shipping goal, then the district went into high gear to find DEPpers that would ship early.

External to the command, Region West would not have made many of their monthly goals if not for NRD SD. In fact, CNRC counted on NRD San Diego to make NCO and shipping goal on at least two occasions. One particular month, the district received a personal call from the nation’s EPO asking for one more contract so that the nation could make NCO goal for the first time in two years. The district obliged of course and found one more NCO.

The focus on NCO goal must be re-iterated. The most effective way to make shipping goal was to make NCO goal. As mentioned, the phrase “making goal” specifically meant making NCO goal. The recruiters concentrated on making NCO goal and shipping goal took care of itself. The recruiters actively, but indirectly, insured The district made shipping goal by: 1) actively finding those DEPpers who wanted to leave early and 2) ensuring those DEPpers that were supposed to leave in the current month did leave.

C. ANALYSIS OF FIT

The systems model for the 97-98 district is depicted in Figure 3.21. 1999-2000’s system model is shown in Figure 3.22. Using Harrison’s Questions of Fit framework, and values of fit assigned by the author, the study now analyzes the congruence of the system elements. To recap, “YES” and “YES and NO” answers offer positive evidence of a “better” congruence between system elements.

¹⁵⁹ Enlisted Processing Division Supervisor, December 2001.

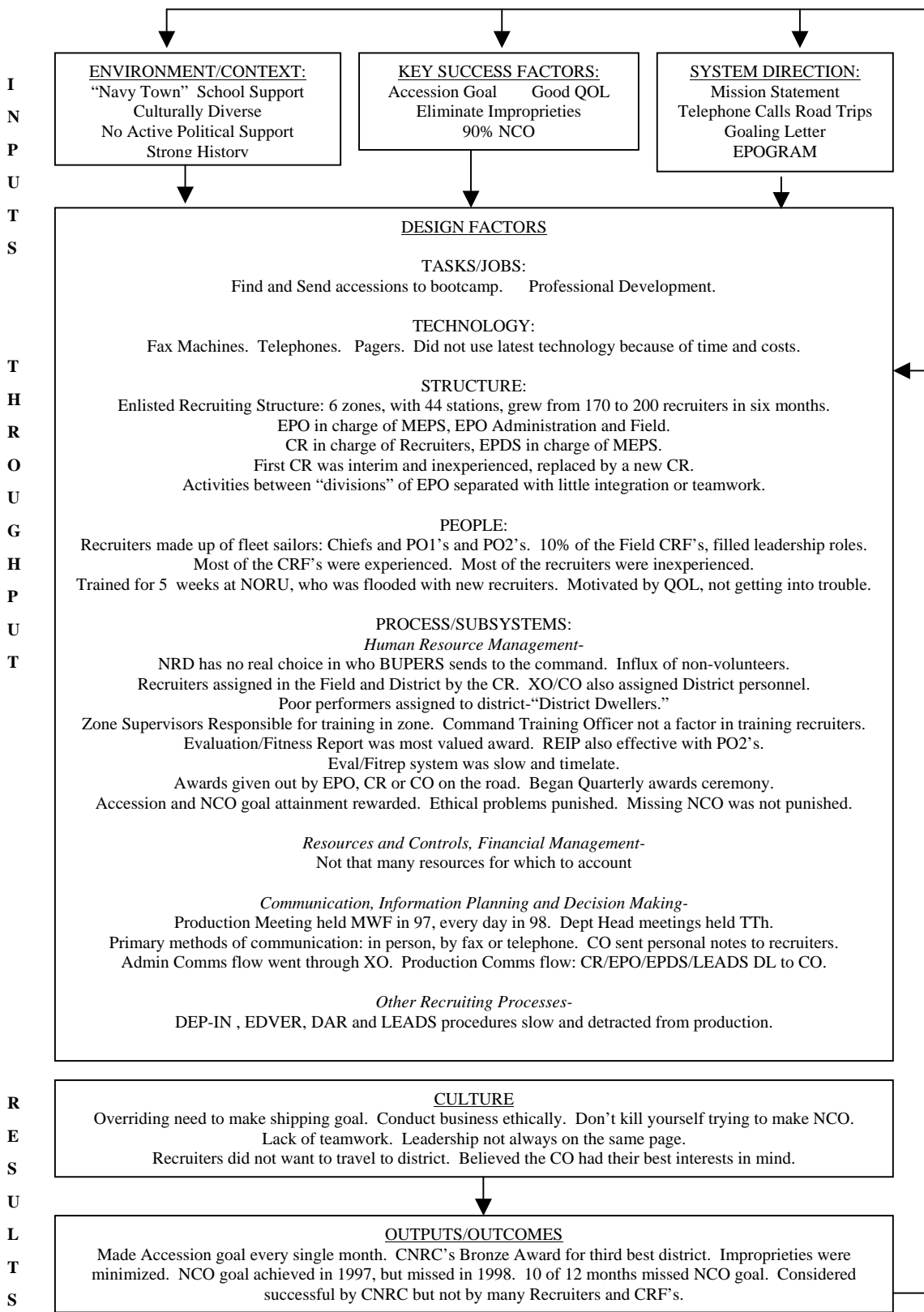

Figure 3.21. Systems Model NRD San Diego FY1997-1998.

I
N
P
U
T
S

 T
H
R
O
U
G
H
P
U
T

 R
E
S
U
L
T
S

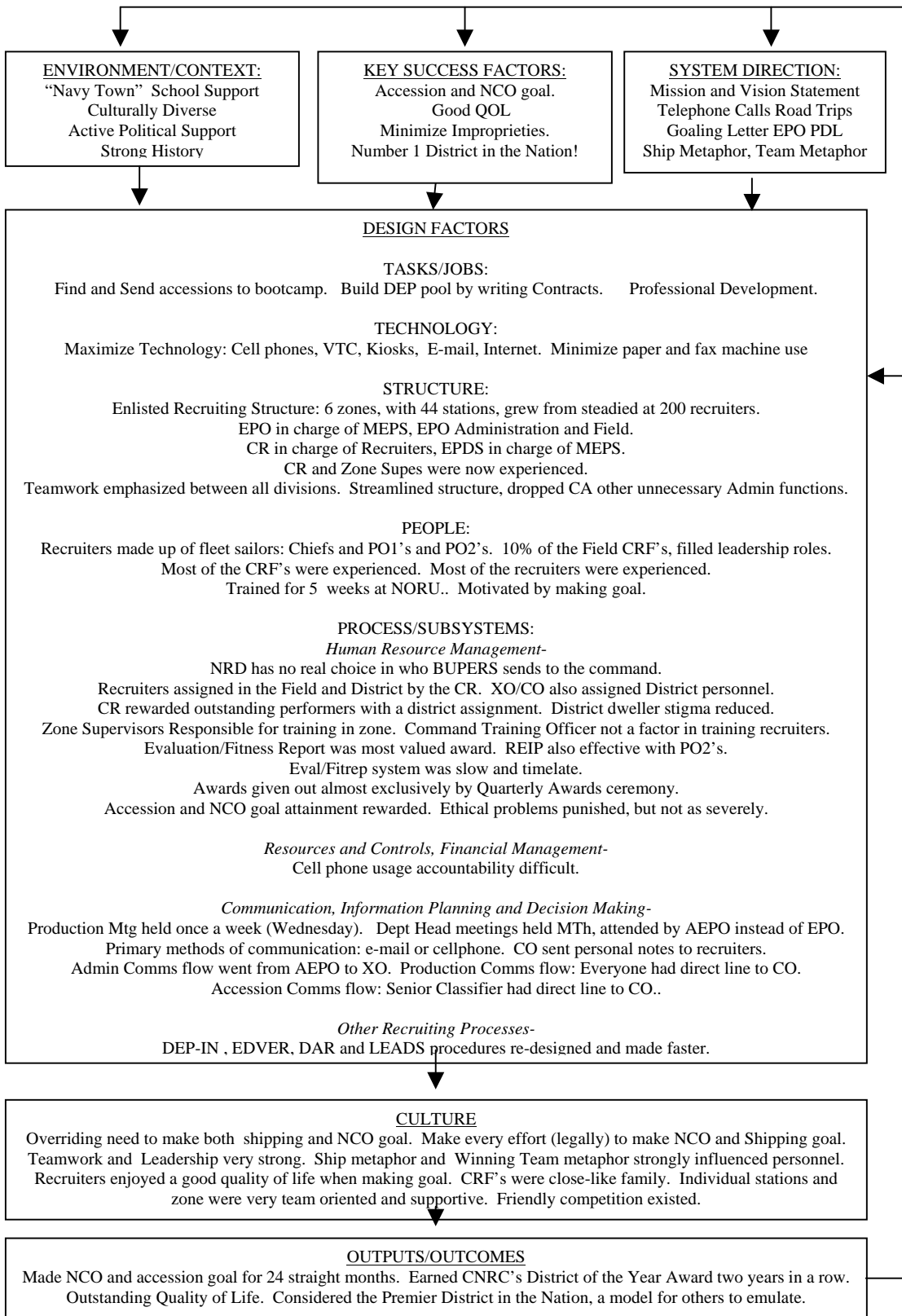

Figure 3.22. Systems Model NRD San Diego FY1999-2000.

The following is the analysis of fit using an adapted version of Harrison's Checklist of Fit Method.

HUMAN RESOURCES

Structure, Technology, Processes

Did the employees' skills and training fit their job requirements?

97-98: NO. The recruiters were trained by NORU for five and a half weeks prior to recruiting. However, most of these new recruiters were non-volunteers who did not want to recruit in the first place.

Some of the guys didn't pay attention at NORU because they knew that NORU was going to pass them anyway. They needed them out there.¹⁶⁰

When they arrived at district, the zone supervisors found it difficult to train so many recruiters at one time, and so many that had bad attitudes.¹⁶¹

99-00: YES. The recruiters received the same training as the 97-98 crew, but were more apt to try and succeed and learn. The zone supervisors were also more experienced in this time period and trained the recruiters more effectively when they reached the district. The non-volunteers who were still at the district also received additional training. More importantly, these non-vols now became accountable for goal and had to actually start recruiting!

Were the best people attracted and retained by the rewards and advancement opportunities offered?

97-98: NO. The best people were attracted to recruiting only because they were part of the large group of recruiters that had to recruit. In other words, there was no real selection criteria for most of the recruiters that reported during the 97-98 time period. The rewards for recruiting are significant. Navy Achievement and Navy Commendation Medals can be earned, as well as a chance for command advancement (REIP). The best sailor, based on previous experience, is not always the best recruiter. Because the criteria

¹⁶⁰ Recruiter, July 2002

¹⁶¹ Zone Supervisor, June 2002.

for recruiting success revolves around production, the best sales person and not necessarily the most squared away sailor, often came away with the rewards.]

YES and NO. The best people were attracted to recruiting only because they were part of the large group of recruiters that had to recruit. In other words, there was no real selection criteria for most of the recruiters that reported during the 97-98 time period. The rewards for recruiting are significant. Navy Achievement and Navy Commendation Medals can be earned, as well as a chance for command advancement (REIP). The best sailor, based on previous experience, is not always the best recruiter. Because the criteria for recruiting success revolves around production, the best sales person and not necessarily the most squared away sailor, often came away with the rewards.

SYSTEM DIRECTION

Resources

Were the organization's strategies and programs supported by available resources?

97-98: YES. The district was primarily interested in making accession goal. The resources to make that goal were available in the district at that time. The district required a large workforce population to recruit and send to bootcamp.

99-00: YES. The command had the luxury of increased resources brought on by CNRC. Not only did each recruiter receive a cell-phone, but the government vehicle ratio was very close to 1 to 1. CNRC gave the district a fighting chance to achieve not only accession goal, but NCO as well.

Environment

Did the organization's strategies, tactics and objectives help it gain and maintain favorable position in its environment?

97-98: YES. With the backlash of media negativity dominating the environment, CNRC demanded accessions. NRD San Diego provided them each month. The strategy of the district was to concentrate on making those accession goals and get as close to NCO goal as possible. The external environment (CNRC) during that time period did not require NCO goal. However, there was an internal environment of recruiters and CRF personnel who did not find the district's position favorable. The constant "kiss and ship"

mode in which the district operated wore down at the morale and motivation of the recruiters. The recruiters spent most of their time looking for individuals who could ship now, and couldn't cultivate those potential applicants in high school who would serve to make accession goal later.

99-00: YES. NRD San Diego gained respect in the communities of Metro San Diego, North San Diego County, Riverside County, Anaheim and Las Vegas as a group that was concerned about the future of the young people in that area. As well, San Diego was considered the premier district in the nation in all aspects of recruiting. Admiral McGann stated on many occasions how she "wished she could clone" Team San Diego.

Behavior, Processes, Culture

Does management express its purposes in ways that create a sense of mission and identity among members?

97-98: YES and NO. The field and headquarters knew the mission very well, make accessions. Write contracts, but don't kill yourself on NCO. "The mission seemed hollow" said one CRF. He continued, "sure, we made shipping goal. But we constantly had stations and zones that missed NCO. To me, that's not mission accomplishment."

99-00: YES and NO. The field and headquarters knew the mission very well, make goal. Missing goal was not an option. As a result, goal was placed above everything. Unfortunately, the headquarters and sometimes even the MEPS personnel felt like they were not on equal standing with the recruiters.

Were efforts to change the organization compatible with current norms, behavior and assumptions?

97-98: YES, but...the only reason they were compatible was because there was no real effort to accomplish *radical change* within the district. The district was reactive as opposed to proactive.

99-00: YES, the district's culture revolved around change.

Culture, Processes

Did managerial plans and objectives contribute to work, or were they too inflexible to handle unforeseen developments?

97-98: NO. This is the area where the 97-98 command was weakest. When NCO and accession goal was low, the district “could make goal with its eyes closed,” said one zone supervisor. “Life was good, we could rely on the big zones to make goal for the entire district. The rest of us just kept our heads above water,” added another. However, when the goals increased, the district maintained the way it conducted business, lowering its “bar” to just accession goal. As the 99-00 CO put it, “we were trying to make goal the same way we used to...it just wasn’t possible...there was no way to excel by conducting business as usual.”

99-00: YES. This is where the 99-00 district truly shined. The entire focus of the leadership was to change processes in order to more effectively achieve goal. Everyone in leadership was required to be extremely flexible

PROCESSES

Structure, Culture

Were those people who must work together closely grouped in units or otherwise linked structurally?

97-98: NO. NRD San Diego is dispersed with many of the recruiters significantly geographically separated from both the MEPS and the district headquarters. Despite the geographic isolation, the recruiters must work intimately with the MEPS personnel and the district’s Enlisted Programs personnel. Some of the key players in production, such as the EDSPEC are also physically separated from the recruiters and the MEPS, as they were required to be on official travel a great deal of the time. The systems in place to help reduce the physical distance, fax machines, landline phones and pagers, worked in 1997 when the goals were low. However, these systems became quickly outdated when the goal increased significantly in 1998.

99-00: YES, the Enlisted Programs Department was housed in it’s own area on the second floor of the headquarters. The Commanding officer was located only a few steps away, but downstairs. This allowed enough physical distance but at the same time

made the CO accessible. The MEPS was located 15 minutes from the headquarters, while the recruiters were connected via broadband internet, email and cellphones. Great strides were made ease the communication between all the members of the enlisted recruiting team.

Are the procedures for coordinating work and information flows appropriate to the tasks and the technology?

97-98: NO. The district conducted far too many meetings and the leadership took a more active role in areas that could have been delegated. Production meetings occurred every day in 1998, a reactive response to the pressures of the increased goal. The Enlisted Programs Officer, an important hub in the recruiting process, attended upwards of seven meetings in a five day workweek, all of which required significant preparation time. Additionally, the EPO performed an inordinate amount of administrative paperwork for a department, not having the resources to be able to delegate these responsibilities. The CR and EPO also spent more time on accession goal than they could on production. With the focus on shipping, production suffered. Training on sales and DEP management also fell by the wayside as the recruiters were more concerned with finding “immediate-ships” than they were in building up their DEPs.

99-00: YES. The process improvement effort developed more effective procedures. The district clearly used the latest technology available to achieve that end.

Are tasks that are poorly understood or require creativity and innovation handled by organic structures?

97-98: YES. These tasks included methods of achieving the success factors: accession goal management, improved quality of life, and reduced improprieties were developed by the command leadership. No outside consultation was requested or required.

99-00: YES, but...not effectively. It was true that creative ideas came from the recruiters and the leadership. However, it came to a point where the new ideas were not allowed to prove their worth before one of the leaders would come up with another idea. These new ideas tended to decrease rather than increase efficiency and effectiveness.

Structure

Are tasks and functions done adequately with minimal overlap?

97-98: NO. The recruiters, zone supervisors and CR were not producing contracts as effectively as they potentially could have. The district and nation was concerned with accession goal, and settled for “good enough” when it came to NCO. When the nation achieved anything above 90 percent in NCO attainment, the belief was that the districts had earned an “A.” The districts followed suit. Unfortunately, the result was depleted DEPs and exhausted recruiters.

The EPDS was inefficient. He was a Chief Petty Officer who lacked leadership ability and imagination. MEPS was looked at as “the enemy” by the recruiters, and not as an ally. The MEPS developed a reputation for not only being inefficient, but for not being a team player.

The current ADMIN structure and methods were ineffective. Too much time was wasted on paperwork and the morale suffered. Having a CA was redundant. The XO and EPO could re-write their own correspondence. Having the district ADMIN department handling recruiting admin was not effective. The EPO needed its own ADMIN staff.

The SYSAD was used exclusively for repair and training, not innovation. The two members of this department trained the recruiters on how to use the R-TOOLS recruiting software and fixed broken laptops.

The PAO was retired on active duty. No one was available to write articles on the recruiters or to coordinate much needed positive-advertising campaigns.

The Zone Supervisors were not all trained and did not have extensive recruiting experience. Those that did have experience were not necessarily good leaders. Additionally, some of the zones were not expected to make goal, so they didn't.

The EPO was an administrator and tracker, not a leader. The EPO spent most of her time doing double work with evaluations. Overall, no delegation occurred. There was a lot of micromanagement, especially by the XO and EPO.

Unfortunately, there was too little time to innovate on the CO's watch.

99-00: YES. Most of the redundancy problems were solved or improved by the 1999-2000 leadership. Administration, LEADS conversion, control of the shipping process were all recognized and improved by the leadership. DEP management was not clearly defined, however. As a result, there were several layers of DEP leadership with no one fully in charge.

STRUCTURE

People, Processes, Culture

Do members regard official rules and procedures as fair and sensible?

97-98: YES and NO. The recruiters felt that they were being stretched to the limits with accession goal and reaching 90 percent, to try to always 100 percent for the district would be even more. On the contrary, those recruiters who strived to make NCO did not like the fact that others who were not making goal were not being held accountable for what they perceived as “failure.”

99-00: YES, most recruiters felt they were fair. Those in “difficult” stations were sometimes discouraged, however. Their attitude quickly changed when they were viewed by the rest of the recruiters and the leadership as using their difficult markets as excuses for not making goal. The culture of the district did not tolerate complainers.

Do reward and control mechanisms encourage behavior and group norms that are compatible with managerial objectives?

97-98: YES. The primary mission was to make accession goal. If the district did this, then there was no punishment. The district did not stretch to achieve NCO, which precluded any “risk-taking” to go the extra mile. Finally, the recruiters were rewarded if they did not do anything ethically wrong.

99-00: YES. The recruiters, for the most part, valued awards for performance. More importantly, most appreciated being awarded in front of their peers. The quarterly awards ceremonies were very popular with the recruiters, especially those who knew they were going to win an award. On the contrary, many recruiters felt inspired or motivated by not winning an award. That is, not winning made them try harder to win. Every recruiter also competed on an equal footing. Even though their station was not historically a powerhouse, the awards system was organized and written so that all

stations and all recruiters had an equitable chance to win awards. As well, the individual recruiter, especially if he or she was a Petty Officer second class, was motivated by the possibility of REIP. The district made it clear that REIPS were given out to those who not only wrote contracts, but displayed a whole sailor concept of excellence. Therefore, even those recruiters who were assigned to lower production stations could compete with the big number writers in the “power” stations.

Technology, Environment

Are the structures of the organization differentiated enough to allow them to handle their special problems created by their particular environments, technologies, and tasks?

97-98: NO. The zone supervisors could not autonomously handle problems as much as they wanted. The CR wanted them to, but realized that many of them could not be trusted or could not handle the responsibility.

The EPO did not run her department with autonomy. The XO constantly inquired about admin and personnel issues while the CO “rode her back”¹⁶² on production issues.

The CR had to deal with dissension amongst her zone supervisors which prevented effective problem-handling. Some of the zone supervisors did not respect the CR and her ability, so they did not cooperate.

99-00: YES, almost every sub-organization was autonomous. The Enlisted Programs Department operated with the complete confidence of the Commanding officer. Many process re-structuring decisions were made and implemented within the department in the areas without the CO’s prior approval. The Chief Recruiter was allowed to run the enlisted recruiting effort without any micro-management from the EPO or CO. The MEPS, in turn, was managed by the EPDS with expert efficiency. The EPO and CO trusted the EPDS to use his 35 years of experience to change many outdated processes and make decisions on day-to-day issues.

¹⁶² Anonymous Zone Supervisor, corroborated by anonymous headquarters personnel, November 2002.

Technology, Processes

Does the physical and geographic layout of the organization contribute to the flow of work and information?

97-98: NO. As with all districts, the geographic layout of the organization detracts from the flow of work and information. With stations as much as five hours away by car and no airport access, the geographic layout hinders the flow of information and of work. Said one recruiter,

It's disheartening to drive all the way to MEPS to put in an applicant you thought was fully qualified and then have the Doctor or one of the processors tell you that he or she is not. Then we have to take that long drive back, trying to explain to the applicant how messed up our system is.

Recruiters from the northern areas faced constant traffic on the I-805, I-15, I-8 and I-5. Recruits and recruiters from Las Vegas had to deal with delays and crowded flights. There was also 2-5 hour one-way roadtrips from non air-accessible areas such as Victorville and Barstow and Lake Havasu.

99-00: NO. As with all recruiting districts, the geographic dispersion of the recruiting stations detracts from the work and information of the organization. However, the 99-00 leadership recognized this and made every effort to improve connectivity.

People, Processes

Were group actions and decisions free from bitter conflicts or power struggles?

97-98: NO. There was dissension between some members of the upper leadership. Although not visible to the field, headquarters personnel were well aware of the personal conflicts occurring with the leaders. Many were indirectly forced to side-track their business with the leaders if an argument was occurring.

99-00: YES and NO. There were minor power struggles regarding accessions issues between the Senior Classifier and the CR. As well, there were some production conflicts between the MEPS and the Recruiters; and more specifically, between the EPDS and Zone Supes/Recruiters Rivalry. However, these conflicts did not get in the way of production and were quickly extinguished.

Did rewards and controls encourage desirable competition?

97-98: NO. The recruiters that were assigned in the non-producing zones did not believe they had a chance to win awards. As well, the headquarters and MEPS personnel felt segregated from the recruiters when it came to awards. The focus of the awards instruction was on the recruiters.

99-00: YES. The headquarters staff still believed that the recruiters hoarded all the awards, but to a lesser extent. The command established new awards including “Support Person of the Month” and the “Heavy Hitter” award, which was open to all personnel to recognize everyone in the district. However, some of the MEPS personnel still felt that they “were short-changed”¹⁶³ with awards because 80 percent of the awards budget was spent for recruiters. To alleviate this, MEPS personnel were eligible for the Support Person of the Month Award.

Do people and units have enough power and resources to accomplish their tasks adequately?

97-98: NO. The recruiters were behind the times in technology and communication. Communication and transportation was slow. The recruiters often had to wait for a vehicle to come back to their station to transport an applicant because there were so few cars to go around. In order to make a phone call, the frustrated recruiter had to either go to a recruiting station or a pay phone.

99-00: YES. The command and CNRC made a concerted effort to ensure that the recruiters had the resources available to successfully accomplish their tasks. CNRC increased the number of government vehicles, approved a budget for cell phones, increased the number of REIPS, re-structured it’s reward process to incentivize making NCO goal and improved morale by introducing such programs as Remote Delayed Entry Program, DEP Enrichment and reformed waiver policies.¹⁶⁴

Figure 3.23 provides a comparison of the Harrison Summary of Fit Analyses for the district in 1997-1998 and 1999-2000.

¹⁶³ MEPS Personnel, November 2002.

¹⁶⁴ CNRC reduced the level of waiver approval on some waivers from the CNRC level to the Commanding Officer level.

			1997-1998		1999-2000	
Focal Area	Fits with?	Analysis Query	Answer / Score		Answer/ Score	
Human Resources	S T Pr	Did employees' skills and training fit their job requirements?	NO	0	YES	2
		Were the best people attracted and retained by the rewards and advancement opportunities offered?	YES & NO	1	YES & NO	1
System Direction	R	Were the organization's strategies and programs be supported by available resources?	YES	2	YES	2
	E	Did the organization's strategies, tactics and objectives help it gain and maintain a favorable position in its environment?	YES & NO	1	YES	1
	Pr C	Did management express its purposes in ways that create a sense of mission and identity among members?	YES	2	YES	2
		Were efforts to change the organization compatible with current norms, behavior and assumptions?	YES & NO	1	YES	1
C Pr	Did managerial plans and objectives contribute to work, or were they too inflexible to handle unforeseen developments?	NO	0	YES	2	
Processes	S C	Were those people who must work together closely grouped in units or otherwise linked structurally?	NO	0	YES	2
		Were the procedures for coordinating work and information flows appropriate for the tasks and the technology?	NO	0	YES	2
		Were task that are poorly understood or require creativity and innovation handled by organic structures?	YES	2	YES	2
	S	Are tasks and functions done adequately with minimal overlap?	NO	0	YES	2
Structure	Pe Pr C	Did members regard official rules and procedures as fair and sensible?	NO	0	YES & NO	1
		Did reward and control mechanisms encourage behavior and group norms that were compatible with managerial objectives?	YES	2	YES	2
	T E	Were the structures of the organization differentiated enough to allow them to handle their special problems created by their particular environments, technologies and tasks?	NO	0	YES	2
	T Pr	Did the physical and geographic layout of the organization contribute to the flow of work and information?	NO	0	NO	1
	Pe Pr	Were group actions and decisions free from bitter conflicts or power struggles?	NO	0	YES & NO	1
		Did rewards and controls encourage desirable competition?	NO	0	YES	2
Did people and units have enough power and resources to accomplish their tasks adequately?		YES	2	YES	2	
TOTAL POINTS				13		30

Key:S-Structure T-Technology Pr-Processes R-Resources E-Environment C-Culture Pe-People

Figure 3.23. Comparison of Checklist of Fit Analyses: NRD San Diego, 1997-1998 and 1999-2000.

IV. CONCLUSIONS AND RECOMMENDATIONS

A. CONCLUSIONS

According to the Checklist of Fit Analysis and the assigned scores, the 99-00 district performed more effectively and efficiently as a system than the 97-98 district. There were notable similarities and differences in the two systems.

1. Similarities

Both districts considered themselves successful. The System direction established by the leadership of both districts appeared very effective. As well, success factors were clearly defined and obtainable. System direction fit with the available resources, the environment, the processes, and culture of each district.

The environment in 97-98 did not demand the attainment of New Contract Objective (NCO). With most districts struggling to make accession goal, NCO goal was considered “nice to have” but not necessary. NRD San Diego thus focused its effort on making monthly accession goal, which it did the entire two years. San Diego was CNRC’s bronze award winner as the third best district in the nation in 1998, and silver award winner as the second best district in 1997.

There was a renewed interest in making NCO goal in 1999. Diminished DEP pools forced CNRC to impose new requirements for NCO attainment as well as shipping goal attainment. CNRC realized that without a large DEP, accessions and thus the bootcamp population would decrease. Although (as a whole) CNRC did not make NCO for most of 1999 and 2000, individual districts like San Diego, Los Angeles and New York consistently achieved monthly NCO goal. NRD San Diego missed NCO in October of 1998 (1st month of FY1999). The district has made every monthly NCO since to date. With the increase in NCO came a larger DEP pool. The larger DEP pool resulted in increased accessions. Therefore, San Diego has also made every monthly shipping goal since then. The transformed 1999 district earned CNRC’s gold award as the number one NRD in the nation. The district then followed that up with a repeat gold award in FY2000.

Both districts had little to no control over assignment/selection of incoming recruiters. Fleet personnel, either voluntary or non-voluntary, made up the bulk of the recruiting force. Volunteers were attracted by the rewards and advancement opportunities of recruiting. Non-volunteers simply had no choice. The only difference between the two systems is that the 97-98 district received a larger percentage of recruiters after FY97 than usual as a result of CNRC's effort to increase the total population of recruiters to 5000.

There was identifiable tension between the recruiters and support personnel in both time periods. The structure did not fit with the people, processes and culture. Members did not generally regard official rules and procedures as fair and sensible. Headquarters personnel felt as if they were, as one member put it, the "red-headed step child" of the district. With the emphasis on contracts; all rewards, goals and success factors were geared towards the recruiters.

The recruiters in both districts performed up to the established expectations. The structure fit with the processes, people and culture. The reward and control mechanism encouraged behavior and group norms were compatible with managerial objectives. Although NCO was important to the 97-98 district, accessions were the overriding concern. Many recruiters were not overly concerned about missing NCO. The 99-00 district was expected to make all goals, and the processes developed appeared to positively impact the culture of the district. NCO was now expected and making NCO was rewarded.

Each district operated with relatively the same amount of resources. The people of each system appeared to have enough power and resources to accomplish their tasks adequately. The 97-98 district had relatively less goal than the 99-00 district. The 99-00 district had more people and more resources to achieve the higher goal.

2. Differences

The people in the 97-98 system appeared less capable to perform their duties than those in 99-00. The recruiters' skills and training did not appear to fit their job requirements in 97-98. These recruiters appeared ill-prepared for the large goal increase. They were predominantly non-volunteers assigned into recruiting by the Navy. The 99-

00 personnel appeared more seasoned and experienced. There were a greater number of voluntary recruiters as well. The recruiters who enjoyed smaller goals that could not cope with the increased requirements had departed the command. The leadership had the time to re-engineer processes to encourage development of a new culture as well. CNRC also gave the 99-00 district more resources to perform their duties.

The 99-00 district leadership's increased flexibility appeared to positively affect management of unforeseen change. In other words, the system direction fit better with the culture and processes in 99-00, than in 97-98. The 97-98 district was filled with individuals, both in leadership and in the ranks, who adamantly stuck by traditional methods and processes. They appeared to believe that doing things the old way would still be effective in the new environment. The 99-00 leadership realized the shortcomings of the "old ways" and feverishly developed new processes.

The method of system direction were vastly different in each district. The 97-98 district used less imaginative ways of providing direction, while the 99-00 district employed metaphors, incentives and visions.

Accountability was also more pronounced in 99-00. Missing NCO was not an option, and those individuals, stations and zones that did miss goal had to personally explain why to the Chief Recruiter, Enlisted Programs Officer and Commanding officer. In the previous command, zones and stations that tended to always miss goal were indirectly *allowed* to miss. That is, those recruiters, RINCS and zone supervisors in the historically difficult areas were given latitude when it came to NCO.

Communication and structure improved in 99-00. Technological advances, flatter lines of communication, and less rigid organizational structures contributed to better performance in the 99-00 organization. The 97-98 district operated with older technology, hierarchical communication flows and a rigid command structure.

The 97-98 NRD processes appeared more redundant and inefficient. The structure of the 97-98 district did not fit well with the processes. The administration, DAR and FITREP/EVAL process improved in the 99-00 district. New positions such as the Public Affairs Strike Team and Enlisted Processing Officer further improved command performance. Eliminating such positions as the Chief Administrator prevented

overlap in several processes. The re-structuring of the LEADS and MEPS department in 99-00 were also instrumental in improving the command's performance.

99-00's organizational structures were more autonomous. Everyone was under the microscope in 97-98. Organizations within the district, such as specific zones, MEPS and each department, were not allowed to handle special problems on their own. The 99-00 command encouraged taking care of problems at the lowest level possible. Of course, serious problems such as ethical misconduct were handled at the highest level. However, possible improprieties and minor investigations were handled at the lower levels.

The 99-00 awards system appeared to spark increased competition in 99-00. The culture of 99-00 placed an emphasis on "winning." Winning equated to NCO achievement. The awards system rewarded NCO achievement. As a result, competition increased among all the individual recruiters, stations and zones. In 97-98, competition was heavy only among those zones and stations that were located in historically productive markets. The other zones and stations simply appeared more apathetic and did not appear to try as hard.

The emergent cultures were different. One of the most notable differences between the 97-98 NRDS and the 99-00 versions were the cultures. The norms and values evolved from a district that seemingly was "afraid to recruit" and afraid of reprisal to one that wanted to recruit and savored success. As one recruiter put it, the district went from "being 'hit and miss' to never missing."

"The way they did things" was different causing attitudes and expectations to be different. The expectation was different. Motivational factors were different. The culture appeared to facilitate integrated effort. The relaxed conditions, coupled with the seemingly innate drive and energy of the recruiters and the command, led to the remarkable results already discussed.

There was also a greater sense of teamwork amongst the recruiters. Although competition was fierce, the recruiters viewed each other more as "family, than

competition.”¹⁶⁵ The zone supervisors “were always on the same page” and to a person, completely respected the CR’s leadership and recruiting ability.¹⁶⁶

There was more delegation of duties in 99-00. The EPO delegated several significant jobs to his Chief Recruiter, Assistant EPO, the EPO Administrator, the EPDS and Statistician. The Commanding officer and Executive allowed the EPO to handle many procedures they previously performed such as waiver interviews, accession management, FITREP processing and DEP leadership.

B. RECOMMENDATIONS

NRD San Diego should continue to evaluate and improve methods of system direction, critical success factors, processes/subsystems, structure/organization and use and procurement of technology to ensure that a productive and positive culture emerges, thereby improving the chances for overall success.

The command should allow its sub-organizations to operate with as much autonomy as possible. This promotes trust and confidence within the organization and reduces the negative stigma of micro-management.

The command should continue to encourage delegation and training of its more junior members in order to develop a technical knowledge-base and instill leadership in each of its members.

NRD SD should continue to improve its relations with external political, academic and social organizations to better fit with its environment.

The district should extensively invest in leadership training to promote a continual line of effective leaders and managers.

The command should continue to emphasize New Contract Objective as the primary goal. Making NCO appears to lead to better quality of life and healthy competition, and appears to help ensure the district makes accession as well.

As of January 2003, NRD San Diego has continued its streak of months making NCO and Shipping goal. The “streak” is up to 51 straight months. The command was

¹⁶⁵ Recruiter, October 2001.

¹⁶⁶ Zone Supervisor, November 2002.

also awarded a third straight District of the Year Award in 2001. With continuous process improvement, an emphasis on goal attainment and energetic and innovative leadership, Navy Recruiting District San Diego should maintain its stature as the premier district in the nation.

APPENDIX A. LIST OF INTERVIEWEES, PERSONAL COMMUNICATIONS AND CONVERSATIONS

NRD San Diego

Commanding Officers, 99-00
Executive Officer, 99-00
Chief Recruiters, 97-00
Enlisted Programs Officers, 97-00
Assistant Enlisted Programs Officer, 99-00
LEADS Supervisors, 97-00
Executive Secretary
Zone 1 Supervisor
Zone 2 Supervisor
Zone 3 Supervisor
Zone 4 Supervisor
Zone 5 Supervisor
Zone 6 Supervisor
District Trainer
DEP Coordinator
Systems Administrator
Chief Petty Officer Urbiztondo, NRS Imperial Beach
Petty Officer King, Recruiter, NRS Chula Vista
Petty Officer Briones, Recruiter, NRS Clairemont
Petty Officer Jordan, NRS Chula Vista
Petty Officer Hanson, NRS Victorville
Petty Officer Erceg, NRS Victorville
Petty Officer Gunn, NRS Riverside
Ensign Mercado, NRS National City
Chief Petty Officer Roth, NRS National City
Chief Petty Officer Beck, Headquarters
Chief Petty Officer Chambers, NRS Oceanside
Chief Petty Officer Luciano, NRS Hemet
Petty Officer Heurtelou, NRS National City
Chief Petty Officer Adams, NRS Chula Vista
Petty Officer Caballero, NRS Garden Grove
Petty Officer Manansala, NRS Mira Mesa
Petty Officer Su, NRS Garden Grove
Chief Petty Officer Reed, Region West
Petty Officer Long, NRS Las Vegas West
Petty Officer Medders, NRS Henderson
Petty Officer Gresens, NRS Victorville
Chief Petty Officer Maher, NRS Hemet

THIS PAGE INTENTIONALLY LEFT BLANK

APPENDIX B. INTERVIEW PROTOCOL*

This interview is being conducted as part of the research for my masters' thesis. I am conducting an organizational analysis of NRD San Diego. The primary purpose of my research is to analyze the structure, processes, information systems, and both internal and external relationships of both organizations over the years 1997-2000. More specifically, I am interested in the organizational differences in the district between the periods 1997-98 and 1999-2000.

The results of this interview will be used to compare the similarities and differences of the two districts. Anything said will be cited unless you request it remain confidential and/or anonymous. I would like to record this interview.

Background

1. What is your career background?
2. How long have you been in this position?
3. Are you a non-volunteer or volunteer recruiter?
4. Have you had any previous recruiting experience?
5. If you were here in 1997, generally compare and contrast the district back then to how it is now?

Mission and Structure

6. What, in your opinion, is the overall purpose of NRD San Diego?
7. What are your responsibilities?
8. What would you say are the "inputs" of the organization in terms of history, information and resources?
9. What would you say are the "outputs and outcomes" of this organization?
10. Who depends on these outputs?
11. How does this organization compare to other naval commands; how is it different? The same?
12. What individuals or organizations have an impact on getting your job done?
13. How are decisions made?

* Interview protocol was a basic framework. Actual interviews were tailored towards the interviewee.

14. Would you describe your organization as being autonomous or is it an organization with a lot of interdependence on other agencies?
15. How do you spend the majority of your time during a typical day?

Technology

16. How do you communicate with each other?
17. What are the information systems used by this organization?
18. Are you able to get the information you need in order to make decisions?
19. What information would you like to see that you aren't able to now?

People and Rewards

20. Besides NORU, what other training have you received?
21. How long would you say it takes someone to learn how to become an effective recruiter?
22. Is turnover problem in this organization?
23. Are the awards and compensation systems in place enough to motivate you in performing your job? What are the rewards and compensations?
24. How would you define success?
25. What are the reasons for the command's success/failure?
26. How would you describe the culture of the organization?
27. How has leadership contributed to the culture of the command?
28. How are you rewarded for your success?

Miscellaneous

29. If you were CO for a day, what would you change in this organization?
30. Why are other districts better/worse than you? Why?
31. What would you say are the most significant processes that occur here?
32. Is there anything else you'd like to add?

APPENDIX C. SAMPLE GOALING LETTER 99-00

From: Commanding Officer, Navy Recruiting District San Diego
To: TEAM SD

Subj: GOALING LETTER, FEB 2000

1. HAT'S OFF TO THE FINEST TEAM IN THE NATION! Your fantastic effort in January got the ship underway a day early. When all was said and done, you achieved 106 percent of NCO, number one in the nation! You wrote an impressive 242 net contracts. You hit 104 percent A-CELL, 182 percent PUMG, 111 percent CRITS, 100 percent NUKE and a remarkable 185 percent WF mission. Currently, 29 stations are at 100 percent FY goal and 9 stations are above 85 percent. All zones are at 100 percent! Remember...our true goal this year is every station, every zone.
2. Once again, you made shipping goal for the nation last month. Not only did you ensure The district made our original goal of 177, you easily delivered on an extra 19 requested by AREA. Your tireless dedication to writing workforce contracts resulted in over-shipping for the month of February (by 40 to be exact). The DEP Slopes for March, April and May are steep; but as always, I trust you will all meet the challenge head on.
3. The new contract goal this month is 238. Continue to start strong and do it right by making the early gates. As shown in the last couple of months, you avoid the frenzied, high-volume Mission Days (and Nights) by making 25 percent and 50 percent gates. I must also emphasize that we need male and upper female contracts. As you may know, The district have almost no female lower seats for the remainder of the fiscal year. Lower females will be processed for physicals only and may be brought back at the end of the month if the seats are available.
4. I'd like to bring up three important points regarding DEP leadership:
 - a. First, I applaud your effort to identify attrites early. Doing so has given you a clear picture of your true DEP posture.
 - b. Second, an outstanding tool is now available to you to maintain the morale and enthusiasm of your deppers. The Fleet Mentoring program is up and running but needs your energy to make it effective. If you have a depper who would like to know more about his/her rating, please contact the EPO ASAP. There may be a mentor who can "show the ropes" to your depper.
 - c. Finally, treat your deppers with dignity and respect. If you believe you have an RTO that needs to speak with me, please let the CR know immediately. I am willing to speak to an RTO if you believe that depper needs some re-affirmation of his/her commitment.
5. Through NALTS, local LEADS and RTC referrals, LEADS was responsible for 45 percent of New Contract Objective for January. Our Leads Team is #2 in the nation and is about to overtake the lead. You are within standards both with

national and local leads. Make no mistake, there is a direct correlation between LEADS success and district success. Keep using those Leads!

6. You are truly the best recruiters in the nation. You have proven your skills beyond refute. You have displayed your grit beyond belief. You've demonstrated a tenacity and enthusiasm that all districts should emulate. Not so long ago...last January to be exact, the district had to write 50 contracts on the last day. This month, you ended up with almost 50 DDD's! And because we are forward thinking and because we believe in quality of life, I will do my best to roll up some goal from June into May so that you can better enjoy the summer months. Keep on keepin' on Team SD. You're rolling way past District of the Year Standards and living up to your billing as the "Best of the Best!"

CO

"I believe I can fly!"

APPENDIX D. (EXCERPT FROM) SAMPLE EPO PASSDOWN LOG 99-00

EPO PASSDOWN LOG, 14 DEC 2000

I'm gonna try to make this short because I've heard some complaints about the lengthiness of these passdown logs. In fact, a certain Senior Chief said "it's hard to read because it's too long..." When I told this Chief Woods, his response was..."The real reason it's hard for Senior Chief to read because he doesn't know how to read...somebody has to read it to him." Now...I'm not trying to make fun of anybody's learning deficiencies or anything like that, I'm just repeating what Chief Woods said to me on 28SEP at 1432 PM on my cellphone while I was driving to MEPS. Anyway, let me continue with the final PDL of FY99:

The CO said it best: **"Losers quit when they're tired, winners quit when they have won."**

The stats say it 2nd best:

- #1 in NCO attainment.
- #1 in Accessions to bootcamp.
- All Zones made FY goal!
- 33 of 41 stations made FY goal.
- **LVWEST, REDLANDS, COLLEGE GROVE, SANTEE, BULLHEAD CITY and ORANGE** made up their FY deficits in September and made FY Goal. They battled until they won.
- **Zone 2 made a spectacular comeback! And not only locked out early, but made up an 8 contract deficit to make FY goal!**
- Every zone made all wickets except for one that missed Nuke, although they had enough to write, but PRIDE and CNRC would not let us...so I consider them making it. **That's...ALL WICKETS!** Think about it, that's amazing!
- **Zone 3** wrote over 858 gross contracts...damn!
- **LVEast, Chula Vista, El Cajon, El Centro, Victorville, and National City never missed monthly goal.**
- Zone 6 and Zone 4 made FY goal, the first time in a long time they have done that.
- Zone 5 made all months, except for one month where they missed by a gnat's you know what, well.
- PO McCormick wrote 9 NCO's. PO King wrote 9 NCO's. PO Briones wrote 7 NCO's. PO Gresens wrote 7 NCO's. PO Culpepper wrote 5

NCO's. PO Ferrari wrote 6 NCO's. PO Ramos wrote 5 NCO's. PO Lorenzo wrote 5 NCO's. HT2 Johnson wrote 5 NCO's. Damn...

I'm proud of each and every one of you, and please, please forgive me if I miss you, but these are some things I will remember about this FY:

- How the CR and I came back from goaling conference last year with a, as she says it "pretty dern high goal" but we both knew that you all could make it. And as she said "they sho did, huh."
- How we rolled up over 70 DDD's and then someone came up with the bright idea of not letting us keep them...but you wrote them nonetheless.
- Visiting Zone 4 for the first time and seeing how fired up they all were...even though the conditions over there are sometimes unbearable. But they still looked sharp in their uniforms, even though they were uncomfortable.
- Meeting PO Hansen and him telling me " Can you say...I'm gonna blow up this year EPO" and he did. And he plays a good game of golf too.
- The then XO (CDR Wynne) looking me in the eye at the end of last FY, saying..."We know your guys were good last year...the best...But this year, We want you to help me instill in them the idea of
- TEAM. That we want to be winners only for each other and for the TEAM."
- Petty Officer Suh and I screaming at the top of our lungs on the speaker phone talking about some crazy things, like his two hour commute from Chula Vista to Garden Grove every day.

In fact I love you all and I'm looking forward to another great year. There's only one direction TEAM SD is going...and that's UP. We've got essentially the same goals this year. You've had a whole year to figure out how to do it...you should put it in another gear. I asked you to leave no doubt about who was the best and you did. You put in the extra effort, stepped on the gas a little bit more, and came out on top. You have proven time and time again that with a little sweat, a lot of talent and whole lot of heart, you can do anything. You are the best! You are the best! You are the best!

Feels Nice at the Top don't it?
Feels Great in the Winner's Circle as well.

I'll say it again in case you forgot:

"There ain't no team like the one I got"

Happy New Year Team SD!

Very Respectfully,
EPO

LIST OF REFERENCES

- Berryman, Reba, "Systems Thinking and Organizations: An Initial Inquiry into the Subject (CSWT Papers)", downloaded from <http://www.workteams.unt.edu> on November 21, 2002.
- Bruner, Bradley D., *An Organizational Analysis of the Military (Navy) Personnel Plans and Policy Division (N13)*, Master's Thesis, Naval Postgraduate School, Monterey, California, 1998.
- Buchele, Robert B., *The Management of Business and Public Organizations*, McGraw-Hill:New York 1977.
- Gibson, J. and others, *Organization: Behavior, Structure, Processes, Business Publications*: Plano, Texas 1982.
- Hagberg, Richard and Heifetz, Julie, "Corporate Culture/Organizational Culture: Telling the CEO that his/her Baby is Ugly," Downloaded from <http://www.hcgnet.com/html/articles/understanding-culture.html>, 2002, p. 2.
- Harrison, Michael I., *Diagnosing Organizations: Methods, Models, and Processes*, Sage Publications: London, 1987.
- Hirabayashi, Donna M. and Stein Hersh, Roberta, *Excellence in Navy Recruiting: A Look at High-Performing Navy Recruiting Districts*, Master's Thesis, Naval Postgraduate School, Monterey, California, 1985.
- McNamara, Carter, McNamara, Carter, "Thinking About Organizations as Systems," from http://www.mapnp.org/library/org?thry?org_sytm.htm, downloaded 10/18/2002.
- Muchinsky, P., *Psychology Applied to Work*, Brooks/Cole Publishing: Pacific Grove, California, 1997.
- Nadler, D. and Tushman, M., *Strategic Organizational Design*, Scott Foresman and Company:Glenview, Illinois, 1988.
- Navy Recruiting Command Organization Manual, COMNAVCRUITCOMINST 5400.1F.
- Navy Recruiting Manual, Commander, Navy Recruiting Command (CRUITMAN), COMNAVCRUITCOMINST 1130.8.
- Schein E., *Organizational Culture and Leadership: A Dynamic View*, Jossey-Bass: San Francisco, 1985.
- Senge, Peter, *The Fifth Discipline*, Doubleday: New York, 1990.

- Simon, C., "The Systems Model and Organizational Analysis," Briefing at Naval Postgraduate School, August 2002.
- Simon, Steven I., "Measurement as a Transformative Tool: the Culture Assessment", downloaded from <http://www.camcoderinfo.com>, October 2002.
- Standard Organizational Manual, Navy Recruiting Command, CNRC SORM.
- Standard Operations Procedure Manual, Navy Recruiting Command, CNRC SOPMAN.
- Wagner, J. and Hollenbeck J., Organizational Behavior: Securing Competitive Advantage, Prentice Hall: Upper Saddle River, New Jersey 1998.
- _____, "Introduction to Enlisted Programs", Navy Recruiting Orientation Unit.
- _____, Navy Recruiting District San Diego Historical Performance from CNRC Statistics (Mr. Noble).
- _____, Commander, Navy Recruiting Command Historical Performance from CNRC Statistics (Mr. Noble and Mrs. McCleod).
- _____, "The Systems Model" (Unpublished), Naval Postgraduate School, Monterey, California.
- _____, "A Systems Model of a Business Firm," downloaded from <http://www.csc.ncsu.edu/degrees/undergrad/Reports/jfganawa/model3.html> on October 10, 2002.

INITIAL DISTRIBUTION LIST

1. Defense Technical Information Center
Ft. Belvoir, VA
2. Dudley Knox Library
Naval Postgraduate School
Monterey, CA
3. Director, Navy Staff
Office of the CNO
Washington, D.C.
4. Commander, Navy Recruiting Command
Navy Recruiting Command
Millington, TN
5. Dr. Cary Simon
Naval Postgraduate School
Monterey, CA
6. CDR William D. Hatch II
Naval Postgraduate School
Monterey, CA
7. LCDR Romuel B. Nafarrete
Naval Postgraduate School
Monterey, CA
8. Capt. Ray Wynne
Navy Recruiting Command
Millington, TN
9. Commander, Navy Recruiting District San Diego
Navy Recruiting District San Diego
San Diego, CA