



Calhoun: The NPS Institutional Archive
DSpace Repository

NPS Scholarship

Publications

2002-08

Overview of the NPS Spacecraft Architecture and Technology Demonstration Satellite, NPSAT1

Sakoda, Daniel; Horning, James A.

16th Annual AIAA/USU Conference on Small Satellites
<https://hdl.handle.net/10945/30339>

This publication is a work of the U.S. Government as defined in Title 17, United States Code, Section 101. Copyright protection is not available for this work in the United States.

Downloaded from NPS Archive: Calhoun



Calhoun is the Naval Postgraduate School's public access digital repository for research materials and institutional publications created by the NPS community. Calhoun is named for Professor of Mathematics Guy K. Calhoun, NPS's first appointed -- and published -- scholarly author.

Dudley Knox Library / Naval Postgraduate School
411 Dyer Road / 1 University Circle
Monterey, California USA 93943

<http://www.nps.edu/library>

Overview of the NPS Spacecraft Architecture and Technology Demonstration Satellite, NPSAT1

Daniel Sakoda and James A. Horning
 Naval Postgraduate School
 777 Dyer Rd., Bldg. 233
 Code (SP/Sd), Rm. 125
 Monterey, CA 93943
 dsakoda@nps.navy.mil
 ph.: (831) 656-3198; fax: (831) 656-2816

Abstract

This paper describes the overall design of NPSAT1, a low-cost, technology demonstration satellite which hosts a number of experiments. The command and data handling (C&DH) subsystem is built on commercial, desktop PC architecture, and standards-based specifications. Combining PC hardware and a PC/104 interface bus with the robust Linux operating system software offers a means of addressing the uncertainty and difficulty of managing space systems software. NPSAT1 will also demonstrate the use of nonvolatile ferroelectric RAM which is inherently radiation-tolerant. Lithium-ion polymer batteries are another state-of-the-art technology that will be employed offering high energy density for space applications. A novel, low-cost, low-power attitude control subsystem providing coarse, three-axis stabilization will also be implemented using only magnetic torquers as actuators and a three-axis magnetometer for sensor input.

Experiments on-board NPSAT1 include two Naval Research Laboratory (NRL) payloads: the coherent electromagnetic radio tomography (CERTO) experiment and a Langmuir probe. The CERTO experiment is a radio beacon which, in concert with ground station receivers, is used to measure total-electron-content (TEC) in the ionosphere. The Langmuir probe will augment CERTO data by providing on-orbit measurements. The other experiments are of NPS origin. These include a configurable processor experiment (CPE), a COTS visible wavelength imager (VISIM), and a three-axis micro-electromechanical systems (MEMS)-based rate gyro. NPSAT1 is manifested on the Department of Defense Space Test Program (STP) MLV-05, Delta IV mission, due to launch in January 2006.

Introduction

The Naval Postgraduate School (NPS), located in Monterey, California, is the graduate university for the Navy, educating officers from all services, as well as international officer students. The Space Systems Academic Group is the focal point for education and research efforts in space at NPS. Two space curricula are offered at NPS, Space Systems Engineering and Space Systems Operations. Education and research are married in the Small Satellite Design Program which uses spacecraft development as a vehicle for education, exposing officer students to the full life-cycle development of a space system while exploring the capabilities of low-cost, small satellites. Spacecraft in the NPS Small Satellite Design Program are Class D spacecraft per MIL-HDBK-343¹, defined as a higher risk and minimum-cost effort.

NPS is currently developing NPSAT1, the second small satellite to be built at NPS by officer students, faculty, and staff. NPS launched a small, digital communications satellite, PANSAT, aboard the *Discovery* Shuttle in October 1998^{2,3}. As a follow-on project, NPSAT1 builds on lessons learned from PANSAT, addressing 'bottlenecks' in the development process, and provides greater capability in the spacecraft bus to host a number of experiments while demonstrating innovative, low-cost spacecraft architectural elements for small satellites.

Mission Objectives

The main objective of NPSAT1 is to enhance the education of officer students at NPS. By providing hands-on experience working on an actual space system, officer

students are exposed to the realities of systems engineering and the processes inherent in the flow from initial requirements to flight operations. From the standpoint of education, the spacecraft is a by-product of the educational process. The satellite, itself, will provide a test bed for technology demonstration of commercial, off-the-shelf (COTS) components for space applications; and will provide an experiment platform for other science experiments.

Space Systems Education

NPS offers two curricula in space, Space Systems Engineering and Space Systems Operations. The Space Systems Engineering curriculum is typically a nine-quarter program resulting in a Master of Science in one of the engineering or science disciplines offered at NPS. The Space Systems Operations curriculum is typically an eight-quarter program resulting in a Master of Science in Space Systems Operations. Both curricula require a graduate thesis in a space-related topic. The small satellite design program, specifically NPSAT1, offers meaningful topics not only in spacecraft subsystem designs, but also in the design, development, and testing of the on-board experiments, and spacecraft operations.

NPSAT1 has been the topic of a number of classroom design projects, as well. The initial design concept was the topic of the capstone spacecraft design course for the Space Systems Operations class, AA4831, Spacecraft Systems II, which focused on the concept of operations and helped to identify potential issues. The attitude control subsystem design was given to the AA3818, Spacecraft Attitude, Dynamics, and Control course. The NPSAT1 orbit is studied in the SS2500, Orbital Mechanics course, to perform a coverage analysis of the camera; and the preliminary thermal analysis is used as a case study in the AA3804, Spacecraft Thermal Control course. In short, NPSAT1 offers a wealth of resources for the class room for understanding and solving real-world spacecraft design problems.

Spacecraft Technology Demonstration

The NPSAT1 architecture addresses some of the lessons learned from PANSAT which are by no means exclusive to university-built satellites. The software part of any space system is arguably the least reliable and most prone to cause schedule delays, and thus increases the cost of the program. A likely cause for delays and unreliability is the uniqueness of the space flight hardware as a computing platform. Because of this hardware uniqueness, software cannot be reliably tested until hardware becomes available on which to run and debug software drivers,

and control algorithms. The problem becomes more readily apparent as more autonomy is required of the spacecraft which in turn demands a more sophisticated operating system.

The NPSAT1 command and data handling (C&DH) subsystem addresses this issue by adhering to standards which are widely accepted in industry. This affords a design based on commercial, off-the-shelf (COTS) products. The goal of the NPSAT1 small satellite is to demonstrate a COTS-based C&DH subsystem using PC/104-compliant computer hardware along with a POSIX-compliant operating system, namely Linux. The PC/104 architecture is fully compatible with the desktop PC in a miniaturized configuration. The Linux operating system is a robust, multi-tasking operating system with a rich environment for the software developer. Combining the PC/104 hardware with the Linux operating system software offers the means by which software development carried out on desktop PCs is fully compatible with the target flight hardware. At NPS, this means officer students can work on software algorithms without the need to code at the hardware level.

NPSAT1 will also demonstrate other currently available COTS components which are directly applicable to space. One such example is ferroelectric (FERRO) memory. FERRO RAM devices are currently available in sufficient densities to allow for their use as a replacement of conventional, or RAD-tolerant RAM devices. FERRO RAM offers the inherent property of radiation-tolerance and offers nonvolatile memory storage. NPSAT1 will demonstrate the use of FERRO RAM as part of the spacecraft electrical power subsystem (EPS).

Another example of COTS components which would be advantageous for space applications is lithium-ion (Li-ion) rechargeable batteries. Li-ion batteries offer the highest energy density (Watt-hours per kilogram) than any of the currently used battery technologies, such as nickel-cadmium, nickel-hydrogen, or nickel-metal hydride. These batteries offer energy densities starting from 120 Watt-hours per kilogram and do not exhibit any 'memory effect.' Two types of rechargeable Li-ion batteries are available. NPSAT1 is investigating flying a Li-ion polymer battery which provides a safe battery cell in terms of damage due to overcharging, discharging or handling. However issues exist with regard to shelf life and manufacturing consistency that need to be resolved before a final decision is made on the spacecraft energy storage system.

Experiment Platform

NPSAT1 will host a number of experiments described in more detail in this paper. Two experiments will be provided by the Naval Research Laboratory (NRL). These are the coherent electromagnetic radio tomography (CERTO) experiment (a three-frequency beacon), and a Langmuir probe. Three other experiments originate from within NPS. These are a configurable processor experiment (CPE), and two COTS-based experiments, a three-axis micro-electromechanical systems (MEMS) rate sensor, and a visible wavelength imager (VISIM), basically, a digital camera. Finally, NPSAT1 will also serve as a flight demonstration of advanced, triple-junction solar cells with a solar cell measurement system (SMS) to individually measure current versus voltage (I-V curves) of 24 experiment solar cells. The NPSAT1 body-mounted solar cells will also be of the same type as the 24 experiment cells.

Spacecraft Description

NPSAT1 is a 81.6 kg [180 lb] satellite manifested on the Department of Defense (DOD) Space Test Program (STP) MLV-05 Delta IV mission due to launch in January 2006. NPSAT1 is one of five secondary payloads to share the Delta IV using the evolved expendable launch vehicle (EELV) secondary payload adapter (ESPA)⁴. The overall configuration is shown in Figure 1, with the top, side, bottom, and isometric views shown. Figure 2 shows an expanded assembly drawing of the spacecraft depicting modules located within the spacecraft. The spacecraft is a 12-sided cylinder with body-mounted solar cells on all

of the cylinder sides. Both ends of the cylinder have antennas mounted on them to allow for communications in the event the attitude of the spacecraft is not correctly nadir-pointing. This configuration assumes the risk, though remote, of an ACS failure combined with an attitude such that the cylinder longitudinal axis points at the sun in either the plus or minus sense for an extended period of time resulting in loss of solar panel illumination. Two deployable booms are shown which are the CERTO beacon antenna and Langmuir probe boom, respectively.

The spacecraft subsystems include the command and data handling (C&DH) subsystem, electrical power subsystem (EPS), attitude control subsystem (ACS), radio frequency subsystem (RFS), and mechanical subsystems which include the spacecraft structure, mechanisms, and thermal design. As a low-cost satellite, few space-rated components will be used, and the system will be a 'single-string' design. The spacecraft's circular orbit with altitude of 560 km and 35.4° inclination suggests a relatively radiation-benign environment. Total dose for the spacecraft electronics is estimated at 200 rad (Si) per year*. However, radiation tolerant devices will be used for critical areas, such as in the EPS micro-controller and memory, to mitigate the risk of single event effects (SEE). Within the EPS micro-controller, a watchdog timer will be used as a check that the C&DH processor is operating properly. Should the C&DH not reset the watchdog timer within a set time period, the EPS will cycle power to the C&DH forcing a reboot. Another design feature to be employed to mitigate SEEs is error-detection-and-correction (EDAC) memory in the C&DH. Figure 3 shows the system block diagram of NPSAT1.

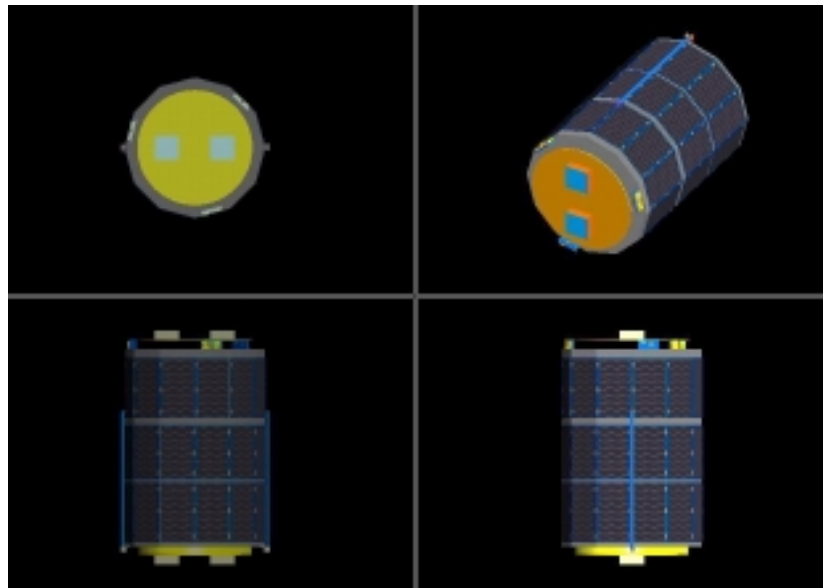

Figure 1. NPSAT1 Spacecraft Configuration.

3

* Due to trapped protons and assuming 300 mil aluminum shielding

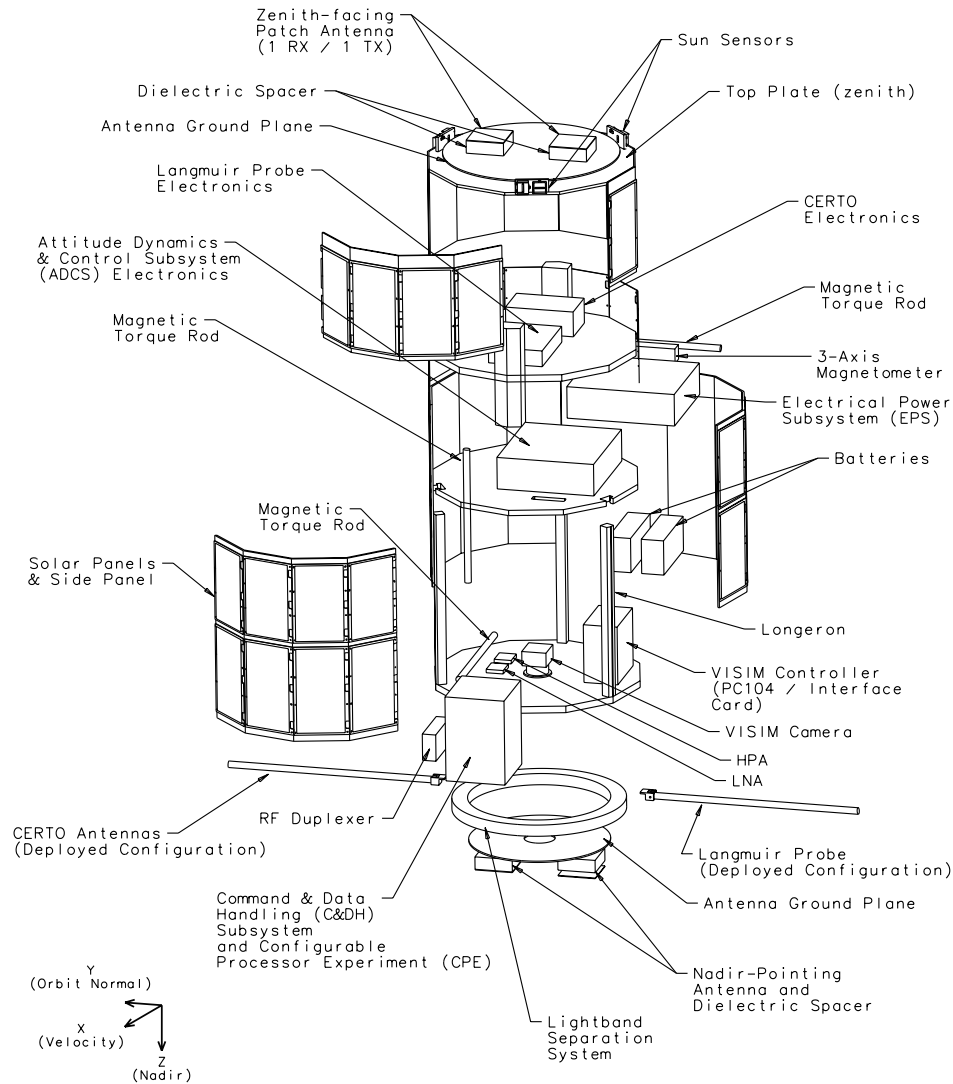

Figure 2. NPSAT1 Expanded View.

The spacecraft is intended to operate with a great deal of autonomy. Except for the RFS, each of the spacecraft bus electronics subsystems (C&DH, ACS, and EPS) has its own processor. The EPS and ACS, as well as the SMS experiment controller, are very similar in design taking advantage of design modularity. The C&DH performs the bulk of the scheduling of spacecraft and experiment operations. Because of limited available power, all experiments are required to be able to power off in order to save on electrical power while idle. The C&DH is, itself, capable of undergoing a 'deep sleep' mode to save power, essentially halting its instruction clock. Focusing on good power management ensures the maximum return of science from the experiments.

NPSAT1 Startup

NPSAT1 is designed to be powered off while attached to the launch carrier. This is done as a primary safety inhibit. Upon separation from the ESPA, power is provided through the solar panel bus to the EPS. The EPS then closes a MOSFET switch to put the battery on-line and powers up the C&DH and VISIM experiment. Powering up the VISIM is intended to capture pictures of the launch vehicle and the other secondary payloads. However, there is some latency in the VISIM controller to boot up, and tip-off rates may force the intended target out of view. The EPS then powers up the ACS where initial attitude acquisition is performed to null the rates. NPSAT1 then periodically listens for the NPS ground station using both the nadir-pointing and zenith-pointing antennas. Once

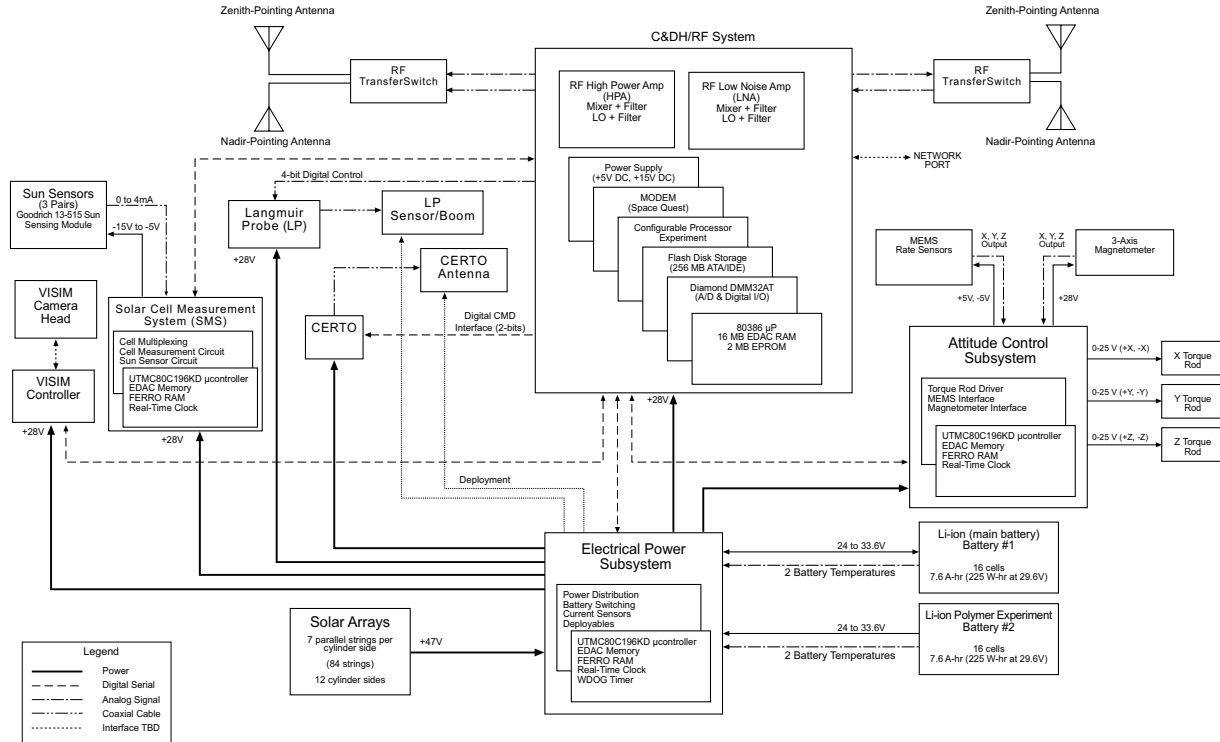

Figure 3. NPSAT1 System Block Diagram.

3 June 2002

NPS contacts the spacecraft, orbit ephemeris is uploaded, the real-time clock is synchronized, images from the VISIM are downloaded, and spacecraft telemetry is downloaded to determine initial spacecraft operations. At this time, the CERTO and Langmuir probe booms may be deployed by NPS command. With timely orbit ephemeris onboard, NPSAT1 can initiate normal-mode pointing in the ACS, where the CERTO and Langmuir probe booms are pointing in the plus and minus orbit normal, and the base of the spacecraft, where the camera is located, is nadir-pointing. On-orbit checkout of the NPSAT1 spacecraft bus is expected to take two weeks, after which experiment operations can begin. Figure 4 shows a flow diagram of the NPSAT1 startup procedure.

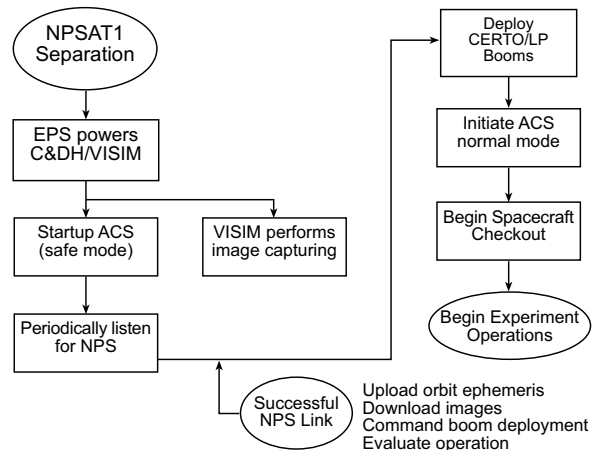

Figure 4. NPSAT1 Startup.

23APR2002

Subsystem Descriptions

Command and Data Handling (C&DH) Subsystem

The NPSAT1 command and data handling (C&DH) subsystem consists of several electronic boards which are attached using the PC/104 bus and housed within one large box. These boards are the C&DH motherboard, mass storage, A/D conversion and general purpose input and output (I/O), the configurable processor experiment (CPE), the power supply, the modem, and other radio frequency

subsystem (RFS) components. Figure 5 is a block diagram of the C&DH motherboard and its interface with the A/D I/O module, the CPE, and the mass storage.

The C&DH motherboard design is based off the PC/104 bus. PC/104 is a compact implementation of the standard PC bus, the industry standard architecture (ISA) bus, which provides hardware and software compatibility to the standard PC. The NPSAT1 C&DH incorporates most of the PC/104 electrical signals with a board size greater than the typical 3.6" x 3.8". Except for the need to con-

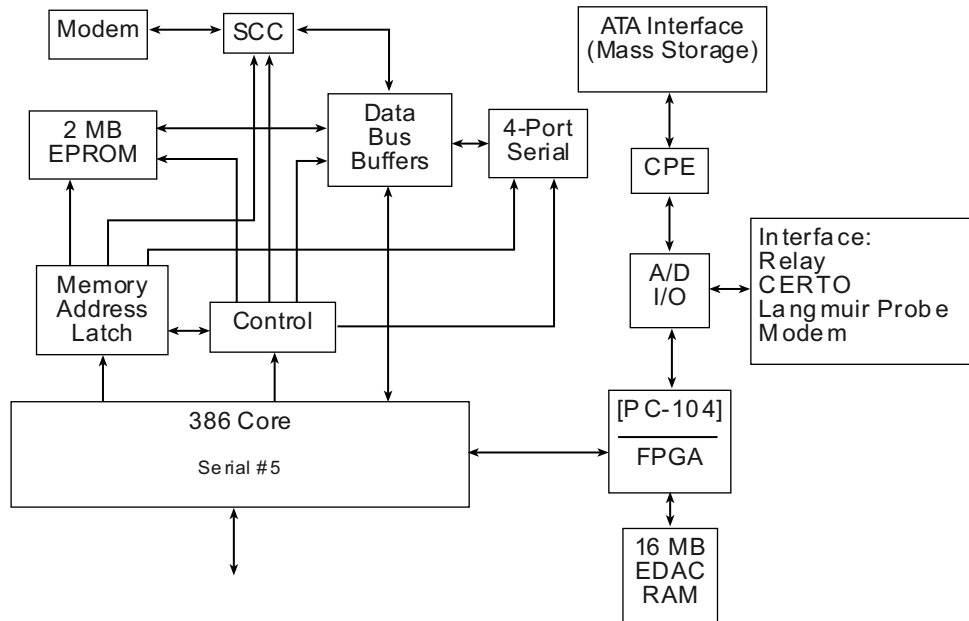

Figure 5. C&DH Block Diagram.

serve power and for Error Detection and Correction (EDAC) RAM, the NPSAT1 command and data handling (C&DH) subsystem could be implemented using a COTS-based PC/104 computer.

The C&DH uses a 386 microprocessor running at 33 MHz. There are 2 Mbytes of ROM and 16 Mbytes of EDAC static RAM. Five asynchronous serial ports, one port from the 386 and four using a multi-port module, provide subsystem communication and a network port for testing and integration. A serial communications controller (SCC) provides two bidirectional channels of synchronous serial in which one channel is used as the interface to the spacecraft modem. A field programmable gate array (FPGA) implements the PC/104 bus and the EDAC controller. The EDAC is one-bit correctable and two-bit detectable and based off of the design used by PANSAT⁵.

The mass storage is a COTS AT Attachment (ATA) interface, also known as integrated drive electronics (IDE) solid-state disk with 256 Mbytes of memory. This mass storage device incorporates a small amount of bit error correction. However, only telemetry and experimental data will be stored on this device. Over long periods of time bit errors will occur; however, at any time the C&DH can choose to reformat this mass storage unit thereby clearing bit errors. This unit will be repackaged so as to fit within the C&DH housing as a PC/104 stackable board.

The A/D and I/O unit is a COTS PC/104 analog I/O module. The C&DH is responsible for collecting various analog signals describing temperatures of boards and parts within the C&DH and signal demodulation strength. This unit also provides digital output which is used to control the local oscillator of the RF system, the GMSK modem, and the CERTO and Langmuir probe.

The C&DH power supply provides all of the power conditioning (3.3V, 5.0V, and 12.0V DC) for the electronics within the housing, including the RF components. The RFS components within the C&DH are isolated from the other electronics for improved electromagnetic compatibility (EMC).

Linux, a POSIX-compliant operating system, was chosen as the operating system for the C&DH for several reasons. First, it is open-source software which is robust and highly configurable. In addition it provides a multi-tasking and Unix-like environment for software development with which the Space Systems Academic Group has extensive experience. The software development tools are plentiful, free (no cost), and powerful.

The C&DH ROM implements a simple BIOS to initialize the 386 microprocessor and peripheral hardware to a known state. The BIOS will then load a compressed version of the Linux kernel. Decompression and startup of the kernel is handled by the kernel itself. At the comple-

tion of the kernel startup the system will load application tasks which are also compressed on the ROM. A release of the Linux 2.4 kernel will be used. Recent developments for the NPSAT1 C&DH kernel are using 2.4.14 and 2.4.19 with the preemptive kernel patch.

Electrical Power Subsystem (EPS)

The electrical power subsystem (EPS) consists of triple-junction solar cells for energy conversion, a lithium-ion (Li-ion) battery for energy storage, and the EPS control electronics which is composed of a processor board with all the digital logic and an analog/switching board for power switching and telemetry gathering. The solar cells are from Spectrolab and are part of a flight demonstration which includes the solar cell measurement system (SMS) experiment. The minimum efficiency of these

solar cells is 24%. The decision was made early in the program to use body-mounted solar arrays, (rather than deployable arrays), to reduce the risk of both inadvertent deployment and failure to deploy or partially deploy. Each cylinder side is used for solar cells. The zenith-facing plate is not used because of the antenna and its respective ground plane. Power budget calculations were performed using a nominal nadir-pointing attitude with a beta angle (angle between the orbit plane and the sun vector) of 0°. For the 35.4° inclination orbit, the beta angle is between ±20° roughly 60% of the time, with a maximum at about 60°. In order to save on power, all experiments are duty-cycled and powered off when not in operation. The power budget uses average energy available per orbit rather than instantaneous power to arrive at scenarios of experiment operation. Table 1 shows the power budget for the nominal case where the spacecraft is nadir-pointing and duty cycles are as shown.

Table 1. Estimated NPSAT1 Power Budget.

Subsystem / Component	Duty Cycle (%)	Avg. Power (W)	Avg. Energy/Orbit (W-hr)
EPS Processor Board	50	.75	1.20
Switch Board A/D	50	.03	.05
Switch Board DAC	50	.03	.05
Switches	100	.50	.80
ACS Torque Rods	50	.02	.02
Processor Board	50	.75	1.2
Magnetometer	10	.14	.22
MEMS	1	.02	.04
C&DH 386 Core	50	.80	1.28
EDAC RAM	25	1.02	1.63
SCC	100	.08	0.13
UART	100	.23	0.37
FPGA	100	.25	0.40
Solid State Disk	50	.15	0.24
A/D	100	2.05	3.27
RFS TX/RX	2	.30	.48
LO (& modem)	3	.09	.14
SMS (only operates in sunlight)			
Processor Board	5	.12	.12
Switch Board A/D	5	.01	.01
Switch Board DAC	5	.005	.005
CERTO Standby	12.5	.43	.69
150/400 MHz mode	20	1.53	2.43
1067 MHz mode	6.6	.34	.54
Langmuir probe	26.5	.42	.68
Configurable Processor Exp.	25	1.00	1.60
VISIM (only operates in sunlight)	8.5	.68	.68
Total Average Energy per Orbit			18.3
Solar Panel Energy (75% eff.)			21.2
Margin (W-hr)			3.0

The EPS electronics are built around a rad-hard UTMC80C196KD micro-controller on the digital board. The digital board also hosts a real-time clock, rad-hard RAM, the watchdog timer for the C&DH, a serial port to interface with the C&DH, and 8 kilobytes of ferroelectric (FERRO) RAM memory. The analog/switching board hosts all the power distribution to the other subsystems to provide a spacecraft power bus of 24V to 40V. Each subsystem is responsible for regulating the power from the bus for its own specific requirements. The analog/switching board is also responsible for taking measurements of such things as battery voltages and temperatures via 32 analog channels which are multiplexed in to a dual, 12-bit analog-to-digital (A/D) converter. Figure 6 shows the block diagram of the EPS electronics.

NPS is currently investigating COTS lithium-ion (Li-ion) polymer batteries for space applications. Initially, it was thought that the Li-ion polymer batteries would be used as the main energy storage device for NPSAT1. However, due to concerns of shelf life, or ‘calendar life’ of the batteries, manufacturing inconsistencies, and the rapid pace of commercial Li-ion polymer battery technology, the current baseline is to fly a Li-ion polymer battery as an experiment to mitigate risk, and use a Li-ion battery (non-polymer) as the main spacecraft battery.

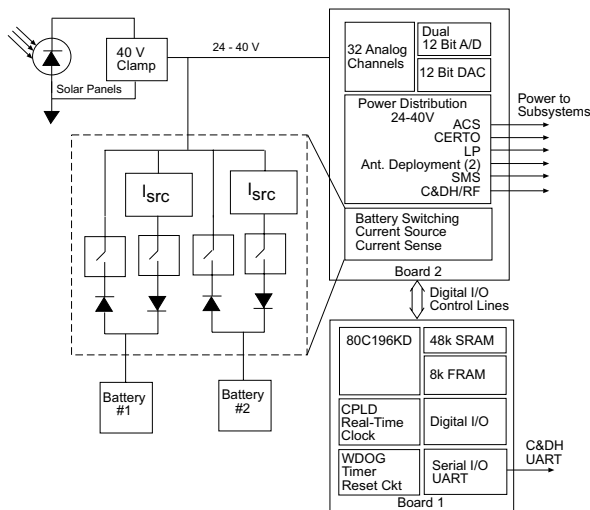

Figure 6. EPS Block Diagram.

Attitude Control Subsystem (ACS)

The NPSAT1 attitude control subsystem (ACS) consists of three magnetic torque rods for actuators, a three-axis magnetometer as the sensor, and the ACS controller. The ACS design provides a novel, very low-cost solution for coarse, three-axis attitude control. A detailed discussion of the ACS control algorithm design and simulation is given by Leonard⁶. In this paper, the hardware design is

presented which will be used to implement the control algorithm. In very brief terms, the ACS controller uses onboard orbit information to obtain the spacecraft’s location and performs a table lookup to obtain the values for the local magnetic field vector at that latitude, longitude, and altitude. Magnetometer measurements are compared to the lookup value and the control algorithm attempts to null the error between the two. Although the magnetic field (B-field) vector gives only one reference vector, because the spacecraft is orbiting the Earth and the ACS is continually ‘chasing’ the B-field vector, three-axis stabilization can be achieved. Simulation results show that 2° of pointing can be achieved.

The ACS electronics is almost identical to the EPS controller. A processor board with a rad-hard UTMC80C196KD and rad-hard RAM will be used to implement the control algorithm. An analog/switching board is used to drive the torque rods, and take measurements from the magnetometer, MEMS rate sensor, and temperature sensors. The analog/switching board also provides the electrical power for the MEMS rate sensor and magnetometer. Spacecraft navigation information (latitude and longitude) is required in order to perform the table lookup of the local B-field vector. Where the actual location determination will be performed is yet to be decided. The issues relate to processing and memory requirements which ultimately are limited by available power. Another option is to perform orbit propagation on the ground and send up the required information to the spacecraft in some form of compressed format. Figure 7 shows the block diagram of the ACS electronics.

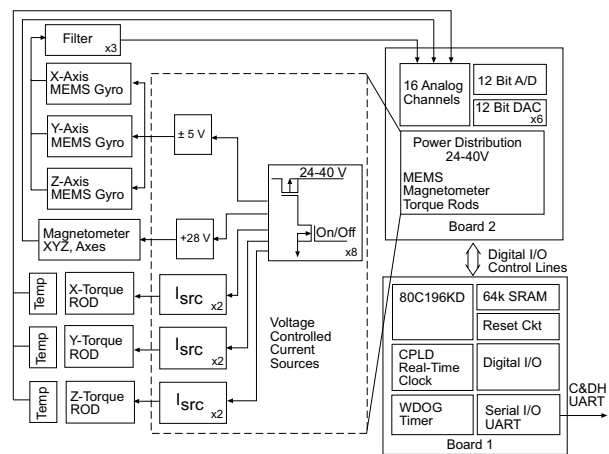

Figure 7. ACS Block Diagram.

Radio Frequency Subsystem (RFS)

The NPSAT1 radio frequency subsystem (RFS) is a full-duplex system with 100 kilobits per second transmission rate on both the uplink and downlink channels. As stated

earlier, the antenna system will be able to view in either the nadir-pointing direction or the zenith-pointing direction of the spacecraft in the event the spacecraft loses pointing capability. In the nominal case where the spacecraft is properly nadir-pointing, only the nadir-pointing antennas will be used for communications. Gaussian, minimum-shift keying (GMSK) will be used for modulation. An off-the-shelf solution was found for the modem. The frequency conversion electronics between the intermediate frequency (IF) and the transmit/receive frequencies is planned to be built in-house.

NPSAT1 will operate at 1767.565 MHz in the forward, or uplink channel, with a return link at 2207.3 MHz. The RFS uses a single-conversion to baseband with 70 MHz as the IF. A maximum bit-error-rate of 1×10^{-5} was set as a requirement for the system. The link budget shows positive margins of 13.6 dB for the forward link and 9.8 dB on the return link. Figure 8 shows the RFS block diagram for the spacecraft. The modem is physically located in the same housing as the C&DH. This is done because of the intimate connection between the modem and processor board. The modem is manufactured by SpaceQuest, Ltd., of Fairfax, Virginia. The FM Exciter, responsible for converting the GMSK baseband signal to the IF 70 MHz signal, and the FM Detector, which converts from the IF receive signal to the analog baseband, are of NPS design.

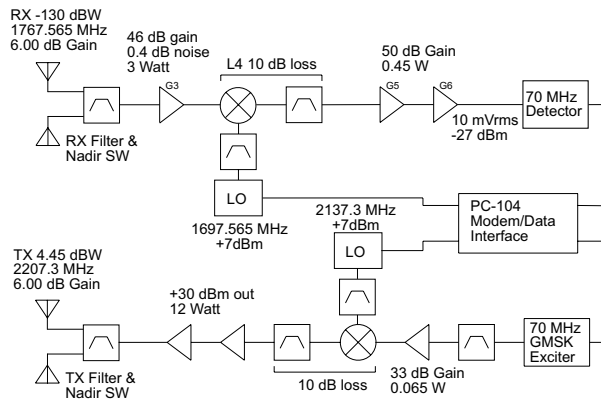

Figure 8. Spacecraft RFS Block Diagram.

Mechanical

The mechanical structure is based on heritage equipment from a canceled Navy, small satellite program; and is made entirely of aluminum. The load-bearing structure is very robust and consists mainly of a twelve-sided cylinder and three equipment plates. As a secondary payload, a robust structure is mandatory since the launch carrier is not known at the time of initial design. Further-

more, launch opportunities for secondary payloads are not guaranteed if the primary payload is canceled, grows beyond its initial margin, or is delayed due to funding or technical problems. Following manifesting on the MLV-05 mission, no attempt was made to optimize the NPSAT1 structure for weight savings. Although the design limit loads for the MLV-05 secondary payloads were not defined, a conservative estimate of 12 g static loads were applied with a factor of safety of 1.25 in all directions in a finite element analysis (FEA), i.e., 15 g in X, Y, and Z. The FEA results were combined by simply adding the results for each axis, X, Y, and Z, and provided margins of safety greater than 5.

An upper section was added to the load-bearing structure to accommodate additional solar panels, and is also used to mount an end plate, the zenith-pointing antennas, and the sun sensor modules required by the SMS. This upper section also allows for approximately two inches of area about the cylinder sides for the retention device for the deployable booms, and for handling points. The actual requirements for handling of the structure are undefined, however, because the integration process for this new ESPA capability have not been defined. Flexibility becomes to rule in order to accommodate integration either horizontally or vertically, as well as allowing for correct angular orientation about the separation system, i.e., 'clocking.'

NPSAT1 mechanisms include the microswitches which are components included with the separation system, the deployment mechanism of the deployable booms, and the retention mechanism which holds the booms in the stowed position. The deployment mechanism of the CERTO antenna and Langmuir probe boom are heritage components that have flown for approximately 20 years. CERTO, and its deployment mechanism, have flown recently on the P91-1 ARGOS satellite and will launch aboard the C/NOFS satellite. The deployment mechanism is composed of a hinge at the base for rotation to the stowed position. The hinge is attached to a short stanchion which is free to slide inside the base of the boom. The stanchion is connected to the boom via a spring which, when the boom is released, pulls the boom and joins it with the hinged base via a conical mate, which aligns it normal to the base. The booms will deploy with alignment along the +Y axis and -Y axis of the spacecraft coordinate system, pointing in the plus and minus orbit normal directions.

The retention mechanism for the deployable booms is the least mature aspect of the spacecraft. Conceptually, a pin-puller device will be used to hold a lanyard which holds the boom near the end, and also provides a pre-load on the boom. The boom will have a restraint point such that

it will look much like a simply supported beam with a point-load where the restraint is located. Issues to be considered with a deployment mechanism of this type fall under the topics of inadvertent release, motion-of-travel from beginning to end, electrical malfunction, and damage to the nearby equipment, such as the solar cells, due to release event.

Preliminary thermal analyses were performed on the NPSAT1 spacecraft. However, because of the changes in the configuration and power budget (with the addition of the triple-junction solar cells), a detailed thermal model remains a near-term goal. Initial results of a simple thermal analysis showed that the solar cell temperatures, which are obviously on the spacecraft exterior, range from -22°C to $+30^{\circ}\text{C}$. This temperature range is sufficient for the industrial-grade electronics components used in NPSAT1; and because the electronics are in the interior of the spacecraft, the extreme temperatures should be bounded well within the solar panel temperature range. The critical components for the thermal design are the batteries. The lithium-ion polymer batteries need to be operated within the range of 0°C and $+45^{\circ}\text{C}$, with optimal operating temperature at 10°C . The battery design for the lithium-ion polymer batteries accommodates a heater strip, and thermal isolation is planned for the batteries to lower the contact conductance between the battery box and the equipment plate. The detailed thermal model will provide estimates of the duty cycling of the heaters to maintain optimal temperatures.

NPSAT1 Experiments

CERTO and Langmuir Probe

The CERTO experiment and Langmuir probe are two Naval Research Laboratory (NRL) payloads configured to operate within NPSAT1. The CERTO experiment is a radio beacon that transmits at three frequencies 150, 400 and 1067 MHz. The space-based beacon, in conjunction with a network of ground receivers, will be used to measure the integrated electron density of the ionosphere in the plane of observation. CERTO will also be used to develop and test tomographic algorithms for reconstruction of ionospheric irregularities; to provide a database for global models of the ionosphere; to characterize the ionosphere for geolocation; and to perform scintillation studies of the ionosphere. Radio beacons provide measurements of the scintillation environment that degrades military system performance. The electron density characterization is used to correct for ionospheric refraction that limits space-based geolocation of ground transmitters. The CERTO beacon may be used in operational systems for both of these uses.

NPSAT1 will operate the CERTO and Langmuir Probe in four modes. The first mode is for checkout of the electronics, beacon antenna, and the probe data collection. The second mode is the mode used in normal day-to-day operations where the objective is to collect total-electron-content and scintillation data from a chain of ground receivers in the USA, South America, and India. The 150 and 400 MHz frequencies will be on continuously while over a ground chain. In addition the 1067 MHz frequency will also be used during local times between 18:00 and 24:00 when within a Latitude of $\pm 15^{\circ}$. During normal operations, the Langmuir probe will be enabled collecting four separate 12-bit A/D channels at samples rates between 1 and 1000 samples per second. Two other modes are envisioned which will occur several time a year for a one to two day period. These special modes are called CERTO/CITRIS Tandem modes. Since STPSAT, another spacecraft on the MLV-05 mission, will be placed into a similar orbit with NPSAT1 and is hosting CITRIS, the space-based receiver counterpart to CERTO, conjunctions with NPSAT1 will occur. The objective will be to perform tandem operation for Ionospheric monitoring of small scale irregularities. One of the Tandem modes will operate for about eight minutes collecting Langmuir Probe data. The other mode will operate for up to two days but not operate the Langmuir probe.

Configurable Processor Experiment (CPE)

The Configurable Processor Experiment (CPE) is a NPS module. This experiment consists as a single electronic circuit board and housed within the C&DH. It interfaces with the C&DH motherboard via the PC/104 bus for power and digital control and data.

The CPE is a low-power design. The design is centered around a field-programmable gate array (FPGA) which can be programmed for virtually any type of compute engine for a specific application. The first scenario is to have the board act as a triple-modular, redundant (TMR) computer, where within the FPGA, three core processors run in-step. Single event effects (SEE) within the processing are detected and corrected through voting logic without the need to reboot the processor. Because NPSAT1's orbit is in a relatively radiation-benign orbit, CPE operations for the TMR configuration will focus on recording SEEs near the South Atlantic Anomaly.

The configurable aspect allows in-flight upgrades to the processor configuration. The second scenario being considered is to implement a hardware image compression engine. This configuration would be capable of producing JPEG representations of the VISIM data.

Solar Cell Measurement System (SMS)

As mentioned earlier, the solar cells are from Spectrolab and are part of a flight demonstration. Twenty-four test cells will be placed around the body of the spacecraft, two per each twelve sides, in order to collect data about the performance of the solar cells. The SMS will perform current-voltage (IV) curve traces twice per orbit for each illuminated test cell. Fifty sample points per IV curve will be collected for each test cell. The data collection concentrates on three points: the open circuit voltage, the short circuit current, and the maximum power point. In addition temperatures for each panel containing test cells are collected. NPSAT1 has six sun sensor modules to provide 360° field-of-view in azimuth and $\pm 64^\circ$ in elevation. The modules are the model 13-515 double triangle sun sensor module manufactured by BF Goodrich.

The SMS digital electronics are very similar to the ACS and EPS. A processor board with a rad-hard UTMC80C196KD and rad-hard RAM will be used to implement the control algorithm. A control algorithm is permanently stored in ROM; parameters regarding the behavior of the control can be modified while in orbit. In addition, a new control algorithm can be uploaded while in orbit. A solar cell measurement circuit interfaces be-

tween the test cells and the microprocessor. This measurement circuit allows individual control of each test cell to perform the IV curve testing and provide data to the microprocessor. Figure 9 depicts a block diagram of the SMS.

Visible Wavelength Imager (VISIM)

The Visible Wavelength Imager (VISIM) is a COTS digital camera operated by a COTS single board computer. The CCD controller is a PC/104 board. The single-board computer is a 486 running at 66 MHz supporting the PC/104 bus. The electronics will be modified slightly for reliability. The CCD and controller consume 2.5 W and the single-board computer another 2.5 W. This system will normally be powered off and turned on only for a small period of time when passing over an area of interest to take images and process the data. A block diagram of this system is shown in Figure 10.

The CCD is an Electrim EDC-1000E. This CCD provides 8-bit color (each) RGB Bayer pattern, a square pixel of 7.4 microns, and a resolution of 652 horizontal and 494 vertical. At an exposure time of 10 msec, given NPSAT1's orbit of 560 km and a focal length of 14 mm, images of the Earth will have a pixel blur of about 0.25

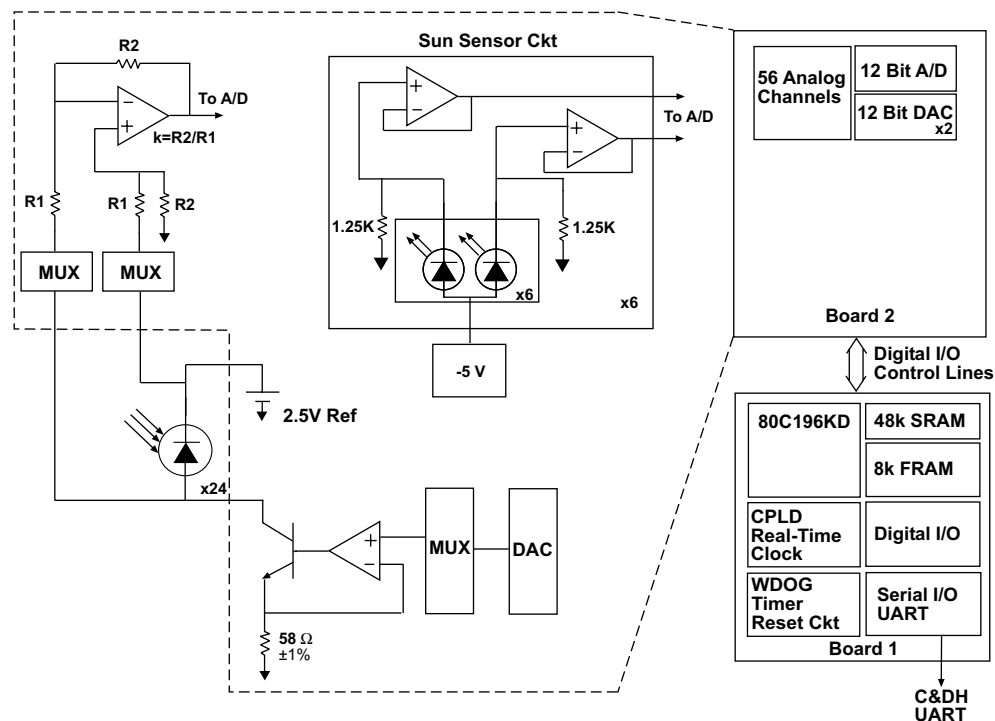

Figure 9. SMS Block Diagram

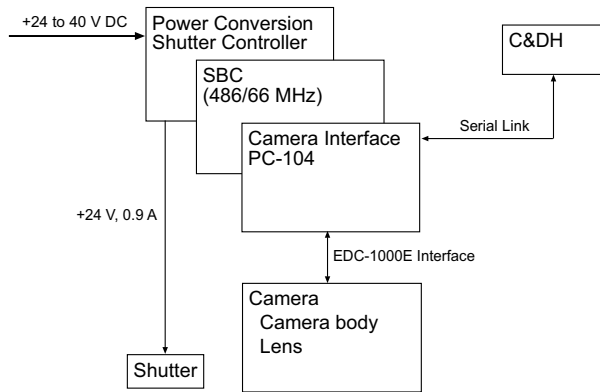

Figure 10. VISIM Block Diagram

pixel and a field-of-view of 20° horizontally and 30° vertically or approximately 200 km by 150 km when pointing exactly nadir. Without increasing pixel blur, exposures times approaching 1 msec may be possible and a longer focal length lens may yield field-of-views of about of 6° horizontally and 9° vertically or approximately 60 km by 40 km.

The computer runs a version of 2.4 of the Linux operating system. Currently drivers for version 2.14 are implemented and operating the CCD controller. This computer system accepts commands from the C&DH regarding the number of images to acquire, the time between successive images, and various parameters regarding the CCD. The raw data is lossless-compressed using bzip2. A lossy representation using JPEG at very high compression is also generated as a preview of the image; the idea being that these previews can be downloaded to the NPS ground station where it will be decided whether or not the raw data should also be downloaded in order to save communication bandwidth. The VISIM computer sends the lossless and lossy versions of the raw data back to the C&DH for storage and for future download to the NPS ground station. After the download of data the VISIM is powered off.

Ground Segment

The NPSAT1 ground station is located at the Naval Postgraduate School in Monterey, California. This station, based off of the PANSAT ground station design, will autonomously command the spacecraft and perform data collection. A choice to use COTS hardware and a foundation of Open Source software, was decided in order to reduce costs and development time.

Hardware Description

The NPSAT1 ground station radio frequency subsystem consists of many of the same elements as found within the spacecraft. The same SGLS frequencies are used, but reversed for uplink/downlink, as the spacecraft. The antenna is a 3.3 m reflecting dish with left or right circular polarization, a single L/S Band feed, and two-axis position control. The ground modem interface, Figure 11, is very similar to its spacecraft counterpart, except for the diplexer at the antenna and reversal of the frequencies for uplink and downlink.

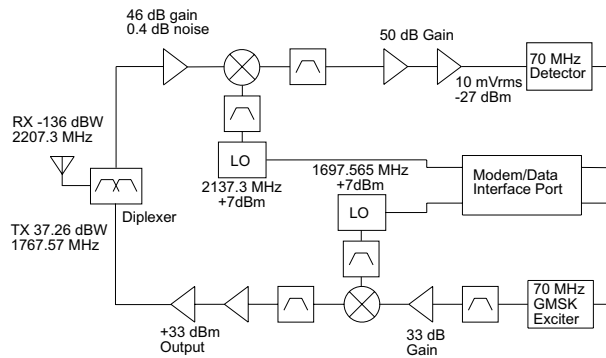

Figure 11. Ground Modem Interface

A single COTS PC compatible computer controls the entire system. This includes interfaces to the antenna tracking, the ground modem interface, and the transmit and receive local oscillators which are programmed for Doppler shift. This PC tracks the spacecraft using a modified version of SatTrack, which is open source Unix-based software. Telemetry and experimental data are collected on and archived from this computer. This ground station computer is attached to a LAN so as to simplify the distribution of spacecraft data and the scheduling of spacecraft activities. Spacecraft ephemeris is updated daily by the ground station.

Ground Site Operations

The Naval Postgraduate School, located at a latitude of 36.6° N, will have approximately five passes per day with about six minutes for each pass. This averages to about 34 minutes a day of communication (10° above the horizon). At 100 kbit/sec the ground station will be able to download approximately 20 Mbytes of spacecraft telemetry and experimental data every day.

Daily operations will be broken into several passes, about 1-1/2 hours apart. A typical day will start with the first pass uploading orbit ephemeris and spacecraft time. Thereafter the JPEG previews of the VISIM pictures will be downloaded. As time allows, the downloading of stored

telemetry and experimental data will continue. Immediately after this pass, spacecraft operators (and/or software) will select VISIM pictures in which the raw data should be downloaded during the next pass. In addition, abnormal conditions within the spacecraft as detected by analyzing the telemetry will cause the ground station to notify NPS personnel via email.

The second and later passes will continue as follows. The ground station will continue downloading telemetry, VISIM raw data (as selected from the previews), and data from the other experiments. Upon completion of the downloading, as time and available power on the spacecraft allow, uploading of various information to NPSAT1 begins. This includes new VISIM targets; new parameters for CERTO/Langmuir probe, the ACS, EPS, SMS, and VISIM; new controller software for the ACS, EPS, SMS, and VISIM; and new or modified applications for the C&DH.

Experimental data from the CERTO/Langmuir probe and the solar cell experiments will be immediately available to those requiring the data via the Internet. Other select data regarding the general status of the spacecraft will also be published immediately on the Internet via a World Wide Web (WWW) server. As part of an educational outreach, NPS will make the VISIM pictures available via the WWW. In addition to viewing VISIM pictures, users will be able to request sites desired for future image taking.

Conclusions

NPSAT1 offers a novel spacecraft architecture which can be used as a template for the small satellite builder. The innovative design promises a means of software streamlining and enriching the software development process by using widely-available and low-cost tools. The spacecraft will also serve as a platform for science experiments with military relevance, a validation of low-cost technology for space applications, and of course, enhancing the NPS mission of education.

References

- 1 . Design, Construction, and Testing Requirements for One of a Kind Space Equipment, DOD-HDBK-343, Feb. 1986, USAF.
- 2 . D. Sakoda, R. Phelps, J. Horning, D. Rigmaiden, and J. Damerau, "Naval Postgraduate School

PANSAT: Lessons Learned," Proceedings of the AIAA Space 2001 Conference and Exposition, Albuquerque, NM, August 28-30, 2001.

- 3 . D. Sakoda, "Overview of the Naval Postgraduate School Petite Amateur Navy Satellite (PANSAT)," Proceedings of the Thirteenth Annual AIAA/Utah State University Conference on Small Satellites, Paper SSC99-I-5, Logan, Utah, Aug. 1999.
- 4 . Lt. J.S. Goodwin, S. Weis, L. Berenberg, and Dr. P. Wegner, "Evolved Expendable Launch Vehicle Secondary Payload Adapter - A New Delivery System for Small Satellites," Proceedings of the Fifteenth Annual AIAA/Utah State University Conference on Small Satellites, Paper SSC01-X-6, Logan, Utah, Aug. 2001.
- 5 . C. R. Oechsel, Implementation of Error Detection and Correction (EDAC) in the Static Random Access Memory (SRAM) Aboard Petite Amateur Navy Satellite (PANSAT), Master of Science in Electrical Engineering Thesis, Naval Postgraduate School, Monterey, California, March 1995.
- 6 . B. Leonard, "NPSAT1 Magnetic Attitude Control System," (to be published) Proceedings of the Sixteenth Annual AIAA/Utah State University Conference on Small Satellites, Paper SSC02-V-7, Logan, Utah, Aug. 2002.