



**Calhoun: The NPS Institutional Archive**  
**DSpace Repository**

---

NPS Scholarship

Theses

---

1954-05

An investigation of the effect of minute  
motion path variations upon operator performance

Clark, Robert Ora

Purdue University

---

<https://hdl.handle.net/10945/14307>

---

*Downloaded from NPS Archive: Calhoun*



Calhoun is the Naval Postgraduate School's public access digital repository for research materials and institutional publications created by the NPS community. Calhoun is named for Professor of Mathematics Guy K. Calhoun, NPS's first appointed -- and published -- scholarly author.

**Dudley Knox Library / Naval Postgraduate School**  
**411 Dyer Road / 1 University Circle**  
**Monterey, California USA 93943**

<http://www.nps.edu/library>

Robert Ora Clark

---

AN INVESTIGATION OF THE EFFECT  
OF MINUTE MOTION PATH VARIATIONS  
UPON OPERATOR PERFORMANCE.

THESIS  
C483

Library  
University of California School  
Northridge, California





AN INVESTIGATION OF THE EFFECT OF  
MINUTE MOTION PATH VARIATIONS  
UPON OPERATOR PERFORMANCE

A Thesis

Submitted to the Faculty

of

Purdue University

by

Robert Ora Clark

W

In Partial Fulfillment of the

Requirements for the Degree

of

Master of Science

in

Industrial Engineering

May, 1954

Thesis  
C 483

#### ACKNOWLEDGMENTS

The author wishes to express his sincere appreciation to Hewitt H. Young of Purdue University for his guidance and many helpful suggestions. The author is indebted to Barbara O. Clark for her constant encouragement and to the willing subjects who gave of their time in participating in the experiments.



## TABLE OF CONTENTS

	Page
ABSTRACT .....	v
INTRODUCTION .....	1
PROCEDURE .....	6
Objective .....	6
Method of Measurement .....	6
Apparatus .....	7
Test Procedure .....	21
ANALYSIS OF RESULTS .....	28
CONCLUSIONS AND RECOMMENDATIONS .....	32
APPENDIX A. DATA FROM INDIVIDUAL SUBJECTS .....	35
APPENDIX B. CALCULATIONS .....	48
BIBLIOGRAPHY .....	64

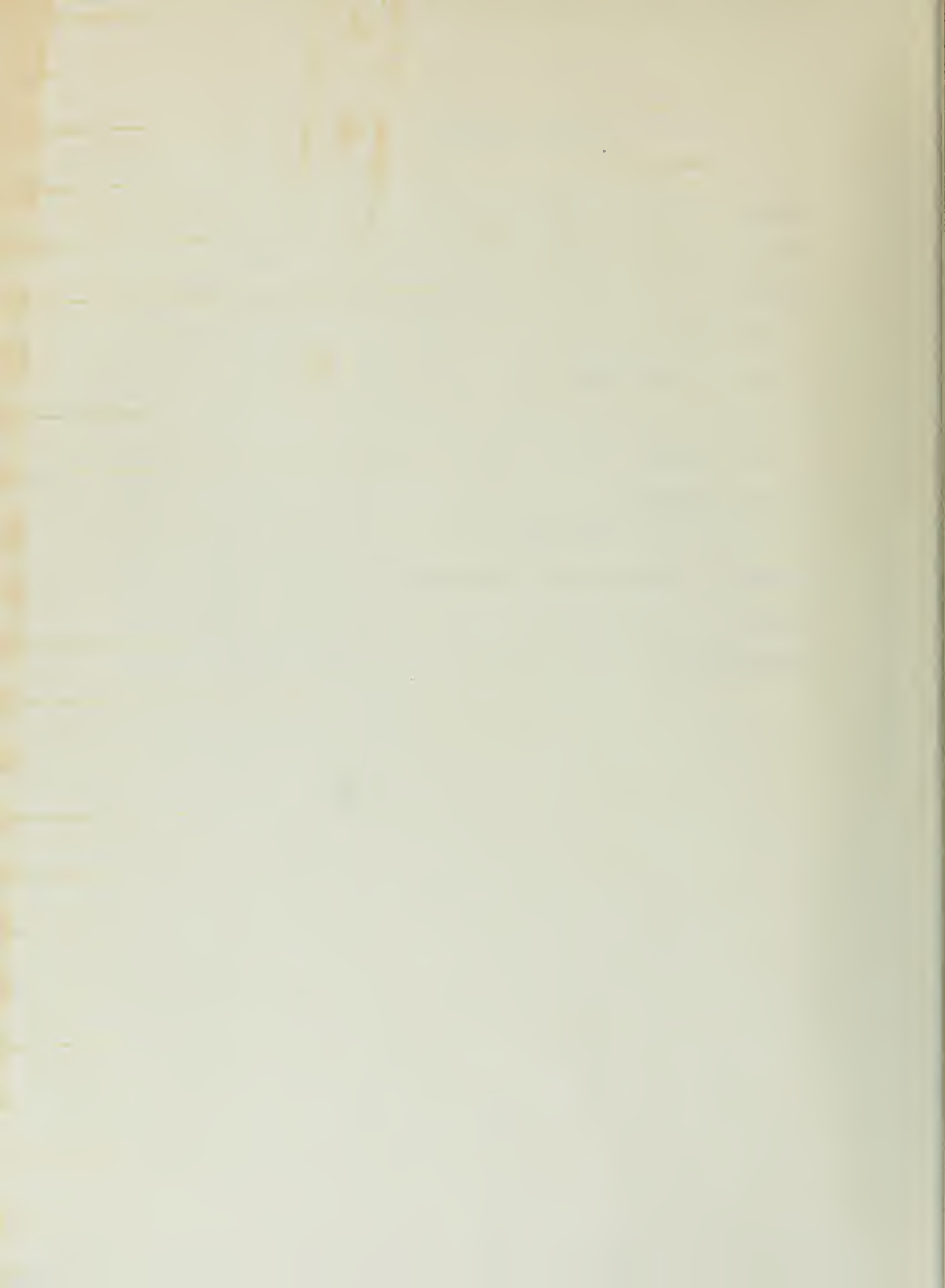

## TABLES

Table	Page
1. Data for Operator 1 .....	36
2. Data for Operator 2 .....	37
3. Data for Operator 3 .....	38
4. Data for Operator 4 .....	39
5. Data for Operator 5 .....	40
6. Data for Operator 6 .....	41
7. Data for Operator 7 .....	42
8. Data for Operator 8 .....	43
9. Data for Operator 9 .....	44
10. Data for Operator 10 .....	45
11. Data for Operator 11 .....	46
12. Data for Operator 12 .....	47
13. Correction of Photographic Measurements .....	49
14. Computation of Analysis of Variance .....	50
15. Intermediate Data of Analysis of Variance .....	54
16. Comparison of F Values .....	56
17. Computation of Components of Variation .....	57
18. Components of Variation .....	59
19. Computation of Multiple Comparison of Means .....	60
20. Multiple Comparison of Means Intermediate Data .....	62
21. Results of Multiple Comparison of Means .....	63

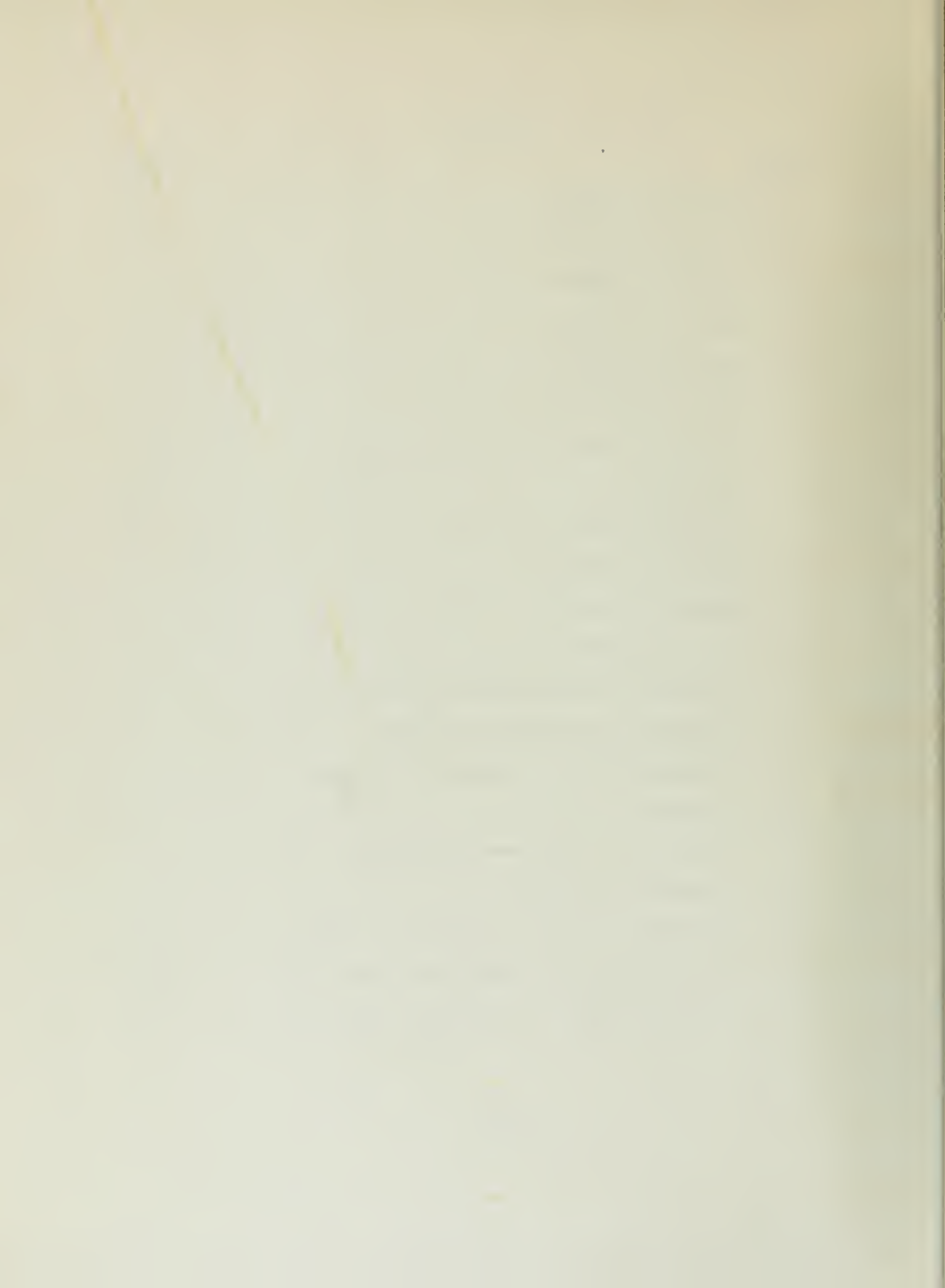

## FIGURES

Figure		Page
1.	Work Station Surface .....	8
2.	Eastman Ciné Special Camera Mounted Above Work Station .....	10
3.	Victor Camera Mounted to Right of Work Station .....	11
4.	Horizontal Cross-Sectioned Background .....	12
5.	Vertical Cross-Sectioned Background .....	13
6.	Kymograph .....	15
7.	Operator's Thumb Device for Completing Timing Circuits .....	17
8.	Reproduction of a Record Made by Solenoid- Operated Pens on the Kymograph Tape .....	19
9.	Wiring Diagram of Electrical Devices .....	22
10.	Instructions for Operators .....	23

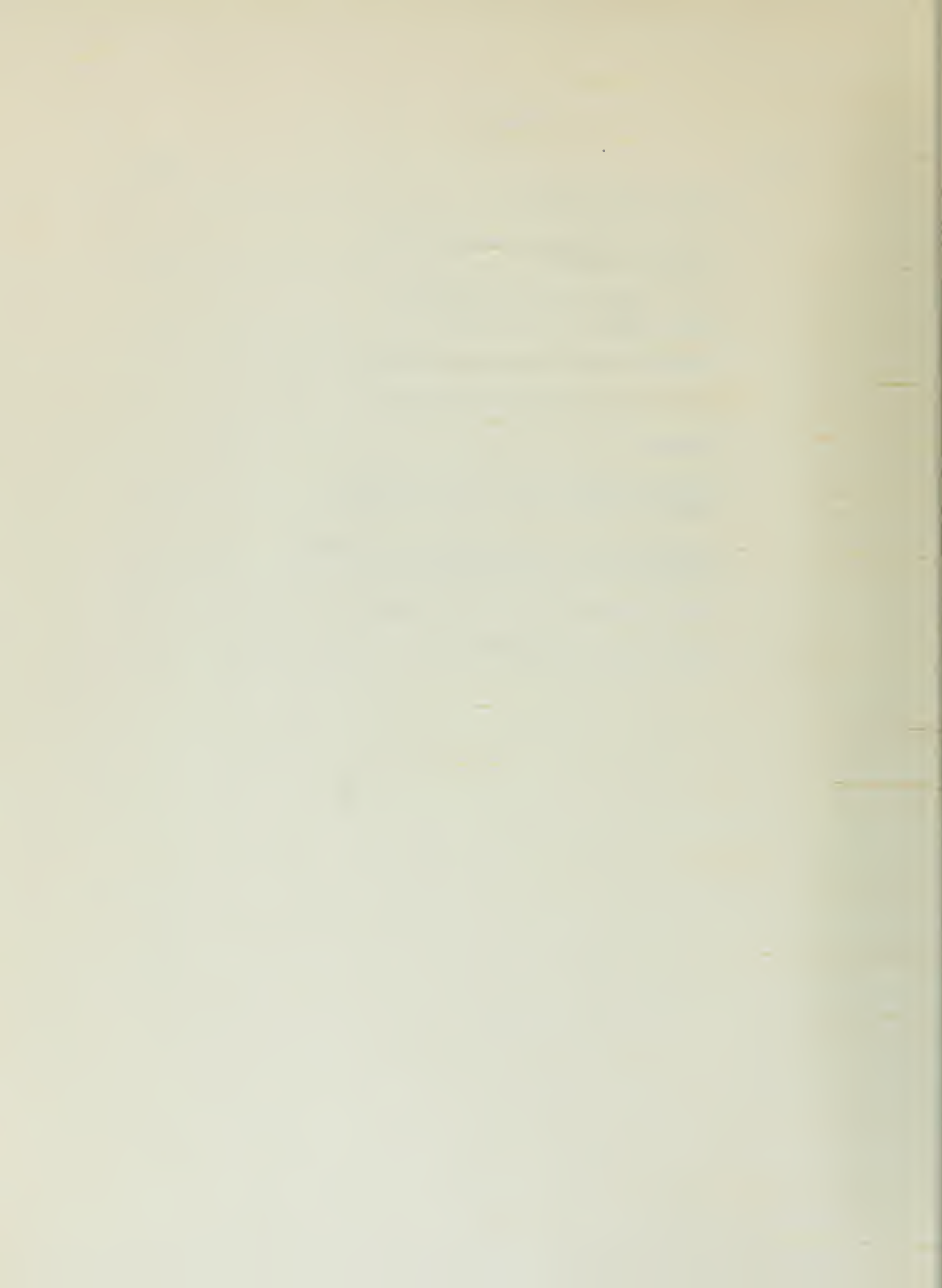

## ABSTRACT

The technique of time study, originated by Taylor, and the technique of motion study, developed by the Gilbreths, are used together in the present day study of production jobs. As a result of this job study the analyst must decide upon a standard rate of activity for each element of the operation. This decision, being based in part on the analyst's observation of the operator, is complicated by several factors, one of them being the variations in the motion paths of the operators. Also, researchers have found some relationships between the motion path variations of operators and their job performance.

The object of this investigation was to compare minute variations in motion paths, for standardized therblig activity, with the times required to complete these motions as a measure of operator performance.

A task which involved a sequence of therbligs required to traverse a triangular work area containing three stations was selected for investigation. Four transport empty and two transport loaded therbligs were included in the task. The task was performed by twelve male subjects at three selected rates each. These rates consisted of maximum, about 75% of maximum, and about 50% of maximum.

The criterion selected for the minute motion path variations was the distance of the point of maximum deviation on the motion path as measured from a reference line. Films taken with motion picture cameras mutually at right angles were the bases for this measurement. The time required for one work cycle was selected to be the criterion of operator performance.



The statistical analyses of the results showed that a significant difference exists in the motion paths used at standardized performance levels. This would indicate that pace rating through observation of speed of movement may be erroneous since the performance time required to make a given movement may vary due to minute variations in motion path even though the speed of movement remains constant.

The experimental results indicated that the motion paths of the operators studied did not follow any definite pattern as to the amount or the type of their changes as performance rate changed.

The operators were found to be the largest source of motion path variations.

The motion paths comprised of side-to-side hand movements were found to be more consistent for the operators studied than those paths which were comprised of to-and-from movements.

A recommendation was made that further study of motion path variations, such as velocity, be made to evaluate the magnitude of the effect of these variations upon performance time.



AN INVESTIGATION OF THE EFFECT OF MINUTE MOTION  
PATH VARIATIONS UPON OPERATOR PERFORMANCE

INTRODUCTION

In about 1883 Frederic Winslow Taylor started his scientific analysis and improvement of human methods of work. He later made some of the first important contributions to scientific analysis and improvement of human methods of work. In general, Taylor<sup>1</sup> used motion study and determined the correct method before setting a rate, but his objective was to find out the correct time which a given piece of work should take. Taylor has often been called the "father" of time study.

Frank B. Gilbreth, who commenced his industrial work in 1885, became so interested in the study of motion and elimination of waste that, with Mrs. Gilbreth (a trained psychologist), he devoted his entire time to motion study and the related work of fatigue elimination. Gilbreth<sup>2</sup> used time in analyzing performance, but his fundamental objective was the finding of the correct method for an operation. In their work the Gilbreths made use of motion pictures in recording the motion of various operations so that they could be studied in detail at any time. To get a record of the time required for these motions, Gilbreth developed a microchronometer<sup>3</sup>, a fast moving clock which recorded time in fractions of 1/2000 of a minute.

---

<sup>1</sup>Sampter, H.C., Motion Study, Pitman Publishing Company, New York, 1941, p. 1.

<sup>2</sup>Ibid., p. 4.

<sup>3</sup>Gilbreth, F.B. and L.M., Applied Motion Study, Sturgis & Walton Company, New York, 1919, pp. 80-81.



One of these instruments, together with an ordinary clock, was placed in the background to be photographed. The background and the work table were cross-sectioned in squares to facilitate measurement of motions. In this way a stereoscopic motion picture camera<sup>4</sup> recorded simultaneously the actions of the operator and the time of the two clocks. The film provided a permanent record of work conditions, of movements made, and of times taken. It could be studied at any desired time and speed, permitting the photographed activity to be slowed down for ease of analysis. The path, length, direction, and speed of any motion could thus be studied at leisure, and any regrouping or new subdivision could be made without re-running the study.

The present day study of production jobs may be classified by the three techniques of job study as outlined by Alford and Bangs<sup>5</sup>:

Studying of production jobs can be carried on: (1) by simple motion study and measurements with stopwatch in the shop; (2) by micromotion study and measurements with motion picture camera, microchronometer, etc., in the laboratory; or (3) by a compromise between techniques (1) and (2).

As a result of this job study the motion and time study analyst is expected to determine the most practical and economical method of job performance coincident with permitting efficient utilization of the equipment involved. In addition, he is expected to specify the length of time necessary for the various elements of the work cycle. These detail-time items will total to the necessary time to complete

---

<sup>4</sup>Ibid., p. 114.

<sup>5</sup>Alford, L.P., and Bangs, J.R., Production Handbook, Ronald Press Company, New York, 1947, p. 455.



a part, a multiple of parts, or a unit of the product. This time value may be further increased to take care of maintaining the operator's productive activity. The analyst must first, however, make a thorough study of the operator at work.

An operator must go through a variety of motions to complete a work cycle. The members of his body should be moved to conform to the type of motion, its required length, its desired location, and to a speed consistent with good practice for efficiency, economy, and endurance. Holmes<sup>6</sup> has found, however, that the various operators within a single department worked at different rates of speed with varying efficiencies and skill. In addition, he has found that among average operators there is a wide range of variables in the time taken to perform the various movements, or in terms of motion study, to complete the various therbligs.

These time variables are important; for in order to establish an overall time for an operation that will be fair to all operators, a standard rate of activity of each element of the operation must be decided upon by the analyst. The typical time study procedure, as outlined<sup>7</sup> by Mundel, is:

The time study observer first judges (a) job difficulty, in order to form a concept of the appearance of adequate performance for the job (as required by the definition of standard time he is using), and then judges (b) observed pace, against this imagined concept.

---

<sup>6</sup>Holmes, W.G., Applied Time and Motion Study, The Ronald Press Company, New York, 1938, pp. 251-252.

<sup>7</sup>Mundel, M.E., Motion and Time Study, Prentice-Hall, Inc., New York, 1950, pp. 320-321.



Even with the objective rating procedure proposed by Mundel<sup>8</sup>, the analyst must still judge the degree of difference between the pace of the observed job and a predetermined concept of normal pace.

To complicate the observation of the operator as is required by rating, there are such factors as stated by Holmes<sup>9</sup>:

The operator's manual dexterity is the greatest cause of misjudging his productive ability. Anyone is apt to compare the operator's action throughout a work cycle with what his own actions might be and because one has not learned the rhythm cycle and must mentally order each action to be performed he is impressed with the operator's seeming ability ... Many dexterous operators do not produce anywhere near the quantity easily possible for them to accomplish, but their actions are so impressive that the fact is overlooked that their work cycle is merely coordination ... An operation can be made to look harder than it really is by an excess of elbow and shoulder moving. The arm may have to be moved to move the hand a distance of 12 inches. A natural swing of the arm in the shoulder socket will accomplish this, but some operators jerk the elbow, raise or lower it, or do both, or include back bending, or movements peculiar to themselves.

A prominent industrial firm has recently conducted extensive research concerning the determination of a reliable method of evaluating tempo (rate of activity or pace). One of the findings of their research project was that differences in job output were caused primarily by minute variations of operator movement within a standardized method.

---

<sup>8</sup>Ibid., pp. 321-325.

<sup>9</sup>Holmes, W.G., (op. cit.), pp. 202-203 and p. 275.



The Gilbreths<sup>10</sup> found experimental evidence to the effect that fast motions and slow motion of the hands and arms of an operator do not occupy the same paths or orbits. They concluded that these motion paths differed because of the different muscle tensions involved, such tensions being differently affected by the variables of centrifugal force, inertia, momentum, combination of motions and play for position.

Since some of the references previously cited have found relationships between the motion path variations of operators and their job performance, and because such motion variations are a complicating factor in rating, it was decided to investigate the motion paths of several operators performing simple tasks at different rates of activity to see if these paths varied with operator performance.

---

<sup>10</sup>Gilbreth, F.B. and L.M., (op. cit.), p. 86, pp. 109-111, and p. 119.



## PROCEDURE

## Objective

The object of this investigation was to compare minute variations in motion paths, for standardized therblig activity, with the times required to complete these motions as a measure of operator performance.

## Method of Measurement

The minute variations in the work motion paths of each transport therblig were separately measured by determining the shortest distance from the point of maximum deviation on the motion path to a selected reference line. It is realized that this measurement applies directly to only one particular variation in a motion path. Based on the experimental evidence of Smalley<sup>11</sup> that body motions of a type identical to those of this study are similar to the ballistic motions of projectiles and the established fact<sup>12</sup> that such ballistic motion paths are related to their maximum ordinates, however, it was considered that this measurement would serve as an index of the general magnitude of the motion variations of the particular transport therbligs which were studied. The performance of the operator was measured by the total time required per individual therblig and per total cycle.

---

<sup>11</sup>Smalley, H.E., "An Evaluation of Two Methods of Measuring Work Motion Paths", M. S. Thesis, Purdue University, August, 1947.

<sup>12</sup>Rice, J.M., "Theoretical Mechanics", Handbook of Engineering Fundamentals, John Wiley & Sons, Inc., New York, 1949.



### Apparatus

The experiment was designed to enable the motion paths to be photographed in such a manner as to permit three-dimensional measurements and also to enable the time values of the therbligs to be obtained. Since the gross movement therbligs, transport empty and transport loaded, are a part of almost every job, it was decided to construct a simple task which contained several of these therbligs. The experiment was divided into three phases and each phase involved a sequence of therbligs which was required to traverse a path from station 1 to station 1 via stations 2 and 3 and the reverse path back to the starting point. The three phases differed only in the amount of time required for the performance of the task.

All three phases involved (Figure 1) a transport empty of eighteen inches from station 1 directly away from the operator to station 2, a grasp of a two-inch, hollow, metal cube at station 2, a transport loaded of twelve inches with the cube from station 2 to station 3 along a path perpendicular to the path traversed between stations 1 and 2, a positioning of the cube in a metal circular container (four inches in diameter) located at station 3, a release load of the cube in the circular container, and a transport empty of 21.6 inches from station 3 to station 1. From station 1 the direction of the path was reversed.

In order to measure the maximum displacement of the work motion path from the prescribed reference line a three-dimensional method was necessary. Using a modification of the technique outlined by Smalley<sup>13</sup>

---

<sup>13</sup>Smalley, H.E., (op. cit.).



Fig. 1

Work Station Surface





two cameras were mounted at right angles to the work station. The plan-view camera, a 16 mm Eastman Ciné Special (Figure 2) with a 15 mm focal length lens, was mounted a distance of 54 inches directly above and perpendicular to the horizontal surface of the work station. Its lens was centered over the midpoint of the work area. The side-view camera, a 16 mm Victor (Figure 3) with a one inch lens, was mounted to the right of the work area at a distance of  $8\frac{1}{2}$  feet from the center.

Supplementary lighting was provided by one reflector photospot lamp and one photoflood lamp.

Cross-sectioned backgrounds consisting of one inch squares were mounted horizontally on the work surface and vertically to the left of the work surface. These backgrounds were constructed by outlining the squares on cross section paper with India ink. The abscissa and ordinate lines of these backgrounds were numbered at two inch intervals to facilitate the photographic analysis. Diagonal lines, spaced one inch apart, were drawn between station 1 and station 3 to provide reference lines for the motion paths between these stations.

One cross-sectioned background (Figure 4) was mounted horizontally on the work area surface in such a manner that station 1 was centered at the intersection of the 4 inch abscissa and the 0 inch ordinate. Station 2 was centered at the intersection of the 4 inch abscissa and the 18 inch ordinate. Station 3 was centered at the intersection of the 16 inch abscissa and the 18 inch ordinate.

Viewed from the operator's position, the other cross-sectioned background (Figure 5) was mounted to the left of the work area surface



Fig. 2

Eastman Ciné Special Camera  
Mounted Above Work Station





Fig. 3

Victor Camera Mounted to  
Right of Work Station





Fig. 4

Horizontal Cross-Sectioned Background





Fig. 5

Vertical Cross-Sectioned Background

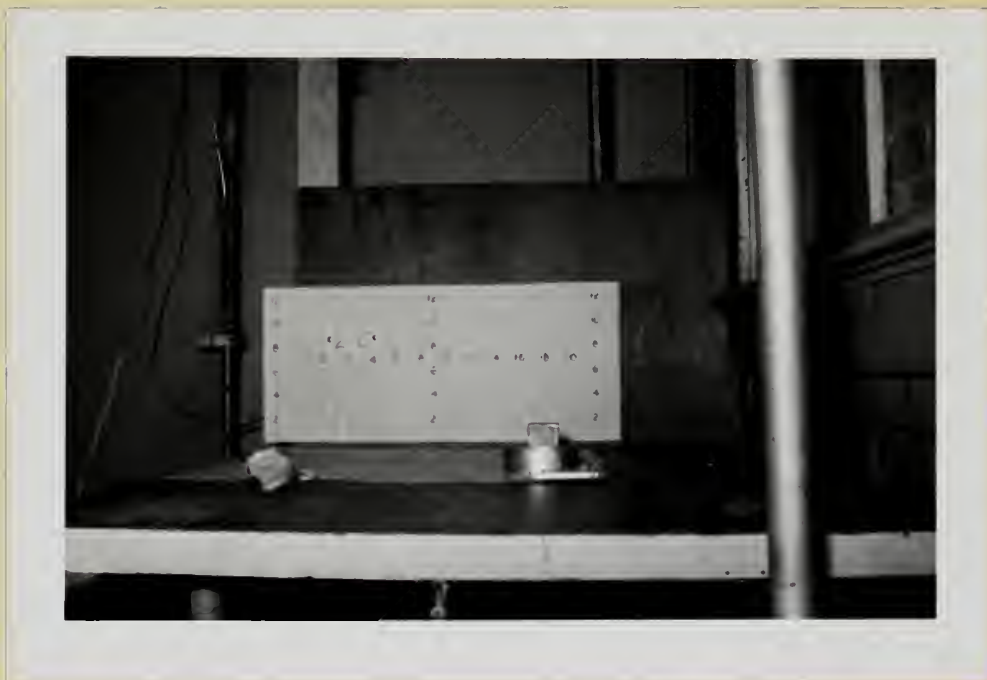



in a vertical position at a distance of 10.75 inches from the 0 inch abscissa of the horizontal background. Its abscissae (vertical) were aligned so as to be the perpendicular continuation of the ordinates of the horizontal background. Its 0 inch ordinate coincided with the horizontal surface of the work station.

Basic reference lines for the measurement of the motion path variations were selected on the horizontal background. They were as follows:

Movement (Station to Station)	Reference Line (inches)
1 to 2	Abscissa 4
2 to 3	Ordinate 17
3 to 1	Diagonal 0
1 to 3	Diagonal 0
3 to 2	Ordinate 17
2 to 1	Abscissa 4

Diagonal 0 was drawn between the intersection points of abscissa 4-ordinate 0 and abscissa 15-ordinate 18. The diagonal 1 was one inch to the left of diagonal 0. Diagonals 2 and 3 were one inch and two inches, respectively, to the right of diagonal 0.

The above-described reference lines were selected on the basis of a preliminary investigation as those lines which would most closely coincide with the horizontal projection of the average motion path.

Due to the unavailability of any cameras with a motor-driven speed of 32 frames per second, a separate timing system was utilized. In order to be able to obtain time values for the individual therbligs and for the overall tasks involved in the three phases of the experiment, a kymograph (Figure 6) was employed<sup>14</sup>. A mesh of fine copper wire

---

<sup>14</sup>Barnes, R.M., and Mundel, M.E., "A Study of Hand Motions Using the Photoelectric Cell and the Kymograph," University of Iowa Studies in Engineering, Bulletin 12.



Fig. 6  
Kymograph

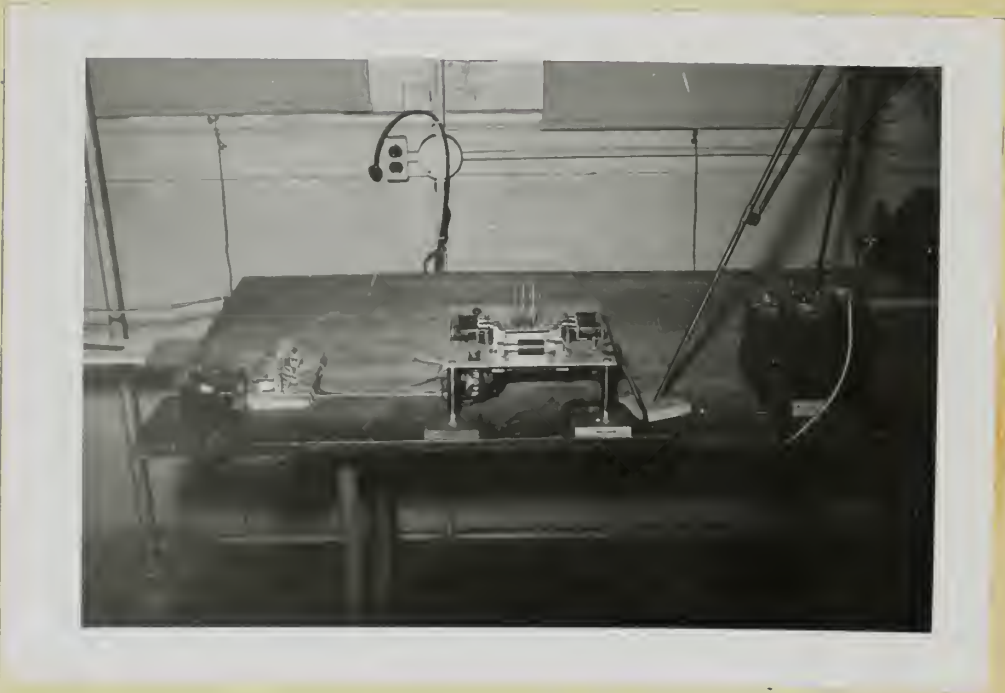



was affixed to the thumb of a right hand glove (Figure 7), and the wire mesh was connected to a multi-volt source. The pens on the kymograph were actuated by solenoids which required a 110 volt, A.C., power source. The use of the six volt position on the multi-volt transformer as the power source for all operator-completed circuits was made possible by the use of relays. The objectionable possibility of an operator receiving an electrical shock was thereby eliminated. Station 1 was a small aluminum angle which was connected to the kymograph through a relay. When the operator's right thumb was in contact with station 1, a circuit was completed, and a solenoid actuated pen 1 on the kymograph.

At station 2, the bottom of the locator for the cube was an aluminum plate which was connected to the kymograph through a relay. When the thumb touched the cube which was resting on the bottom of the locator, a circuit was completed and a solenoid actuated pen 2 on the kymograph. When the cube was removed from the bottom of the locator, the circuit was broken and pen 2 on the kymograph returned to its original position. Also located at station 2 was a photoelectric cell which was in a circuit to pen 3 on the kymograph. To avoid obstructing the work path, the photoelectric cell was mounted beneath the work surface; and the light source, a 75 watt reflector-spot, was mounted vertically above station 2. A three-eighths inch hole in the bottom of the locator permitted the light to fall upon the photoelectric cell when the cube was removed from the locator. This completed a circuit and a solenoid actuated pen 3 on the kymograph.



Fig. 7

Operator's Thumb Device for  
Completing Timing Circuits





At station 3, the device was equipped with an aluminum bottom. When the thumb was in contact with the cube, and the cube was placed in the container, a circuit was completed through a relay and a solenoid actuated pen 4 on the kymograph. Removal of the thumb from the cube broke the circuit and pen 4 returned to its original position. A photoelectric cell was mounted at station 3 in the same manner as described above for station 2. This photoelectric cell was in a circuit which operated pen 5 on the kymograph.

The kymograph drive was powered by a constant speed motor which drew the paper tape under the solenoid-operated pens at an almost constant velocity of 11.1 inches in one-fiftieth of a minute (or one inch in 0.0018 minute). A test was conducted during which fourteen one-fiftieth of a minute pulses of electrical current were led to a kymograph solenoid. The fourteen tapes were measured to the nearest fiftieth of an inch, and the average of 11.1 inches was obtained. The average variation was less than one-tenth of an inch. This result was thought to be satisfactory for the time measurement required by this experiment.

Figure 8 shows a sample reproduction of the record made by the solenoid-operated pens on the kymograph tape. A deflection in line 1, 2, or 4 shows that a circuit has been completed or interrupted by the mesh on the operator's thumb at station 1, 2, or 3, respectively. A deflection in line 3 or 5 shows that a circuit has been completed or interrupted by action of the photoelectric cell at station 2 or 3, respectively. At the start of the tape it will be noted that lines



Fig. 8

Reproduction of a Record Made by Solenoid-Operated Pens on the Kymograph Tape

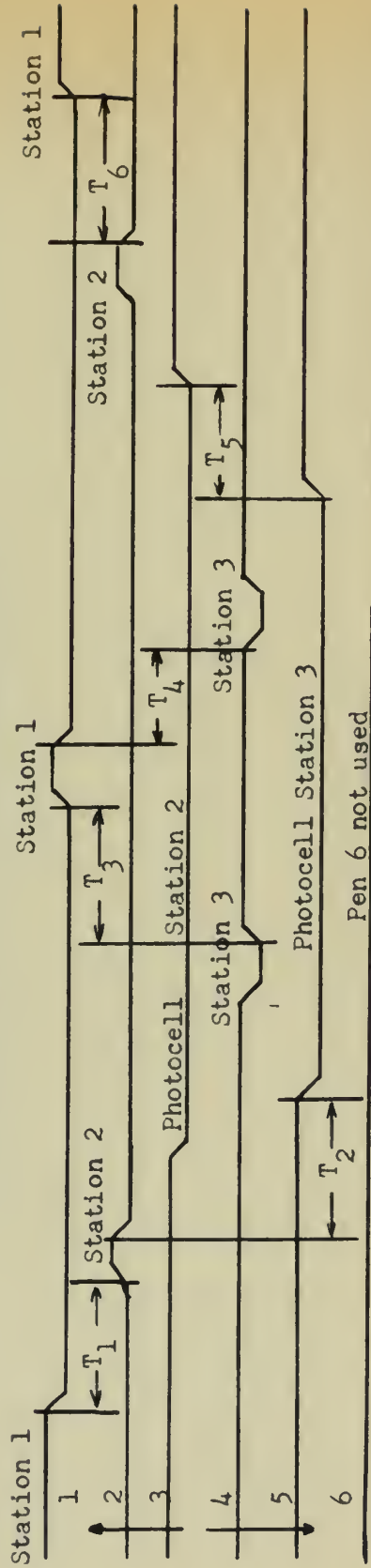



1 and 3 were deflected. This means that the operator's thumb was in contact with station 1, and the cube was in position at station 2. Lines 2, 4, and 5 were in their normal position which means that these circuits were open. Transport 1 ( $T_1$ ) was a transport empty from station 1 to station 2.  $T_1$  on the tape shows that it was measured from the instant that contact was broken at station 1 until the instant that contact was made at station 2. Transport 2 ( $T_2$ ) was a transport loaded from station 2 to station 3.  $T_2$  on the tape shows that it was measured from the instant that contact was broken at station 2 until the instant that the photoelectric cell was actuated at station 3. Transport 3 ( $T_3$ ) was a transport empty from station 3 to station 1.  $T_3$  on the tape shows that it was measured from the instant that contact was broken at station 3 until the instant that contact was made at station 1. Transport 4 ( $T_4$ ) was a transport empty from station 1 to station 3.  $T_4$  on the tape shows that it was measured from the instant that contact was broken at station 1 until the instant that contact was made at station 3. Transport 5 ( $T_5$ ) was a transport loaded from station 3 to station 2.  $T_5$  on the tape shows that it was measured from the instant that the photoelectric cell at station 3 was actuated until the instant that the photoelectric cell at station 2 was actuated. Transport 6 ( $T_6$ ) was a transport empty from station 2 to station 1.  $T_6$  on the tape shows that it was measured from the instant that contact was broken at station 2 until the instant that contact was made at station 1. As the arrow at the beginning of the tape indicates, kymograph pens 1, 2, and 3 deflect in the opposite direction from pens 4, 5, and 6. Pen 6 was not used during this experiment.



Figure 9 shows a wiring diagram of the electrical devices used in the experiment.

#### Test Procedure

Twelve naval officer students in Industrial Engineering at Purdue University were chosen as subjects for the experiment. Each subject viewed the physical setup and was given a thorough explanation of the procedure to be used during the administration of the experiment. Figure 10 shows the instructions which were given to each subject before the practice session and again before the recorded runs. Each subject was given approximately twenty minutes of practice to become completely familiarized with the equipment and the operation cycle. Since the two-inch metal block weighed only four ounces and the recorded runs of five cycles each were extremely short, it was felt that the element of fatigue could be neglected. In order to make final preparations for the recorded runs and to standardize the administration of the experiment as much as possible, each subject was given about five minutes rest before any recorded runs were made.

Phase A of the experiment was conducted first. The subjects were instructed to work as rapidly as possible. In order to obtain as steady a performance rate as possible no measurements were taken until the start of the fourth cycle. The kymograph was started at the commencement of the first cycle, but these measurements were ignored. As the subject commenced  $T_4$  of the third cycle, the camera operators were alerted by the experiment-supervisor. At the commencement of  $T_6$  of the third cycle, the supervisor signalled for the cameras to



Wiring Diagram of Electrical Devices

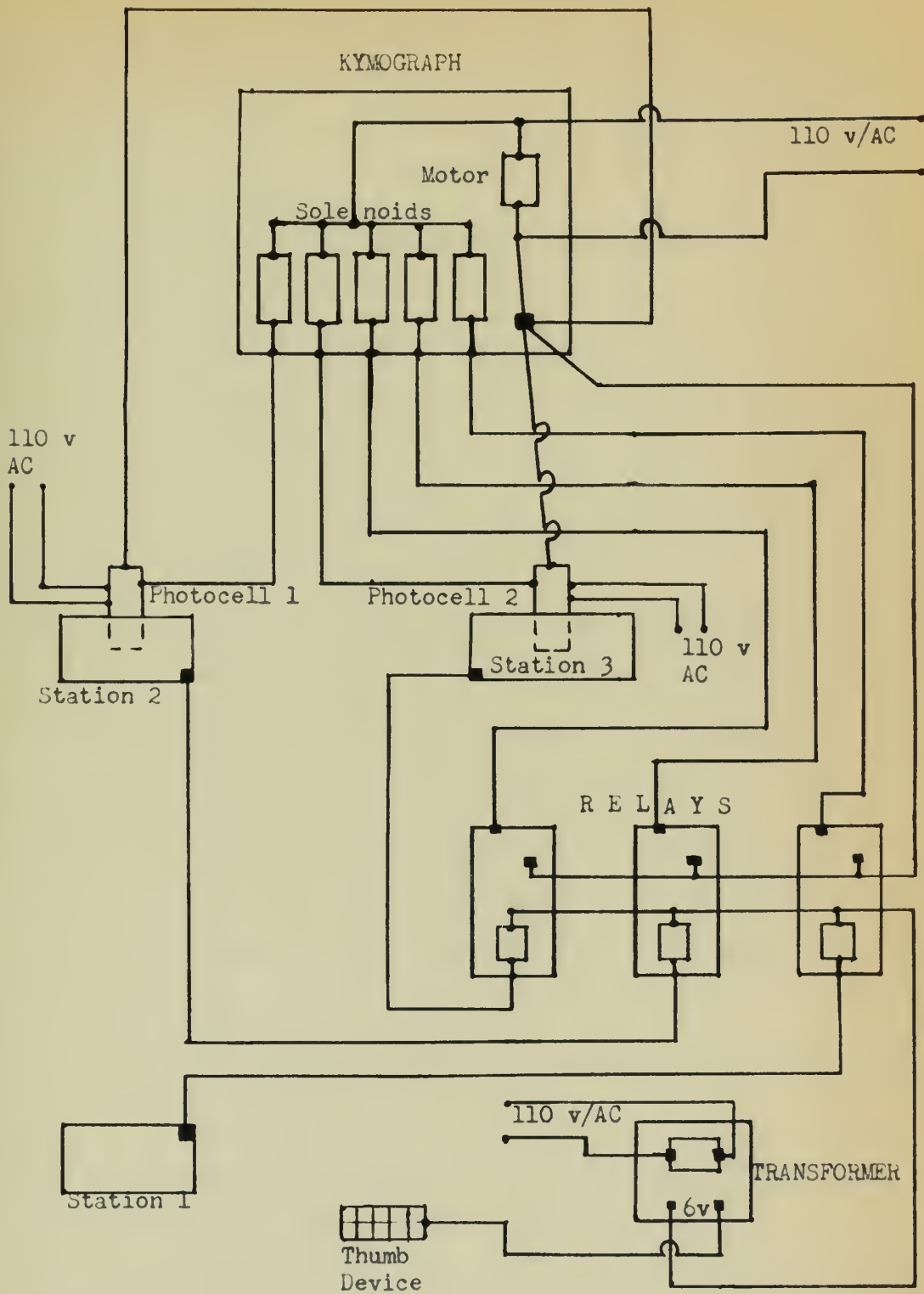



Fig. 10

## Instructions for Operators

1. The experiment in which you are about to take part consists of performing a simple task with your right hand at three rates of performance.

2. The motion paths and the therbligs involved in this task are as follows:

- a. Contact grasp front of plate at station 1.
- b. Transport empty from station 1 to station 2.
- c. Grasp the cube at station 2 by placing the thumb on the near side of the cube and the first three fingers on the opposite side.
- d. Transport loaded from station 2 to station 3.
- e. Position cube and assemble as required at station 3. Do not drop cube -- place firmly on surface before releasing.
- f. Release load cube at station 3.
- g. Transport empty from station 3 to station 1.
- h. Contact grasp front of plate at station 1 with thumb.
- i. Transport empty from station 1 to station 3.
- j. Grasp cube at station 3.
- k. Disassemble as required at station 3 and transport loaded to station 2.
- l. Position and release load cube at station 2. Do not drop cube -- place firmly on surface before releasing.
- m. Transport empty from station 2 to station 1.



Fig. 10 (Cont'd)

n. Contact grasp front of plate at station 1 with thumb.

3. A recorded and photographed run will be taken for each phase-variation of the task and will consist of approximately five to seven cycles as described above.

4. For phase A work as rapidly as you can.

5. For phase B work at seventy-five percent of your maximum performance rate.

6. For phase C work at about fifty percent of your maximum performance rate.

7. To assist you in attaining the desired rates of performance for phase A and phase B a timer will check your training cycle times. This timer will adjust your performance rate by the commands of "slower" or "faster". An identical performance-timing procedure will be followed during the recorded run.

8. You will have at least five minutes rest between recorded runs to enable the final preparations for the next phase to be completed.

9. During the recorded runs continue to work until you are told to stop.



be started. This enabled the cameras to be operating at the selected speeds by the time of commencement of  $T_1$  of the first measured cycle. For phase A both of the camera speeds were 32 frames per second. Approximately fifteen feet of film was used per camera for each operator. This amount of film covered from six to seven cycles of the task, depending upon the speed and the dexterity of the operator.

Phase B of the experiment was conducted secondly. For this phase the operator was requested to work at approximately seventy-five percent of his maximum performance rate. Preliminary investigations indicated that the cycle time for a consistent performance rate at this level was slightly different for each operator. Also, the maximum performance rates had varied. Consequently, a time range of 0.065-0.080 minutes was selected as the desired cycle time. During the training period the operator was timed by means of a repetitive accumulative timing device. His performance rate was adjusted by commands of "slower" or "faster" from the timer. The training period continued until the operator was accomplishing the task consistently at a performance rate whose cycle time was within the selected range. Rest periods were given both during and at the end of the training period. An identical performance-timing procedure was followed for the recorded run. As soon as the operator was again performing consistently at the desired rate, the timer signalled for the kymograph and the cameras to be started. For phase B, both of the camera speeds were 32 frames per second. Approximately twenty feet of film was used per camera for each operator. This amount of film covered five cycles of the task.



Phase C of the experiment was conducted last. For this phase the operator was requested to work at approximately fifty percent of his maximum performance rate. For the same reasons as those stated for phase B, a time range of 0.090-0.100 was selected as the desired cycle time. A training and timing procedure identical to that of phase B was employed. For phase C, both of the camera speeds were 16 frames per second. Approximately fifteen feet of film was used per camera for each operator. This amount of film covered from five to six cycles of the task.

For all phases of the experiment, the camera lenses were centered on selected points on the cross-sectioned paper. The plan-view camera lens was centered on the intersection of the 9.25 inch abscissa and the 10 inch ordinate of the horizontal background. The side-view camera lens was centered on the intersection of the 9 inch abscissa and the 4 inch ordinate of the vertical background.

The knuckle of the operator's right index finger was selected to be the measured point for the analysis of the motion path. Two black-tape circles of approximately  $5/16$  inch diameter were affixed to the operator's hand, one just above the selected knuckle and the other on the side of his hand in line with the knuckles.

The operators were seated on a chair with a backrest. The chair height was adjusted so that when the operator's arm was hanging by his side his elbow was at a distance of 35 inches from the floor. The chair was also so adjusted that when each operator's arm was fully extended in front of him the tips of his fingers were above the 20 inch ordinate of the horizontal background.



Some of the variables that were not controlled were:

1. Activity of the subjects outside of the laboratory, both mental and physical.
2. The emotional states of the subjects.
3. Motivation of the subjects.
4. The twelve subjects do not necessarily represent a reliable random sample of the industrial population.



## ANALYSIS OF RESULTS

The spacings between indications of the kymograph tape were measured with an engineering scale to the closest one-fiftieth of an inch, and these measurements were converted to corresponding time values by the use of the predetermined conversion factor of one inch being equal to 0.0018 minute. Each transport therblig and each overall cycle was measured for performance time, and these time values are tabulated in Tables 1 through 12 of Appendix A for the twelve operators.

The motion picture films were analyzed in accordance with the following procedure: the films from the plan-view and the side-view cameras were viewed simultaneously by utilizing two projectors. The projected views were initially inspected to ensure that the same cycle was being viewed on both of them. Since the cameras had been started at nearly identical times, the first few frames of both films were viewed and adjusted as necessary in the projectors until both projectors were showing the commencement of  $T_1$  of the first recorded cycle. Following the analysis of  $T_1$  the films were moved in unison to the commencement of  $T_2$  and likewise through all of the photographed transport therbligs of the particular phase.

The first step in the analysis of a particular transport therblig was to analyze the side-view film to determine the approximate location of the maximum deviation of the motion path as measured in a vertical direction from the reference line. Then, the plan-view film of the same path was analyzed to determine the approximate location of the maximum deviation of the motion path as measured in a horizontal



direction from the reference line. Several points approximately one-half inch apart were selected on the reference line in the proximity of the maximum horizontal and vertical deviations of the motion path from this reference line. These two components of deviation were measured on the grid surfaces, after being corrected for the convergence of light. Then these components were added vectorially to obtain the true deviation. The maximum true deviation was selected from the values thus calculated for use in this experiment. The procedure developed by Smalley<sup>15</sup> was used to determine and apply the necessary corrections. The formulae used and sample calculations are shown in Table 13 of Appendix B. The maximum true deviations from the reference line for each path were recorded as the motion path variations in Table 1 through 12 of Appendix A.

The effect of each of the two main variables of the data and of their interaction was investigated, using the statistical tool known as the Analysis of Variance<sup>16</sup>. The particular method used was the factorial design with replication. The computational formulae together with sample calculations are shown in Table 14 of Appendix B. The

---

<sup>15</sup>Smalley, H.E., (op. cit.), pp. 18-21.

<sup>16</sup>Snedecor, G.W., Statistical Methods, Collegiate Press, Ames, 1937, Chapters 10 and 11.



intermediate data is shown in Table 15 of Appendix B. For the motion path of each transport therblig, the variances due to the operators, to the performance rates, and to their interaction were sorted out from the total variance by computing the F ratios. These computed F ratios were compared with the tabulated F values<sup>17</sup>. The results of the comparisons are shown in Table 16 of Appendix B.

The Analysis of Variance showed the performance rates, the operators, and the interactions all to be significant variables at the one per cent level of significance for all six motion paths, considering the experiment to be a fixed model.

The components of variation were then computed as shown in Table 17 of Appendix B. The results of these computations are tabulated in Table 18 of Appendix B. The results indicate the percentage of the total variation that can be attributed to a particular source of variation. The largest percentage of variation in all cases is that due to the operators. Percentages of the other sources of variation, ranked in descending magnitude, are: interaction, error, and performance rate.

The Tukey<sup>18</sup> Method of multiple comparison in pairs permitted the comparison of the means of Phase A (fast performance rate) versus Phase B (intermediate performance rate), Phase A versus Phase C (slow performance rate), and Phase B versus Phase C to be handled as outlined in Table 19 of Appendix B. To make the multiple comparison it was necessary to check the  $\theta'$  confidence intervals.

---

<sup>17</sup>Snedecor, G.W., (op. cit.), Table 10.2 pp. 184-187.

<sup>18</sup>Tukey, J.W., "Comparing Individual Means in the Analysis of Variance," Biometrika 5, 1949, pp. 99-114.



If these confidence intervals did not overlap zero, it could be stated that a significant difference exists between the means being compared. Table 20 of Appendix B records the intermediate data used in making the multiple comparisons. The results of the multiple comparison of the phases of the motion paths and the rank order of magnitude of the means are tabulated in Table 21 of Appendix B.

The rank order of the means indicates that the mean deviations of motion paths 2 and 5 are significantly different between the fast and the intermediate performance rates. The mean deviations of motion paths 1, 3, 4, and 6 are significantly different between the intermediate and the slow performance rates. The mean deviations of all motion paths are significantly different between the fast and the slow performance rates.



## CONCLUSIONS AND RECOMMENDATIONS

The results of the Analysis of Variance listed in Table 16 of Appendix B show that a significant difference exists in the motion paths used at standardized performance levels. This would indicate that pace rating through observation of speed of movement may be erroneous since the performance time required to make a given movement may vary due to minute variations in motion path even though the speed of movement remains constant.

The operator and the operator x performance rate interaction were also found to be significant sources of variation by the Analysis of Variance. The significance of the operator term denotes that different operators have different motion paths for a standardized performance level. The significance of the interaction term denotes that, as the performance rate changed, the effect of an operator upon the motion path variations was not always the same. A study of the operator data tables of Appendix A will illustrate some of these differences. For example, the motion path measurements for operator 12 increased in magnitude as the performance rate became slower. Consequently it may be assumed that the length of his motion path increased as his performance rate decreased. The average motion path measurements of operator 7 decreased in magnitude as the performance rate became slower. Thus it may be assumed that the length of his motion path decreased as his performance rate decreased. In the case of other operators, such as operator 1, some of the average motion paths became smaller, some became larger and some remained approximately the same as the performance rate became slower. These



differences indicate that, for the conditions of this experiment, the motion paths of various operators do not follow any general pattern as to the amount or the type of their changes as the performance rate changes.

The values of the particular sources of variation and the percentages of the total variation which can be attributed to these particular sources are listed in Table 18 of Appendix B. Although the percentages of variation due to performance rate are relatively small, they are statistically significant. The large percentages of variation due to operators may be explained in part by the physical differences of the operators. Also, such unmeasured variables as motivation and emotional state could have been major causes of these operator variations.

The values of the total source of variation listed in Table 18 of Appendix B show that the variation of the measurements of the motion path for all three performance rates is the least for paths 2 and 5 and the greatest for paths 1 and 3. The possibility exists that motion paths of the extended hand from side to side may be more uniform for various operators than those motion paths consisting of hand movements to and from the operator.

The results of the multiple comparison of means as listed in Table 21 of Appendix B show that the mean values of the measurements of the motion paths are not significantly different for all comparisons of the performance rates. The rank order of the mean values indicates that there was always a significant difference of mean values between the fast and the slow selected performance rates. However, the mean



values of the intermediate performance rate were not consistent in their significant difference. Since the Analysis of Variance has shown that there is a significant relationship between the motion path variations and the performance rate, it may be concluded that although the performance levels of the slow rate and of the fast rate were sufficiently different to display different motion paths, the performance level of the intermediate rate tended to approximate that of either the fast level or the slow level, depending upon the path.

It is considered that the results of this investigation have indicated some of the relationships between the minute motion path variations and operator performance. It is realized that there are other variations of operator movements, such as velocity, which are important factors in the rate of performance. Therefore, it is recommended that further study of motion path variations be made to evaluate the magnitude of the effect of these variations upon performance time. This might be accomplished by comparison of extensive pace ratings against measured average motion path velocities and terminal point hand motions.



## APPENDIX A

DATA FROM INDIVIDUAL SUBJECTS



Table 1. Data for Operator 1

Age: 28                      Weight: 160                      Height: 5'5"                      Chest: 37"

Time Measurements:  $10^{-3}$  minutes

Variation (Var.) of Motion Path: inches

Transport Therblig	Phase A		Phase B		Phase C	
	Time	Var.	Time	Var.	Time	Var.
1	6.3	4.9	7.7	5.1	10.4	4.9
	7.4	4.9	8.8	4.9	9.2	4.9
	5.4	4.4	8.7	4.9	8.7	4.7
	5.1	5.1	9.4	4.9	9.0	4.7
	5.8	5.3	8.2	4.9	9.6	4.0
2	5.7	6.7	7.3	6.9	9.1	6.5
	6.0	6.9	7.8	7.1	8.4	6.3
	5.8	6.3	7.5	6.9	10.1	6.7
	6.9	6.5	7.9	7.1	9.0	6.9
	5.9	6.3	7.7	7.3	9.3	6.9
3	6.6	5.8	9.6	5.6	10.9	5.6
	7.1	5.8	8.7	5.2	10.8	5.8
	6.6	5.6	10.2	5.6	9.8	6.0
	6.9	5.4	9.3	6.0	10.2	6.0
	7.2	5.7	10.4	6.0	10.4	5.8
4	7.4	6.0	8.1	5.6	10.6	5.2
	7.5	5.8	8.6	5.2	11.3	5.0
	7.2	5.4	9.1	5.6	14.3	5.2
	7.5	5.6	8.8	5.6	13.2	5.4
	7.1	5.7	9.0	5.2	10.1	5.2
5	5.7	7.6	6.1	7.5	6.8	7.1
	5.8	7.6	6.4	7.1	8.1	7.3
	5.8	7.3	6.1	7.5	7.6	7.5
	5.4	7.1	6.5	7.5	7.5	7.3
	5.7	7.4	6.5	7.1	7.1	7.3
6	6.5	5.3	7.4	4.9	7.9	5.3
	5.9	4.9	8.5	5.3	8.2	5.5
	6.0	4.9	10.1	5.5	9.0	5.8
	6.2	5.3	9.1	5.3	9.6	5.8
	5.9	5.1	8.5	5.3	10.4	5.8
Total Cycle Time	52.9	-	75.6	-	90.0	-
	52.9	-	70.2	-	86.8	-
	52.6	-	74.0	-	90.7	-
	54.0	-	74.7	-	89.3	-
	54.4	-	72.9	-	88.6	-



Table 2. Data for Operator 2

Age: 32                      Weight: 205                      Height: 6'2"                      Chest: 41"

Time Measurements: 10<sup>-3</sup> minutes

Variation (Var.) of Motion Path: inches

Transport Therblig	Phase A		Phase B		Phase C	
	Time	Var.	Time	Var.	Time	Var.
1	4.8	5.8	10.2	6.7	14.3	7.3
	5.5	6.9	10.6	6.2	11.9	7.4
	5.2	6.4	8.8	6.4	13.0	7.4
	5.4	6.8	8.8	6.5	11.5	7.3
	5.2	6.6	9.4	6.2	14.3	7.3
2	4.1	8.1	5.7	7.9	8.5	8.7
	4.4	8.1	6.7	7.9	8.9	8.7
	4.8	7.5	5.8	7.9	8.3	8.5
	4.3	7.9	6.9	7.9	8.2	8.1
	4.7	8.1	7.6	7.9	9.6	8.1
3	7.5	8.6	10.9	8.0	13.4	8.7
	5.7	8.5	10.1	7.5	12.3	8.3
	5.5	9.0	10.5	7.6	11.7	8.1
	6.8	8.6	9.8	7.6	11.6	8.1
	6.0	8.1	10.5	7.8	12.4	8.6
4	5.6	6.7	10.2	7.3	14.4	8.5
	5.7	7.7	8.7	6.7	12.3	7.8
	5.4	7.3	9.2	6.9	13.7	7.6
	5.9	6.6	8.5	7.2	13.2	7.6
	5.6	7.2	9.2	7.7	14.1	7.8
5	4.5	8.2	6.5	7.8	7.4	8.7
	4.6	8.6	6.2	7.7	8.5	8.8
	4.6	8.5	6.6	8.1	7.8	8.8
	4.6	8.1	6.7	7.4	7.3	8.5
	5.2	8.5	5.9	7.8	8.0	8.5
6	6.1	7.5	8.8	7.5	11.8	7.2
	5.5	7.4	9.2	6.7	12.3	7.4
	6.3	7.6	9.3	7.4	10.6	7.3
	6.1	7.5	8.9	7.2	11.3	7.4
	6.1	7.6	8.6	7.1	11.4	7.1
Total Cycle Time	49.0	-	72.4	-	92.7	-
	47.9	-	71.1	-	93.8	-
	47.9	-	69.3	-	89.6	-
	49.5	-	70.0	-	95.8	-
	50.0	-	71.3	-	96.5	-



Table 3. Data for Operator 3

Age: 34                      Weight: 165                      Height: 5'9"                      Chest: 36½"

Time Measurements: 10<sup>-3</sup> minutes

Variation (Var.) of Motion Path: inches

Transport Therblig	Phase A		Phase B		Phase C	
	Time	Var.	Time	Var.	Time	Var.
1	4.4	5.5	7.9	5.8	9.3	7.1
	4.3	5.5	10.5	6.0	10.8	7.1
	4.5	5.5	9.0	5.8	11.9	6.6
	4.7	4.9	8.5	5.8	10.7	7.1
	5.1	5.5	9.2	5.5	10.5	6.6
2	4.1	6.9	6.0	6.7	7.1	7.7
	4.2	6.3	6.5	7.1	8.2	7.7
	4.2	6.3	6.3	6.5	8.0	7.3
	3.9	6.3	6.0	6.9	7.3	7.5
	4.2	6.9	6.7	6.9	7.4	7.5
3	5.8	6.0	9.8	6.4	11.9	8.3
	5.5	6.4	10.4	6.9	11.4	7.8
	6.1	6.4	10.1	7.3	12.8	7.1
	5.3	6.0	10.1	7.1	10.9	7.2
	5.8	6.4	10.9	6.9	10.6	8.2
4	5.2	5.6	9.9	6.6	11.6	6.9
	5.3	6.2	10.1	6.6	12.6	7.1
	5.3	5.6	9.4	6.9	12.2	7.2
	5.5	5.6	10.6	6.4	11.9	7.1
	5.4	6.2	10.2	6.4	12.4	7.2
5	3.8	7.4	6.0	7.2	6.9	7.6
	4.2	7.2	6.4	7.0	6.8	7.6
	4.3	7.4	6.4	7.6	7.5	7.6
	4.7	6.4	6.0	7.4	7.0	7.2
	4.5	7.4	6.5	7.1	7.1	7.4
6	5.6	5.8	10.0	6.2	9.9	7.1
	4.9	5.8	8.7	6.6	11.4	6.8
	5.5	6.2	8.8	5.9	10.4	7.1
	5.2	6.0	9.5	6.6	11.6	6.8
	5.0	6.4	10.0	6.3	8.8	6.9
Total Cycle Time	41.2	-	69.3	-	84.8	-
	47.0	-	70.9	-	87.8	-
	42.1	-	70.4	-	89.3	-
	44.3	-	72.9	-	87.3	-
	42.5	-	73.4	-	81.7	-



Table 4. Data for Operator 4

Age: 33                      Weight: 165                      Height: 5'11"                      Chest: 39"

Time Measurements:  $10^{-3}$  minutes

Variation (Var.) of Motion Path: inches

Transport Therblig	Phase A		Phase B		Phase C	
	Time	Var.	Time	Var.	Time	Var.
1	4.3	6.2	8.3	6.2	10.1	6.6
	4.0	6.2	8.9	6.6	11.3	6.0
	4.1	6.2	7.8	6.2	12.5	5.1
	4.0	6.2	8.0	6.2	12.7	6.0
	4.2	6.2	8.4	6.2	13.2	6.2
2	4.2	7.3	6.7	7.1	8.3	6.5
	4.3	7.3	7.3	6.5	8.2	6.7
	4.2	7.3	6.8	6.9	9.2	6.7
	3.7	7.3	6.7	7.3	9.9	6.9
	4.0	8.1	6.7	7.3	8.7	6.9
3	4.6	6.6	8.4	5.6	11.6	6.4
	4.6	6.6	8.6	6.5	12.7	6.6
	5.1	6.4	9.1	6.9	12.4	6.6
	4.6	6.6	8.9	7.2	12.3	6.6
	4.5	6.9	9.0	6.6	13.8	6.6
4	4.4	6.2	8.3	5.6	11.7	6.4
	4.6	6.0	7.8	6.4	12.0	6.4
	4.6	6.4	7.7	6.9	12.9	6.4
	4.1	6.4	8.7	6.9	11.5	6.6
	4.4	6.4	8.8	6.6	12.2	6.4
5	4.2	7.2	6.8	7.1	9.1	6.8
	4.6	8.0	6.7	6.8	9.0	7.1
	4.6	7.6	7.0	6.8	9.9	6.6
	4.0	7.6	6.7	6.6	8.3	7.2
	4.4	8.0	7.6	7.2	8.1	7.2
6	4.1	6.4	8.1	6.2	11.5	5.1
	4.0	6.2	9.0	5.8	12.5	5.8
	4.0	6.0	9.0	6.2	12.6	5.8
	3.8	6.6	8.7	6.2	12.5	5.5
	4.0	6.2	8.0	5.8	12.9	5.8
<b>Total</b> Cycle Time	36.2	-	64.4	-	88.0	-
	37.1	-	66.2	-	90.9	-
	37.1	-	65.9	-	94.3	-
	37.4	-	66.8	-	92.7	-
	36.2	-	66.8	-	93.8	-



Table 5. Data for Operator 5

Age: 32                      Weight: 140                      Height: 5'7½"                      Chest: 35"

Time Measurements: 10<sup>-3</sup> minutes

Variation (Var.) of Motion Path: inches

Transport Therblig	Phase A		Phase B		Phase C	
	Time	Var.	Time	Var.	Time	Var.
1	6.3	5.7	9.4	5.3	15.5	5.1
	6.5	5.7	9.5	5.3	15.2	5.1
	6.5	5.4	10.6	5.3	13.5	4.9
	6.5	5.3	8.6	5.3	13.9	5.3
	5.5	5.3	10.1	5.2	14.9	5.1
2	5.6	5.6	7.5	7.3	8.9	7.3
	5.2	7.3	7.4	7.3	8.8	6.9
	5.5	7.1	6.9	7.3	9.3	6.7
	5.2	7.1	7.1	7.3	9.5	7.3
	5.3	7.3	7.3	7.1	10.0	6.7
3	7.6	5.2	9.8	6.4	14.3	6.4
	7.6	5.6	10.8	6.4	14.0	6.4
	7.3	5.4	9.4	6.4	13.1	6.4
	7.0	5.6	11.4	6.4	15.1	6.4
	7.0	5.6	11.3	6.4	13.2	6.2
4	6.7	6.0	9.8	6.4	14.0	5.6
	6.7	6.4	10.7	6.4	13.2	5.6
	6.1	6.2	11.2	6.4	13.4	6.2
	7.1	6.4	10.6	6.4	16.1	5.2
	6.8	6.0	10.6	6.4	13.9	5.6
5	5.6	7.2	6.8	7.2	7.8	6.8
	4.8	7.2	7.4	7.4	8.0	7.0
	4.9	6.8	7.0	7.2	9.2	7.2
	5.2	7.6	7.4	7.2	7.3	6.8
	5.2	7.6	7.1	7.2	8.7	6.9
6	6.0	5.5	9.4	5.1	14.8	5.3
	6.3	5.5	10.1	5.5	15.9	5.3
	6.2	5.1	9.9	5.9	13.0	5.6
	5.6	5.1	11.4	5.5	12.9	5.6
	6.3	5.3	10.6	5.5	13.5	5.5
Total Cycle Time	45.2	-	69.3	-	104.8	-
	48.2	-	74.2	-	102.4	-
	47.9	-	74.7	-	100.4	-
	46.4	-	76.0	-	104.6	-
	46.8	-	74.2	-	106.6	-



Table 6. Data for Operator 6

Age: 30                      Weight: 158                      Height: 5'9"                      Chest: 38"

Time Measurements:  $10^{-3}$  minutes

Variation (Var.) of Motion Path: inches

Transport Therblig	Phase A		Phase B		Phase C	
	Time	Var.	Time	Var.	Time	Var.
1	6.1	6.5	10.0	6.6	14.6	6.4
	6.1	6.7	11.5	6.8	14.8	6.2
	6.8	6.1	11.0	6.4	14.7	7.1
	5.9	6.7	8.8	6.4	14.6	6.8
	6.2	6.8	9.9	6.6	13.0	7.1
2	8.2	8.1	8.2	7.9	11.7	7.3
	7.6	8.1	8.2	7.7	10.2	7.3
	6.8	7.7	7.9	7.5	9.5	7.5
	7.2	7.9	8.4	7.3	10.1	7.7
	7.4	7.9	8.5	7.9	9.6	7.3
3	6.2	7.1	10.3	6.9	12.3	7.6
	5.7	6.9	10.1	7.1	13.2	7.3
	5.4	7.1	10.0	7.3	12.2	7.5
	6.3	7.3	10.0	6.9	13.8	7.3
	5.7	6.6	10.5	7.4	13.1	7.7
4	6.4	6.9	11.3	6.7	14.7	7.5
	6.4	7.2	9.2	7.4	13.0	6.6
	6.7	6.9	11.0	6.7	12.2	6.9
	6.5	6.9	10.8	6.5	12.4	6.9
	6.4	6.6	10.9	7.2	12.5	7.7
5	7.9	8.0	7.0	7.4	8.1	7.2
	7.1	8.0	6.9	7.8	8.3	7.2
	6.9	8.0	7.7	7.6	8.1	7.6
	7.0	7.6	6.3	7.2	8.2	7.0
	7.5	8.6	6.8	7.2	7.9	7.4
6	5.0	6.2	10.5	6.6	11.4	7.3
	4.3	6.0	10.9	6.6	12.4	6.8
	5.3	6.2	8.8	6.6	12.3	6.6
	4.7	6.6	8.7	6.8	13.4	7.3
	5.3	6.1	10.6	7.1	12.0	7.5
Total Cycle Time	45.2	-	77.8	-	98.3	-
	46.4	-	76.5	-	97.2	-
	49.0	-	77.4	-	96.3	-
	47.5	-	77.0	-	97.2	-
	45.9	-	77.8	-	93.2	-



Table 7. Data for Operator 7

Age: 31                      Weight: 178                      Height: 6'1"                      Chest: 37½"

Time Measurements: 10<sup>-3</sup> minutes

Variation (Var.) of Motion Path: inches

Transport Therblig	Phase A		Phase B		Phase C	
	Time	Var.	Time	Var.	Time	Var.
1	6.6	6.6	8.7	6.4	10.3	5.8
	6.5	7.1	9.1	6.4	11.3	5.3
	6.2	6.9	8.5	6.8	11.5	6.2
	7.0	6.6	9.5	6.6	11.6	6.2
	6.9	7.1	7.5	6.2	10.9	5.9
2	5.8	8.3	7.4	8.1	8.5	7.7
	5.5	8.5	7.9	8.3	8.6	8.3
	5.6	8.5	7.5	8.9	8.6	8.1
	5.4	8.3	7.0	9.4	8.2	7.7
	5.0	8.5	7.6	8.9	8.1	7.5
3	7.1	8.8	10.5	8.2	11.7	6.5
	7.6	9.0	8.6	8.4	11.6	7.1
	7.6	9.6	11.0	8.8	11.7	7.0
	6.9	9.0	8.7	8.7	10.3	7.3
	7.0	8.8	9.5	7.3	11.1	7.5
4	7.2	8.8	8.6	7.7	9.5	6.0
	7.2	8.6	8.6	7.9	10.4	6.3
	6.6	8.6	9.3	8.1	9.0	6.1
	7.5	8.6	9.2	8.1	8.9	5.6
	6.8	7.9	8.7	7.9	8.3	6.4
5	4.2	8.0	7.0	7.8	7.2	7.6
	4.4	8.4	6.5	7.2	7.2	8.2
	5.1	8.6	6.2	8.4	7.2	7.6
	4.6	8.4	6.3	8.4	7.0	7.4
	4.2	8.0	6.2	7.8	6.4	7.6
6	5.8	7.2	8.2	6.8	9.1	5.3
	6.8	8.4	8.3	7.1	10.4	6.4
	5.8	7.8	9.2	7.5	11.2	5.3
	6.0	7.2	8.3	6.4	11.6	6.2
	5.4	7.3	8.4	6.6	11.0	6.2
Total Cycle Time	53.8	-	74.6	-	88.3	-
	55.1	-	74.4	-	88.3	-
	53.8	-	78.2	-	88.3	-
	53.1	-	73.0	-	88.8	-
	54.7	-	72.8	-	87.8	-



Table 8. Data for Operator 8

Age: 30

Weight: 162

Height: 5'10"

Chest: 38½"

Time Measurements: 10<sup>-3</sup> minutes

Variation (Var.) of Motion Path: inches

Transport Therblig	Phase A		Phase B		Phase C	
	Time	Var.	Time	Var.	Time	Var.
1	5.5	5.3	10.2	6.0	11.3	6.4
	5.1	5.8	9.4	6.6	10.0	6.4
	5.3	5.8	8.6	5.8	10.2	5.8
	5.7	6.2	9.6	6.2	12.1	6.6
	5.6	6.0	8.2	5.8	12.7	6.0
2	4.9	7.1	8.2	7.3	10.1	7.3
	5.1	6.9	8.0	7.3	8.7	7.7
	5.4	7.1	8.2	7.7	8.7	7.3
	5.8	7.7	7.8	7.7	10.2	7.5
	5.1	7.7	8.0	7.3	9.1	7.7
3	5.5	6.4	9.9	6.6	12.6	7.3
	6.0	6.6	8.3	7.1	12.0	7.3
	5.2	7.1	10.4	6.6	10.8	7.0
	5.6	7.1	8.6	7.3	13.7	7.2
	6.6	7.1	9.4	7.3	10.9	7.5
4	5.6	6.6	9.1	5.7	11.4	7.0
	6.7	6.2	8.5	6.4	11.9	6.7
	6.1	6.9	9.1	6.6	12.0	6.5
	5.8	6.4	8.5	6.6	13.3	6.8
	6.3	6.4	8.0	5.6	13.9	6.7
5	5.4	7.6	7.1	6.8	7.3	7.0
	5.5	7.4	8.5	7.2	8.7	7.2
	5.1	7.6	7.6	7.4	7.8	7.2
	4.9	7.2	6.8	7.2	8.3	7.2
	5.3	7.4	7.5	7.0	7.3	7.4
6	4.7	5.8	8.8	5.5	9.6	6.6
	6.8	6.4	9.6	5.8	11.1	6.0
	5.2	5.9	8.6	5.2	11.5	6.0
	5.2	5.6	7.5	5.5	12.7	6.0
	5.2	5.8	7.8	5.5	12.6	6.0
Total Cycle Time	45.2	-	69.8	-	85.7	-
	44.6	-	70.2	-	86.6	-
	47.2	-	72.0	-	86.0	-
	42.5	-	70.2	-	93.8	-
	45.7	-	72.0	-	92.5	-

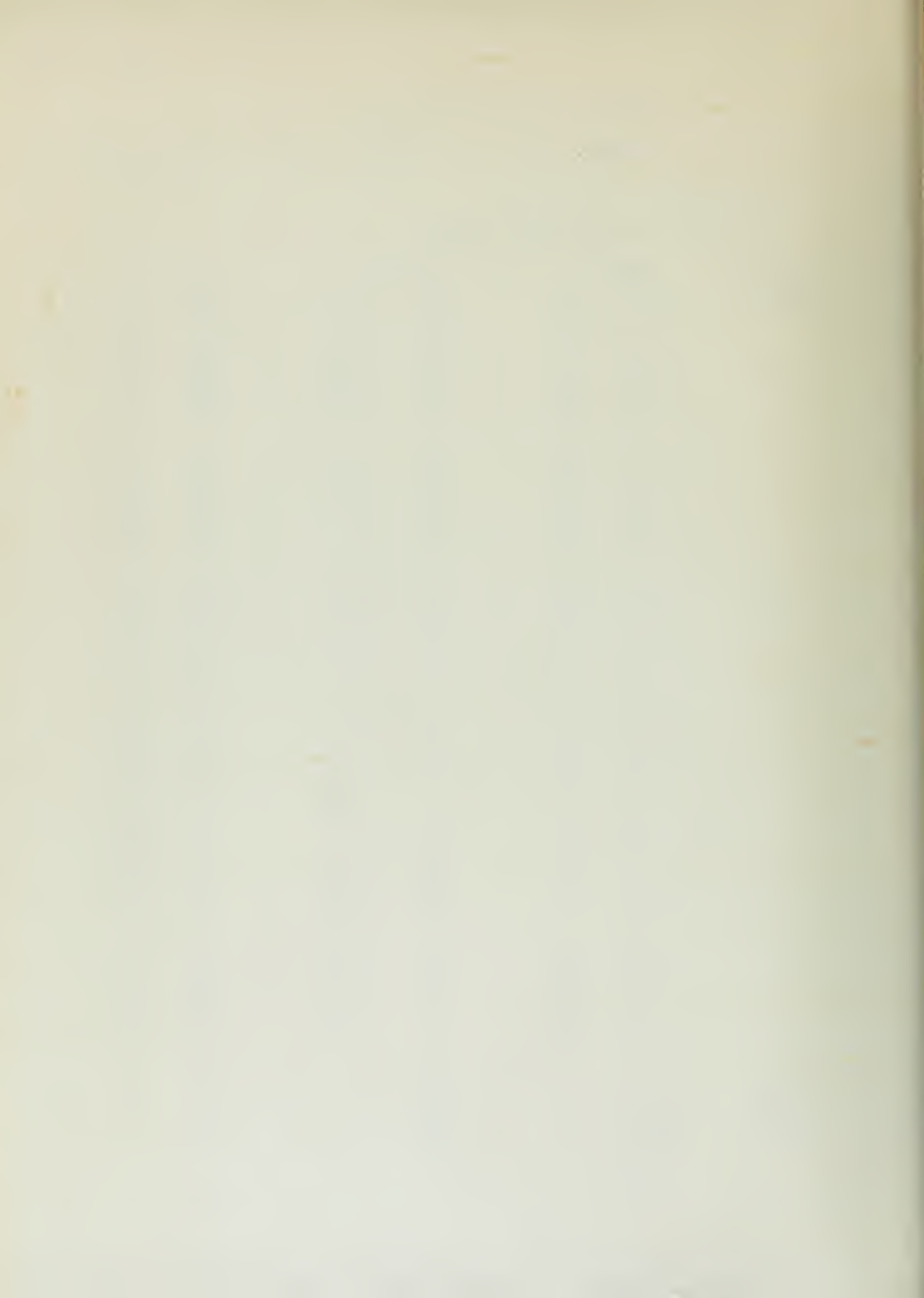

Table 9. Data for Operator 9

Age: 31                      Weight: 155                      Height: 5'6"                      Chest: 38½"

Time Measurements: 10<sup>-3</sup> minutes

Variation (Var.) of Motion Path: inches

Transport Therblig	Phase A		Phase B		Phase C	
	Time	Var.	Time	Var.	Time	Var.
1	6.0	5.3	8.1	5.3	9.4	5.5
	6.0	5.3	10.1	5.3	10.9	5.3
	6.0	5.1	8.2	5.3	11.2	5.4
	5.8	5.1	7.7	6.0	9.3	5.3
	5.4	5.3	8.0	5.8	8.8	5.1
2	5.1	7.3	7.4	6.9	7.7	6.5
	5.2	6.9	6.7	7.3	6.8	6.1
	5.3	7.1	7.0	6.9	6.9	6.5
	5.0	7.1	6.3	7.3	7.4	6.1
	4.8	6.9	6.2	7.5	7.2	6.5
3	7.0	5.8	10.1	5.6	10.6	4.8
	6.7	5.7	9.8	5.8	10.4	5.2
	7.2	6.3	9.1	6.0	10.8	5.6
	6.4	6.1	9.7	6.0	10.3	5.4
	6.6	5.8	9.4	5.2	12.1	5.2
4	6.4	5.8	8.4	6.0	9.1	6.6
	6.5	6.0	8.1	6.0	9.5	5.8
	6.3	6.0	8.2	6.6	10.8	6.2
	6.1	5.6	7.8	6.0	11.7	5.6
	6.3	5.6	7.7	5.8	10.9	5.6
5	5.3	7.2	6.5	7.0	6.2	6.6
	5.1	7.4	6.0	6.8	6.8	6.4
	5.0	7.6	6.2	7.0	7.3	6.6
	5.0	7.0	6.0	7.0	6.5	7.2
	5.3	7.2	6.2	6.6	7.3	6.6
6	6.0	5.1	8.5	4.7	10.4	4.8
	5.4	4.9	8.4	4.9	10.2	4.7
	6.0	4.9	8.1	4.9	10.3	4.8
	5.7	5.1	7.9	4.9	10.9	4.9
	5.8	5.1	8.7	4.9	10.0	4.8
Total Cycle Time	52.2	-	72.0	-	87.1	-
	50.6	-	71.6	-	85.7	-
	50.4	-	68.0	-	86.6	-
	51.1	-	67.3	-	90.2	-
	50.4	-	67.7	-	87.1	-



Table 10. Data for Operator 10

Age: 33                      Weight: 170                      Height: 5'10"                      Chest: 38½"

Time Measurements: 10<sup>-3</sup> minutes

Variation (Var.) of Motion Path: inches

Transport Therblig	Phase A		Phase B		Phase C	
	Time	Var.	Time	Var.	Time	Var.
1	5.8	5.3	9.4	6.1	11.7	6.6
	6.6	5.1	8.3	5.1	11.0	6.3
	6.5	5.5	9.3	5.4	12.5	6.2
	5.8	5.3	9.2	6.4	13.7	6.3
	6.2	5.5	9.8	5.4	11.6	6.3
2	6.4	6.9	7.4	7.9	8.5	7.5
	5.8	7.1	8.1	8.1	9.2	7.7
	5.9	7.3	7.3	7.7	10.6	7.9
	6.1	7.1	7.7	7.7	8.8	8.1
	5.4	7.1	7.5	7.7	10.2	7.7
3	6.8	5.9	8.7	6.4	11.6	6.7
	6.7	6.1	9.0	6.5	10.4	6.7
	7.6	6.1	8.7	6.6	10.9	6.4
	7.0	6.0	8.7	7.0	11.4	6.7
	6.2	6.0	9.8	6.4	10.1	7.6
4	6.5	6.4	11.8	6.7	12.2	7.0
	7.4	6.3	9.0	5.9	10.3	7.2
	7.5	6.5	11.3	6.4	12.2	8.0
	7.4	6.2	11.3	6.9	13.2	7.4
	6.7	6.4	10.5	6.5	12.1	7.4
5	5.4	7.2	6.7	7.0	7.5	7.6
	5.1	6.6	6.8	6.8	9.1	7.8
	5.3	7.6	7.0	7.6	7.4	7.6
	5.6	6.6	7.7	7.0	7.6	7.6
	6.2	6.8	7.3	7.2	8.3	7.6
6	6.3	5.6	13.1	5.5	10.4	6.4
	5.6	5.4	7.2	5.5	11.3	6.6
	5.9	5.8	8.0	6.0	10.1	6.4
	5.7	5.6	7.9	5.3	11.0	6.3
	5.4	5.1	8.4	6.0	16.9	6.3
Total Cycle Time	50.6	-	73.6	-	86.8	-
	50.6	-	70.0	-	88.6	-
	50.2	-	68.8	-	88.2	-
	49.7	-	72.0	-	90.9	-
	50.6	-	70.5	-	92.5	-



Table 11. Data for Operator 11

Age: 33      Weight: 192      Height: 6'  $\frac{1}{4}$ "      Chest: 41"Time Measurements:  $10^{-3}$  minutes

Variation (Var.) of Motion Path: inches

Transport Therblig	Phase A		Phase B		Phase C	
	Time	Var.	Time	Var.	Time	Var.
1	5.2	5.8	10.2	5.5	11.6	5.8
	6.8	5.5	9.4	5.8	11.3	5.8
	5.8	4.9	10.4	5.8	14.9	6.4
	5.3	4.9	11.2	5.8	12.4	5.8
	4.4	5.8	9.7	5.5	13.0	5.8
2	5.0	6.5	7.4	7.1	10.3	7.7
	6.7	6.9	7.7	7.5	10.0	7.7
	6.4	6.7	8.8	6.5	14.3	7.7
	5.8	6.9	8.1	7.3	9.0	7.1
	5.8	6.7	8.3	7.3	9.5	7.3
3	6.3	5.8	10.5	6.4	13.9	6.0
	6.7	6.0	11.5	6.4	14.1	5.9
	6.5	6.3	10.4	6.7	12.2	6.0
	5.9	6.0	11.3	6.1	14.4	5.6
	5.9	5.8	10.8	6.2	11.3	5.8
4	5.4	5.6	9.6	6.6	11.4	6.9
	5.6	5.6	9.7	6.0	11.7	6.7
	7.1	5.4	10.9	6.2	11.5	6.5
	5.9	5.4	10.8	6.5	12.9	6.4
	5.6	5.8	9.5	6.3	11.4	6.5
5	5.6	7.2	6.5	7.4	7.6	7.6
	5.3	7.6	7.5	7.6	7.4	7.0
	5.2	6.8	6.8	7.4	8.5	7.2
	5.0	7.6	7.0	7.6	7.3	7.2
	5.4	7.0	7.9	7.6	8.5	7.0
6	5.7	4.7	9.2	5.1	10.8	5.1
	4.9	5.1	9.9	5.8	12.3	5.8
	6.1	4.9	9.7	5.1	10.8	5.9
	13.9	4.9	8.9	5.5	13.3	5.3
	6.2	5.2	7.0	5.1	12.1	5.1
Total Cycle Time	59.0	-	76.7	-	95.4	-
	52.4	-	79.4	-	101.2	-
	52.0	-	83.2	-	100.8	-
	52.4	-	83.2	-	97.4	-
	55.8	-	79.7	-	100.1	-

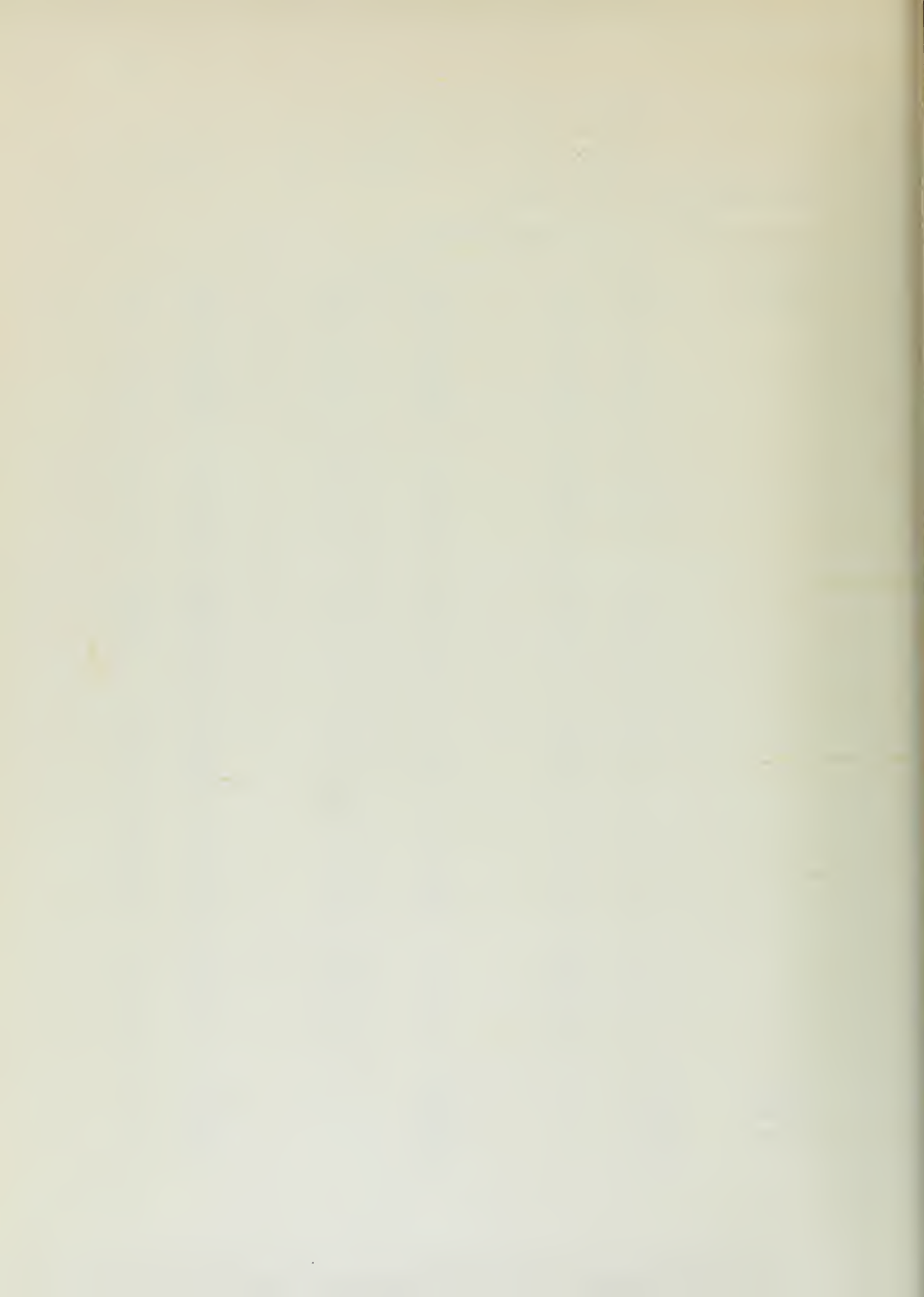

Table 12. Data for Operator 12

Age: 30                      Weight: 145                      Height: 5'7"                      Chest: 37½"

Time Measurements: 10<sup>-3</sup> minutes

Variation (Var.) of Motion Path: inches

Transport Therblig	Phase A		Phase B		Phase C	
	Time	Var.	Time	Var.	Time	Var.
1	6.7	6.8	9.7	6.8	13.0	9.5
	7.8	6.6	8.8	7.5	11.8	10.8
	6.1	6.6	10.0	8.0	13.5	9.7
	6.7	6.6	9.0	7.3	11.3	9.5
	6.3	7.1	9.1	7.1	11.5	8.6
2	5.7	7.7	7.8	7.5	8.5	8.9
	6.5	7.1	7.5	8.9	8.3	8.7
	5.6	7.1	7.1	7.7	8.2	9.1
	5.5	7.9	7.5	7.9	8.5	9.4
	5.7	7.1	7.6	8.3	8.1	8.9
3	7.6	7.1	9.8	6.9	13.5	8.3
	7.7	7.5	10.4	8.1	12.0	9.1
	8.3	7.2	10.6	7.3	12.7	8.7
	7.7	7.6	9.8	7.7	12.7	10.0
	6.5	7.3	10.8	7.1	14.2	10.5
4	6.5	5.6	8.6	6.9	13.4	9.9
	6.4	6.9	9.9	8.5	13.1	8.7
	7.7	6.9	9.1	6.6	12.5	9.1
	7.3	6.5	9.0	6.4	12.7	9.9
	6.3	6.4	8.9	6.9	12.2	8.9
5	5.4	7.8	6.7	7.0	6.7	8.6
	5.9	8.6	6.8	8.0	7.0	8.6
	5.2	8.4	6.6	7.2	7.4	8.4
	5.4	8.4	6.4	7.6	7.2	9.0
	5.2	8.4	6.6	7.6	7.0	8.6
6	6.7	6.9	8.3	6.8	13.0	8.2
	6.3	7.2	6.4	7.3	11.7	7.5
	6.4	6.9	10.1	6.6	12.5	8.3
	6.4	6.8	10.1	6.6	11.7	8.7
	7.0	6.9	10.9	7.3	12.6	9.3
Total Cycle Time	58.3	-	72.7	-	89.6	-
	62.3	-	73.4	-	85.3	-
	58.5	-	72.0	-	88.2	-
	58.3	-	70.4	-	84.6	-
	55.6	-	72.2	-	86.2	-



APPENDIX B  
CALCULATIONS



Table 13

## Correction of Photographic Measurements

Two formulae were used to determine the errors caused by the converging lines of light:

$$e_y = \frac{YZ}{S + Z} \quad \text{and} \quad e_x = \frac{XZ}{S + Z}$$

where  $e_y$  is the correction in the y-plane,

$e_x$  is the correction in the x-plane,

Y is the y-plane component of the observed measurement,

X is the x-plane component of the observed measurement,

S is the distance between the photographed object and the camera,  
and

Z is the distance between the photographed object and the cross-sectioned background.

A sample calculation is shown below. The data used is that of the side-view camera film of a  $T_1$  motion path when a particular point was observed to be at the intersection of the abscissa 12 and the ordinate 6 of the vertical background, the camera lens being aligned on the intersection of the abscissa 9 and the ordinate 4 of the same background:

$$e_y = \frac{(6-4)(14.75)}{104 + 14.75} = \frac{29.50}{118.75} = 0.25 \text{ inches}$$

$$e_x = \frac{(12-9)(14.75)}{104 + 14.75} = \frac{44.25}{118.75} = 0.38 \text{ inches}$$

Corrected vertical abscissa of point =  $12 - .38 = 11.62$

Corrected vertical ordinate of point =  $6 - .25 = 5.75$

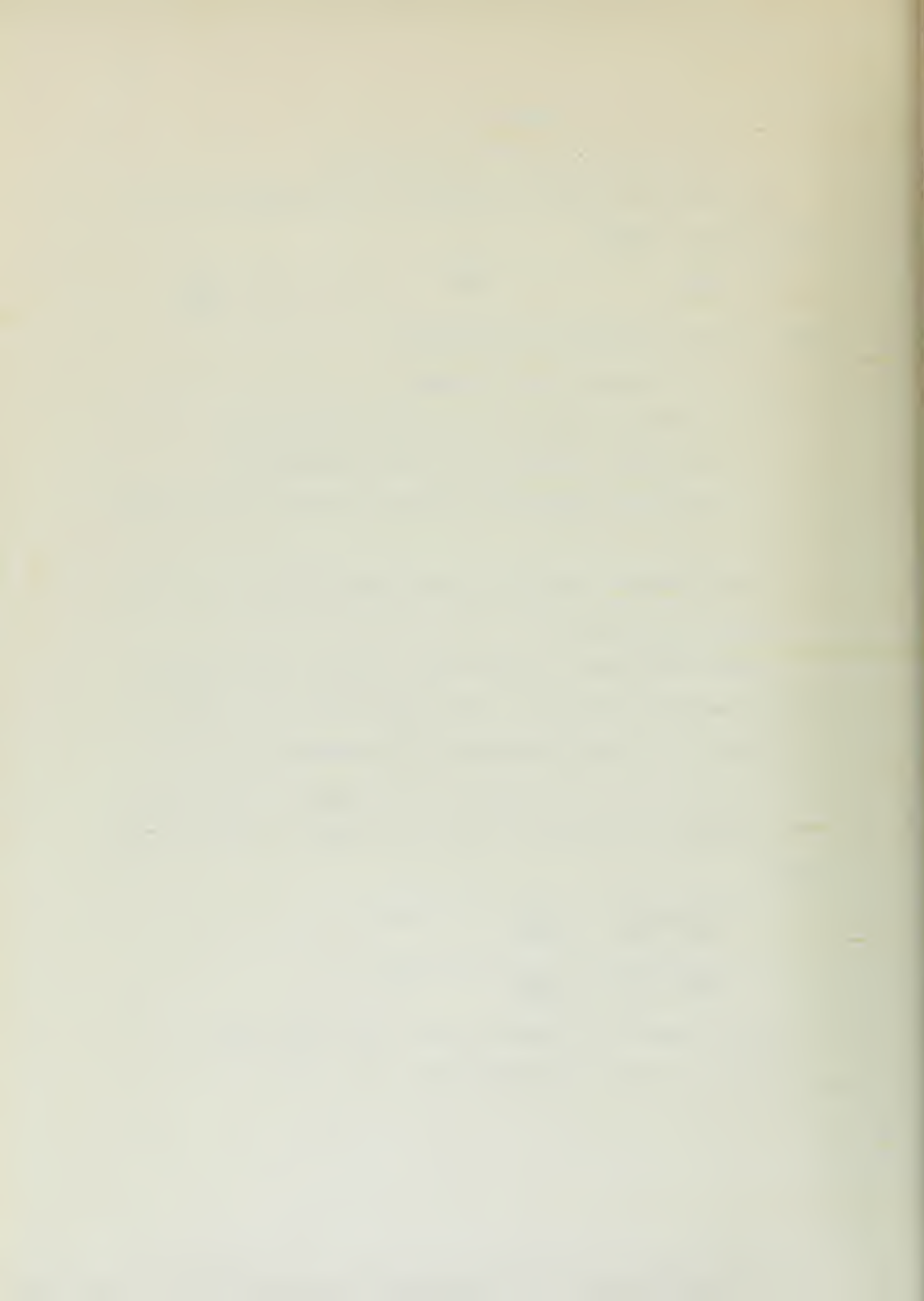

Table 14

## Computation of Analysis of Variance

A factorial design with replication was employed for the analysis of variance. The formulae used and a sample problem are outlined below. The sample data is that of the motion path of transport therblig 1. The steps are listed in the sequence used:

1. Computation of the correction term, C.T.

$$C.T. = \frac{T^2}{kmv}$$

where T is the total of all kmv X's,

X is the individual measurement,

k is the number of columns of cells,

m is the number of rows of cells, and

v is the number of measurements per cell.

$$\text{Example: } C.T. = \frac{(1092.4)^2}{(3)(12)(5)} = \frac{1,193,337.76}{180} = 6629.6542$$

2. Computation of the within-cell variation,  $Q_e$ .

$$Q_e = \text{Total} \sum_1^{kmv} X^2 - \sum_1^{km} \frac{T_s^2}{v}$$

where  $T_s$  is the sum in each of km cells.

$$\begin{aligned} \text{Example: } Q_e &= 6789.76 - \frac{(33,876.54)}{5} \\ &= 6789.76 - 6775.308 = 14.452 \end{aligned}$$

3. Computation of the among-cell variation,  $Q_{c,r}$ .

$$Q_{c,r} = \sum_1^{km} \frac{T_s^2}{v} - \frac{T^2}{kmv}$$

$$\text{Example: } Q_{p,o} = \frac{33,876.54}{5} - \frac{(1092.4)^2}{180} = 145.6538$$



Table 14 (Cont'd)

4. Computation of the column-to-column variation,  $Q_c$ .

$$Q_c = \frac{\sum_1^k T_t^2}{mv} - \frac{T^2}{kmv}$$

where  $T_t$  is the total for each of the  $k$  columns.

$$\begin{aligned} \text{Example: } Q_p &= \frac{(352.0)^2 + (360.2)^2 + (380.2)^2}{(12)(5)} - \frac{(1092.4)^2}{(3)(12)(5)} \\ &= 6636.6680 - 6629.6542 = 7.0138 \end{aligned}$$

5. Computation of the row-to-row variation,  $Q_r$ .

$$Q_r = \frac{\sum_1^m S_j^2}{kv} - \frac{T^2}{kmv}$$

where  $S_j$  is the sum for each of the  $r$  rows.

$$\begin{aligned} \text{Example: } Q_o &= \frac{101,039.5995}{(3)(5)} - \frac{(1092.4)^2}{(3)(12)(5)} \\ &= 6735.9733 - 6629.6542 = 106.3191 \end{aligned}$$

6. Computation of interaction variation,  $Q_{cxr}$ .

$$Q_{cxr} = Q_{c,r} - Q_c - Q_o$$

$$\begin{aligned} \text{Example: } Q_{pxo} &= Q_{p,o} - Q_p - Q_o \\ &= 145.6538 - 7.0138 - 106.3191 = 32.3209 \end{aligned}$$

7. Computation of the degrees of freedom.

$$Q_e : km(v-1)$$

$$\text{Example: } Q_e : (3)(12)(5-1) = 144$$

$$Q_c : k - 1$$

$$\text{Example: } Q_c : 3 - 1 = 2$$



Table 14 (Cont'd)

$$Q_r : m - 1$$

$$\text{Example: } Q_o : 12 - 1 = 11$$

$$Q_{cXR} : km - k - m + 1$$

$$\text{Example: } Q_{pXO} : (3)(12) - 3 - 12 + 1 = 22$$

8. Computation of the mean square values for the sources of variation.

The mean square values were obtained by determining the ratio between the source variation and its degrees of freedom.

Example: mean square value for operator source of

$$\text{variation} = \frac{106.3191}{11} = 9.6654$$

9. Computation of the  $F_c$  values for the sources of variation.

The  $F_c$  values for the sources of variation were obtained by determining the ratio between the mean square of the source of variation and the mean square of the error term.

$$\text{Example: operator } F_c \text{ value} = \frac{9.6654}{0.1004} = 96.27$$

10. Comparison of the computed F values with tabulated F values.

The F values were obtained from Snedecor<sup>19</sup>. To locate the appropriate F value the table was entered with the degrees of freedom of the source of variation and the degrees of freedom of the error term. Table 15 shows the comparison of the computed F values with the tabulated F values.

---

<sup>19</sup>Snedecor, G.W., (op. cit.), Table 10.2, pp. 184-187.



## Table 14 (Cont'd)

Example: operator computed F value = 96.27

tabulated value for 11 and 144 degrees of freedom  
for significance at the 1% level = 2.38.

Therefore, the operator source of variation is  
significant because its  $F_c$  value exceeds the tabu-  
lated F value.



Table 15

## Intermediate Data of Analysis of Variance

Cell Totals for Three Phases

Operator	Path 1	Path 2	Path 3	Path 4	Path 5	Path 6
1	72.7	101.3	85.9	81.7	110.2	79.2
2	101.2	121.1	123.1	110.6	124.0	109.9
3	90.3	104.5	104.4	97.6	109.5	96.5
4	92.3	106.1	98.7	96.0	107.6	89.6
5	79.3	105.6	91.2	91.0	107.1	81.3
6	99.2	115.1	108.0	104.6	113.8	100.3
7	96.1	125.0	122.0	112.6	119.4	101.7
8	90.7	111.3	105.5	97.1	108.8	87.6
9	80.4	102.9	84.5	89.2	104.2	73.4
10	86.8	113.7	97.1	101.2	108.6	87.8
11	84.9	107.3	91.0	92.4	109.8	78.6
12	118.5	122.2	120.4	114.1	122.2	111.3

Cell Totals for All Operators

Phase	Path 1	Path 2	Path 3	Path 4	Path 5	Path 6
A	352.0	436.7	403.7	386.0	457.3	361.8
B	360.2	450.3	408.6	394.9	440.1	360.1
C	380.2	449.1	419.5	407.2	447.8	375.3

	Path 1	Path 2	Path 3
Total $\Sigma X$	1092.4	1336.1	1231.8
Total $\Sigma X^2$	6789.76	9998.73	8621.42
C.T.	6629.6542	9917.5734	8429.618
$Q_e$	14.4520	12.9120	16.4080
$Q_{p,o}$	145.6538	68.2446	175.3940
$Q_p$	7.0138	1.8898	2.1803
$Q_o$	106.3191	47.6699	138.0473
$Q_{pxo}$	32.3209	18.6849	35.1664
	Path 4	Path 5	Path 6
Total $\Sigma X$	1188.1	1345.2	1097.2
Total $\Sigma X^2$	7986.45	10107.52	6840.08
C.T.	7842.1201	10053.1280	6688.0436
$Q_e$	17.2200	10.9760	12.2360
$Q_{p,o}$	127.1099	43.4160	139.8004
$Q_p$	3.7774	2.4743	2.3121
$Q_o$	73.4126	29.7507	114.5924
$Q_{pxo}$	49.9199	11.1910	22.8959

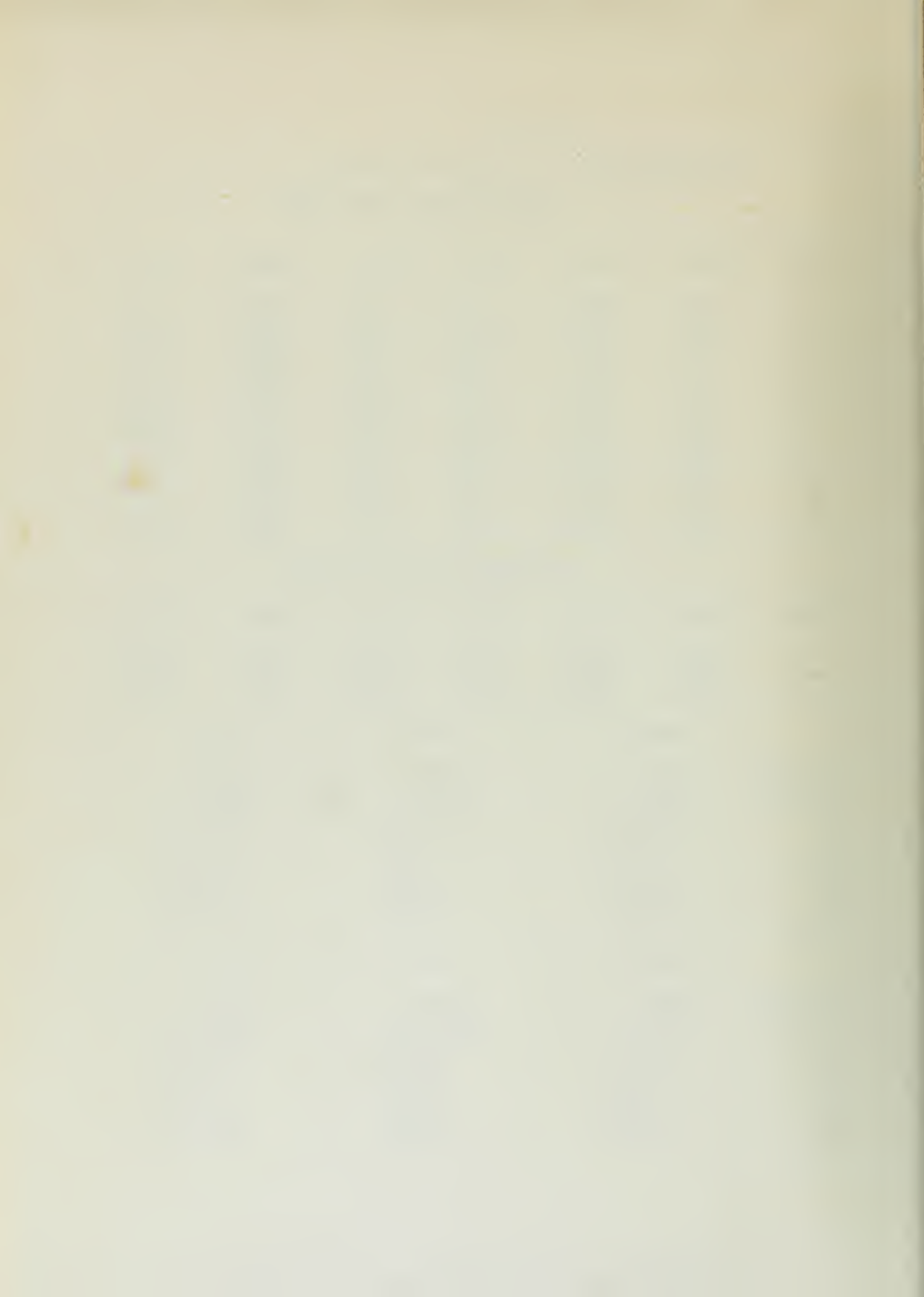

Table 15 (Cont'd)

Source of Variation	Degrees of Freedom	<u>Analysis</u>		
		Path 1	Path 2	Path 3
Perform. Rate	2	3.5069	0.9449	1.09015
Operator	11	9.6654	4.3336	12.5498
O x P	22	1.4691	0.8493	1.5985
Error	144	0.1004	0.0897	0.1139
		Path 4	Path 5	Path 6
Perform. Rate	2	1.8887	1.23715	1.15605
Operator	11	6.6739	2.7046	10.4175
O x P	22	2.2691	0.5087	1.0407
Error	144	0.1196	0.0762	0.0850



Table 16

## Comparison of F Values

Path	Performance Rate		Operator		Performance Rate x Operator	
	$F_c$	$F_t$	$F_c$	$F_t$	$F_c$	$F_t$
1	34.93	4.76	96.27	2.38	14.63	1.96
2	10.53	4.76	48.31	2.38	9.47	1.96
3	9.57	4.76	110.18	2.38	14.03	1.96
4	15.79	4.76	55.80	2.38	18.97	1.96
5	16.24	4.76	35.49	2.38	6.68	1.96
6	13.60	4.76	122.56	2.38	12.24	1.96

$F_c$  is the calculated value of F ratio.

$F_t$  is the value from tabulated 1% points for the distribution of F.

Inspection of the above data reveals that the  $F_c$  value exceeds the  $F_t$  value in every case; therefore the three sources of variation listed can be considered to be significant variables.



Table 17

## Computation of Components of Variation

The mean square values for the sources of variation as obtained by the analysis of variance are listed in Table 15. The expected mean squares for the sources of variation are listed below:

<u>Source of Variation</u>	<u>Expected Mean Squares</u>
Operators	$\sigma_e^2 + 5 \frac{(K-k)}{(K)} \sigma_I^2 + 5k \sigma_o^2$
Performance Rate	$\sigma_e^2 + 5 \frac{(M-m)}{(M)} \sigma_I^2 + 5m \sigma_p^2$
O x P Interaction	$\sigma_e^2 + 5 \sigma_I^2$
Error	$\sigma_e^2$

Where  $\sigma_e^2$  is the variation due to error,

$\sigma_I^2$  is the variation due to the interaction,

$\sigma_p^2$  is the variation due to the performance rates,

$\sigma_o^2$  is the variation due to the operators,

$m$  is the number of performance rates,

$M$  is the total population of setups,

$k$  is the number of operators, and

$K$  is the total population of operators.

Treating this experiment as a fixed model:

$$m = M = 3$$

$$k = K = 12$$

$$\frac{(M-m)}{(M)} = 0$$

$$\frac{(K-k)}{(K)} = 0$$

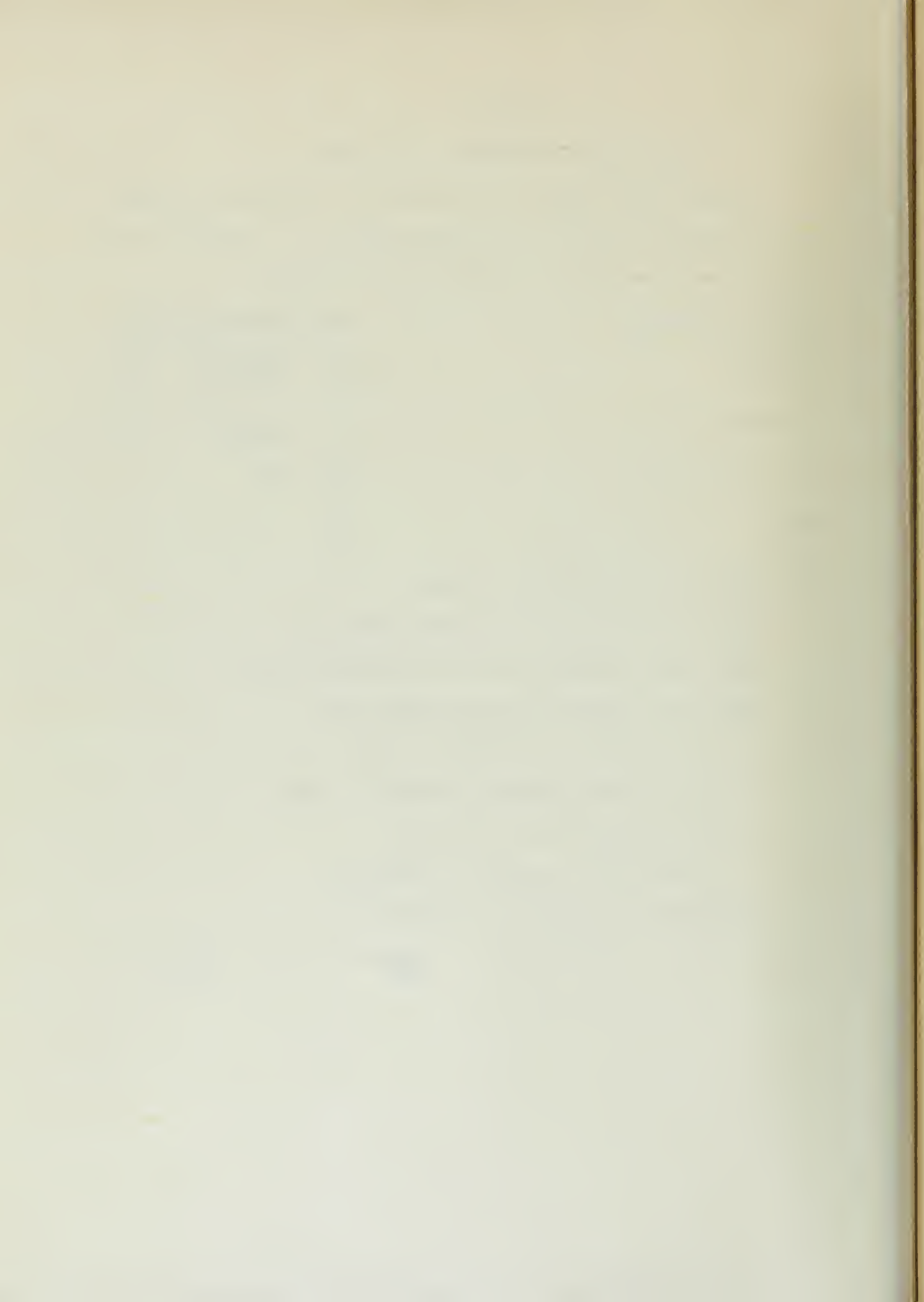

Table 17 (Cont'd)

Using data for motion path 1 as listed in Table 15, a sample problem is worked below:

$$\sigma_e^2 = 0.1004$$

$$\sigma_e^2 + 5\sigma_I^2 = 1.4691$$

$$\sigma_I^2 = \frac{1.4691 - 0.1004}{5} = 0.2737$$

$$\sigma_e^2 = 15\sigma_o^2 = 9.6654$$

$$\sigma_o^2 = \frac{9.6654 - 0.1004}{15} = 0.6737$$

$$\sigma_e^2 = 60\sigma_p^2 = 3.5069$$

$$\sigma_p^2 = \frac{3.5069 - 0.1004}{60} = 0.0568$$

$$\text{Total Variation} = \sigma_e^2 + \sigma_I^2 + \sigma_p^2 + \sigma_o^2 =$$

$$= 0.1004 + 0.2737 + 0.6377 + 0.0568 = 1.0686$$

The percentage of the total variation which could be attributed to a particular source of variation was determined by dividing the component of variation by the total variation:

$$\% \text{ of variation due to error} = \frac{0.1004}{1.0686} = 9.4\%$$

$$\% \text{ of variation due to O x P interaction} = \frac{0.2737}{1.0686} = 25.6\%$$

$$\% \text{ of variation due to operators} = \frac{0.6377}{1.0686} = 59.7\%$$

$$\% \text{ of variation due to performance rate} = \frac{0.0568}{1.0686} = 5.3\%$$

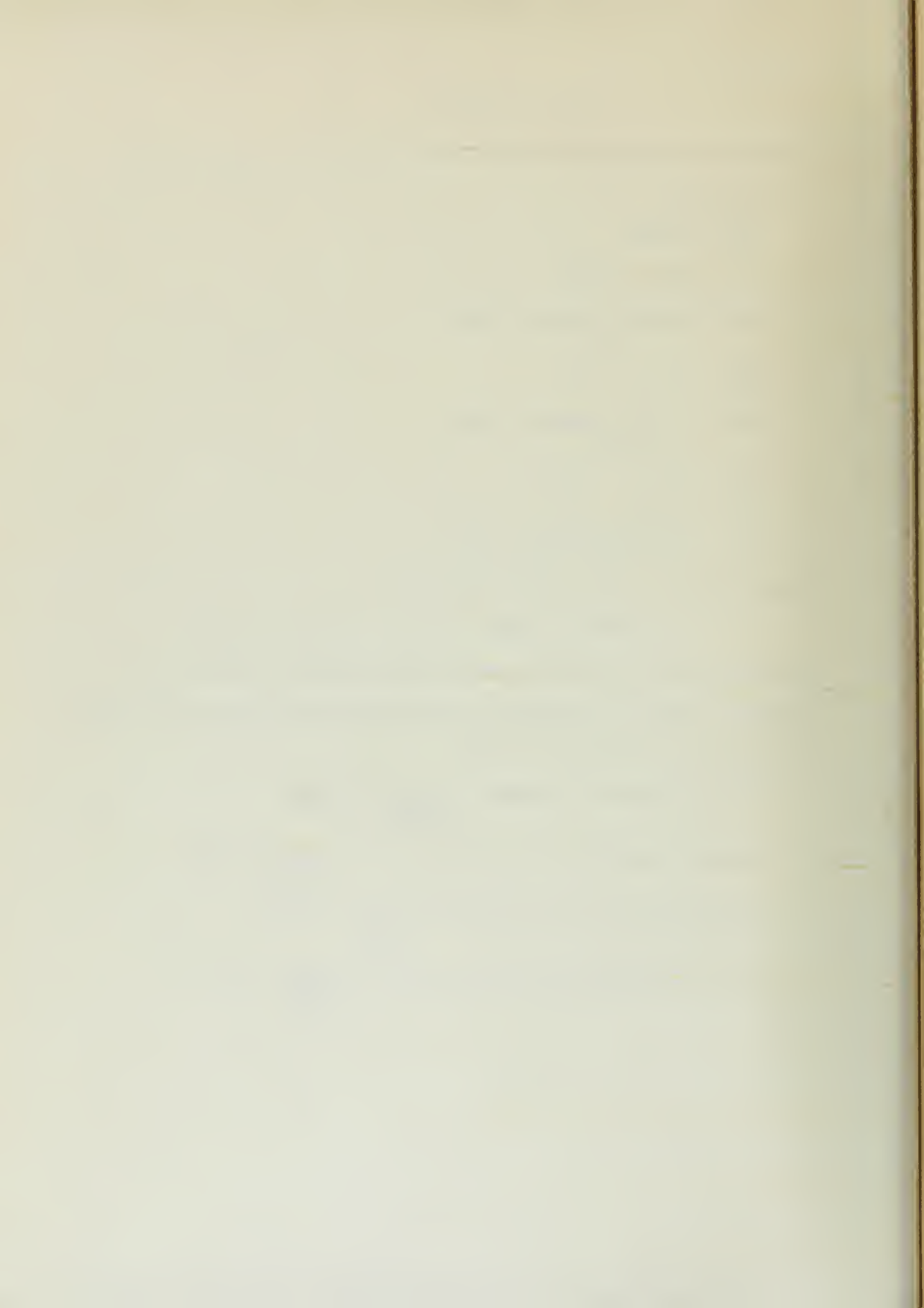

Table 18  
Components of Variation

	<u>Motion Paths</u>					
	Path 1	Path 2	Path 3	Path 4	Path 5	Path 6
$\sigma_e^2$	.1004	.0897	.1139	.1196	.0762	.0850
$\sigma_I^2$	.2737	.1519	.2969	.4299	.1017	.2081
$\sigma_o^2$	.6377	.2829	.8291	.4369	.1803	.6945
$\sigma_p^2$	.0568	.0142	.0163	.0295	.0206	.0193
$\sigma_T^2$	1.0686	.5387	1.2562	1.0159	.3788	1.0069
$\% \sigma_e^2$	9.4	16.7	9.1	11.8	20.1	8.5
$\% \sigma_I^2$	25.6	28.1	23.6	42.3	26.8	20.7
$\% \sigma_o^2$	59.7	52.6	66.0	43.0	47.6	68.9
$\% \sigma_p^2$	5.3	2.6	1.3	2.9	5.5	1.9
$\% \sigma_T^2$	100.0	100.0	100.0	100.0	100.0	100.0

$\sigma_e^2$  is the variation due to error.

$\sigma_I^2$  is the variation due to the interaction.

$\sigma_o^2$  is the variation due to the operators.

$\sigma_p^2$  is the variation due to the performance rates.

$\sigma_T^2$  is the total variation.

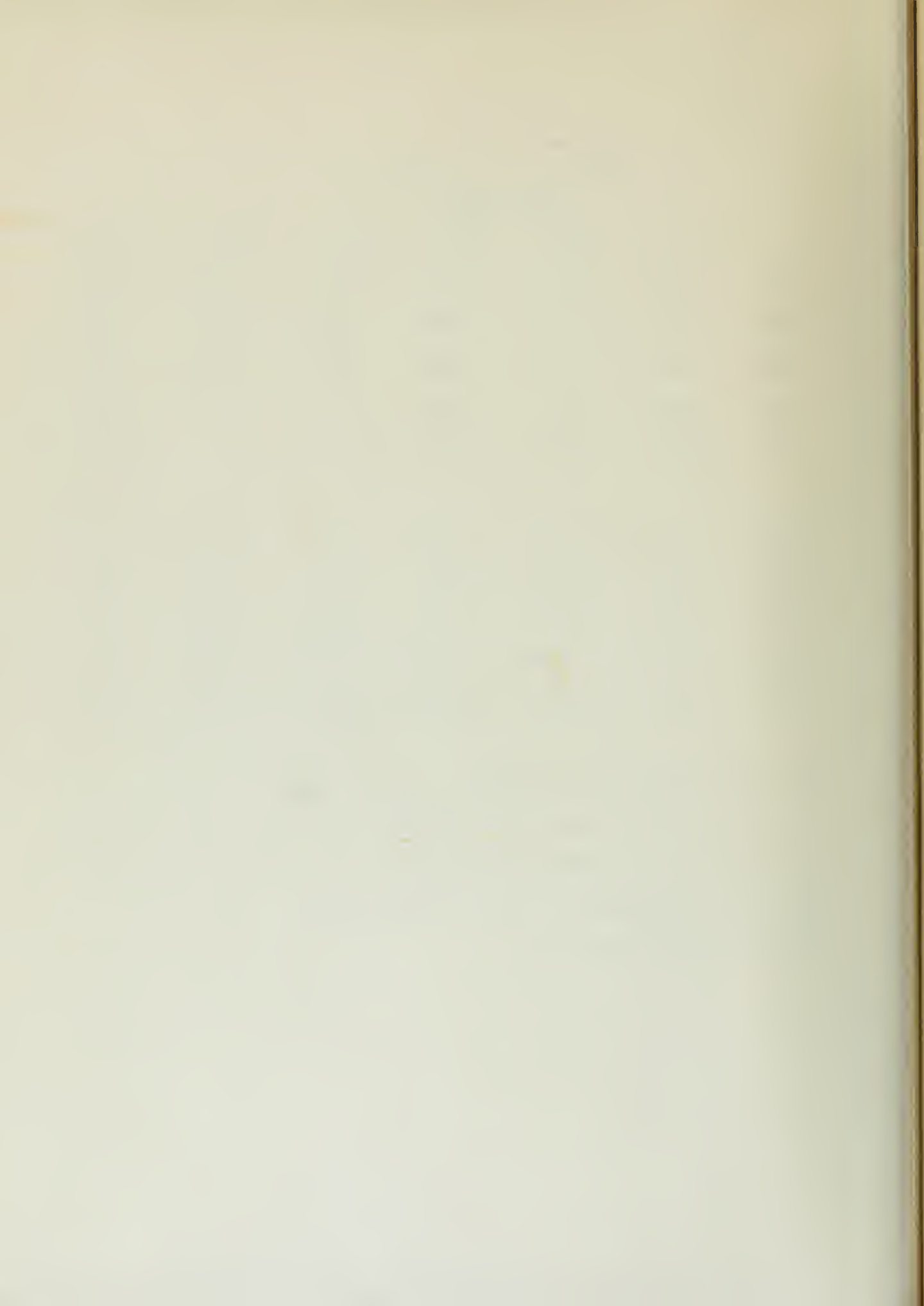

Table 19

## Computation of Multiple Comparison of Means

To make the multiple comparison of means it was necessary to check the  $\theta$  confidence intervals which are:

$$\theta \pm q(k, N-k) \sqrt{\frac{\sigma_e^2}{n}}$$

where  $\theta$  is the difference of the means being compared,

$q$  is the Studentized range,

$k$  is the number of means in the experiment,

$N$  is the total number of measurements in the experiment,

$n$  is the number of measurements used in computing a single mean, and

$\sigma_e^2$  is the variation due to error.

In this experiment:

$$k = 3 \qquad N = 180 \qquad N-k = 177 \qquad n = 60$$

To determine  $q$ , the Studentized range, the table<sup>20</sup> was entered with the values of  $k$  and  $N-k$ . The value of  $q(3, 177)$  was found to be 4.20 for the 99% confidence level and 3.36 for the 95% confidence level.

If  $\theta \pm q(k, N-k) \sqrt{\frac{\sigma_e^2}{n}}$  does not overlap zero, a significant difference exists between the means being compared. Computations of the  $\theta$  confidence intervals of the data for motion path 1 was carried out as indicated below:

$$\theta_1 = \bar{X}_A - \bar{X}_B = -0.13$$

$$\sigma_e^2 = 0.1004$$

$$\theta_2 = \bar{X}_A - \bar{X}_C = -0.47$$

$$n = 60$$

$$\theta_3 = \bar{X}_B - \bar{X}_C = -0.34$$

$$q(3, 177) = 4.20 \text{ (99\% level)}$$

<sup>20</sup>Dixon, W.J. and Massey, F.J., Introduction to Statistical Analysis, McGraw-Hill, New York, 1951, table 18, pp. 342-343.

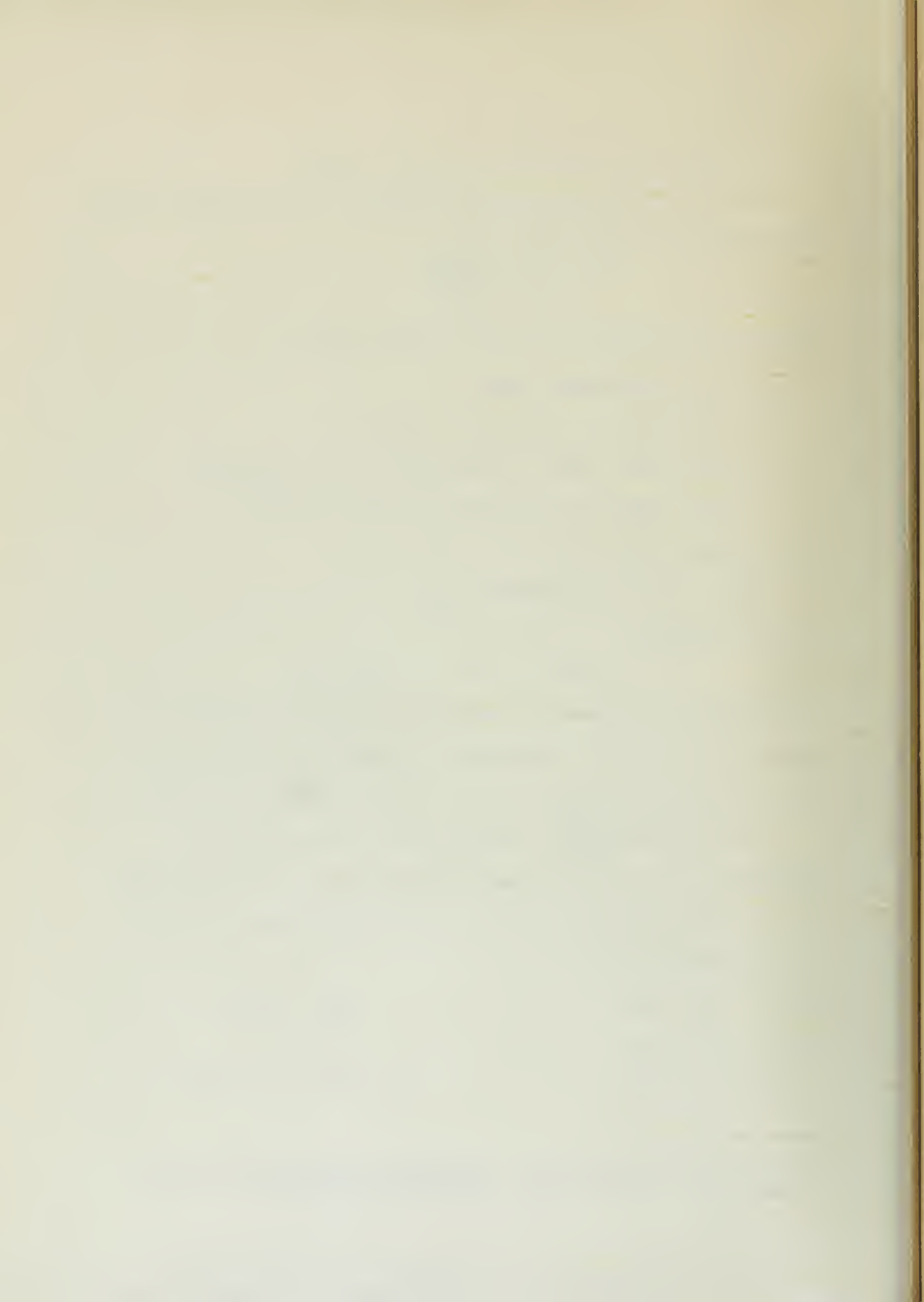

Table 19 (Cont'd)

$$A \text{ vs } B: -0.13 \pm 4.20 \sqrt{\frac{0.1004}{60}} = -0.13 \pm 0.17$$

$$A \text{ vs } C: -0.47 \pm 4.20 \sqrt{\frac{0.1004}{60}} = -0.47 \pm 0.17$$

$$B \text{ vs } C: -0.34 \pm 4.20 \sqrt{\frac{0.1004}{60}} = -0.34 \pm 0.17$$

Since the  $\theta$  confidence intervals of A vs C and B vs C did not overlap zero, it can be stated that a significant difference exists between the means of A and C and the means of B and C.

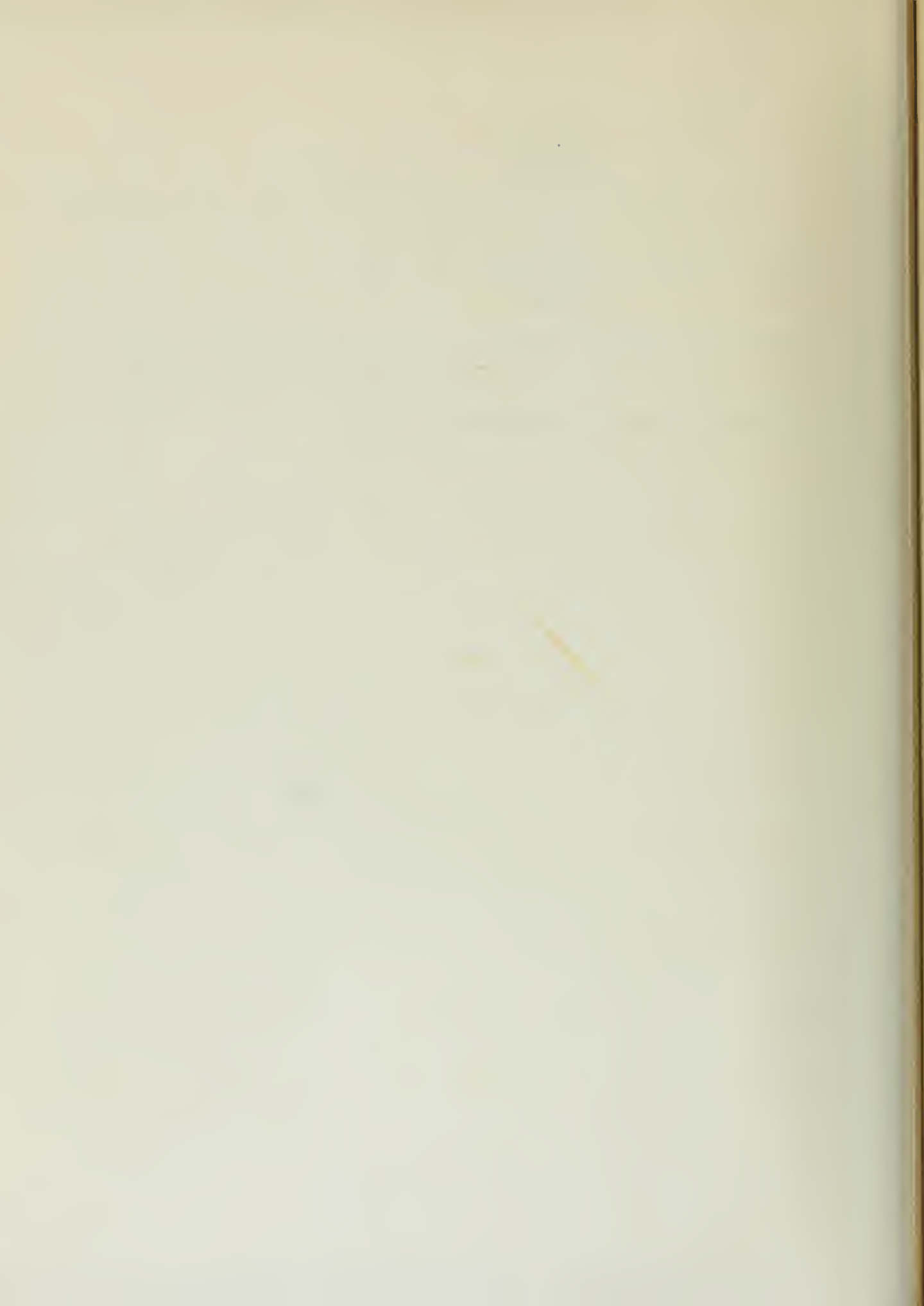

Table 20

## Multiple Comparison of Means Intermediate Data

<u><math>\bar{X}</math> for all Operators</u>						
Phase	Path 1	Path 2	Path 3	Path 4	Path 5	Path 6
A	5.87	7.28	6.73	6.43	7.62	6.03
B	6.00	7.50	6.81	6.58	7.34	6.00
C	6.34	7.48	6.99	6.79	7.46	6.26
<u>Differences of Means</u>						
$\theta_1$	-0.13	-0.22	-0.08	-0.15	+0.28	+0.03
$\theta_2$	-0.47	-0.20	-0.26	-0.36	+0.16	-0.23
$\theta_3$	-0.34	+0.02	-0.18	-0.21	-0.12	-0.26
<u>Variation Due to Error</u>						
$\sigma_e^2$	0.1004	0.0897	0.1139	0.1196	0.0762	0.0850

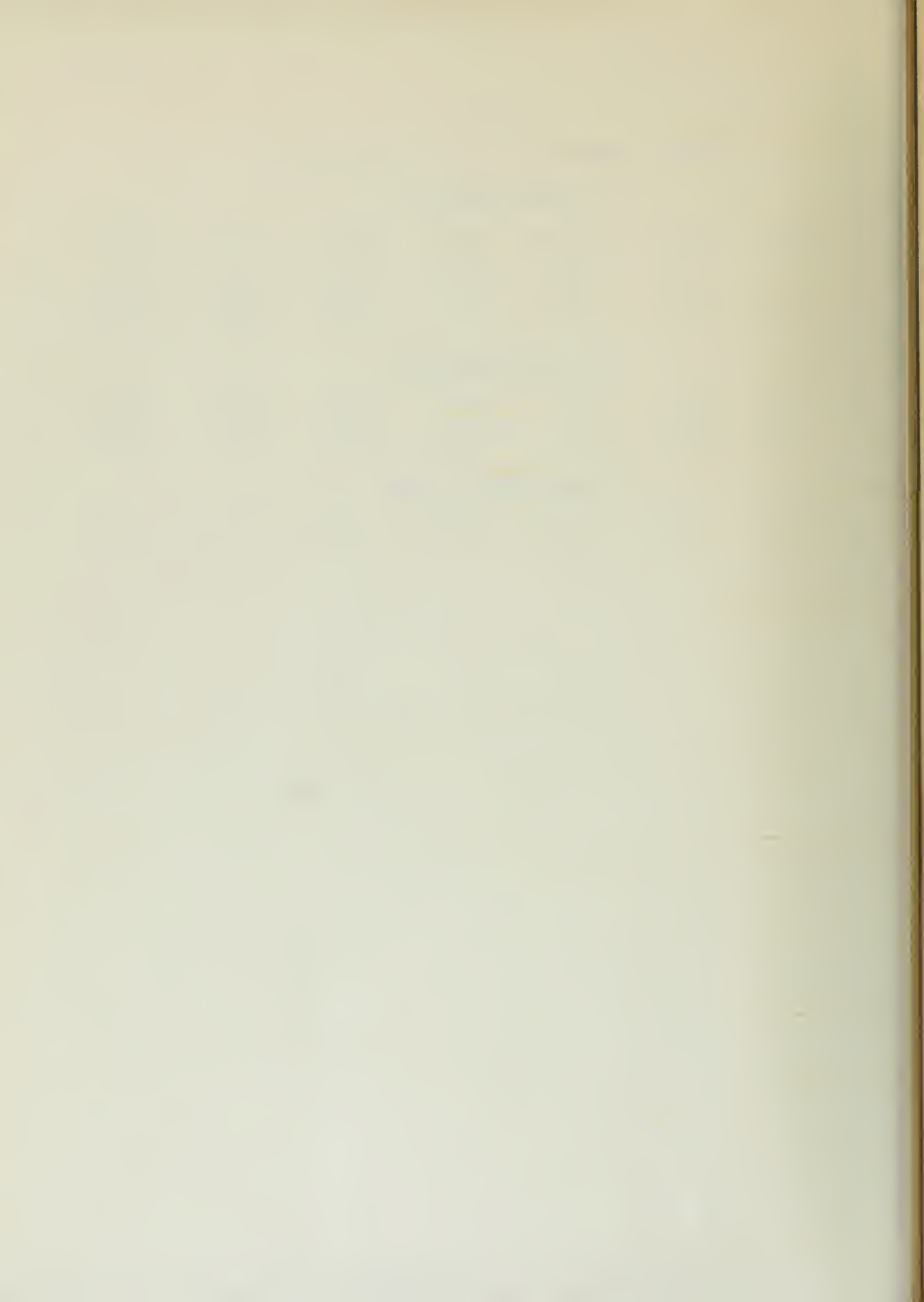

Table 21

## Results of Multiple Comparison of Means

Path	Means	Confidence Interval (99%)	Overlap Zero
1	A:B	$-0.13 \pm 0.17$	Yes
	A:C	$-0.47 \pm 0.17$	No
	B:C	$-0.34 \pm 0.17$	No
2	A:B	$-0.22 \pm 0.16$	No
	A:C	$-0.20 \pm 0.16$	No
	B:C	$+0.02 \pm 0.16$	Yes
3	A:B	$-0.08 \pm 0.18$	Yes
	A:C	$-0.26 \pm 0.18$	No
	B:C	$-0.18 \pm 0.18$	No
4	A:B	$-0.15 \pm 0.19$	Yes
	A:C	$-0.36 \pm 0.19$	No
	B:C	$-0.21 \pm 0.19$	No
5	A:B	$+0.28 \pm 0.15$	No
	A:C	$+0.16 \pm 0.15$	No
	B:C	$-0.12 \pm 0.15$	Yes
6	A:B	$+0.03 \pm 0.16$	Yes
	A:C	$-0.23 \pm 0.16$	No
	B:C	$-0.26 \pm 0.16$	No

Rank Order of the Mean Values

Phase	Path 1	Path 2	Path 3	Path 4	Path 5	Path 6
A	1½	1	1½	1½	1	1½
B	1½	2½	1½	1½	2½	1½
C	3	2½	3	3	2½	3

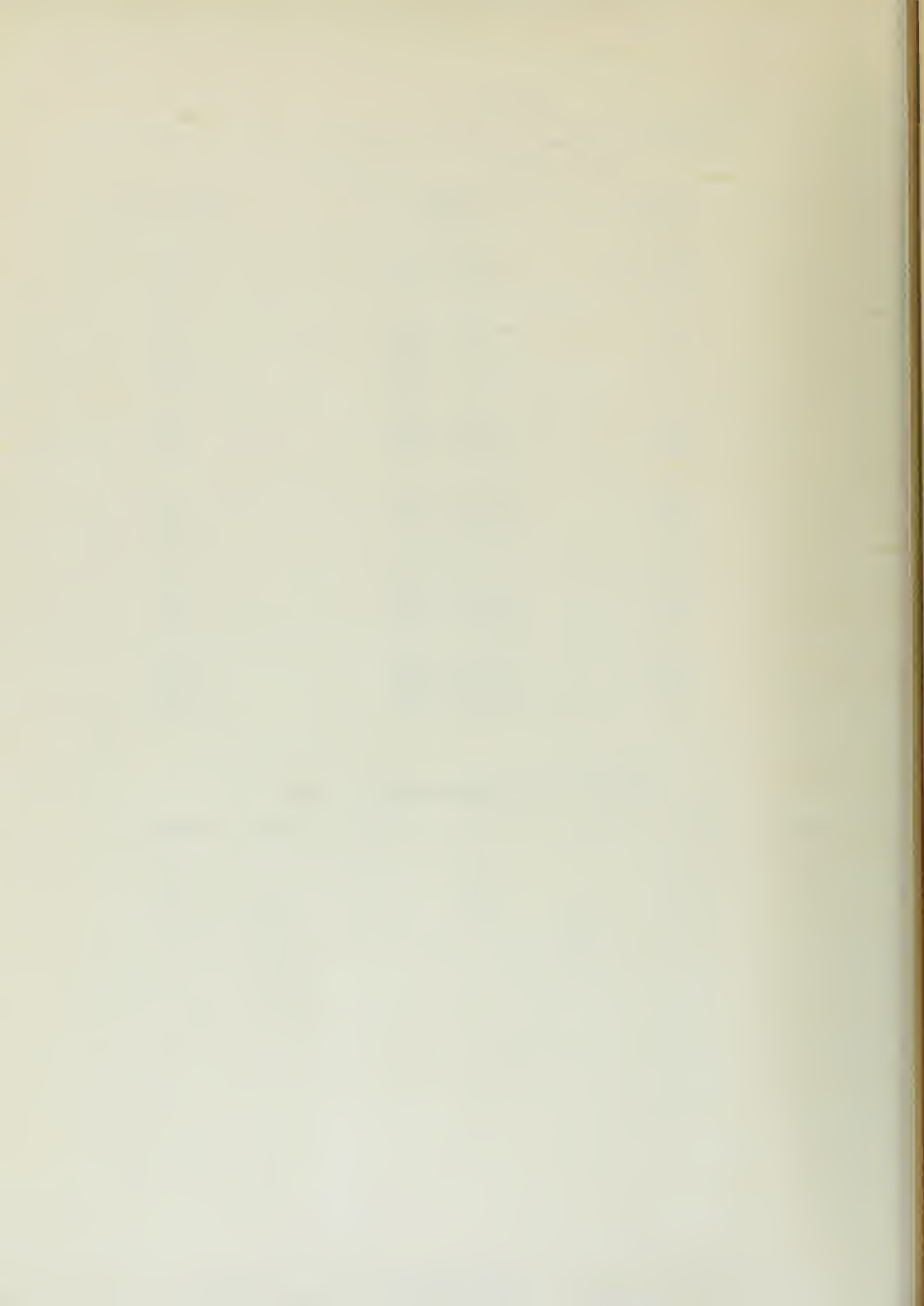

## BIBLIOGRAPHY

Alford, L.P. and Bangs, J.R., Production Handbook, Ronald Press Company, New York, 1947.

Barnes, R.M. and Mundel, M.E., "A Study of Hand Motions Using the Photoelectric Cell and the Kymograph," University of Iowa Studies in Engineering, Bulletin 12.

Dixon, W.J. and Massey, F.J., Introduction to Statistical Analysis, McGraw-Hill, New York, 1951.

Gilbreth, F.B. and L.M., Applied Motion Study, Sturgis & Walton Company, New York, 1919.

Holmes, W.G., Applied Time and Motion Study, Ronald Press Company, New York, 1938.

Mundel, M.E., Motion and Time Study, Prentice-Hall, Inc., New York, 1950.

Rice, J.M., "Theoretical Mechanics," Handbook of Engineering Fundamentals, John Wiley & Sons, Inc., New York, 1949.

Sampter, H.C., Motion Study, Pitman Publishing Company, New York, 1941.

Smalley, H.C., "An Evaluation of Two Methods of Measuring Work Motion Paths," M.S. Thesis, Purdue University, August, 1947.

Snedecor, G.W., Statistical Methods, Collegiate Press, Ames, 1937.

Tukey, J.W., "Comparing Individual Means in the Analysis of Variance," Biometrika 5, 1949.







NOV 10

DISPLAY

Thesis  
C483

Clark

25015

An investigation of the  
effect of minute motion  
path variations upon oper-  
ator performance.

NOV 10

DISPLAY

015

the  
n

25015

Thesis  
C483

Clark

An investigation of the effect  
of minute motion path variations  
upon operator performance.

thesC483

An investigation of the effect of minute

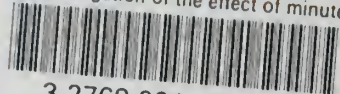

3 2768 001 02608 1

DUDLEY KNOX LIBRARY