



BEHAVIOR/APPLICATION OF SUPERCAPACITORS INTEGRATED WITH A SHIP'S POWER MANAGEMENT SYSTEM DURING VARYING LOAD CONDITIONS

Title	BEHAVIOR/APPLICATION OF SUPERCAPACITORS INTEGRATED WITH A SHIP'S POWER MANAGEMENT SYSTEM DURING VARYING LOAD CONDITIONS
Item Type	Thesis
Authors	Ralson, Kevin
URI	https://hdl.handle.net/10945/62772
Publisher	Monterey, CA; Naval Postgraduate School
Date Issued	2019-06
Rights	This publication is a work of the U.S. Government as defined in Title 17, United States Code, Section 101. Copyright protection is not available for this work in the United States.
Download date	2026-04-13 20:13:24
Link to Item	https://hdl.handle.net/10945/62772

Downloaded from NPS Archive: Calhoun



NAVAL POSTGRADUATE SCHOOL

MONTEREY, CALIFORNIA

THESIS

**BEHAVIOR/APPLICATION OF SUPERCAPACITORS
INTEGRATED WITH A SHIP'S POWER MANAGEMENT
SYSTEM DURING VARYING LOAD CONDITIONS**

by

Kevin Ralson

June 2019

Thesis Advisor:
Co-Advisor:

Giovanna Oriti
Roberto Cristi

Approved for public release. Distribution is unlimited.

THIS PAGE INTENTIONALLY LEFT BLANK

REPORT DOCUMENTATION PAGE			<i>Form Approved OMB No. 0704-0188</i>
Public reporting burden for this collection of information is estimated to average 1 hour per response, including the time for reviewing instruction, searching existing data sources, gathering and maintaining the data needed, and completing and reviewing the collection of information. Send comments regarding this burden estimate or any other aspect of this collection of information, including suggestions for reducing this burden, to Washington headquarters Services, Directorate for Information Operations and Reports, 1215 Jefferson Davis Highway, Suite 1204, Arlington, VA 22202-4302, and to the Office of Management and Budget, Paperwork Reduction Project (0704-0188) Washington, DC 20503.			
1. AGENCY USE ONLY (Leave blank)	2. REPORT DATE June 2019	3. REPORT TYPE AND DATES COVERED Master's thesis	
4. TITLE AND SUBTITLE BEHAVIOR/APPLICATION OF SUPERCAPACITORS INTEGRATED WITH A SHIP'S POWER MANAGEMENT SYSTEM DURING VARYING LOAD CONDITIONS			5. FUNDING NUMBERS
6. AUTHOR(S) Kevin Ralson			
7. PERFORMING ORGANIZATION NAME(S) AND ADDRESS(ES) Naval Postgraduate School Monterey, CA 93943-5000			8. PERFORMING ORGANIZATION REPORT NUMBER
9. SPONSORING / MONITORING AGENCY NAME(S) AND ADDRESS(ES) N/A			10. SPONSORING / MONITORING AGENCY REPORT NUMBER
11. SUPPLEMENTARY NOTES The views expressed in this thesis are those of the author and do not reflect the official policy or position of the Department of Defense or the U.S. Government.			
12a. DISTRIBUTION / AVAILABILITY STATEMENT Approved for public release. Distribution is unlimited.			12b. DISTRIBUTION CODE A
13. ABSTRACT (maximum 200 words) <p>The goal of this research is to study the implementation of supercapacitors (SCs) into the energy storage system of an electric propulsion system (EPS) on a hybrid-powered vessel. A commercial ship EPS can be designed in a similar fashion as the drive system of a hybrid vehicle. The first commercial hybrid vessels are just now coming online, with a traditional hybrid propulsion system (HPS) consisting of only a battery bank and diesel-electric propulsion. This study looks at adding a bank of supercapacitors to work with the EPS.</p> <p>The addition of supercapacitors to an HPS is advantageous in many ways. SCs can be discharged thousands of times more than a high energy density battery, thus extending the life of the SC bank. One unique characteristic of SCs is their ability to discharge a large amount of energy very quickly, making this trait very useful for vessel operations—for example, during the power take-off and the starting of heavy electrical machinery, which draws an enormous load during the first seconds of start-up. However, the main focus of this study is the EPS during normal sea conditions where a vessel will spend the majority of its lifetime.</p> <p>Computer simulations (using MATLAB and Simulink) confirmed that, with the appropriate control and management, SCs reduce the strain on batteries. Also, the fuel efficiency was shown to be improved when comparing a hybrid propulsion system to a non-hybrid propulsion system.</p>			
14. SUBJECT TERMS hybrid ship, batteries, DC power, supercapacitor, energy management system			15. NUMBER OF PAGES 73
			16. PRICE CODE
17. SECURITY CLASSIFICATION OF REPORT Unclassified	18. SECURITY CLASSIFICATION OF THIS PAGE Unclassified	19. SECURITY CLASSIFICATION OF ABSTRACT Unclassified	20. LIMITATION OF ABSTRACT UU

THIS PAGE INTENTIONALLY LEFT BLANK

Approved for public release. Distribution is unlimited.

**BEHAVIOR/APPLICATION OF SUPERCAPACITORS INTEGRATED WITH A
SHIP'S POWER MANAGEMENT SYSTEM DURING VARYING LOAD
CONDITIONS**

Kevin Ralson
Lieutenant, United States Coast Guard
BS, Texas A & M University, 2008

Submitted in partial fulfillment of the
requirements for the degree of

**MASTER OF SCIENCE IN ENGINEERING SCIENCE
(ELECTRICAL ENGINEERING)**

from the

**NAVAL POSTGRADUATE SCHOOL
June 2019**

Approved by: Giovanna Oriti
Advisor

Roberto Cristi
Co-Advisor

Douglas J. Fouts
Chair, Department of Electrical and Computer Engineering

THIS PAGE INTENTIONALLY LEFT BLANK

ABSTRACT

The goal of this research is to study the implementation of supercapacitors (SCs) into the energy storage system of an electric propulsion system (EPS) on a hybrid-powered vessel. A commercial ship EPS can be designed in a similar fashion as the drive system of a hybrid vehicle. The first commercial hybrid vessels are just now coming online, with a traditional hybrid propulsion system (HPS) consisting of only a battery bank and diesel-electric propulsion. This study looks at adding a bank of supercapacitors to work with the EPS.

The addition of supercapacitors to an HPS is advantageous in many ways. SCs can be discharged thousands of times more than a high energy density battery, thus extending the life of the SC bank. One unique characteristic of SCs is their ability to discharge a large amount of energy very quickly, making this trait very useful for vessel operations—for example, during the power take-off and the starting of heavy electrical machinery, which draws an enormous load during the first seconds of start-up. However, the main focus of this study is the EPS during normal sea conditions where a vessel will spend the majority of its lifetime.

Computer simulations (using MATLAB and Simulink) confirmed that, with the appropriate control and management, SCs reduce the strain on batteries. Also, the fuel efficiency was shown to be improved when comparing a hybrid propulsion system to a non-hybrid propulsion system.

THIS PAGE INTENTIONALLY LEFT BLANK

TABLE OF CONTENTS

I.	INTRODUCTION.....	1
A.	MOTIVATION	1
B.	PURPOSE AND RELATED WORK.....	2
II.	BACKGROUND	7
A.	BATTERIES.....	7
B.	SUPERCAPACITORS	9
C.	FUEL EFFICIENCY	11
III.	HYBRID SHIP PROPULSION MODEL.....	15
A.	LOAD MODEL	15
B.	ENERGY STORAGE SYSTEM	17
C.	GENERATOR CONTROLLER	18
D.	BUS AND SC VOLTAGE	20
E.	MODEL PARAMETERS	21
IV.	RESULTS AND ANALYSIS	23
A.	NON-HYBRID MODE	23
1.	Light Sea Conditions.....	23
2.	Moderate Sea Conditions	26
3.	Heavy Sea Conditions	28
B.	HYBRID MODE	29
1.	Light Sea Conditions.....	32
2.	Moderate Sea Conditions	34
3.	Heavy Sea Conditions	38
V.	CONCLUSIONS AND FUTURE WORK.....	43
A.	CONCLUSIONS	43
B.	FUTURE WORK	44
	APPENDIX. MATLAB SCRIPTS	47
	LIST OF REFERENCES.....	53
	INITIAL DISTRIBUTION LIST	55

THIS PAGE INTENTIONALLY LEFT BLANK

LIST OF FIGURES

Figure 1.	Vessel <i>Viking Princess</i> . Source: [3].	2
Figure 2.	Power Density vs. Energy Density. Source: [7].	3
Figure 3.	Hybrid Propulsion System Architecture	5
Figure 4.	Ultracapacitors vs. Battery and Conventional Capacitors. Source: [7].	11
Figure 5.	Diesel Engine Fuel Consumption	13
Figure 6.	SIMULINK Implementation of a Hybrid Ship Propulsion System	15
Figure 7.	Load Model	17
Figure 8.	Energy Storage System Model as Implemented in SIMULINK	18
Figure 9.	Generator Controller	19
Figure 10.	Battery State of Charge Subsystem	20
Figure 11.	DC Buss and SC Voltage Subsystem	21
Figure 12.	Non-hybrid Load Currents at 85%	24
Figure 13.	Figure 12 Enhanced	24
Figure 14.	Non-hybrid Fuel Efficiency at 85% Load	25
Figure 15.	Non-hybrid Mode Load Currents at 70%	26
Figure 16.	Non-hybrid Fuel Efficiency at 70% Load	27
Figure 17.	Non-hybrid Mode Load Currents at 50%	28
Figure 18.	Non-hybrid Fuel Efficiency at 50% Load	29
Figure 19.	Hybrid Mode Fuel Efficiency at 90% Generator Power	30
Figure 20.	Light Load Hybrid Currents	32
Figure 21.	Light Load Comparison with SCs (a) and without SCs (b)	33
Figure 22.	Batteries SOC with SCs (a) and without SCs (b) at Light Load	33

Figure 23.	Moderate Load in Hybrid Mode: Load and Generators' Currents	34
Figure 24.	Moderate Load Hybrid Use of SCs Comparison	35
Figure 25.	Moderate Load Batteries SOC with (a) and without SCs (b)	35
Figure 26.	Moderate Load and Generators at 70% Power	36
Figure 27.	Moderate Load at 70% Hybrid Power SC use Comparison	37
Figure 28.	Battery SOC Comparison at 70% Load on the Generators with SCs (a) and without SCs (b).....	37
Figure 29.	Heavy Sea Hybrid Currents at 90% of the Generators' Power.....	38
Figure 30.	Heavy Sea Hybrid Currents at 50% of the Generators' Power.....	39
Figure 31.	Heavy Seas with One Generator Operation SC Comparison.....	40
Figure 32.	Heavy Load SOC Comparison of SC Use on One Generator	41

LIST OF TABLES

Table 1.	Diesel Engine Fuel Consumption per Hour. Adapted from [5].	12
Table 2.	Hybrid Model Parameters	21
Table 3.	Fuel Efficiency and Fuel Consumption at Each Sea Condition in Hybrid and Non-hybrid Mode	31
Table 4.	Current Peaks of the Batteries and SCs with and without SCs	31

THIS PAGE INTENTIONALLY LEFT BLANK

LIST OF ACRONYMS AND ABBREVIATIONS

Ah	amp hours
ESS	energy storage system
Li-ion	lithium-ion
PI	proportional integral
RPM	rounds per minute
SC	supercapacitor
SOC	state of charge

THIS PAGE INTENTIONALLY LEFT BLANK

ACKNOWLEDGMENTS

The first acknowledgement goes to God and my family. They helped me by allowing me to have the belief, time, and drive to complete my work. The love of my wife, Cecilia, and the support of my daughters, Lilliana and Elizabeth, helped me to remember why I was working so hard. Without their unwavering belief in my abilities this thesis may not have been possible.

Next, I would like to thank all of the teachers, professors, and staff who helped me through my journey at NPS. Especially my advisor, Dr. Giovanna Oriti, and my co-advisor, Dr. Roberto Cristi. They provided me with the knowledge to complete my studies. They were also encouraging in their guidance and very patient.

I would also like to acknowledge the incredible support from my parents. My mom and dad always believed in me no matter what. They raised me to be fair and forgiving with unconditional love. They also provided me with the know-how to be successful and excel in life.

THIS PAGE INTENTIONALLY LEFT BLANK

I. INTRODUCTION

This chapter introduces the reasons for conducting this research through a brief explanation of some assumptions, concepts, and related research.

A. MOTIVATION

The energy needs and solutions in the maritime domain are evolving quickly, and constantly. International environmental standards are becoming more restrictive to the use of fossil fuels for seagoing vessels. Vessels have begun to switch to liquefied natural gas for fuel instead of diesel because the new standards require more expensive low sulfur diesel fuel to be used. In the latest developments, vessel owners have also begun to install hybrid power systems on board. A vessel may be classified as a hybrid-powered ship, if it has electric power produced by a diesel generator with a battery bank integrated into the electric propulsion system [1]. Currently there are only a few U.S. flagged vessels that can be considered hybrid-powered ships [2]. There are currently no U.S. flagged hybrid-powered cargo ships. However, a Norwegian vessel called the *Viking Princess*, shown in Figure 1, is claimed by the owner to be the first hybrid-powered cargo vessel in the world. According to the vessel propulsion manufacturer Wartsila, “The Norwegian vessel is now the first ever offshore supply vessel in which batteries reduce the number of generators aboard the ship. The new energy storage solution will improve engine efficiency, generate fuel savings and reduce greenhouse gas emissions” [3]. The owner of the *Viking Princess* Eidesvik conducted the research to prove that hybrid shipping is a viable and profitable enterprise. The U.S. Coast Guard has great interest in the concept from a regulatory perspective. A hybrid-powered ship, if built in the U.S., could have difficulty getting certified to sail due to the lack of regulatory standards. The current standards used by the U.S. Coast Guard to inspect the electrical propulsion of hybrid vessels are developed by third party auditors, also known as Class Societies, such as the American Bureau of Shipping [4]. There is also an interest in how a hybrid vessel would be of use to the U.S. Navy [5]. Overall, a hybrid ship will have the benefit of reducing emissions, engine maintenance, and fuel consumption.



Figure 1. Vessel *Viking Princess*. Source: [3].

B. PURPOSE AND RELATED WORK

The purpose of this thesis is to improve on an existing hybrid vessel system with the addition of supercapacitors (SC) to the vessel energy storage system (ESS). To study this hypothesis, similar specifications to the *Viking Princess*, along with the addition of SCs, was modeled and simulated [6]. The hybrid propulsion model in this thesis includes energy storage with lithium-ion (Li-ion) batteries and SCs.

The reason for adding SCs is to improve battery life and utilization. Batteries are energy-dense storage devices. This means that they can store a lot of energy but can only charge and discharge at a limited rate, taking anywhere from minutes to hours to charge. SCs, on the other hand, are power dense; they do not store nearly as much energy as a battery, but what energy they do transfer can be charged or discharged in milliseconds to seconds. Also, an SC has hundreds of thousands more charge and discharge cycles. The idea is that with the addition of the SCs, the battery can last longer and be used more efficiently [7]. Figure 2 shows the power density versus the energy density of energy storage devices. SCs could also extend the load range of the system because they are capable of absorbing and discharging at higher currents than batteries.

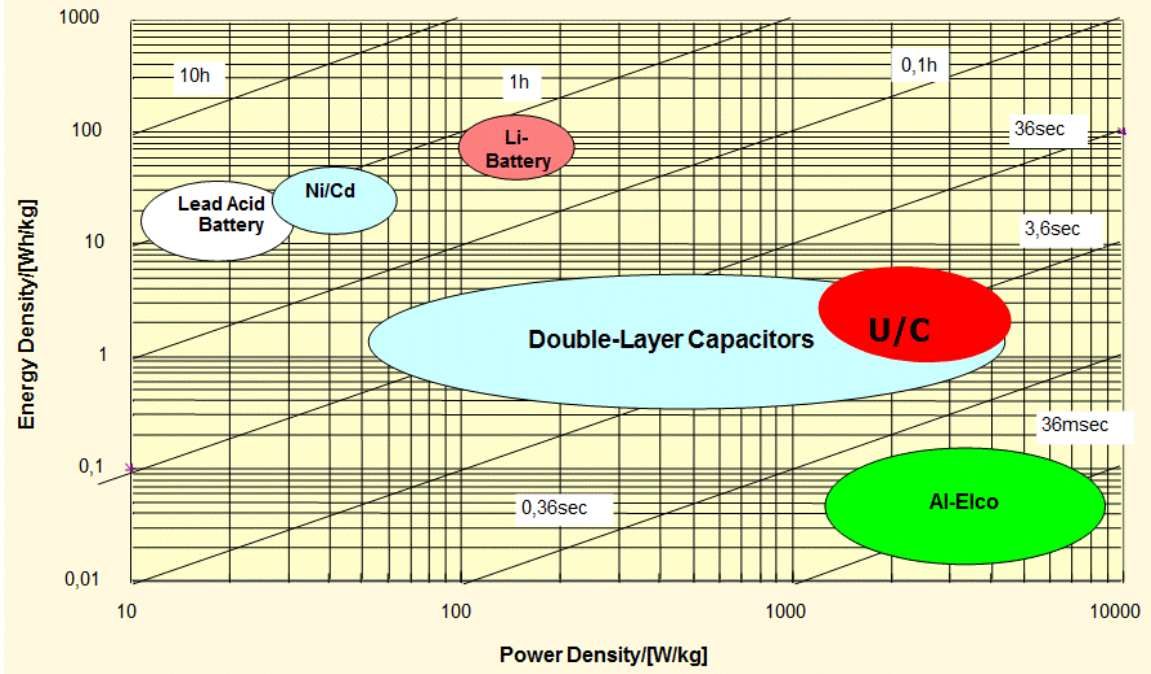

Figure 2. Power Density vs. Energy Density. Source: [7].

The model in this thesis was based on the model of an isolated microgrid developed by Dr. Giovanna Oriti and Dr. Alex Julian [8]. The simulation in this thesis was modified to simulate a vessel DC propulsion system. DC power was chosen because of the past research documenting the benefits due to the increased efficiency of DC grids [9], [10], and because DC power is part of the power distribution on the electric ship, USS Zumwalt, which was recently commissioned [11]. The SCs were added based on the idea from the use of them in current microgrid research and the benefits they provide [12]. There are many control methods and load scenarios for a hybrid vessel, but the load simulated in this paper is based on estimates informed by the author's experience as a licensed marine engineer [13]–[16].

As a licensed marine engineer, the author of this thesis became intimately familiar with propulsion systems and their behavior in all loading conditions. This paper focuses on the effects of different sea states a vessel might experience. As a vessel is sailing, a constant up and down wave motion is experienced from the buoyant force of the waves pushing up against the vessel, like a vehicle going along on a hilly road. As the vessel

ascends a wave it will be pushed back and pitched upward by the wave which causes the vessel control system to demand more power. In response, more fuel is sent to the engine and the power demand is met. As the vessel descends a wave or is pushed by a wave, the vessel senses that the engine is going too fast and the fuel delivery is lowered to keep the engine from over speeding and causing damage.

As waves get bigger this loading and unloading gets more varied and dramatic. If a vessel experiences heavy enough seas the engine cannot physically react to the sudden unloading, and the engine will overspeed+ and automatically shut down to prevent engine damage. A shutdown due to an overspeed event is a potentially deadly situation because the ship no longer has maneuverability to sail into the waves and can be swamped by broadside waves. A battery-SC combination in an EMS can help prevent this by acting as a dynamic braking system as it is currently utilized in trains and hybrid cars to help with slowing down. The motor in the system driving the wheels has the power reversed causing it to now have resistance and acting as a generator to produce power. This can be accomplished on a vessel during the unloading portion of the propulsion system as it descends a wave. The energy that might make the engine overspeed slows down the propulsion and acts as a generator instead of as a motor. The descent portion of the wave traveled can then have the energy produced stored in batteries. The SCs work to keep the batteries from high frequency currents that reduce their lifetime [8]. Figure 3 shows a block diagram of the concept of the simulated system and focusing solely on the propulsion.

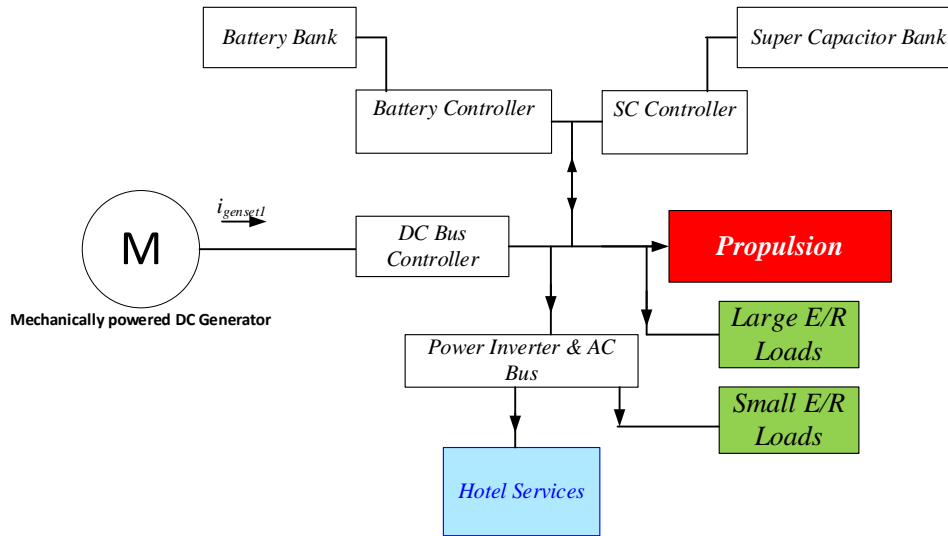

Figure 3. Hybrid Propulsion System Architecture

Of last note, some of this writing is based not on a particular source but on the author’s experience in the maritime industry. In particular, the author has experience sailing in different sea conditions and knowledge of vessel propulsion behavior under varying loads. The author’s licensed and professional experience includes several years in the U.S. Merchant Marine as an Engineering Officer and large cargo ship crew member on U.S. Flagged seagoing cargo ships. Additionally, the author spent several more years in the U.S. Coast Guard working aboard vessels as a U.S. Coast Guard Marine Inspector. In total, the author has accrued 16 years of experience working within the maritime domain.

THIS PAGE INTENTIONALLY LEFT BLANK

II. BACKGROUND

This chapter introduces key components to the simulation along with their characteristics and performance parameters. Along with that background, this chapter introduces the formulas used in the calculation of battery and SC metrics, and fuel efficiency.

A. BATTERIES

The batteries simulated for this thesis are Li-ion and are manufactured by Corvus Energy [17]. Li-ion batteries work by chemically storing energy. This is done by having two terminals: a cathode and anode. The cathode and anode are made of lithium and are placed in an electrolyte and kept apart by a separator. Charged lithium ions move between the separator and the terminals, according to whether the battery is being charged or discharged.

Li-ion batteries are currently the most commercially viable batteries with the highest energy density. The battery parameters used for the simulation are similar to the ones used in current hybrid vessels now in service, such as the *Viking Princess*. Corvus, the company that provided the battery bank for the *Viking Princess*, advertises a battery pack size of 50-1200V and 5.7-137kWh [17]. An 800V, 100 kWh battery pack was chosen so that there could be some flexibility for future designs to increase or decrease the voltage and/or energy.

In order to evaluate batteries with different specifications, a rating system is adopted as described below:

In describing batteries, discharge current is often expressed as a C-rate in order to normalize against battery capacity, which is often very different between batteries. A C-rate is a measure of the rate at which a battery is discharged relative to its maximum capacity. A 1C rate means that the discharge current will discharge the entire battery in 1 hour. For a battery with a capacity of 100 Amp-hrs, this equates to a discharge current of 100 Amps. A 5C rate for this battery would be 500 Amps, and a C/2 rate would be 50 Amps. [18]

Referring to this rating, Corvus also advertises a C-Rate of 6C as being the highest in the industry with no other manufacturer having a C-Rate higher than 5C [17].

The battery bank used here has a 125 kWh energy rating. If the energy of 100 kWh is divided by the 800V of the hybrid system, the result is a battery rating of 125 Amp hours (Ah). With a 6C rating that means that the batteries can charge at a rate of 750 Amps in 10 minutes. The SCs can help keep the battery from charging and discharging too often. A battery can be discharged at a higher rate than its C rating; remember that the C-Rate is mainly for a discharging rate threshold.

The analysis of the batteries is based on a mathematical model which is valid only within rated temperature. Since excessive heat may have negative effect on their performance. The battery packs simulated are actually air or liquid cooled. In order to find the power, we start from its definition

$$P_B = v_B(t)i_B(t) \quad (1)$$

where P_B is the power discharged or charged by the battery in Watts, $v_B(t)$ is the battery voltage, and $i_B(t)$ is the battery current. To determine the battery current, $i_B(t)$, the battery current is regulated by a PI controller which keeps its voltage close to a desired reference value [8].

The State of Charge (SOC) is an important measure of the remaining battery energy and it is usually expressed as a percentage of the remaining energy. Mathematically, it is defined by the following expression

$$SOC_B(t) = 100 \times \int_0^t \frac{v_{ref} i_B(\tau)}{E_B} d\tau \quad (2)$$

In this definition E_B represents the energy in the battery, and it can be expressed as

$$E_B = v_{b_bank} (Ah)_B 3600s \quad (3)$$

with v_{b_bank} as the battery bank voltage and $(Ah)_B$ as the battery Amp-hour rating. The constant $3600s$ represents the number of seconds in an hour, since (2) expresses t in units of seconds. The end goal was to get the energy units of amp hours converted into watt

seconds or joules. The arrangement of the battery bank is designed to meet the power system requirements by adding batteries in series to reach the desired DC voltage, and paralleling multiple branches to reach the desired Amp-hour capacity of 125 Ah.

The lifetime of a battery is determined by the manufacturer based on the number of discharges the battery can take within a certain temperature range. A typical Li-ion battery may have a discharge life of 500 - 5000 discharges. By definition in relation to lifetime discharges, when a battery is discharged the battery goes from fully charged to fully discharged.

A battery can typically discharge within a shorter time than its specified C-Rate and at higher currents. In a discharge cycle the battery is more heavily degraded at a lower SOC, than at a higher SOC. To increase the battery life it is best to try and keep a high SOC because the battery will not use as much energy to maintain the rated Ah. The simulation control system tries to maintain the SOC at approximately 90% to better simulate an actual hybrid system.

B. SUPERCAPACITORS

Unlike the batteries simulated for this thesis, which are being used on board commercial vessels, SCs have not been utilized on a commercial vessel with a diesel-electric, DC propulsion system. An SC works in a similar way to a conventional capacitor, which has dielectric material that is easily polarized and then coiled tightly across two electrodes that are insulated from each other. Energy is stored after opposite charged ions accumulate on the electrode plates and create an electric field [7]. If a voltage V is applied to the terminals, the displaced charge Q is related to the voltage as

$$Q = CV \tag{4}$$

C is the capacitance based on the permeability ϵ , cross-sectional area of the electrode A , and the distance d between the coiled layers.

$$C = \epsilon \frac{A}{d} \tag{5}$$

The available energy in the electric field is

$$E_c = \int Q dV = \frac{1}{2} CV^2. \quad (6)$$

In the case of SC construction, a separator is placed between the electrodes. This separator is a thin insulator and it takes the place of the dielectric material found in conventional capacitors. In addition, the separator is also coated with an electrolyte which doubles the effectiveness of the capacitor by storing additional charges. Therefore, twice the amount of stored charge in a conventional capacitor can be placed in the same amount of area within a SC.

The voltage of the SCs V_{SC} , was calculated by modifying and rearranging (6). First the minimum and maximum energy stored in the SC bank was calculated.

$$E_{\max} = \frac{1}{2} C_{sc} V_{\max}^2 \quad (7)$$

$$E_{\min} = \frac{1}{2} C_{sc} V_{\min}^2 \quad (8)$$

Next the following equation was used to set the SC voltage to allow half the SC energy to be used for charging, and the other half of the energy to be used for discharging [19].

$$V_{SC} = \sqrt{\frac{2}{\frac{1}{2} C_{SC} (E_{\max} + E_{\min})}} \quad (9)$$

Finally, a very important consideration when installing a capacitor bank is to make sure they are properly balanced and arranged to provide the optimal settings. Capacitors are arranged in series or parallel configurations to change the voltage and capacitance. When capacitors are placed in series the voltage increases while the overall capacitance decreases. To the unwanted lower capacitance of a series configuration, the capacitors can be placed in parallel. With the capacitors in parallel the capacitance will increase without changing the voltage.

The major advantage of an SC over a battery is that an SC can be charged and discharged much faster than a battery can. A battery can take hours to charge and several minutes to discharge. An SC can charge and discharge in milliseconds and perhaps in a few seconds for larger SC banks. The typical SC has a lifetime charge and discharge rate of at least 500,000 times [7]. When compared to batteries, SCs provide hundreds of times more charging and discharging cycles as seen in Figure 4.

Available Performance	Lead Acid Battery	Ultracapacitor	Conventional Capacitor
Charge Time	1 to 5 hrs	0.3 to 30 s	10^{-3} to 10^{-6} s
Discharge Time	0.3 to 3 hrs	0.3 to 30 s	10^{-3} to 10^{-6} s
Energy (Wh/kg)	10 to 100	1 to 10	< 0.1
Cycle Life	1,000	>500,000	>500,000
Specific Power (W/kg)	<1000	<10,000	<100,000
Charge/discharge efficiency	0.7 to 0.85	0.85 to 0.98	>0.95
Operating Temperature	-20 to 100 C	-40 to 65 C	-20 to 65 C

Figure 4. Ultracapacitors vs. Battery and Conventional Capacitors.
Source: [7].

C. FUEL EFFICIENCY

Fuel efficiency was an important aspect of this research to demonstrate the potential benefits of hybrid vessel technology. Fuel efficiency is based on a ratio of the amount of chemical energy contained in the fuel being used and the output mechanical energy of the prime mover. To calculate fuel efficiency, η being the ratio between the amount of chemical energy put into an engine E_f , in the form of diesel fuel consumed by the engine, and the amount of actual mechanical energy that was produced by the engine E_{Eng} [20].

$$\eta = \frac{E_{Eng}}{E_f} \quad (10)$$

Table 1 shows the fuel consumption per hour for the engine used in the ship modeled.

Table 1. Diesel Engine Fuel Consumption per Hour.
Adapted from [5].

Cylinder output	kW	500
Fuel consumption at 100%	g/kWh	188.1
Fuel consumption at 85%	g/kWh	185.3
Fuel consumption at 75%	g/kWh	185.2
Fuel consumption at 50%	g/kWh	193.5

A diesel engine at low load is the most inefficient setting to run at. Diesel engines are designed to work near their rated load for the best performance. At lower loads the amount of energy produced is proportionally lower than the amount of energy put into the engine. At higher engine loads the intake air temperature increases along with air density of the air being forced into the engine from the engine turbo charger. This increases fuel atomization aiding in the combustion process and in turn produces more power. At lower loads fuel and air have a harder time mixing and there is a less efficient combustion process within the engine cylinders.

The energy in diesel fuel is measured by the kWh of energy in a gallon of fuel.

$$Fuel_{energy} = \frac{kWh}{gal} \quad (11)$$

Most diesel fuels have between 31.5–40 kWh/gal of energy. A lower energy value refers to a heavily refined, more expensive, and more environmentally friendly fuel like ultra-low sulfur fuel. A fuel with a higher amount of energy is less refined and less expensive. Since the energy content in fuel can change depending on the fuel grade, the fuel consumption will not remain constant for a constant power output. Lower refined diesel has more energy in the same volume of liquid compared to a highly refined fuel thus the fuel consumption rate will decrease. To calculate the efficiency a constant is needed for the energy in the fuel used in the simulation. This simulation uses a fuel energy constant of 36.0679 kWh/gal taken from the U.S. Army annual fuel consumption report for the fuel used in generators,

and can be considered a practical and common amount of energy in diesel fuel being used by the military [20].

To begin the analysis of the fuel efficiency, the fuel consumption data from Table 1 was plotted in Figure 5. From this plot the curve fitting tool in MATLAB was used to get a quadratic equation so the fuel consumption could be calculated at any load, as a percentage of the total amount of power in kW that a single generator can produce.

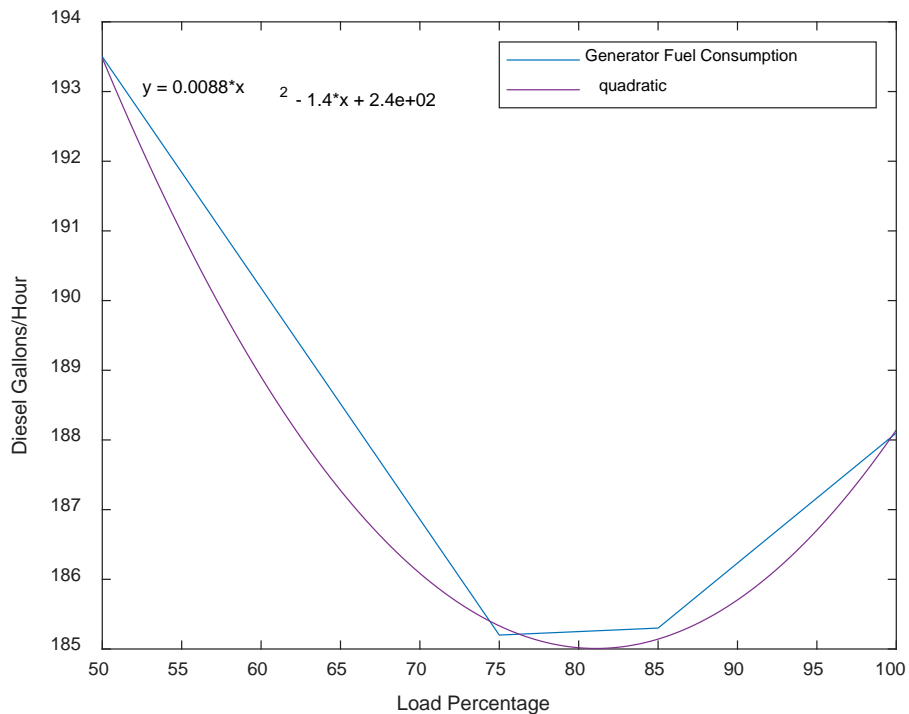

Figure 5. Diesel Engine Fuel Consumption

Next, the following equation was used to calculate the kWh/gal to determine the amount of energy which could be associated with a set volume, regardless of the amount of energy contained in said volume of liquid fuel [20].

$$\frac{kWh}{gal} = \frac{P_{Load}(FC / hr)}{1000} \quad (12)$$

In equation (12), P_{Load} is the power at a given mechanical load on the system and FC / hr is the fuel consumed per hour. Finally, to get the efficiency the fuel energy constant of 36.0679 kWh/gal for the fuel chosen is used in this equation:

$$F_{Eff} = \left(\frac{kWh}{gal} \right) / F_{EC} \quad (13)$$

with F_{EC} as the fuel energy constant and F_{Eff} as a percentage [20].

III. HYBRID SHIP PROPULSION MODEL

This chapter explains the methodology used to create a computer simulation model of a hybrid vessel propulsion system. The model includes the DC distribution bus of a diesel electric propulsion system; auxiliary loads are not included. The model consists of a DC load on a motor that would propel a ship through the water and with a load profile based on sea wave action, battery and super capacitor banks, and a control scheme. A diagram of the model is shown in Figure 6, as implemented in the SIMULINK software. The different components of the model are discussed in the following sections.

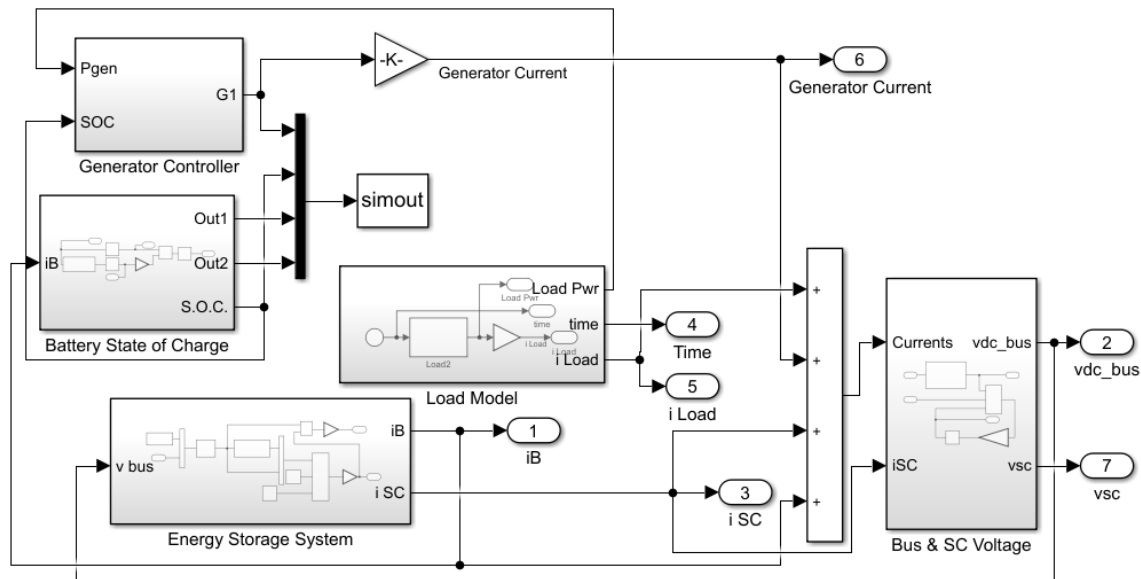

Figure 6. SIMULINK Implementation of a Hybrid Ship Propulsion System

A. LOAD MODEL

The load model simulates load changes experienced by a ship sailing under various sea conditions. To simulate the wave action a ship might experience a sine wave was used in the MATLAB code as the power demand on the generators. Next, a lookup table was used in the SIMULINK model in which the MATLAB sinusoidal waveform would be placed. This sinusoidal waveform was changed in magnitude to simulate changes in sea

conditions from a light varying load, then to a moderate load to simulate common sea conditions in some parts of the world like the North Sea, and finally the simulation was changed to a large load to simulate heavy seas as if a ship was going through a storm.

The magnitude of the sinusoidal waveform for the load was based on the power capable of being produced by a ship with a 5000 kW propulsion plant consisting of two 2500 kW DC drive motors. The vessel propulsion system was limited by a governor at 95% of the rated load to prevent damage to any mechanical components and reduce wear on the engines. The lowest load was also governed at 5% to prevent reverse power flow, and the possibility of the generators being motorized causing damage to mechanical components. Therefore, for the simulation the load on the system did not exceed 95% of the rated load or 4750 kW and it did not go below 5% of the rated load.

The frequency of the load depends on the frequency of the waves, usually measured by when the crest of a wave passes a point in a certain amount of seconds. The frequency of waves can be fairly constant or at times even unpredictable. For this simulation the frequency of the waves, 0.125 Hz, was kept constant with 8 second wave periods. In lighter loads that means that the vessel would most likely travel mostly through a wave every 8 seconds with minimal pitch. In heavier loads a vessel is unable to just pass through a wave as easily and it has to go over the wave because of the size of the wave. In heavy sea conditions a vessel can pitch wildly and will travel up a wave for four seconds and then down the wave for 4 seconds. Three different load profiles are used to simulate sea conditions of light, moderate, and heavy.

The loads were initially in kW and then converted to current, with K a gain in the subsystem, by dividing the DC bus voltage setting to get a current representing the currents needing to be met. The first load profile is a low load profile simulating a variance in wave height of about 10 % to simulate light sea conditions. This meant that the average load on the vessel propulsion from wave action would be at 85% of the rated power and the load could go up to the governed 95% of rated power, and go down to 75%. The next profile was to simulate moderate sea conditions, such as a commonly sailed through storm squall at sea. This was achieved by having an average load from wave action setting at 70 % of the rated load, with a peak to peak of 50% of the rated load with a maximum load of 95%

of the rated load and a minimum of 50% of the rated load. The last load profile simulated heavy seas which cause the engine load to rail from maximum to minimum load requirements. The heavy seas load profile had an average of 50% power usage with a 45% oscillation from 5% of the rated load up to 95% of the rated load. This load profile is the most extreme consisting of the heaviest storms a ship is willing to go through safely. The SIMULINK subsystem of the load profile is seen in Figure 7.

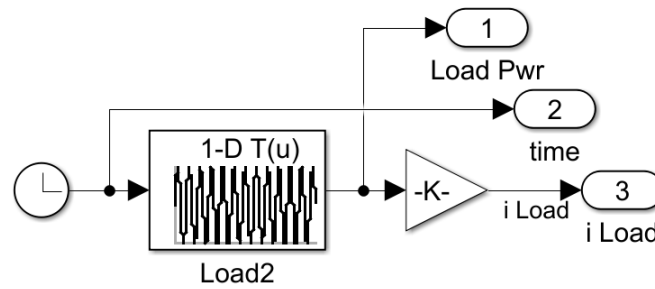

Figure 7. Load Model

B. ENERGY STORAGE SYSTEM

The energy storage devices included in the ESS were lithium-ion batteries and super capacitors (SCs). The current out of the batteries and SCs was controlled via a proportional integral (PI) controller and a low pass filter which was used to determine the current balance between the batteries and SCs [7], [8]. First, a reference voltage of 800 volts DC was used to control the DC bus. 800 volts was chosen because it was similar to the Corvus optimal battery bank arrangement advertised by Corvus and because higher voltages are used in other DC ship power system research [7], [13]. Refer to Figure 8 to see the ESS block from SIMULINK.

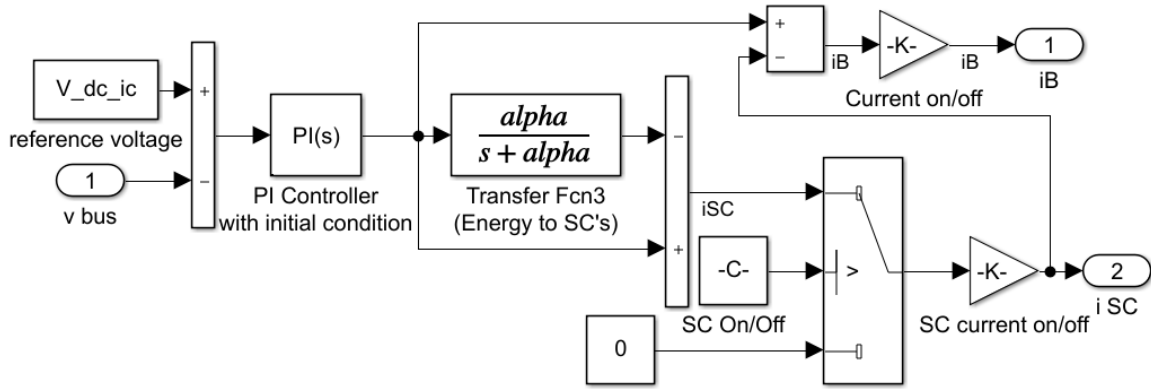

Figure 8. Energy Storage System Model as Implemented in SIMULINK

The current from the energy storage system is initially calculated by subtracting the bus voltage from the reference voltage to obtain the voltage error. Next the error signal goes through a PI controller that was tuned by trial and error with proportional and integral gains as $K_p = 4$ and $K_i = 40$ respectively. In Figure 8 the current from the system is separated into two components: the high frequency component goes into the SCs and the low frequency current goes into the batteries. [16]. This control method ensures that the SCs are responsible for the high frequency currents, thus reducing the stress on the battery by smoothing out its current ripple and sending only low frequency currents to the batteries. Gains and switches were added to simulate the effects when only the batteries are in use and when no energy storage devices are utilized so comparisons could be made about the system with or without an ESS.

C. GENERATOR CONTROLLER

The generator output is controlled by a Simulink subsystem utilizing the power demand from the load profile and the SOC of the batteries for the input. The controller can make the generator operate in two ways. First, the generator can operate in a non-hybrid mode without the batteries and SCs connected to the bus and the generator will therefore meet the load demand exactly. Second, the generator can operate at a constant RPM and provide continuous power while the batteries and SCs provide the power demands not met by the generator. The batteries and SCs will also charge when the generator provides more

power than needed for the propulsion motors. A third method not explained in this thesis allows generator to have small oscillations in phase with the load oscillations caused by the waves. Figure 9 shows the generator control subsystem.

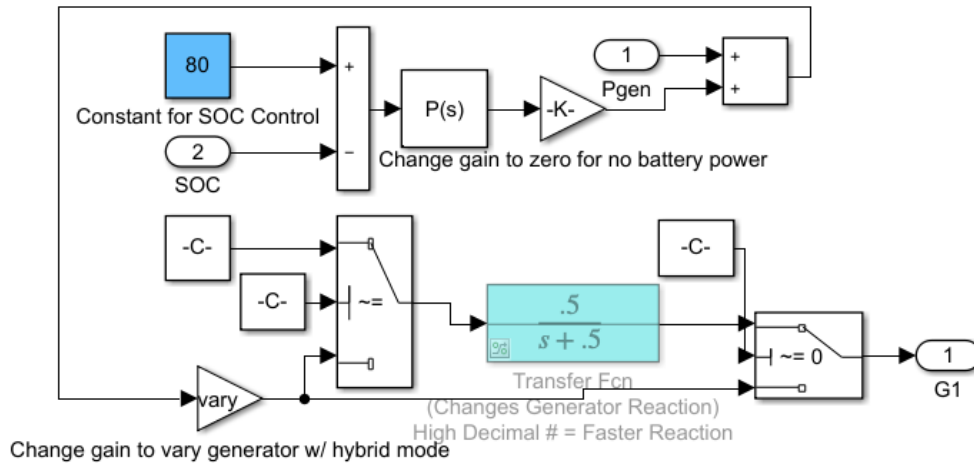

Figure 9. Generator Controller

To change between the different operating modes a series of switches and gains are utilized. For a non-hybrid operation, the load power demand is what the generator will produce and the current gains shown in Figure 9 are kept at zero for the batteries and SCs. In the hybrid operation with a constant power output from the generator, the level of power out is set by the user in the form of a constant and the batteries and SC gains are set to one. The SOC subsystem is explained in the next paragraph of this chapter.

The battery SOC subsystem uses the battery current as an input through a relay and then an integrator which determines the battery SOC as a percentage of total battery energy available. The SOC controller detects whether the current from the battery is positive or negative and will send negative current values through a data type converter. The converter is used to convert a logic value into a floating point of one data type and keep a real-world value of the input in the form of a one or zero. Next, the converted data is passed through a relay. This signal is then multiplied by the battery current as a percentage of the load (2). Finally, the signal is passed through an integrator with initial condition and limits. The initial condition for SOC was arbitrarily chosen to be 92 %. The limits for SOC were set at

a max of 100% as not to damage the batteries and a lower limit of 60% to keep the batteries from discharging too much which can limit the battery life. The battery SOC is then used when varying the generator power to the system in hybrid mode to help determine how much power the generator will provide when compared to the batteries and SCs. The subsystem for the battery SOC is shown in Figure 10.

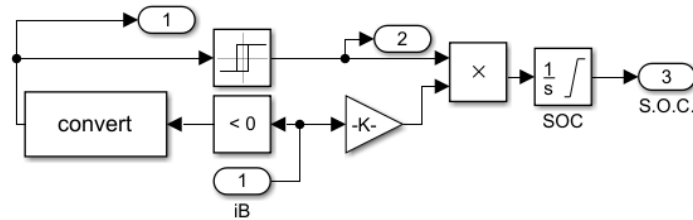

Figure 10. Battery State of Charge Subsystem

D. BUS AND SC VOLTAGE

The bus & SC voltage subsystem determines the voltages of the ESS by using the currents from all of the components in the SIMULINK model. The currents from the generators, the SC currents and the battery currents are added together and then the negative load current is added. From there the currents are passed through a PI controller to get the voltage of the DC bus. The same DC Bus voltage is used in ESS SIMULINK block. Next, the SC voltage is calculated with the SC voltage feedback. The SC voltage feedback is found when the DC bus voltage is multiplied by the SC current, then divided by the SC voltage feedback. The outgoing current is then divided by the SCs and then integrated to get the SC voltage. The subsystem for the Bus and SC Voltages is shown in Figure 11.

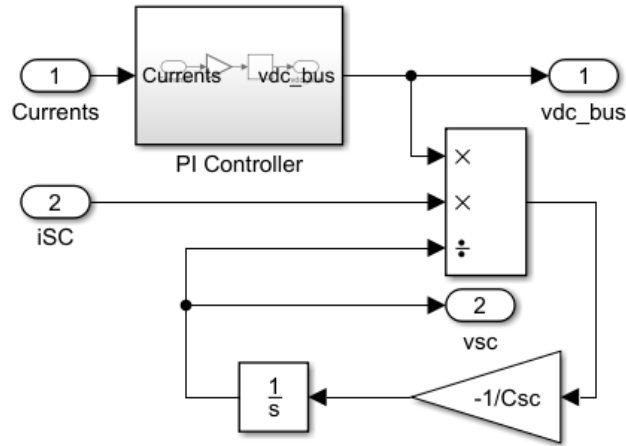

Figure 11. DC Buss and SC Voltage Subsystem

E. MODEL PARAMETERS

The parameters used in the simulations are shown in Table 2 with the battery parameters and specifications being based on real-life availability from the commercial ESS company, Corvus [17].

Table 2. Hybrid Model Parameters

Parameters	Variable	Value	Units
Bus Voltage Reference		800	V
Battery Bank voltage		800	V
Battery Amp Hours		125	A·h
Battery strings in parallel		8	
Capacitor Size		125	mF
Capacitor Bank		250 x 4 x 100	
Max Capacitor Voltage		820	V
Minimum Capacitor Voltage		780	V
Current Controller Proportional Gain		4	
Current Controller Integral Gain		40	
Generators Rated power		2 x 2500	kW

The eight parallel battery banks were chosen to maximize the energy that could be absorbed by the ESS during peak loads. If there are too few parallel battery banks, the batteries will charge too fast and may not be utilized in possible load scenarios. The SC parameters were chosen to have similar specifications as the batteries. The capacitor bank size was chosen based on experimental results where if there are not enough SCs the model will be overloaded and malfunction by causing MATLAB to have a singularity. The PI gains were also chosen experimentally through trial and error and appear to be optimal values. Lastly, the generator size was chosen because it is close in value to a real-world application in use on the *Viking Princess* [21].

IV. RESULTS AND ANALYSIS

This chapter explains the results obtained after running several time-domain simulations of the vessel propulsion model. The model was implemented in SIMULINK and demonstrated two different modes, non-hybrid and hybrid mode. Each mode was simulated at three different average power levels of 85%, 70%, and 50% based on the sea conditions, with 85% average load being light sea conditions, and 50% load being heavy sea conditions. The analysis includes looking at the efficiency of each mode and load level, by comparing fuel consumption specifications and the effects the SCs have on the ESS.

A. NON-HYBRID MODE

The non-hybrid mode results are obtained from simulations of the vessel model without any energy storage devices.

1. Light Sea Conditions

The first simulation of the non-hybrid mode has an average load of 85% with a change in load of plus 10% and minus 10%. A run time of only 100 seconds was simulated because the system is always in steady state when in non-hybrid mode. In Figure 12 it can be observed that the load demand and the generator output are the same, as expected, without other power sources. Figure 13 is an enhanced view of Figure 12.

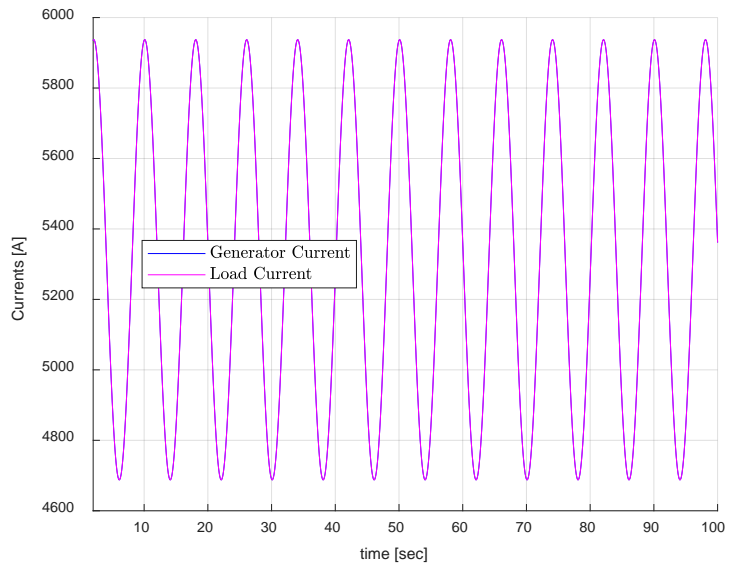

Figure 12. Non-hybrid Load Currents at 85%

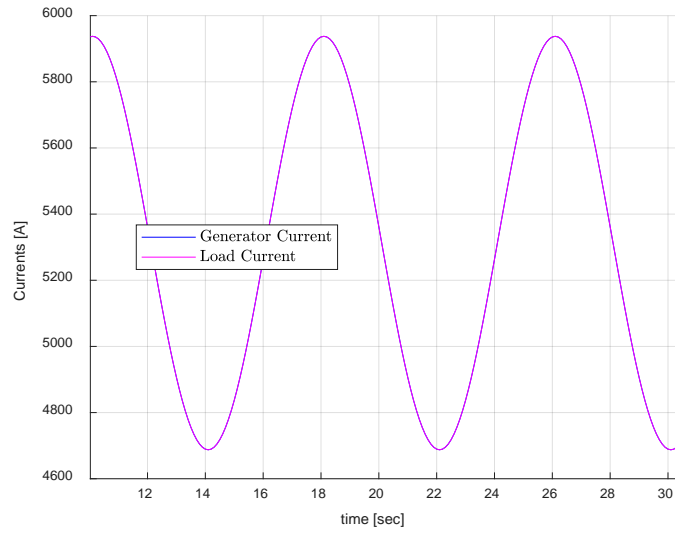

Figure 13. Figure 12 Enhanced

The mean fuel efficiency for this load profile was 31.83% with a mean fuel consumption rate of 371.2 gal/hr as shown in Figure 14.

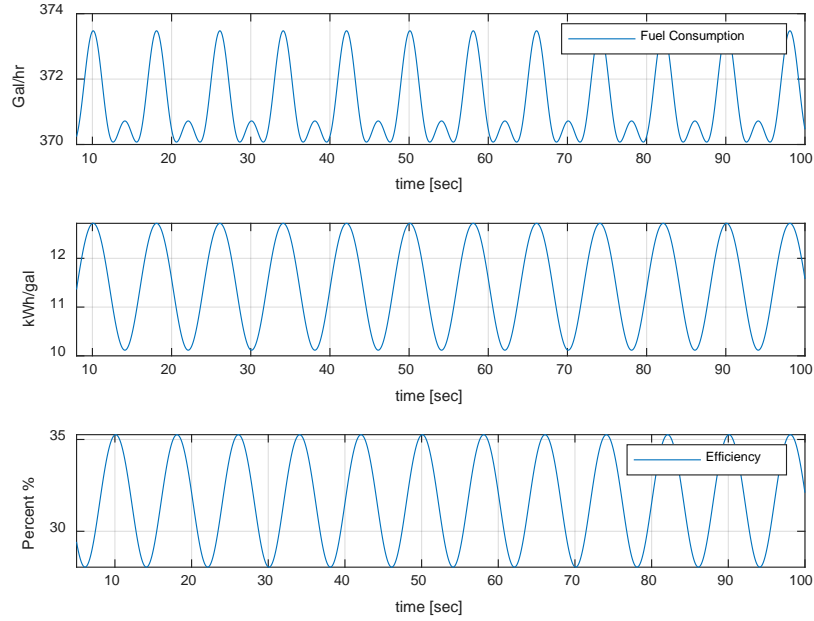

Figure 14. Non-hybrid Fuel Efficiency at 85% Load

2. Moderate Sea Conditions

Moderate sea conditions are simulated with the load set at 70% of the mean power demand with a variation of plus 25% and minus 25% of the rated load. Figure 15 shows an enhanced view of the moderate load profile. The generator and the load at the same value to show the control method having the generator follow the load exactly.

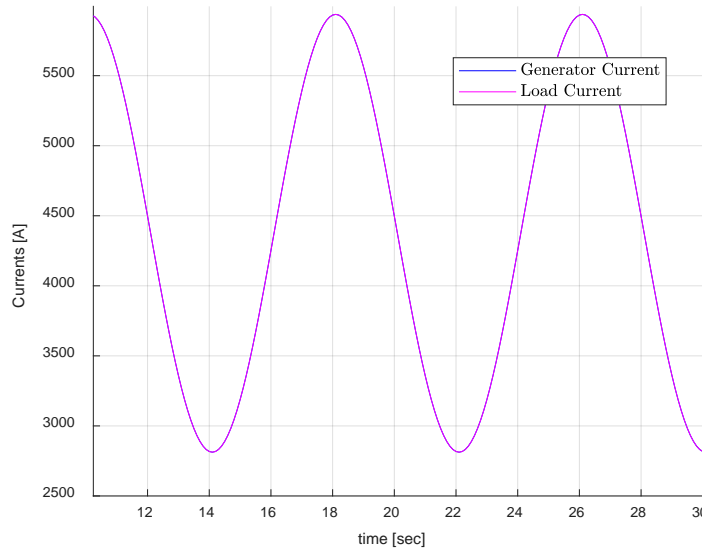

Figure 15. Non-hybrid Mode Load Currents at 70%

The efficiency in this case begins to drop with respect to light sea conditions, as shown in Figure 16, because the generators are not operating close to their optimal range during this procedure. The optimal range is as close as possible to 100% of the rated load, which is where the maximum efficiency is reached. However, as mentioned before the generators should be limited to 95% of the rated load to keep them from being damaged. During moderate sea conditions, the generators cannot stay close to the optimal load because of the oscillation due to load changes and can only peak at 95% and then go down to 75%. The simulation demonstrated quite accurately a ship climbing up, and over the crest of a wave. Then followed by an example of the ship pitching down and traveling down the wave while reducing engine power to avoid an over speed situation. Once the ship reaches the trough of the wave, the engine must increase power to overcome the loading from the wave action, while the ship pitches up and begins to travel up the wave. The mean fuel efficiency at a moderate load is now lower at 26.07% resulting in a higher mean fuel consumption of 377.5 gal/hr.

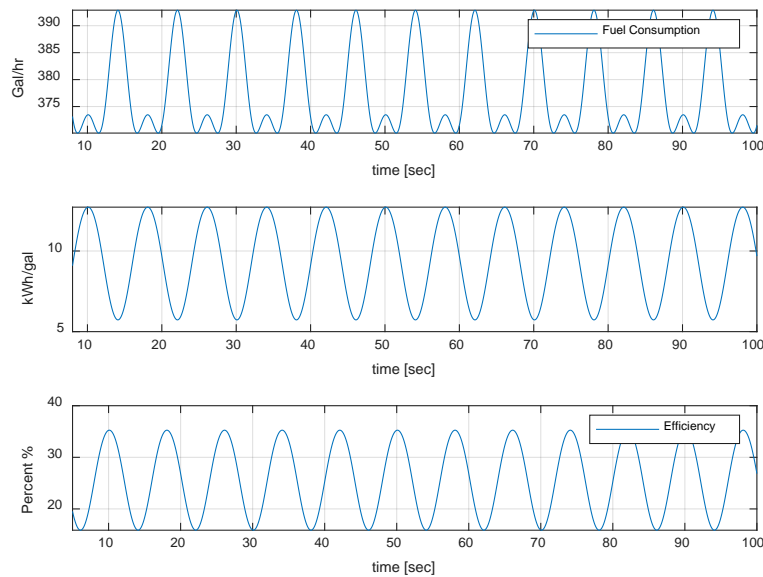

Figure 16. Non-hybrid Fuel Efficiency at 70% Load

3. Heavy Sea Conditions

The final non-hybrid simulation load profile is heavy seas with a mean power demand of 50% with a variation of plus 45% and minus 45% load. This is the most extreme demand that can be placed on a vessel and it happens in strong storms at sea. Figure 17 shows the extreme variation of load changes that would be experienced by the engines in heavy seas.

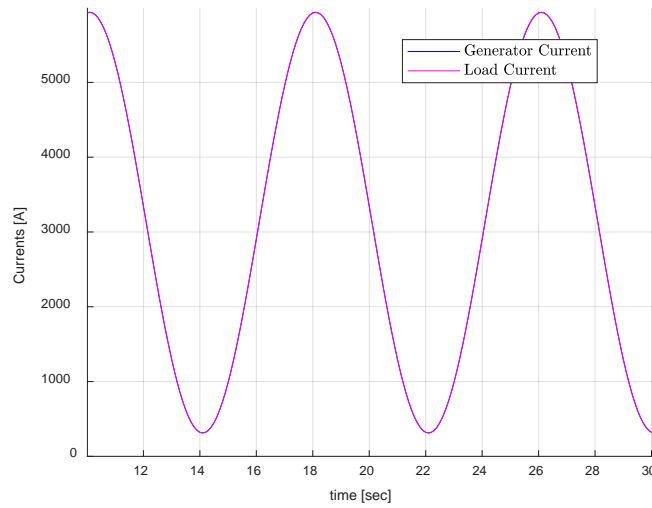

Figure 17. Non-hybrid Mode Load Currents at 50%

Heavy seas cause ship engines to work very hard to keep up with the load changes, as shown in Figure 18, and the efficiency and fuel consumption are approaching the worst possible values. In this simulation the fuel mean efficiency is 18.6% and results in a higher mean fuel consumption of 403.5 gal/hr.

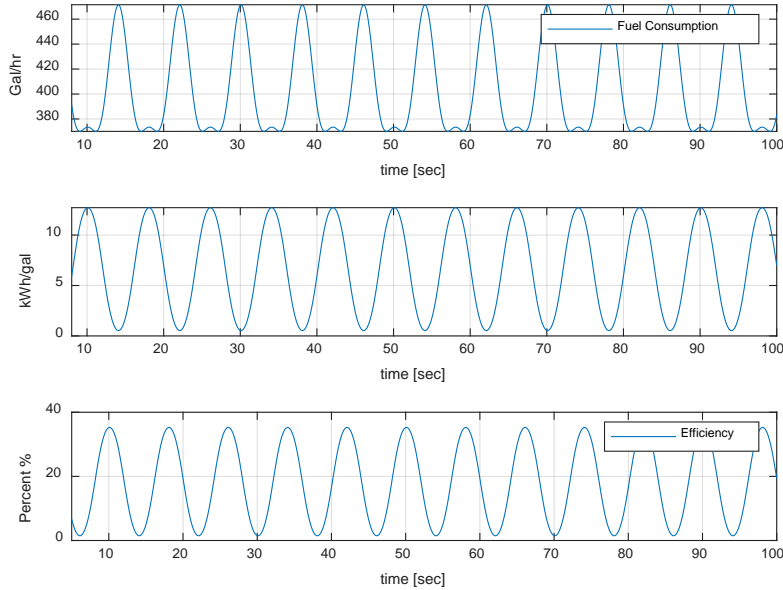

Figure 18. Non-hybrid Fuel Efficiency at 50% Load

B. HYBRID MODE

For hybrid mode operations, an energy storage system (ESS) is added to the simulated propulsion system of the vessel. Two different scenarios are simulated in this mode of operation: 1) the ESS includes batteries and SCs, 2) the ESS includes only batteries and no SCs. The simulation time for hybrid mode was set to 1,000 seconds or about 16 minutes, because the recharging of the battery takes longer than the 100 seconds and the system needs the extra time to reach steady state. The hybrid mode simulations show that the prime movers are controlled to operate at a constant load, while the ESS supplies the peak currents drawn by the electric motors. Since the generators operate at a constant load in hybrid mode regardless of the load on the propulsion system, the mean

fuel efficiency is the same for all load profiles and is shown in Figure 19. In the hybrid mode each generator produces 90% of its rated power, or 4500 kW at a constant level. When the generators work at a constant 90% load, the mean fuel efficiency is 33.59% and the mean fuel consumption is 371.5 gal/hr.

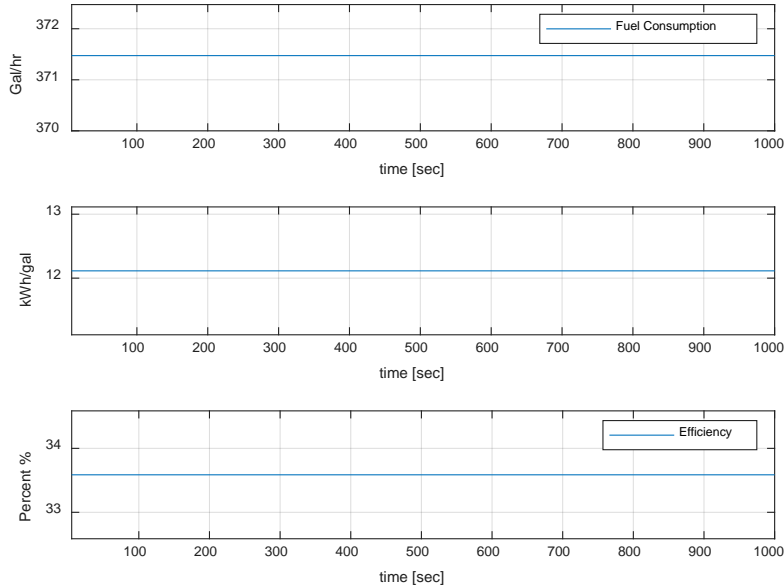

Figure 19. Hybrid Mode Fuel Efficiency at 90% Generator Power

Next, the hybrid mode simulations also show the ESS charging when the load demand is less than what the generators can produce. Under all load conditions, the generators can produce the majority of the power demanded by the load except for the peaks of the power that the ESS picks up. When excess power is available, that power can be diverted to other needs such as ship hotel services or other engine room loads. For this, research any excess power generated is diverted to charging the batteries and SCs.

Fuel efficiency and fuel consumptions are compared in Table 3 for the different scenarios in hybrid and non-hybrid mode of operation. A comparison of the maximum currents supplied by the batteries and the SCs is presented in Table 4 for scenarios with and without SCs.

Table 3. Fuel Efficiency and Fuel Consumption at Each Sea Condition in Hybrid and Non-hybrid Mode

Sea Condition	Fuel Efficiency		Hybrid at 90% of Rating	Fuel Consumption gal/hr		
	Non- hybrid	Hybrid		Non- hybrid	Hybrid	Hybrid at 90% of rating
Light	31.83%	31.82%	33.59%	371.2	371.5	371.5
Moderate	26.07%	26.07%	33.59%	377.5	372.2	371.5
Heavy	18.60%	17.90%	33.59%	403.5	387	371.5

Table 4. Current Peaks of the Batteries and SCs with and without SCs

Sea Condition	Current Peaks [A]		
	Batteries with SC	SCs	Batteries without SCs
Light	-310.1	-628.2	-938.4
Moderate	-1251	-1574	-2815
Heavy	-2400	-2840	-5317

1. Light Sea Conditions

During light sea conditions and with the generators operating in hybrid mode at 90% rated load, the fuel efficiency is increased by 1.76% with only 0.3 gal/hr more in fuel consumption when compared to running at 85% rated load in non-hybrid mode. This means that a 5.5% change in fuel efficiency only costs 0.08% more in fuel consumption and shows the benefits of operating within the manufacturer suggested range of loads. Figure 20 shows the generator and load currents during hybrid mode and an average power demand of 85% rated load.

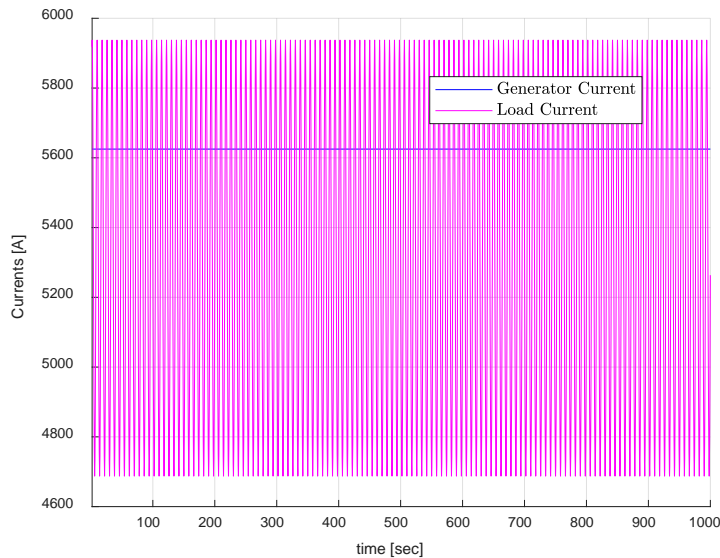

Figure 20. Light Load Hybrid Currents

Figure 21 is a side by side comparison of simulations with and without SCs, respectively. In Figure 20 (a) the battery is shown charging and settling at 300 A while the SCs supply a much larger current as seen in Table 4. In contrast, in Figure 20 (b) the battery supplies all the current demanded by the load when there are no SCs in the ESS. With the battery as the only part of the ESS, the charge and discharge cycles of the batteries will shorten the life time of the batteries without the SCs contribution. Figure 22 also shows a comparison between the batteries state of charge (SOC) when SCs are used versus when

they are not and once the batteries are fully charged, the extra energy could be used for other engine room loads.

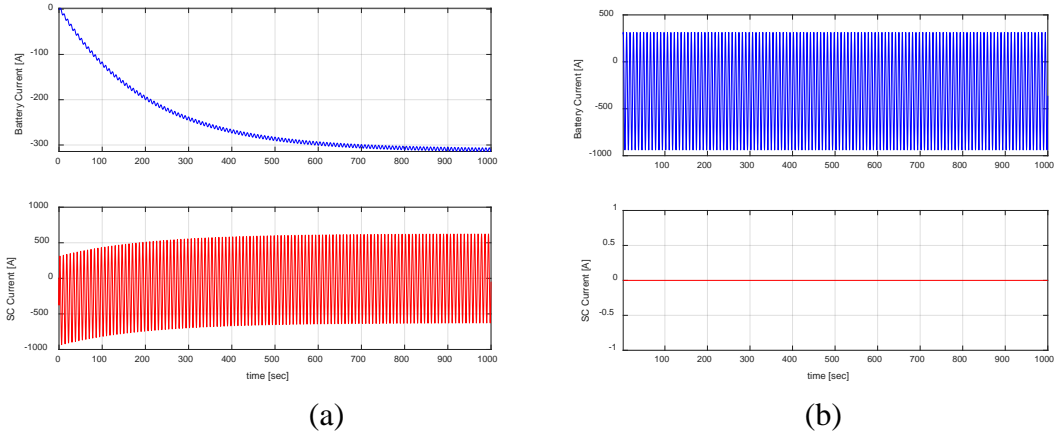

Figure 21. Light Load Comparison with SCs (a) and without SCs (b)

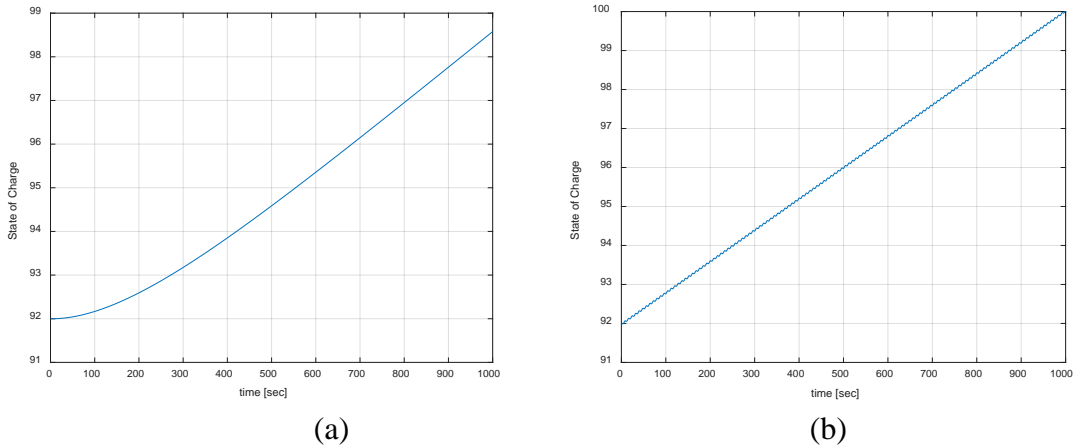

Figure 22. Batteries SOC with SCs (a) and without SCs (b) at Light Load

A possible alternative to operating in hybrid mode with the generators at 90% rated load is to run the prime mover engines at a constant 85% rated load to allow the ESS' current to oscillate evenly over the load average of 85%. There is a slight disadvantage when setting the generators at a constant speed of 85% rated load, the overall efficiency drops by 0.01% to 31.82% compared to the non-hybrid mode operating at the same load.

This is because in the hybrid mode the prime movers are at a constant 85% rated load and unable to take advantage of the higher fuel efficiency that the non-hybrid mode can reach when peaking at 95% rated load. However, the benefits of running the generators at a constant 85% rated load is a fuel consumption of 370.35 gal.hr, there is less wear and tear on the generators' diesel engines and the energy storage is utilized to its full potential.

2. Moderate Sea Conditions

In moderate sea conditions where waves are a little larger, the ship must work harder to maintain a forward momentum. Figure 23 shows that the load demand from the wave action has an average of 70% of the generators' rated load. When the generators operate at 90% of the rated speed they produce excess energy which again is used to charge the batteries and SCs. Once the batteries are fully charged, the extra energy could be used for other engine room loads.

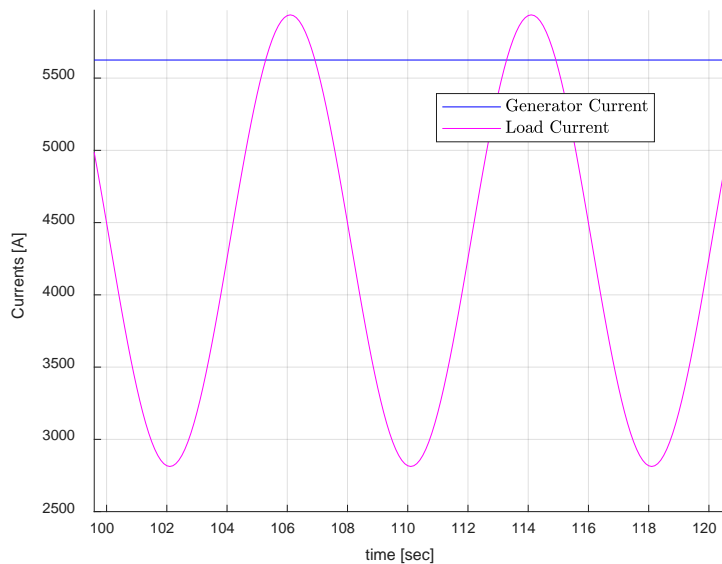

Figure 23. Moderate Load in Hybrid Mode: Load and Generators' Currents

In this moderate load situation, the excess power produced by the generators would need to be diverted elsewhere for maximum efficiency. Otherwise the batteries would reach

full charge and only the SCs would be utilized. Figure 24 shows the side by side comparison of the simulated battery and SC currents with and without SCs respectively. In this case the battery is taking a lot of current in charging and not providing power. Figure 25 shows the batteries' SOC with and without SCs.

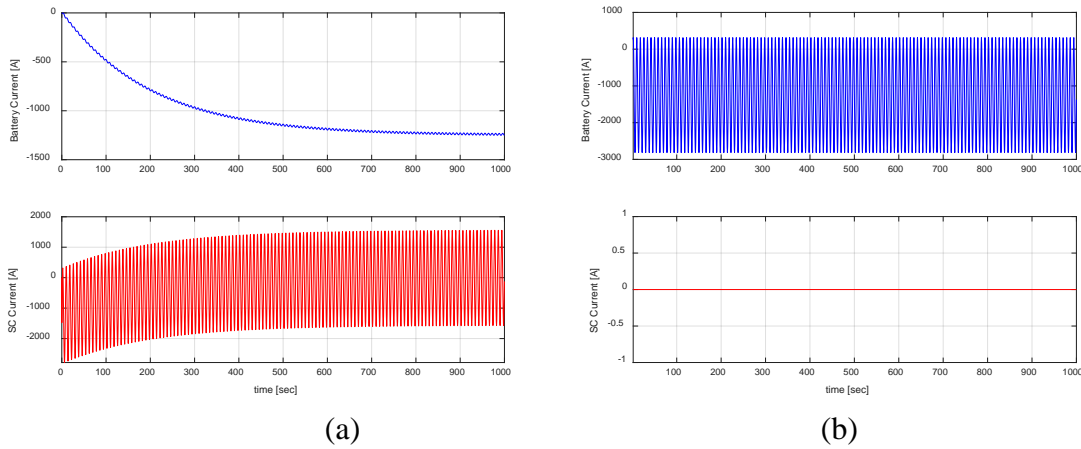

Figure 24. Moderate Load Hybrid Use of SCs Comparison

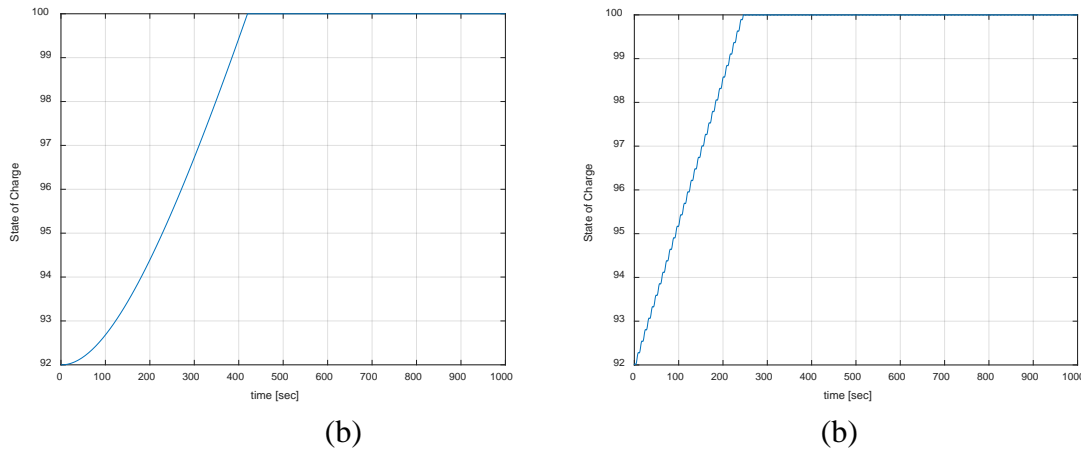

Figure 25. Moderate Load Batteries SOC with (a) and without SCs (b)

If the extra power cannot be diverted to other loads, then the generators could run at a steady 70% of the rated power and the ESS could take the load oscillation peaks as seen in Figure 26.

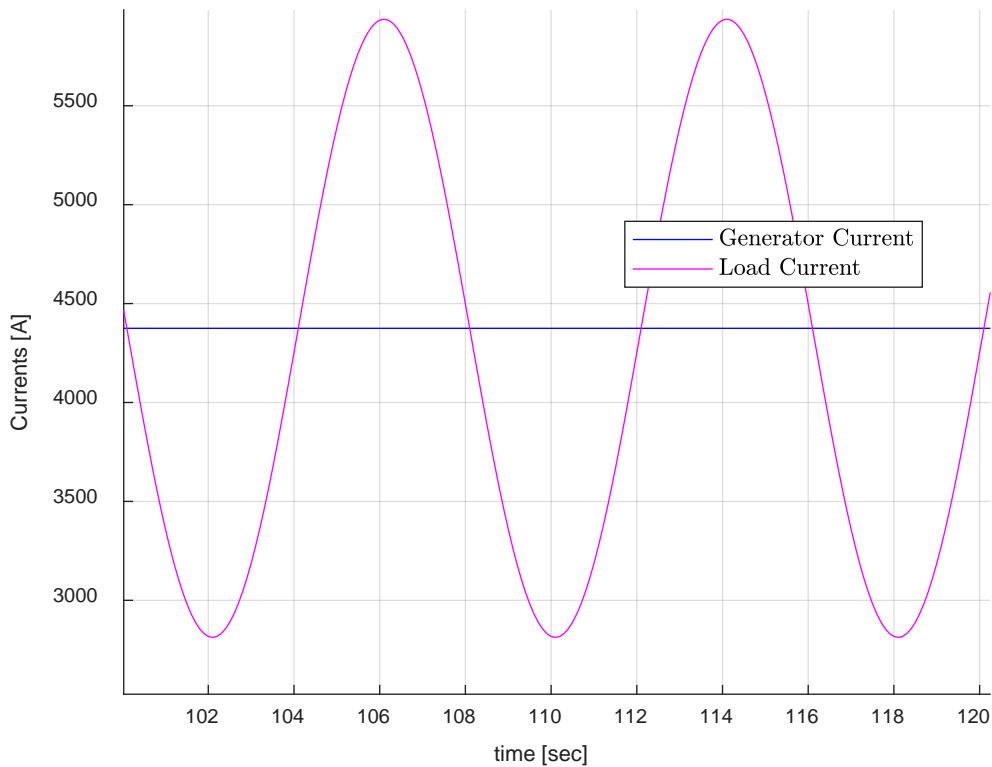

Figure 26. Moderate Load and Generators at 70% Power

In this simulation, the generators run at 70% of the rated load, the batteries and SCs are evenly oscillating across the load, charging and discharging the same amount. The generators no longer go into a more inefficient area below 70% as seen in the non-hybrid mode operation. Instead the outcome is shown to be better with energy storage devices. While the efficiency is still the same at 26.1% the fuel consumption has been reduced by 5.3 gal/hr to 372.2 gal/hr. Finally, the comparison in Figure 27 shows how well the SCs complement the batteries, with the SCs taking the higher current peaks to keep the battery current ripple low. The battery comes to steady state and its current features a 10 A peak while the SC current has a peak of 3000 A. Figure 28 shows the battery SOC with and without SCs for the scenario in which the generators run at 70% load.

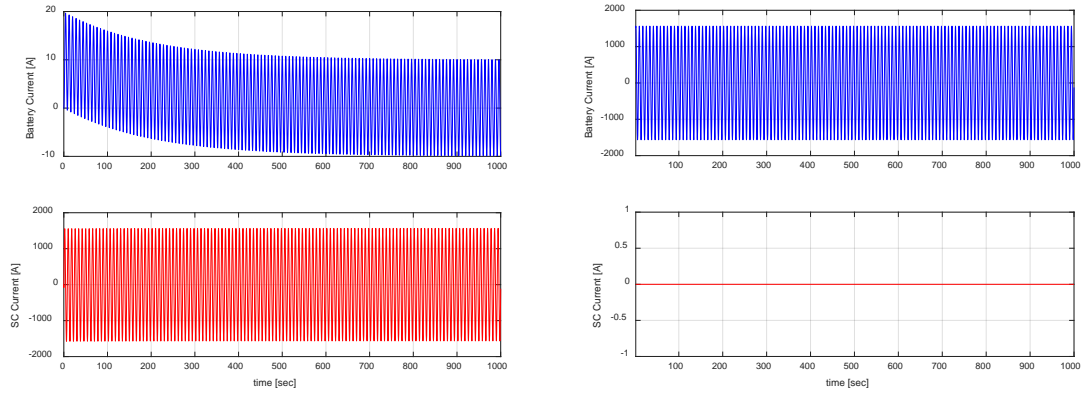

Figure 27. Moderate Load at 70% Hybrid Power SC use Comparison

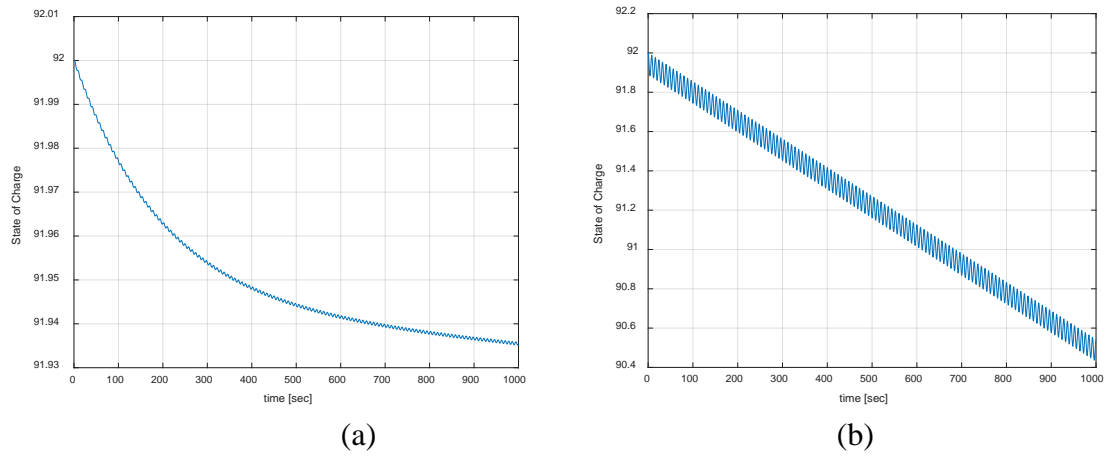

Figure 28. Battery SOC Comparison at 70% Load on the Generators with SCs (a) and without SCs (b)

3. Heavy Sea Conditions

Heavy sea conditions represent the rare occasion, perhaps a few times a year, when the largest of storms are sailed through by a cargo vessel at sea. Under these extreme load changes from sailing over large waves, a diesel generator is under immense strain from constantly loading and unloading, going between the minimum and maximum engine power. Again, it is most beneficial to run the generators at a constant 90% of the rated load. As seen in Figure 29, the constant load at 90% will provide the most efficient configuration, but there is a vast amount of power that is not being used effectively. All of the load currents that are less than what the generators are providing go to charging the batteries in a short amount of time. After the batteries are charged then only the SCs will be utilized and the engine power must be reduced to keep from overcharging the batteries.

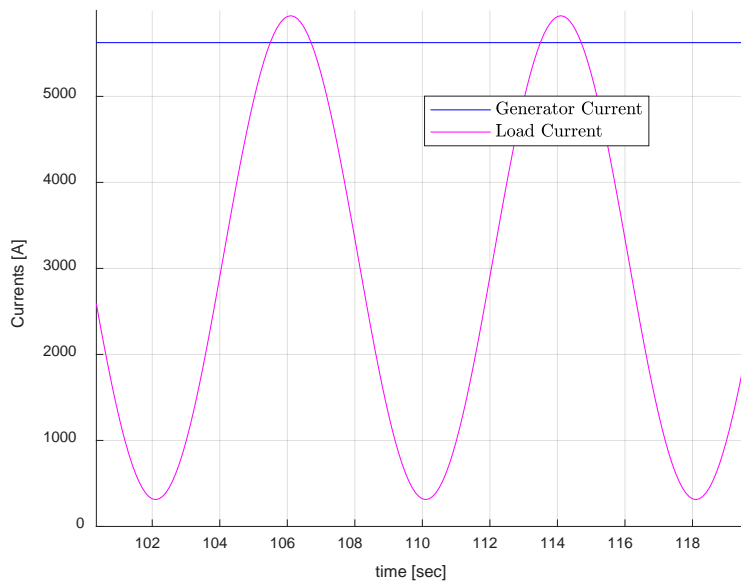

Figure 29. Heavy Sea Hybrid Currents at 90% of the Generators' Power

In this situation the choice of running the generators at a constant 50% of rated load is still a good option. In Figure 30 the current of the generators is at 50% of the peak load currents. The efficiency drops a little when compared to non-hybrid mode from 18.6% to 17.9%. However, the fuel consumption is improved because in non-hybrid mode the generators operate in a more inefficient part of the quadratic fuel consumption curve from Figure 5. In a heavy storm in non-hybrid mode, the fuel consumption is 403.5 gal/hr while in hybrid mode, the fuel consumption is 387 gal/hr.

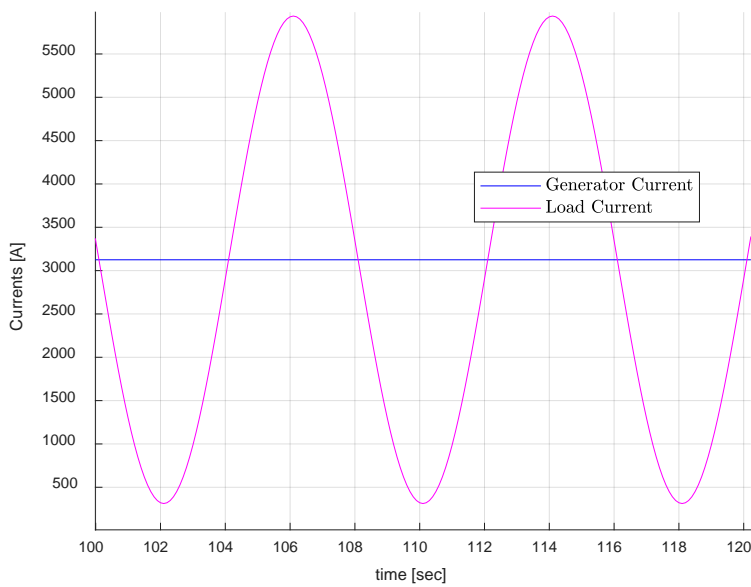

Figure 30. Heavy Sea Hybrid Currents at 50% of the Generators' Power

In a heavy storm scenario there is one more configuration that improves fuel consumption with almost a two-fold reduction. If only one generator is turned on and operating at 95 % rated load, instead of running two generators, the overall fuel efficiency is increased. For this to work, the engine load control would need to lower the generator speed slightly and would result in a slightly slower ship. The load control of the generators would need to be lowered because the ESS will be providing more power than the generator and eventually the batteries will be completely discharged with the SOC dropping about 14% per hour. By lowering the average load demand from 50% to about 47.5% of the system, one generator can operate at 95% rated load and the ESS can maintain a constant average SOC on the batteries. The currents with and without SCs are compared in Figure 31 and the battery SOC comparison is shown in Figure 32.

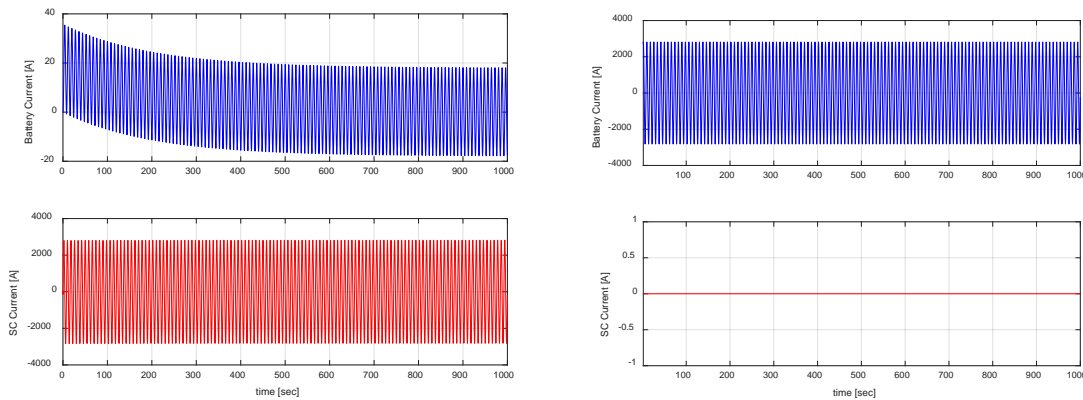

Figure 31. Heavy Seas with One Generator Operation SC Comparison

The SC comparison plot in Figure 31 is similar to the previous SC comparison plots but shows the ESS being utilized more because of the higher peak load. The plots presented in Figure 32 demonstrate that, when SCs are part of the ESS, the SOC of the batteries reach steady state while, if the system does not have the SCs, the battery SOC declines linearly. Without the SCs the battery cannot keep up with the power demand, and will eventually discharge completely.

Finally, when utilizing one generator in heavy seas at 95% rated load, the efficiency of that generator is 35.27% and the fuel consumption is 186.74 gal/hr. In this hybrid configuration, utilizing the ESS fully, and running one generator instead of two, the system efficiency is greatly improved, and the fuel consumption is reduced by over 50% with almost the same system power output. This is because now only fuel is consumed by one prime mover instead of two prime movers and the ESS provides the power needed that would have been produced by the second prime mover if it was in operation.

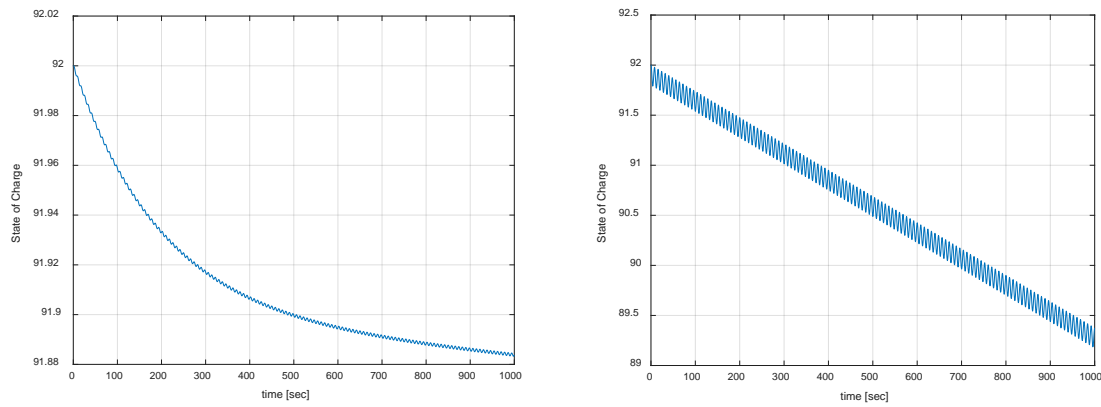

Figure 32. Heavy Load SOC Comparison of SC Use on One Generator

THIS PAGE INTENTIONALLY LEFT BLANK

V. CONCLUSIONS AND FUTURE WORK

This chapter presents conclusions based on the results of this research into energy storage devices integrated with a vessel diesel-electric propulsion system. Future work is recommended, including the study of the vessel's EMS controller, optimization and experimental verification.

A. CONCLUSIONS

The goal of this thesis was to research the benefits of adding energy storage devices to a vessel's propulsion system. Energy storage devices in the form of Li-Ion batteries and SCs, when integrated with a vessel propulsion system, provide numerous advantages. In addition to an ESS being a reserve power storage system, batteries and SCs can reduce fuel consumption and engine maintenance. Fuel consumption is reduced by keeping the diesel generators at an optimal loading condition and utilizing the ESS at lower, less efficient loads. Maintenance can be reduced because the ESS is sharing the load demand with the generators. Therefore, the generators are not under the stress they would be without the ESS. This leads to more time between scheduled maintenance periods and unexpected breakdowns. Lastly, an environmental benefit is achieved when the engines of the generators operate at the most efficient speed with the aid of the ESS and less fuel is burned, thus less pollution from the engine exhaust.

The simulation results presented in this thesis demonstrate that in hybrid mode, fuel consumption was lower in almost every load setting. Under light loads, the ESS was utilized the least because the generators were able to run at a high optimal speed which did not produce much excess energy for charging and discharging the batteries. If the ESS was to share the load evenly with the generators, then there is an efficiency drop of 0.01%. However, if the generators run at a higher load setting, the efficiency is higher and the excess power produced has to be utilized in other vessel loads such as engine room loads or hotel service loads. This remains true for all sea conditions. During moderate sea conditions the batteries and SCs were utilized well. If the generators evenly shares the load with the batteries and SCs the efficiency remains the same as in the non-hybrid mode but,

the fuel consumption drops by 5.3 gal/hr to 372.2 gal/hr. Finally, during heavy sea conditions the potential for fuel savings is the greatest. In heavy sea conditions the load varies widely and the efficiencies of the generators are the lowest. However, with the batteries and SCs acting as a second generator, then one of the diesel generators can be shut down as explained at the end of Section B.3. With only one generator running and with the ESS fully utilized, the fuel consumption is reduced by about 50%. On the other hand, when the load during high sea conditions evenly is shared by the two generators and the ESS, the efficiency actually drops from 18.6% to 17.9 % when compared to non-hybrid mode operation.

Another observation when comparing the battery currents with and without SCs, is that the battery currents without the SCs in the ESS exceed the C-Rate, which is unacceptable. As mentioned before, the batteries for this simulation have a C-Rate of 6C. With the batteries having a 125 Ah rating, the maximum charge rate without doing damage to the batteries is 750 Amps in 10 minutes. The charging current without the SCs far exceeds this and a different type of control would need to be developed to compensate for the over current. However, with the SCs included in the ESS, the current of the batteries remains well within acceptable C-Rate limits while charging and discharging.

B. FUTURE WORK

There are several areas of future research remaining that can be pursued in relation to this thesis. One area to explore would be to look at different load profiles for the main propulsion. For example, during low propulsion loads on the ship, such as when a vessel is maneuvering in and out of port at low speeds, or for sudden changes in engine direction when docking a ship. Also, to record ocean wave behavior, data from a sea buoy or an active ship could be collected and used in the load simulation profile.

The load profile could also be optimized to show where the most fuel savings would be. Also, a different control method could be developed that is closer to what is happening on an actual ship. In addition, there are other electric ship loads that could be simulated. For example, the engine room loads such as the motors connected to pumps, fans and other rotating equipment could be simulated. Hotel loads could also be simulated including the

galley and air conditioning systems. Lastly, loads that deal with other electrical equipment can be simulated such as weapons system, namely the U.S. Navy electromagnetic rail gun, or cargo operation loads like electric cranes and cargo pumps.

Lastly, additional studies could explore how SCs increase the battery life in the ESS since the SCs help in limiting the amount and number of discharges by the batteries. Another study could look at SCs in a hybrid ESS that does not include batteries as part of the system. Lastly, an experimental test could be conducted on a large or small scale. SCs could be integrated into a model of a ship or could be tested in a limited and preliminary capacity aboard a sailing ship or docked ship.

THIS PAGE INTENTIONALLY BLANK

APPENDIX. MATLAB SCRIPTS

```
clear all; close all;
t = 0:1:999;%t = 0:1:999
tstop = 100;%100
timegen = (1:1000)'/10; %timegen = (1:1000)'/10;

%%
hybrid_switch=1;%value of 1 turns on hybrid pwr, zero turns off
hybrid_var_switch= 1;% hybrid ops w/out generator changes, (set value
to one)
vary = 1; %Tells how much to vary gen in hybrid mode (adjust SOC
constant as well) (one for normal ops)

%gen_pwr=4250000;%avg pwr demand of 85%
%load_var = 500000;%Variation in load from waves at 10%

%gen_pwr=3500000;%avg pwr demand of 70%
%load_var = 1250000;%Variation in load from waves 25%

gen_pwr=2500000;%avg pwr demand of 50%
load_var = 2250000;%Variation in load from waves 45 %

%gen_pwr=5000000*.5;%avg pwr demand of 50%
%load_var = 2250000;%Variation in load from waves 45 %

load2= (gen_pwr + (load_var)*sin((2*pi/8/10)*t));%keep max load to <95%

power_load = load2;

tstep = .001;
Hybrid_pwr = 5000000*.51;%Generator pwr at 90% in hybrid mode

Kp=4;%4
Ki=40;%40
Cap=0.125;% If too big model or small becomes unstable
Csc=250*4 ; %supercapacitors,130 by 4 by 250x(increase by
250x)250x100x4if too low the system not be able to keep up
alpha=0.005; %determines amount of energy to batteries's (0.002) (Low #
makes
%batt's take less load)If to big model gets singularity. good at 0.005
V_dc_ic = 800;%Originally 200 volts, increased to drop current

V_battery = 800;%800; % battery string voltage 12x10x4
A_hours = 125; % rated battery amp hours rated at 1kWh(similar to
Corvus set-up) original =12Ah (Rated kWh / V_battery)
num_strings = 8; %8 % number of battery strings in parallel (High
number keeps SOC from railing to high)8x4
E_battery = num_strings*V_battery*A_hours*60^2; % watt seconds =J (gain
block 6 for SOC)
```

```

Vmax = 820;% plus/minus 20 volts
Vmin = 80;%780
Emax= 1/2*Csc*Vmax^2;
Emin= 1/2*Csc*Vmin^2;
V_sc_ic = sqrt(2/Csc*(Emax+Emin)/2); % set to voltage where half the
%energy is available for charging and half for discharging

Batt_i = hybrid_switch;%charge from batteries, change to 0 for no batt
pwr
SOC = hybrid_switch;%zero for no SOC, disables hybrid operation
SC_i = hybrid_switch;%SC current out

% break2 = Vmax-V_sc_ic;
% break3 = Vmin-V_sc_ic;
% breakd = 3; % controller band from zero gain to unity gain
% pts1 = breakd/(Vmax-Vmin)*2000;
% pts2 = 2000-pts1;
% for ii = 1:2000
%     x_data(ii) = break3+ (ii-1)/1999*(Vmax-Vmin);
%     if x_data(ii) < break3+breakd
%         y_data(ii) = (ii-1)/pts1;
%     elseif x_data(ii) <= break2-breakd
%         y_data(ii) = 1;
%     else
%         y_data(ii) = 1-(ii-pts2)/pts1;
%     end
% end

%%
SC_on=1;
sim ship_simulation_Apr2;
timev = simout1(:,4);
Ibat_SCON = simout1(:,1);
vsc_SCON = simout1(:,8);
isc_boost_SCON = simout1(:,3);
avg_battery_I_with_SC = mean(Ibat_SCON);
avg_SC_I = mean(isc_boost_SCON);
sc_peaktpeak= max(vsc_SCON)-min(vsc_SCON);
vdc_bus_SCON = simout1(:,2);
%gain_var = simout1(:,7); used for controller bypass, last used on Mar
14th
%model
pgen = simout(:,1);%Gen pwr out
pwrgen=(pgen/50000);%pwr gen in percent
fuel_cons= (0.017536.*pwrgen.^2 - 2.8432.*pwrgen + 485.32);%g/kWh fuel
consumption using equation for 2 gens
kWh_per_g = pgen./1000./fuel_cons;%kWh/g
Eff = 100*(kWh_per_g/36.0679635);%Fuel Efficiency

figure(1)

grid on;
xlim([2 inf]);
ylim([-20 40]);

```

```

ax = gca;
%ax.XTick = [0,4,8,12,16,20,24];
%ax.YTick = [-20,0,20,40];
hold on
plot(timev,simout1(:,6),'b');
grid on;
xlim([2 inf]);
%ylim([0 6000]);
ax = gca;
%ax.XTick = [0,4,8,12,16,20,24];
%ax.YTick = [-20,0,20,40];
%plot(timev,simout1(:,7),'g'); for second generator
%plot(timev,-simout1(:,10),'g'); %for second load,load 1
grid;
xlim([2 inf]);%([0 24])
%ylim([-20 60]);
ax = gca;
%ax.XTick = [0,4,8,12,16,20,24];
%ax.YTick = [-20,0,20,40,60];
plot(timev,-simout1(:,5),'m');
xlabel('time [sec]');
ylabel('Currents [A]')
grid;
xlim([2 inf]);
%ylim([0 80]);
ax = gca;
%ax.XTick = [0,4,8,12,16,20,24];
%ax.YTick = [0,20,40,60,80];
legend('Generator Current' , 'Load
Current','interpreter','latex','location','best');%i_secondary load'
hold off
%print(gcf,'-djpeg','-r350','Figure3rev');

figure(2)
subplot(2,1,1), plot(timev,Ibat_SCON,'b');
ylabel('Battery Current [A]')
grid;
%xlim([0 100]);
%ylim([-40 40]);
ax = gca;
%ax.XTick = [0,4,8,12,16,20,24];
%ax.YTick = [-40,-20,0,20,40];
subplot(2,1,2), plot(timev,isc_boost_SCON,'r');
ylabel('SC Current [A]')
grid;
%xlim([0 100]);
%ylim([-40 40]);
ax = gca;
%ax.XTick = [0,4,8,12,16,20,24];
%ax.YTick = [-40,-20,0,20,40];
xlabel('time [sec]');
%ax.YTick = [-1,-0.5,0,0.5,1];

figure(3)
subplot(2,1,1), plot(timev,isc_boost_SCON),'r';

```

```

hold on;
subplot(2,1,1), plot(timev,vsc_SCON-V_sc_ic,'g');%difference btwn
Actual voltage and control coltage
hold off;
legend('SC Current','v SC - v
SC*','interpreter','latex','location','southeast');
grid;
%xlim([0 100]);
%ylim([-40, 40]);
ax = gca;
%ax.XTick = [0,4,8,12,16,20,24];
%subplot(2,1,2), plot(timev,gain_var,'b');
%ylim([0 1.5])
legend('SC current gain','interpreter','latex','location','northwest');
grid;
%xlim([0 100]);
xlabel('time [sec]');
ax = gca;
%ax.XTick = [0,4,8,12,16,20,24];

figure(4)
plot(timev,isc_boost_SCON,'r');
hold on;
plot(timev,vsc_SCON-V_sc_ic,'g');
%plot(timev,gain_var*10,'b');%gain times 10 for visability
%ylim([-30 30])
grid;
xlim([2 inf]);
%ylim([-40, 40]);
xlabel('time [sec]');
ax = gca;
%ax.XTick = [0,4,8,12,16,20,24];
legend('i SC','v SC-v SC*','SC current
gain','interpreter','latex','location','southeast');
hold off;

figure(8)%SOC
plot(timev,simout(:,2))
xlabel('time [sec]')
ylabel('State of Charge')
grid
%xlim([0 24]);

figure(9)
subplot(3,1,1),plot(timev,fuel_cons)
grid
xlim([8 inf])
legend('Fuel Consumption')
xlabel('time [sec]');
ylabel('Gal/hr');
hold on
subplot(3,1,2),plot(timev, kWh_per_g)
grid
xlim([8 inf])
xlabel('time [sec]');

```

```

ylabel('kWh/gal')
hold on
subplot(3,1,3),plot(timev,Eff)
grid
xlim([5 inf])
legend('Efficiency')
xlabel('time [sec]');
ylabel('Percent %')
hold off

%%
SC_on=0;
sim ship_simulation_Apr2;
vdc_bus_SCOFF = simout1(:,2);
Ibat_SCOFF = simout1(:,1);
vsc_SCOFF = simout1(:,8);
isc_boost_SCOFF = simout1(:,3);

figure(5)
subplot(2,1,1), plot(timev,simout1(:,1),'b');
%legend('i_B','interpreter','latex','location','best');
ylabel('Battery Current [A]')
grid;
xlim([2 inf]);
%ylim([-40 40]);
ax = gca;
%ax.XTick = [0,4,8,12,16,20,24];
%ax.YTick = [-40,-20,0,20,40];
subplot(2,1,2), plot(timev,isc_boost_SCOFF,'r');
grid;
xlim([2 inf]);
%ylim([-40 40]);
ax = gca;
%ax.XTick = [0,4,8,12,16,20,24];
ylabel('SC Current [A]');
xlabel('time [sec]');
avg_battery_I_without_SC = mean(simout1(:,1));

figure(6)
subplot(2,1,1), plot(timev,vdc_bus_SCON-V_dc_ic,'b');
ylabel('DC bus ripple SC on [V]')
grid;
xlim([2 inf]);
%ylim([-25 25]);
ax = gca;
%ax.XTick = [0,4,8,12,16,20,24];
%ax.YTick = [-20,-10,0,10,20];
subplot(2,1,2), plot(timev,vdc_bus_SCOFF-V_dc_ic,'r');
ylabel('DC bus ripple SC off [V]')
xlabel('time [sec]');
grid;
xlim([2 inf]);

```

```
%ylim([-25 25]);  
ax = gca;  
%ax.XTick = [0,4,8,12,16,20,24];  
%ax.YTick = [-20,-10,0,10,20];  
  
figure(7)%SOC  
plot(timev,simout(:,2))  
xlabel('time [sec]')  
ylabel('State of Charge')  
grid  
%xlim([0 24]);
```

LIST OF REFERENCES

- [1] American Bureau of Shipping, “ABS advisory on hybrid electric systems,” May 2019. [Online]. Available: https://ww2.eagle.org/content/dam/eagle/advisories-and-debriefs/ABS_Hybrid_Advisory_17033.pdf
- [2] Marine Log, “All American Marine launches hybrid tour boat for Red and White Fleet,” August 24, 2018. [Online]. Available: <https://www.marinelog.com/coastal/ferries/all-american-marine-launches-hybrid-battery-tour-boat-for-red-and-white-fleet/>
- [3] Wärtsilä, “Wärtsilä makes Viking Princess the world’s first offshore vessel with a hybrid energy storage solution replacing a traditional generator,” October 13, 2017. [Online]. Available: <https://www.wartsila.com/media/news/13-10-2017-wartsila-makes-viking-princess-the-worlds-first-offshore-vessel-with-a-hybrid-energy-storage-solution-replacing-a-traditional-generator>
- [4] American Bureau of Shipping, “Guide for use of supercapacitors in the marine and offshore industries,” Houston, TX, USA, Dec. 2017. [Online]. Available: https://ww2.eagle.org/content/dam/eagle/rules-and-guides/current/other/288_supercapacitors_2017/Supercapacitors_Guide_e-Dec17.pdf
- [5] G. Castles, G. Reed, R. Pitch, and A. Bendre, “Economic benefits of hybrid drive propulsion for naval ships,” *IEEE Electric Ship Technologies Symposium*, pp. 515–520, Apr. 2009.
- [6] Eidesvik. “Viking Princess.” Accessed December 3, 2018. [Online]. Available: <https://www.eidesvik.no/viking-princess/category505.html>
- [7] Tecate Group. “Ultracapacitor & supercapacitor frequently asked questions,” May 7, 2019. [Online] Available: <https://www.tecategroup.com/ultracapacitors-supercapacitors/ultracapacitor-FAQ.php>
- [8] G. Oriti, A.L. Julian, N. Anglani, G. Hernandez, “Novel Economic analysis to design the energy storage control system of a remote islanded microgrid” *IEEE Trans. on Industry Applications*, vol. 54, no.6, Nov/Dec 2018, pp. 6332–6342.
- [9] B. Zahedi, “Shipboard DC hybrid power systems,” Ph.D. diss., Dept. of Elec. Eng, NTNU, Trondheim, Norway, 2014.
- [10] K. Kim, K. Park, G. Roh and K. Chun, “DC-grid system for ships: a study of benefits and technical considerations,” *Journal of International Maritime Safety, Environmental Affairs, and Shipping*, vol. 2, no. 1, pp. 1–12, Aug. 2018. [Online]. doi: 10.1080/25725084.2018.1490239

- [11] All Hands, Magazine of the U.S. Navy. “USS Zumwalt,” May 7, 2019. [Online]. Available: https://www.navy.mil/ah_online/zumwalt/
- [12] G. Oriti, A. L. Julian, and N. J. Peck, “Power-electronics-based energy management system with storage,” *IEEE Trans. Power Electron.*, vol. 31, no. 1, pp. 452–460, Jan. 2016.
- [13] R.D. Geertsma, R.R. Negenborn, K. Visser, and J.J. Hopman, “Design and control of hybrid power and propulsion systems for smart ships: a review of developments,” *Applied Energy*, vol. 194 no.1, pp. 30-54, May 2017. [Online]. doi: 10.1016/j.apenergy.2017.02.060
- [14] W. Chen, A. K. Ådnanses¹, J. F. Hansen¹, J. O. Lindtjørn¹ and T. Tang. “Super-Capacitors based hybrid converter in marine electric propulsion system,” XIX International Conference on Electrical Machines - ICEM 2010, Rome, Sep. 2010.
- [15] W. P. Symington, A. Belle, H. D. Nguyen, and J. R. Binns, “Emerging technologies in marine electric propulsion,” *J Engineering for the Maritime Environment*, vol. 230, no. 1, 2016, pp. 187–198.
- [16] V. Shagar, S. G. Jayasinghe, and H. Enshaei, “Effect of load changes on hybrid shipboard power systems and energy storage as a potential Solution: a review,” *MDPI – Inventions*, August 28, 2017. [Online]. Available: <https://doi.org/10.3390/inventions2030021>
- [17] CORVUS. “Orca ESS Solutions,” December 10, 2018. [Online]. Available: https://corvusenergy.com/wp-content/uploads/2016/09/Orca_Energy_Spec.pdf
- [18] MIT Electric Vehicle Team. “A guide to understanding battery specifications,” May 7, 2019. [Online] Available: http://web.mit.edu/evt/summary_battery_specifications.pdf
- [19] G. Oriti, A. Julian, N. Anglani, “Hybrid Energy Storage Control in a Remote Military Microgrid with Improved Supercapacitor Utilization and Sensitivity Analysis” in *Proc. of IEEE 10th Energy Conversion Congress and Expo (ECCE)* 2018, Portland, OR, September 23–27, 2018.
- [20] Military Standard 633G, Department of Defense Interface Standard - Standard Family of Mobile Electric Power Generating Sources -General Description Information and Characteristic Data, 30 May 2013.
- [21] Wartsilacorp. “Wärtsilä’s hybrid energy solutions on board Viking Princess,” YouTube, October 12, 2017. [Online]. Available: <https://www.youtube.com/watch?v=Gf2AAP93Kfw>

INITIAL DISTRIBUTION LIST

1. Defense Technical Information Center
Ft. Belvoir, Virginia
2. Dudley Knox Library
Naval Postgraduate School
Monterey, California