



Calhoun: The NPS Institutional Archive
DSpace Repository

NPS Scholarship

Publications

2019

Modeling and Simulation Informed Conceptual Design, Analysis, and Initial Component Selection of a Supply-Side Building Scale LAES System for Renewable, Islanded Microgrid Resiliency

Girouard, Christopher; Pollman, Anthony G.; Hernandez, Alejandro
Military Operations Research Society (MORS)

Girouard, Christopher, Anthony G. Pollman, and Alejandro Hernandez. "Modeling and Simulation Informed Conceptual Design, Analysis, and Initial Component Selection of a Supply-Side Building Scale LAES System for Renewable, Islanded Microgrid Resiliency." MORS Symposium (2019)

<https://hdl.handle.net/10945/65186>

This publication is a work of the U.S. Government as defined in Title 17, United



Calhoun is the Naval Postgraduate School's public access digital repository for research materials and institutional publications created by the NPS community. Calhoun is named for Professor of Mathematics Guy K. Calhoun, NPS's first appointed -- and published -- scholarly author.

Dudley Knox Library / Naval Postgraduate School
411 Dyer Road / 1 University Circle
Monterey, California USA 93943

<http://www.nps.edu/library>

MODELING AND SIMULATION INFORMED CONCEPTUAL DESIGN, ANALYSIS, AND INITIAL COMPONENT SELECTION OF A SUPPLY-SIDE BUILDING SCALE LAES SYSTEM FOR RENEWABLE, ISLANDED MICROGRID RESILIENCY

Christopher M. Girouard, Anthony G. Pollman, Alejandro Hernandez

Graduate School of Engineering and Applied Sciences, Naval Postgraduate School, Monterey CA

Abstract:

Effective use and integration of renewable energy sources, coupled with different storage options, is an emerging priority within the Department of Defense. One promising method of energy storage is a Liquid Air Energy Storage system (LAES), which uses renewable energy in excess of immediate demand to make and cryogenically store liquid air for later expansion through a turbine to generate power when needed. This paper outlines a modeling and simulation approach to determining the design and material specifications based on a supply requirement of a renewable energy fed LAES. The source power requirement was based on the available renewable generation at the Naval Postgraduate School (NPS) Turbo-Propulsion Laboratory of 18 kW. These models revised previous validated versions, which were used to design a small-scale theoretical LAES system, to yield an integrated, practical, building-scale simulation. The expansion and generation portion of a LAES system was simulated for a Linde-Hampson cycle using the process modeling software Aspen HYSYS. The results from this model, along with a demand side analysis, will be used to map the trade space of a LAES system and determine potential commercial components for system construction. This work is part of a larger effort to determine the effectiveness of potential energy storage solutions for naval facilities or Forward Operating Bases (FOB).

1. Introduction

Energy is the single largest component of naval installation budgets, accounting for 28% of total operational costs (United States Navy 2019). Through both shipboard and shore-based operations, the U.S. Navy consumed nearly 45 million barrels of petroleum in 2008 (United States Navy 2010). To reduce this fossil fuel demand and related operational costs, the Navy aims to get 50% of its total energy needs from renewable sources by 2020. In working toward this and other aggressive goals put forth by the Secretary of the Navy in 2009, the Navy is committed to decreasing dependence on petroleum and its associated logistical and environmental complications (Chief of Naval Operations 2009). Naval installations are an ideal starting point for working toward these goals. Installations are typically large and permanent, allowing for implementation of more complex and sophisticated technologies for energy production and storage. By using such systems, naval installations can increase operational efficiency and decrease reliance on the electrical grid and non-renewable sources, thereby enhancing operational resiliency ashore or operational reach in the field (Pollman 2013).

2. Background

Large scale power production systems and smaller microgrids are increasingly dependent on renewable sources for generation of power. However, these sources are intermittent and lack the stability of non-renewable sources while requiring additional infrastructure to ensure constant energy flow. There are a variety of methods currently used to store energy though each has their own advantages and limitations. These technologies and their limitations are summarized in Table 1. For example, pumped hydro storage requires two reservoirs and an elevation change, so the technology application would be constrained by geography and not be suitable for a movable military microgrid in support of mobile military operations.

Table 1: Energy Storage Methods Summary (Adapted from (McLarnon and Cairns 1989))

Storage Method	Advantage	Disadvantage
Hydro Storage	Increased load flexibility, high power capacity	Large space required, geographically constrained
Batteries	Widely available, low energy loss	Heavy, thermal sensitivity, limited cycles, rely on rare metals
Flywheels	Fast discharge/recharge times	Expensive, high energy loss
Thermal	Low cost, efficient	Significant infrastructure, typically for heating/cooling (not power)
Compressed Air	High energy density	Large space required, may be geographically constrained, high cost if using large tanks
Magnetic	Efficient	Expensive, significant infrastructure

One promising technology is Liquid Air Energy Storage (LAES), in which excess energy is used to cool and cryogenically store air. When that energy is needed, the liquid air is expanded and turns a turbine to generate power. While having the advantages of hydro and compressed air, it is not geographically constrained or require large tanks. The first large-scale operational plant of this type was recently of this type opened in 2016 at the University of Birmingham, UK, and uses waste heat from a nearby landfill-gas powered generation facility to improve overall efficiency (Kitanovski et al. 2016). Figure 1 is a schematic representation of the Highview facility at the University of Birmingham and highlights the major components of a LAES system.

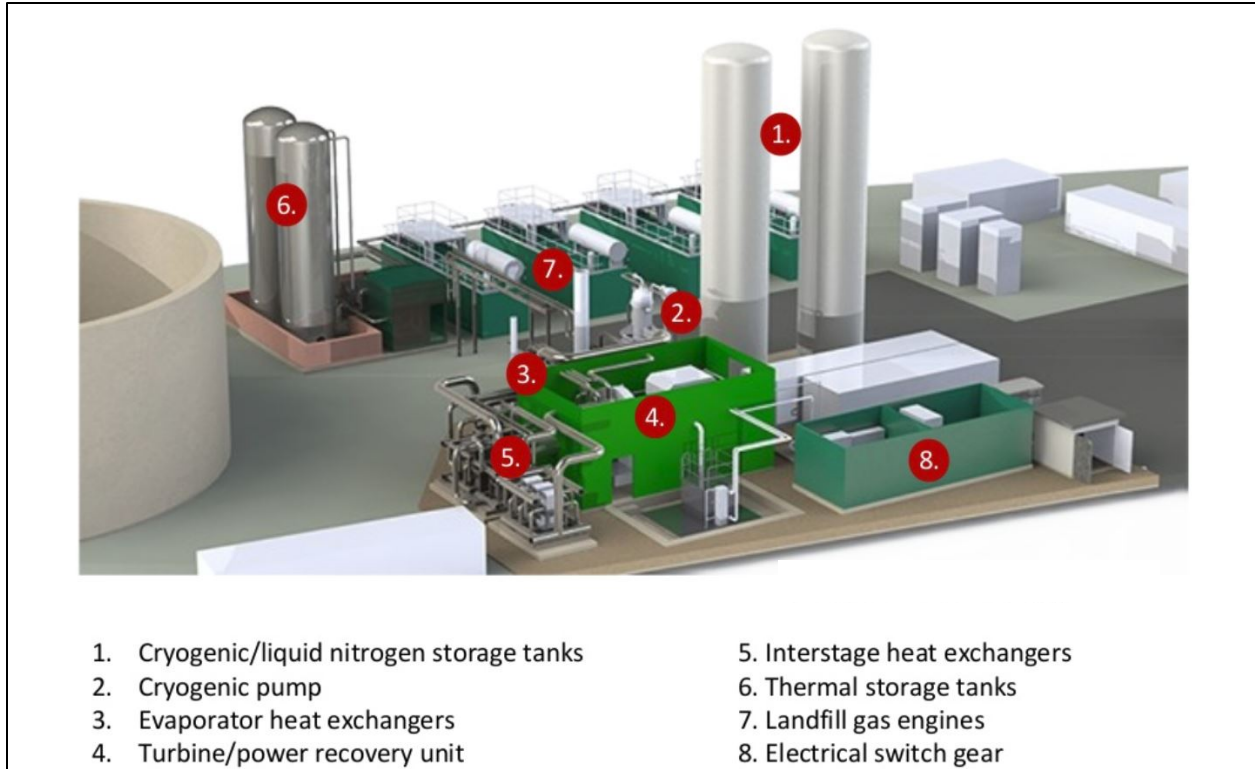

Figure 1: Highview's LAES showing major components of the system (Adapted from Riley 2015. Used with permission)

Large scale in-service LAES systems claim a high overall efficiency. For example, the Highview LAES plant claims 60% standalone efficiencies with potential improvement when utilizing further integration into existing co-located industrial infrastructure (Highview Power Storage 2017). However, this significant efficiency savings must be balanced against the requirements for a highly complex, large scale plant with years of design planning and process improvement.

LAES systems require a significant amount of energy relative to their storage capacity due to the equipment needed for the compression and expansion cycles. This type of system shows promise when co-located with waste heat or cooling recovery from other commercial processes. However, further studies and tools are needed to assess feasibility and aid in the design of systems for a given requirement set.

This paper investigates the design requirements and capability of a LAES system developed for a specified energy input capacity as well as the component selection for the design. The Naval Postgraduate School (NPS) Turbo-Propulsion Laboratory (TPL) is equipped with a total of 18kW mixed wind and solar power generation. The generated power is supplied to a microgrid currently using batteries and super capacitors for energy storage. Because the microgrid is designed to be modular and support experimentation, the TPL is a suitable location for pilot infrastructure development and testing.

The present work is based on prior work done at NPS on the thermodynamics, specifications, and modeling of LAES systems. Most of this work was at the theoretical level developing the ideal pressures, temperatures, and heat exchangers for a small-scale prototype (T. Howe 2018). This evolved into the development and validation of a modeling and simulation tool (Willis 2018) as well as the construction of the cryogenic side of a prototype at the TPL (Amalla, Pollman, and Hernandez, n.d.). The prototype is currently under development, but the modeling tool is integral to the design and construction of a potential building-scale system at NPS. Additionally, this work is in conjunction with a demand-side LAES design study determining the system requirements for a specific energy demand (Bailey, Pollman, and Paulo 2019).

LAES systems have two subsystems: the compression side and the expansion side. Figure 2 shows a basic schematic of a generic LAES system. On the compression side, ambient air (1) is fed into a compressor, which pushes hot high-pressure air (2) to a compression heat exchanger. The heat exchanger cools the compressed air, which is then fed (3) to the JT valve where it is expanded to produce liquefied air. The liquefied air (4) is stored in the cryogenic liquid reservoir (dewar). Any air that is not liquefied is recycled (5) back to the compressor. When energy is required, the liquid is pumped out of the reservoir (6), heated on the expansion side through a heat exchanger (7), and expanded to spin a turbine (8). The turbine drives a connected generator to produce electricity (9). The compression and expansion sides are isolated by control valves and never operate at the same time.

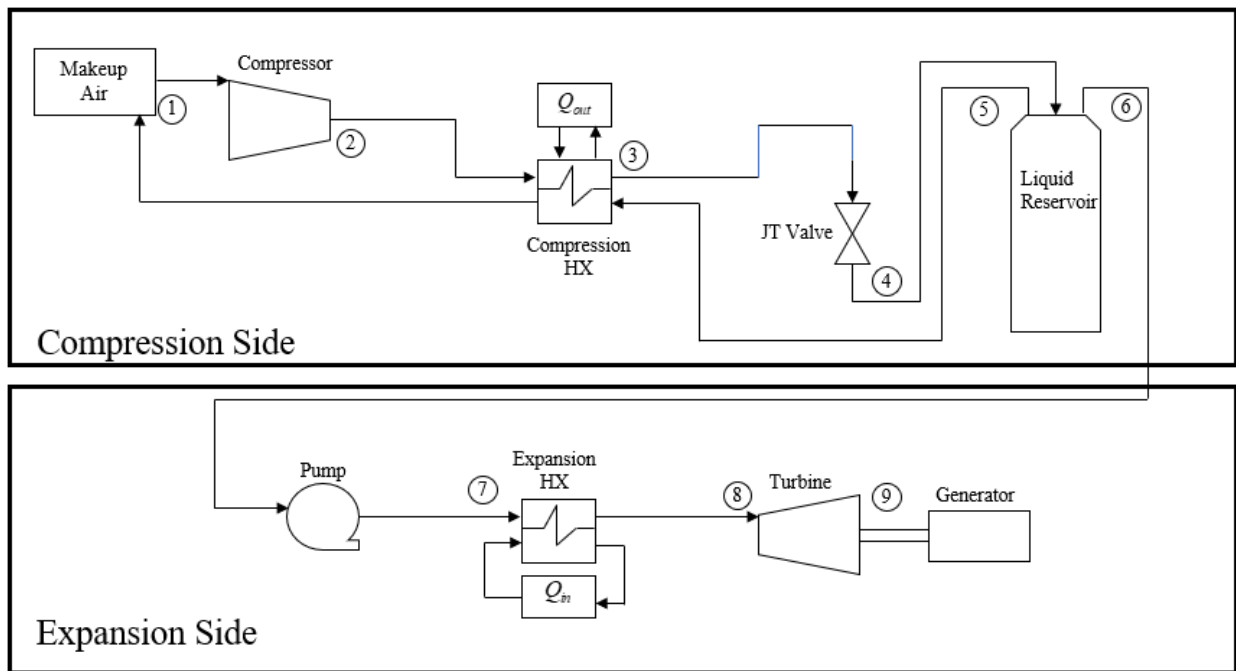

Figure 2: System Diagram of LAES System (Adapted from (T. A. Howe, Pollman, and Gannon 2018). Used with permission)

3. Modeling and Simulation of Conceptual LAES Design

The present work was performed using the Aspen HYSYS simulation program. This program is commonly used to model, simulate, and analyze operational concepts and energy flow in complex processes. It allows the control of temperatures, materials, pressures, and component specification. In this investigation, this program allowed the physical representation of theoretical thermodynamics and provided verification of the calculated parameters from previous work, as well as the ability to expand and design a system to fit a specific need. The present work generated a model of a LAES system based on the following constraints: input energy under 18kW, sized to fit within the existing NPS lab (less than 20 ft^2), store 5kWh of energy to produce electricity to power lights and computers, assume realistic nominal efficiencies and input power, and to use the same process as the previously validated model (Willis 2018).

These stages were broken up in the model to both match real multistage systems and to allow for Aspen HYSYS to appropriately model the process. Figure 3 shows the Aspen HYSYS model split between the compression and expansion sides, following the function of Figure 2.

This model assumed that the renewable energy sources produce 18kW, which is the maximum rated capacity for the currently installed, renewable generators at the NPS TPL. The Monterey area, however, has significantly lower averages of both average wind speed and solar irradiance than other areas of California (National Renewable Energy Laboratory 2010, Roberts 2018). It is therefore unlikely that these generators operate at maximum capacity, meaning the TPLLAES system would not receive a full 18kW input power in practice. This model also did not account for any power backups or automatic switches that would be required to reduce the possibility of damages due to power fluctuation. The advertised efficiencies of specific components were also assumed to be correct even though additional losses would likely occur due to insulation, transmission, and excess heat transfer in the system. Such losses were not represented in this model, so the system would perform less efficiently in practice than simulation. Thus, the simulation produces a best-case scenario.

In addition to these assumptions, this model neglected the power required to operate pumps on the expansion side of the system concurrently with cryogenic liquid generation. Under normal intended operation, the compression side would only be charging when excess energy is *not* needed, then the expansion side would only operate when it *is*.

The model was used to examine the performance parameters of key components affecting output. Establishing these upfront helped to reduce the scope and number of changing variables, allowing for a simpler approach and reduced variability in the output. In addition, this simplification ensured adequate resolution and realism in the final component selection. Case studies using Aspen HYSYS focused on the rate of liquid air production rather than total power output. This allows use of Howe's (2018) fundamental comparison. The liquid storage tank sizing and the expansion and turbine side of the system were left open-ended initially, to be designed later to meet specific power requirements. Variables tested include adjusting temperatures, number of stages, mass flow rate, compressor pressures, and vaporizer heat input. These case study simulations showed mass flow rate and compressor pressure to be the two most important factors affecting the liquid air output.

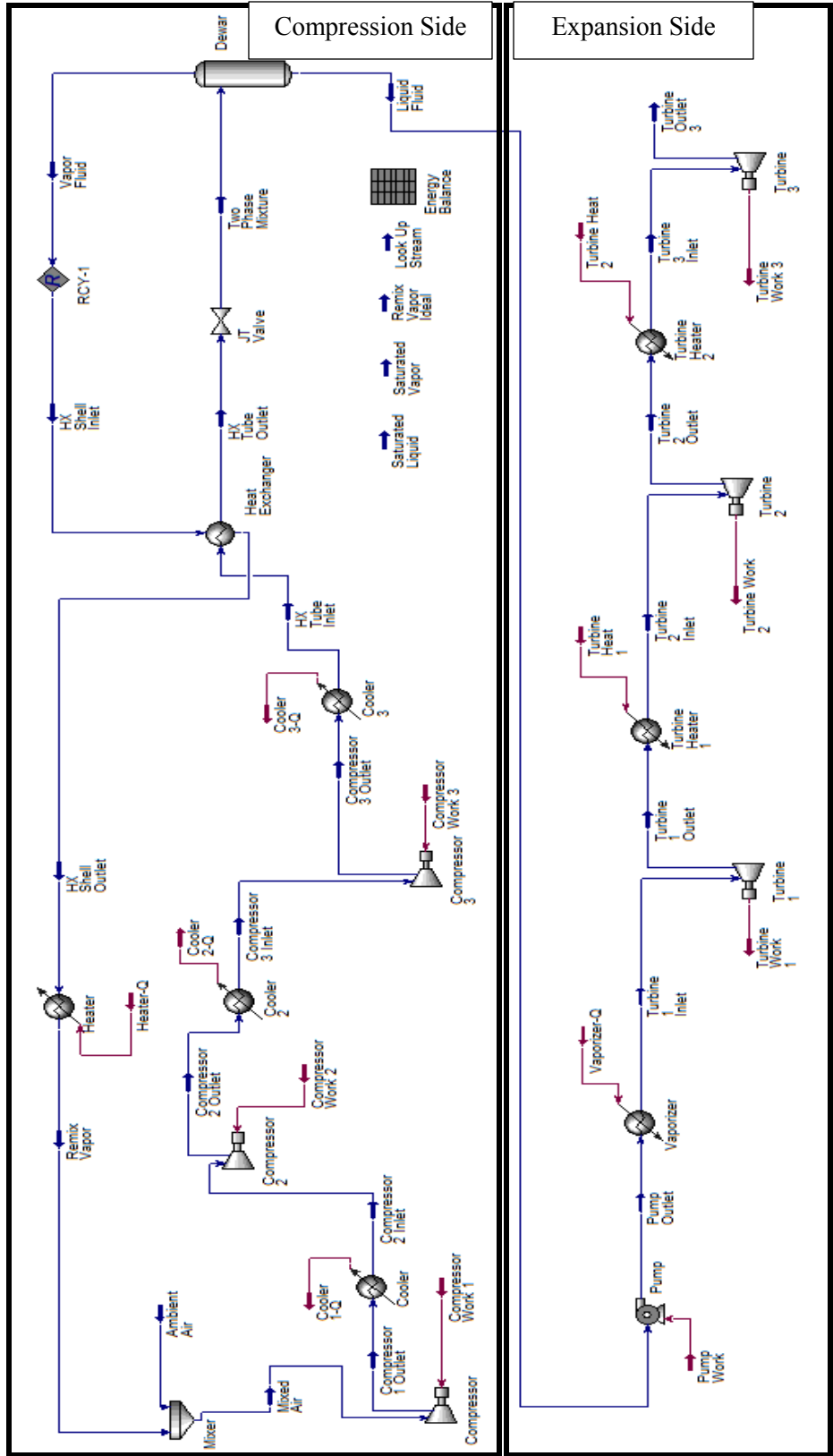

Figure 3: Aspen HYSYS Model showing major system components and process

4. Analysis and Results

The interaction of mass flow rates and pressure ratios on total liquid air production was studied using factor analysis. Factor analysis uses a statistical approach to determine the cause and effect relationships between different variables. This allows for the determination of the key variables in a function and confines the analysis to the most important factors. Factor analysis was conducted using air mass flowrates of 1-100 kg/h, and pressure ratios of 5.9-7.0 which correspond to the three-stage setup of the model with output pressures of 3000-6000 psi. These output pressures are within the range of Howe’s estimate of best performing output pressures (2900-7200 psi).

Figure 4 is a Pareto chart of estimates produced by the statistical analysis program, JMP. The greater the t-ratio, the greater the effect on the output on the system. This analysis determined that air flowrate of the compressor is the most important factor affecting total liquid air production. Based on that information, decisions were made between available compressors of known air flowrates and pressure ratios, with preference given to those with higher flowrates over those with higher pressure ratios.



Term	t Ratio	
Air Flow Rate (CFM)	1241.1930	
Compressor - Pressure Ratio	186.0485	
(Air Flow Rate (CFM)-50.5)*(Compressor - Pressure Ratio-6.45)	106.3477	

Figure 4: Air Flow vs Pressure Pareto Plot of Estimates

Primary parameter drivers were compared to current commercial components to further revise the model and establish realistic design specifications. Identifying appropriate existing components was an integral step because the ultimate purpose of this study was to develop a realistic system that could be built and used for a microgrid at NPS. To test which specific combination of flowrate and pressure would result in the greatest liquid air output, a case study was developed that used existing specifications and determined the liquid production rate for each (Figure 5).

The system efficiency (Figure 6) varied between 5.9-6.5%, depending on the pressure ratio of the cryogenic system; higher pressure ratios correspond to greater efficiencies. While the flow rate impacts the liquid yield, flow rate has no effect on the system efficiency; the pressure ratio is the key factor for system efficiency.

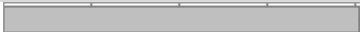
This is a significant difference from the efficiency claims of the Highview plant of 60%, likely because smaller units without large scale infrastructure and collocated regenerative capabilities would run much less efficiently. This model estimated that on average, 11.32 liters of liquid air were required to produce 1 kWh of electricity. This production rate estimation could be used as a multiplier in determining the correct tank size and expansion system design. To fulfill the constraint of 5 kWh, approximately 57 liters of liquid storage capacity would be required.

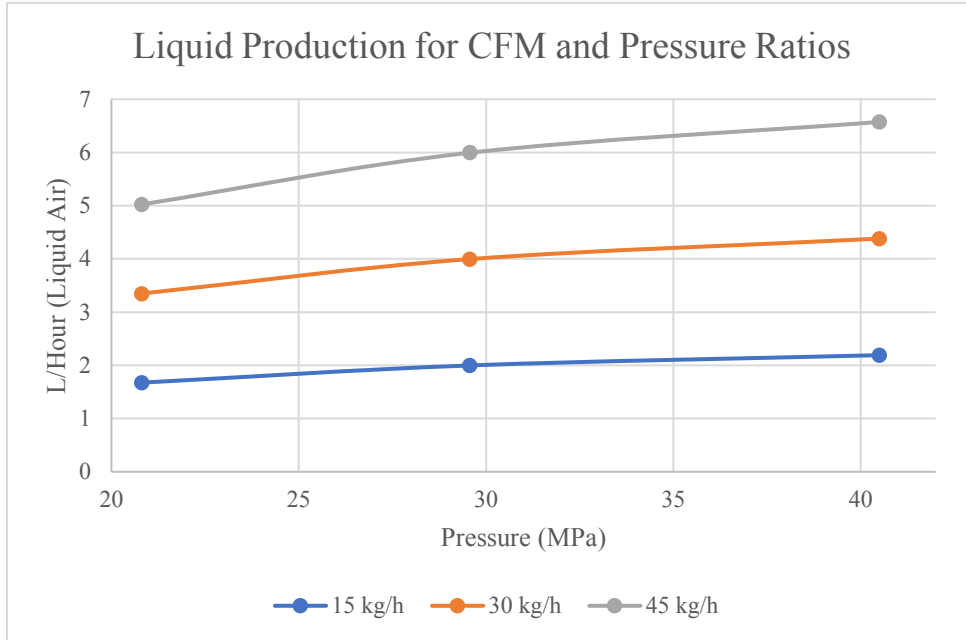

Figure 5: Liquid Production for varying CFM and Pressures

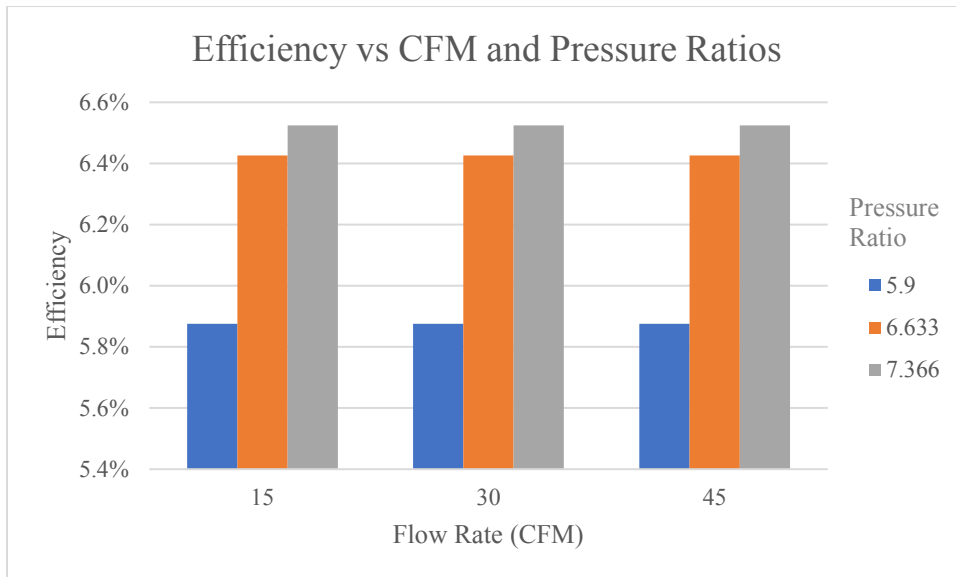

Figure 6: Efficiencies vs. CFM and Pressure Ratios

Components such as the heat exchangers, pumps, and filtration systems would need to be used in low temperature and cryogenic applications. Though a significant study on what specifications for what lower level systems was not conducted, the basic parameters were delineated in the modeling process. Table 2 summarizes this analysis and matches requirements to their source.

Table 2: Model derived component specification showing the source of each requirement

Component	Requirement	Source
Compressor	≥ 3000 PSI output pressure	Present work (Analysis)
	Maximize Flow Rate (≥ 10 CFM)	Model analysis
	Cryogenic (oil-free) rated	Safety constraint
	<18 kW input power requirement	Input power constraint
Compression Side Heat Exchanger	220K temperature differential	Present work (Analysis)
	Cryogenic operation	Operation constraint
	Power requirement combined <18 kW (with compressor)	Design basis constraint
Dewar	≥ 57 -liter capacity	Present work (Analysis)
	Ambient pressure rated	Model output
	Cryogenic insulation	Operation constraint
Cryogenic Pump	≥ 12 liters per hour	Model analysis
	Cryogenic (oil-free) rated	Operation constraint
	<18 kW (with heat exchanger/vaporizer)	Input power constraint
Expansion Side Heat Exchanger/Vaporizer	220K temperature differential	Model output
	Cryogenic operation	Operation constraint
	Power requirement combined <18 kW (with pump)	Input power constraint
Turbo-expander/generator	Minimum power 5kWh (1kW)	Output requirement
	Both liquid expansion and turbine capability	Operation constraint

5. Selection of Physical Components

The component selection is based on the parameter requirements in Table 2. Available commercial components were evaluated on the available data from the manufacturer and the flexibility their parameters allow.

5.1 Compressor

Specifications of four commercially available compressors compliant with the requirements in Table 2 were compared. The compressor chosen was the RIX 4V4B air compressor (RIX Industries n.d.) because of its superior air flow rate of 17 CFM (RIX Industries n.d.), acceptable pressure rating, cryogenic compatible design, and small footprint.. At 11.1 kW, this will operate below the maximum available power. Process simulations using the model with this compressor's specifications yielded a liquid air output of 0.7191 kg/h.



Figure 7: RIX 4V4B Air Compressor (adapted from RIX Industries n.d.)

5.2 Turbo-expander/generator

A 1kW turboexpander would require 0.72 l/h intake of air after heating. The E15H022A-SH 1kW semi-hermetic scroll expander from Air Squared is designed to work for a variety of gases and connects directly to a 60Hz generator (Air Squared n.d.). The maximum inlet pressure is 200 psi and will need to be regulated upon exiting the heat exchanger (Air Squared n.d.).

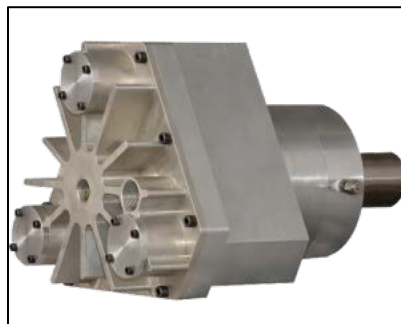

Figure 8: Air Squared 1kW Scroll Expander (adapted from Air Squared n.d.)

5.3 Dewar

A cryogenic dewar is required to store the liquid air for the specific expected power requirement. As the calculated amount of liquid to produce one kWh was 11.32 liters, five kWh would require at least 56.60 liters of tank space. As additional space would be required to ensure the tank would not overflow, a safety margin of 50% was incorporated in the design specification. The minimum tank volume was calculated to be 85 liters. The CF1636 from Cryofab is a low pressure, 117.4-liter cryogenic dewar designed for liquid gas (Cryofab n.d.). This dewar was chosen from competitors due to its larger capacity, top plate connections, and low liquid loss rate. This dewar would allow for additional storage capacity, allowing for up to 10 hours of LAES power backup.

5.4 Cryogenic Pumps

The pump is required to move liquid air out of the dewar to send it to the heat exchanger and vaporizer/turbine. The pump would be required to have a throughput of 11.985 liters/min at a pressure output of 140 psi. The Cryostar CS transfer pump is designed to move liquid gases and would be adequate for the cryogenic nature of the system (Cryostar n.d.).

5.5 Compressor Side Heat Exchanger

There are no existing off the shelf cryogenic side heat exchangers that meet our requirements, and a custom one will have to be built. In selecting an appropriate heat exchanger, it was decided to reuse the custom heat exchanger in the prototype LAES delivered to NPS from the Office of Naval Research. Reusing the component avoids a material acquisition cost, but the exchanger needs to undergo testing to ensure it meets the specifications in Table 2.

5.6 Expansion Side Heat Exchanger/Vaporizer

The vaporizer will heat the cryogenic liquid to a gas to be processed through the turbine. Heating the liquid from its 80K storage temperature to 300K can be completed using the Thermacast H3C Electric Vaporizer (Thermax n.d.). This vaporizer was chosen due to its low power consumption, cryogenic material compatibility, and heat differential. The system is designed for cryogenic materials and takes approximately 3kW to operate..

6. Summary and Future Work

This investigation modeled and simulated a proposed system to inform design and component selection. The primary parameters and factors driving the system output were identified and modeled, driving the production of a set of component specifications. Those specifications were then linked to the system requirements and model analysis. Each component was selected from commercial manufacturers using the identified specifications.

System modeling and theoretical evaluation concluded with specific component selection and testing those components in the model. However, the model is still limited in actual performance applications. The next step of this project is construction of a working prototype LAES connected to the microgrid in the NPS TPL.

Future system development will measure the actual performance of the specified design, unveil alternative design practices, validate the system requirements, and verify the model. LAES systems become more effective at a larger scale and with a greater available pool of latent energy. Application of this design can be used in waste heat from power generation on Navy installations or shipyards. Along with further investigation into renewable-source energy production, future work is required to design an effective system that is better suited to increase efficiency at naval facilities and determine methods for increasing small-scale efficiencies. This work, along with Bailey's (2019) concurrent demand-side work, maps the LAES trade space.

References

- "2016 DoD Operational Energy Strategy WEBC.Pdf." n.d. Accessed Mar 4, 2019. <https://www.acq.osd.mil/eie/Downloads/OE/2016%20DoD%20Operational%20Energy%20Strategy%20WEBC.pdf>.
- Air Squared. n.d. "E15H022A-SH 1 KW Scroll Expander." Air Squared Scroll Technology. Accessed May 12, 2019. <https://airsquared.com/products/scroll-expanders/e15h022a-sh/>.
- Amalla, Sammy, Anthony G. Pollman, and Alejandro S. Hernandez. n.d. "Construct a Small Scale Liquid Air Energy Storage (LAES) System Using MBSE and Prototyping." Thesis, Naval Postgraduate School.
- Bailey, Nicholas, Anthony G. Pollman, and Eugene Paulo. 2019. "Modeling and Simulation Approach to Support Component Selection for Demand-Based Building-Scale LAES System." Draft, Monterey, CA: Naval Postgraduate School.
- Chief of Naval Operations. 2009. "Energy." U.S. Navy: Energy, Environment and Climate Change. 2009. <http://navysustainability.dodlive.mil/energy/#Shore>.
- Cryofab. n.d. "Cryofab CF Series Dewar Flasks." Accessed May 12, 2019. https://www.cryofab.com/products/spec_sheets/Cryofab_CF_Dewar_Flask_Specs.pdf.
- Cryostar. n.d. "Cryostar Transfer Pump CS." Accessed May 12, 2019. <https://cryostar.com/datasheet/datasheet/CS.pdf>.
- "Dewar Flasks." n.d. Accessed May 12, 2019. <https://www.cryofab.com/products/Cryogenic-Dewar-Flasks>.
- Giramonti, Albert J., Robert D. Lessard, William A. Blecher, and Edward B. Smith. 1978. "Conceptual Design of Compressed Air Energy Storage Electric Power Systems." *Applied Energy* 4 (4): 231–49. [https://doi.org/10.1016/0306-2619\(78\)90023-5](https://doi.org/10.1016/0306-2619(78)90023-5).
- Highview, Alicia. n.d. "LIQUID AIR ENERGY STORAGE (LAES)," 28.
- Highview Power Storage. 2017. "Liquid Air Energy Storage." <https://www.highviewpower.com/wp-content/uploads/2018/04/Highview-Brochure-November-2017-Online-A4-web.pdf>.
- Howe, Todd. 2018. "Thermodynamic System Analysis of a Liquid Air Energy Storage System." Monterey, CA: Naval Postgraduate School. Calhoun. <http://hdl.handle.net/10945/59687>.
- Howe, Todd A., Anthony G. Pollman, and Anthony J. Gannon. 2018. "Operating Range for a Combined, Building-Scale Liquid Air Energy Storage and Expansion System: Energy and Exergy Analysis." *Entropy* 20 (10): 770.
- Kitanovski, Andrej, Alojz Poredoš, Adriano Sciacovelli, Daniel Smith, Helena Navarro, Yongliang Li, and Yulong Ding. 2016. "Liquid Air Energy Storage – Operation and Performance of the First Pilot Plant in the World."

- Lim, Sanieel, Andre Mazzoleni, Joong-Kyoo Park, Paul Ro, and Brendan Quinlan. 2013. "Conceptual Design of Ocean Compressed Air Energy Storage System." Edited by Sanieel Lim. *Marine Technology Society Journal* 47 (2): 70–81. <https://doi.org/10.4031/MTSJ.47.2.5>.
- National Renewable Energy Laboratory. 2010. "California - Annual Average Wind Speed at 80 m." <https://windexchange.energy.gov/maps-data/325>.
- Pollman, Anthony G. 2013. "Energy Optimization: A Combat Multiplier." *Marine Corps Gazerre Ideas & Issues (Logistics)* (Nov 2013): 69–73.
- Riley, Richard. 2015. "Second Trilateral Energy Storage Workshop." Presentation presented at the Second Trilateral Energy Storage Workshop, British Embassy, Paris, Nov 19. <https://www.slideshare.net/UKinFrance/energy-storage-9-richard-riley-highview>.
- RIX Industries. n.d. "4V4B Series." Accessed May 12, 2019. <https://www.rixindustries.com/4v4b>.
- Roberts, Billy J. 2018. "Direct Normal Solar Irradiance." National Renewable Energy Laboratory. https://www.nrel.gov/gis/images/solar/solar_ghi_2018_usa_scale_01.jpg.
- Salvini, Coriolano, Pietro Mariotti, and Ambra Giovannelli. 2017. "Compression and Air Storage Systems for Small Size CAES Plants: Design and Off-Design Analysis." *Energy Procedia* 107: 369–76. <https://doi.org/10.1016/j.egypro.2016.12.178>.
- Thermax. n.d. "Thermacast Electric Vaporizer." Data Sheet. Accessed May 12, 2019. <http://files.chartindustries.com/PDS1.0.pdf>.
- United States Navy. 2010. "Naval Energy Strategic Roadmap." Oct 2010. https://www.secnav.navy.mil/eie/ASN%20EIE%20Policy/Naval_Energy_Strategic_Roadmap.pdf.
- . 2019. "Navy Shore Energy Program." Navy Shore Energy Program. 2019. https://www.cnic.navy.mil/om/base_support/facility_system_investment/Navy_Shore_Energy_Program.html.
- Willis, Ryan. 2018. "Modeling of a Building-Scale Liquid Air Energy Storage System with ASPEN HYSYS." Monterey, CA: Naval Postgraduate School.