



Calhoun: The NPS Institutional Archive
DSpace Repository

NPS Scholarship

Theses

1993-09

Evaluation of wireless local area networks

McBee, Charles L.

Monterey, California. Naval Postgraduate School

<https://hdl.handle.net/10945/39977>

This publication is a work of the U.S. Government as defined in Title 17, United States Code, Section 101. Copyright protection is not available for this work in the United States.

Downloaded from NPS Archive: Calhoun



Calhoun is the Naval Postgraduate School's public access digital repository for research materials and institutional publications created by the NPS community. Calhoun is named for Professor of Mathematics Guy K. Calhoun, NPS's first appointed -- and published -- scholarly author.

Dudley Knox Library / Naval Postgraduate School
411 Dyer Road / 1 University Circle
Monterey, California USA 93943

<http://www.nps.edu/library>

AD-A275 133



2

NAVAL POSTGRADUATE SCHOOL Monterey, California



SDTIC
ELECTE
JAN 3 1 1994
S E D

THESIS

EVALUATION OF
WIRELESS
LOCAL AREA NETWORKS

by

Charles L. McBee

September, 1993

Thesis Advisor:

Prof. Myung W. Suh

Approved for public release; distribution is unlimited.

94 1 28 001

94-02864



REPORT DOCUMENTATION PAGE

Form Approved
OMB No. 0704-0188

Public reporting burden for this collection of information is estimated to average 1 hour per response, including the time for reviewing instructions, searching existing data sources, gathering and maintaining the data needed, and completing and reviewing the collection of information. Send comments regarding this burden estimate or any other aspect of this collection of information, including suggestions for reducing this burden, to Washington Headquarters Services, Directorate for Information Operations and Reports, 1215 Jefferson Davis Highway, Suite 1204, Arlington, VA 22202-4302 and to the Office of Management and Budget, Paperwork Reduction Project (0704-0188), Washington, DC 20503

1. AGENCY USE ONLY (Leave blank)	2. REPORT DATE September 1993	3. REPORT TYPE AND DATES COVERED	
4. TITLE AND SUBTITLE EVALUATION OF WIRELESS LOCAL AREA NETWORKS		5. FUNDING NUMBERS	
6. AUTHOR(S) McBee, Charles L., LT, MSC, USN		8. PERFORMING ORGANIZATION REPORT NUMBER	
7. PERFORMING ORGANIZATION NAME(S) AND ADDRESS(ES) Naval Postgraduate School Monterey, CA 93943-5000		10. SPONSORING / MONITORING AGENCY REPORT NUMBER	
9. SPONSORING / MONITORING AGENCY NAME(S) AND ADDRESS(ES) Naval Postgraduate School Monterey, CA 93943-5000		11. SUPPLEMENTARY NOTES The views expressed in this thesis are those of the author and do not reflect the official policy or position of the Department of Defense or the U.S. Government.	
12a. DISTRIBUTION / AVAILABILITY STATEMENT		12b. DISTRIBUTION CODE	
13. ABSTRACT (Maximum 200 words) <p>This thesis is an in-depth evaluation of the current wireless Local Area Network (LAN) technologies. Wireless LANs consist of three technologies; they are infrared light, microwave, and spread spectrum. When the first wireless LANs were introduced, they were unfavorably labeled slow, expensive, and unreliable. The wireless LANs of today are competitively priced, more secure, easier to install, and provide equal to or greater than the data throughput of unshielded twisted pair cable. Wireless LANs are best suited for organizations that move office staff frequently, buildings that have historical significance, or buildings that have asbestos. Additionally, an organizations may realize a cost savings of between \$300 to \$1,200 each time a node is moved.</p> <p>Current wireless LAN technologies have a positive effect on LAN standards being developed by the Defense Information System Agency (DISA). DoD as a whole is beginning to focus on wireless LANs and mobile communications. If system managers want to remain successful, they need to stay abreast of this technology.</p>			
14. SUBJECT TERMS Local Area Networks, Wireless Local Area Networks, Mobile Communications		15. NUMBER OF PAGES 138	16. PRICE CODE
17. SECURITY CLASSIFICATION OF REPORT Unclassified	18. SECURITY CLASSIFICATION OF THIS PAGE Unclassified	19. SECURITY CLASSIFICATION OF ABSTRACT Unclassified	20. LIMITATION OF ABSTRACT UL

Approved for Public release; distributions is unlimited.

Evaluation of Wireless
Local Area Networks

by

Charles L. McBee
Lieutenant, Medical Service Corps., United States Navy
B.B.A/M.I.S., Texas Tech University, Lubbock

Submitted in partial fulfillment
of the requirements for the degree of

MASTER OF SCIENCE IN INFORMATION TECHNOLOGY MANAGEMENT

from the

NAVAL POSTGRADUATE SCHOOL

September, 1993

Author:



Charles L. McBee

Approved by:



Prof. Myung W. Suh, Thesis Advisor

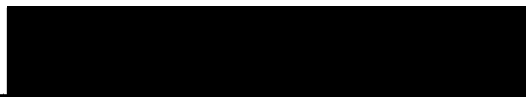

Prof. Tung X. Bui, Second Reader



Prof. David R. Whipple, Chairman
Department of Administrative Sciences

ABSTRACT

This thesis is an in-depth evaluation of the current wireless Local Area Network (LAN) technologies. Wireless LANs consist of three technologies; they are infrared light, microwave, and spread spectrum. When the first wireless LANs were introduced, they were unfavorably labeled slow, expensive, and unreliable. The wireless LANs of today are competitively priced, more secure, easier to install, and provide equal to or greater than the data throughput of unshielded twisted pair cable. Wireless LANs are best suited for organizations that move office staff frequently, buildings that have historical significance, or buildings that have asbestos. Additionally, an organizations may realize a cost savings of between \$300 to \$1,200 each time a node is moved.

Current wireless LAN technologies have a positive effect on LAN standards being developed by the Defense Information System Agency (DISA). DoD as a whole is beginning to focus on wireless LANs and mobile communications. If system managers want to remain successful, they need to stay abreast of this technology.

Accession For	
NTIS CRA&I	<input checked="" type="checkbox"/>
DTIC TAB	<input type="checkbox"/>
Unannounced	<input type="checkbox"/>
Justification	
By	
Distribution /	
Availability Codes	
Dist	Avail and / or Special
A-1	

TABLE OF CONTENTS

I. INTRODUCTION	1
II. BACKGROUND OF LOCAL AREA NETWORKS	3
A. THE EVOLUTION	3
B. WHAT IS A LAN?	7
C. WHAT IS A WIRELESS LAN?	8
D. REASONS TO GO WIRELESS	8
E. EXPECTED BENEFITS OF WIRELESS LANs	10
III. TECHNOLOGIES FOR WIRELESS LANs	12
A. LAN TECHNOLOGIES	12
1. CSMA/CD	13
2. TOKEN PASSING	15
B. WIRELESS LAN TECHNOLOGIES	15
1. INFRARED LIGHT LANs	16
a. Overview	16

b.	Infrared Product Evaluation	21
2.	VHF/UHF NARROW-BAND RADIO-BASED LANs	23
a.	Overview	23
b.	Advantages and Disadvantages of Narrow Band Radio ..	28
c.	Product Evaluation for HF Wireless Networks	29
3.	SPREAD SPECTRUM RADIO-BASED LANs	36
a.	Spread Spectrum Overview	36
(1)	Frequency Hopping	38
(2)	Direct Sequence Coding	40
b.	Product Evaluation for Spread Spectrum	43
(1)	NCR WaveLAN	43
(2)	Windata's FreePort	47
C.	STANDARDS FOR WIRELESS LAN	50
D.	HEALTH ISSUES	52
IV.	DESIGN CONSIDERATION FOR WIRELESS LANS: CASE STUDY ..	55
A.	THE DESIGN	55
B.	THE SCENARIO	55
C.	ADVANTAGES OF WIRELESS LANS FOR THE HOSPITAL ..	57

D.	DISADVANTAGES OF WIRELESS LANS FOR THE HOSPITAL	58
E.	COMPARING WIRELESS LAN TECHNOLOGY FOR THE HOSPITAL	59
F.	SPREAD SPECTRUM TECHNOLOGY	60
G.	RF PROPAGATION PROBLEMS	61
H.	CONCLUSIONS	64
V.	CONCLUSION AND RECOMMENDATIONS	66
A.	CONCLUSION	66
1.	THE WLAN SELECTION	68
B.	OTHER MOBILE COMMUNICATION	69
1.	OVERVIEW	69
2.	INTERNATIONAL MOBILE COMMUNICATIONS	69
3.	WIRELESS PBX	70
C.	RECOMMENDATIONS	71
	APPENDIX A	72

APPENDIX B 84

APPENDIX C 117

LIST OF REFERENCES 124

INITIAL DISTRIBUTION LIST 128

I. INTRODUCTION

This thesis is designed to introduce and to present the current status of Wireless Local Area Network technology to information system managers within the Department of Defense. For many years, Local Area Networks (LANs) have used cables to connect Personal Computers (PCs) to a network. Wireless Local Area Networks (WLANs) eliminate the need for and the cost of cable installation each time a PC is moved within an office or organization. When WLANs were first introduced, they were labeled expensive, slow, and non-secure. Because of those early impressions system managers would not seriously consider WLAN technology. It is time for the system manager to re-evaluate the WLAN technology and become aware of the cost savings and potential benefits of the technology.

There are numerous examples of technological advances that are the result of the interest and funding by governmental agencies. The United States government is the key player in the development and use of computers as we know them today. For example, when the computer was first introduced, it was the government that saw the potential benefits of the computer and was the first to purchase a computer. To expound on the issue a little bit further, Andrew Metcalf said:

If technology is marketable or useable in any way, it will be adopted by commercial business and government offices. This is a demonstrable fact, one

that gets proven again and again with virtually every new invention or technology achievement. In the field of information management, we have seen organizations almost immediately make use of innovations that make it easier, faster or more convenient for them to write, calculate, edit, communicate, or store the myriad of elements of information they need to process. At different times in history, thousands of new inventions have been adopted by government and business, including the abacus, printing press, typewriter, adding machine, telegraph, radio, telephone, camera, audio recorder, Ditto[®] machine, photocopier, television, telefax, calculator, and of course computer.[Ref. 1]

There are advances in the WLAN technology that are providing more options for LAN topologies and at the same time reducing the cost of installing a LAN. The performance of the WLANs has been steadily improving and, at the same time, the price has been declining.

This thesis will enlighten the reader as to the advantages and disadvantages of the three WLAN technologies, the applicable topologies, the various performance factors, and the cost analysis. The case study at the end of the thesis should provide an adequate level of explanation for introducing WLANs to Commanding Officers.

II. BACKGROUND OF LOCAL AREA NETWORKS

A. THE EVOLUTION

The local area network (LAN) evolution began with the introduction of the first microcomputer in the early 1980s. It took almost thirty years to develop and to refine the concept and the technology of a LAN as we know it today.[Ref. 2]

The computers in the 1950s were called *mainframes* and were not designed to interact or respond to the user in an on-line capacity. The technology for users to interact with the computers of that time was to use coded punch cards. These cards would be read by a peripheral device commonly called a *card reader*. These devices were operated by a computer operator (not the user) and the card reader would read these cards (80 columns of code or data per card represented one line of code) at approximately 300 cards per minute. These machines would often misread a card or mutilate a card to the point that it could not be used again. However, once the cards were successfully fed or loaded into the computer, the computer would begin processing that job. The printed output and/or punched card output would be available the following work day. This process was known as the *batch* approach.[Ref. 2]

In the 1960s, computer use was still limited to the large corporations that could afford them. The LAN evolution began to take root at this time by allowing smaller corporations to connect (via telephone line) to a card reader, printer, and a terminal from their location or from a remote site away from the mainframe. This arrangement allowed shared computer access via a leased telephone line to the large corporation's mainframe computer. This was called *time-sharing*. It allowed the smaller corporations access to a computer and its resources without having to sacrifice a large capital expenditure.[Ref. 2]

By the 1970s, the development of the minicomputer triggered the largest evolution jump for LANs. Although the time sharing concept was sound, the inherent problem of sending and receiving data over telephone lines to the mainframe was lack of speed. The minicomputer offered basically the same features as the large mainframes, but it was much faster and its size was drastically reduced. The cost of a minicomputer was also lower than a mainframe, and thus it became possible for companies to own their own computer. The cost of a minicomputer was in the range of several hundred thousands of dollars while the mainframe costs were several million dollars. The minicomputer system was typically a turn-key system, and all that was needed to make it operational was a computer terminal and the cable to the computer. The cost of the minicomputer made it possible for a minicomputer to be located in several departments.

The concept of several departments having their own computer rather than using one central or corporate computer was known as *distributed processing*. The evolution continued through this period by focusing on the need for the minicomputers to communicate with one another. As a result, programmers began writing their own communication code or software that would allow communication between the different computer departments.[Ref. 2]

The early 1980s saw the introduction of the microcomputer (PC). At that time corporations started re-evaluating their minicomputers. These work horses of the seventies were not able to keep up with the computing speed of the PC and could not run the business software that was beginning to appear on the market by the major PC vendors.[Ref. 2]

Throughout the 1980s, the price/performance ratio for PCs has improved at an accelerating rate, thus fueling the so called personal computer revolution. This personal computer (PC) revolution has led to more intelligent desk top devices with graphical user interface and personal productivity tools. The organizational effect of this movement was to empower the employees and allow them to become more productive. This venture on the organizations' part provided all types of software and hardware to the employee. "The decremental cost of technology facilitated the distribution of personal computers." [Ref. 3] As Mil Ovan, Worldwide Marketing Manager for

Motorola, points out, the projections for the 1990s indicate that personal computers within business will continue to grow at an aggressive pace (see TABLE 1).

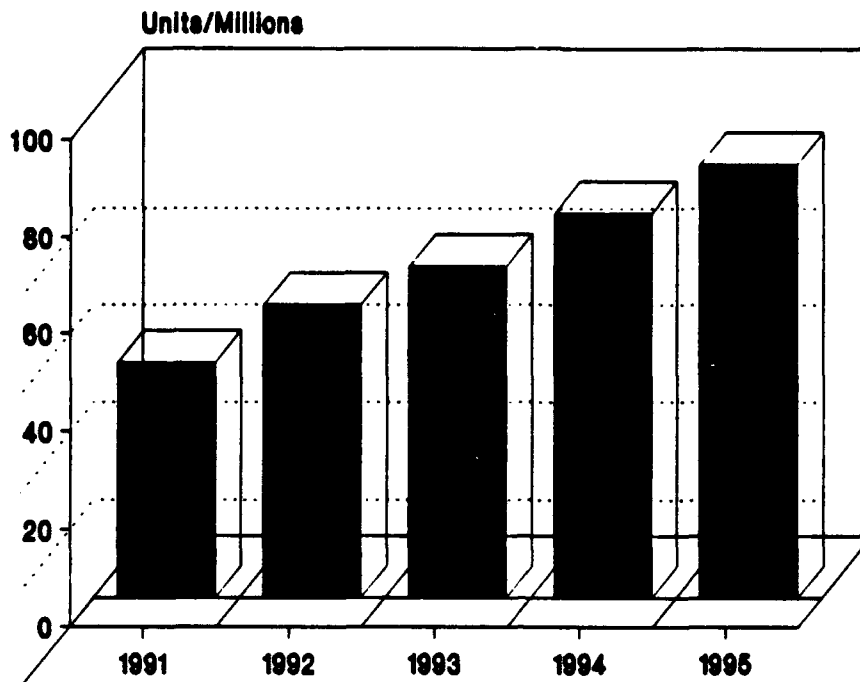

Source: IDC

TABLE 1
WORLDWIDE BUSINESS PERSONAL COMPUTER INSTALLED
BASE

Source from [Ref. 3]

The proliferation of personal computers with corporate information residing on these individual hard disks created the problem of not being able to share information with work groups or management that needed the information.[Ref. 3]

In addition to sharing hardware resources, a LAN shares its software resources, thus contributing to the cost savings of implementing a LAN. Ovan also points out that

... despite the declining cost of personal computers and associated technology, it was and still is considerably expensive to "fully load" the work force with all of the applications it needs. The ability to share applications became desirable. It was these trends which highlighted the need for Local Area Networks (LANs).[Ref. 3]

B. WHAT IS A LAN?

A definition of a LAN will vary with different authors and textbooks; however, Stan Schatt in his book provides a comprehensive description of a LAN. He states that a LAN

... is a system which allows microcomputers to share information and resources within a limited (local) area (generally less than one mile from the file server to a workstation). A LAN requires that the individual workstations (microcomputer) be physically tied together by cabling (usually coaxial or twisted pair), and that some network software reside on the workstation's hard disk (this permits the sharing of peripherals, data, and application programs).[Ref. 2]

These microcomputers and peripherals are usually connected by one or a combination of the following mediums:

- **Thick or Thin Coaxial:** "A cable consisting of one conductor, usually a small copper tube or wire, within and insulated from another conductor of larger diameter, usually copper tubing or copper braid." [Ref. 4]
- **Twisted Pair:** A cable that "consists of two insulated copper wires arranged in a regular spiral pattern." [Ref. 4] The rationale for the spiral pattern is so that each wire experiences the same noise or electromagnetic interference of the signal being transmitted. This configuration of twisting the wires reduces the noise of the signal that is being transmitted. [Ref. 2] Shielded twisted pair is cable that provides higher data-grade quality. It is a "24-gauge two-twisted-pair - one pair of wires to transmit data and one pair to receive data." [Ref. 2]

- Optical Fiber: A cable that "has a cylindrical shape and consists of three concentric sections: the core, the cladding, and the jacket." The optical fiber is a thin (2 to 125 μm), flexible medium capable of conducting an optical ray." [Ref. 4]

C. WHAT IS A WIRELESS LAN?

A wireless LAN is a LAN that uses a wireless medium to connect Personal Computers (PCs) in a LAN. It is in addition to the four previously mentioned media.

Wireless LANs are not comprised of a single technology. As of the time of this thesis, there are currently three technologies available for a wireless LAN.

One form of wireless technology uses *narrow band* radio-frequency (RF) transmission in the VHF/UHF spectrum range. Narrow band radio transmission is similar to that used by a local AM/FM radio station, in that the radio station is given a certain frequency and *narrow* bandwidth to operate within. The second type uses spread spectrum (SS) RF transmission. This technology will be discussed in depth later in this thesis. The third type uses a lightbase transmission (infrared). [Ref. 5]

D. REASONS TO GO WIRELESS

There are many reasons, some obvious and some other obscure, as to why an organization would want to utilize wireless. The main reasons for this thesis, however, are concentrated around the cost drawbacks of installing and maintaining a cable network. The cost of the cable remains relatively inexpensive, but the labor cost of

installing cable can become very costly. Depending upon the geographical locations of a company, the cost to wire a node in a typical building ranges from \$300 to \$1,200. This does not take into account the disruption and non-productive time within the office while the cable is being installed.[Ref. 6] In addition to the indirect cost previously mentioned, there is a cost of down time or waiting time for the cable to be installed. Jim Scott, systems analyst at Boeing Computer Services in Bellevue, Washington, argues that the average wait for cable to be pulled takes anywhere from 60 to 90 days^a. [Ref. 7]

A wired network does not have the ease of mobility to relocate to different locations as does a wireless network. After a network is installed, it is not uncommon for users to begin moving or relocating within the organization. As a result of these moves, computer departments are burdened with additional network costs.

Moreover, a Peat Marwick study found that 30 to 50 percent of the users on a typical LAN relocate annually. In fact, says Bill Johnson, a senior partner in Chicago, it's not uncommon for an entire LAN-connected work group to move once or even twice a year." [Ref. 7]

Johnson concluded that the Peat Marwick study found that the *direct cost* to move a node averages \$300. [Ref. 7]

^a Scott is responsible for over 45,000 wired Ethernet nodes and has also said "Boeing spends millions each year on wiring and encounters many problems with wire, including security and electrical interference." [Ref. 7]

The user or the network manager should not be so naive as to think that because a cable does not have any moving parts that it will not cause problems to the network now or in the future. It is estimated that "approximately 80 percent of all network faults are cable related." [Ref. 8] The following is an explanation as to the causes of cable problems:

- Cable is yanked through ceilings and pulled too tightly around corners; stepped on by users and technicians; and repeatedly spliced, crimped, and connectorized. The maximum distances are violated, and after much handling and manipulation, the connectors loosen and the wireless fibers become misaligned or damaged. Eventually, the data just does not pass through the line anymore. [Ref. 8]

E. EXPECTED BENEFITS OF WIRELESS LANs

By using a wireless LAN the typical problems associated with physically wiring a network will be eliminated. A wireless network provides connectivity without wires, can feasibly be installed in difficult areas, decreases design cost, decrease installation labor cost, and provides long-term cost savings. [Ref. 9]

A wireless LAN removes the problems and the costs of nodes being relocated or organizations reorganizing. It solves the problem of wiring in asbestos areas or in historical buildings. Wireless networks are also very beneficial for temporary project sites because of the ease to relocate wireless. Two examples of a temporary site are the setup of a Naval Fleet Hospital or a Mobile Army Medical Hospital (MASH). Another example would be the setup of a temporary computer facility while the permanent

facility is either being repaired or constructed. LCDR Mike Greenauer, the Directorate for Project Management at the Naval Medical Information Management Center, Bethesda, Maryland, commented that the possible applications of the wireless technology includes

. . . use in facilities where asbestos in walls/ceilings makes running conduit expensive, in facilities where construction does not allow for conduit runs (i.e., some of our 'typhoon-proof' overseas sites with VERY thick walls), and in sites where there is either temporary relocation of staff (such as when they go into trailers during construction modifications) or frequent movement of staff.[Ref. 10]

As previously mentioned, to wire a *typical* building will run anywhere from \$300 to \$1,200 per node. Some buildings are not typical and are resistant to wiring or cabling. An organization

. . . may want to avoid (or may be prohibited from) disturbing the walls of a historic building. If a building contains asbestos, you will have to go through prescribed (and expensive) asbestos abatement procedures before walls and ceilings can be opened and cable pulled.[Ref. 6]

The long term cost savings of a wireless LAN could be realized within the first one or two years of operations. Depending upon the local economy, every time a node is moved in a wireless environment, the organization can expect an approximate cost savings of \$300. As previously noted, 30 to 50 percent of the nodes within an organization are relocated annually. Therefore, substantial savings can be realized.

III. TECHNOLOGIES FOR WIRELESS LANS

A. LAN TECHNOLOGIES

Analyzing and determining an organization's needs will provide valuable information as to which wireless technology is best suited to that organization. Before an organization installs its first local area network (LAN), it will more than likely develop a Request For Proposal (RFP) or complete its own needs analysis. The RFP or the needs analysis forces an organization to analyze or examine itself so that the right LAN is chosen to fulfill the needs of the organization. The RFP forces an organization to look at long- and short-term strategic goals^b. After completing and evaluating the RFP and determining the number of potential users and the response time they require for their LAN, the decision to use a certain LAN topology (Token Ring or CSMA/CD Bus) may be obvious. For example, Figure 1 shows that an organization with a small number of users potentially has a better system response time using CSMA/CD bus; and organizations with a large number of users will have a faster system response time if they use token-ring.[Ref. 11]

^b The questions of a RFP may be similar to that in Appendix A.

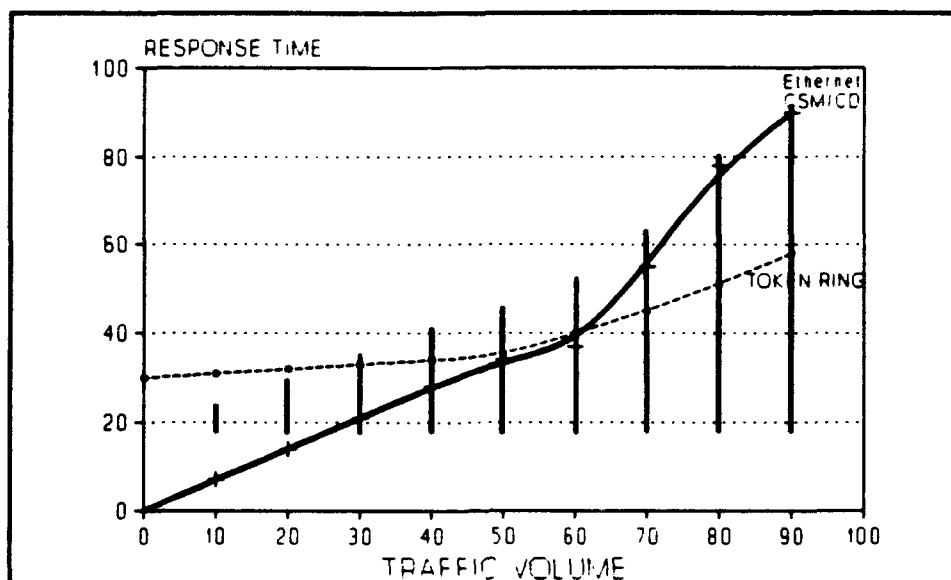

Figure 1
 COMPARISON OF CSMA/CD AND TOKEN RING
 Source from [Ref. 11]

1. CSMA/CD

Without going into too much depth on the two technologies of CSMA/CD Bus (which consists of broadband and baseband), the easiest way to imagine this LAN technology is to imagine a telephone system with a party-line capability. That is, if two individuals are talking to one another, someone else could call in and join the conversation already in progress. Politeness still plays a part in this system, because before someone begins to speak, he listens to ensure that no one else is talking before he says something (listen before talk). If there are only a few individuals on the line, no severe problems exist. However, if the line becomes congested with additional individuals wanting to talk on the same telephone line, a very strong probability exists

that two or more individuals may begin to talk at the same time. If they start talking and hear someone else beginning to talk, they stop talking, excuse themselves, and wait a random length of time before beginning to talk again when the line is quiet. The process begins again by waiting for a break in the conversation before trying to speak. In the most elementary form, this is called Carrier-Sense Multiple Access/Collision Detection (CSMA/CD). In this LAN environment, everyone has the same chance to speak.

Ethernet, a registered trademark of Xerox, was the first LAN product that implemented CSMA/CD. Ethernet specification of CSMA/CD became the basis for the IEEE 802.3 standards. For this reason, the two names (Ethernet and 802.3) are often used synonymously, even though the technical frame format (transmission frame) of Ethernet and the standards set by IEEE 802.3 varies.[Ref. 12]

Ethernet's standard for transmission or signaling rate is established at 10 Mbps. This number may sound like a large number, but upon closer analysis of the actual data throughput, this number can decrease to as low as 1 Mbps, but not more than 8 Mbps, and with an average throughput between 3 and 4 Mbps. These low throughput numbers are a result of internal inefficiencies and other overhead factors relating to the Ethernet environment.[Ref. 12]

2. TOKEN PASSING

With the Token-Ring topology or approach, "... there would be a token which serves as a symbol of authority, enabling a particular person to speak." [Ref. 2] Once the person holding the token finished speaking, the token would be released and it would travel or follow a predetermined circular path of users until it found a user that requested to speak on the network. This type of system is termed "a deterministic media-access control system" because the actual waiting time a user will experience is known.

Token-Ring mechanism has been adopted as the IEEE 802.5 standard. IEEE 802.5 has three data transmission speeds; 1, 4, and 16 Mbps.

B. WIRELESS LAN TECHNOLOGIES

Today's wireless LAN technology is centered around infrared light, microwave, and spread spectrum. Each wireless technology, for the most part, is confined to using only one LAN topology. For example, a vendor manufacturing infrared light wireless LANs supports only Token Ring topology. Another vendor that employs microwave technologies requires that its product only be used for Ethernet LANs.

1. INFRARED LIGHT LANs

a. Overview

Light waves provide a higher and wider frequency range than radio. According to Jim Carr, "the primary advantage of infrared technology is its wide bandwidth, allowing it to carry hundreds of megabits of data per second." [Ref. 13] The visible light frequency spectrum ranges from red (low) to violet (high). Even though the word "low" for the red frequency has a particular perception, these light-wave frequencies are still much higher than radio. [Ref. 6] The light wave frequency that is below red is invisible to the human eye. This invisible light is called *infrared*. Even though you can not see infrared, it can be felt. For example:

The heat from the sun reaches the Earth via infrared radiation. When we stand in front of a fire, and feel warmth on the side of our bodies facing the fire -- but not on the other -- we're feeling infrared radiation. [Ref. 6]

There are two forms or technologies for infrared wireless LANs. *Passive* infrared does not require the nodes to be in direct line of sight with each other for transmission and communication. *Active* infrared, however, does require that the nodes be in line of sight of each other.

As illustrated in Figure 2, the passive infrared LAN makes use of the reflected light waves off of common walls and/or ceilings to network nodes. [Ref. 14]

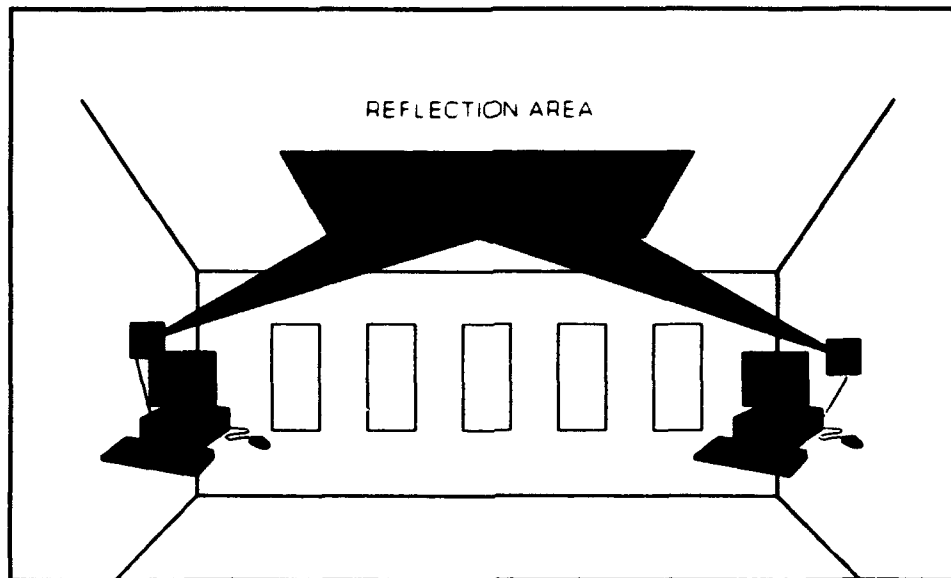

Figure 2
PASSIVE INFRARED
Source from [Ref. 14]

Each network node has a transmit/receive unit that sends or views and collect pulses of light. These pulses are then converted to electrical signals.[Ref. 14]

This technique would be an ideal solution of networking an entire office or room except for one problem - the range is limited to a radius of about 30 feet.[Ref. 6] An example of passive infrared would be the common television remote channel selector. Depending upon the type of remote control you may have, you should be able to point the remote control in an angle off the ceiling at the television and enter commands, and the television should receive them.

In contrast to passive infrared, active infrared must be in direct line of sight of the nodes[Ref. 15]. Figure 3 depicts a typical active infrared LAN topology.

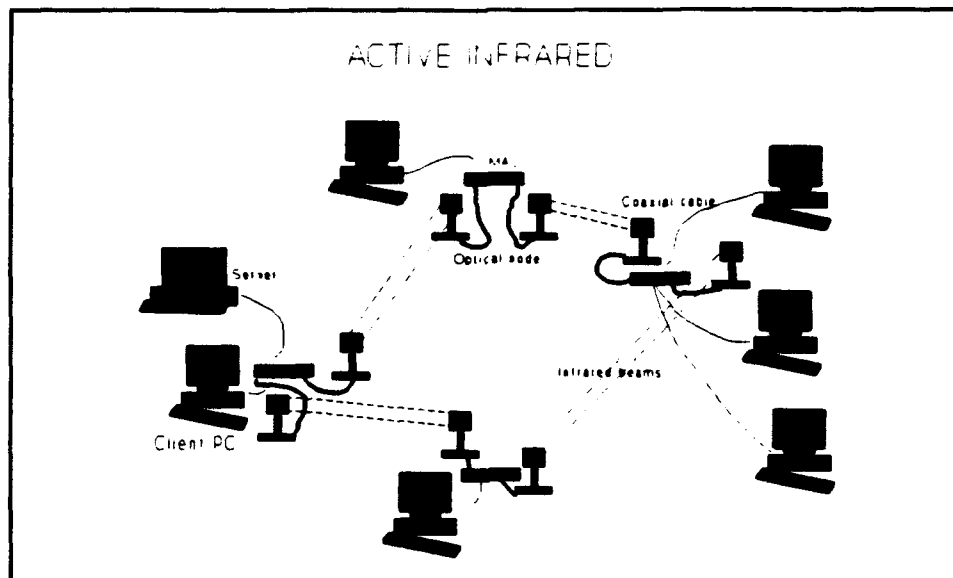

Figure 3
ACTIVE INFRARED
 Source from [Ref. 15]

To understand further the differences between passive and active infrared, one should examine a flashlight that has the capability of varying the radius of the light beam. The power of the light bulb from the flashlight adjusted to visualize a large area produces the same power as it does when the beam is concentrated in a smaller radius. The brightness or the overall candlepower between the two are different. The difference is very easy to visualize. When the light is set for wide, the brightness is diffused, and as the distance increases, the light reaching the area will not be very bright. When the narrow or a smaller radius light beam is used, the area illuminated is much brighter and can be seen from a greater distance.

As aforementioned, passive infrared is confined to a smaller area and the area must use high ceilings in order to diffuse or flood the entire room with infrared light. Its range is limited to a distances of about 23 feet (7 Meters).[Ref. 16] Active infrared, on the other hand, uses a much more narrow beam to communicate to the nodes and as such allows for greater distance between nodes (70 to 80 feet). A common problem between the two approaches is the interference and disruption of service caused by something or someone blocking the optical nodes. This problem does not seem to be as big a problem for a passive network because the room is typically flooded with infrared light, and the receiving nodes are able to pick up the signal from multiple directions or paths. However, the more diffused a signal becomes, the lower the data rates, and the distance that the signal can be sent reliably is reduced.[Ref. 13] Another shared problem of infrared networks "... is their susceptibility to interference from other light sources." [Ref. 13] Active networks with a more focused light beam have a greater resistance to light interference than passive networks.

Unlike radio frequencies, infrared light cannot pass through walls. Some advantages of using infrared are "light frequencies are not controlled by any government agency, and no license is required." [Ref. 6] In addition to being the technology of choice for the remote control industry (videocassette recorders, television, etc.), "infrared is totally immune to radio or electrical interference." [Ref. 6] The

disadvantages of infrared proves to also be a benefit for network security. As previously mentioned, infrared transmission is limited by distance and can not penetrate walls. Peter Clegg addressed the security issues of active infrared LANs:

Security for the infrared products does not include anything like scrambling or encryption. The fact that infrared requires direct line of sight is the major deterrent to intruders. In order for someone to tap into the InfraLAN network, they would have to install another base unit and adjust all the sensors to point to each other. That should be a fairly obvious security breach.[Ref. 17]

Clegg contrasted the security issues of passive to active infrared and said that passive infrared "bounces the infrared signal off of the common wall or ceiling which could allow a partially concealed sensor to pick up the signal without being clearly visible." [Ref. 14]

The actual cost of using an infrared LAN system will vary, but at the time of this thesis, the list price for the InfraLAN hardware which supports six workstations on a multistation access unit (MAU) is \$465 and \$630 (per node) for the 4 Mbps and 4/16 Mbps respectively. Using information from InfraLAN Technologies Inc. on their product InfraLAN, and a best and worst case LAN cabling cost of \$300 and \$1,300 per node, respectively. A comparison amortized cost between a cabled network and a infrared system is provided in Figure 4.

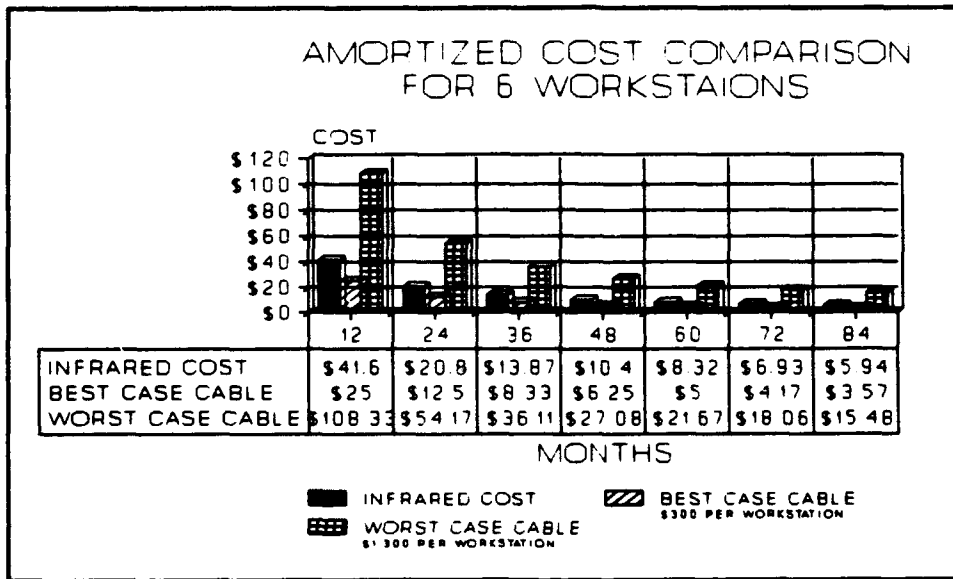

Figure 4
INFRARED COST COMPARISON
Source from [Ref. 16]

As shown in Figure 4, the monthly cost per node for one year is \$41.6 for InfraLAN. If the cost was extended through the fifth year, \$8.32 would be the average monthly cost per node. This cost does not include the token ring network interface card (NIC).

b. Infrared Product Evaluation

InfraLAN Technologies Inc. is one of two companies that are producing a high speed infrared LAN at this time. InfraLAN until September 1992 was owned and marketed by BICC Communications. The other company is call A.T. Schindler

Communications Inc., and its two products are called FIRLAN TR (for token ring networks) and FIRLAN ET (for Ethernet networks).

InfraLAN, like all wireless LANs, provides limited flexibility to its user. The product can only be used on a Token Ring network and cannot penetrate walls or opaque objects. It must operate in a line-of-sight network configuration. The maximum distance between nodes is 80 feet.

Its advantages include a maximum throughput of 16 Mbit/s.[Ref. 18] "It is easy to install and easy to disassemble and relocate where necessary." [Ref. 19] InfraLAN is also resilient to a changing office environment.

In the event of the primary infrared path between two optical nodes being obstructed, the signal will automatically re-route on a backup path around the network to reach the desired location. This ensures that signal integrity is maintained at each user location at all times without loss of data.[Ref. 19]

The FIRLAN TR network is believed to be similar to that of the InfraLAN network in that it is also a 16 Mbit/s system and requires line of sight to operate. The difference between the two is the cost and the operating distance. The average cost per node for the FIRLAN TR is about \$250 and the operating distance is 300 feet.[Ref. 18] (Note: A.T. Schindler Communications Inc. was reluctant to provide technical information/specifications on its two products - FIRLANET, which operates on Ethernet, and FIRLAN TR, which operates on Token Ring - to the author for

evaluation and review. Thus, only a general discussion concerning their product is done.)

In order to compare the capabilities of different infrared vendors, TABLE 2 provides information on vendor, product, components, maximum throughput/range, and average cost.

Vendor	Product	COMPONENTS	Max Throughput/ Range	Average Cost
A.T. Schindler Communications Inc. (Nepean, Ontario 613-723-1103)	FIRLAN ET	Wireless transceiver connected to cabled Ethernet segment supporting up to 29 PCs; wireless transceiver attached to one PC; wireless hub	10 Mbit/s; 300 ft. (line of sight)	\$250 per node
A.T. Schindler Communications Inc. (Nepean, Ontario 613-723-1103)	FIRLAN TR	Wireless transceiver connected to token ring multiple access unit; wireless hub	16 Mbit/s; 300 ft (line of sight)	\$250 per node
InfraLAN Technologies Inc. (Acton, Mass. 508-266-1500)	InfraLAN	Wireless Transceiver supporting up to six PCs over cable	16 Mbit/s; 80 ft (line of sight)	\$630 per node
Photonics Corp. (San Jose, Calif. 408-955-7930)	Collaborate	Combined ISA or EISA adapter and wireless transceiver; combined parallel port network adapter and wireless transceiver	1 Mbit/s 37 ft. (diffused)	\$400 per node

TABLE 2
Source from [Ref. 18]

2. VHF/UHF NARROW-BAND RADIO-BASED LANs

a. Overview

There are two basic technologies that are being used for wireless radio-based networks: ". . . conventional, or single-frequency radio, and spread spectrum." [Ref. 6] The single-frequency or "narrow band radio systems are relatively

old technology."[Ref. 20] Spread spectrum technology, on the other hand was invented for the military during World War II. This technology was used for reliable and secure battlefield communications.

In fact, spread-spectrum technology was developed . . . to prevent interference from German ships that attempted to jam the steering signals of Allied torpedoes.[Ref. 21]

Before proceeding, it would be beneficial to the reader to understand several terms. The two most basic terms are *frequency* and *Hertz*.

Frequency is perhaps the most fundamental aspect of radio. It refers to the rate at which an alternating current (or voltage, as the case may be) varies -- how often it repeats. The unit of measure is Hertz (Hz). One cycle per second would be 1 Hz.[Ref. 6]

In addition to the terminology, it is important to understand what makes up narrow band radio.

The encoded input signal is mixed with a constant frequency, known as the carrier. The resulting radio frequency (RF) signal is broadcast through an antenna. At the other end, the receiver picks up the signal through its antenna, and filters out the carrier frequency, leaving the original signal for further decoding.[Ref. 20]

An example of single-frequency narrow band radio is the common radio. It is the same type of radio you use to listen to your favorite music, news, or sports commentary. Radio stations (both AM and FM) use narrow band communications.[Ref. 20]

The Federal Communications Commission (FCC) regulates these frequencies and a license to operate a narrow-band transmitter is required. The licensing process is very time consuming and can take as long as 90 days to process. This time delay is required to assure that your system does not interfere with another system.[Ref. 20] Because of the way the FCC manages these frequencies, many radio and television stations can operate within their frequency allocation simultaneously and not interfere with other stations.[Ref. 6]

Since radio signals get weaker the farther you are from the transmitter, the FCC can usually assign one frequency to several stations, as long as they are in different parts of the country, far enough removed from each other that they won't interfere. This technique is often referred to as "spectrum re-use." The radio frequency spectrum is a scarce resource, so you can think of spectrum re-use as recycling for radio.[Ref. 6]

One of the concerns or problem with a narrow band wireless LAN is the risk of interference.

Narrow band frequencies interfere with each other. As a result, each narrow band radio must be individually licensed by the FCC to operate at a certain frequency and in a particular location. Neither the frequency nor the location can be significantly altered without violating the terms of the license.[Ref. 20]

As a licensed/registered user of a narrow band system, you have legal rights to use that frequency that has been assigned for your use. Narrow band radio requires a "guaranteed 'clear frequency.'"[Ref. 22] If your system experiences interference, the FCC will take whatever actions necessary in order to protect your

usage rights. The FCC, if it feels that it is necessary, will issue a "cease and desist" court order to individuals responsible for the interfering signal.[Ref. 23] One problem or concern a network manager may have is the time that it will take once an interference problem is identified and the time it takes before the FCC becomes involved. TABLE 3 represents some common frequency allocation.

START OF RANGE (MHz)	END OF RANGE	
0.00005	0.00006	Electrical current, wall outlet
0.2000	0.217	CarrierNET (Carrier Current Technologies)
0.5300	1.600	AM radio
87.900	108.000	FM radio
470.000	512.000	TV channels 14 to 20
512.000	608.000	TV channels 21 to 36
608.000	614.000	Radio astronomy (one of several channels)
614.000	806.000	TV channels 37 to 69
824.000	849.000	Cellular phones, mobile radio networks
869.000	894.000	Cellular phones
896.000	901.000	Cordless phones
902.000	928.000	WaveLan (NCR Corp.) ARLAN 600 series (Telsystems SLW) RadioLink (California Microwave) Lawn (O'Neill Communications)
960.000	1,215.000	Air Traffic (worldwide)
1,559.000	1,625.500	Air Traffic (worldwide)
1,850.000	1,990.000	Data-PCS frequency (proposed)
2,400.000	2,450.000	Amateur radio, radiolocation
2,400.000	2,483.500	RadioLink (California Microwave) FreePort (Windata Inc.)
2,700.000	2,900.000	Doppler weather radar
5,725.000	5,850.000	FreePort (Windata Inc.)
18,000.000	19,000.000	Altair (Motorola) FCC Digital Termination Service (DTS)
344,827,586.207		InfraLAN (InfrLAN Technologies Inc.) (870 nanometers)
389,610,386.610	491,803,278.689	Visible red (770 nm. - 610 nm.)
625,173,913.043	789,473,684.211	Visible violet (460 nm. - 380 nm) (N.M.)

TABLE 3
FREQUENCY ALLOCATION
Source from [Ref. 15]

b. Advantages and Disadvantages of Narrow Band Radio

One clear and undisputed advantage of all VHF/UHF radio-based LAN systems is their ability to penetrate office walls, thus making it possible to network multiple rooms within a building.[Ref. 6] It should be noted that different radio frequencies have different penetrating abilities and therefore all radio based LANs do not act the same. For example:

. . . low-frequencies radio waves bend right around hills and buildings and penetrate deeply into structures, higher frequencies tend to travel in a line-of-sight fashion, with less ability to penetrate walls and other surfaces.[Ref. 6]

These characteristics of radio frequencies (RF) can be an advantage as well as a disadvantage in certain office arrangements. A disadvantage would be in buildings that have a lot of walled office spaces. The Narrow Band (NB) wireless LANs that use higher frequencies may not be able to penetrate all of the office walls and connect the users to the network. As a result, distance limitations exist for the NB high frequency RF traveling through numerous walls.

Another disadvantage deals with the problem of multi-path interference. This interference is experienced by all of the radio frequency wireless LANs and is caused when the transmitting signals are reflected off walls, ceilings, and other objects and arrive at the receiver at different times.[Ref. 22]

The limitations of distance is an advantage for the security of high frequency NB radio. Its signals will not stray far from the building and the frequencies entering the building will not travel far enough to interfere with another network.[Ref. 6]

c. Product Evaluation for HF Wireless Networks

Motorola Inc. is the only company at this time that is producing a single, narrow-band, high-frequency wireless system. The product is the Altair Plus II™ Wireless Ethernet LAN. It is a hub-based system, and it operates on an Ethernet network using two 10 MHz wide frequency bands between the 18-19 GHz range. The following are the allocated frequencies:

1. 18.825 GHz ± 5 MHz and 19.165 GHz ± 5 MHz
2. 18.835 GHz and 19.175 GHz
3. 18.845 GHz and 19.185 GHz
4. 18.855 GHz and 19.195 GHz
5. 18.865 GHz and 19.205 GHz

Motorola has obtained licenses for the 18 GHz operation in all metropolitan areas with populations above 30,000 in the United States, the customer does not have to deal directly with the government, nor wait for government approval to operate equipment.[Ref. 24]

The user still needs an FCC license to operate the equipment; however, all the user has to do is to complete a registration card and call the Motorola's Frequency Management Center (MFMC) to determine the frequency setting to use. After that, the user can immediately begin using the equipment. Motorola handles all of the FCC license paper work for the user. If or when the user moves the equipment to a different area/location and before it can be used again, he **must** call MFMC in order to comply with FCC requirements and, if necessary, obtain a new frequency setting for the equipment.

The radio signalling rate for the ALTAIR PLUS II is 15 Mbps. This means that 5 Mbps is used for signal encryption, error correction, etc. This overhead does not interfere with the compatibility with an Ethernet system. In practice, the maximum throughput of the system is rated 5.7 Mbps. It has an operating distance of about 150 unobstructed feet. This distance shrinks ". . . to 40 feet when passing through three plaster-board walls." [Ref. 18] Motorola markets the ALTAIR PLUS II to cover an area between 5,000-50,000 square feet. (depending upon building construction).

The equipment for a work-group or "microcell" consists of two types of hardware: a Control Module and one or more User Modules. The Control Module (CM) can handle a maximum of fifty users/devices and each User Module (UM) can accommodate up to eight users/devices. A configuration example in the extreme sense

would be for a network to have one CM with fifty UMs. The CM ". . . can be connected to an Ethernet server or wired network." [Ref. 24] The CM has two purposes. The first is to route data between the UMs, and the second is to route data to and from a server or wired LAN. In both roles, the CM acts as a bridge. This approach keeps superfluous traffic off of the network backbone and thus, theoretically, improves both the network and the microcell performance. A typical office configuration of the ALTAIR PLUS II is depicted in Figure 5.

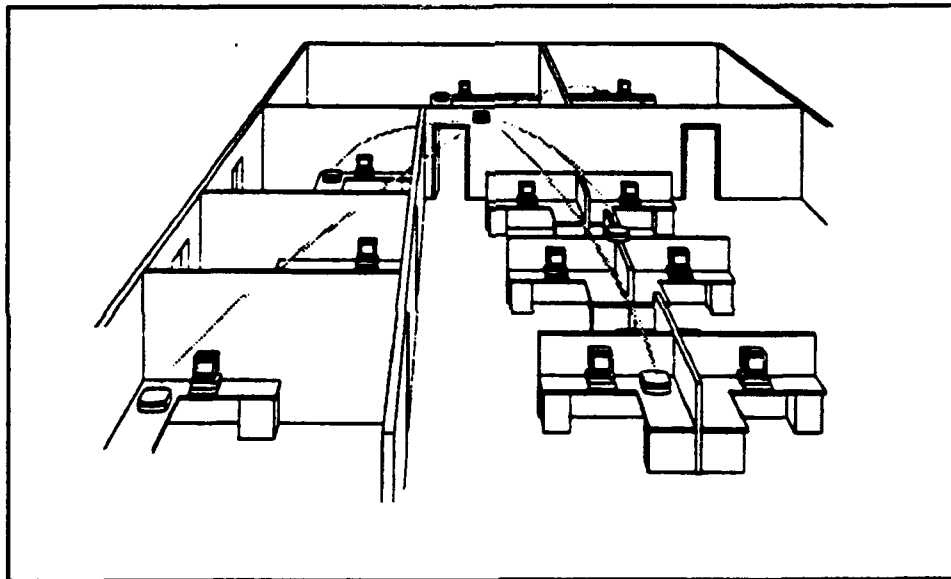

Figure 5
ALTAIR PLUS II OFFICE CONFIGURATION
Source [Ref. 24]

The ALTAIR PLUS II system is flexible and expandable. When more work groups or microcells are required, additional CMs and UMs can be used and

operated by using non-overlapping frequencies. Figure 6 illustrates a network utilizing multiple workgroups/microcells.

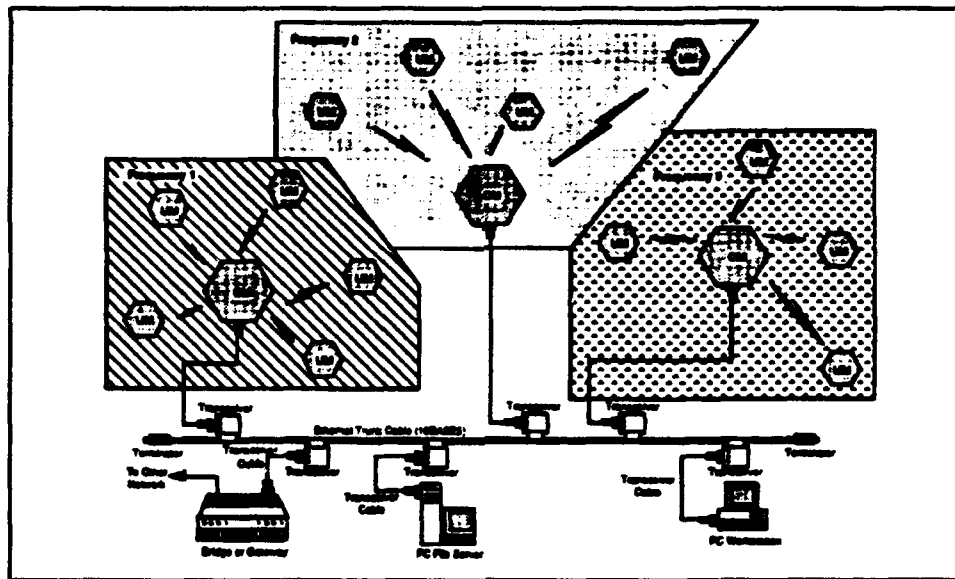

Figure 6
MOTOROLA MICROCELL CONFIGURATION
Source [Ref. 24]

The ALTAIR PLUS II system provides several levels of security for the user. The first is the operating frequency itself - since the ALTAIR operates in the 18 GHz range, it is not "susceptible to monitoring by conventional radio receivers and scanners which operate around 2 GHz and below." [Ref. 24] If a hacker was intent upon tapping into the network, he would probably have to have racks of expensive equipment along with a large conspicuous receiving dish antenna. [Ref. 24]

The second level of security for the ALTAIR PLUS II system is the dynamic antenna selection. This antenna configuration allows only a random portion

of the entire data transmission to be received at a given location. The antennas can continually change their transmission paths; thus, someone "would have to change positions several times per second to intercept a complete data transmission." [Ref. 24] In addition, the data is contained in a unique frame structure and is scrambled. Any received portion of the transmission by an unauthorized individual would be meaningless.

Lastly, "the CM contains a restricted access registration table listing the unique identifier addresses of only those UMs permitted to communicate with it." [Ref. 24] It would not be possible for someone to intercept the data transmission by using an unauthorized UM. To change the table listing requires physical access to the CM or access to the security authorization listing at a SNMP management station. In addition, the Altair system is a medium to connect point "A" to point "B" and if the LAN encrypts data over wire, it will be transparently transmitted through the microcell. [Ref. 24]

The overall cost-per-node of the Altair Plus II is competitive with that of other products from other top performers of wireless networks. The Control Module lists for \$4,995. There are two models of the User Module from which to select. The 10BASE-T model lists for \$1,195, and the 10BASE-2 and 10BASE-5 models lists for \$1,295. As an example, Figure 7 displays the cost of a Control Unit and the 10BASE-T

User Modules with eight devices attached. The cost of a UM (\$1,200) is added at 1, 9, and 16 number of nodes. Figure 7 does not, however, reflect the cost of the network interface card nor the eight-port hub that is required to connect multiple users to a UM. It should be obvious, but it needs to be mentioned that the cost-per-node of the wireless network will decrease with every device that can be attached to a UM. With a fully loaded system (1 CM, 7 UM, and 50 PCs/Printers/etc.), the cost-per-node reaches \$250.

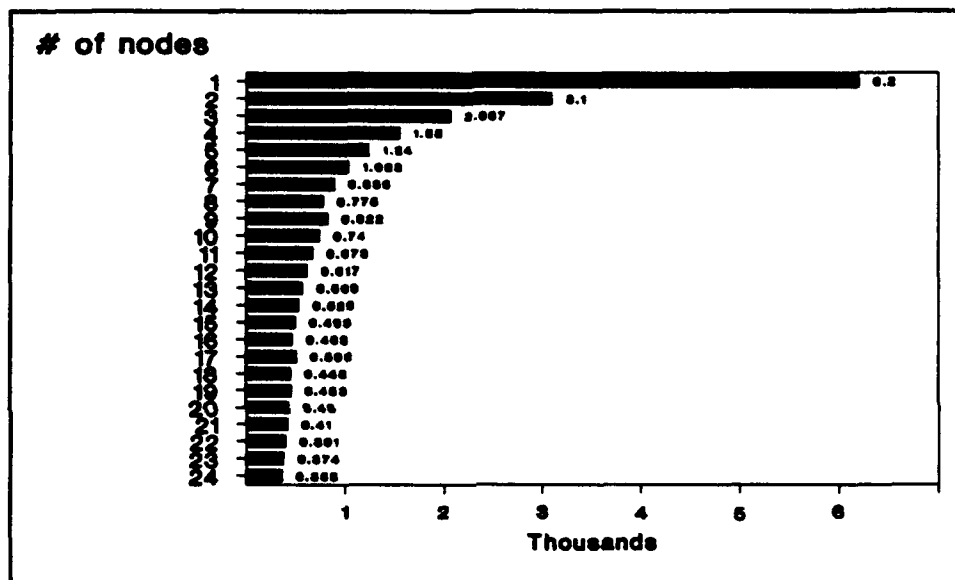

Figure 7
 COST PER NODE FOR THE
 MOTOROLA'S ALTAIR PLUS II
 Source from [Ref. 24]

It is not straight forward to calculate cost-per-node for the ALTAIR PLUS II wireless network because of the different configurations available to this hub-based system. As previously mentioned, the Control Module must be apportioned

over the number of nodes in the microcell (1 to 50), and the User Module can link up to eight devices/nodes. An amortized cost comparison between the ALTAIR PLUS II and the cost of installing cable is illustrated in Figure 8. The amortization of ALTAIR system, for this illustration, is comprised of one CM and one UM with eight devices over 1, 2, 3, 4, and 5 year periods. The cost per node per month is \$64, \$32, \$21, \$16, and \$13 respectively.

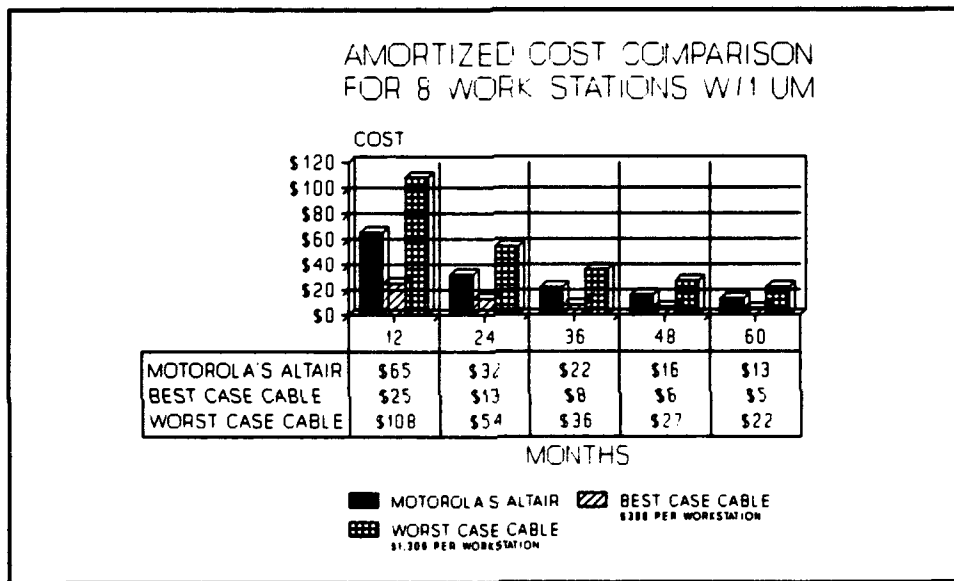

Figure 8
AMORTIZED COST COMPARISON FOR
MOTOROLA'S ALTAIR NETWORK
Source from [Ref. 24]

There are three concerns the author has about the ALTAIR PLUS II product. First, because it is a hub-based system, the systems topology "... lends itself to the typical open-plan, cubical-populated office environment." [Ref. 6] This restricts

the mobility of the network. The second concern deals with connecting up to eight thin coax cables from the different devices (PCs, Printers, etc.) to the User Module. If the product is used in an open-air, cubical, cluster type environment, the problem is the user may not be able to take full advantage of the multi-port configuration for the UM. Office arrangements vary and there may not be eight devices within a cubical cluster. If the network manager tries to pull cable to fill the ports, the network fails to be wireless and cable begins to emerge under the floors (carpeting) and/or up and down the ceiling. The last concern deals with the distance capacity of the ALTAIR system. As I mentioned earlier, its operating distance in an open-air environment is a 130 to 150 feet radius, but if it has to go through three dry-walls, its operating distance is reduced to a 40 feet radius. Motorola, in defense of that situation, states that because of the 18-19 GHz signal and the low signal strength, the signal "drops off rapidly beyond a certain distance, avoiding conflicts with adjacent microcells." [Ref. 6]

3. SPREAD SPECTRUM RADIO-BASED LANs

a. Spread Spectrum Overview

Spread Spectrum is difficult to grasp at first, but by understanding the fundamental ideas, the reader will be better prepared to understand the following discussion. The best definition for Spread Spectrum is by Fred P. Heiman:

Spread Spectrum technology is a technique for uniformly distributing the information content of a data signal over a frequency range considerably larger than that normally required for robust transmission of the data. On the other hand, *narrow band* transmissions occur only within a tightly restricted frequency range.[Ref. 25]

Put another way, the spread spectrum system is a technique by which a transmitted signal is literally ". . . spread over a wide frequency band, much wider, in fact, than the minimum bandwidth required to transmit the information being sent." [Ref. 26]

The advantage of spreading the signal without appending any additional data causes a significant amount of redundancy to be added to the signal. This redundancy allows ". . . the data to be recovered in the presence of strong interfering signals, such as noise, single tones, and jamming signals" [Ref. 25] even if the transmission frequency are known. In addition, it also ". . . allows the power of each transmission to be lower, making messages much more difficult to detect and intercept." [Ref. 27] If anyone were to scan through the frequency bands with a conventional receiver, he would not be able to detect any signal because there is not much of a signal at any given frequency and a signal does not reside on a single frequency. [Ref. 6] Moreover, two or more spread spectrum systems can operate in the same frequency range with different spreading codes and appear invisible to the other systems. [Ref. 6]

Even if a spread-spectrum type of receiver were used, the signal would still be almost impossible to detect unless you knew (and used) the specific spreading code used to transmit the signal.[Ref. 6]

This radio frequency technology, as mentioned before, is newer than single frequency radio, and it was developed in World War II to overcome enemy jamming and eavesdropping of military communications. Since its development, it has been almost exclusively used by the government or military. In fact, it was illegal for civilian use until the FCC, in 1985, approved three frequency bands for unlicensed spread spectrum use.[Ref. 27] Spread spectrum is used today in ". . . communications, data transmission, message privacy, signal hiding, and position location." [Ref. 26] For example, NASA has been using spread spectrum communication to communicate with its deep space satellites ". . . where data signal levels are extremely weak and the atmosphere is filled with interfering signals of many origins." [Ref. 25]

Spread Spectrum (SS) is the last of the three technologies for wireless LANs. There are two technologies for spread spectrum: *Frequency Hopping* and *Direct Sequence*.

(1) *Frequency Hopping*. In frequency hopping (FH), the transmitting radio unit switches frequencies very rapidly, usually measured in milliseconds, in a predetermined but cryptic sequence. The receiving units are tuned to the transmitter's sequence and skip frequencies at the same time. A disadvantage to FH is that it is

susceptible to the same frequency jamming problems as standard radio, but the signal is still more difficult to intercept.[Ref. 28] In addition, because of the full-strength signal being sent at each of the frequencies, FH is subject to the same interference problems as a standard radio signal.

To further understand this technique, Figure 9 shows "... that each bit of a data is broken into several 'chips' where each chip is represented by a different tone in the spread spectrum band." [Ref. 25] For example:

A chipping code comprised of a 10-bit number would be said to have 10 "chips" - each bit is referred to as a "chip." The effect of the chipping code is to spread the signal in direct proportions to the number of chips used. Therefore, a 10-bit chipping code would spread the signal to a frequency range that's 10 times what it would otherwise be.[Ref. 6]

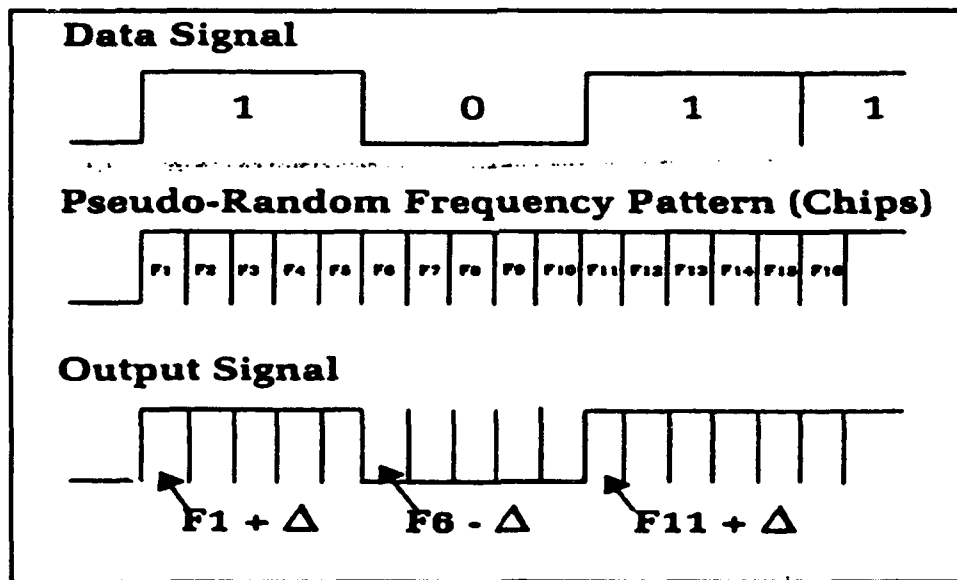

Figure 9
FREQUENCY HOPPING
 Source [Ref. 25]

The chipping pattern before being modulated by the signal is "a pseudo-random sequence of tones uniformly distributed throughout the band, simulating white noise (or random interference) over the spread spectrum band; it contains no information." [Ref. 25] Information is introduced to the chipping sequence by mixing or modulating the data signal with the chipping sequence. [Ref. 25] For the information to be received, the radio receiver must know the transmitters chipping code/sequence and the frequency and timing of the frequency hops.

(2) *Direct Sequence Coding.* Direct Sequence Coding is the other technique used in spread spectrum. In this technique, as seen in Figure 10, the binary digital signal (chips) is mixed or modulated with a pseudo-random binary string.

The sequence is combined (XORed) with the data signal, producing a direct sequence signal whose chipping rate is significantly higher than that of the data rate, spreading the signal over a frequency range larger than that required by the data signal alone. [Ref. 25]

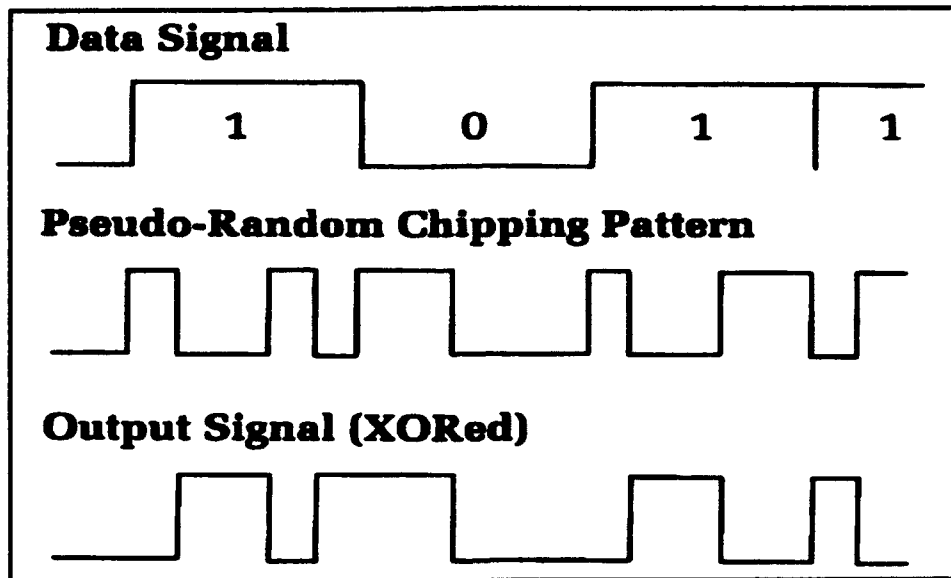

Figure 10
 DIRECT SEQUENCE
 Source [Ref. 25]

The receiver for a direct sequence radio is similar to the receiver of the frequency hopping radio, it must know the chipping sequence and data transmission timing. Frequency hopping and direct sequence produce a frequency spectrum similar to that in Figure 11.[Ref. 29]

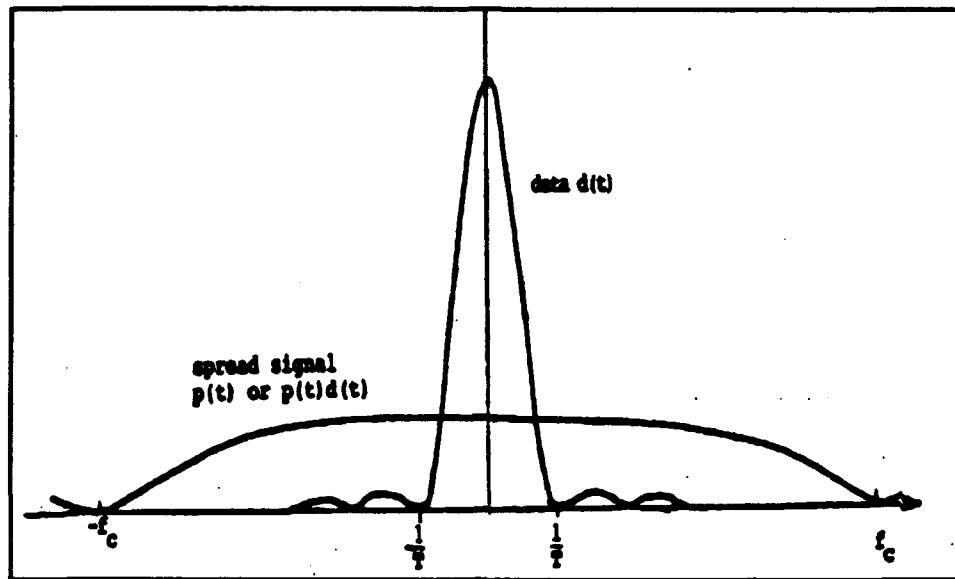

Figure 11
POWER SPECTRUM OF DATA AND OF SPREAD SIGNAL
 Source [Ref. 29]

To better understand the principles of direct sequence coding, the following explanation by Michalski may be useful:

... direct sequence technology diffuses the energy over a larger portion of the spectrum. It's like taking the water from a garden hose and sending it through a sprinkler: The same amount of water comes out, but in many small streams that are harder to intercept than one big one. With DS, not every sprinkler hole is active to send each message; transmitters and receivers agree on which of the holes will be carrying their particular signal, and monitor those exclusively. The set of sprinkler holes to watch at any given time is called the chipping sequence, because the information is broken down into "chips" that are spread over the appropriate frequencies. Now, other receivers and transmitters could be using several of the same holes, but few are likely to use the same subset. That is, by focusing on a specific subset of the frequencies, the receiving set can detect a signal amid the noise generated by other transmissions that share some of the frequencies.

b. Product Evaluation for Spread Spectrum

Spread spectrum is growing in popularity among the communication industry. There are many products emerging in wireless LANs, but currently there are only two that are truly top performers. They are the NCR's product WaveLAN and Windata's product FreePort. The topology and operation of these two products are peer-to-peer and hub-based, respectively.

(1) *NCR WaveLAN.* NCR's WaveLAN is the only true wireless LAN available. It is the only one because of its peer-to-peer topology that does not have the user connecting the Network Interface Card (NIC) to a shared or hub antenna. As shown in Figure 12, "WaveLAN itself is wireless, but it is fully wire-compatible. This allows you to branch off from your existing network. . ."[Ref. 30] The WaveLAN package includes its own NIC with an integrated radio transceiver built in, a small (4 X 4 X ½-inch) omnidirectional antenna, 5 feet of cable, and accompanying LAN driver software. No other devices are connected to the antenna.

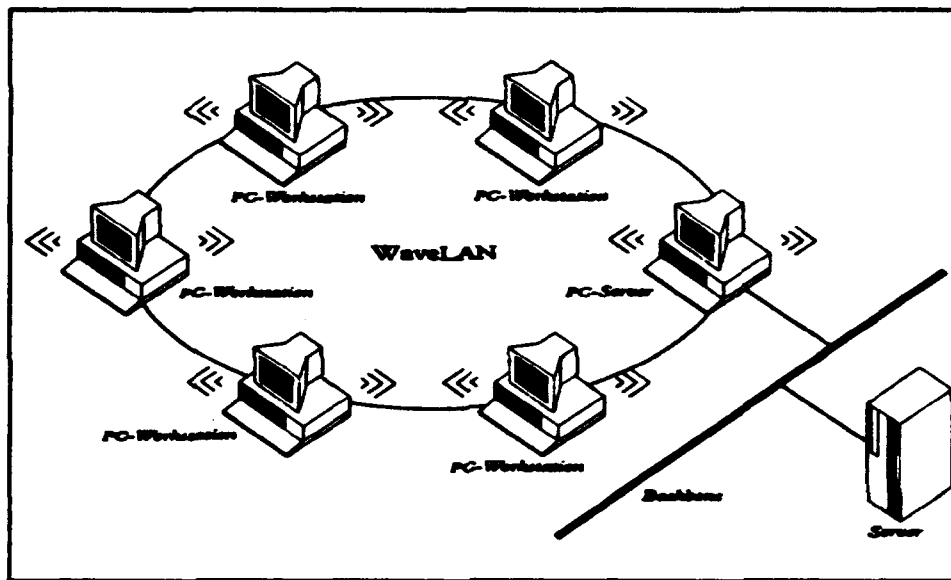

Figure 12
 WaveLAN, the wireless LAN that can live with wires
 Source [Ref. 30]

The configuration of the WaveLAN is to form wireless LAN segments.

A wireless LAN segment is formed by a group of WaveLAN NICs set to the same LAN segment ID that are within radio range of each other. A wireless LAN segment can cover a normal departmental area with wired LAN link reliability and without concern for antenna orientation or placement (this is typically 50,000 square feet with typical connection distances of 200 feet). A maximum coverage area in an open environment is 500,000 square feet with connection distances of 800 feet.[Ref. 30]

The system operates in the 902-928 MHz range. This is the lowest range of the three ISM^c bands. This band is approved by the FCC for unlicensed operation of spread-spectrum.[Ref. 6] This band, however,

... is both fairly narrow and crowded with such devices as store security systems, paging systems, etc. The other two bands, however, offer sufficient bandwidth to transmit data at multi-megabit data rates and are virtually free of interference from other devices.[Ref. 31]

Its medium access control is compliant with csma/cd, the IEEE 802.3 standard. The number of nodes that can be placed upon the system is unlimited, but the performance degradation caused by more nodes being added will be the limiting factor of nodes to the network manager.[Ref. 6]

The performance is rated at 3.3 Mbps and operating distance of the WaveLAN will depend upon the environment. The product has been marketed to operate as far away as 800 feet with line-of-sight (LOS). The typical operating distance in an office area is advertised at 200 feet, and if it has to go through walls or partitions - it goes down to 100 feet. In addition, the WaveLAN card, "with an optional directional antenna, [allows] buildings up to five miles (LOS) apart" to be connected.[Ref. 30]

^c ISM is the acronym for Industrial, Scientific, and Medical. ISM bands will be discussed in the Section C of Chapter III.

The security offered by NCR are broken into a three-layered approach:

- **Spread-Spectrum technology:** A transmission method that is both hard to intercept and jam.
- **Network Identification:** Each WaveLAN NIC has a unique software identification number that is entered at the time of installation. This segregates other WaveLANs in the area, and restricts entry into the network by using an unauthorized WaveLAN NIC.
- **Data encryption:** This is an optional chip that is installed on the NIC and provides Data Encryption Standard (DES) security. (Note: The chip is not authorized for secure data communications at U.S. government installations.)

The cost-per-node for the WaveLAN is relatively easy to calculate because there are almost no other costs to include for the system. The cost of the system is \$795 and unlike other wireless systems, this price **does** include the NIC. The optional DES chip is an additional \$95 per NIC. Monthly amortization cost of the WaveLAN, without the DES chip, for out years one, two, and three are \$66.25, \$33.13, and \$22.08, respectively.

The Aeronautical Systems Division at Wright-Paterson Air Force Base at Dayton, Ohio contracted with Frontier Engineering, Inc. to conduct an evaluation of the NCR's WaveLAN wireless network. The evaluation was completed on December 19, 1991. This evaluation is included in the Appendix-B.

(2) *Windata's FreePort.* At 5.7 Mbps, FreePort is the fastest Ethernet (IEEE 802.3) ready wireless LAN on the market that uses spread spectrum. Windata, Inc. was founded in 1990. It introduced the FreePort (hub-based system) in late 1992. Up until that time, spread spectrum transmission speed was no better than 3.3 and a throughput of 2 Mbps. That low speed was the major disadvantage in the use of spread spectrum wireless LANs. The speed of the FreePort makes it equal to or better than that of some wired systems. In fact, the FreePort system, when tested by the Naval Medical Information Management Center at Bethesda, Maryland in early 1993, was reported to outperform their UTP wired network system.[Ref. 32]

Several unique features that appear to separate the FreePort from other radio wireless LANs are: 1) its solution to turn the near-far and multipath problems into an asset for the system^d, 2) FreePort is able to transmit "... through 10-12 common constructed office walls"[Ref. 31], and 3) has an operating distance of 260 feet. Compared to WaveLAN, WaveLAN when operating through a maximum of 3 common walls is only able to operate within a 40 foot radius. This operating distance has demonstrated the superior performance of the FreePort.

The basic design of the FreePort includes a transceiver, and in order to propagate the cost, a multi-user interface option allows eight users share one

^d The multipath and near/far problems will be explained in Chapter IV.

transceiver. In addition, the user can select from two FreePort Hubs. One supports up to 32 transceivers and the other supports up to 62 transceivers.[Ref. 33]

Figure 13 provides an example of the design of the FreePort network.

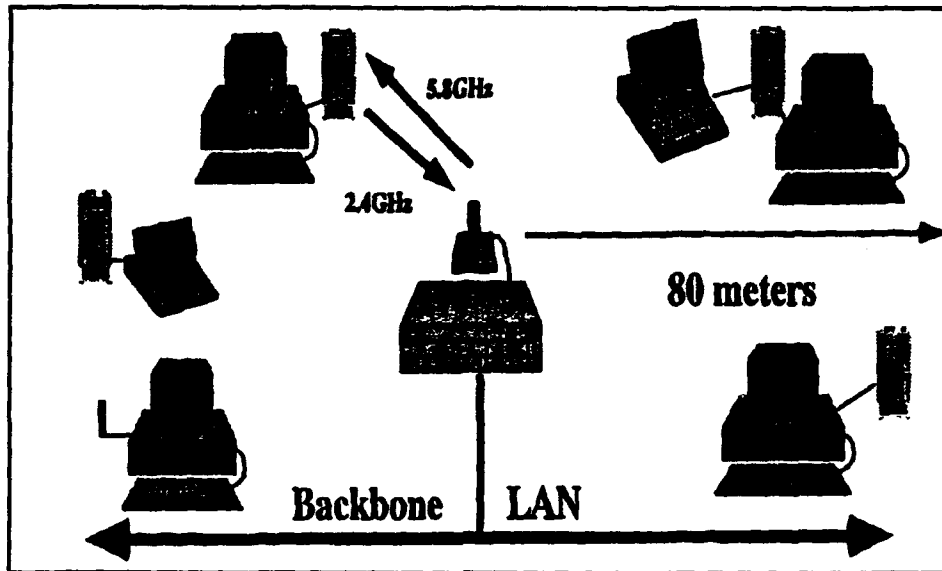

Figure 13
FreePort Architecture
Source [Ref. 33]

The following features of the FreePort Wireless are[Ref. 33]:

- Throughput of up to 5.7 Mbps
- 260-foot (80-meter) transmission distance
- Accommodates up to 256 active users on as many as 62 Wireless Transceivers
- Industry-standard IEEE 802.3 interface
- Industry-standard SNMP network management with ability to run existing network management systems
- Unlicensed spread-spectrum radio communications--robust and secure

- Connection between wired and wireless LANs
- Communications reliability consistent with wired LANs
- Cost per-node comparable to wired LANs
- Installation by non-networking professionals
- Transparent to existing networks, no alterations to NIC devices or drivers.

Windata addresses security in several different ways. First, it uses trellis encoding with Code Division Multiple Access (CDMA). The properties of CDMA include anti-jam and low probability of intercept (LPI).[Ref. 34] This is followed by a "registration process whereby a wireless transceiver station is only able to join a wireless network if it has had its serial number entered into the hubs access list." [Ref. 33] Finally, it uses direct sequence spread spectrum transmission with a chipping rate of 32-bits per baud. This rate is the highest in the industry. As a follow on:

The reality of the situation is UTP wired networks are actually unintentionally designed phased array antennas radiating the baseband, unencoded data. It would be easier to capture data off the UTP wired network than to try to capture and decode the RF signals.[Ref. 33]

The cost of the FreePort system is as follows: the hubs that support the 32 and 62 transceiver lists for \$4,695 and \$5,895, respectively. The cost of the transceiver lists for \$995 and the eight user interface lists for \$595. Just like all other hub based wireless system, it is difficult to formulate a true and accurate cost of the FreePort. For

a full 62 transceiver system with 256 users attached, the monthly amortization monthly cost of the FreePort per node for year 1, 2 and 3 are \$34, \$17, and \$11, respectively. For a 32 transceiver system with 256 users attached, the monthly amortization monthly cost of the FreePort per node for year 1, 2 and 3 are \$17, \$8.5, and \$5.7, respectively.

C. STANDARDS FOR WIRELESS LAN

The first wireless medium (infrared) was introduced around 1987, and it emulated a Token Bus LAN. This was the first wireless activity for the IEEE 802.4 working group. The IEEE 802.4 working group works exclusively with establishing standards for the Token Bus networks.

During the early 1980s and through 1990, the interest of the IEEE 802.4 working group expanded its standardization control for providing standards for infrared wireless networks and began researching the modulation techniques of the non-licensed radio-frequencies for wireless LANs. The group's interest for infrared declined while Radio Frequency (RF) grew in popularity. As a result of these new interests, the working group also began conducting studies for understanding the characteristics of propagation and the noise in buildings.[Ref. 35] The IEEE 802 project lobbied the FCC for additional bandwidth in order to research and provide wireless standards. As a result of those efforts, in 1985 the Federal Communication Commission (FCC) changed the agency's Part 15 rules by allowing ". . . unlicensed operation of spread-

spectrum radio devices on three frequency bands that had been used for industrial, scientific and medical applications (and are thus commonly referred to as the 'ISM' bands)."[Ref. 35] These frequency bands are:

- 1) 902 - 928 MHz,
- 2) 2.4 - 2.5 GHz,
- 3) 5.725 - 5.875 GHz.

In July 1990, the IEEE 802.4 working group determined that establishing a wireless standard by their group was not feasible, and the IEEE 802 Executive Committee made the following statement:

... the group had come to the conclusion that the Token-Passing bus protocol was not suitable for controlling a radio frequency spectrum. The Executive Committee of IEEE Project 802 decided at the same meeting to establish Working group IEEE P802.11 with the charter to make an access protocol and medium control specification suited for radio.[Ref. 35]

As a result the IEEE P802.11 is the working group for wireless LANS and is a part of the IEEE Standards project 802. The "P" in front of the 802.11 means that the standard is proposed and not yet a true standard. The P802.11 "is recognized as the focal point for the development of Local Area Network standards and it is respected for

its expertise and productivity within the IEEE.”[Ref. 35] The goal of the working group, as Figure 14 displays, is to have a wireless standard by late 1994^e. [Ref. 35]

ESTABLISHMENT OF ARCHITECTURE	NOVEMBER 1992
FIRST DRAFT STANDARD	JULY 1993
FINAL DRAFT STANDARD	MARCH 1994
SUBMISSION TO ISO/IEC	JULY 1994
FIRST TEST SUITES	NOVEMBER 1993
FINAL DRAFT TEST SUITES	JULY 1994
SUBMISSION TO ISO/IEC	NOVEMBER 1994

Figure 14
GOAL OF IEEE P802.11 WORKING GROUP
Source from [Ref. 35]

D. HEALTH ISSUES

Thus far in the thesis, I have addressed only positive comments about Wireless Local Area Networks (WLANs). Are there disadvantages or concerns that a system manager or a user may have in the operation of a WLAN? If so, what are they?

“The negative aspect of wireless network technology, radio frequencies (RFs) or microwaves, is high-level electromagnetic fields (EMFs).”[Ref. 36] This potential problem of RF and EMF surfaced when allegations were published that stated

^e Note: At the time of this thesis, only a draft standard for the IEEE P802.11 was available and it is included as Appendix-C.

that cellular-equipment caused cancer to its users. This caused the federal government to take two actions: it recommended caution when using the equipment, and it recommend additional studies on WLANs.[Ref. 36]

The suspected health problems associated with low-level EMFs from high-voltage power lines as identified in Europe and the United States include leukemia, other cancers, and miscarriages. These accusations, however, could not be substantiated and some health officials found no correlation between the two.

The editor of Microwave News, Louis Slesin has said: "Here we are introducing a whole new source of radiation into the office without really looking at the potential danger." [Ref. 36] On the surface, this statement of not looking at the danger of EMF would appear to be valid. Futhermore, Jerome Beers, a radiologist at Shields Health Care Group Inc. of Brockton, Massachusetts, implies research on EMF has been done, and a possible cover-up on the research of EMFs by the Environmental Protection Agency took place. Beers said: "The Environmental Protection Agency, which in the early 1980s did seem to have some interesting research, had its funding removed." [Ref. 36] In addition, Beers continues by saying:

Some EPA staffers [in 1990] came up with a fairly large document with the conclusion that electromagnetic and radio-frequency fields are probable or possible carcinogens, respectively, . . . [Ref. 36]

"Their findings were circulated for internal review but, according to Microwave News, they were suppressed." [Ref. 36]

The actual power wattage for wireless communications (cellular and wireless LANs) vary between vendors. The FCC has set a maximum power limit for the technology. "Car phones can transmit at up to 3 watts, while hand-held models are limited to 0.6 watts. Wireless LAN products, however, are allowed up to 1 watt." [Ref. 36]

Although the reported risk of operating a cellular phone or a wireless LAN is less than that of driving a car, agencies in the United States and the former Soviet Union believe "certain electromagnetic frequencies can create emotional or mental states, such as irritability or depression." [Ref. 36]

Only after studies are done and published on the possible hazards of EMF from RF will the industry's and the users' fear of the technology be eased.

IV. DESIGN CONSIDERATION FOR WIRELESS LANS: CASE STUDY^f

A. THE DESIGN

There are virtually unlimited ways an office or a building would be appropriate for a Wireless LAN. The following scenario is provided as only an example of a particular situation along with a viable solution. The scenario's authors are Anthony Chua, LT Steve Powell, LT Jamel Weatherspoon, and the author. This scenario's basis is built upon the LAN standards by the Naval Medical Information Management Center, that standard being that all naval medical commands use Ethernet networks.

B. THE SCENARIO

The Navy's flag-ship hospital, Bethesda Naval Hospital, recently received certification from the National Register of Historical Places designating the hospital as a historical building. This certification was endorsed by a Congressional committee to preserve all historical buildings within the Washington D.C. area. Bethesda Naval Hospital was dedicated by President Franklin D. Roosevelt on August 31, 1942, and only until several years ago, this magnificent building remained in its original floor plan

^f This case study is in no way intended to endorse or to solicit business to any one vendor. It is only to show a situation where a wireless LAN might be suited to operate.

configuration. Two years ago, slight modifications to the building were completed. Additional modifications (more intense) were scheduled for the coming fiscal year. The original hospital spaces now support hospital administration. Patients who once occupied the World War II ward type spaces of the tower of Bethesda are now cared for in a modern 500 bed hospital that is adjoining the old hospital. The historical designation now prohibits any improvements or modifications to the building without the written approval of the Historical Foundation.

The Commanding Officer of the hospital has a computer background and advocates completely automating the hospital. He originally planned to connect *all* of the offices that have a PC, via cable, and make a Local Area Network (LAN). That way the command could enjoy the benefits that a LAN offers (i.e. E-Mail, Resource Sharing, etc.). After the CO's arrival, he discovered that there is a tendency within the command to move departments and personnel throughout the spaces of the command. For his LAN to work, he would have to run cable to all spaces (250 feet from north wall to south wall) and not just to the spaces that have PCs. This meant drilling holes in the walls as well as through the ceiling/floors. This was a safety issue because asbestos was used in the walls and ceiling. Because the hospital was certified as a historic building, any drilling of holes or modifications to the building would have to first be approved by the Historical Foundation. The CO was about to abandon the idea of a LAN for the

hospital because it would take several months before the Foundation would vote on the request and the cost of running cable to all spaces was going to be more than he wanted to spend.

The CO requested assistance from his computer department to help solve the problem of installing a LAN in the administrative spaces at the hospital. His Management Information System (MIS) officer suggested investigating the feasibility of using wireless LAN technology.

C. ADVANTAGES OF WIRELESS LANS FOR THE HOSPITAL

Wireless Local Area Networks provide many advantages over conventional hardwired LANs. These advantages include:

- **portability of nodes.** Individual computers and their transceivers can be moved without expensive cabling modifications. This permits easy addition of new nodes to the LAN and provides the capability of on-line LAN access almost anywhere within a building.
- **faster data rates.** Data rates, in some cases, are greater than rates attainable through hardwired LANs using dedicated cables.
- **economic savings.** Wireless LANs eliminate or significantly reduce the cost of cable and cable installation labor. Typical direct costs for installing a hardwired node range from \$200.00 to \$1,000.00 including material and labor.[Ref. 37] If nodes need to be moved even occasionally, these costs can rapidly become excessive. In addition, indirect costs of lost productivity while a node is awaiting transfer to a required location or during the process of actual rewiring must be considered. Savings in this area are expected to increase as more wireless vendors introduce products. "Wireless manufacturers have currently calculated this break-even cost and price their units slightly lower than the cost of

physical cable. Savings are appealing but not fantastic. As more competition enters the arena, observers expect the cost of wireless units to drop." [Ref. 14]

- **increased reliability.** Network experts indicate that two out of three LAN hardware malfunctions result from cable or connection problems.
- **minimal modification to architectural structures.** Using wireless LAN technology reduces or eliminates the need for cable running across office floors and through walls. This is an especially desirable characteristic for buildings listed on the National Register of Historic Places or that present asbestos hazards when modifying walls and ceilings.

D. DISADVANTAGES OF WIRELESS LANS FOR THE HOSPITAL

Although wireless LANs enjoy many benefits over wired LANS, some LANs have weak points when compared with traditional LAN technology. These include:

- **inability to propagate through steel reinforced walls.** Some wireless LAN technologies are unable to transmit through walls. None of the wireless LANs can transmit through steel reinforced barriers.
- **FCC licensing requirements for some wireless LANs.** Microwave frequency LANs require FCC licensing.
- **possible health concerns.** Although most analysts feel that the radio waves transmitted by wireless LANs will not detrimentally affect human health, concerns exist and future research in this area is probably warranted.

E. COMPARING WIRELESS LAN TECHNOLOGY FOR THE HOSPITAL

In this scenario, Bethesda Naval Hospital selected Windata's FreePort™ Wireless Ethernet system. FreePort™ is a spread spectrum based system that provides the best mix of capabilities for the Naval Hospital's requirements. There are **three basic technologies** that represent the state of the art in wireless LANs.

First, there are systems that use **infrared light waves** for transmission. These systems enjoy the benefits of no inherent speed limitations and no licensing requirements, but are hampered by an inability to pass through office walls or obstructions. A direct line of sight (LOS) link must exist for the system to work.

Secondly, there are systems based upon **spread spectrum technology**. These systems permit signal transmission through walls and, sometimes, ceilings/floors as long as these boundaries are not steel reinforced. Additionally, they operate within three RF frequency bands (commonly called the ISM bands) that do not require FCC licensing (902 - 928 Mhz, 2.4 - 2.5 Ghz, and 5.8 - 5.9 Ghz).[Ref. 6] Traditionally, spread spectrum systems have suffered from low transmission data rates (1 to 2 Mbps), but FreePort™ advertises a maximum throughput rate of 5.7 Mbps. This substantially increased data rate, along with spread spectrum's natural anti-jam, low probability of intercept (LPI) capabilities, makes the FreePort™ system especially attractive. In addition, Windata's

FreePort™ is currently using one spreading code. Upgrading or customizing the system to use multiple spreading codes would make the system capable of applying Code Division Multiplexing (CDM) techniques. Thereby permitting simultaneous transmission by several users on the same frequency.

Thirdly, there are systems based on **microwave radio transmission** in the 18 GHz range. These systems are also capable of data transmission rates of 5.7 Mbps, and are capable of propagating through most indoor walls. Their major disadvantages include requirements for FCC licenses, higher cost, and shorter operating distances when going through walls.

F. SPREAD SPECTRUM TECHNOLOGY

The FreePort™ System uses direct sequence spread spectrum modulation techniques to break each bit in the data stream into 32 chips and broadcast them using frequencies spread across the entire available bandwidth.[Ref. 38] A spread spectrum transmission looks like background noise to receivers that do not possess the correct spreading algorithm, which makes eavesdropping difficult and the system less susceptible to interference.

G. RF PROPAGATION PROBLEMS

There are basically two types of RF propagation problems in a wireless LAN. One is the **multipath problem**. This problem is caused by multiple RF signals arriving at a receiver at different time intervals. An example would be "ghosting" or the multiple pictures that are seen on non-cabled televisions. The other is the **Near/Far problem**. Transceivers fade at long distances and dominate at close distances.

The most dominate RF propagation problem for an indoor LAN is the presence of multiple reflected signals. There are an infinite number of propagation paths from radio waves reflected off of walls, ceilings, and floors. The result of the multiple paths is multipath interference. Windata solved the multipath problem by applying "rake technology".[Ref. 33] Each antenna system in FreePort™ feeds eight receivers delayed in time by one chip period. The signals from each receiver are compared in a device called the correlator.[Ref. 33] The correlator forwards the sum of the eight strongest signals into the system.

The Near/Far problem is caused by competing transmitters where a nearby transmitter overpowers the signal of a far away transmitter and masks its signal. In the FreePort™ system each transmitter applies a "dynamic power algorithm".[Ref. 33] This algorithm allows the HUB (base station) to regulate transceiver output power, so the minimum required power is used to transmit a signal. Table 4 was assembled from the

information provided by Windata Inc., and is the system specification for the FreePort™.

OPERATIONS	SPECIFICATIONS
LAN INTERFACE	IEEE 802.3, 10 BASE T
MODULATION TECHNIQUE	DIRECT SEQUENCE SPREAD SPECTRUM (DSS) (CDM CAPABLE)
DATA TRANSMISSION RATE	12 Mbps AGGREGATE THROUGHPUT, 5.7 Mbps PER TRANSMIT/RECEIVE CHANNEL
FREQUENCY BANDS: HUB	TRANSMITTER 5.725-5.85 GHz RECEIVER 2.400-2.485 GHz NO LICENSING REQUIRED.
FREQUENCY BANDS: TRANSCEIVER	TRANSMITTER 2.4-2.485 GHz RECEIVER 5.725-5.85 GHz NO LICENSING REQUIRED.
BIT ENCODING	16 BPSK WITH TRELIS ENCODING (ERROR CORRECTION)
SPREADING FACTOR	32 CHIPS PER BAUD (CURRENTLY ONLY ONE CODE)
EFFECTIVE RADIATED POWER	DYNAMIC POWER ALGORITHM HUB (up to 1 W) TRANSCEIVER (.02 - 650 mW)
ANTENNA CHARACTERISTICS	HUB (360° COVERAGE) FOCUSED TO ± 30° ON THE HORIZON TRANSCEIVER (180° COVERAGE) FOCUSED TO ± 30° ON THE HORIZON
EFFECTIVE RANGE	80 METERS (263 FEET)

TABLE 4
SYSTEM SPECIFICATIONS
Source from [Ref. 33]

so one or two hubs connected to the net backbone on each floor would be adequate.

Cable losses are negligible and free space path loss is unavoidable.

V. CONCLUSION AND RECOMMENDATIONS

A. CONCLUSION

The vision of a WLAN has probably been on the mind of every system manager who has ever pulled a computer cable. That vision was manifested in the mid 1980s when the use of infrared light was first used to connect computer peripherals. For the past ten years, WLAN technology has made great strides in improving data transmission speeds, increasing reliability, and lowering unit costs. Corporate interest in WLANs and mobile communications has grown significantly over the last couple of years. The market is ready to grow exponentially in the next couple of years. The only thing that appears to be holding back the wide-spread acceptance of WLANs is the lack of standards for WLANs, which must be established by the IEEE committee.

There are three WLAN technologies from which a company may select. The three technologies are infrared, microwave, and spread spectrum. The advantages and disadvantages of the 3 technologies are compared and summarized in TABLE 5.

TECHNOLOGY	OPERATION	ADVANTAGES	DISADVANTAGES
Infrared lightwave (BICC)	Transmitting stations at each connected devices send infrared light beams to other stations. Beams can travel in line of sight, or be reflected off of building walls and ceiling. Beams cannot pass through walls.	.No inherent speed limitations .No licensing required .Excellent security	.Will not work in walled office environment .Distance limited to about 50 ft. .Only works with Token Ring Networks
Spread-Spectrum radio (Windata's Freeport LAN, NCR Corp.'s WaveLan)	Transmitting stations use low-power, wide-bandwidth radio signals spread across a frequency like 902 MHz, 2.4 GHz, and 5.8 GHz.	.Can transmit through walls (does not require line of sight) .Faster actual data throughput than cable (5.7 Mbps (Windata) .No licensing required .Excellent security .NCR can transmit and receive data, using special antennas, up to 5 miles	.FreePort's distance is limited to 80 Meters .Only works with Ethernet networks
Microwave radio (Motorola's WTN system)	Transmitting stations use one of several 10-MHz band at about 18 GHz. Regions are divided into cells that can range from 40 to 200 feet in diameter. Adjacent cells use different frequencies.	.No inherent speed limitations (system works at 15 Mbits/s and beyond) .No interference problems - FCC license required .Microwave can penetrate most indoor walls .Actual data throughput is 5.7 Mbps.	.Indoor distance is less than 150 foot diameter. .Licensing issues might restrict LAN users' freedom .Only works with Ethernet networks

TABLE 5
TECHNOLOGY COMPARISONS

As shown in TABLE 5 there is no one best solution for all office environments. An organization should thoroughly examine its current LAN operating system and evaluate its needs. It will then be able to select the technology that will best fill its specific communication needs.

1. THE WLAN SELECTION⁶

Based upon the LAN operating system, the initial selection process for choosing a WLAN will eliminate one or two of the technologies. For example, if a Token-Ring network is already in use, the only technology available is Infrared. Additionally, the selection must be made based upon the layout of the office environment. Gary Berline said:

The layout of your own office, and the way the users are organized into departments or workgroups, will also significantly narrow your options. A floor built with many supporting walls that separate members of a department may not allow the operation of any system besides WaveLAN [and FreePort]. A network situated near equipment that generates heavy electromagnetic transmissions in the range of 902 to 928 MHz calls for either Altair or InfraLAN. And any layout that requires communications beyond 80 feet, even with line-of-sight positioning, cannot count on InfraLAN [Infrared].[Ref. 15]

The selection is ultimately made after the careful evaluation of each product's advantages and disadvantages. In addition, an in-depth review of an

⁶ The best network operating system for any given environment depends on specific requirements of that particular environment. Therefore, the process of deciding which LAN system to use goes beyond the scope of this thesis and will not be discussed.

organization's current and future networking requirements will provide insight into which technology it should pursue.[Ref. 15]

B. OTHER MOBILE COMMUNICATION^a

1. OVERVIEW

There are three broad applications for wireless communications. They are ". . . in-building wireless LANs, in-building LAN links for mobile computers, and metropolitan area networks." [Ref. 6] This thesis has only covered in-building wireless LANs.

2. INTERNATIONAL MOBILE COMMUNICATIONS

In addition to the aforementioned applications, there are at least two organizations that are pushing for an international mobile communications system. The first organization making the push is Motorola. Iridium is the project's name and the proposed function of the project

. . . calls for 77 satellites to blanket the planet and provide point-to-point connectivity anywhere. The cost of this project is estimated at \$2.1 billion.[Ref. 39]

^a There are a variety of wireless communication products available today, but only a few are discussed in this thesis.

International Maritime Satellite Organization (IMSO) is the other organization that is pushing for an international mobile communications system. There are 64 member nations in the IMSO. Project 21 is the name of the IMSO project, and it ". . . would use 30 to 40 satellites and existing phone technologies"[Ref. 39] to provide international mobile communications.

One of the major obstacles of global mobile communications has been the setting of standards. As of the time of this thesis, no wireless standards exist in the United States nor in other developed countries.[Ref. 39] This lack of wireless standards will soon change in the U.S. and Europe as the IEEE 802.11 committee and members of the European community are in the process of establishing their own standards.[Ref. 39]

3. WIRELESS PBX

Wireless PBXs, just like wireless LANs, are capitalizing on the savings of not having to install cable to their equipment. The technology is a "scaled-down cellular system for inside buildings or enclosed public areas, such as train stations or malls." [Ref. 40] Wireless PBXs are also proving to be a more efficient way to do business. According to Richard Bretagne, chief information officer at Northwestern Memorial Hospital in Chicago:

Wireless will be a key technology for us in the future. When doctors and nurses get beeped on their pagers, they have to search for a phone. It's more efficient if they just answer the call.[Ref. 40]

Wireless voice communication (wireless PBX) was first marketed in 1992, and it is going to challenge network managers to stay abreast of the technology. The benefits of a wireless PBX to the managers are improved service and quality of communications.[Ref. 40]

C. RECOMMENDATIONS

The problems associated with RF WLAN in the past have been the slow transmission speed, high cost, questionable health/safety issues, and data security. Those problems do not exist as of this date.

Organizations are relocating 30-50 percent of personnel each year. With the current trends of downsizing the personnel force and 20-30 percent of the federal budget being cut, system managers need to find ways to make their organizations more cost efficient. Waiting several years for a WLAN standard is not the most economical approach an organization can pursue. Berline says:

. . . waiting for an industry standard to emerge is a luxury that few can afford. And if a given product suits your needs, you have little reason to wait. The technology may be new, but the promise is already there.[Ref. 15]

APPENDIX A

DEVELOPMENT OF A REQUEST FOR PROPOSAL¹

I. Hardware

A. Microcomputers

- 1. What is currently on hand (brand, configuration)?**
- 2. Additional workstations required for network:**
 - a. IBM Compatibility to be able to run which programs?**
 - b. How much RAM is required?**
 - c. Number of disk drives required:**
 - i. For security reasons, do you prefer no disk drives and an autoboot ROM chip?**
 - ii. If disk drives are required, what size and capacity? (360k, 720K, 1.2M, 1.44M)**
 - d. If a hard disk is required:**
 - i. Size (megabytes)**
 - ii. Mounted in what kind of microcomputer?**
 - iii. Formatted in which version of DOS?**

¹ This section is almost a direct quote from Schatt, Stan. Understanding Local Area Networks, Third Edition. Carmel, In.: SAMS, 1992: pages 369-379.

e. Monitors and monitor adapter cards required?

- i. Color or monochrome?
- ii. Capable of what resolutions?
- iii. What size?
- iv. Dual mode?
- v. Capable of running certain graphics programs?
- vi. Other features required?

f. Other I/O cards required?

- i. Parallel or serial cards and cables
- ii. Additional RAM cards
- iii. Multifunction cards
- iv. Accelerator cards
- v. Others

B. File Servers

1. Size required
2. Processing speed of file server
3. System fault tolerance (if required)
4. Number of tape backup units
5. Other features required

C. Bridges to other networks

1. Other networks to be connected
2. Adapter cards and cabling required
3. Software required

D. Backbone networks required to connect multiple bridges

1. Description of bridges to be connected
2. Processing speed required

E. Gateways to mini/mainframe environments

1. Local or remote connections
2. Protocols required
3. Number of concurrent sessions required
4. Terminal emulation required
5. Local printer emulation required
6. Amount of activity to be handled

F. Minicomputers

1. Currently on hand (brand, configuration)
2. Need to integrate information with LAN

G. Mainframe computer

1. Currently installed (brand, configuration)
2. Need to integrate information with LAN

H. Printers

1. Currently on hand (brands, buffers, accessories)

2. Additional printers needed for the LAN

- a. Speed required
- b. Type (laser, dot-matrix, etc.)
- c. Compatibility with which major printer drivers?
- d. Type of connection (parallel, serial)
- e. Length of distance from workstations
- f. Other special printer features
 - i. Special language fonts or downloadable fonts
 - ii. Near-letter-quality and fast dot-matrix modes
 - iii. Which workstations/areas will need to access which printers?
 - iv. Any unusual printing requirements (color, multiple specific accounting forms, etc.)? copy,
 - v. Do any software packages that will be on the network require a specific printer? network

I. Modems

- 1. Currently on hand (brand, speed, special features, etc.)
- 2. Needs for additional units with LAN
- 3. Transmission mode required (simplex, half duplex, full duplex)
- 4. Interconnections required (point-to-point, multiple, drops)
- 5. Special features needed
 - a. Auto-dial
 - b. Auto-logon
 - c. Auto-answer
 - d. Other

J. Plotters

- 1. Presently on hand (brand, configuration)

2. Additional units required

- a. speed**
- b. Number of colors**
- c. Compatibility with which major brand?**
- d. Programs to drive plotters?**

K. Optical scanners

1. Currently on hand

2. Additional units required

- a. Speed**
- b. Which formats will be scanned?**
- c. Which programs will need access to this data?**

L. Other hardware required

1. Cash registers (for collection systems within medical facility)*

- a. Type of connection (serial, parallel)**
- b. Compatibility with which accounting program?***

2. Badge readers (for closed-shop environment)*

- a. Will employees clock in and out of several jobs for the same day?**
- b. Does this information have to be interfaced with an accounting program's payroll module?**

3. Multiplexers

- a. Devices to be attached**
- b. Location of these devices**
- c. Type of transmission required**
- d. Speed required**

4. Protocol converters

- a. Devices to be attached
- b. Protocols involved (SNA, BSC, ASCII, etc.)?

5. Power protection required

- a. Voltage regulation
- b. Limits sags, surges
- c. Prevents common-mode noise
- d. Provides battery backup

II. Software

A. Operating system and utility programs

1. DOS

- a. Which version for the root directory?
- b. Are there multiple version on the network?

2. Electronic mail

- a. Menu-driven
- b. Help screens available to users
- c. Display messages
- d. Distribution lists possible
- e. Notification when a message arrives
- f. Ability to forward messages
- g. Ability to define multiple user groups
- h. Ability to print and file messages
- i. Ability to attach files including graphics
- j. Other features desirable

3. Network calendar

- a. All workstations allowed access to calendar features
- b. Ability to schedule rooms and hardware resources.

B. Network Management

- 1. Ability to perform diagnostics**
- 2. Ability to add and delete users groups**
- 3. Password protection**
- 4. Maintain user statistics**
- 5. Ability to handle remote dial-in users**
- 6. Ability to handle multiple operating systems**
- 7. Ability to handle bridges to other networks**
- 8. Ability to add and delete printers easily**
- 9. Security provided**
 - a. Log-in level (password required)**
 - b. Directory level**
 - c. File level**
 - d. File attributes**
- 10. Menu-driven, but allowing sophisticated users to bypass the menu and use commands**
- 11. Log-in scripts or other facilities (such as batch files)**
- 12. Printer server software**
 - a. Number of printers permitted on the network**
 - b. Number of share devices**
 - c. Printer queues**
 - i. Size**
 - ii. Ability to change printing priority**

d. Commands available to network users

- i. For setting parameters for specific printing jobs**
- ii. For disabling printer for routine servicing**

e. Print spooling software

f. Types of printers supported

- i. Parallel**
- ii. Serial**
- iii. Laser**
- iv. Line printers**

13. File server software

- a. Size of volumes permitted**
- b. Access speed**
- c. network drives (logical drives) permitted**
- d. Virtual drives (transparent to users)**
- e. Restore tape to disk capability**
- f. Directory hashing**

14. Network communications server software

a. Protocols supported

- i. ASCII asynchronous**
- ii. 3270 BSC**
- iii. 3270 SNA**
- iv. X.25**

b. Speed supported

- c. Ability to handle call-back modems**
- d. Automatic dial-out**
- e. User statistic provided**

C. Current software that the network must support

1. Word processing
2. Spreadsheets
3. Database management
4. Accounting
5. Other application software

SOFTWARE LICENSES

D. New application software required

1. Word processing
 - a. Compatibility with current software
 - b. Features required
 - c. Training to be provided
2. Spreadsheet/financial analysis
 - a. Compatibility with current software
 - b. Features required
 - c. Training to be provided
3. Database management
 - a. Compatibility with current software
 - b. Features required
 - c. Training to be provided
4. Accounting
 - a. Compatibility with current software
 - b. Features required
 - c. Training to be provided

5. Custom software required

- a. Compatibility with current software
- b. Features required
- c. Training to be provided

III. Vendor Requirements

A. Experience

- 1. Company history: how long at present location
- 2. Customer references for similar installation?

B. Service

- 1. Number of factory-trained service technicians
- 2. Ability to provide on-site service:
 - a. Repair-or-replace service within 24 hours?
 - b. Responds 24 hours a day?
 - c. Ability to respond within two hours?
 - d. Maintains a sufficient inventory or parts to provide adequate service?

C. Ability to provide a LAN demonstration

- 1. Software to be identical with ordered software
- 2. Hardware to be identical with ordered hardware
- 3. Benchmark test to be conducted

D. Training

- 1. Can the supplier provide basic user training?
- 2. Can the supplier provide training on all purchased software?

3. How much training is provided with installation?
4. What is the charge for additional training?
5. Is phone support included in purchase price?
6. What kind of training does the network administrator receive? How many people may take this training?

E. If multiple vendors are required for this network, who will assume responsibility for:

1. Hardware training and network familiarization?
2. Hardware service?
3. Software training?
4. Software service?

APPENDIX B

911XX0006

Engineering Design Support Document (EDSD)

Summary

*(This item will be filled in last by the technical writer and will come from the Abstract;
these will be key words which best summarize the problem and solution addressed on this form)*

DOCUMENT SIGNOFF

Signature

Date

Request Made By:
(Technical Manager)

Request Approved By:
(Engineering Design Manager)

Request Accepted By:
(Network Prototype Manager)

Final Acceptance:
(Network Prototype Manager)

Final Acceptance:
(Engineering Design Manager)

Final Acceptance:
Louis Zaytoun
(Division Chief, Systems Integration)

11-11-91 3006
FEI

ASD/SCN WAVELAN TEST AND EVALUATION

SUBMITTED TO:

DEPARTMENT OF THE AIR FORCE
AERONAUTICAL SYSTEMS DIVISION
COMMUNICATIONS/ELECTRONICS DIRECTORATE (ASD/SCN)
WRIGHT-PATTERSON AIR FORCE BASE, OHIO 45433

SUBMITTED BY:

FRONTIER ENGINEERING, INC.
5100 SPRINGFIELD PIKE
SUITE 401
DAYTON, OHIO 45431

PREPARED BY:

SANDY ALLEN

DATE: 19 DECEMBER 1991

CONTRACT NO. F33657-87-D-0097-0037
TASK ORDER 87-36
CDRL NUMBER 0004
FEI NUMBER 3.3.3.5-36-0004-10

FEI

APPROVALS

PREPARED BY: Sa L. Allen Systems Analyst 12-23-91
NAME TITLE DATE

APPROVED BY: Barbara J. Morro Project Engineer 12-30-91
NAME TITLE DATE

APPROVED BY: C. E. Wilson Program Mgr. 12/30/91
NAME TITLE DATE

**FRONTIER ENGINEERING, INC.
5100 SPRINGFIELD PIKE
SUITE 401
DAYTON, OHIO 45431**

**CONTRACT NO. F 33657-87-D-0097-0037
TASK ORDER 87-36
CDRL NUMBER 0004
FEI NUMBER 3.3.3.5-36-0004-10**

WAVELAN TEST AND EVALUATION

TABLE OF CONTENTS

SECTION	SUBJECT	PAGE
1.0	GENERAL	1-1
1.1	Introduction	1-1
1.2	NCR WAVELAN Card	1-1
1.3	Persoft Intersect Concentrator	1-2
2.0	WAVELAN ARCHITECTURE	2-1
2.1	Wired Ethernet Configuration	2-1
2.2	Intersect Concentrator Configuration	2-1
2.3	Workstation Configuration	2-1
2.3.1	Protocol Stack	2-2
3.0	PRODUCT EVALUATION	3-1
3.1	NCR WAVELAN Overview	3-1
3.2	Persoft Intersect Concentrator Overview	3-1
3.3	Installation	3-1
3.3.1	Persoft Intersect Concentrator Bridge	3-2
3.3.2	WAVELAN Workstations	3-2
3.3.3	Memory Management	3-2
3.4	Coverage Area	3-3
3.4.1	Received Signal Level	3-3
3.4.2	Point-to-Point Tests	3-4
3.5	Application Load Tests	3-4
3.5.1	Time-to-Load Tests	3-4
3.5.2	Incremental Loading Test	3-4
3.6	Bridge Tests	3-5
3.6.1	Time-to-Load Tests	3-5
3.7	WAVELAN Difficulties	3-5
3.8	Network-Related Installation Difficulties	3-5
3.9	Other Installation Considerations	3-6
3.10	SMARTERM 340	3-6

WAVELAN TEST AND EVALUATION

TABLE OF CONTENTS (cont'd.)

<u>SECTION</u>	<u>SUBJECT</u>	<u>PAGE</u>
4.0	CONCLUSIONS	4-1
4.1	Installation	4-1
4.2	Memory Management	4-1
4.3	Coverage Area	4-1
4.4	Application Load Time	4-1
4.5	User Acceptance	4-1

LIST OF APPENDICES

APPENDIX A	Basic Network Software Load and Configurations	A-1
APPENDIX B	Desktop III Configuration	B-1
APPENDIX C	Z-248 Configuration with RYBS Card	C-1
APPENDIX D	Z-248 Configuration without RYBS Card	D-1

WAVELAN TEST AND EVALUATION

LIST OF FIGURES

FIGURE		PAGE
Figure 1.	Network Configuration	2-1
Figure 2.	Protocol Stack	2-2

LIST OF TABLES

TABLE		PAGE
Table 1.	Available Memory	3-3
Table 2.	Average Time to Load Excel	3-4

1.0 GENERAL

1.1 INTRODUCTION

The ASD/SC Network Integration Team evaluated NCR's WaveLAN wireless network interface card (NIC) in Building 676, Wright-Patterson Air Force Base, OH. The evaluation was conducted between September and November, 1991.

The wireless LAN technology was looked at as an alternative to the high cost of designing, installing, and maintaining a cable plant in any size organization. The wireless LAN would also be beneficial in a situation where building construction, office layout, or lease agreements preclude installing a wired network. Wireless LANs lend themselves to providing networked workstations that can be easily relocated, easily installed, and easily maintained.

The evaluation was conducted to determine the performance of NCR's WaveLAN network interface card and Persoft's Intersect Concentrator in a typical ASD network environment. Items of concern were ease of installation, memory requirements, expected coverage area, time-to-load applications, and user acceptance. Tests were performed on Z-248s, Desktop IIIs, and several other 80386-based microcomputers. Over the course of testing, 17 users were connected via the WaveLAN to the wired Ethernet in ASD/SC.

The Network Integration Team consisted of the following people:

Team Manager: Captain James Geier, USAF

Team Members: Sandy Allen, Frontier Engineering, Inc.
Elaine Townsend, TRW

1.2 NCR WAVELAN CARD

The NCR WaveLAN NIC is a full-length, 16-bit ISA card with an external omni-directional antenna module with a five-foot coaxial cable. The WaveLAN card's range with the omni-directional antenna is dependent on a variety of environmental factors. The WaveLAN NIC can also work with a wide range of operating systems and networks. The specifics are listed below:

NETWORK INTERFACE CARD	
Data Rate	2 Mbit/sec
LAN Diameter	100 feet (closed office) 200 feet (typical) 800 feet (open office)
Protocol	CSMA/CA (Ethernet variety)
Transmission	Spread Spectrum, DQPSK keying, 902 Mhz to 928 Mhz
Output Power	250 Mw
Security	Optional NBS/DES (data encryption standard)
INTERFACES	
OS	DOS, OS/2, UNIX
DRIVERS	IPX, NDIS, ODI, DLPI
Network OS	Novell, LAN Manager, TCP/IP, Banyan VINES
Coupling	Ethernet, Token Ring

1.3 **PERSOFT INTERSECT CONCENTRATOR**

Persoft's Intersect Concentrator was used to bridge the wireless WaveLAN to the wired ethernet. The concentrator package included a pre-configured 16-bit Western Digital NIC and self-installing software, which can be run from a self-booting floppy or hard disk. The Concentrator operates at the data link layer of the Open Systems Interconnection (OSI) model which allows it to operate with Novell NetWare, Banyan VINES, TCP/IP, or any other network compatible with the NCR WaveLAN. The Concentrator provides address filtering which only allows traffic destined for WaveLAN workstations through. Other features include loop detection, access control, protocol and address filtering, and optional DES encryption.

2.0 WAVELAN ARCHITECTURE

2.1 WIRED ETHERNET CONFIGURATION

The Ethernet network consisted of two AT&T 3B2 file servers, a VAX, and DEC Server located in ASD/SC, Building 676. The software used was FTP, Inc.'s PC/TCP with NETBIOS and 10NET. Persoft's Intersect Concentrator was used to bridge the WaveLAN to the wired Ethernet. Figure 2 shows the basic LAN configuration.

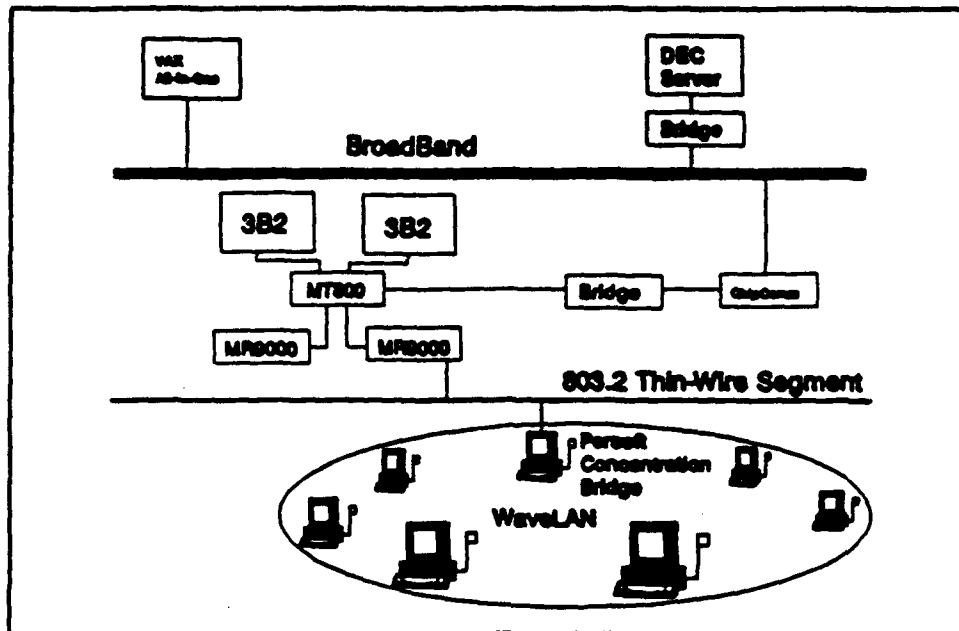

Figure 1. Network configuration

2.2 INTERSECT CONCENTRATOR CONFIGURATION

Persoft's Intersect Concentrator was used to bridge the WaveLAN to the wired Ethernet. The Concentrator was comprised of a Western Digital and WaveLAN card installed in a Z-248. The Intersect Concentrator software was loaded from a self-booting floppy disk. The software allowed for configuration of the Network ID, address and protocol filtering, DES encryption, and spanning tree.

2.3 WORKSTATION CONFIGURATION

Client workstations consisted of variety Z-248 computers with anywhere from 512 kbytes to 2.5 Mbytes of expanded memory. Several of the Z-248s were configured with RYBS Advanced Memory Specification cards. Unisys Desktop IIIs, NEC 386/25, and DTK, 80386 microcomputers with 4 Mbytes of RAM were also used. The 386 computers were configured with QEMM 5.1 as a memory manager.

2.3.1 PROTOCOL STACK

The network software included three NDIS device drivers which were loaded from the CONFIG.SYS file, and NETBIND bound the device drivers to FTP's generic ETHDRV driver. NETBIOS and 10Net were then loaded. The protocol stack is detailed in Figure 3. Complete file listings are in the appendices.

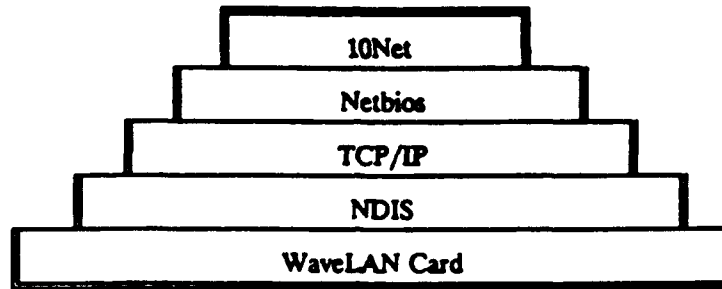

Figure 2. Protocol Stack

3.0 PRODUCT EVALUATION

3.1 NCR WAVELAN OVERVIEW

The manuals supplied with the WaveLAN cards we received only explained how to set up the systems in a Novell environment using IPX. No literature was supplied for setting up the WaveLAN in any other environment. The basic NDIS configuration had been worked out during preliminary testing with the assistance of NCR and Persoft.

Included with the WaveLAN package is a point-to-point software utility that provides an indication of the received signal level (RSL) and signal-to-noise ratio (SNR). The test was run between each workstation and a test workstation adjacent to the concentrator bridge. The received signal level was used to align the antennas and the SNR was used to determine the expected performance at that particular location.

NCR also included a node diagnostic utility, TALLIES, which displays the values of a workstations diagnostic counters. By periodically collecting the counter values, you can build a profile of network capability. Unfortunately, this program only runs in the Novell environment and could not be used to assess the WaveLAN performance in a PC/TCP environment.

3.2 PERSOFT INTERSECT CONCENTRATOR OVERVIEW

The manual for the Concentrator was very detailed in setting up the bridge and overall network operation. The software provides a visual display of the activity on both the WaveLAN and wired sides of the bridge. This builds some level of confidence when first setting up the system or when problems are reported.

3.3 INSTALLATION

Once several initial wired Ethernet problems were overcome (Para 3.8), installation of the WaveLAN and necessary software went smoothly. A network administrator with a good DOS and technical background is needed to set up the initial configurations and make up network install disks. A new deployment with installation procedures could be handled by less qualified personnel.

The first step was to incorporate the device drivers and network software into the ASD/SC standard network and memory configurations. This included optimizing memory usage and setting up configurations for three different workstations. Once these were tested, the number of users was expanded to 17. The users were selected at random from those not having access to the network and those having connectivity to ASD/SC's Ethernet. All users were provided logs to document any problems they encountered.

3.3.1 PERSOFT INTERSECT CONCENTRATOR BRIDGE

The Western Digital card was configured to use thin Ethernet; no other adjustments were required. The Western Digital card and a WaveLAN card were installed in empty 16 bit slots in a Z-248 computer. The WaveLAN card switches were left at the factory default Base Address of 300h, and WaveLAN's INSTCONF.EXE program was run to set the IRQ to 10 and Network ID to 01-00.

Intersect Concentrator's INSTALL program was used to install the Concentrator on a self-booting 5 1/4 inch floppy diskette. The concentrator was configured for a Network ID of 01-00, no address or protocol filtering, no encryption, and the spanning tree was disabled.

The computer was booted and the Concentrator bridge loaded automatically.

3.3.2 WAVELAN WORKSTATIONS

The ASD/SC network install disks were used to load the latest versions of the PC/TCP, 10NET, and RYBS or QEMM software. The install disks configured the various files for use with a Western Digital NIC. The six files listed required minor modification to load various drivers for the WaveLAN NIC. Configurations for the various computers are in the appendices.

CONFIG.SYS
AUTOEXEC.BAT
LOADNET.BAT (386s only)
LOGIN.BAT
IFCUST.SYS
WORK.PRO

The existing install batch files could easily be modified to accommodate a large WaveLAN implementation.

3.3.3 MEMORY MANAGEMENT

The amount of memory available for DOS applications is very important. Applications such as Harvard Graphics and Air Force Forms require between 485 and 520 kbytes to run and/or print. Various memory management tools were used on the different platforms.

3.3.3.1 Z-248 Computers

A RYBS Advanced Memory Specification card was installed in a test Z-248 and various configurations were tested in order to determine the best use of memory. The three NDIS device drivers, PROTMAN.DOS, DNCRWL02.DOS, and DISPKTPM.DOS would not work in high memory. Persoft was contacted and they recommended the drivers be loaded in conventional memory. Persoft indicated that if the drivers were loaded high, the computer would slow down because of the amount of paging required to handle the network traffic. The other network files, IFCUST.SYS, IPCUST.SYS, ETHDRV.EXE, and NETBIOS.EXE

3.4.2 POINT-TO-POINT TESTS

Point-to-point tests were conducted between the first and the second floors. Tests were conducted from the Network Management and Control Center and from the Novell Test Bed on the computer room floor. The approximate distance was about 105 feet. The RSL registered about 1.5 with a SNR of 3 for each location. We were able to login to the network after a long delay at these locations.

Several spot checks were made from the second floor closer to the concentrator bridge and, as expected, the RSL and SNR increased to more acceptable readings of 2.5 to 3.0 and 4 respectively.

3.5 APPLICATION LOAD TESTS

3.5.1 TIME-TO-LOAD TESTS

Time-to-load tests were conducted during low traffic periods using two Desktop III 386 computers. One used the WaveLAN, and the other connected to the wired Ethernet. Excel and Word for Windows were loaded from the server ten times on several occasions and the load times were averaged. Loading an application from the server via the WaveLAN took an average of seven seconds longer than that of the wired computer.

3.5.2 INCREMENTAL LOADING TEST

An incremental loading test was conducted to determine any delays caused by increasing number of users on the WaveLAN network. There was no attempt to isolate the delay caused by the file servers, the other network software such as Netbios, or the WaveLAN itself. This test was just to provide the amount of delay a user might encounter.

Because of time constraints, consistency, and configuration control, the load times of the Desktop III, used in previous tests, were used. Excel was loaded ten times and averaged. The same test was then run with two, four, and six Desktop IIIs.

Table 2 shows the average load times for the test. A 62 percent increase in load time was realized from one to six workstations.

Number of Computers	Time to Load (in seconds)
1	22.5
2	27.0
4	30.0
6	35.8

Table 2. Average Time to Load Excel

were all loaded high. The 10NET's data segment could not be loaded high because of memory conflicts that caused the computer to lock up.

3.3.3.2 386-Based Computers

A Desktop III was configured with QEMM 5.1 memory manager and the network software was loaded essentially the same as the software load used with the Western Digital NIC. IFCUST.SYS, IPCUST.SYS, ETHDRV.EXE, and NETBIOS.EXE were all loaded high. 10NET64's data segment was also loaded high. This configuration also worked on a NEC/25 and DTK.

3.3.3.3 Memory Availability

QEMM's Manifest (MFT) was used to measure the available memory after loading only the necessary network software. Device drivers such as SMARTDRIVE and SHARE were not loaded. Table 1 lists the amount of memory available in the various workstation configurations. The TRW NIC is a smart card; therefore, its driver was loaded in its memory and not in the computer's memory.

Workstation	WaveLAN	Western Digital	TRW Smart Card
Desktop III	501k	530k	N/A
Z-248 with RYBS	448k	N/A	565k
Z-248	374k	N/A	446k

Table 1. Available Memory

3.4 COVERAGE AREA

Building 676 is two-story building constructed of steel-reinforced concrete. The first floor is primarily office space. The main hallways are cinder block, while office walls are metal-supported sheet rock. Most offices are large rooms with cubicles made up of shoulder-height modular furniture. The second floor consists of a large computer room with numerous mainframe computers on a raised metal floor. Irregular shaped office space is located across the front of the building. This construction is less desirable than NCR's description of a closed office.

3.4.1 RECEIVED SIGNAL LEVEL

Each client location was tested with the point-to-point diagnostics and the antennas were adjusted for best received signal level (RSL) with the antenna about 6 feet high. The lowest RSL for a client workstation was approximately 2.5 on a scale of 5, and the signal-to-noise ratio (SNR) was 4 on a scale of 5. Four of the workstations were located approximately 100 feet from the bridge, with the longest link at 120 feet.

3.6 BRIDGE TESTS

3.6.1 TIME-TO-LOAD TESTS

The Z-248 bridge was replaced by a NEC 386/25. Time-to-load tests were once again conducted using two Desktop III computers, one on the WaveLAN the other connected to the wired Ethernet. The same test of loading Excel and Word for Windows was conducted on both Desktop III computers. The time to load the applications remained, on average, the same as with the Z-248 concentrator bridge.

According to Persoft, the 8 Mhz, Z-248 computer is more than adequate for most network environments. A 386 would benefit the WaveLAN when the wired Ethernet has heavy traffic. The increased processing speed would enable the Concentrator to capture and process packets faster and lower re-transmissions on the wired Ethernet.

3.7 WAVELAN DIFFICULTIES

Two users experienced minor problems while using AMS. They would get characters scattered on the screen display or incomplete menus. The screen display could be refreshed by pressing <CTRL-W>. Further investigation revealed that they were using CALL and KERMIT through Comm Port 2 to connect to a DEC Server instead of using the WaveLAN network. The cause of the problem was not resolved. It is believed to be a conflict with the device drivers and the communications port.

3.8 NETWORK-RELATED INSTALLATION DIFFICULTIES

Problems occurred when setting up the third workstation with a WaveLAN card from a new shipment. The Z-248 was able to access the network, but was not recognized by the 3B2 file servers. Numerous tests on three new WaveLAN cards were conducted along with software configurations. The team worked with NCR, Persoft, Network Monitoring and Control Center (NMCC), and 3B2 administrators. A Sniffer was also used to check the broadcasts on the wired Ethernet. All tests indicated the card and software were working properly. The computer was able to ping other WaveLAN computers and could access 10NET configured super computers. However, the computer could not ping, and therefore not mount, the 3B2 servers.

We received conflicting analysis of the problem from both NMCC and the administrators. The evidence pointed to a wiring or cabling problem, but we were told that the cable segment went straight to the 3B2. The only thing not tried up to this point was moving the Concentrator to the newly installed cable segment. Once the Concentrator was connected to the new segment, the new cards readily accessed the 3B2 servers.

Further investigation revealed that the Concentrator had been connected to the older development segment of the Ethernet. This previous development segment had at least three other bridges and a Chipcomm modem in the path to the 3B2 servers. Apparently an access table in one or more of the bridges was full and not allowing any new Ethernet addresses through.

During preliminary testing several months earlier, a similar problem was encountered. This problem was solved after other wired Ethernet problems were corrected. The assumption is that the bridges were all reset at that time, and the original WaveLAN card's addresses were already in the bridge's access tables when this testing began.

3.9 OTHER INSTALLATION CONSIDERATIONS

As with any new network, several factors need to be considered. This is especially true if Z-248s and Windows 3.0 are to be used with applications located on the file server.

1. Z-248 Memory: Recommend using DOS 3.3+, 2.5 Mbytes expanded, and a RYBS Advanced Memory Specification card.
2. Access to AMS: Some production users may need to be configured differently. Possible use of Persoft's ST340 configured to use LAT to avoid TCP/IP and Netbios delays.
3. User Training: Changes in the overall operating environment:
 - Change from using CALL 2.4 to KERMIT
 - Windows application training

3.10 SMARTERM 340

To try and improve performance with the VAX and AMS, Persoft's SMARTERM 340 (ST340) was tested as a terminal emulator. ST340 was installed on a test Z-248 and configured to use LAT. The DISPKTPM.DOS driver had to be replaced by Persoft's PKTDRV.DOS driver in the CONFIG.SYS file. The Z-248 was configured to load only the NDIS drivers, and the GOLAT.BAT file was used to run ST340.

Initial testing with AMS indicated noticeable increase in the responsiveness of the Z-248 workstation versus using TNGLOSS and KERMIT. A full-time AMS user then tested ST340 for a day. The user said AMS's speed was comparable to TNVT run from a window in Windows 3.0 on a Desktop III. The user experienced problems with slow screen response, and having to refresh the screen after activities like cut and paste. The inability to map <Pg Up> and <Pg Dn> keys, and use the 80/132 column mode were also noted.

ST340 may be useful in speeding up overall performance with the VAX. The occasional slow screen response may be attributed to a busy WaveLAN, but other factors clearly indicate other problems not acceptable to most users.

4.0 CONCLUSIONS

4.1 INSTALLATION

The most difficult part of an installation is starting from scratch with the network software load. The WaveLAN manuals at this time do not discuss anything other than a Novell 286 environment. With the information and configurations presented in this document, a WaveLAN setup is no more difficult than installing a Western Digital or TRW Ethernet card.

4.2 MEMORY MANAGEMENT

The WaveLAN memory configuration used about 30kbytes more than the Western Digital configuration on the 386 machines. This is attributed to the device drivers being loaded in conventional memory. There were much greater differences with the Z-248s with and without the RYBS card and the TRW smart card. The TRW smart card allows the Ethernet driver to be loaded on the card. The 10NET data segment can be loaded high. With the WaveLAN card configuration, the 10NET data segment could not be loaded high because of a memory conflict that caused the computer to lock up. In a Windows-based environment, these differences would not be of much concern.

4.3 COVERAGE AREA

In a closed office environment such as Building 676, a 100 foot radius was about the farthest we could expect without degrading response time. In planning and designing a wireless installation, the point-to-point utilities can be used to determine the ideal location for the bridge and the expected coverage area. We recommend that the minimum RSL be no lower than 2.5 with a SNR of 4.

4.4 APPLICATION LOAD TIME

On a Desktop III, Excel and Word for Windows load times averaged 7 seconds longer on the WaveLAN versus the wired Ethernet. The times were significantly longer on the Z-248, because of the Z-248s slower CPU speed. The delay increase was in the 60 to 70 percent range, but the overall time increase was not considered significant.

4.5 USER ACCEPTANCE

Many of the users were satisfied with the WaveLAN connectivity. A majority of the complaints received had nothing to do with the WaveLAN itself. This being a test environment, users quickly reported any and all network problems they encountered. Most of the problems were associated with the file servers or application software and not the WaveLAN. The users who used AMS via a DEC Server were the most displeased, because their overall performance had decreased.

To attempt improving performance with the VAX and AMS, Persoft's SMARTERM 340 was tested using LAT over the WaveLAN. The user said AMS's speed was comparable to

TNVT run in a Window in Windows 3.0 on a Desktop III. The user did experience problems with sluggish screen response, screen updates, key mapping, and using the 80/132 column mode.

APPENDIX A

BASIC NETWORK SOFTWARE LOAD AND CONFIGURATIONS

BASIC NETWORK SOFTWARE LOAD AND CONFIGURATIONS

CONFIG.SYS

device = c:\ncrowave\protman.dos /i:\ncrowave
device = c:\ncrowave\dncrwl02.dos
device = c:\ncrowave\dispktpm.dos
device = c:\ncrowave\ifcust.sys
device = c:\ncrowave\ipcust.sys

AUTOEXEC.BAT

PATH C:\;C:\DOS;C:\NCRWAVE;C:\PCTCP;C:\10NET;
c:\ncrowave\netbind
c:\ncrowave\ethdrv.exe -t 8 -u 4 -p 8
c:\pctcp\netbios -s ""
c:\10net\10net64 c:\10net\work.pro

IFCUST.SYS

FTP Software PC/TCP ifconfig Version 2.03
Copyright (c) 1986,1988 by FTP Software, Inc.
interface is PC/TCP Generic non-hardware-dependent driver (type 2561)
interface number 0
IP address: 129.48.7.103
6 bits of subnet (subnet); mask is 255.255.252.0
no flags set

IPCUST.SYS

FTP Software PC/TCP ipconfig Version 2.03
Copyright (c) 1986,1988 by FTP Software, Inc.
Host (hostname.domain): pc103spc.wpafb.af.mil
Short username (userid): WAVELAN
Long username (fullname): (not set)
Office (office): 155
Phone (phone): (not set)
Timezone name (tzname): 0, offset 300
Default gateway (gw): 129.48.7.252
TCP default window (window): 4096 low window (lowwindow): 512
Host table (hosttable): c:\pctcp\hosts.txt
Mail relay host (mailrelay): SCNO
name servers (ns): none configured
domain name servers (ds): 129.48.23.254 129.48.23.253

time servers (ts): none configured
log: 129.4.16.70 cookie: 129.4.16.70
lpr: 129.4.16.70 iprint: 129.4.16.70
terminal emulation: will not wrap long lines; will send backspace for <- key
Default precedence: Routine, lax matching
debugging flags (debug): all off

WORK.PRO

NODE = P7103SCP
USER = WAVELAN
HMAXMS = Y
CERR = N
BUFFERS = 5
BUFFSIZE = 3
SBUFFERS = 8
MOUNTS = 16
OPENFCB = 20
FCBKEEP = Y
OPENHNDL = 20
AUTOSP = 20
CHATTIME = 0
SHOWMEM = Y
DTIMEOUT = 2
DATAGRM = 2
DGRETRY = 3
NCB_LSN = 16
NCB_NUM = 16

[protocol manager]
 Drivername = protman\$

```
-----  
;- PACKET DRIVER INTERFACE  
-----  
; Bracketed module name must be [PKTDRV]  
;  
; "DRIVERNAME" must be PKTDRVS  
;  
; "BINDINGS" must be the MAC module name in brackets  
;  
; "INTVEC" is the interrupt vector in the range 0x60 to 0x80  
-----
```

[PKTDRV]

DRIVERNAME = PKTDRVS
BINDINGS = NCR
INTVEC = 0x65

; Protocol.ini entry for NCR WaveLAN AT Communications Adapter.

[NCR]

DRIVERNAME = NCRWVES
IOBASE = 0x300
ACR = 6
NETWORKID = 256

APPENDIX B
DESKTOP III CONFIGURATION

DESKTOP III CONFIGURATION WITH QEMM

CONFIG.SYS

```
device = c:\qemm\qemm386.sys db=8 noems ram = b000-b7ff x = c800-cdff ram = ce00-ffff
device = c:\ncrwave\protman.dos /i:\ncrwave
device = c:\ncrwave\dncrw102.dos
device = c:\ncrwave\dispktpm.dos
device = c:\qemm\loadhi.sys /r:1 c:\ncrwave\ifcust.sys
device = c:\qemm\loadhi.sys /r:1 c:\ncrwave\ipcust.sys
Break = on
shell = c:\dos\command.com /p /e:1024
buffers = 20
files = 30
stacks = 0,0
lastdrive = n
```

AUTOEXEC.BAT

```
@echo off
REM .....
REM ASD/SC Autoexec.bat file
REM Version 4.0 DT3
REM MAY 91
REM .....
PATH c:\;c:\qemm;c:\dos;c:\ncrwave;c:\pctcp;c:\10net;c:\windows;
c:\ncrwave\netbind
prompt $p$g
set comspec=c:\dos\command.com
call loadnet.bat
```

LOADNET.BAT

```
REM .....
REM ASD/SC Network Server Login Process MAY 91
REM FILENAME: loadnet.bat
REM VERSION: 4.0 DT3
REM .....
SET _UN=WAVELAN
SET _IP=129.48.7.103
SET _SN=P7103SCP
SET _OS=pctcp
SET _HS=SCPC
SET _FTP_ATTR=31,30,78
SET _VT220_KEYMAP=C:\PCTCP\VT220AMS.MAP
SET _TEMP=C:\WINDOWS\TEMP
C:\qemm\loadhi /r:2 C:\ncrwave\ethdrv.exe -t 8 -u 4 -p 8
```

```

Echo .
Echo Username: % UN%
Echo IP Address: % IP%
Echo System Name: %_SN%
Echo .
what c "DO YOU WANT NETWORK DRIVES AND PRINTERS? (y/n)" ynYN
if %what% = =n goto end
if %what% = =N goto end
call c:\ncrwave\login.bat
:end

```

LOGIN.BAT

```

@echo off
REM .....
REM BEGIN "LOGIN.BAT"
REM .....
REM ASD/SC NETWORK Server Login Process MAY 91
REM FILENAME: login.bat
REM VERSION: 4.0 DT3
REM .....
c:\pctcp\discon.exe > nul
c:\qemm\loadhi /r:2 c:\pctcp\netbios -s "" > nul
c:\10net\10net64 c:\10net\work.pro > nul
c:\pctcp\register c:\pctcp\net
if exist j:\netpath.bat goto net up
echo .....
echo Login Failed!! You are NOT connected to the server!
echo .....
goto done
:net up
call j:\netpath
Echo ***** Network Resources *****
use
:done
pause
REM .....
REM END "LOGIN.BAT"
REM .....

```

APPENDIX C

Z-248 CONFIGURATION WITH RYBS CARD

Z-248 CONFIGURATION WITH RYBS CARD

CONFIG.SYS

```
device = c:\osc\himem.sys
device = C:\ams\hi2plus.sys
device = \ncrowave\protman.dos /i:\ncrowave
device = \ncrowave\dncrw102.dos
device = \ncrowave\dispktpm.dos
shell = c:\command.com /e:1500 /p
Break = on
```

AUTOEXEC.BAT

```
REM .....
REM ASD/SC Autoexec.bat file
REM SEPT 91 WAVELAN
SET _UN=DEMO
SET _IP=129.48.7.102
SET _SN=PC102SCN
SET _OS=OSC
SET _HS=SCNO
REM .....
PATH C:\;C:\DOS;C:\WINDOWS;C:\OSC;C:\10NET;C:\AMS;
ECHO OFF
c:\ncrowave\netbind
REM Initialize RYBS memory
\ams\xmem b000 b800
device /h c:\ncrowave\ifcust.sys
device /h c:\ncrowave\ipcust.sys
device /h c:\dos\ansi.sys
files /h 40
lastdriv /h z
buffers /h 20
\ams\loadhigh c:\mouse.com
PROMPT $p$g
cd \osc
call login.bat
\ams\cutmc -s
if % net% = =down goto no_net
if % _net% = =up goto net_up
goto done
:net_up
echo The network is UP!!
goto done
:no_net
```

```
echo The network is DOWN!!
:done
REM End of network related calls
```

LOGIN.BAT

```
REM .....
REM ASD/SC NETWORK Login Process 04/20/90
REM FILENAME: login.bat WAVELAN
REM VERSION: 1.0
REM DOS version 3.3
REM .....
echo off
YN WOULD YOU LIKE TO USE THE NETWORK? (y/n)
if errorlevel 1 goto nonet
echo YES
echo .
Echo %_UN%
Echo IP Address %_IP%
Echo System Name %_SN%
c:\ncrwave\ethdrv.exe -t 8 -u 4 -p 8
if errorlevel 1 goto nonet
SET _IP=
SET _SN=
SET _OS=
SET _HS=
cd \osc
\ams\xmem c800 d0c0
\ams\loadhigh netbios.exe -s ""
cd \10net
10wk.exe c:\10net\work.pro
CD \
if errorlevel 1 goto nonet
cd\osc
register c:\osc\net
cd\
if errorlevel 1 goto nonet
call j:\netpath
if errorlevel 1 goto nonet
set _net=up
goto end
:nonet
echo NO
echo .
```

```
set_net = down  
:end  
c:  
cd \
```

APPENDIX D

Z-248 CONFIGURATION WITHOUT RYBS CARD

Z-248 CONFIGURATION WITHOUT RYBS CARD

CONFIG.SYS

```
device = C:\himem.sys
device = \ncrowave\protman.dos /i:\ncrowave
device = \ncrowave\dncrw102.dos
device = \ncrowave\dispktpm.dos
device = c:\ncrowave\ifcust.sys
device = c:\osc\ipcust.sys
shell = c:\command.com /p /e:1024
files = 40
buffers = 20
lastdrive = z
```

AUTOEXEC.BAT

```
REM .....
REM ASD/SC Autoexec.bat file
REM Version 2.0 EGA WaveLAN Sept 91
SET _UN=DEMO
SET _IP=129.48.7.127
SET _SN=PC127SCP
SET _OS=OSC
SET _HS=
SET _TEMP=C:\WINDOWS\TEMP
REM .....
PATH C:;\C:\DOS;C:\WINDOWS;C:\OSC;C:\10NET;C:\AMS;
c:\ncrowave\netbind
Echo Off
PROMPT $p$g
call login.bat
if %_net% = down goto no_net
if %_net% = up goto net_up
goto done
:net_up
echo You are logged on to the network.
goto done
:no_net
echo You are NOT logged on to the network.
:done
```

LOGIN.BAT

```
REM .....
REM ASD/SC WaveLAN Login Process SEPT 91
REM FILENAME: login.bat
REM VERSION: 1.01
REM DOS version 3.3
REM .....
echo off
YN WOULD YOU LIKE TO USE THE NETWORK? (y/n)
if errorlevel 1 goto nonet
echo YES
echo .
Echo Username: % UN%
Echo IP Address: % IP%
Echo System Name: % SN%
c:\ncrwave\ethdrv.exe -t 8 -u 4 -p 8
if errorlevel 1 goto nonet
SET IP=
SET SN=
SET OS=
SET HS=
cd \osc
netbios.exe -s ""
cd \10net
10wk.exe c:\10net\work.pro
if errorlevel 1 goto nonet
cd \osc
register c:\osc\net
cd\
if errorlevel 1 goto nonet
call j:\netpath
if errorlevel 1 goto nonet
set _net=up
goto end
:nonet
echo You have NOT logged on to the network.
echo .
set _net=down
:end
c:
cd \
```

APPENDIX C

PROJECT 802 - LOCAL & METROPOLITAN AREA NETWORKS

**IEEE P802.11 Draft Standard
Wireless LAN Medium Access Control (MAC)
and
Physical Layer (PHY) Specifications**

Prepared by:
The Editors of IEEE 802.11

This is an unapproved draft which is subject to change and cannot be presumed to reflect the position of Project 802 or the Institute of Electrical and Electronics Engineers

DO NOT SPECIFY OR CLAIM CONFORMANCE TO THIS DOCUMENT

All rights reserved by the
Institute of Electrical and Electronic Engineers

Abstract: TBD (The abstract will be prepared by IEEE staff.)

Keywords: TBD

Note: This is an internal working document of the IEEE 802.11 Working Group on Wireless Medium Access Control and Physical Layer. As such, it is not a standard and may be changed as a result of further work by IEEE 802.11.

Foreword

(This foreword is not part of the Proposed Standard P802.11, Wireless MAC and PHY)

This standard is part of a family of standards for Local Area Networks (LANs)..... TBD

The following are now or have been voting members of the Wireless Medium Access Control and Physical Layer Working Group (P802.11). Those individuals who have served as editors are indicated by an asterisk next to their name:

Chair's Name, *Chair*

Mmmmmmm Nnnnnnn*
Mnnnnnn Nmnnnnnn
Mnnnnnn Nmnnnnnn

Mmmmmmm Nnnnnnn
Mnnnnnn Nnnnnnn
Mnnnnnn Nmnnnnnn

Mmmmmmm Nnnnnnn*
Mmmmmmm Nnnnnnn
Mndnnnn Nnnnnnn

(Editor's note: This section is based on Doc.:P802.11-92/4 and input from L. Van Der Jagt)

Contents

SECTION

- 1. General**
 - 1.1 Purpose
 - 1.2 Definitions
 - 1.3 Abbreviations
 - 1.4 References
 - 1.5 Conformance Requirements
 - 1.6 Conventions
- 2. General Description**
- 3. MAC Service Definition**
 - 3.1 Overview of MAC Services
 - 3.1.1 General Description of Services Provided
 - 3.1.2 Overview of Interactions
 - 3.1.3 Basic Service and Options
 - 3.2 Detailed Service Specification
 - 3.2.1 MA_UNIT_DATA-Request
 - 3.2.2 MA_UNIT_DATA-Indication
 - 3.2.3 Others TBD
- 4. MAC Protocol Data Unit Structure**
- 5. MAC Sub-layer Functional Description**
 - 5.1 MAC Sub-layer Architecture
 - 5.2 MAC State Machines
- 6. PHY Service Specification**
 - 6.1 Overview of PHY Services
 - 6.1.1 General Description of Service Provided
 - 6.1.2 Overview of Interactions
 - 6.1.3 Basic Service and Options
 - 6.2 Detailed Service Specification
 - 6.2.1 PH_DATA_UNIT-Request
 - 6.2.2 PH_DATA_UNIT-Indication
 - 6.2.3 Others TBD
- 7. PHY Protocol Data Unit Structure**
- 8. PHY Layer Functional Description**
 - 8.1 PHY Layer Architecture
 - 8.2 Exposed DTE-DCE Interface Specification
 - 8.3 PHY Layer State Machines
 - 8.3.1 Medium Independent Sub-layer Functions
 - 8.3.2 Convergence Sub-layer Functions
 - 8.3.2.1 GHz ISM Band DSSS Convergence Sub-layer Function
 - 8.3.2.2 GHz ISM Band FHSS Convergence Sub-layer Function
 - 8.3.2.3 Infrared Convergence Sub-layer Function
 - 8.4 Medium Dependent Sub-layer Functions
 - 8.4.1 GHz ISM Band DSSS Medium Dependent Sub-layer Description
 - 8.4.2 GHz ISM Band FHSS Medium Dependent Sub-layer Description

. 8.4.3 Baseband Infrared Medium Dependent Sub-layer
Description

- 9. Layer Management
 - 9.1 Overview of Layer Management Functions
 - 9.2 MAC Sub-layer Management Interface
 - 9.3 PHY Layer Management Interface
- 10. Medium Definitions
 - 10.1 GHz ISM Band Diffuse Medium Definition
 - 10.1.1 General Purpose Office Environment
 - 10.1.2 Large Geometry Hostile Environment
 - 10.2 GHz ISM Band Directed Medium Definition
 - 10.2.1 General Purpose Office Environment
 - 10.2.2 Large Geometry Hostile Environment
 - 10.3 Directed Infrared Medium Definition
 - 10.4 Diffused Infrared Medium Definition

ANNEXES

- Annex A Normative Annex
- Annex B Informative Annex

APPENDICES

Appendix I Functional Requirements

- I.1 Externally Imposed Requirements
- I.2 General Requirements
- I.3 Data Service Types
- I.4 Coordination Functions
- I.5 MAC/PHY Interface
- I.6 Security

Wireless Medium Access Control and Physical Layer Specification

1. General

1.1 Purpose. TBD

1.2 Definitions.

(Editor's note: Extracted from P802.11-92/57 doc., otherwise indicated in each definition))

access point (AP). Any entity that has station functionality and provides access to the distribution system.

authentication. A higher layer process by which one station convinces other stations of its 'identity'.

basic service area (BSA). The area within which members of a basic service set can communicate.

basic service set (BSS). A set of stations controlled by a single coordination function.

channel. (Editor's note - From work done by the PHY Group in 07/92) - An instance of medium use for the purpose of passing packet data units that can coexist with other instances of medium use.

Example

single channel
1 narrowband channel
DSS with 1 code

n-channel
FDM channels
DSSS with CDMA

coordination function (CF). That logical function which determines when a station operating within a basic service set transmits and received via the wireless medium.

distributed coordination function (DCF). A class of possible coordination functions where the same coordination function logic is active in every station at any given time.

distribution system (DS). A system used to interconnect a set of basic service sets to create an extended service set.

distribution system medium (DSM). The medium used by a distribution system (for basic service set interconnections).

distribution system services (DSS). The set of services provided by the distribution system which enable the MAC to transport MAC service data units between basic service sets within an extended service set.

extended service area (ESA). The area within which members of an extended service set can communicate. An extended service area is larger or equal to a basic service area.

extended service set (ESS). A set of interconnected basic service sets which appear as a single basic service set to the logical link control (LLC).

MAC service data unit (MSDU). The MAC service data unit is information that is delivered as a unit between MAC service access points.

point coordination function (PCF). A class of possible coordination functions where the coordination function logic is active in only one station at any given time.

registration. A process by which a station gets its 'identity' (address signature, certificates, etc.).

sign-on. The process by which one station identifies (and possibly authenticates) itself, and exchanges operational parameters in order to participate in a basic service set.

Station (STA). Any device which contains an 802.11 conformant MAC and PHY interface to the wireless medium.

Wireless Medium (WM). The medium used to implement a wireless LAN.

1.3 Abbreviations

(Editor's note: Extracted from section 1.2)

AP	=	access point
BSA	=	basic service area
BSS	=	basic service set
CF	=	coordination function
DCE	=	data communication equipment
DCF	=	distributed coordination function
DS	=	distribution system
DSM	=	distribution system medium
DSS	=	distribution system services
DTE	=	data terminal equipment
ESA	=	extended service area
ESS	=	extended service set
LLC	=	logical link control
MAC	=	medium access control
MSDU	=	MAC service data unit
PAR	=	project authorization request
PCF	=	point coordination function
PHY	=	physical layer
STA	=	station
WM	=	wireless medium

2. General Description

(Editor's note: Model approved as the 'starting point' for further work - 07/92)

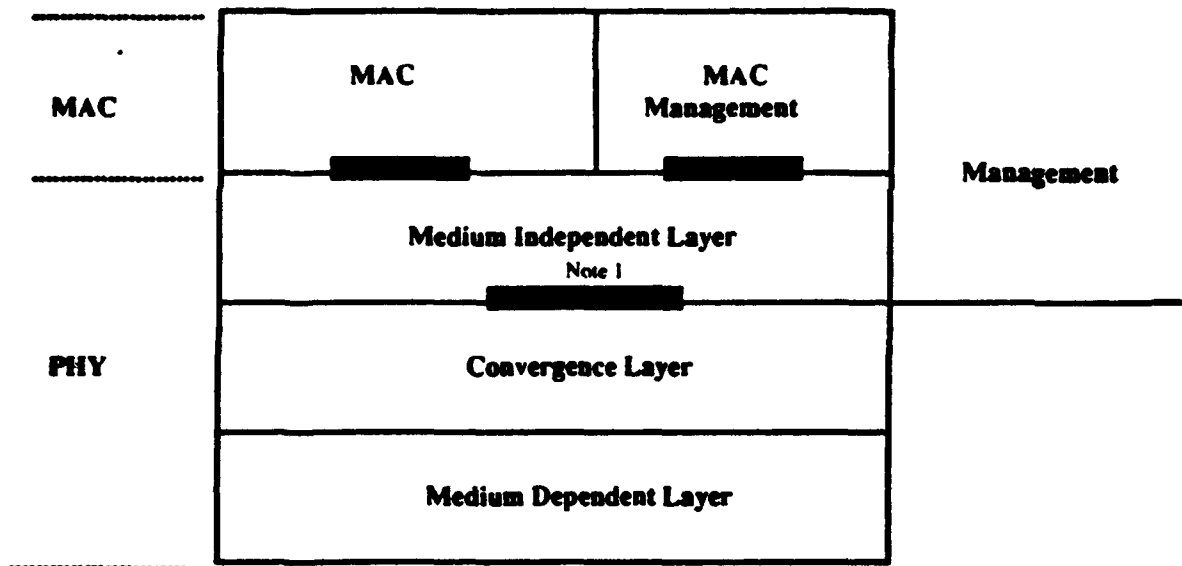

Note 1 - Optional exposed DTE/DCE interface

General Overview of the 802.11 MAC and PHY Layers

8. PHY Layer Functional Description

8.1 PHY Layer Architecture. TBD

8.2 Exposed DTE-DCE Interface Specification. TBD

8.3 PHY Layer State Machines. TBD

8.3.1 Medium Independent Sub-layer Functions.

(Editor's note: From work done by the PHY Group in 07/92)

All PHYs shall support a single channel. Support of additional channel is optional. If more than one channel is implemented a method of informing the MAC about the number of channels, the channel in use and to allow the MAC to change channels will be implemented.

All PHYs shall support a single level of transmit power. Support of additional transmit power levels is optional. If more than one transmit power level is implemented a method of informing the MAC about the number of levels available and the value of these levels and to allow the MAC to modify these levels will be implemented.

All PHYs shall report the status of receive signal strength relative to one threshold. Additional thresholds are optional. If more than one level is supported a method of informing the MAC regarding the number of levels, and the values of these levels will be implemented. The indication of receive power will be delivered on a frame by frame basis.

Appendix - L. Functional Requirements

(Editor's note: this section is extracted from P802.11-92/57)

1.1 Externally Imposed Requirements.

Documents which contain functional requirements that are hereby incorporated as 802.11 functional requirements:

- 802 Functional Requirements (document number P802-91/152).
- 802.11 PAR (P802.11-91/58)
- The 802.11 PAR supersedes the 802 Functional Requirements (P802-91/152) where they conflict.

1.2 General Requirements.

The primary service provided by 802.11 is to deliver MSDUs between LLCs.

Continuity of service to the layers within an ESS will be supported.

The MAC must accommodate any PHY transmission rate between 1 and 20 Mbit/s.

The 802.11 MAC and PHY will support the application described in the 802.11 Market Requirements Document.

Any function or service unique to wireless networks will be handled within the 802.11 standard.

802.11 will support multicast services (including broadcast services).

The standard will support network management services.

1.3 Data Service Types.

802.11 will provide two classes of MSDU delivery service:

- 1) An asynchronous MSDU delivery service.
- 2) a Time-bounded MSDU delivery service.

All 802.11 implementations will support the asynchronous class service.

Stations using the asynchronous and/or time-bounded service must coexist within the same BSS.

1.4 Coordination Functions.

All 802.11 implementations will support a common default coordination function.

There will be a method for dynamically switching from the default coordination function and any other defined coordination function.

A single MAC shall be used to support all coordination functions.
There shall be mechanisms defined to resolve medium use conflicts.

I.5 MAC / PHY Interface.

A single MAC will be used to support multiple PHYs.

A single MAC/PHY interface will be defined.

If the MAC/PHY interface is exposed, a conformant implementation must adhere to the defined MAC/PHY interface.

I.6 Security.

The standard shall support registration services.

The standard shall support authentication services.

LIST OF REFERENCES

1. Metcalf, Andrew C. "Analysis of Multimedia Information Systems for the U. S. Coast Guard", March, 1992: Thesis document at Naval Postgraduate School, Monterey, CA.
2. Schatt, Stan. *Understanding Local Area Networks*. Carmel, IN.: SAMS, 1992
3. Ovan, Mil. "Requirements For Wireless Local Area Networks." Unpublished Paper, Motorola, Inc., not dated material.
4. Stalling, William. *Data And Computer Communications*. New York, NY.:Macmillan Publishing Company, 1991.
5. Gilbert, Barry. "To cable or not to cable? Wireless LANs enter the market place." LAN Times March 23 1992: 37(2).
6. Frank, Alan. "Networking Without Wires", Lan Technology, March 1992 v8 n3, p51(10)
7. Hogan, Mike. "Wireless networks find their niche; new products allow new flexibility for installations.", PC World, Dec 1991, v9 n12, p72(1)
8. No Author, Network hardware. "LAN Buyers Guide: Network Hardware", LAN Magazine, August 1992 v7 n8 p(10)46, COPYRIGHT MILLER FREEMAN PUBLICATIONS 1992
9. Geier, James T. "Wireless LAN Implementation" ,IEEE Conference on Wireless Local Area Network Implementation, September 17, 1992.
10. E-Mail message to the author and LCDR Mike Greenauer, Directorate, Project Management, Code 03, Naval Medical Information Management Center, Bethesda, MD, April 5, 1993.
11. Naval Postgraduate School, class material from IS3502 Computer Networks: Wide Area and Local Area, Fall Qtr 1992. By Dr. Myung W. Suh.

12. Derfler, Frank J., Jr., "Connectivity simplified: an introduction to the ways of networking." (part one of a two-part series) (includes related article on comparing signaling speed and throughput, summary of article's highlights and glossary of terms) (Tutorial), PC Magazine, March 31 1992 v11 n6 p251(17)
13. Carr, Jim. "Wireless Networking." LAN MAGAZINE November 1991, 23-24.
14. Clegg, Peter., "Wireless Technology Cuts Cabling Needs, Before you install the cables, consider this technology's capabilities", LAN Times, April 15, 1991, p(35-36)
15. Berline, Gary, Perratore, Ed. "Portable, Affordable, Secure Wireless LANs." PC Magazine February 11, 1992: 291-312
16. INFRALINK of America, Inc. Pamphlets from company.
17. Clegg, Peter. "BICC Infralan." LAN TIMES, July 8, 1991, volume 8, issue 13: No page numbers.
18. Saunders, Stephen, "Wireless LANs: Closer to Cutting the Cord", Data Communications, March 21, 1993: 59-64.
19. InfraLAN Technologies Inc. literature, 12 Craig Road Action, MA 01720
20. Mahaugh, Doug. "Set up remote data entry." Data Base Advisor Jan 1993 v11 n1: p61(8).
21. Ubois, Jeff. "Wireless LANs are due for an encore. (infrared local area networks, spread-spectrum radio gaining in popularity)" Coastal Associates Publishing L.P. 1993. (MacWEEK Special Report: Wireless Communications)
22. Homer, Blaine. "Light and radio: today's choices for a mobile workstation (infrared light or wireless radio connections)" LAN Times August 10, 1992 v9 n15: p55(1)
23. No author, "Narrow band or spread spectrum: which one is right for you? (Advertising Supplement: LXE; User Questions & Answers)." Digital News & Review Sept 28 1992 v9 n18:p49(4)
24. Motorola Inc., Motorola's Altair VistaPoint Inter/Intra-Building Wireless Ethernet LAN, Product Application and Technology White Paper, Wireless Enterprise Systems Motorola Inc.: p 1-10.

25. Heiman, Fred P. Ph.D., "Spread Spectrum Technology" SYMBOL Monograph Series, Symbol Technologies, Inc. 1991: 1-13.
26. Dixon, Robert C. *Spread Spectrum Systems Second Edition*. New York, NY.: John Wiley & Sons, 1984.
27. Wallace, Scott. "Cutting the Cord." CIQ May 1991: 108-111
28. Michalski, Jerry. "A short trip indoors (wireless networks)." Venture Holding Inc. Oct 31 1992: p17(8)
29. Pickholtz, Raymond L., Donald L. Schilling, and Laurance B. Milstein. "Theory of Spread-Spectrum Communications -- A Tutorial." IEEE Transaction of Communications, Vol. COM-30, NO. 5, May 1982: 855-869.
30. NCR Corporation, Product information package.
31. No author, "Special report: Windata Freeport Wireless LAN." The LocalNetter July 1992 v12 n7: p28(1).
32. Telephone conversation between LCDR Len Hurd, Naval Medical Information Management Center, and the author March 1993.
33. Windata Incorporated, Product Information Package, received 10 Oct. 1992.
34. Freeman, Roger L. *Telecommunication Transmission Handbook* Third Edition. New York, NY.: John Wiley & Sons, Inc., 1991.
35. Hayes, V. "Radio-LAN Standardization Efforts." Proceedings of the IEEE conference on Wireless LAN implementation, Dayton, Ohio, September 1992: 3-4.
36. Waltz, Mitzi. "Does wireless technology present a health threat?" with Abstract, Computer Select, June 1993, Record number 13 498 072, for MacWeek March 8 1993 v7 n10 P28(1)
37. ALTAIR PLUS II WIRELESS ETHERNET LAN, PRODUCT APPLICATION AND TECHNOLOGY WHITE PAPER, p. 3.
38. McLachlan, Gordon, "Spread Spectrum Breaks Barriers," LAN Computing, June 1992, v3 n6, p. 1.

39. Gunn, Angela. "FUTURECURRENTS: Where Wireless Technology Is Headed.", PC Magazine, February 11, 1992 p304(2)

40. Eckerson, Wayne. "Revolution in the air", Network World, June 15, 1992, p68

INITIAL DISTRIBUTION LIST

Defense Information Technology Services Organization DITSO-GA 6760 E. Irvington Place Denver, Colorado 80279	1
Defense Information System Agency 1951 Kidwell Dr. Vienna, VA 22182	1
Defense Technical Information Center Cameron Station Alexandria, VA 22304-6145	1
Library, Code 52 Naval Postgraduate School Monterey, CA 93943-5002	1
Commanding Officer Naval Medical Information Management Center 8901 Wisconsin Ave. Building 27 Bethesda, MD 20889-5600	2
Dr. Myung W. Suh Professor Code AS Naval Postgraduate School Monterey, CA 93943-5000	1
Dr. Tung Bui Academic Associate 367 Code AS/BD Naval Postgraduate School Monterey, CA 93943-5000	1
LT Charles L. McBee 121 Linden Dr. Security, CO	5

**Bill Wilson
Rt 1 Box 1144
Shelbyville, TX 75973**

1