



Analysis of Surface Warfare Enterprise's implementation of enterprise management practices

Title	Analysis of Surface Warfare Enterprise's implementation of enterprise management practices
Item Type	Thesis
Authors	Castle, Brandon S.;Massie, James G.
URI	https://hdl.handle.net/10945/10485
Publisher	Monterey, CA; Naval Postgraduate School
Date Issued	2010-12
Rights	This publication is a work of the U.S. Government as defined in Title 17, United States Code, Section 101. Copyright protection is not available for this work in the United States.
Download date	2026-04-14 04:31:31
Link to Item	https://hdl.handle.net/10945/10485

Downloaded from NPS Archive: Calhoun



**NAVAL
POSTGRADUATE
SCHOOL**

MONTEREY, CALIFORNIA

MBA PROFESSIONAL REPORT

**Analysis of Surface Warfare Enterprise's Implementation of Enterprise
Management Practices**

**By: Brandon S. Castle
James G. Massie III
December 2010**

**Advisors: Douglas A. Brook
Phillip J. Candreva**

Approved for public release; distribution is unlimited

THIS PAGE INTENTIONALLY LEFT BLANK

REPORT DOCUMENTATION PAGE			<i>Form Approved OMB No. 0704-0188</i>
Public reporting burden for this collection of information is estimated to average 1 hour per response, including the time for reviewing instruction, searching existing data sources, gathering and maintaining the data needed, and completing and reviewing the collection of information. Send comments regarding this burden estimate or any other aspect of this collection of information, including suggestions for reducing this burden, to Washington headquarters Services, Directorate for Information Operations and Reports, 1215 Jefferson Davis Highway, Suite 1204, Arlington, VA 22202-4302, and to the Office of Management and Budget, Paperwork Reduction Project (0704-0188) Washington DC 20503.			
1. AGENCY USE ONLY (Leave blank)	2. REPORT DATE December 2010	3. REPORT TYPE AND DATES COVERED MBA Professional Report	
4. TITLE AND SUBTITLE Analysis of Surface Warfare Enterprise's Implementation of Enterprise Management Practices		5. FUNDING NUMBERS	
6. AUTHOR(S) Brandon S. Castle, James G. Massie III		8. PERFORMING ORGANIZATION REPORT NUMBER	
7. PERFORMING ORGANIZATION NAME(S) AND ADDRESS(ES) Naval Postgraduate School Monterey, CA 93943-5000		10. SPONSORING/MONITORING AGENCY REPORT NUMBER	
9. SPONSORING /MONITORING AGENCY NAME(S) AND ADDRESS(ES) N/A		11. SUPPLEMENTARY NOTES The views expressed in this thesis are those of the author and do not reflect the official policy or position of the Department of Defense or the U.S. Government. IRB Protocol number <u>NPS.2010.0105-IR-EP7-A</u> .	
12a. DISTRIBUTION / AVAILABILITY STATEMENT Approved for public release; distribution is unlimited		12b. DISTRIBUTION CODE	
13. ABSTRACT (maximum 200 words) The Navy's future success relies on its ability to improve its current level of readiness in an environment of limited budgets. The enterprise concept has been the Navy's tool to meet this fiscal challenge. Through better resource allocation, Navy Enterprise seeks to maximize return on investment (ROI). Previous projects have analyzed the results from Sea Enterprise through 2005 and Naval Aviation Enterprise through 2007. Addressing enterprise management in the surface warfare community expands this body of knowledge. This project focuses on enterprise practices in the surface navy. It analyzes how the Surface Warfare Enterprise (SWE) is organized, governed, led and attempted to determine if changes in resource allocation can be attributed to these practices. The results of this project reveal that SWE's application of enterprise management practices through organization, governance, and leadership is largely consistent with corporate enterprise models and recommendations, but also identifies some areas of inconsistency and potential challenges unique to SWE that must be managed carefully. The project identifies some changes in resource allocation that can be attributed to SWE, but is largely inconclusive. Further research into this area is recommended and a course of action is provided.			
14. SUBJECT TERMS Surface Warfare Enterprise, Return on Investment, Organization, Governance, Surface Board, Enterprise Management, Cross-Functional, Navy Enterprise, SWE.		15. NUMBER OF PAGES 129	
		16. PRICE CODE	
17. SECURITY CLASSIFICATION OF REPORT Unclassified	18. SECURITY CLASSIFICATION OF THIS PAGE Unclassified	19. SECURITY CLASSIFICATION OF ABSTRACT Unclassified	20. LIMITATION OF ABSTRACT UU

THIS PAGE INTENTIONALLY LEFT BLANK

Approved for public release; distribution is unlimited

**ANALYSIS OF SURFACE WARFARE ENTERPRISE'S IMPLEMENTATION
OF ENTERPRISE MANAGEMENT PRACTICES**

Brandon S. Castle, Lieutenant, United States Navy
James G. Massie III, Lieutenant, United States Navy

Submitted in partial fulfillment of the requirements for the degree of

MASTER OF BUSINESS ADMINISTRATION

from the

**NAVAL POSTGRADUATE SCHOOL
December 2010**

Authors:

Brandon S. Castle

James G. Massie III

Approved by:

Douglas A. Brook, Lead Advisor

Phillip J. Candreva, Support Advisor

William R. Gates, Dean
Graduate School of Business and Public Policy

THIS PAGE INTENTIONALLY LEFT BLANK

ANALYSIS OF THE SURFACE WARFARE ENTERPRISE'S IMPLEMENTATION OF ENTERPRISE MANAGEMENT CONCEPTS

ABSTRACT

The Navy's future success relies on its ability to improve its current level of readiness in an environment of limited budgets. The enterprise concept has been the Navy's tool to meet this fiscal challenge. Through better resource allocation, Navy Enterprise seeks to maximize return on investment (ROI). Previous projects have analyzed the results from Sea Enterprise through 2005 and Naval Aviation Enterprise through 2007. Addressing enterprise management in the surface warfare community expands this body of knowledge.

This project focuses on enterprise practices in the surface navy. It analyzes how the Surface Warfare Enterprise (SWE) is organized, governed, led and attempted to determine if changes in resource allocation can be attributed to these practices.

The results of this project reveal that SWE's application of enterprise management practices through organization, governance, and leadership is largely consistent with corporate enterprise models and recommendations, but also identifies some areas of inconsistency and potential challenges unique to SWE that must be managed carefully. The project identifies some changes in resource allocation that can be attributed to SWE, but is largely inconclusive. Further research into this area is recommended and a course of action is provided.

THIS PAGE INTENTIONALLY LEFT BLANK

TABLE OF CONTENTS

I.	INTRODUCTION.....	1
A.	BACKGROUND	1
	1. Need for Navy Business Transformation.....	1
	2. Process Improvement in the Navy.....	3
	3. The Navy Enterprise.....	4
	<i>a. Development.....</i>	<i>4</i>
	<i>b. Mission</i>	<i>6</i>
	<i>c. Goal.....</i>	<i>6</i>
	<i>d. Structure</i>	<i>7</i>
	<i>e. Warfare Enterprises.....</i>	<i>9</i>
	4. Surface Warfare Enterprise (SWE).....	10
B.	RESEARCH	11
	1. Primary Research Question.....	11
	2. Supporting Research Questions.....	11
C.	BENEFIT OF PROJECT.....	12
D.	PROJECT SCOPE.....	12
E.	METHODOLOGY	12
F.	ORGANIZATION OF PROJECT	13
II.	LITERATURE REVIEW	15
A.	INTRODUCTION.....	15
B.	ORGANIZATION AND LEADERSHIP.....	15
	1. George Labovitz With Victor Rosansky: <i>The Power of Alignment: How Great Companies Stay Centered and Accomplish Extraordinary Things</i>	15
	<i>a. The Main Thing</i>	<i>16</i>
	<i>b. Staying Centered.....</i>	<i>17</i>
	<i>c. Distributed Leadership.....</i>	<i>18</i>
	2. Terence T. Burton With John W. Moran: <i>The Future Focused Organization: Complete Organizational Alignment for Breakthrough Results</i>	20
	<i>a. Levels of Management.....</i>	<i>20</i>
	<i>b. Leadership</i>	<i>22</i>
	3. Dan Dimancescu: <i>The Seamless Enterprise: Making Cross Functional Management Work</i>	24
	<i>a. Definition of Cross Functions.....</i>	<i>25</i>
	<i>b. Cross Function Team Composition.....</i>	<i>25</i>
C.	GOVERNANCE.....	25
	1. Margot Cairnes. <i>Boardrooms That Work: A Guide to Board Dynamics</i>	25
	<i>a. Board Processes</i>	<i>26</i>
	<i>b. Board Malfunctions</i>	<i>27</i>
	<i>c. Board Dynamics.....</i>	<i>27</i>

	d.	<i>Board Culture</i>	29		
	2.	Phillip J. Streatfield: <i>The Paradox of Control in Organizations</i>	29		
		a.	<i>Mainstream Understanding of Control</i>	29	
		b.	<i>Complex Responsive Process</i>	30	
		c.	<i>Management Participation in the Construction of</i> <i>Meaning</i>	31	
	D.	SUMMARY	32		
III.		SURFACE WARFARE ENTERPRISE	35		
	A.	INTRODUCTION.....	35		
	B.	SWE DEFINED.....	36		
	C.	IMPLEMENTATION OF ENTERPRISE MANAGEMENT	36		
		1.	Beginning Initiatives	36	
			a.	<i>SHIPMAIN</i>	37
			b.	<i>SHIPTRAIN</i>	40
		2.	SWE Launch.....	41	
		3.	NAE Influence	43	
		4.	SWE Development November 2005–March 2008.....	44	
		5.	SWE Development March 2008–Current.....	47	
		6.	Enterprise Maturity Model.....	49	
	D.	ORGANIZATION AND ALIGNMENT.....	51		
		1.	Horizontal Elements	52	
		2.	Vertical Elements	54	
	E.	GOVERNANCE.....	56		
		1.	Surface Board Responsibilities	56	
		2.	Membership.....	57	
		3.	SWE Governance Support.....	57	
	F.	LEADERSHIP	58		
		1.	SWE Commander (CNSF).....	58	
		2.	SWE Deputy Commander (NAVSEA).....	59	
		3.	CFT Leadership	59	
	G.	RESOURCE ALLOCATION	60		
		1.	Money.....	60	
		2.	Manning.....	61	
			a.	<i>Top Six Roll Down</i>	62
			b.	<i>Optimal Manning</i>	63
	H.	SUMMARY	63		
IV.		ANALYSIS OF SWE ENTERPRISE MANAGEMENT IMPLEMENTATION	67		
	A.	INTRODUCTION.....	67		
	B.	ANALYSIS OF SWE ORGANIZATION.....	67		
		1.	SWE’s Main Thing	68	
			a.	<i>Strategy</i>	70
			b.	<i>Processes</i>	71
			c.	<i>Customers</i>	71
			d.	<i>People</i>	71

2.	Vertical and Horizontal Elements	72
3.	Levels of Management.....	73
a.	<i>Strategic Management</i>	74
b.	<i>Lateral Management</i>	75
c.	<i>Daily Management</i>	76
4.	Review Table	77
C.	ANALYSIS OF SWE GOVERNANCE	78
1.	Board Processes.....	79
2.	Board Malfunctions	79
3.	Board Dynamics	79
4.	Board Culture.....	80
5.	Review Table	81
D.	ANALYSIS OF SWE LEADERSHIP	81
1.	Leadership Distribution	82
2.	Responsibilities.....	83
3.	Behavior	84
a.	<i>Chosen Thought</i>	84
b.	<i>Conscious Speech</i>	84
c.	<i>Consistent Action</i>	85
d.	<i>Constant Care</i>	85
4.	Review Table	86
E.	SUMMARY	86
V.	CONCLUSIONS AND RECOMMENDATIONS.....	89
A.	INTRODUCTION.....	89
B.	CONCLUSIONS	90
1.	Primary Research Question:.....	90
a.	<i>Organization</i>	90
b.	<i>Governance</i>	91
c.	<i>Leadership</i>	91
2.	Supporting Research Questions.....	92
C.	RECOMMENDATIONS.....	93
D.	SUGGESTIONS FOR FURTHER RESEARCH.....	95
	APPENDIX A	97
	APPENDIX B	99
	LIST OF REFERENCES.....	101
	INITIAL DISTRIBUTION LIST	105

THIS PAGE INTENTIONALLY LEFT BLANK

LIST OF FIGURES

Figure 1.	Institute Behavioral and Cultural Change. (From: Commander, Naval Surface Forces SWE Process Training Presentation, 2008)	2
Figure 2.	Navy Enterprise Evolution. (From: Navy Enterprise Presentation, 2010)	5
Figure 3.	Navy Enterprise Organizational Construct. (From: Navy Enterprise Presentation, 2010)	7
Figure 4.	Navy Enterprise Business Model. (From: Navy Enterprise Presentation, 2010)	8
Figure 5.	Navy Enterprise Framework. (From: Navy Enterprise Presentation, 2010).....	9
Figure 6.	Link to Elements. (From: Labovitz and Rosansky. 44, 1997)	18
Figure 7.	Management Structure. (From: Burton and Moran, 34, 1995)	22
Figure 8.	Four processes of good governance. (From: Cairnes, 2003.)	26
Figure 9.	SHIPMAIN PIT Structure. (From: NAVSEA SHIPMAIN Overview Presentation, February 2006)	38
Figure 10.	SHIPMAIN Helps USN Re-Capitalize. (From: NAVSEA SHIPMAIN Overview Presentation, February 2006)	39
Figure 11.	Total Projected SWE Savings and Cost Avoidance. (From: Perkins, 2007)...	42
Figure 12.	Naval Aviation Enterprise Structure. (From: Robert Williams, NPS Thesis, June 2007)	44
Figure 13.	CLASSRON Enterprise and Fleet Relationship. (From: Joint Industry Navy Improvements Initiative Meeting Presentation, 2007)	47
Figure 14.	EMM Management Rows (From: Commander, Naval Surface Forces. EMM Presentation, 2008)	50
Figure 15.	EMM Execution and Results Rows. (From: Commander, Naval Surface Forces. EMM Presentation, 2008)	51
Figure 16.	SWE Organization. (From: Commander, Naval Surface Forces SWE 101 Training Presentation, 2009).....	52
Figure 17.	SWE Vertical Alignment.	55
Figure 18.	SWE Element Links to its Main Thing.....	70
Figure 19.	SWE Management Structure.....	73
Figure 20.	Surface Board and Required Strategic Level Management Functions.	74
Figure 21.	CFT Responsibilities and Required Lateral Management functions.	76

THIS PAGE INTENTIONALLY LEFT BLANK

LIST OF TABLES

Table 1.	Framework for Analysis of SWE Organization.....	68
Table 2.	Summary of SWE Organization Analysis.	77
Table 3.	Framework for Analysis of Surface Board Governance.....	78
Table 4.	Summary of SWE Governance Analysis.....	81
Table 5.	Framework for Analysis of SWE Leadership.....	82
Table 6.	Summary of SWE Leadership Analysis.	86

THIS PAGE INTENTIONALLY LEFT BLANK

LIST OF ACRONYMS AND ABBREVIATIONS

ADM	Admiral
AIP	Action Item in Progress
ASQ	American Society for Quality
BOD	Board of Directors
BRT	Barrier Removal Team
BSO	Budget Submitting Office
C2	Command and Control
CAPT	Captain
CASREP	Casualty Reports
CDR	Commander
CEO	Chief Executive Officer
CFFC	US Fleet Forces Command
CFO	Chief Financial Officer
CFT	Cross-functional Team
CG	Guided Missile Cruiser
CLASSRON	Class Squadrons
CMMI	Capability Maturity Model Integration
CNAF	Commander, Naval Air Forces
CNAFR	Commander, Naval Air Forces Reserve
CNAL	Commander, Air Forces Atlantic
CNATRA	Chief of Naval Air Training
CNI	Commander, Naval Installations
CNO	Chief of Naval Operations

CNSF	Commander, Naval Surface Forces
CNSL	Commander, Naval Surface Forces Atlantic
COO	Chief Operating Officer
CPF	Commander, Pacific Fleet
CRO	Chief Readiness Officer
CRT	Current Readiness Team
CSG	Carrier Strike Group
DCNSF	Deputy Commander, Naval Surface Forces
DDG	Guided Missile Destroyer
DESRON	Destroyer Squadron
DON	Department of the Navy
ECH	Echelon
EMM	Enterprise Maturity Model
EN	Engineman
ESG	Expeditionary Strike Group
EXCOMM	Executive Committee
FCT	Future Capabilities Team
FFC	Fleet Forces Command
FFG	Frigate
FRE	Fleet Readiness Enterprise
FRP	Fleet Response Plan
FRT	Future Readiness Team
FY	Fiscal Year
GAO	Government Accountability Office
IDTC	Inter-deployment Training Cycle

i-ENCON	Incentivized Energy Conservation
INSURV	Board of Inspection and Survey
ISIC	Immediate Superior in Command
JUSE	Japan Union of Scientists and Engineers
LANT	Atlantic
LCAC	Light Cushioned Air Controlled
LCM	Landing Craft Mechanized
LCS	Littoral Combat Ship
LCU	Landing Craft Unit
LHA	Amphibious Assault Ship
LHD	Amphibious Landing Dock
LPD	Amphibious Loading Dock
LPO	Leading Petty Officer
LSS	Lean Six Sigma
MCM	Mine Counter Measure Ship
MFOM	Maintenance Figure of Merit
NAE	Naval Air Enterprise
NAPPI	Naval Aviation Production Process Improvement Program
NAVAIR	Naval Air Systems Command
NAVSEA	Naval Sea Systems Command
NAVSUP	Naval Supply Systems Command
NECE	Navy Expeditionary Enterprise
NETC	Naval Education & Training Center
NETWARCOM	Naval Network Warfare Command
NMPC	Navy Military Personnel Command

NNFE	NETWAR/FORCEnet Enterprise
NPS	Naval Postgraduate School
NSAWC	Naval Strike Air Warfare Center
OMT	Overall Metrics Team
OPNAV	Office of the Chief of Naval Operations
OPTEVFOR	Operational Test & Evaluation Force
PAC	Pacific
PC	Coastal Patrol Ship
PEO	Program Executive Office
PESTO	People, Equipment, Supply, Training, and Ordnance
PHIBRON	Amphibious Squadron
PIT	Process Improvement Team
POM	Program Objective Memorandum
PPBE	Planning Programming Budgeting and Execution
PR	Program Review
PRT	Performance Readiness Team
QM1	Quartermaster First Class
QMC	Chief Quartermaster
RADM	Rear Admiral
RFF	Request for Forces
ROI	Return on Investment
SCT	Strategic Communications Team
SEBOD	Sea Enterprise Board of Directors
SES	Senior Executive Service
SFMT	Strategic Financial Management Team

SPAWAR	Space & Naval Warfare Systems Command
ST1	Surface Team One
SWE	Surface Warfare Enterprise
TFOM	Training Figure of Merit
TOC	Total Ownership Costs
TPS	Toyota Production System
TQC	Total Quality Control
TQM	Total Quality Management
TYCOM	Type Commander
ULTRA	Unit Level Training Assessment
USE	Undersea Warfare Enterprise
USFF	United States Fleet Forces
VADM	Vice Admiral
VTC	Video Telecommunication Connection

THIS PAGE INTENTIONALLY LEFT BLANK

ACKNOWLEDGMENTS

We would like to express our thanks to Professor Douglas Brook and Professor Philip Candreva, our project advisors. Thank you for the constructive critiques, and helping us put our thoughts on paper. Your support and guidance throughout this process truly made our research a valuable experience.

We would also like to express our appreciation to VADM D.C. Curtis (CNSF) for taking personal interest in our project and dedicating time to assist us during our search for information.

The N40 SWE Support Staff was invaluable during our research. LCDR Lisa Hodgson provided us tremendous support prior to and during our visit to CNSF. We would like to thank CDR John Kochendorfer, Mr. Bill Smith, and Mr. Peter Opsal for taking the time to provide us their experiences and insights. We would also like to thank CDR Darren McPherson for his hospitality and sincerity. Just prior to his ship's maiden deployment, he was still willing to take time and help us build a strong historical background on our project.

Brandon Castle's acknowledgements:

Most importantly, I would like to thank my wife, Leah, and daughters, Kaylene and Makenna. Their continuous love and support is always my source of encouragement and confidence.

James Massies's acknowledgements:

I would like to thank my wife, Meghan, for her constant support during the many hours spent in pursuit of my master's degree. I would also like to thank my children, Madeline and Jack, for their constant source of inspiration. Many thanks are given to the many sailors and marines I have had the pleasure of working with throughout my career.

THIS PAGE INTENTIONALLY LEFT BLANK

I. INTRODUCTION

A. BACKGROUND

1. Need for Navy Business Transformation

You can't be successful in leading this institution unless you become an expert in leading change.

ADM Vern Clark, CNO
8 September 2003

There is much change about...I see opportunity there and we will seize those opportunities.

ADM Gary Roughhead, CNO
11 October 2007

In October 2002, Admiral Vern Clark, then Chief of Naval Operations (CNO), formally introduced Sea Power 21 as the Navy's vision to confront the numerous challenges that would be faced in the 21st century. The goal of Sea Power 21 was to convert the present-day fleet from Cold War legacy technology into a modern, 21st century organization capable of executing missions that deter and defeat the country's enemies around the world, rapidly and cost effectively.¹ The initiative that was developed to address the business culture aspect of Sea Power 21 was Sea Enterprise. Through Sea Enterprise, Admiral Clark's focus was to align business efforts, accelerate progress, and realize the potential of people.²

The need for Navy business alignment took root as Navy leadership realized the inevitable budget constraints and rising costs of advanced systems needed in the future. Within the Navy, quality management and business re-engineering practices had already taken shape in Naval Air Systems Command (NAVAIR), but to economically replace and maintain the aging technology and systems of the Cold War era, the Navy needed to institute long term behavioral and cultural changes that transformed the way it did business as a whole. Figure 1 illustrates the business culture the Navy needed to move

¹ Gordon Meek, *Center for Navy Business Excellence: A Catalyst for Navy Business Transformation* (Master's thesis, Naval Postgraduate School, 2005), 4.

² *Ibid.*, 4.

away from, and what it desired to achieve. The trend that can be seen is a focus on process improvement and on developing a culture more accepting of change. In the past, Navy organizations have approached activities and decisions in a very stove-piped manner with minimal collaboration between groups, no end-product focus, and little consideration given to the long-term picture.³

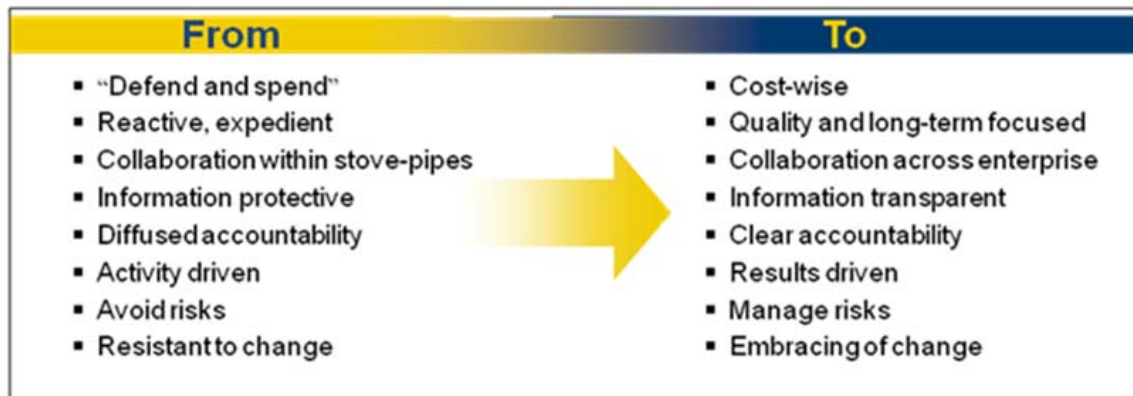

Figure 1. Institute Behavioral and Cultural Change. (From: Commander, Naval Surface Forces SWE Process Training Presentation, 2008)

With Sea Enterprise leading the Navy business transformation initiative, the Department of the Navy (DON) formed the Sea Enterprise Board of Directors (SEBOD) in March 2003 to execute existing business transformation initiatives and identify future savings opportunities to generate additional resources toward recapitalizing the fleet.⁴ In October 2004, this responsibility was turned over to the DON Business Council.⁵ In the late 21st century, the DON began implementing numerous business initiatives and processes that sought mainly to increase the efficiency of Navy-delivered services and products to the warfighters.⁶

³ Commander, Naval Surface Forces. *Surface Warfare Enterprise Process Presentation* (San Diego: 2008).

⁴ Meek, *Navy Business*, 2.

⁵ Ibid.,3.

⁶ Ibid.,3.

2. Process Improvement in the Navy

In the 1950s, Dr. Edward Deming and other quality specialists were brought in by Japanese industrialists to help produce better quality products. Through their teachings, the Japanese took the total quality control (TQC) philosophy and became world quality leaders in the 1970s, with most success in the auto industry.⁷ Observing the success of Japanese quality, U.S companies began adopting quality initiatives.

Mainstream process improvements in the Navy began in the 1980s, when NAVAIR adopted Total Quality Management (TQM). TQM was based heavily on the principles of TQC. NAVAIR's early TQM efforts led to substantial savings through acquisition streamlining, an increase in the number of mission-capable aircraft through the use of more reliable equipment, an improved spare parts inventory, and increased training for maintenance personnel.⁸ NAVAIR continued to introduce industry-proven continuous improvement business process methodologies (Lean, Theory of Constraints and Six Sigma) at the maintenance depot level in 1999, with the intent to deliver products to the fleet faster and at reduced costs.⁹

Lean manufacturing or production is a process management philosophy derived primarily from the Toyota Production System (TPS). Lean focuses on the reduction of wastes in products or services. Lean practices produced successful results in NAVAIR. Four hundred division power plants were able to reduce the engine turnaround time from eighty-three days in 2001 to fourteen days in 2002. NAVAIR also reduced excess capacity from nine repair sites to three, reduced excess repair site manpower from over three-hundred to around one-hundred fifty personnel and reduced excess inventory by retiring forty aircraft engines.¹⁰ In the late 1990s, the lean manufacturing concept also became practice in major Navy shipyards. Northrop Grumman Newport News (VA) shipyard began lean process improvements in supply chain management, engineering,

⁷ "TQM History," <http://www.quality-assurance-solutions.com/TQM-history.html>.

⁸ Raymond Malatino, *The NAVAIR TQM Revolution: Annual Quality Congress* (1991): 40-45.

⁹ Robert J. Williams, *Evaluation of Naval aviation Enterprise Airspeed's Generation of Measurable Cost Savings and Reinvestment for Recapitalization of the Future Navy and Marine Corps* (Master's thesis, Naval Postgraduate School, 2007), 2.

¹⁰ Wally Massenburg, *The Value of Enterprise Behavior* (Lemoore, CA 2005).

manufacturing, programs/assembly and test, and other areas.¹¹ In 2003, Northrop Grumman extended these lean practices to twelve of their suppliers resulting in 62 percent reduction in overall defect rates, lead-times down an average 35 percent, and on-time increased deliveries up to an average 91 percent from the previous 63 percent level.¹²

Originally developed by Motorola in the 1980s, Six Sigma is a process approach derived from statistics that seeks to identify and remove the causes of defects and errors in manufacturing and business processes. It combined TQM and other process improvement tools with a strong metrics approach to address defects. Lean Six Sigma (LSS) is a synergistic meshing of Lean and Six Sigma as a program that yields a customer-focused, enterprise change strategy to deliver increased capability, improved results, and desired culture change.¹³ In 2004, LSS initiatives were introduced to Naval Sea Systems Command (NAVSEA) and the DON partnered with the world's leading authority on quality, the American Society for Quality (ASQ) to develop a customized Lean Six Sigma Black Belt certification. As of 2008, 4,420 leaders had completed the LSS training.¹⁴

3. The Navy Enterprise

a. Development

The enterprise management concept was formally introduced to the Navy in Admiral Clark's Sea Enterprise initiative. Sea Enterprise sought to align all levels of the Navy's business and standardize practices such as TQM and LSS. NAVAIR led the enterprise initiative with the establishment of the Naval Aviation Enterprise (NAE) in 2004. The goal of the NAE was to operate as an enterprise with the goal of producing aircraft ready for tasking at reduced cost and recapitalize savings to pay for the aircraft of

¹¹ Lea A.P. Tonkin, "Northrop Grumman News: Reaching out to Suppliers" *Target Magazine*, 2006; 51-56.

¹² *Ibid.*, 53.

¹³ CNSF, *Enterprise Presentation*, 14.

¹⁴ Peter Peterka, *6 Six Sigma: Lean Six Sigma and the Navy*, 2008.

the future.¹⁵ With the success of AIRSpeed and the Naval Aviation Enterprise (NAE), the Navy took hold of the enterprise concept and spread it through all warfare areas. Today, this Navy-wide business transformation initiative is known as Navy Enterprise. Figure 2 illustrates the evolution of Navy Enterprise. In the 1990s, Navy business improvements were mainly working from the bottom up, starting with NAVAIR. In 2001, top Navy leadership began to incorporate business transformation into DON strategy and business transformation initiatives like Sea Enterprise began to work from the top down. In 2006, both dynamics combined to form the Navy Enterprise.

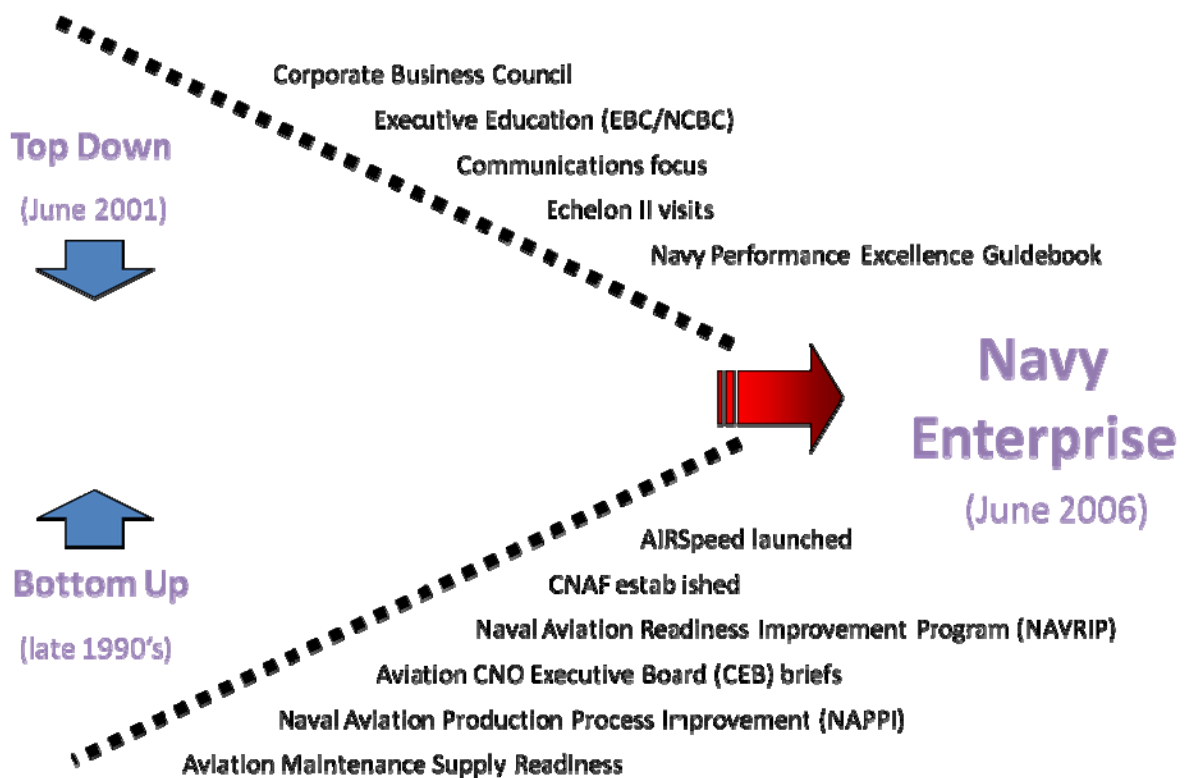

Figure 2. Navy Enterprise Evolution. (From: Navy Enterprise Presentation, 2010)

¹⁵ Wally Massenburg, *Enterprise Behavior*.

b. Mission

The purpose of Navy Enterprise as communicated by current senior leadership is:

It's about collaborating, sharing, and enhancing our business practices. Not to turn the Navy into a business, but to understand the business of the Navy so that we remain the most effective and efficient Navy in the world.

ADM Gary Roughhead, CNO
March 2008

The environment that the Navy is operating in is complex and challenging and the range of operations is growing. In addition to the traditional Navy core capabilities of forward presence, deterrence, sea control, and power projection, the new Maritime Strategy also calls for expanded capabilities such as maritime security, and disaster relief and humanitarian assistance.¹⁶ The Navy's cost continues to grow as well and is projected to increase significantly greater than the rate of inflation. In order to cost-effectively execute the Maritime Strategy, the Navy needs the ability to re-capitalize and improve the Return on Investment (ROI). The Navy Enterprise initiative supports efforts within and across Navy headquarters and individual commands to improve ROI.

c. Goal

The ultimate goal or end state that Navy Enterprise is designed to achieve is a decentralized structure of all elements of the Navy organization. This structure should continually work together towards a common purpose of delivering the Navy's contribution to the defense of the United States in the right quantity, at the right time, and at the right cost.¹⁷

¹⁶ Navy Enterprise, *Navy Enterprise* (San Diego CA, 2008).

¹⁷ Ibid.

d. Structure

To understand the Navy Enterprise structure, it is important to distinguish the differences between the major enterprise components, the Fleet Readiness Enterprise (FRE) and the Provider Enterprise. Figure 3 illustrates the alignment and responsibilities of the Navy Enterprise organization.

Navy Enterprise Organizational Construct

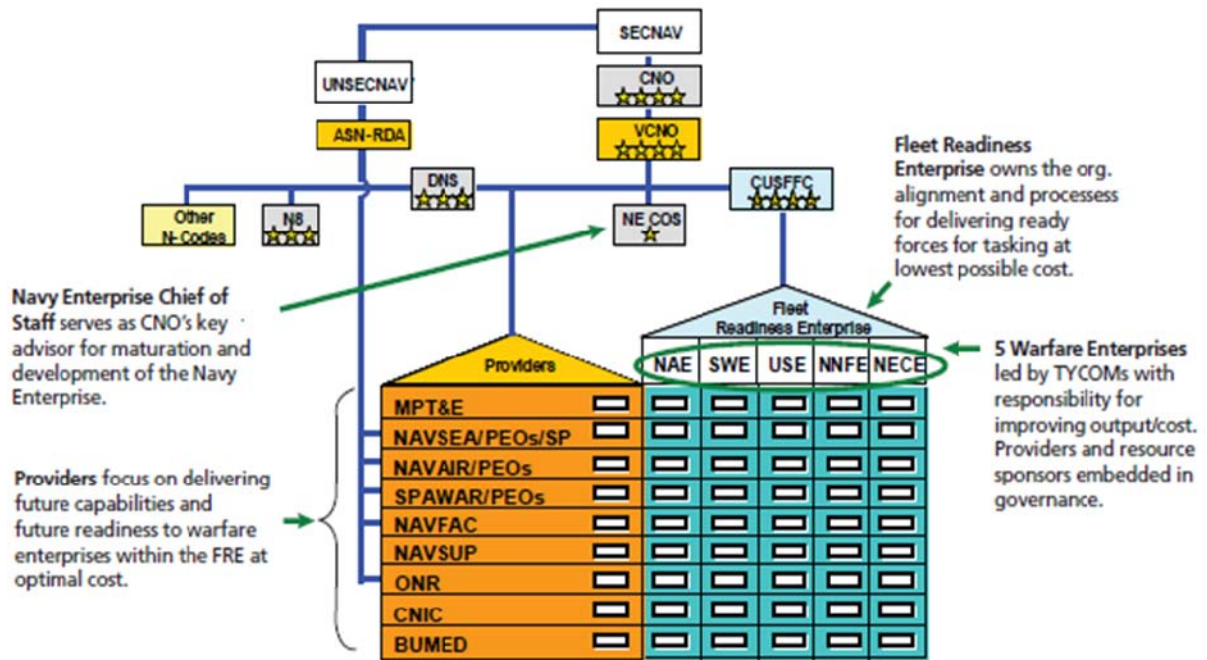

Figure 3. Navy Enterprise Organizational Construct. (From: Navy Enterprise Presentation, 2010)

FRE is led by Commander, U.S. Fleet Forces Command (CFFC) and governs five individual warfare enterprises. The FRE is responsible for managing the organization alignment and processes between the warfare enterprises and providers. FRE has a cohesive chain of command with the goal of ensuring forces ready for tasking at the lowest cost with its main focus on current fleet readiness. The provider enterprise construct is not similar to the FRE. It is composed of nine different providers and associated Program Executive Offices (PEOs). They work separately and together to

deliver future capabilities and support current readiness to the warfare enterprises at the best available cost. The providers supply manpower, assets, parts, supplies, research and development, health care, and supporting infrastructure to the FRE and other providers.¹⁸ Since there is no common output and providers often support different customers, its command structure is not as cohesive as the FRE. Figure 4 better illustrates the Navy Enterprise business model and how each entity in the enterprise collaborates.

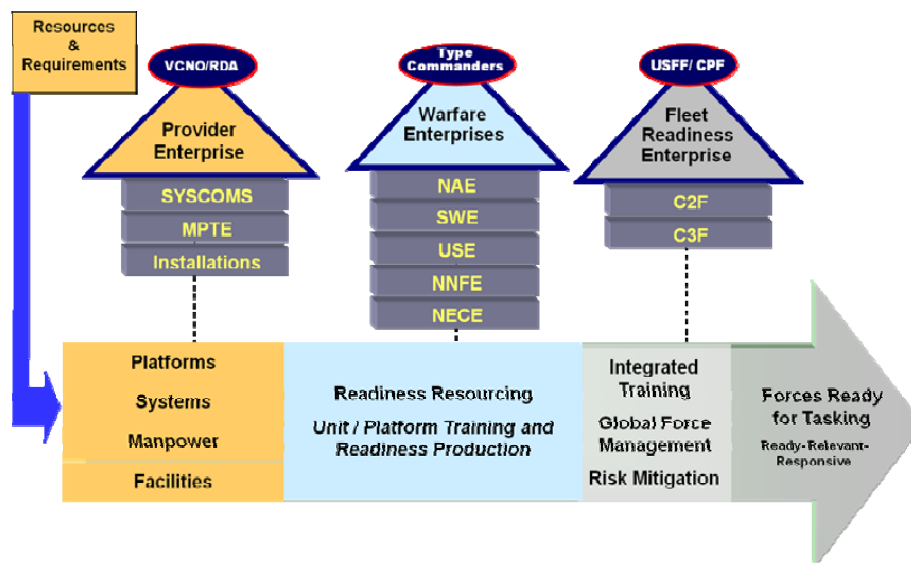

Figure 4. Navy Enterprise Business Model. (From: Navy Enterprise Presentation, 2010)

The FRE and the five warfare enterprises are focused on maintaining current levels of fleet readiness in the constraints of a budget. The challenge that providers face is supporting the current level of readiness but also looking into the future to determine what capabilities will be needed and at what capacity.

Another important distinction is the echelon framework. Echelon one represents the CNO, echelon two represents CFCC and Commander Pacific Fleet (CPF), and echelon three are the type commanders for each individual warfare enterprise. Figure 5 shows the Command and Control (C2) function of this echelon framework.

¹⁸ Navy Enterprise, *Navy Enterprise*.

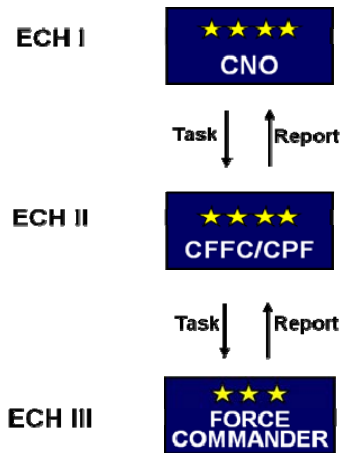

Figure 5. Navy Enterprise Framework. (From: Navy Enterprise Presentation, 2010)

e. Warfare Enterprises

Navy Enterprise is structured around five individual warfare enterprises. Each warfare enterprise is supported by its providers and resource sponsors. The FRE governs all five enterprises and ensures the warfare and provider enterprises collaborate. Each warfare enterprise is responsible to provide units ready for tasking in each of their assigned warfare area. Every major warfare community in the Navy is represented by an enterprise.

(1) Navy Expeditionary Combat Enterprise (NECE).

Establishes processes and behavioral constructs to achieve greater efficiency and reduce costs and plans to develop metrics subsequently. The enterprise is led by the Commander, Navy Expeditionary Combat Command.¹⁹

(2) Undersea Warfare Enterprise (USE). Focuses on

increasing effectiveness and efficiency by improving the operational availability of the submarine fleet, improving commanding officer decision making, ensuring the presence of experienced submarine personnel throughout the defense community, and generating the capability required to maintain undersea superiority in the future.²⁰

¹⁹ Jessie Riposo et al., *Navy Enterprises, Evaluationg Their Role in Planning, Programming, Budgeting and Execution (PPBE)*. (Santa Monica CA: RAND, 2009), 8.

²⁰ *Ibid.*, 8.

(3) NETWAR/FORCEnet Enterprise (NNFE). Its mission is to provide and operate a global network to win battles in the Information Age. NNFE is involved in the business of command, control, communications, computers, collaboration, and intelligence and information operations.²¹

(4) Naval Air Enterprise (NAE). Support the warfighter by providing combat-ready naval aviation forces. The NAE measures efficiency and effectiveness by aviation units ready for tasking at reduced cost, which is accomplished by improved reliability, process efficiencies, reduced cycle time and other efforts.²²

(5) Surface Warfare Enterprise (SWE). Its mission is to provide combat-ready surface forces to the fleets and combatant commanders.²³

4. Surface Warfare Enterprise (SWE)

The Surface Warfare Enterprise (SWE) was established in 2005, shortly after NAE. SWE is headed by Commander Naval Surface Forces (CNSF) and exists to provide surface warships fully ready for tasking to fleet commanders in order to meet combatant commander war fighting requirements.²⁴ To achieve this mission, SWE primarily focuses on providing the surface navy with trained sailors and ready warships through joint enterprise processes that balance risk and return on investment (ROI).

In recent years, the surface navy has been facing a decline in readiness. Cost-cutting decisions that have been made throughout the last two decades have severely degraded ship readiness.²⁵ This degradation has been a result of focus on efficiencies and interrelated decisions to reduce manning, alter the training process, and restructure maintenance.²⁶ In 2008, SWE leadership was able to identify how these separate efficiency initiatives established in the early 2000s have combined to cause dramatic

²¹ Riposo et al., *Navy Enterprises*, 8.

²² *Ibid.*, 8.

²³ Riposo, *PPBE*, 8.

²⁴ CNSF, *Enterprise Presentation*.

²⁵ Admiral J C Harvey, Jr Commander, US Fleet Forces Command Congressional Testimony 111th Cong., 2nd sess., Cong. Rec. (28 July 2010).

²⁶ Phillip Ewing, "USNs Lean Manning Backlash," *Defense News* (2010): 1.

reductions in surface combatant effectiveness. A Fleet Review Panel commissioned by ADM John Harvey (CFFC) in early 2010 verified what SWE leadership had previously found.

With fiscal challenges growing in upcoming years, SWE practices will be vital to correcting and improving surface fleet readiness. For the fiscal 2012 budget request, Defense Secretary Gates has challenged each military branch to find billions of dollars in overhead savings with an incentive to re-invest the costs that are cut back into their budgets so force size does not diminish.²⁷ As the Navy's 2012 budget is scrutinized, SWE business practices must be efficient at all levels so re-allocated savings can improve the future readiness of the surface fleet. A better knowledge foundation of the Navy Enterprise concept, by analyzing SWE leadership, governance, and resource allocation since its establishment in 2005 will provide information that can help the Navy's business transformation agenda move forward.

B. RESEARCH

This research draws upon the efforts of SWE from 2005 through the present and analyzes how SWE is organized, governed, and led. The research attempts to recognize the changes in resource allocation that can be directly attributed to SWE.

1. Primary Research Question

How was enterprise management implemented in Surface Warfare Enterprise; how is it organized, governed and led?

2. Supporting Research Questions

- To what extent have there been changes in resource allocation?
- Can these changes in resource allocation be attributed to SWE?

²⁷ Jean DiMascio, "Gates Gears up for Cuts Fight," August 10, 2010, <http://www.politico.com/news/stories/0610/38643.html>.

C. BENEFIT OF PROJECT

This project provides an analysis of Surface Warfare Enterprise and builds on a body of knowledge from earlier studies of Sea Enterprise and Naval Aviation Enterprise. It will provide an analysis of the relationship between the organization and governance of SWE and changes in resource allocation.

The purpose of this project is to present a broad analysis and better understanding of how the SWE effort is contributing to the Navy's return on investment and business transformation agenda. This analysis will build a better knowledge foundation of the Enterprise concept in the Navy and contribute to greater understanding of Navy efforts to align organizations and programs in a constrained fiscal environment.

D. PROJECT SCOPE

This project provides an external look at the Surface Warfare Enterprise and how it has implemented enterprise management practices through organization, governance, and leadership. The time frame covered will be FY-2005 through FY-2010 to allow a then and now comparison following the implementation of SWE in 2005.

E. METHODOLOGY

This project reviews the background and examines the implementation of enterprise management in SWE. It attempts to identify how enterprise behavior and models were used in the development of SWE's organization, governance, and leadership. It also investigates what changes in resource allocation can be attributed to enterprise management. Through the review and analysis of SWE history, strategic plans, organizational charts, training presentations, and interviews of key SWE personnel, this project formulates a more clear understanding of how SWE has implemented enterprise management behavior and practices.

A literature review of relevant topics related to enterprise management concepts was conducted. This literature review focused on organizational alignment, cross-functional management, organizational governance, and leadership. A review of previous research on enterprise management in Sea Enterprise and Naval Aviation Enterprise was also conducted and used in the project.

A series of interviews was conducted with senior level surface military leaders and civilian personnel. Interviews were scheduled by e-mail through the N40 SWE support staff and conducted at Surface Forces Headquarters and onboard USS Sterret (DDG 104) in San Diego. All personnel interviewed held elite and specialized positions within SWE. Each interview was transcribed and methodically reviewed for trends that could explain how enterprise management has worked within SWE. Based on a thorough literature review and data collection, an analysis was conducted to evaluate how enterprise management has been implemented in SWE, and how it is contributing (or not contributing) to resource allocation.

F. ORGANIZATION OF PROJECT

This project is presented in the following order:

This chapter, Chapter I, establishes the historical background of how process improvement ideas and corporate business management concepts resulted in the development of the Navy Enterprise. It also presents the organizational construct of the Navy Enterprise and the relationships between individual warfare enterprises. Project purpose, scope, and methodology are also discussed.

Chapter II, Literature Review, provides framework of enterprise management concepts from which research findings can be discussed. The study of organization, governance, and leadership enables the analysis of SWE and how enterprise concepts are being implemented.

Chapter III, Surface Warfare Enterprise, presents archival research and interview data that is the basis for analysis of the primary research question. This chapter captures the history of SWE and discusses in detail how enterprise management was implemented through organization, governance, leadership. Data is also presented in an attempt to answer the supporting questions, but is ultimately not sufficient enough to support an appropriate analysis. An explanation for this is provided in the concluding chapter.

Chapter IV, Analysis of SWE Enterprise Management Implementation, provides an analysis of SWE based on an analytical framework drawn from the corporate literature

presented in Chapter II. It will specifically analyze SWE organization, governance, and leadership. Data provided from this analysis becomes the basis for the projects conclusions and recommendations.

Chapter V, Conclusions and Recommendations, presents conclusions and recommendations based on whether or not SWE's implementation of enterprise management conforms to the models and concepts discussed in Chapter II.

II. LITERATURE REVIEW

A. INTRODUCTION

This chapter presents background information from the literature related to concepts of enterprise management. Its purpose is to build a framework to analyze and discuss the findings that are presented in the remainder of this project. Organization through alignment is discussed through experiences of successful leading organizations. These authors discuss what is required for an organization to get and keep all vital elements aligned and headed in the same direction at the same time while remaining centered in a business reality of constant change. They also discuss the necessary levels of management, and leadership functions required for an organization to maintain a long-term future focus. Next, this chapter addresses how human behavioral dynamics interacts with corporate governance practices and structure. This section will also discuss organizational control as a paradox. Control is important to understand because it is a large factor in how an organization is governed, and how decisions about the future direction of an organization are made.

B. ORGANIZATION AND LEADERSHIP

1. **George Labovitz With Victor Rosansky: *The Power of Alignment: How Great Companies Stay Centered and Accomplish Extraordinary Things***

Labovitz and Rosansky have found through research and experience with clients in many different industries that growth and success in an organization are ultimately the result of alignment between four elements: people, customers, strategy, and processes.²⁸ To be successful during turbulent times, management must keep people focused and centered on a few key business objectives. To accomplish this, organizations must create a self-aligning and self-sustaining culture that distributes leadership and energy throughout the organization and unleash an organizational power they call “alignment.”²⁹

²⁸ George Labovitz and Victor Rosansky, *The Power of Alignment: How Great Companies Stay Centered and Accomplish Extraordinary Things* (USA: John Wiley and Sons, 1997), preface.

²⁹ Ibid., preface.

a. The Main Thing

According to Labovitz and Rosansky, every organization has a “Main Thing”—the single most powerful expression of what it hopes to accomplish. Its instrument for producing growth and profits must be a common and unifying concept to which every unit can contribute.³⁰ Labovitz and Rosansky state, “The greatest challenge that managers face today is keeping their people and organization centered on this main thing in the midst of change.”³¹ This challenge has two different aspects:

- (1) Get everyone headed in the same direction with a shared purpose.
- (2) Integrate resources and systems of the organization to achieve that shared purpose which they consider the main thing.³²

Determining and aligning an organization to this main thing is difficult, and through interviews with many successful chief executive officers (CEO), Labovitz and Rosansky found that these CEOs followed the same deceptively simple steps:

- (1) Carefully crafting and articulating the essence of their business and determining the main thing.
- (2) Defining a few critical strategic goals and imperatives and deploying them throughout their organizations.
- (3) Tying performance measures and metrics to those goals.
- (4) Linking these measures to a system of rewards and recognition.
- (5) Personally reviewing the performance of their people to ensure goals are met.³³

Constant connection to an organizations main thing is vital to its success. Many companies that attempted to implement improvement processes such as TQM,

³⁰ Labovitz and Rosansky, *The Power of Alignment*, 40.

³¹ *Ibid.*, 11.

³² *Ibid.*, 13.

³³ *Ibid.*, 13.

inadvertently fell into an activity trap with lots of teams working on lots of problems but with no connection to the main thing of the business.³⁴ Business re-engineering also did not create linkages between different parts of the business and perhaps its greatest weakness was a disregard for people, both managers and workers alike.³⁵ According to Labovitz and Rosansky, alignment links strategy and people and integrates them with customers and process improvement and ensures that everyone understands the main thing of the business.³⁶ Achieving this is not easy but sustaining it once it has been achieved is even more difficult.

b. Staying Centered

Labovitz and Rosansky state that aligning a department or business is similar to landing an airplane; it is an ongoing balancing act that involves setting direction, linking processes and systems, and making constant adjustments. If you fail to adjust, you will drift, over adjust and lurch from one side of your intended course to another.³⁷ The ability to stay centered around the main thing relies on two essential dimensions being in sync, vertical and horizontal.

(1) Vertical Alignment: The vertical dimension is concerned with organizational strategy and the people that are relied on daily to transform strategy into meaningful work.³⁸ When this is reached, all employees understand organization-wide goals and their role in achieving them. When executive level leaders and managers develop strategies in isolation from the people who execute them, it is inevitable that the strategies will not be successfully incorporated into the environment of the low level employees. This is the reason why continual feedback must be established between the two.

³⁴ Labovitz and Rosansky, *The Power of Alignment*, 25.

³⁵ *Ibid.*, 26.

³⁶ *Ibid.*, 26.

³⁷ *Ibid.*, 170.

³⁸ *Ibid.*, 170.

(2) Horizontal Alignment: The horizontal dimension involves the business processes that create what the customer values most.³⁹ It eliminates the boundaries between the organization and the customer and incorporates the customer into the decision making process.

Labovitz and Rosansky demonstrate through figure 6 the dynamic relationship that exists between the four elements when alignment is achieved in both vertical and horizontal dimensions.

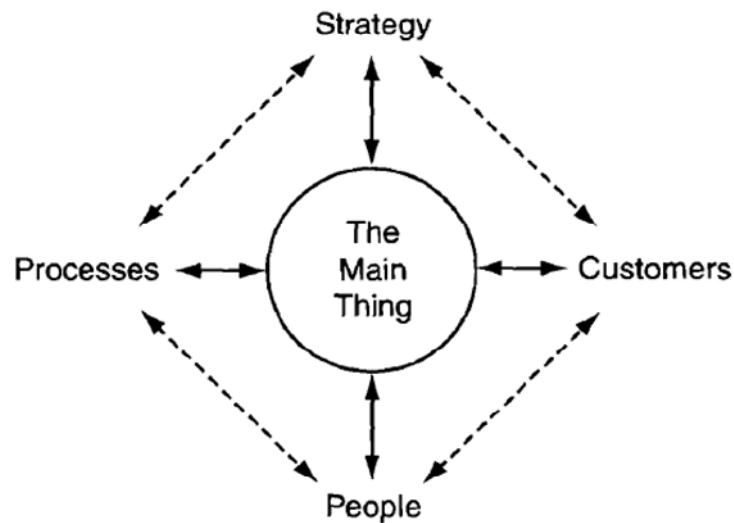

Figure 6. Link to Elements. (From: Labovitz and Rosansky. 44, 1997)

c. Distributed Leadership

Distributed leadership, according to Labovitz and Rosansky, is the glue of alignment. They define it as the presence of capable leadership in different units and at different levels of an organization.⁴⁰ The military has always set the example for corporate business when it comes to distributed leadership in action. However, there are still two different environments in which military leaders operate. To illustrate this, Labovitz and Rosansky use military leadership characteristics during peace-time and combat.

³⁹ Labovitz and Rosansky, *The Power of Alignment*, 170.

⁴⁰ Labovitz and Rosansky, *The Power of Alignment*, 44.

- (1) Peace Time Characteristics
 - No compelling mission or threat to galvanize efforts or stir emotions.
 - Objective is preparedness and self-maintenance.
 - Units engage in periodic training and busy work.
 - Things are done by the book with a tremendous emphasis on standard operating procedures (SOPs)
 - Little is left to the imagination or discretion of an individual soldier.
 - Prevailing attitudes include boredom, grouching and looking out for you.
- (2) Combat Characteristics
 - Military formality becomes the first casualty.
 - Hierarchy exists on paper but is replaced by organic behavior.
 - Mission is clear.
 - People forget differences and bond around a common goal.
 - People who bored are now engaged and emotionally charged.
 - Leaders are in situations which they must do their own thinking and acting.

According to Labovitz and Rosansky, an aligned company operates in a combat like environment where competition is intense, change is rapid, hierarchies exist but do not act like they are governed by them and are able to respond rapidly and in organic ways. Misaligned companies act like peace-time armies where clear objectives are lacking, employees don't see the purpose of their work and strong leadership only exists at the top.

In order to ensure an organization acts with the commitment and level of effort consistent with a combat unit, Labovitz and Rosansky offer practices that leadership must be able to accomplish. First, people must stay continually connected to the hostile environment in which they operate, and leadership must ensure everyone understands what is at stake. Second, help people think holistically. Leadership cannot

expect people to make the right decisions and do things beneficial to the organization if they cannot see the big picture. Third, the focus should always be on the main thing, and not on department specific goals. Fourth, reward and recognize people for working towards the main thing and not only for department specific goals. Fifth, use the review process to carry the message to employees, which will drive future behavior. Last, create opportunities for people to interact. A more effective working environment is established when people personally know and empathize with the other individuals of the organization.⁴¹

2. Terence T. Burton With John W. Moran: *The Future Focused Organization: Complete Organizational Alignment for Breakthrough Results*

Burton and Moran refer to a model which they call the *future-focused organization*. The focus of this model is on helping organizations and its leadership develop a future-focused strategic business development and deployment process.⁴² Two key aspects for an organization to meet its long-term objectives are levels of management and leadership.

a. Levels of Management

A future-focused organizational structure is very lean and is composed of three types of management: Strategic, Lateral, and Daily.

(1) Strategic Management. Strategic Management is a permanent structure in an organization that is focused on the development and deployment of strategic goals to all levels of the daily management work units.⁴³ According to Burton and Moran, the following are certain functions that strategic management must be able to accomplish:

- Focus on keeping the organization on the right course.
- Plan major shifts in emphasis, needs, and expectations.

⁴¹ Labovitz and Rosansky, *The Power of Alignment*, 44.

⁴² Terence Burton and John Moran, *The Future Focused Organization: Complete Organizational Alignment for Breakthrough Results* (Englewood Cliffs NJ: Prentice Hall, 1995), preface.

⁴³ *Ibid.*, 31.

- Work on common areas that are causing obstacles in accomplishment of the strategic goals.
- Align routine functional daily work with strategic effectiveness and efficiency goals.
- Develop the appropriate structure to meet the desired goals.

The strategic management level must be the external and future focus of the organization.⁴⁴ Even though strategic managers should not be involved in day-to-day issues, they do need to ensure that the daily management of the organization is properly aligned to the current and future needs of the organization.⁴⁵ If these are not aligned and structured correctly, it will create stress in the organization and cause a reduction in value-added work.

(2) Lateral Management (Cross Functional). Lateral Management is more of a temporary, alliance-based structure in the organization that concentrates on organization-wide flexibility goals and objectives.⁴⁶ This level of management is where solutions are developed that break down the boundaries of an organization. Lateral management focuses on the system and culture of the organization with its primary purpose being achievement of more fluid processes. It does this by defining the common areas between daily functional managers and by improving the flexibility of the organization.⁴⁷ Burton and Moran consider the following characteristics important for lateral management success:⁴⁸

- Management involvement based on inter divisional cooperation.
- A horizontal integration process to help an organization achieve efficient organization flexibility goals.
- Organizational barrier breaking approach that reduces complex layering.
- A process to deploy top level management functions.

⁴⁴ Burton and Moran, *Future Focused*, 33.

⁴⁵ *Ibid.*, 32.

⁴⁶ *Ibid.*, 33.

⁴⁷ *Ibid.*, 32.

⁴⁸ *Ibid.*, 35.

- A cultural change agent.
- A process to define the common ground between functional units to facilitate the flow of horizontal work.

(3) Daily Management. Daily management, like strategic, is a permanent but routine structure in an organization that focuses on the routine daily work that accomplish functions that convert inputs into outputs. Daily managers focus their respective work units on continuous improvement of their routine processes.⁴⁹ This level comprises a majority of the employees. It is internally focused but should be ready to adapt as the organization strategic management changes direction or emphasis. Figure 7 shows the structure of all three types of management.



Figure 7. Management Structure. (From: Burton and Moran, 34, 1995)

b. Leadership

Military leadership principles are much different when compared to corporate leaders. However, responsibility of leadership positions in an organization can be compared across different cultural lines. Burton and Moran define leadership in any organization as those responsible for the entire system.⁵⁰ Leadership does not necessarily mean one person in the organization. It applies to the group within an organization that sets the long-term course of the organization and enables and assists the rest of the

⁴⁹ Burton and Moran, *Future Focused*, 34.

⁵⁰ *Ibid.*, 62.

organization in accomplishing it.⁵¹ Burton and Moran argue that for an organization to have the capacity to achieve its long-term objectives, leadership must take on and execute certain responsibilities. These required functions are listed below:

- Develop and distribute the strategic plan.
- Explain, council, and coach lower level managers and units on how to accomplish the planned direction.
- Develop enthusiasm and trust in lower levels by empowering people, and delivering resources for them to accomplish the strategic direction they established.
- Ensure people understand what is expected, that their actions support it, and that everyone is held accountable for their actions, no matter what level.⁵²

In the past, organizations could focus on long-term change since the environment was more predictable.⁵³ For businesses the customer was obvious. For the government and military, the enemy was obvious. Now organizations have to change rapidly because the environment is constantly changing. This ability to adapt applies to all institutions including government.⁵⁴ In order to manage resources more effectively in a more uncertain environment, the navy has applied enterprise management across all warfare areas. Since this style of management is relatively new leadership has to be aware of certain behavioral functions. According to Burton and Moran, successful transformation into a different style of strategic long-term management requires leadership willing to practice and perform four critical behavioral functions: Chosen thought, conscious speech, consistent action, and constant care. These functions are explained in more detail below:

⁵¹ Burton and Moran, *Future Focused*, 62.

⁵² Burton and Moran, *Future Focused*, 30–70.

⁵³ *Ibid.*, 30–70.

⁵⁴ *Ibid.*, 30–70.

(1) Chosen Thought. focus on processes, data, and information sharing. Leadership must not default to thinking of people as the problem, but first focus on other parameters of a problem situation.

(2) Conscious Speech. sets the tone for cultural change that is necessary to achieve purpose. Leadership must focus on improvements, encourage questions, discuss critical processes, and focus on breakthroughs.

(3) Consistent Action. similar to Deming's constancy of purpose. Requires leadership to act the way they want others to act and respond.

(4) Constant Care. leadership must ensure people that they are on the right course and provide resources, training, rewards, and recognition for appropriate behavior and accomplishments.⁵⁵

The organizations that will be prepared to best handle the uncertain future with limited resources are those with leadership that can execute the responsibilities implied by their position, and embrace critical behavioral functions that will allow them to set a course, transform an organization, and lead all levels of the organization.

3. Dan Dimancescu: *The Seamless Enterprise: Making Cross Functional Management Work*

Dan Dimancescu defines and argues the importance of cross-functional management, first illustrating the background and issues organizations faced with a heavy vertical hierarchy: the issue of workers being too specialized and not understanding the whole system; numerous layers of command and control; and control of workers through reward and punishment. According to Dimancescu, this vertical management style led departments into their own specialized group, with a specialized language and no appreciation for the whole process.⁵⁶

⁵⁵ Burton and Moran, *Future Focused*, 30–70.

⁵⁶ Dan Dimancescu, *The Seamless Enterprise: Making Cross Functional Management Work* (Essex Junction VT: Oliver Wright Publications, 1992), 4.

a. Definition of Cross Functions

Dimancescu uses the cross function definition used by the Japan Union of Scientists and Engineers (JUSE) in 1988. They define cross function as: "a management process designed to encourage and support interdepartmental communication and cooperation throughout a company—as opposed to command and control through narrow departments or divisions. The purpose is to attain such company-wide targets as quality, cost, and delivery of products and services by optimizing the sharing of work." Dimancescu defines the role of cross-functional management as addressing problems associated with sequential hand-offs and chimney like structures by creating a new category of functions that threads across traditional departmental boundaries.⁵⁷ The concept of cross function adds a dimension to TQM that links divisional and departmental activities through horizontal communication.⁵⁸

b. Cross Function Team Composition

According to Dimancescu, the temptation of traditionally-managed companies is to treat problems as a crisis.⁵⁹ Instead the problem is usually a result of a deficiency in the process. Cross-function teams should be composed of people who know and live with a process and have day-to-day responsibilities taken from across an organizations divisions, departments, suppliers, or customers.⁶⁰

C. GOVERNANCE

1. Margot Cairnes. *Boardrooms That Work: A Guide to Board Dynamics*

With the assistance of 100 Chief Financial Officers, (a group known as the Australian Institute of Company Directors) Margot Cairnes wrote an article examining how board dynamics and many issues related to governance as it relates to the success

⁵⁷ Dimancescu, *Seamless Enterprise*, 12.

⁵⁸ Ibid.

⁵⁹ Ibid., 18.

⁶⁰ Ibid., 19.

and failure of a governing body. Many characteristics are discussed that describe the culture of the governing body of a corporation, its Board of Directors (BOD).

A key point discussed in the Cairnes report is the four phases that are used to analyze processes within the board. These processes represent a circular flow of information. Figure 8 outlines how processes are put in place to allow corporate boards of directors to be analyzed.

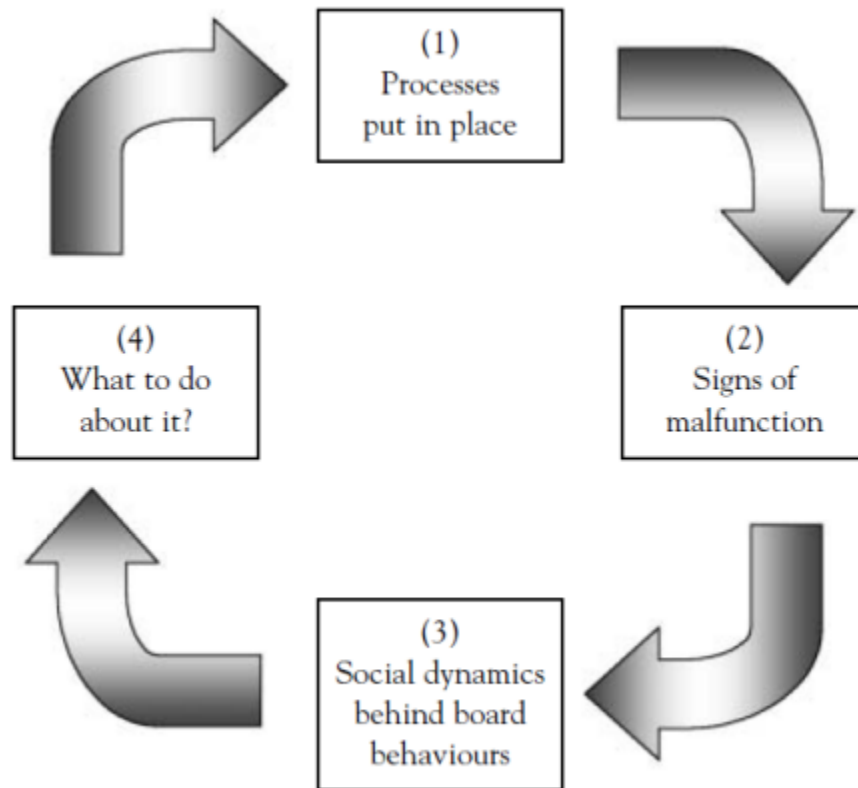

Figure 8. Four processes of good governance. (From: Cairnes, 2003.)

a. Board Processes

The first process recognizes the requirement to implement good processes. However, even the best processes are driven by people, who are in turn driven by personal and group-based factors. Processes only work well when people operate them well.⁶¹ This process describes the general desire of a BOD to want to succeed. In order

⁶¹ Margot Cairnes, *Boardrooms That Work: A Guide to Board Dynamics* (Sydney: Australian Institute of Company Directors, 2003), 8.

for a board to successfully run an organization, the people in charge need to have the capability to implement new policies to keep the company evolving with its competition.

b. Board Malfunctions

The second process notices the early warning signs that indicate these processes are malfunctioning and could cause problems later on.⁶² This process describes a need for the board members to realize when a change or a process is failing. Members have a responsibility to the people that work under them to effectively eliminate processes that are failing.

c. Board Dynamics

The third process understands the human dynamics that create these malfunctions and how these dynamics can change for better decisions.⁶³ This process explores the human element. The Cairnes article discusses several signs attributed with board failure. A selection of these signs are listed and described below:

(1) The dominant personality. The dominate personality intimidates other members of the board room. This specific personality trait is detrimental to fostering an environment that welcomes the open flow of communication. An unruly personality can have a negative impact on the board. “The healthiest way to deal with political dynamics is to bring them to the surface, discuss them, observe them, and deal with them openly.”⁶⁴

(2) Hurried decisions based on inadequate data. Perfect information is expensive and hard to locate. Most decisions made by board members are based on inaccurate information. In the business world policies need to be made quickly, as a rapid change could have drastic financial rewards. A board that bases it decisions on inadequate data is taking a risk.

(3) Serial restructuring and resignations of key individuals.

⁶² Cairnes, *Boardrooms That Work*, 7.

⁶³ Cairnes, *Boardroom*, 11.

⁶⁴ *Ibid.*, 12.

Changing of key leadership positions within any organization can have a negative response in the board room. Members within the organization are often left in the dark as why these people have left the company. Often executives leave an organization to pursue other interests. These interests can sometimes conflict with the strategic goals of the organization. This change in leadership is cause for malfunction.

(4) Do as I say, not as I do. It is important for leaders within an organization to comply with the values and rules of the company.⁶⁵ Leaders within the board that do not act in accordance with these characteristics do not represent the best people within an organization. These leaders do not promote the best values of the organization.

(5) The cover-up. Public opinion is a large factor in any organization. Companies lose credibility when they try cover-up errors made by either personnel in the company, or poor decisions made from within the BOD. Ethical concerns are not always the primary factor in decisions made by a board, and sometimes the results have a negative impact.

(6) Interfering with the information flow. Interfering with the flow of information can have a negative impact on board performance primarily due with discussions and debates created in conjunction with the problem instead of problem solution. The Cairnes article discusses several tactics that can be of concern to a BOD. The majority if these concerns addresses overflowing BOD members with an excessive amount of information, and not providing adequate time for a review prior to making a decision.

(7) Favoring particular interests. This area describes decisions made in manipulation and interpretation of federal laws and guidelines that represent the best interests of the company. The article points out that the failure of many companies has been attributed to poor accounting practices and an overall lack of integrity.

⁶⁵ Cairnes, *Boardrooms That Work*, 13.

d. Board Culture

The fourth process puts things right, ensuring that the environment is optimal for continuing good governance. This may require modifying processes to incorporate lessons learned during the first three processes.⁶⁶ Her article provides insight into human behavior and explores some of the reasons attributed to poor governance especially when used to analyze a BOD. She discusses personal interests, greed, and lust for power as possible reasons that members of boards fail in their responsibilities to the organization. It also discusses the steps to build a healthy culture within the BOD.

- Including building a healthy, functioning culture as an ongoing board agenda item, even if some directors think that the board culture needs no improvement. The more directors who think there is nothing to improve, the more likely it is that the board culture needs a review.
- Assessing the current board culture and your progress over time, seeking outside assistance as necessary
- Working out what kind of board culture you want⁶⁷

2. Phillip J. Streatfield: *The Paradox of Control in Organizations*

Philip Streatfield uses his own experiences and practices as a manager to address the central question of organizations: who is in control? Streatfield suggests that the idea of a manager being in control in an organization is a paradox. The main argument is to falsify the traditional views of management: an objective observer who is outside the process, reduces unpredictability and misuse of resources by correcting deviations, and deliberately designs the process from which the organization operates.

a. Mainstream Understanding of Control

The mainstream understanding requires the manager's position to be in control of the organization and eliminate everything not in control. According to

⁶⁶ Cairnes, *Boardroom*, 27–28.

⁶⁷ Cairnes, *Boardroom*, 27–28.

Streatfield, this understanding is more problematic than usually assumed because managers are both in control and not in control at the same time.⁶⁸ As an organization moves into the future, the essential function of management is to control that movement by observing the system, analyzing it, designing it, and acting upon leverage points so that the movement into the future realizes or unfolds a state that has already been devised in the past or present.⁶⁹ Along the way, deviations from the path are detected and corrected so movement stays on the path designed by managers. The goal and the path are largely known and formed intently by management so the organizations movement is predictable, stable, regular and certain.⁷⁰

The issue that Streatfield has with the mainstream understanding of control is how little attention it gives to the present. It relies on patterns experienced in the past and the projection into the future, which means that the meaning of what people do is located in the past, or identified in the vision of the future.⁷¹ Streatfield proposes a perspective called the complex responsive process perspective which avoids collapsing thought to either in control or not in control and allows managers to embrace the paradox within which they must work.

b. Complex Responsive Process

The present is not a point through which an organization passes on its way from the past toward the future. Instead it is a living process of communication in which the meaning of the gesture past is changed in the future response.⁷² The perspective of complex responsive processes shows that it is stable and self-organizing patterns of meaning that maintain a sense of order and control as managers go about daily activities. An important aspect of this perspective is how key the role of conversation and communicative interaction between managers and members of the organization is in

⁶⁸ Philip J Streatfield, *The Paradox of Control in Organizations* (London: Routledge, 2001), 125.

⁶⁹ *Ibid.*, 126.

⁷⁰ Streatfield, *Paradox*, 127.

⁷¹ *Ibid.*

⁷² *Ibid.*, 130.

developing the organizations future. Streatfield suggests that the future of an organization is created through the communicative interaction of gestures and responses made by managers and other members of an organization in the present situation.⁷³

According to Streatfield, since it is impossible for any participant in an organization to be fully in control, the essential function of managers cannot be to simply control the movement of the organization. The movement of an organization is stable and unstable, regular and irregular, predictable and unpredictable all at the same time.⁷⁴ Transformative movement of an organization can only be accomplished with a diversity of human participation and conformity, consensus and conflict, understanding and misunderstanding all occurring simultaneously.⁷⁵ A purely hierarchical structure seeks to remove the negative variables not in control instead of embracing them as part of the process.

Another important aspect that organizations must face and is inherent in the reality of management is anxiety. Streatfield defines anxiety as a general state of unease for which no causal object can be identified. Anxiety relates to a sense of something being amiss with the unconscious sensing of the potential loss of meaning.⁷⁶ For management to lead an organization successfully, managers must have the capacity to continually participate with members of the organization in which new meaning and direction potentially emerges. Through this understanding of control, management can effectively transform the identity of the organization and its participants and lead the organization into the future.⁷⁷

c. Management Participation in the Construction of Meaning

Streatfield argues that the key management ability is not one of being in control; instead it is the ability to participate creatively in the formation of transient

⁷³ Streatfield, *Paradox of Control*, 130.

⁷⁴ *Ibid.*, 130.

⁷⁵ Streatfield, *Paradox of Control*, 132.

⁷⁶ *Ibid.*, 126.

⁷⁷ *Ibid.*, 133.

meaning.⁷⁸ Establishment of this meaning will allow the participants to live with the anxiety that is natural in a changing environment. Construction of meaning will also create a sense of order, coherence, pattern and control.⁷⁹ The key distinction between mainstream thinking of management and what Streatfield proposes is the participative construction of the organization's meaning. Mainstream thinking focuses attention on management intention and system control mechanisms to reduce variables that cannot be controlled. The focus of complex responsive processes focuses attention on the wider self-organizing dynamic in which managers participate and collaborate through all levels of the organization.⁸⁰

D. SUMMARY

This literature review has discussed ideas and concepts presented by their authors that will build a framework on which to discuss concepts related to enterprise management throughout the remaining chapters. The first was Labovitz and Rosansky's argument of the importance of organizational alignment. For an organization to stay centered through change, it must be vertically and horizontally aligned. They also focus on the organizations main thing which should be used to generate a culture of unity with capable leadership at all levels of the organization. Burton and Moran build on this concept of alignment as they discussed their model for the future-focused organization. They argue the necessity of three levels of management for an organization to set and accomplish long-term objectives. They place a heavy emphasis on the lateral or cross-functional level of management which Dimancescu further elaborates on. Burton and Moran also discussed responsibilities and behavioral functions required by an organizations leadership. Cairnes presents the social dynamic that is present in organizational governance and how it must be managed for a governing body to employ

⁷⁸ Streatfield, *Paradox of Control*, 136.

⁷⁹ *Ibid.*, 136.

⁸⁰ Streatfield, *The Paradox of Control*, 136.

good governance. Finally, Streatfield argues the paradox of control and the importance of management's participative and communicative role in an organizations movement and transformation into the future.

These authors have introduced concepts of organization, governance, and leadership as applied by corporate organizations. Their tools, models, and ideas have appropriate considerations as it pertains to SWE. These theories and proposed practices are relevant to the analysis of SWE since they give a base on which the implementation of the enterprise concept in SWE can be examined. Enterprise success is largely determined by how well an organization is aligned, managed across boundaries and layers, governed, and led. These elements have become present in SWE as it has developed since 2005. Since its inception, SWE has attempted to align and synchronize its critical elements, remove barriers between layers of the surface community through cross-functional teams, and create a governing body of leaders that can manage the direction and prioritize the objectives of the SWE. This literature review has explained the relevance of these concepts as they pertain to enterprise management. The remainder of the project will examine how these concepts have been implemented in Surface Warfare Enterprise.

THIS PAGE INTENTIONALLY LEFT BLANK

III. SURFACE WARFARE ENTERPRISE

The SWE provides us tools to improve processes, execute streamlined business practices and gain effectiveness throughout our Navy to produce warfighting effectiveness.

VADM D.C. Curtis, CNSF
SWE 2010 Strategic Plan

A. INTRODUCTION

This chapter presents the Surface Warfare Enterprise from its early initiatives and inception in 2005 to the present. In order to better understand the SWE effort, this chapter discusses the SWE organization and processes in more detail than broadly presented in Chapter I. This chapter first defines the SWE. This definition and understanding is necessary before presenting how it has been developed. It then attempts to capture the history of SWE by discussing the major initiatives that preceded SWE, how enterprise management was initially implemented, and how it has transformed since its development. The chapter will provide the data necessary to answer the primary research question by discussing SWEs organization, governance, and leadership in detail. Lastly, it will identify examples related to SWE resource allocation effects, but not enough data will be presented to fully answer the supporting research questions.

Findings obtained from a range of sources are presented throughout the chapter. These findings were determined from data that was gathered from internal SWE training briefs, documents, and formal interviews to capture the history of SWE, and insights into how SWE works as an organization. Most of the data gathered from formal interviews verified what was previously researched in archival documents; however, the interviews provided more detail and explanation of the activities and inter-relationships of the SWE organization.

B. SWE DEFINED

SWE is an organizational construct that uses an enterprise approach to align numerous organizations within the surface community in order to function as a single entity.⁸¹ Its goal is to supply the right force of surface warships, at the right level of readiness, and at the right time.⁸² As the surface force supplier to the FRE, the SWE provides warships that are ready for tasking by USFF, Commander Pacific Fleet (CPF), and meet the requests for forces (RFF) by Combatant Commanders.⁸³ The enterprise addresses manning, maintenance, and material concerns related to surface warships, amphibious landing crafts (LCU, LCAC) and their crews, but does not deal with aircraft carriers, submarine tenders, submarine floating dry docks, and riverine warfare craft.⁸⁴ SWE is not a command. Instead, it is an organizational instrument that provides the many organizations in the surface community a forum to address and solve issues that otherwise could not be effectively done without cross-organization collaboration. From this forum, SWE is able to set surface navy priorities and influence the allocation of resources.

C. IMPLEMENTATION OF ENTERPRISE MANAGEMENT

1. Beginning Initiatives

In an effort to initiate an enterprise management system in 2002, several Navy-wide initiatives were being implemented. Surface programs included goals and strategy to effect rapid changes in the way the surface navy was conducting business. Although some of these programs had an immediate and measurable outcome, many of the new initiatives would take a few years for changes to be realized. The initial programs involved surface ship maintenance and training.

⁸¹ Commander, Naval Surface Forces. *SWE 101* (San Diego CA, 2010), 7.

⁸² *Ibid.*, 11–12.

⁸³ *Ibid.*, 19.

⁸⁴ *Ibid.*, 19.

a. SHIPMAIN

SHIPMAIN began in November of 2002 with a primary mission to improve the maintenance and modernization processes for surface vessels. SHIPMAIN was responsible with achieving the following objectives:

- (1) Accomplish right work, right time, right cost.
- (2) Collaborate across enterprise stakeholders.
- (3) Work closely with regional maintenance integration.
- (4) Use proven commercial process improvement methods.
- (5) Deliver a ready fleet at a lower cost.⁸⁵

SHIPMAIN was initiated due to the readiness crisis that navy aviation began experiencing in the late 1990s.⁸⁶ In response to this decreasing readiness, aviation leaders began to work with the Thomas Group and implement process improvement initiatives that were used to increase production, efficiencies, and ROI. Thomas Group is a management consulting firm leading companies on issues of strategy, change, organization, operations management, and process improvement. ADM Clark, CNO, began to pressure the surface force about its maintenance requirements and budgets, so VADM Tim LaFleur, CNSF, hired the Thomas Group in late 2002 to help examine and reduce the cost of ship maintenance.⁸⁷ Surface leaders, along with the Thomas Group, established a Process Improvement Team (PIT) as the supervisory council to observe and improve the SHIPMAIN policies and procedures. This team included stakeholders and key leaders throughout the surface navy. Figure 9 is a representation of the PIT organization:

⁸⁵ Naval Sea Systems Command. *SHIPMAIN Overview* (Washington DC 2006), 2.

⁸⁶ Sam Perkins, *Navy Enterprise Transformation : Working for the Greater Good* (Washington DC: Babson Executive, 2007), 3.

⁸⁷ *Ibid.*, 13.

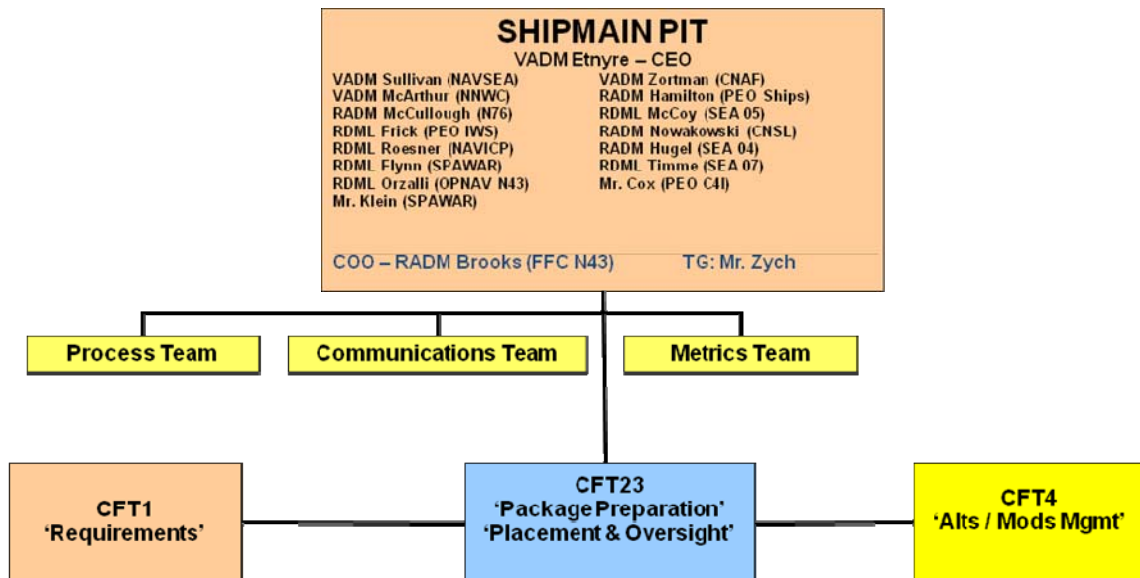

Figure 9. SHIPMAIN PIT Structure. (From: NAVSEA SHIPMAIN Overview Presentation, February 2006)

The PIT met monthly and face-to-face every quarter. It was divided into three cross functional teams (CFT) shown in the figure. Each team worked on its portion of the maintenance process in parallel, while the supporting Process Team ensured they stayed aligned. PIT CFTs were led by two Flags, with O-6 level Action Officers, and over fifteen members representing multiple commands. The CFTs would meet weekly in order to get things done fast, and remove organization barriers identified in the process.⁸⁸

Prior to taking over as CNSF in March 2005, VADM Terry Etnyre led the SHIPMAIN Requirements CFT.⁸⁹ This position exposed VADM Etnyre to enterprise practices and introduced him to the benefits of having a cohesive group of diverse people who were able to work together across stovepipe boundaries to align around common goals.⁹⁰

Although this program was created prior to the development of SWE, many of the cost cutting measures are being realized today. In early 2006, SHIPMAIN objectives

⁸⁸ Naval Sea Systems Command, *SHIPMAIN*, 5.

⁸⁹ Perkins, *Navy Enterprise*, 12.

⁹⁰ *Ibid.*, 13.

were updated to reflect changes in current leadership philosophies, and policy requirements. The following reflect the updated SHIPMAIN objectives:

- Install a common planning process for surface ship and carrier maintenance, and modernization.
- Increase the efficiency of the process and deliver quantifiable savings without compromising its effectiveness.
- Install a disciplined management process with objective measurements.
- Institutionalize the process and a continuous improvement method.⁹¹

The ultimate goal of SHIPMAIN was to maintain a consistent approach to shipboard maintenance. This would create a steady stream of maintenance practices throughout the fleet. A sailor attached to a ship on the west coast would notice no difference in maintenance policies and procedures if he transferred to the east coast.

In 2006, SHIPMAIN processes were expecting to show a positive effect on recovering dollars that can be reallocated to other programs. Figure 10 demonstrates the funds that were expected to become available:

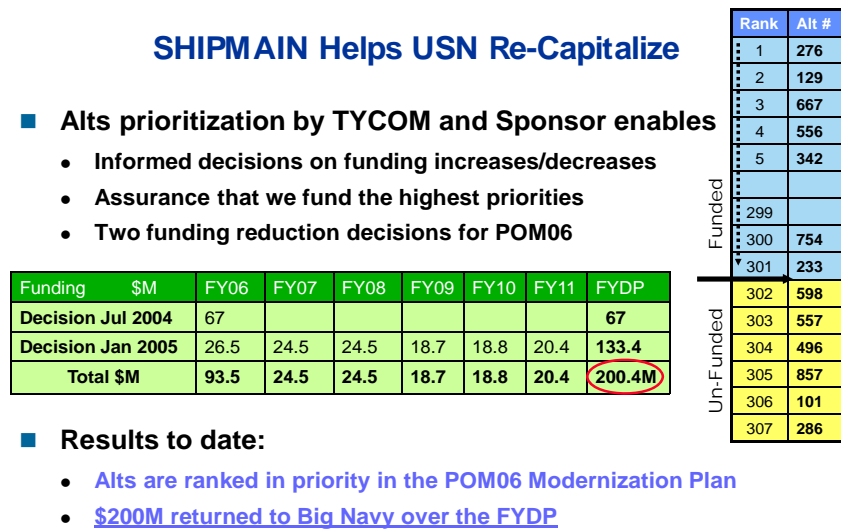

Figure 10. SHIPMAIN Helps USN Re-Capitalize. (From: NAVSEA SHIPMAIN Overview Presentation, February 2006)

⁹¹ Perkins, *Navy Enterprise*, 3.

b. SHIPTRAIN

SHIPTRAIN is a revolutionary process improvement that provides the measurement tool to sustain unit proficiency at the most effective and efficient level of operational readiness

VADM Terry Etnyre, CNSF
14 February 2006

The CNO's Guidance for 2004 directed a zero-based review of the Surface Force Inter-deployment Training Cycle (IDTC).⁹² This review spawned a new training process called SHIPTRAIN, which began in March 2004 and was implemented fleet-wide in 2006. This training plan took the proven methods of the IDTC and adapted them to fit the new readiness requirements of the Fleet Response Plan (FRP).⁹³ The FRP was adopted in 2003 in response to a need for a readiness approach that would allow a high number of assets to deploy more quickly. Under this plan, ships returning from deployment would almost immediately enter the basic training phase, which would be conducted before and after a ship's depot level maintenance phase.⁹⁴ SHIPTRAIN was developed in order for commanders to accelerate the surface training process. SHIPTRAIN's primary goal was to reduce the time required to assess, train, and certify a ship and her crew from sixteen weeks down to four weeks.⁹⁵ Several programs were developed to assist commanders in this process:

(1) Unit Level Training Assessment (ULTRA) inspections which are scheduled every two years followed by another ULTRA assessment every six months. The purpose of ULTRA is to validate the ship's ability to self assess and train.⁹⁶

(2) Training and Operational Readiness Information Services, Training Figure of Merit (TORIS/TFOM). TORIS/TFOM gives commanding

⁹² Paul Taylor, *SHIPTRAIN Revolutionizes Surface Force Training*, (San Diego: Commander, Naval Surface Forces, 2006), 1.

⁹³ Taylor, *SHIPTRAIN*, 1.

⁹⁴ Roland Yardley et al., *Impacts of the Fleet Response Plan on Surface Combatant Maintenance*, (Washington DC: RAND, 2006), 23.

⁹⁵ Taylor, *SHIPTRAIN*, 1.

⁹⁶ *Ibid.*, 1.

officers the ability to track their ship's combat readiness and then allocate training resources appropriately to maintain.⁹⁷ The system works on a simple red/yellow/green system similar to a stoplight. Green indicates a warfare training area is within readiness standards, yellow indicates readiness is getting close to reaching its periodicity, while red indicates a warfare training area is out of current readiness standards.

2. SWE Launch

VADM Etnyre took over as CNSF in March 2005 with a positive outlook on the potential effects of enterprise practices. Soon after assuming command, VADM Etnyre put enterprise behavior to work by establishing Littoral Combat Ship (LCS) oversight. He realized that the stovepipe command structure was not aligned with the requirements demanded by the LCS program.⁹⁸ LCS oversight consisted of an oversight board with two cross-functional teams in charge of coordinating stakeholders, and developing the new processes required to launch a very different class of ships.⁹⁹

VADM Etnyre's next move was to spread these emergent enterprise practices throughout the surface forces. The SWE was formally established in November 2005 when the first Surface Board of Directors and three process teams met in Washington D.C. and conducted the first board meeting.¹⁰⁰ The intent of the enterprise model was to use enterprise behavior as a tool to understand processes, and align the organization to execute those processes in a way that allows it to be monitored using certain metrics.¹⁰¹ With SWE, VADM Etnyre was careful not simply re-apply the TQM initiatives that saw minimal results in the 1990s.¹⁰² The impact he liked most from SHIPMAIN and wanted applied to SWE was the effect process mapping and information transparency had on

⁹⁷ Taylor, *SHIPTRAIN*, 1.

⁹⁸ Perkins, *Navy Enterprise*, 13.

⁹⁹ *Ibid.*, 13.

¹⁰⁰ Commander, Naval Surface Forces. *Surface Warfare Enterprise Charter*, (San Diego: 2010), 6.

¹⁰¹ Perkins, *Navy Enterprise*, 13–14

¹⁰² *Ibid.*, 13–14

enabling leaders outside his direct command to understand the importance of their activities in a larger process and expand their sense of ownership in the role they have in producing the desired output.¹⁰³

SWEs development can be attributed to factors both internal and external to the surface navy, which are listed below:

- Process improvement programs and initiatives of navy aviation.
- Large gaps between desired and actual funding levels.
- Inefficient and ineffective consumption of resources.
- Sea Enterprise initiative from CNO ADM Clarks Sea Power 21 concept.
- Pressure from the CNO to answer maintenance and cost related questions.
- Success of the PIT in the SHIPMAIN initiative.
- The formal establishment of the NAE in 2004.
- The experiences of the Thomas Group.
- A realized need for new organizational and cultural behavior.¹⁰⁴

By the end of 2006, SWE initiatives were already projecting to achieve tangible savings. Figure 11 details the projected savings determined in October 2006:

Initiative	Projected Savings	Projected Avoidance
DDG Cost Reduction		\$267.1M
Geographic Detailing		\$2M
eRMS		\$2.0 – \$2.5M
NEC Mismatch Reduction		\$10M
Diesel Improvement Program	\$50M/year	
SHIPMAIN	\$690.4M	
Customer Relations Mgmt	\$25M	
METCal Mgmt System	\$10M	
Distance Support/Tech Assist	\$5M	
Performance Based Logistics	\$300M	
FY06 CNSL Fuel Under burn	\$13M	
FDNF NEC TADTAR	\$.25M	
Total	\$1,093.65M	\$286.1M

Figure 11. Total Projected SWE Savings and Cost Avoidance. (From: Perkins, 2007).

¹⁰³ Perkins, *Navy Enterprise*, 7.

¹⁰⁴ *Ibid.*, 1–13.

3. NAE Influence

Much of SWEs initial implementation of enterprise practices was influenced by the NAE. In 1998, aviation leaders began working with the Thomas Group as its production consultant to help fix the costly training cycle of pilots through the Naval Aviation Production Process Improvement (NAPPI) program.¹⁰⁵ The first agreement that Thomas Group made with senior aviation leadership was that they must change the way they did business.¹⁰⁶ This relationship and Thomas Group's strategic way of thinking ultimately led to the development of the NAE in 2004.

The NAE organization is modeled after a corporate structure and is diagramed in Figure 12. It is comprised of a Board of Directors (BOD) with a six member executive steering committee composed of Commander, Naval Air Forces (CNAF) as the Chief Executive Officer (CEO); Commander, Naval Air Systems Command (NAVAIR) as the Chief Operations Officer (COO); Commander, Naval Air Forces Atlantic (CNAL) as the Enterprise Readiness Officer; Total Force Readiness Officer (AIR 1.0 NAVAIR) for policy and personnel; a Chief Financial Officer (CFO)(AIR 6.8, NAVAIR) and OPNAV N88 for acquisition and procurement.¹⁰⁷ This organizational structure is similar to the SHIPMAIN PIT, which was also influenced by the Thomas Group, and adopted by SWE. A key relationship in this model is between CNAF and NAVAIR. CNAF and NAVAIR work very closely together, a similar relationship that would be developed with CNSF and NAVSEA.

¹⁰⁵ Perkins, *Navy Enterprise*, 5.

¹⁰⁶ *Ibid.*, 5.

¹⁰⁷ Robert J. Williams, *Evaluation of Naval Aviation Enterprise Airspeed's Generation of Measurable Cost Savings and Reinvestment for Recapitalization of the Future Navy and Marine Corps*, (Master's thesis: Naval Postgraduate School, 2007), 40.

Naval Aviation Enterprise Structure

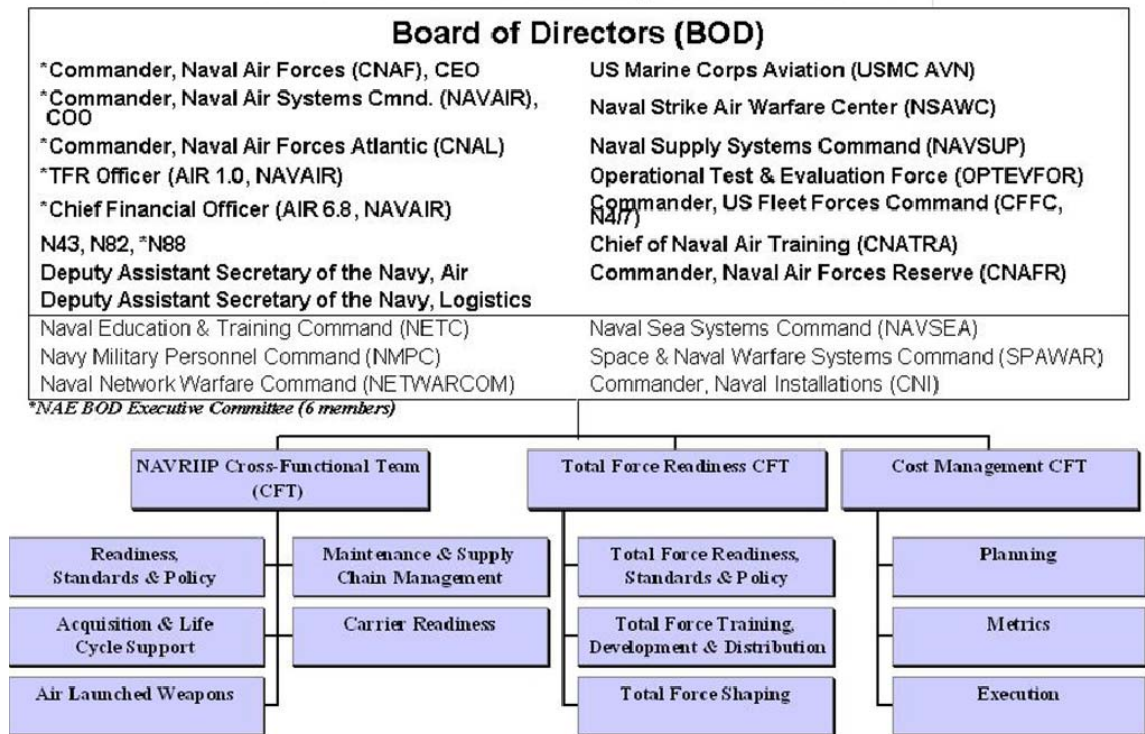

Figure 12. Naval Aviation Enterprise Structure. (From: Robert Williams, NPS Thesis, June 2007)

4. SWE Development November 2005–March 2008

After SWEs initial meeting in November 2005, the first task was to lay the groundwork for how it was going to operate. The first half of 2006 was devoted to collecting baseline data and developing a strategic plan that clearly identified what the desired effects would be, and the objectives required to meet them.¹⁰⁸ SWE was established as a strategic level organization with the primary objective of providing warships ready for tasking. Strategic objectives were developed and laid out in the first SWE Strategic Plan. These six strategic objectives drive enterprise efforts within the organization. The SWE objectives are aimed at making smart decisions that will have

¹⁰⁸ Perkins, *Navy Enterprise*, 13.

long term impact and sustain current readiness while managing a fiscally challenged environment.¹⁰⁹ Below is a list of the objectives which are still in place today.

- Produce prescribed levels of warfighting readiness based on USFF defined demand signals.
- Deliver and retain a diverse mix of officers, enlisted, civilians and contractors with the right competencies and proficiencies, in the right place, at the right time, for the right value – balancing cost and readiness while adhering to SWE values.
- Mature the enterprise financial management process that enables the SWE to allocate and manage more effectively its financial resources to support current readiness and future capabilities.
- Implement standardized cost management processes and financial metrics to drive increased productivity (cost/readiness).
- Reduce total ownership costs (TOC) across the SWE.
- Improve enterprise maturity and execution through the development of relationships with SWE partners, in particular providers and enablers.¹¹⁰

The second half of 2006 was largely devoted to establishing the Class Squadrons (CLASSRON). VADM Etnyre established eight CLASSRONs that represented and supported ships of the same class. These organizational entities were to focus efforts across the entire enterprise and be the interface between the SWE and the fleet.¹¹¹

CLASSRONs are functional commands that represent each class of ship and are led by Commander Naval Surface Forces Atlantic (SURFLANT) who also serves as the SWE Chief Readiness Officer (CRO). CLASSRONs represent each class of ship in SWE and identify readiness issues related to a specific class. The ship's CLASSRON will then work with SWE cross functional teams to develop and implement a solution that ensures maximum readiness. As stated in the SWE 2008 Strategic Plan, the three goals of the CLASSRONs are:

¹⁰⁹ Commander, Naval Surface Forces, *SWE 2010 Strategic Plan*, (San Diego: 2008), 6–14.

¹¹⁰ Commander, Naval Surface Forces, *SWE 2010 Strategic Plan*, 6–14.

¹¹¹ Perkins, *Navy Enterprise*, 12.

- The CLASSRON will leverage cross-functional capability through the SHIPMAIN and SHIPTRAIN program processes
- The expected outcome is a cadre of subject matter experts organized by classes of ships that will provide greater effectiveness across the SWE.
- Imperative to the success of CLASSRONS is to ensure that manning matches the required functions they will be performing. As their functions increase or change, it will be necessary for their manning to adjust accordingly. This will be done either by increasing in size, decreasing in size, leveraging provider/enabler commands or any other manner deemed appropriate to match functions with tasks.¹¹²

CLASSRONS are geographically located in the following fleet concentration areas: San Diego, CA (LCS, LSD, LPD-17, CG, and MCM) Norfolk, VA (LCAC/LCU/LCM, DDG, PC, LHA/LHD/LPD, and FFG). CLASSRONS are responsible to CNSF for the following:

- Report to Deputy Commander Naval Surface Forces (DCNSF)/CRO and work's with both CNSF/CNSL Type Commander (TYCOM) and Immediate Superior in Command (ISIC) to support their ship class
- Identify root cause issues which degrade readiness and work with supporting organizations to develop solutions and track implementation and progress
- Resource prioritization
- TYCOM Agent across manning, training and equipment
- Process improvement and trend analysis¹¹³

Figure 13 shows the CLASSRON relationship between the enterprise and the fleet.

¹¹² CNSF, *SWE Strategic Plan*, 8.

¹¹³ CNSF, *SWE 101*, 19.

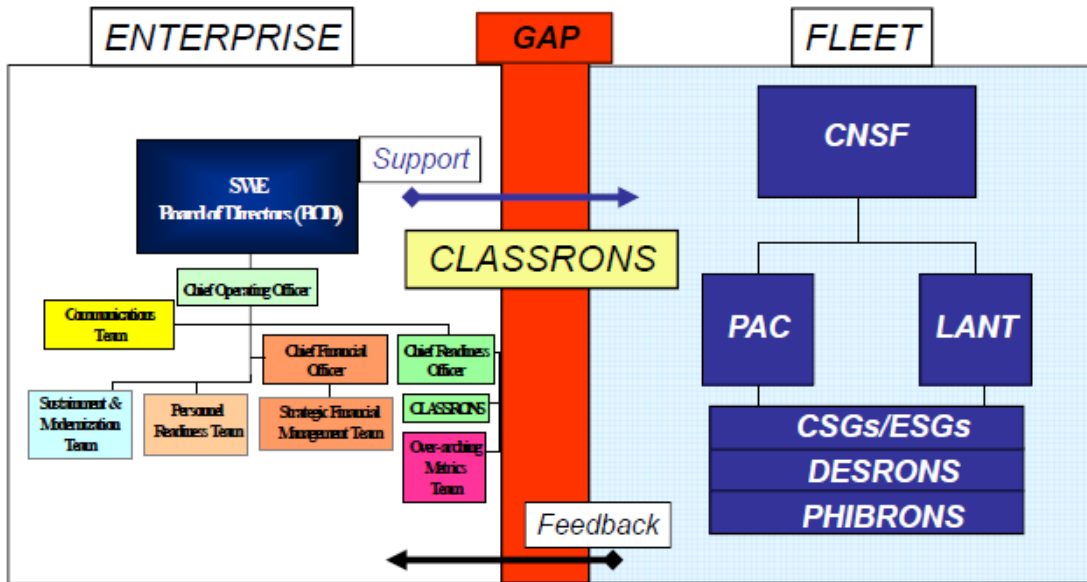

Figure 13. CLASSRON Enterprise and Fleet Relationship. (From: Joint Industry Navy Improvements Initiative Meeting Presentation, 2007)

In the beginning stages, emphasis was first put on the SWE as a business model with business terminology applied to SWE activities. This is illustrated by the labeling of SWE positions were given: Chief Executive Officer (CEO), Chief Operating Officer (COO), Chief Financial Officer (CFO), and the Surface Board was also first labeled the Board of Directors.¹¹⁴ This setup mirrored the NAE and represented Thomas Group’s corporate as for-profit business way of thinking. It also associated the SWE organization with an attempt to run the surface navy like a business. This new business model and way of thinking spawned confusion as to whether or not effects on ship readiness could be attributed to Type Commander decisions or the Enterprise.¹¹⁵

5. SWE Development March 2008–Current

In March 2008, VADM D.C. Curtis took over as CNSF and leader of SWE. His previous tenure as SURFLANT and Chief Readiness Officer (CRO) to the SWE gave him insight to how the enterprise was operating. In this same month, SWE also saw a change in strategic consultants. Booz Allen Hamilton took over from the Thomas Group

¹¹⁴ Bill Smith, interview held in San Diego, 14 September, 2010.

¹¹⁵ Ibid

as the primary SWE consultants. This transition took place without any turnover and brought a significant change in the working methodologies of the SWE.¹¹⁶ The Thomas Group provided strategic support and was collocated with SWE personnel three days a week, operating primarily from Texas.¹¹⁷ Booz Allen is collocated with the SWE five days a week in all major regions: Norfolk, VA; San Diego, CA; Mayport, FL; and Washington, D.C. Booz Allen gives SWE the same strategic support as Thomas Group did, but has also taken a much more tactical role by assisting the government employees in the execution of the suggestions they recommend.¹¹⁸

Change in the SWE commander and strategic consultants marked a change in SWE direction. In June 2008, the SWE Executive Committee (EXCOMM), Surface Board, and Senior Executive Service (SES) members held a strategic planning session. During this meeting, the 2006 Strategic Plan was updated with no major objective changes; however, some underlying initiatives for each strategic objective were changed.¹¹⁹ The SWE charter was also developed which assigned major roles and responsibilities and battle rhythm of the organization.¹²⁰

With new direction set, VADM Curtis began to focus on changing the tone of the enterprise.¹²¹ Instead of being focused on business practices and efficiencies, he wanted the focus to be cooperation and collaboration of people throughout the enterprise.¹²² Since 2008, VADM Curtis has taken the SWE from a focus on running like a business, to the use of enterprise behavior in direct support of the warfighter.¹²³ By not thinking of

¹¹⁶ Smith interview.

¹¹⁷ Ibid.

¹¹⁸ Ibid.

¹¹⁹ Ibid.

¹²⁰ Ibid.

¹²¹ D.C. Curtis, interview held in San Diego, 15 September, 2010.

¹²² Ibid.

¹²³ Ibid.

SWE as a business, enterprise practices have now become a behavior within a warfighting organization in order to provide warships ready for tasking, and maintain a holistic view of the force.¹²⁴

In October 2010, CLASSRON functions officially transitioned to N code Type Commander responsibilities. This restructuring has taken place to ensure clearer lines of accountability since CLASSRONs were developed without direct decision making authority. The functionality that the CLASSRONs provided are important to SWEs ability to recognize and act on trending problems within a class of ship, so it was important to retain the benefits CLASSRONs provided to the SWE.¹²⁵ Appendix A presents a timeline that captures the SWE history and progression of enterprise practices.

6. Enterprise Maturity Model

SWE's sixth and last strategic objective is focused on improving SWEs maturity as an enterprise organization. One of the tools the Thomas Group brought to the SWE was the Enterprise Maturity Model (EMM).¹²⁶ The EMM was described by the Thomas Group as an enterprise analysis, governance, and audit tool.¹²⁷ It was adopted by the SWE in 2006 and tailored to fit the surface navy goals with the intent of jumpstarting SWE enterprise efforts.¹²⁸ The EMM can be compared to the Capability Maturity Model Integration (CMMI), which was developed by the Software Engineering Institute at Carnegie Mellon and used by more than five thousand organizations worldwide.¹²⁹ The SWE EMM is broken into two parts with six categories each. For each category, there are associated columns that define the level; the higher the level, the greater the competency for that specific category. Levels one to two typically represent the foundational elements of a category, which are the basic tools and structures needed in

¹²⁴ D.C. Curtis, interview.

¹²⁵ Smith interview.

¹²⁶ Ibid.

¹²⁷ Ibid.

¹²⁸ Ibid.

¹²⁹ Ibid.

order to be successful at the higher levels, levels three to five.¹³⁰ The first part focuses on enterprise management characteristics and how an enterprise should be governed and led. Figure 14 shows these categories with their level five goals, and examples.

	Goals	Example
1 Change Management Organization	• Enterprise leadership puts the organizational constructs in place to support change	• Cross Functional Teams (CFTs) drive the Enterprise leadership process
2 Governance	• Management processes, roles, plans and measures are cross-Enterprise in scope	• The Leadership Team drives execution of an integrated planning process
3 Alignment	• Enterprise plans, goals, metrics, and processes are aligned and support Enterprise objectives	• All business and support process inputs and outputs are aligned
4 Mgmt. Process, Scope & Boundaries	• Enterprise Management has the authority and responsibility needed to implement Enterprise-level change	• Enterprise manages all key leveraged value stream processes
5 Problem Barrier Resolution	• The Enterprise is effective at removing barriers to change and effective implementation	• A clear escalation process exists to resolve disputes between teams
6 Strategy & Planning	• The Enterprise has a clear integrated vision, mission, and plan	• Enterprise strategic process cascades to all subordinate domains

Figure 14. EMM Management Rows (From: Commander, Naval Surface Forces. EMM Presentation, 2008)

The second part of the EMM describes the execution and results an enterprise needs to practice. Figure 15 shows these categories.

¹³⁰ D.C. Curtis, interview.

	Goals	Example
7 Process Driven	<ul style="list-style-type: none"> Enterprise processes are well defined and managed across organizational boundaries 	<ul style="list-style-type: none"> All leveraged business processes have well-defined inputs, outputs, timing, cost and quality
8 Metrics – Drivers and Results	<ul style="list-style-type: none"> The Enterprise uses metrics effectively to drive behavior and results across the Enterprise 	<ul style="list-style-type: none"> There is a single Enterprise driven set of metrics
9 Cost Management	<ul style="list-style-type: none"> Financial models, processes, and definitions are consistent across the Enterprise and effectively support decisions 	<ul style="list-style-type: none"> A Financial Planning Process is used to start driving productivity improvements
10 Improvement Process	<ul style="list-style-type: none"> The Enterprise has the tools, understanding and culture to support continuous change 	<ul style="list-style-type: none"> A formal “lessons learned” process is in place and used to drive improvement
11 Tools & Methodology	<ul style="list-style-type: none"> The Enterprise shares common tools & methodologies to support Enterprise objectives 	<ul style="list-style-type: none"> Training processes exist to provide new staff with an understanding of shared tools/method.
12 Results Evidenced	<ul style="list-style-type: none"> The Enterprise sets, tracks, and regularly achieves its goals 	<ul style="list-style-type: none"> The Enterprise and all teams regularly achieve productivity improvements

Figure 15. EMM Execution and Results Rows. (From: Commander, Naval Surface Forces. EMM Presentation, 2008)

This model has been the tool used by the SWE since its early stages to assess the SWEs progress towards becoming a more mature enterprise. This model is presented at surface board meetings to give SWE leaders a better idea of where the organization stands, and how it is maturing as an enterprise. These figures are only a snapshot of the entire twelve by five matrix. The entire SWE EMM can be viewed in Appendix B.¹³¹

D. ORGANIZATION AND ALIGNMENT

Figure 16 shows the current SWE organizational structure. It is comprised of a surface board with a ten member senior executive committee (EXCOMM). The surface board is supported by five CFTs; titled Future Capabilities Team (FCT), Future Readiness Team (FRT), Personnel Readiness Team (PRT), Strategic Financial Management Team (SFMT), and Current Readiness Team (CRT). Each team is chaired

¹³¹ CNSF SWE 101, 13.

by a member of the Surface Board. SWE is headed by CNSF with the support of the EXCOMM, Surface Board, and SWE Deputy Commander. Although still very similar to the SHIPMAIN and NAE structure, it has expanded since 2005 by adding two additional future focused CFTs, supporting teams, and additional surface board members.

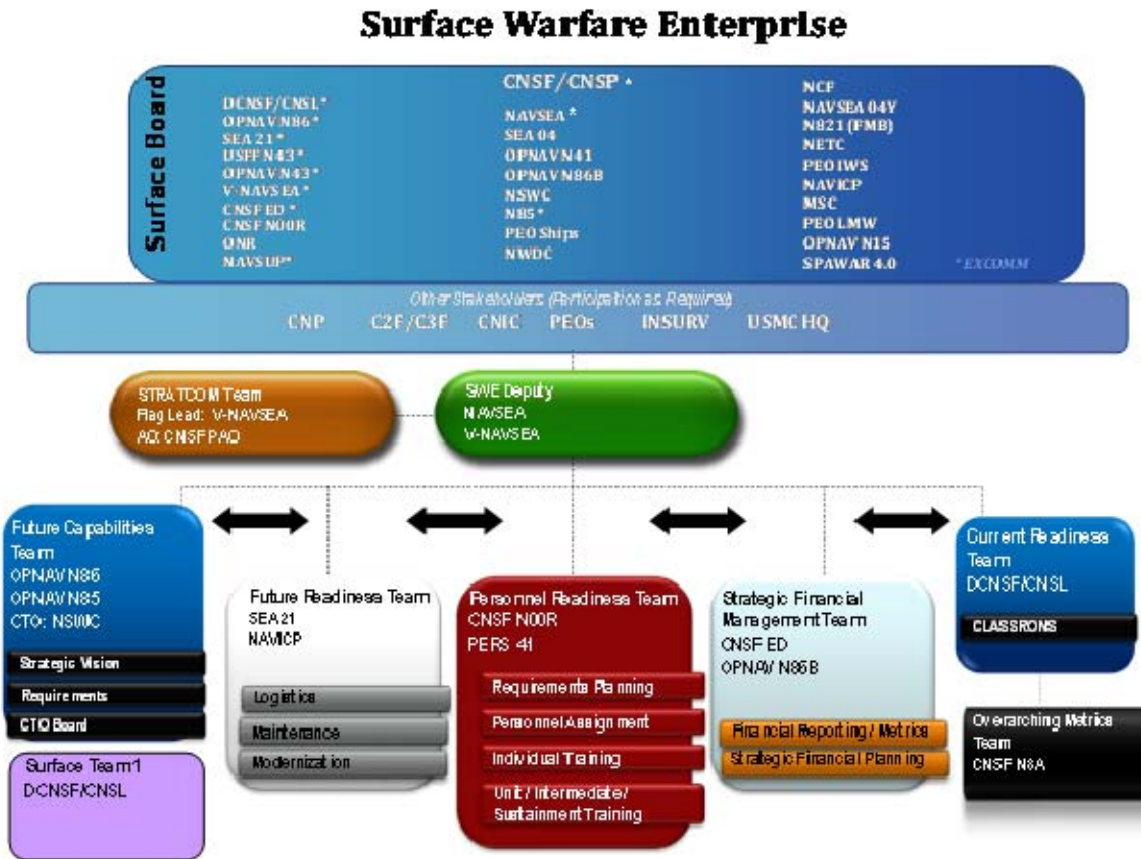

Figure 16. SWE Organization. (From: Commander, Naval Surface Forces SWE 101 Training Presentation, 2009)

1. Horizontal Elements

SWE's organization has both horizontal and vertical elements. The horizontal element is seen at the CFT level. This element is organized to eliminate boundaries within the surface navy, and allow for collaboration across the entire organization. Through this style of management, SWE is able to remove barriers within the organization and incorporate the right people into the decision making process. CFTs are

put together with personnel (military and civilian) from stakeholder commands to improve and manage the key processes related to the focus area of that specific team. There are a total of five major CFTs which were stated above. Below are the descriptions of each CFT taken from the SWE Charter:

- Future Capabilities Team (FCT) – led by the OPNAV Director of Surface Warfare (N86) and focuses on the delivery of affordable and effective capabilities that are appropriate for meeting a broad array of future challenges.
- Future Readiness Team (FRT) – led by Sea 21 and focuses on the optimization of support processes to deliver the required current and future readiness.
- Personnel Readiness Team (PRT) – led by CNSF Vice Commander and PERS 41 and focuses on delivering and retaining a diverse mix of officers, enlisted, civilians, and contractors with the right competencies and proficiencies.
- Strategic Financial Management Team (SFMT) – led by CNSF SES Executive Director and OPNAV N86B with the objective of making and influencing effective financial policy, management, stewardship, and program decisions.
- Current Readiness Team (CRT) – led by COMNAVSURFLANT and focuses on the current readiness of surface force manning, training, and equipment issues.¹³²

There are also three additional teams that provide support across the five CFTs. These teams are the Overarching Metrics Team, Strategic Communications Team, and Surface Team One. Below are the descriptions of each support team taken from the SWE Charter:

¹³² CNSF, *SWE Charter*, 10–12.

- Overarching Metrics Team (OMT) – led by CNSF N8A and provides consistent, replicable, and integrated SWE performance measures in a standard format to help support the Surface Board decision making process.
- Strategic Communications Team (SCT) – led by the SWE Deputy and centralizes and prioritizes communication tasks and goals through long-term planning and utilizations of communication tools.
- Surface Team One (ST1) – led by Deputy Commander, Naval Surface Forces and focuses on improving cross organizational maintenance processes in order to maintain and modernize the surface navy, meet expected ship service life, and address current material readiness challenges.¹³³

Each team has the capacity to set up a Barrier Removal Team (BRT). A BRT is chartered by the SWE Deputy and CFT leaders.¹³⁴ These teams are temporary in nature and stood up for a specific purpose. They are authorized to accomplish their given task then demobilize. A BRT focuses on the removal of a specific barrier(s) once it has been identified.

2. Vertical Elements

The vertical element ensures that SWE strategy can be turned into meaningful work by providing flow of information and tasking. This element allows strategy, concerns, and decisions to flow to the lowest level possible. Since SWE is a strategic level organization, deck plate sailors are affected by products of the SWE process and not actually part of its vertical element.¹³⁵ This vertical structure is best understood by illustrating how SWE addresses issues that are raised by the waterfront. Figure 17 shows the vertical alignment of SWE’s organization:

¹³³ CNSF, *SWE Charter*, 10–12

¹³⁴ *Ibid.*, 10–12.

¹³⁵ Smith interview.

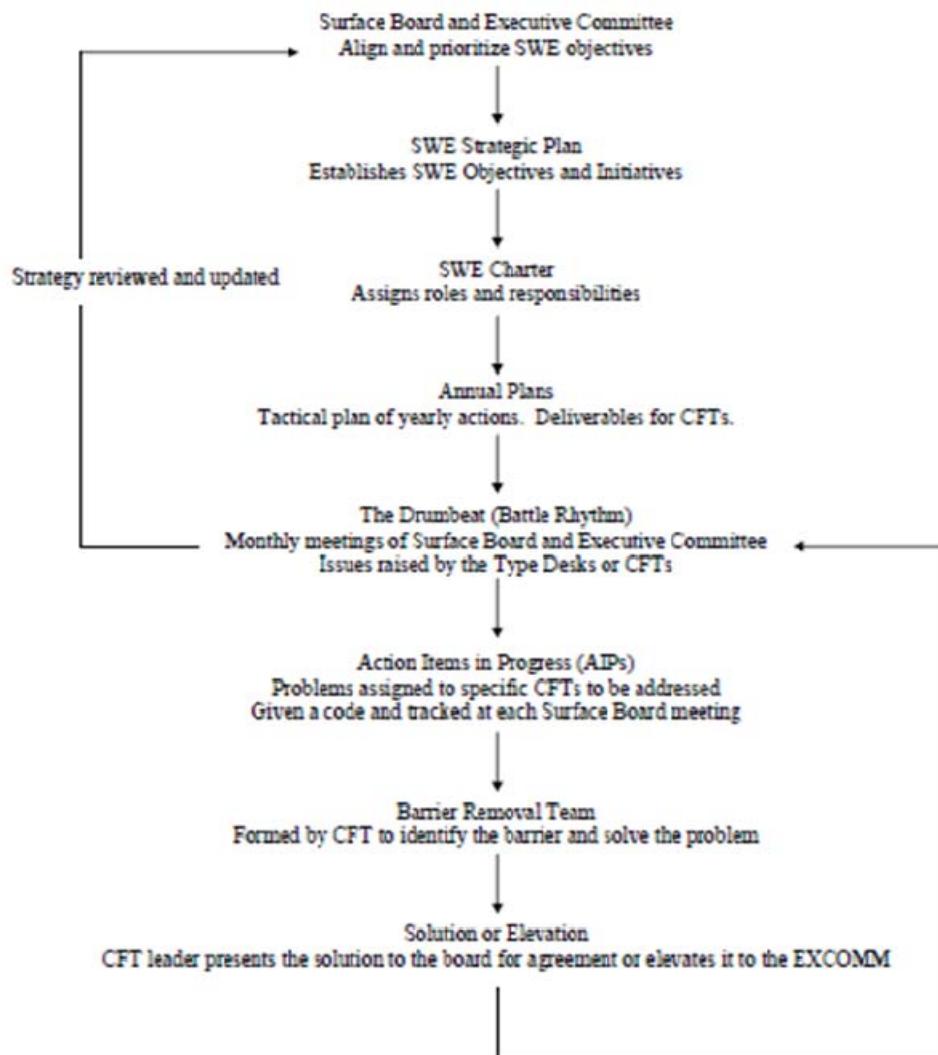

Figure 17. SWE Vertical Alignment.

The SWE strategic plan establishes the strategic objectives, and underlying initiatives from which the enterprise operates. These objectives have remained constant since SWE began in 2005. When the strategic plan was updated in 2008, VADM Curtis also had the SWE develop a charter that assigned specific roles and responsibilities, and established the battle rhythm of surface board and CFT meetings. Annual Plans are developed for every fiscal year and is a tactical plan of yearly actions from which the CFTs operate. These plans are derived from the strategic objectives and initiatives laid

out in the strategic plan, and mandated by the charter. The annual plan identifies the specific intentions, guidance, and deliverables for each CFT. This all comes together in a recurring drumbeat of monthly surface board and EXCOMM meetings. CFT leaders update the surface board on the status of items in their respective annual plans. New issues and concerns are also brought up by the type desks and CFTs, which are addressed by the board. If warranted, an action item in progress (AIP) will be issued with an identification number and assigned to a CFT for action. The CFT can address the AIP by standing up a BRT, which will identify any organizational barriers that have contributed to the problem, and determine a solution. The AIP solution is then presented to the surface board by the responsible CFT leader and is either closed (solution agreed on by all board members) or elevated to the EXCOMM for further consideration.

This vertical alignment of strategy and execution allows the lowest levels of the SWE to turn large strategy into meaningful work. It also provides leadership with necessary feedback of information to update or even change the strategic objectives if required.

E. GOVERNANCE

The surface board is the governing body of the SWE. It consists of flag officers and SES leaders that represent the key commands within the SWE.¹³⁶ These stakeholder commands are active participants in the processes that supply ready warships. Figure 16 lists the commands that have a seat in the surface board and identifies the members who also make up the EXCOMM.

1. Surface Board Responsibilities

The 2010 SWE Charter details the roles and responsibilities of the surface board and its members. The following outlines the duties of the surface board as designated by the charter:

- Align and prioritize Surface Warfare Objectives and action items to meet Combatant Commander and USFF/CPF requirements.

¹³⁶ CNSF, *SWE Charter*, 9.

- Approve, Direct, and prioritize changes to business processes to improve readiness at the right cost and timeframe.
- Review and approve updates to the Strategic Plan, Charter, and Annual Plan.
- Make funding decisions for People, Equipment, Supply, Training, and Ordnance (PESTO) pillars with respect to future capability and current readiness.
- Serve as the governing body that CFTs forward barriers to for resolution.¹³⁷

2. Membership

The SWE charter does not specifically state who must sit on the surface board. The guidance for what actually constitutes membership on the surface board is very loose.¹³⁸ These governing documents deliberately permit a wide amount of latitude as to who is going to be on the board because of the regularly occurring drumbeat.¹³⁹ The meeting schedule is set a year out with a loose knit guidance of what is going to be discussed.¹⁴⁰ Certain items up for discussion may require the presence of a command not normally represented at the board, but necessary for specific items. Or it may be determined that an emergent issue is best suited to be addressed directly up and down the chain of command for a quick response.

3. SWE Governance Support

The administrative office that directly supports the SWE Commander and management of surface board is the N40 SWE Support Office. N40 is manned with only three or four permanent officers assigned, an O6 SWE Executive Assistant, O4 Maintenance Analyst, supporting junior officers, and co-located Booz Allen consultants. N40 works directly for CNSF and enforces the regularly occurring drumbeat of

¹³⁷ CNSF, *SWE Charter*, 9.

¹³⁸ John Kochendorfer, interview held in San Diego, 14 September, 2010.

¹³⁹ Ibid.

¹⁴⁰ Ibid.

evolutions that bring all the board members and stakeholders together.¹⁴¹ This can be a challenge because surface board members also have their normal job responsibilities that can produce competing priorities when trying to get thirty flag officer equivalents, in the same place, at the same time, talking about the same issues.¹⁴² N40 also manages what is brought before the board by working across the different CFTs and making sure they all know what the expectations are, and that the right questions are being answered.¹⁴³ By acting as the SWE Commanders gatekeepers and disciplinarians, N40 is a key component to SWE governance and management of the surface board drumbeat.

F. LEADERSHIP

The decisions that are made here are the SWE priorities, because we get together and talk about it. We weigh them, and we discuss them to ensure that these are priorities about the fleet.

VADM D.C. Curtis, CNSF
15 September 2010

The key to SWE success is the belief in what the enterprise is capable of achieving.¹⁴⁴ Members within SWE must have a level of trust that allows them to voice their challenges and issues without reprisal. The two key leadership positions that provide the direction for the organization are the SWE Commander and Deputy Commander. Their responsibilities as detailed in the charter are listed below:

1. SWE Commander (CNSF)

- Establishes the SWE strategic direction.
- Promotes the SWE agenda to the FRE.
- Ensures SWE Deputy Commander and CFT leaders are aligned with SWE direction and guidance.

¹⁴¹ Kochendorfer interview.

¹⁴² Ibid.

¹⁴³ Ibid.

¹⁴⁴ Ibid.

- Approves SWE policy, procedures, business rules, roles and responsibilities.
- Sets agenda for Surface Board and EXCOMM meetings.¹⁴⁵
- Establishes SWE battle rhythm.

2. SWE Deputy Commander (NAVSEA)

- Collaborates with SWE Commander on establishing SWE direction.
- Orchestrates activities to execute the Strategic Plan, Charter, and Annual Plan.
- Assists in development of top level issues and ensures they are addressed at the appropriate level.
- Gives guidance, direction, and tools to CFTs.
- Charters Barrier Removal Teams (BRT) for priority tasks to remove barriers.
- Facilitates Surface Board meeting agendas.
- Ensures elevation of barriers to the Surface Board for resolution.
- Oversees collaboration between CFT action items.¹⁴⁶

3. CFT Leadership

Composition of the CFTs is also important to the success of SWE. The CFT leaders must have experience and knowledge that is relevant to the mission of that CFT. These leaders must be willing to openly discuss their problems, and have trust and confidence in other SWE leaders. If these leaders do not subscribe to the enterprise and its processes, then it is likely that the SWE will be less successful.¹⁴⁷ One factor that makes the distribution of leadership within the SWE difficult is the constant turnover within the ranks.

¹⁴⁵ CNSF, *SWE Charter*, 8.

¹⁴⁶ *Ibid.*, 8.

¹⁴⁷ Kochendorfer interview.

An important aspect in maintaining the right distribution of leadership and determining a position that will best suit the enterprise, is knowing what a leaders beliefs are, and from what angle they see enterprise behavior. Currently, SWE has a body of members that believe in the enterprise and are able to foster the behavior that makes enterprise practices successful in the surface navy culture.¹⁴⁸ Success of the SWE hinges on its leaders at all levels of the organization.

G. RESOURCE ALLOCATION

The effect SWE has on resource allocation is not one of direct control. In reality, the SWE commander does not control most of the surface navy resources. Instead, SWE affects resource allocation through influence. By establishing the priorities of the surface fleet, and discussing these priorities amongst the key stakeholders, the SWE is able to influence where resources should be allocated first.

1. Money

SWE has had an effect on money. Before the SWE, money traveled in pipes with stovepipe thinking and behavior.¹⁴⁹ With members of those stovepipes now belonging to the SWE, it is the same people just with more understanding and awareness of the priorities.¹⁵⁰ This is illustrated through the incorporation of OPNAV N43 Fleet Readiness Division into the enterprise. N43 became a member of the surface board and action officers on the Future Readiness Team. N43 remained in control of the 1B4B maintenance funding, but by being part of the enterprise, N43 is now forced to collaborate with NAVSEA program managers for various classes of ships and weapon systems.¹⁵¹ In terms of execution, 1B4B has stayed with N43 but was drawn into the influence of the enterprise.

¹⁴⁸ Kochendorfer interview.

¹⁴⁹ Smith interview.

¹⁵⁰ Ibid.

¹⁵¹ Ibid.

Enterprise behavior is largely focused on meeting long term goals. Money has to be earmarked and allocated years in advance to meet the needs of the surface navy. However, events develop that leave a command with a surplus of funds or in need of funds. SWE influences the allocation of money through conversations and decisions that are made during surface board meetings. Commands that are in need of additional funding express their desire during the surface board meeting through an AIP or CFT request. That need is then analyzed to see if there is a specific problem that is unique to one ship, an entire class, or a general problem that is affecting an entire fleet? Once this process is settled funds and or recommended policy changes are presented and a decision is made.

SWE also puts in their priorities on an annual basis for the Program Objective Memorandum (POM).¹⁵² Since these priorities are discussed and decided on by the surface board, it ensures that individual commands are not acting independently. The flow of money is no longer about which program manager has the loudest voice, but which one the entire body of SWE decides are the right priorities to spend money on. The SFMT is led by an SES who ensures this happens. The SFMT coordinates across all OPNAV Resource Sponsors and Budget Submitting Offices (BSOs) to ensure SWE priorities are addressed and represented in the POM and Program Reviews (PR).¹⁵³

2. Manning

Manpower and manning is the largest cost the navy faces and is the SWEs number one priority.¹⁵⁴ The PRT is charged with ensuring the right levels and quality of manning is present throughout the surface force. The largest flaw in the early business style approach taken before SWE was not realizing that war fighting requires excess capacity.¹⁵⁵ Past initiatives have looked to reduce the manning to optimal levels, which really focused on the minimum level. DDGs first deployed with approximately 320

¹⁵² Smith interview.

¹⁵³ Ibid.

¹⁵⁴ Ibid.

¹⁵⁵ Darren McPherson, interview held in San Diego, 15 September, 2010.

sailors, where now some have deployed with 220 sailors.¹⁵⁶ If there is not excess capacity, the navy may not be able to fulfill a required mission. In business, inventory costs money so reducing it through just in time practices meant saving that money. The business practices applied to the surface navy prior to SWEs development focused on minimums, including the minimum people required to man a ship.¹⁵⁷ These programs were developed to look at the manning and ships and attempt to reduce it, while maintaining a required level of readiness.

a. Top Six Roll Down

In order to lower the operational cost of a warship, the top six roll down program was developed. This initiative reduced the manning of E-4 to E-9 personnel on ships with the intent of lowering the cost of manning. In reality, the top six roll down took experienced sailors off of ships. For example, on a DDG the Quartermaster Chief (QMC) was the senior quartermaster onboard. This program rolled that billet down to a Quartermaster First Class (QM1) and the manning document authorized one QM1. The potential of gaining a person who is a rank above or below the authorized billet meant that a lead quartermaster on a DDG could possibly be a second class petty officer.¹⁵⁸ This affected the amphibious fleet hardest with the loss of experienced engineman (EN). ENs with no main diesel propulsion experience were being put in engineering plants where the main propulsion was diesel engines, and expected to be the leading petty officer (LPO). Phase II of this program was going to be implemented, but was stopped due to SWEs recognition of the negative effect removal of experience sailors was having on ships.¹⁵⁹

¹⁵⁶ McPherson interview.

¹⁵⁷ Ibid.

¹⁵⁸ Ibid.

¹⁵⁹ Curtis interview.

b. Optimal Manning

The optimal manning concept was a study designed to reduce the Total Ownership Cost (TOC) per ship. The largest cost in TOC is Operations and Support (O&S). O & S represents seventy percent of ships TOC. Of that seventy percent, fifty-one percent falls under manning.¹⁶⁰ When this program was developed it did not take into account the excess capacity required to effectively man and maintain a surface combatant. This problem was identified by SWE leadership in 2008 after the POM 10 budget was already done.¹⁶¹ Instead, it was reviewed and put into the POM 12 budget. Manning problems were largely identified by the SWE in 2008 and now 2200 sailors are returning to the fleet in 2011.¹⁶² Much of the work that was done by the SWE in 2008 is beginning to pay off now which shows the time it takes to identify a program, allocate money to it, and effect change.

H. SUMMARY

This chapter first presented a broad context of the SWE. It then discussed two important initiatives that began prior to SWE's development, SHIPMAIN and SHIPTRAIN. SHIPMAIN is significant because it was VADM LaFleur's first application of enterprise business practices in the surface navy. This led into the discussion of SWEs initial launch, and how the NAE and Thomas Group heavily influenced the formation of the SWE. It also listed the external and internal factors that led to SWEs development.

The chapter then looked at SWEs progression during the tenure of VADM Etnyre and the current SWE Commander, VADM Curtis. During the first two years of SWE operations, a lot of the work was focused on gathering the right data, and developing the strategic plan of the organization. CLASSRONs were also begun within the first year to be the interface between the SWE and the fleet. SWE leaders were given corporate

¹⁶⁰ Naval Research Advisory Committee, *Optimized Surface Ship Manning*: Research Report (Washington D.C.: Office of the Assistant Secretary of Defense RDT&E, 2006), 25.

¹⁶¹ McPherson interview.

¹⁶² Curtis interview.

labeled positions and became associated with attempting to run the surface navy as a business. March 2008 was an important month for SWE as it marked a dramatic shift in enterprise direction. VADM Curtis has sought to change the tone of the enterprise by using enterprise behavior practices in a warfighting organization focused on effectiveness, and not so much on efficiency. A timeline was also presented to help illustrate SWE's evolution along with major enterprise milestones in the larger navy.

A small section about the Enterprise Maturity Model was also presented in order to provide an understanding of the primary oversight tool that SWE uses to determine its ability to operate as an enterprise. The EMM is important to understand because it is how SWE assesses itself as it attempts to mature.

The next section of the chapter focused on SWE's organization and alignment. First, an organizational chart showed all elements of the SWE organization. The horizontal element and its importance in removing organizational barriers were explained. The roles and responsibilities of the cross-functional and supporting teams were all defined. The vertical element of the organization was presented through a flow chart illustrating how SWE strategy is pushed to the lowest level of the enterprise. It also made the distinction that SWE is a strategic organization where sailors on the deck plates are recipients of the SWE decision-making process.

Governance was addressed by looking at the membership and role of SWE's governing body, the surface board. It outlined the responsibilities and membership of the board. This section also explained the looseness of the governing documents in SWE's attempt to remain flexible given the frequency of meetings, and possible conflicting priorities board members may have with their normal job responsibilities. The role that the N40 SWE Support office plays in managing the governing body is also important.

The leadership section began with a quote from the SWE Commander, VADM Curtis, which illustrates what SWE leadership must be able to do. An important characteristic SWE leaders must have is the ability to be open, honest, and discuss items important to the surface navy. SWE can only be led by leaders who believe in what the enterprise is capable of achieving. The responsibilities of the two key leadership

positions, the SWE Commander and Deputy Commander were presented, along with a discussion of leadership distribution throughout the entire organization, but more specifically, the CFTs.

The final section of the chapter attempted to explain how SWE is able to effect resource allocation through influence and establishment of priorities. Specific examples of effects on money and manning were specified, however, this data is not sufficient enough to show how SWE affects the systematic process of resource allocation. A more detailed explanation and recommended areas for further research are provided in the concluding chapter.

Throughout this chapter, findings from archival research and interview data were presented in order to answer the primary and secondary research questions of the project. These findings provide a clear understanding of how SWE has implemented enterprise management, how it is organized, governed, led, and some effects these practices are having on resource allocation. This understanding will provide the foundation for analysis and assessment of SWE's implementation of enterprise management in the following chapters.

THIS PAGE INTENTIONALLY LEFT BLANK

IV. ANALYSIS OF SWE ENTERPRISE MANAGEMENT IMPLEMENTATION

A. INTRODUCTION

This chapter provides an analysis of SWE based on an analytical framework drawn from the corporate literature presented in chapter two. As discussed in the previous chapter, SWE has implemented enterprise practices at a strategic level. Surface leaders use enterprise management as a behavioral tool to ensure cross-organizational collaboration, and attempt to influence resource allocation throughout the entire force. In an attempt to maximize this influence, SWE has applied practices common to corporate enterprises. The purpose of the analysis is to assess SWE's implementation of enterprise organization, governance, and leadership practices in relation to ideas and models common to these successful business enterprises. Each section will begin with a framework table to organize the topics being analyzed. At the end of each section a review table will be presented that summarizes how SWE has implemented those specific topics.

The chapter will first analyze SWE's organization. This section will focus on analyzing SWE's main thing, its vertical and horizontal elements, and three levels of management. The next part of the chapter will focus on governance by analyzing the culture of the surface board, its performance, and communicative interaction. The last section will analyze SWE's distribution of leadership throughout the organization.

B. ANALYSIS OF SWE ORGANIZATION

This section will focus on analyzing the concepts of organization and alignment. First, Labovitz and Rosansky present ideas on alignment that raise a few questions. What is the organizations main thing? Are vertical and horizontal elements present that ensure the organization stays centered on that main thing? Second, according to Burton and Moran, three levels of management must be present for an organization to remain focused on the future and meet long-term objectives. Table 1 is the framework that will be used to analyze SWE's organization.

Analysis Topics	Definition
Main Thing	The single most powerful expression of what it hopes to accomplish, a common and unifying concept to which every unit can contribute.
Vertical Element	All employees understand organization-wide goals and their role in achieving them. Strategy converted to meaningful work at the lowest level.
Horizontal Element	Eliminates the boundaries within the organization. Incorporates the right people into the decision making process.
Strategic Management	A permanent structure in an organization, focused on the development and deployment of strategic goals to all levels of the daily management work units.
Lateral Management	Alliance based structure, concentrates on organization wide goals and objectives, develops solutions that break down barriers.
Daily Management	A permanent but routine structure, focuses on the routine daily work that converts inputs into outputs, continuously improves routine processes, comprises a majority of the employees, internally focused but should be ready to adapt as the organization strategic management changes direction or emphasis.

Table 1. Framework for Analysis of SWE Organization.

1. SWE's Main Thing

SWE's main thing is ensuring warships are ready for tasking, at the right cost, right place, and right time. This is stated in the 2010 strategic plan and is found in numerous SWE publications. It has been its focusing statement since 2005. It is SWE's most powerful expression of what it hopes to accomplish and is a common and unifying concept to which every unit in the surface navy can contribute.¹⁶³ Through interviews of

¹⁶³ Labovitz and Rosansky *Power of Alignment*, 40.

successful CEOs, Labovitz and Rosansky were able to identify five simple steps to determine and align an organization to the main thing. Two of these steps relevant to this analysis were:

- Define critical strategic goals and imperatives and deploy them throughout the organization.
- Tie performance measures and metrics to those goals.¹⁶⁴

SWE determined its main thing in conjunction with strategic objectives and initiatives that would drive the organization toward that main thing. These objectives have remained in place since 2006 while the supporting initiatives have had minimal changes. SWE also developed metrics and performance measures that were tied to its goals. An example of this is the Enterprise Maturity Model, which is used to assess the progress of the SWE as an enterprise. In addition to the EMM, SWE has also developed numerous metrics related to results, cost, and processes. Examples of each type of metric are Maintenance Figure of Merit (MFOM), First Pass Yield, and Fuel Costs per Month. These metrics are used to identify trends, and determine whether or not action is necessary to achieve the main thing. Each CFT has metrics and performance measures tied to the goals of their specific CFT as well.

SWE's ultimate goal is to have a mature enterprise where everyone, at every level is moving in the same direction. At a strategic level, this is beginning to happen. The establishment of a battle rhythm where decision makers from each major surface navy organization and command are together every month creates a sense of direction and purpose among the senior leaders. This has allowed the surface board to better align resources and systems to ensure they are integrated and focused on SWE's main thing.

According to Labovitz and Rosansky, constant connection to the main thing is vital to an organization's success. To achieve this, managers and workers alike must be linked to the main thing, and must understand their role in contributing to it. Right now, sailors are recipients of the SWE process and not directly incorporated into the organization. This is intentional since enterprise practices were implemented at a strategic level to fix the stovepipe decision-making that was degrading ship readiness.

¹⁶⁴ Labovitz and Rosansky *Power of Alignment*, 41.

However, Labovitz and Rosansky state that to be truly aligned, all levels of the organization must link elements of strategy and people to customers and process improvements to ensure everyone understands the main thing. Early process improvement initiatives such as TQM and business re-engineering failed to link people to the main thing and led to a lot of teams, working on a lot of problems, but with no real connection to the main thing.¹⁶⁵ Figure 18 takes the model presented by Labovitz and Rosansky in chapter two and, applies it to the existing relationship of these elements to SWE’s main thing.

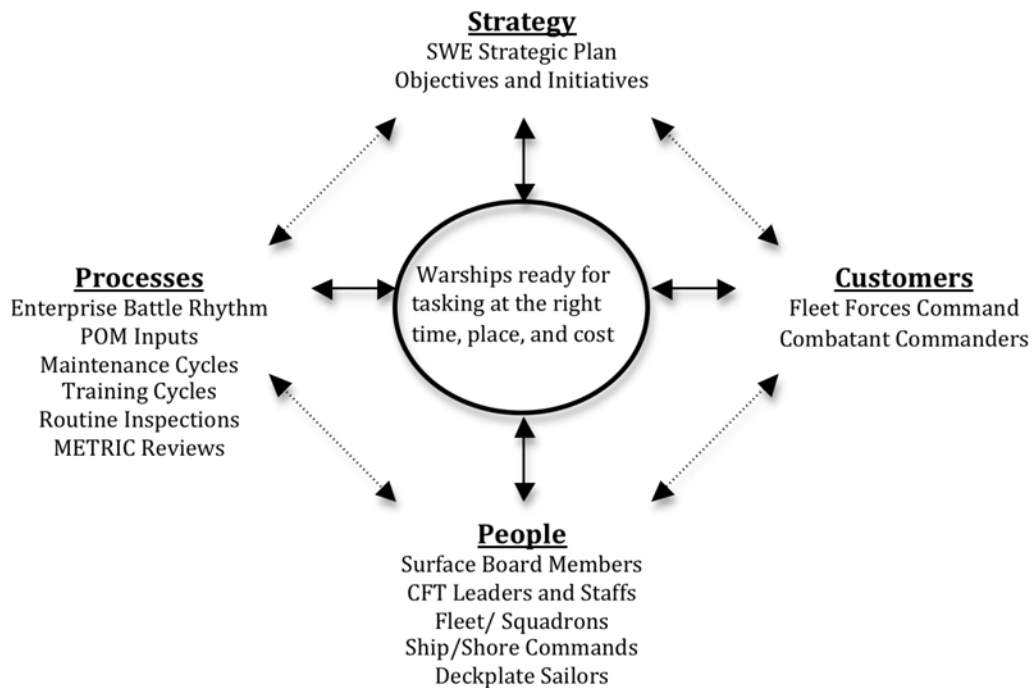

Figure 18. SWE Element Links to its Main Thing.

a. Strategy

Strategy and objectives have remained connected to the main thing since 2006. The surface board reviewed and updated the strategic objectives in 2008 and 2010.

¹⁶⁵ Labovitz and Rosansky *Power of Alignment*, 11.

b. Processes

Processes are beginning to provide more output. A consistent schedule of surface board meetings allows decision makers to present unified priorities for POM inputs. SWE is also able to better track individual ships and ship classes through review of metrics. For example, SWE can see every cruiser that spends the most money, least money, has the most CASREPS, and how they are compared to the rest of the class. This holistic view has given SWE the ability to improve maintenance and training cycles for each class of ship.

c. Customers

SWE is a force provider to FFC and the Combatant Commanders. Thus FFC and the CoComs can be viewed as the SWE's customers. In 2008, SWE leadership identified the negative effect that a combination of simultaneous initiatives (manning reduction, training reform, and streamlining of maintenance) developed separately from one another in the early 2000s was having on ships readiness. This trend became evident from 2005 through 2009 in which fourteen percent of ships failed INSURV, compared to three and a half percent from 1994 through 1999.¹⁶⁶ In its attempt to remain aligned with its primary customer, FFC, SWE has addressed these concerns by re-allocating resources to ensure ships are ready for the inspection, and focused on effectiveness. So far this has resulted in zero INSURV failures for FY 2010.¹⁶⁷ SWE is also returning 2,200 billets to ships in an attempt to increase ship manning to levels required for effective ship operation and maintenance. Since 2008, SWE has been focused on correcting the negative effects stove piped initiatives have had on the fleet, and improving its alignment with FFC.

d. People

SWE has been able to successfully incorporate multiple command structures throughout the surface navy into a cohesive organization. CFTs have been able

¹⁶⁶ Ewing, *Lean Manning*, 1.

¹⁶⁷ Peter Opsal, interview held in San Diego, 14 September, 2010.

to work across the organization and involve personnel from different levels of the surface navy. SWE has been able to effectively employ enterprise management at a senior and strategic level. Currently, deck plate sailors, mainly O-3 division officers and below, have had minimal or no exposure to the SWE. It is not necessary that every sailor know details about the SWE, but in order to align the people element of the surface navy, Labovitz and Rosansky would argue that sailors at all levels should have an understanding of how they contribute to what the SWE is trying accomplish. Sailors should also know that their leadership is willing to openly discuss issues so decisions and priorities have the best interest of the fleet in mind.

2. Vertical and Horizontal Elements

SWE's ability to recognize the interrelated programs that were severely impacting ship readiness illustrates the capacity it has to center the organization. According to Labovitz and Rosansky, the ability to remain centered relies on a combination of vertical and horizontal elements in an organization.¹⁶⁸

Currently, SWE is horizontally organized and aligned through CFTs. These CFTs are removing barriers within the organization and incorporating the right people into the decision making process. The organization of this horizontal element allows CFTs to be empowered by their leaders, and make decisions so the SWE can move forward.¹⁶⁹

The SWE is also showing aspects of vertical alignment. According to Labovitz and Rosansky, the vertical dimension is concerned with organizational strategy and the people that are relied on daily to transform strategy into meaningful work. They also state that when executive level leaders and managers develop strategies in isolation from the people who execute them, it is inevitable that the strategies will not be successfully incorporated into the environment of the low level employees. SWE strategy is determined, tracked, and updated through the surface board, in which inputs are given from key stakeholders throughout different levels of the surface community. However, full vertical alignment is not reached until all employees (sailors) understand

¹⁶⁸ Labovitz and Rosansky *Power of Alignment*, 10.

¹⁶⁹ Curtis interview.

organization-wide goals and their role in achieving them. A similar separation was present when Navy leadership began implementing the FRP. A GAO report published in 2005 cited that although the FRP was communicated heavily to senior leaders, the plan did not flow through the lower level ranks, which led to personnel not being aware of the scope, goal, and other aspects of the plan.¹⁷⁰

3. Levels of Management

A factor in SWE's success is its ability to move the surface navy into the future, and achieve the long-term goals set by leadership. Burton and Moran argue that for an organization to be successful in planning and managing long-term objectives there must be three levels of management present in the organization: strategic, lateral, and daily.¹⁷¹ Figure 19 applies their model to SWE levels of management.

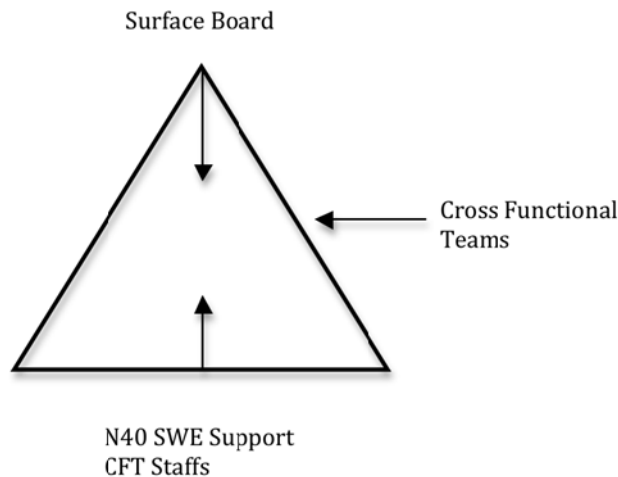

Figure 19. SWE Management Structure.

The surface board develops, manages, and pushes the strategy of organization to the lowest possible level. CFTs work to across the surface navy in an attempt develop

¹⁷⁰ United States Government Accountability Office, *Military Readiness: Navy's Fleet Response Plan Would Benefit From A Comprehensive Management Approach and Rigorous Testing*. (Washington D.C.: Government Accounting Office, 2004), 21.

¹⁷¹ Burton and Moran, *Future Focused*, 31.

the best solutions and implementation of decisions. SWE support and CFT staffs work daily to gather data from the enterprise to ensure the right questions are being answered, and provide information to the surface board that requires their attention or decision.

a. Strategic Management

Strategic management is defined by Burton and Moran as a permanent structure in an organization that is focused on the development and deployment of strategic goals to all levels of the daily management work units.¹⁷² In the SWE, this level represents the surface board and executive committee. By comparing the role of the surface board presented in chapter three to the required functions of the strategic management level presented by Burton and Moran, it can be determined that SWE’s strategic management level meets these functions. Figure 20 shows the surface board functions and the required functions for strategic level management as outlined by Burton and Moran.

<u>Surface Board Functions</u>	<u>Required Functions</u>
Align and prioritize Surface Warfare Objectives.	Focus on keeping the right course.
Approve, direct, and prioritize changes to business processes.	Plan majors shifts in emphasis, needs, and expectations.
Updates the Strategic Plan, Charter, and Annual Plan.	Work on common areas that are causing obstacles in meeting strategic goals.
Make funding decisions for PESTO pillars with respect to future capability and current readiness.	Align routine daily work with strategic effectiveness and efficiency goals.
Serve as the governing body that CFTs forward barriers to for resolution	Develop appropriate structure to meet desired goals.

Figure 20. Surface Board and Required Strategic Level Management Functions.

¹⁷² Burton and Moran, *Future Focused*, 31.

b. Lateral Management

Burton and Moran define lateral management as more of a temporary, alliance-based structure in the organization that concentrates on organization-wide flexibility goals and objectives.¹⁷³ This level of management is where solutions are developed and organizational boundaries removed. This is partially true in the SWE. CFTs are a permanent part of the SWE management organization; however, there is no Current Readiness Team command for example. The leaders and members of each team have routine duties within normally assigned commands. Much like the surface board, CFTs meet on a routine basis as outlined in their annual plans. Each team is responsible for their assigned areas, but SWE's charter puts an emphasis on close collaboration across all CFTs. Each CFT uses Barrier Removal Teams that are temporarily set-up, with a specific problem to address. These BRTs can also have members from other CFTs as needed to address multi-discipline issues. Figure 21 compares the characteristics important to the lateral management level according to Burton and Moran, and CFT responsibilities as outlined in the SWE Charter.

¹⁷³ Burton and Moran, *Future Focused*, 32.

<u>CFT Responsibilities</u>	<u>Required Functions</u>
Assist Surface Board in defining key processes, metrics, tools, and content for training necessary to enable alignment, execution, and identification of future requirements.	Management involvement based on inter divisional cooperation.
Maintain an approved charter and conduct productive interaction to support SWE battle rhythm.	A horizontal integration process to help an organization achieve efficient organization flexibility goals.
Serve as the first level of barrier identification and removal.	Organizational barrier breaking approach that reduces complex layering.
Manage a plan to support collaborative solutions to meet strategic and annual plans.	A process to deploy top level management functions.
Conduct process analysis based on metric trends and recommend COAs to the enterprise.	A cultural change agent.
	A process to define the common ground between functional units and facilitate the flow of horizontal work.

Figure 21. CFT Responsibilities and Required Lateral Management functions.

c. Daily Management

Daily management is a permanent but routine structure in an organization that focuses on the daily work that converts inputs into outputs.¹⁷⁴ Since this research has identified that deck plate sailors and operational units are only recipients of the SWE decision-making process, this analysis does not consider them as part of the SWE daily management level. Instead, this level is best represented by analyzing the functions of N40 SWE Support and CFT staffs. N40 works directly for the SWE Commander and with all CFTs. The CFT staffs give inputs to the N40 staff, which schedules the surface board meetings, and manages what is brought before the board. The outputs are surface board decisions or AIPs.

¹⁷⁴ Burton and Moran, *Future Focused*, 34.

4. Review Table

Table 2 summarizes SWE’s application of enterprise organization.

Analysis Topics	Definition	SWE Application
Main Thing	The single most powerful expression of what it hopes to accomplish, a common and unifying concept to which every unit can contribute.	“Warships ready for tasking, at the right place, the right time, and right cost.”
Vertical Element	All employees understand organization-wide goals and their role in achieving them. Strategy converted to meaningful work at the lowest level.	Process in place to convert strategy to meaningful work at the lowest level through strategic initiatives and CFT annual plans. Current gap in enterprise understanding as many O-3 and below sailors are not aware of the SWE, and their contribution to its main thing.
Horizontal Element	Eliminates the boundaries within the organization. Incorporates the right people into the decision making process.	Cross-Functional Teams, and Barrier Removal Teams. Each CFT has a focused area, but cross-collaboration is a standard practice to ensure removal of organizational barriers.
Strategic Management	A permanent structure in an organization, focused on the development and deployment of strategic goals to all levels of the daily management work units.	EXCOMM and Surface Board comprised of senior surface leaders and stakeholder commands. Governing body of the organization and ensures surface warfare priorities are aligned throughout all levels and elevated to Echelon I and II leaders.
Lateral Management	Alliance based structure, concentrates on organization wide goals and objectives, develops solutions that break down barriers.	Five CFTs with three supporting teams. Members have duties in separate commands, but come together routinely as designated in their annual plans. Focused on collaborative solutions, first level of barrier identification and removal.
Daily Management	A permanent but routine structure, focuses on the routine daily work that converts inputs into outputs, continuously improves routine processes, comprises a majority of the employees, internally focused but should be ready to adapt as the organization strategic management changes direction or emphasis.	Consistent collaboration among N40 SWE Support and CFT Staffs. Civilian government employees and Co-located Booz Allen consultants provide strategy and tactical support.

Table 2. Summary of SWE Organization Analysis.

C. ANALYSIS OF SWE GOVERNANCE

This section will focus on the concepts of governance by analyzing how the SWE surface board works. Margot Cairnes discusses the effects behavioral dynamics have on effective decision-making in the boardroom, in board committees and by senior executives.¹⁷⁵ This discussion raises a few questions. What defines good governance? How can governance be analyzed? As the surface board serves as the SWE governing body, its successes and failures are directly correlated to SWE. By utilizing the Four Processes of Good governance diagram, this section will analyze governance in relation to the SWE surface board. Table 3 is the framework that will be used to analyze SWE’s governance.

Analysis Topics	Definition
Board Processes	Recognizes the requirement to implement good processes. However, even the best processes are driven by people, who in turn driven by personal and group based factors. Processes only work well when people operate them well.
Board Malfunctions	Notices the early warning signs that indicate these processes are malfunctioning and could cause problems later on
Board Dynamics	Understands the human dynamics that create these malfunctions and how these dynamics can change for better decisions
Board Culture	Ensures that the environment is optimal for continuing good governance. This may require modifying processes to incorporate lessons learned during the first three processes.

Table 3. Framework for Analysis of Surface Board Governance.

¹⁷⁵ Cairnes, *Boardroom*, 5.

1. Board Processes

In order for a board to be successful, processes need to be in place that allow for implementation of new procedures.¹⁷⁶ SWE surface board does this by facilitating an open flow of communication between its members. This open flow of communication and information serves as the process. The ability for members of the board to introduce new ideas without the fear of reprisal is a pivotal method within the SWE. Based on observations made at a surface board meeting this procedure of going around the room (in some cases a virtual room) and openly discussing and debating ideas until they become action items is the fundamental tool in the success of SWE.

2. Board Malfunctions

The surface board is made up of stakeholders from senior leadership positions throughout the navy. Each one of these members has a vested interest in the success of the company. Unlike civilian run corporations, which may have different compensation packages for each of the board members, the only separation in the surface board is one of rank. Each member's bona-fide interest in the success of the organization is vested in personal pride and patriotism. Margot Cairnes describes several scenarios in which you would notice a breakdown in how a board functions. It is difficult for people inside a group to recognize and to judge when and how the group is dysfunctional, because their behavior in the group is largely subconscious.¹⁷⁷ SWE uses the EMM as an internal auditing tool to track how it is developing as an enterprise organization; however, SWE does not currently employ an external oversight instrument to evaluate the performance of the surface board.

3. Board Dynamics

The surface board is run by human beings, which means it is subject to social behavior that can sub-optimize its performance. Margot Cairnes discusses how failures occur within organizations. She states that "when failures occur in an organization

¹⁷⁶ Cairnes, *Boardroom*, 7.

¹⁷⁷ Cairnes, *Boardroom*, 11.

people think that one individual, or group of individuals, is incompetent or has engaged in malevolent behavior...”¹⁷⁸ This is a possible scenario in any board of directors to include the SWE Surface Board. The SWE Surface Board is designed to not be controlled by one person. The members have a vested interest in their own commands, and will fight for every attribute that will increase the worth or capabilities of the area they are responsible for. These are reached without the intent of ruining another members, career, command, or program, but for the benefit of the entire organization.

4. Board Culture

To ensure the environment is adequate for the flow of ideas, the surface board meets on a monthly basis and together once a year face to face. The normal meetings are conducted via Virtual Telecommunication Connection (VTC). The VTC technology allows for board members to appear as if they are in the same room with the commands that are present. Once a member desires to speak, the technology puts him “virtually” in a room on a monitor. This member is now speaking real-time face to face with the other SWE board-members. This environment allows for the open flow of communication because all of its stakeholders are present at the same time. Information is passed electronically, and decisions are made in front of everyone, with all members either agreeing or dissenting in full view of the entire board.

¹⁷⁸ Cairnes, *Boardroom*, 19.

5. Review Table

Table 4 summarizes SWE analysis of Surface Board governance.

Analysis Topics	Definition	SWE Application
Board Processes	Recognizes the requirement to implement good processes. However, even the best processes are driven by people, who in turn driven by personal and group based factors. Processes only work well when people operate them well.	SWE has an open framework which allows processes to be developed with all parties present can provide input and share ideas.
Board Malfunctions	Notices the early warning signs that indicate these processes are malfunctioning and could cause problems later on	SWE is lead by a panel, and not one CEO. Operates without external oversight.
Board Social Dynamics	Understands the human dynamics that create these malfunctions and how these dynamics can change for better decisions	All members have a common goal and are vested with the best interests of the Surface Navy.
Board Culture	Ensures that the environment is optimal for continuing good governance. This may require modifying processes to incorporate lessons learned during the first three processes.	VTC technology allows for all SWE stakeholders to discuss SWE topics face-to-face

Table 4. Summary of SWE Governance Analysis.

D. ANALYSIS OF SWE LEADERSHIP

Leadership and how it is distributed is the glue of an organizations alignment.¹⁷⁹ This section will focus on analyzing SWE's leadership with respect to how it is distributed throughout the organization, and how well it compares to the responsibilities and behavioral functions outlined by Burton and Moran. Table 5 is the framework that will be used to analyze SWE's organization.

¹⁷⁹ Labovitz and Rosansky *Power of Alignment*, 170.

Leadership	Definition
Distribution	Presence of capable leadership in different units and at different levels of an organization.
Responsibilities	Develop and distribute strategy, explain, council, and coach lower level managers, foster enthusiasm and trust in lower levels by empowering people, and delivering resources for them to accomplish the strategic direction they established, ensure people understand what is expected.
Behavioral Functions	Leadership willing to practice and perform four critical behavioral functions: Chosen thought, conscious speech, consistent action, and constant care.

Table 5. Framework for Analysis of SWE Leadership.

1. Leadership Distribution

Distributed leadership is defined by Labovitz and Rosansky as the presence of capable leadership in different units and at different levels of an organization.¹⁸⁰ For the surface board and CFTs to be effective, leadership must believe in the enterprise and what the board is trying to accomplish. SWE requires leadership willing to openly discuss their problems, and demonstrate trust and confidence in all levels of the organization. This distribution is made difficult for SWE by the constant rotation and position changes of Flag Officers and senior commanders. This frequent rotation poses two large challenges:

- Managing surface board membership.
- Ensuring proper CFT leadership that is enthusiastic about SWE and capable of providing guidance and direction for their respective teams.

With this high level of rotation, new leadership must continually be incorporated into surface board meetings, which can have a profound effect on the dynamic of the entire organization.

How each CFT is composed is also an important aspect to SWE's effectiveness as an organization. Dimancescu says that CFTs should be composed of people who know and live with a process and have day-to-day responsibilities taken from across an

¹⁸⁰ Labovitz and Rosansky, *Power of Alignment*, 170.

organizations divisions, departments, suppliers, or customers.¹⁸¹ SWE CFTs are set up with senior leaders in charge who have the right personnel and resources to run that specific CFT. For example, SWE's Strategic Financial Management Team is led by a senior executive service member who has the most experience and capability in dealing with money and resources. Another example is the Personnel Readiness Team led by the Vice CNSF and PERS 41, which has all the resources and personnel to address concerns related to manning. This composition and distribution of leadership is vital to SWE's ability to link divisional and departmental activities through horizontal communication.

2. Responsibilities

According to Burton and Moran, an organizations leadership has responsibilities that are largely based around the strategy of the organization. These responsibilities are focused on developing the strategy, providing guidance and council on how to execute it, delivering resources to accomplish it, and being accountable for the outcome.

SWE leadership has developed an appropriate strategic plan that is detailed, and easily understood. With recurring meetings of surface board members, the SWE commander, deputy commander, and CFT leaders are able to coach lower level personnel in their planned direction, and ensure people understand what is expected. In this forum, SWE leadership is also able to influence the allocation of resources in an attempt to provide surface leaders and managers the resources needed to accomplish the strategic direction.

Additionally, Burton and Moran argue that leadership also has the responsibility to develop trust in all levels of the organization by empowering people in the execution of strategy. This research has identified a gap in SWE knowledge at the deckplate level of the surface navy. SWE leadership has also identified this and has developed a strategic communications plan for the 2009 through 2011 time period to address it. The purpose of this plan is to bring the SWE message to the right audience. Through the Strategic Communications Team, SWE leadership is attempting to push strategy, enthusiasm, and knowledge to both internal and external stakeholders. According to

¹⁸¹ Dimancescu, *Seamless Enterprise*, 19.

Burton and Moran, if personnel understand their contribution to the strategy set by leadership, and receive the resources necessary to achieve it, they will be empowered to accomplish it.

3. Behavior

SWE is still developing as an enterprise organization. As the organization continues to incorporate a holistic type of management, Burton and Moran assert that leadership must perform four critical behavior functions. These functions were determined so leadership could better understand the impact their behavior has on the organization as it attempts to transform its style of organization and management.

a. Chosen Thought

This involves leadership evaluation of the organization as a system. The focus should be on the sharing of information, review of data, and improvement of processes. SWE leadership puts a lot of emphasis on measuring and analyzing the system through metrics; some examples of these metrics were given in the previous chapter. These metrics are shared throughout the organization, and gives leadership the ability to address different parameters of a problem situation, instead of defaulting to people as the problem. Where this becomes difficult is transferring the information SWE leaders get out of these performance metrics, to funding and policy decision makers that are not part of the organization.

b. Conscious Speech

What leadership says affects the tone for cultural change in the organization. Leadership must focus on improvements, encourage questions, discuss critical processes, and focus on breakthroughs. This is evident in current SWE leadership. The culture that SWE leadership has established during surface board meetings facilitates an open and honest discussion between leaders at different levels of the organization. The current SWE commander emphasizes the importance of the discussion, rather than the quality of the presentation.

c. Consistent Action

Leadership must apply consistent behavior throughout the organization. This is more of a challenge for SWE leadership given the complexity of the system, and the number of stakeholders in the organization. Consistency is also difficult with continuous rotation of leadership. As discussed in the previous chapter, the tone of SWE changed dramatically with a new SWE commander and strategic consultants in March of 2008. The current leadership has developed a strategic plan and charter that provides guidance and structure to the organization. This will provide some consistency during leadership transitions, however, the direction of SWE will be largely determined by how its future leadership views, and applies enterprise practices.

d. Constant Care

Leadership must continuously ensure people that they are on the right course. They do so by providing resources, training, rewards, and recognition for appropriate behavior and accomplishments. SWE leadership has an internal rewards and recognition program that allows leadership to recognize outstanding performance and contribution to the SWE effort. Another program that rewards the appropriate behavior is NAVSEA's Incentivized Energy Conservation initiative (i-ENCON). This program rewards underway ships who use less fuel than the class average for that particular ship. A cash incentive is given to leading fuel conservers that can be used to improve a ships readiness level by sending sailors offsite to continue professional education and qualifications. These are examples of programs that involve SWE and can re-enforce the behavior SWE is trying to implement on a larger scale.

4. Review Table

Table 6 summarizes SWE’s application of enterprise leadership.

Leadership	Definition	SWE Application
Distribution	Presence of capable leadership in different units and at different levels of an organization.	SWE leadership must believe in the enterprise approach. Constant rotation of Flag Officers poses challenges to surface membership, and maintaining CFT effectiveness. CFT leaders have the right personnel and resources to run their CFTs. The right distribution of leadership is vital to SWEs horizontal communication ability.
Responsibilities	Develop and distribute strategy, explain, council, and coach lower level managers, foster enthusiasm and trust in lower levels by empowering people, and delivering resources for them to accomplish the strategic direction they established, ensure people understand what is expected.	SWE leadership has developed an enterprise strategy and is distributing it to all surface navy levels via their strategic communications plan. A constant meeting of surface board members also allows leadership to ensure people understand what is expected. Leadership prioritizes requirements and attempts to maximize the influence in the resource allocation process.
Behavioral Functions	Leadership willing to practice and perform four critical behavioral functions: Chosen thought, conscious speech, consistent action, and constant care.	SWE leadership is showing aspects of all four functions. Consistent action is difficult to achieve due to the complexity of the SWE system, and rotation of leadership. Governing documents and practices provide some consistency, but the direction of SWE is still determined by leadership views.

Table 6. Summary of SWE Leadership Analysis.

E. SUMMARY

This chapter provided an analysis of SWE’s implementation of enterprise management through the framework of organization, governance, and leadership. It used the models and concepts presented in the literature review as a tool for evaluation.

The analysis of SWE’s organization identified how different elements are linked to SWE’s main thing, warships ready for tasking. It uses horizontal organization to maximize cross-collaboration and remove organizational barriers. Although SWE is a horizontal structure, there is still a vertical element that allows strategy to be pushed to the lowest level of the organization. It is also recognized that sailors on the waterfront are recipients of the SWE decision making process, and act indirectly in implementing the priorities established by SWE. This analysis also identified the three levels of SWE’s management structure as the surface board, cross-functional teams, and SWE support.

The analysis of SWE's governance analyzed four characteristics that describe its governing body, the surface board. It determined that the open flow of communication and discussion is the main process of the surface board. It identified a shortfall in external oversight that is commonly used to oversee boards of directors in corporate structures. It looked at how personal behaviors and agendas can influence the effectiveness of decisions made by the board. This analysis identified the culture of the surface board and determined that recurring face to face to interaction has fostered an environment of shared beliefs and understandings.

The analysis of SWE's leadership is characterized by the distribution, responsibilities, and behavioral functions. For the organization to be effective, leadership must believe in enterprise principles, and be distributed throughout the CFTs despite the constant turnover of personnel. SWE leadership is fulfilling its responsibilities in executing strategy by ensuring constant communication with its members through monthly meetings. Leadership is demonstrating the correct behavioral functions necessary to evolve as an organization. SWE has established governing documents and standard practices in an attempt to provide consistent behavior across the organization however, the future direction of SWE will be determined by its leadership.

This analysis forms the basis for conclusions, recommendations, and further areas of research.

THIS PAGE INTENTIONALLY LEFT BLANK

V. CONCLUSIONS AND RECOMMENDATIONS

A. INTRODUCTION

This project provides an external look at the Surface Warfare Enterprise and how it has implemented enterprise management practices through organization, governance, and leadership. It also attempted to identify if any changes in resource allocation can be attributed to the enterprise practices of the SWE. The project first presented a background of how process improvement initiatives led to the development of the navy enterprise management system, and how the SWE fit into that framework. It then reviewed literature related to concepts of enterprise management, presented the SWE through review of archival documents and data gathered from interviews with key SWE personnel, and analyzed the relationship of those findings to the framework of concepts discussed in corporate literature.

The project was able to identify how enterprise management was first implemented, and through research of SWE history, was able to determine how it has developed. It details how SWE is organized, governed, and led. It was able to identify some attributed effect on resource allocation; however, it was unable to sufficiently answer the supporting research questions. The data gathered focused primarily on establishing a firm understanding of the various relationships and processes of the SWE organization. Once data for the primary research question was analyzed, it was realized that the supporting questions were not appropriately asked or adequately addressed during the research process. The correct approach to determine SWE's effect on resources has been identified and will be recommended for further research.

The project will conclude with recommendations to maximize SWE's influence, and suggestions for further research. It is intended that this project will provide a greater awareness of the SWE mission, and assist leadership in the further development of the organization.

B. CONCLUSIONS

The conclusions of this project are presented in the context of the research questions asked in Chapter I.

1. Primary Research Question:

How was enterprise management implemented in Surface Warfare Enterprise; how is it organized, governed and led?

SWE has applied enterprise management practices through organization, governance, and leadership. Most of these applications correspond to the models and concepts presented in the literature. These models have also identified areas of inconsistency and potential challenges unique to SWE that must be managed carefully.

a. Organization

The horizontal application of cross-functional management has been very effective in increasing cross-collaboration of important stakeholders and decision-makers. Cross-functional teams have the right composition of experience and resources to produce the appropriate outputs. This cross-functional effectiveness is also consistent with the management structure model. From a strategic level of management, SWE has been able to produce an effective strategic plan that is being pushed to lower levels of the enterprise. The lateral level of management (CFTs) has been able to take that strategy and formulate annual plans that will deliver outputs in support of the organizations strategic direction. However, when applying this model, the area of inconsistency with how SWE is organized is seen at the daily management level. SWE's structure suggests the lowest level of the SWE is the N40 support staff, and staffs of the CFTs. How deckplate sailors fit in the organization is largely unclear. The analysis identifies that they are recipients of the SWE decision-making process, but if the organizations measurement of success is a warship ready for tasking, the sailors who provide the daily work output to get a warship ready for that tasking need to be aligned with SWE goals. This is also consistent when applying the main thing model to SWE's linking of the people element. The current gap in knowledge and understanding of SWE strategy, mission, and in some cases, its very existence within lower levels of the surface navy,

suggests the organization has not yet been able to fully align all levels of the surface navy in pursuit of one common goal. The models suggest that there must be an understanding of strategy and goals at the lowest level of any organization. If sailors are part of the output, then they are a direct part of the organization and must know how the quality of their output is contributing to the larger organization.

b. Governance

How the surface board is structured does not necessarily determine how effective it will be. The determining factor that drives the performance of the board is the behavior and social dynamic between its members. The surface board has been the SWE's largest success. Since 2005, it has grown in membership along with the addition of CFTs. The behavior and processes of the surface board is consistent with practices suggested in the literature review. The consistency of board meetings, and the culture of open and honest communication among all stakeholders, no matter the rank, has been the key to SWE's ability in developing a holistic style of management. An area of concern is the latitude given for membership and the constant rotations of surface board leaders. High levels of rotation are a product of navy culture and are often a beneficial as new sets of eyes come into an organization. However, corporate practices would argue that organization governance must be stable. This is a challenge that SWE must recognize and continually address. Another area of SWE governance that is not consistent with corporate governance practices is the necessary process of external performance evaluations. SWE does not have an impartial process to determine how well the surface board is performing, and if certain social dynamics are sub-optimizing its potential outputs.

c. Leadership

SWE's understanding of the leadership responsibilities, and behaviors required to develop the enterprise organization is consistent with recommendations from literature. The current leadership in the SWE executive committee and surface board believes in the enterprise management approach, and what the organization is trying to achieve. This distribution of leadership is important to the collaboration between all the

major stakeholders. SWE recognizes the need for leaders who are willing to be collaborative in their leadership approach. The challenge faced by SWE is the added complexity of constant leadership rotations, which are not necessarily common to corporate enterprises. These rotations can affect the consistency of action across the leadership of the SWE. To ensure the right distribution, SWE is faced with the challenge of managing surface board membership, and ensuring the right type of leaders are present in the CFTs.

2. Supporting Research Questions

- To what extent have there been changes in resource allocation?
- Can these changes in resource allocation be attributed to SWE?

This is best answered by addressing both questions together. This project identified some changes in the way resources have been allocated, specifically money and manning. A specific example was given on how SWE leadership identified the negative effect of optimal manning initiatives and has re-allocated the billets that were taken away in order to reverse the negative effect of these optimal manning initiatives. It also identified how commands with certain funding control have been brought into the influence of the enterprise. Determining the resource effects beyond these examples was difficult, and the research approach did not support gathering the right data to sufficiently answer and analyze the supporting questions. SWE is not an entity that has clear control of identifiable resources. Instead it seeks to influence the budgeting of resources at higher levels. However, determining the precise effect of this influence is complicated to measure. Once the SWE Executive Director receives inputs, and establishes what the priorities are going to be for that specific budget cycle, it is sent further up the process where competition across the larger enterprise determines how it is allocated. The information and priorities generated by the SWE may not be the factors taken into account by the policy makers. Although very useful to the surface navy, the priorities established by SWE may not have a consistent measure of effect in a system where decisions are often based on politics.

Since this the project lacked sufficient data to identify specific changes in systematic resource allocation that can be attributed to SWE, it was not able to present an adequate analysis. This is largely due to asking the wrong supporting questions. A more appropriate research question, which is recommended for further research, is how are the priorities of the SWE influencing the systematic budgeting process of resource allocation and what specific changes in resource allocations can be attributed to SWE. A comparison of the priorities that are established by SWE, and what is actually put in the navy's POM and budgeted for is needed. This approach would better determine the effect of SWE's strategy of influence on the systematic process of resource allocation at the budget level. This research approach must involve the leadership of SWE's Strategic Financial Management Team as the main source of data. Research on this matter must also take place outside of CNSF. N8 and N86 must also be a source of data in order to have a comparison between SWE, and the larger budgeting system.

C. RECOMMENDATIONS

The following recommendations were reached based on observations made while conducting research for this project. They were made after a detailed review of SWE documents and interviews of key SWE. A literature review examined enterprise management materials and was a key tool to the analysis conducted. The recommendations reached reflect the author's opinions only and not the opinions of the United States Navy.

1. Allow Unit Level Leadership More Exposure to the Surface Board

Providing division officers attending SWOS, department heads attending DH school, and PCOs and PXOs the ability to view the surface board in action through VTC would give greater knowledge and exposure of SWE's mission to lower levels of the surface navy. This would allow unit leaders to see how management of resources at the lowest levels impacts the larger strategy of the surface force. It will also put trust in the organization by permitting more transparency of the enterprise decision making process. This recommendation was reached by observations made while attending a surface board

meeting. Our analysis presented the value of these meetings, and a logical conclusion is to allow more exposure to junior officers while attending SWOS.

2. Discontinue Use of the Enterprise Maturity Model as the Organizations Self-Audit Tool

The EMM was a tool used by Thomas Group to help the development of the SWE organization when it was first beginning as an organization. Since then, the culture of SWE has changed. The matrix is very extensive and complex. The matrix should be scaled down to include a realistic number of carefully chosen measurements that does not involve such a large analysis effort. Another option would be to incorporate the enterprise improvement plans into the annual plan deliverables of the organization. This would provide more frequent updates on the state of enterprise improvements or barriers to development. This recommendation is derived from a careful examination of the EMM.

3. Establish a Governing Board Performance Observation Process Across all Warfare Enterprises

The success of the SWE is closely attributed to the performance of the surface board. Can this board function more efficiently? Have other enterprises developed more effective and cost efficient processes? A panel should be created that looks at each warfare enterprise governing body for possible lessons learned that could be used in other warfare areas. This would provide greater collaboration of enterprise practices through the navy enterprise. Panels would be made up of administrative support staff from each enterprise. Since these members are not stakeholders in any enterprise, they can remain impartial to new ideas. This panel would observe and report any findings to each enterprise commander. This recommendation is based on best practices in enterprise management as seen by the authors. A panel of impartial officers may discover new ideas that would add to the overall success of the organization.

D. SUGGESTIONS FOR FURTHER RESEARCH

This report has established the groundwork from which further research on SWE can be conducted. Determining SWE's ability or inability to affect the allocation of resources at the budget level will clarify the influence that SWE priorities actually have on the larger budgeting process. How this research should be conducted was provided in section B of this chapter.

Ultimately, the success of SWE is measured by increased readiness through the surface fleet. Further research should compare fleet readiness data such as TFOM, MFOM or other PESTO scores with O&M funding data. If O&M spent per ship decreases and readiness levels increase, then that would demonstrate a positive measurable impact of SWE. This would also determine if enterprise behavior at a strategic level was able to change behavior at the unit level.

The link between SWE and the fleet is important to address further as well. This project identified the knowledge gap present at the deckplate level. The current SWE strategic communications plan is attempting to expand knowledge of the SWE throughout the surface navy. Research can be conducted that evaluates whether or not the communications plan was successful in reaching the deckplate level. Interviewing and surveying junior personnel, mainly division officers and chiefs serving afloat, would be the best research approach for this question.

THIS PAGE INTENTIONALLY LEFT BLANK

APPENDIX A

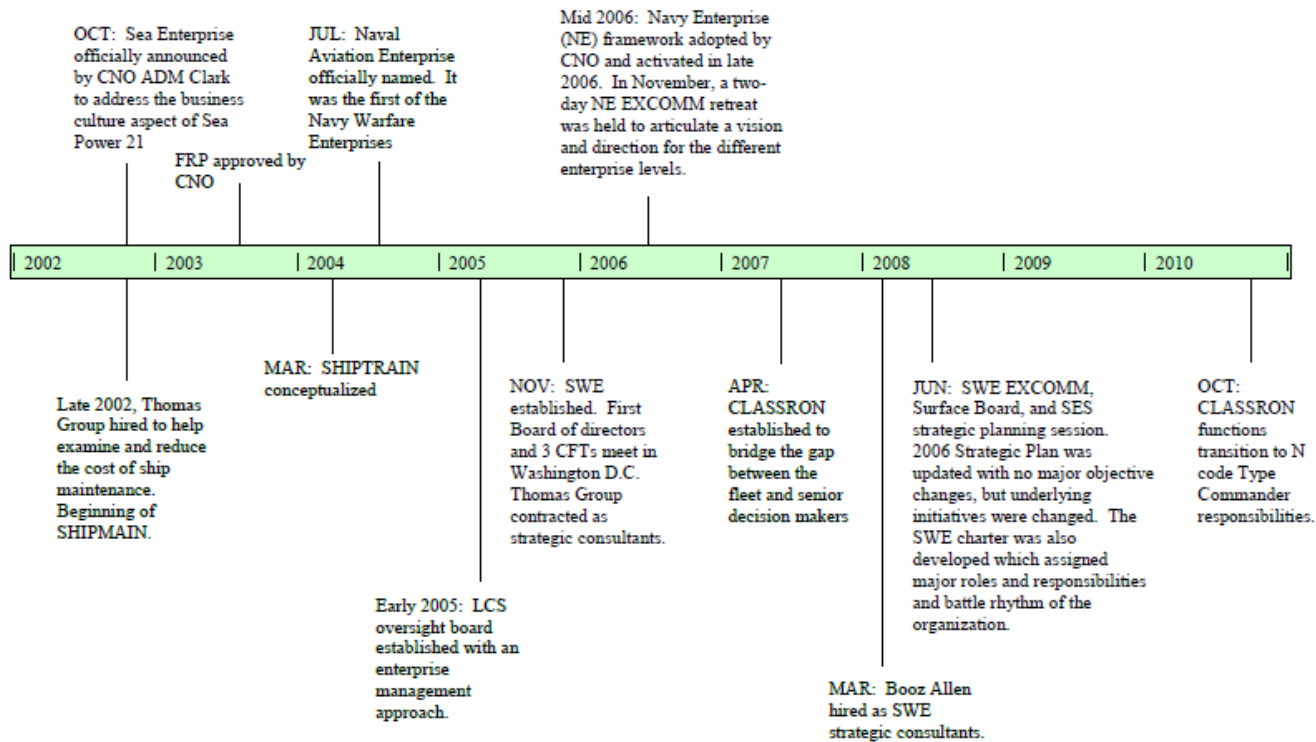
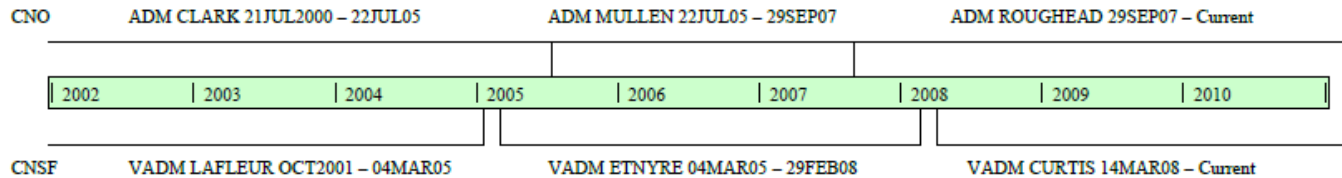

THIS PAGE INTENTIONALLY LEFT BLANK

APPENDIX B

Level	I	II	III	IV	V
Enterprise Mgmt.					
Change Management Organization	Enterprise Leadership Team prioritization of tasks and change management has begun. There is some collaboration between stakeholders.	Major core business processes have an Enterprise senior level process owner	Multi-functional Enterprise Leadership Team driving CFTs is the organizational construct that manages the Enterprise Leadership process	Organization roles, responsibilities and accountabilities are defined across Enterprise stakeholders in a manner that optimizes CWR	A properly constructed BOD and all subordinate units independently seek to optimize Enterprise performance
Governance	Management processes are clearly identified and have begun improvement throughout the Enterprise	Enterprise Leadership drives a "change friendly" culture and applies a rich set of change management skills	Domain governance is compliant and consistent with the higher Enterprise stds. with utilization of lessons learned	The Enterprise Leadership Team drives execution of an integrated strategy and planning processes	Common metrics package drives Enterprise behaviors and actions on a drumbeat basis
Alignment	Enterprise Vision statements, goals, and objectives exist, are communicated throughout and have begun to govern entity prioritizations and actions	The common metrics package is transparent with goals and objectives clearly defined. There is a clear understanding of driver and result metrics.	All business and support process inputs and outputs are aligned throughout the Enterprise and all Domains	There is broad accountability with time-phased goals and a process to harvest and bank Enterprise results	Enterprise quickly executes defined processes that address dilemmas of funding and recapitalization pressure
Management Process Scope & Boundaries	Management has created a clear set of business rules for managing the Enterprise and identifies the areas out of management scope (e.g. Congressional Funding)	All direct reporting organizations and their portions of processes are subject to Enterprise management	Enterprise manages all aspects of key leveraged value stream processes, and strongly, collaboratively influences those subprocesses not in their direct chain of command	Enterprise strongly, collaboratively influences all key, leveraged enabling and supporting processes, including those subprocesses not in their direct chain of command	Enterprise formally defines and manages the funding, savings harvest, and savings banking processes
Problem / Barrier Resolution	Business Process and Culture Barriers are identified and prioritized relative to impact on the Enterprise goals and objectives	Senior Flag Officers accept responsibility for and act on removing Business Process and Cultural Barriers	Comprehensive plan is developed for removal of Culture Barriers and agreed to by all Stakeholders	Some Culture Barriers are removed and change is visible throughout the Enterprise	Barrier removal is the improvement culture of the Enterprise
Strategy & Planning	Both current realities and a clear vision of the future exist and govern the strategic planning process	Strategic planning process identifies and clearly articulates Enterprise critical conflicting issues and the initial steps required to resolve	Strategic process generates a strategic and tactical plan that resolves the Enterprise critical issues and meets customer needs	Integrated strategic Financial Model is Enterprise-focused and includes all domains and all sources and applications of funds and all improvement initiatives	Enterprise strategic process cascades to all subordinate domains & supporting entities, and directs decision making models for investment and resource allocation
Execution & Results					
Process Driven	All leveraged value stream and enabling business processes are mapped, characterized and transparent. The critical inputs for successful process outputs are identified.	Key business processes are identified and force-ranked by objectively defined leveraged improvement opportunity (relative to achieving goals and objectives / CWR)	Processes & their outputs are the primary means to measure & communicate Enterprise activity, status, progress & barriers, and to identify and drive required changes	All leveraged business process intersections have well-defined inputs, outputs and the required timing, cost and quality	All processes across the Extended Enterprise, and their intersections, operate effectively and are customer driven
Metrics - drivers and results	Hierarchical, business process metrics are used, on a drumbeat basis, as the foundation for identifying barriers and driving org. behaviors & priorities. Metrics include both leading indicators (drivers) and results.	A robust structure exists for metric data collection, metric calculation, prioritization, and accurate and timely metric reporting for all Domains and for the Enterprise	Hierarchical metrics are insightful and directive and drive productivity improvements	There is a single Enterprise driven set of metrics used by the Enterprise and all subordinate units	All Enterprise units have achieved full Metrics Infrastructure maturity. All Enterprise levels are managed with hierarchical, transparent, common and linked metrics. Adaptive planning capability exists.
Cost Management	Enterprise is financially defined, costs collected and analyzed and Financial Cost Planning Processes are defined and initiated.	Financial Planning Processes used to start driving productivity improvements and a routine reporting process has been initiated	A CFO organization exists. Each Business Process owner is knowledgeable of and held accountable for planning and improving productivity. Productivity can be measured at the level needed by the org.	Subordinate level Financial Models exist and are utilized at those levels. Cost reporting systems are hierarchical and timely. Both these processes continue to drive Enterprise productivity improvements.	CFO organization is integrated with the operators who effectively utilize the financial processes to make the strategic and structural decisions necessary to recapitalize the Navy.
Improvement Process	A barrier escalation process exists and is active throughout the Enterprise	Fully empowered Cross Functional Teams and Barrier Removal Teams are actively managing process improvement	A formal Lessons Learned process is in place and used to sustain and transfer improvement efforts across the Enterprise	The Enterprise Leadership Team sets Enterprise Leadership goals and priorities to optimize results across all Domains processes. Cross-Process & Domain Impact charts exist to guide goals & priorities	Enterprise strategy and a "Continuous Architecture" govern the improvement process goals and resources
Tools & Methodology	The Enterprise uses a common set of tools and methodology for managing its business improvement activity. A formal communications process exists.	Training process exists to provide new Enterprise people the tools and education needed to be a contributing member of the Enterprise	Monthly Enterprise Leadership Team updates clearly evidence the adoption and use of the methodology and tools	Lessons Learned concerning the management tools and methodology are shared across the Enterprise as a normal business practice	A cadre of "Internal Resultants" are actively leading process improvement throughout the Enterprise
Results Evidenced	Synergy is evident throughout the Enterprise and all Domains as Cross Functional Teams are achieving visible, positive results in process improvement	Warfighters and Fleet collaboratively drive behavioral changes in other Domains cost, priorities, and funds allocations	There is a demonstrated ability to rapidly and cost-effectively respond to changes in mission directed by the Navy or FFC Enterprises	The Enterprise and all Domains forecast and regularly achieve productivity improvements	The Enterprise has achieved Cost-Wise Readiness goals and has generated the recapitalization funds. The Enterprise sets new goals.

THIS PAGE INTENTIONALLY LEFT BLANK

LIST OF REFERENCES

- Burton, Terrance, and John Moran. *The Future Focused Organization: Complete Organizational Alignment for Breakthrough Results*. Englewood Cliffs, NJ: Prentice Hall, 1995.
- Cairnes, Margot. *Boardrooms That Work: A Guide to Board Dynamics*. Sydney: Australian Institute of Company Directors, 2003.
- Commander Naval Surface Forces. *Surface Warfare Enterprise: SWE 101 Training Presentation*. San Diego: Commander Naval Surface Forces, 2010.
- Commander, Naval Surface Forces. *Surface Warfare Enterprise 2010 Strategic Plan update 4*. San Diego: Commander Naval Surface Forces, 2010.
- Commander, Naval Surface Forces. *Surface Warfare Enterprise Charter*. San Diego: Commander, Naval Surface Forces, 2010.
- Commander, Naval Surface Forces. *Surface Warfare Enterprise Process Presentation*. San Diego: Commander, Naval Surface Forces, 2008.
- Commander, Naval Surface Forces. *SWE 2008 Strategic Plan*. San Diego: Commander, Naval Surface Forces, 2008.
- Congress, U.S. *Statement of Admiral J.C. Harvey, JR Commander, U.S. Fleet Forces Command; VADM William Burke Deputy Chief of Naval Operations For Fleet Readiness and Logistics; VADM Kevin McCoy Commander, Naval Sea Systems Command*. Congressional Testimony, Washington D.C.: House Armed Services Committee, 2010.
- Curtis, D.C., interview by Brandon Castle and James Massie. *Commander, Naval Surface Forces* (September 15, 2010).
- Dimancescu, Dan. *The Seamless Enterprise: Making Cross Functional Management Work*. Essex Junction, VT: Oliver Wright Publications, 1992.
- DiMascio, Jen. *Gates Gears up for Cuts Fight*. June 17, 2010.
<http://www.politico.com/news/stories/0610/38643.html> (accessed August 10, 2010).
- Enterprise, Navy. *Navy Enterprise*. <http://www.navyenterprise.navy.mil/about/why.aspx> (accessed July 29, 2010).

- Ewing, Philip. "USN's Lean Manning Backlash." *Defense News*, 2010: 1.
- Kochendorfer, John, interview by Brandon Castle and James Massie. *Surface Warfare Enterprise Executive Assistant* (September 14, 2010).
- Labovitz, George, and Victor Rosansky. *The Power of Alignment: How Great Companies Stay Centered and Accomplish Extraordinary Things*. USA: John Wiley and Sons, 1997.
- Malatino, Raymond. "The NAVAIR TQM Revolution." *Annual Quality Congress*, 1991: 40-45.
- Massenburg, Wally. *The Value of Enterprise Behavior*. Presentation, Lemoore, CA: Commander, Naval Air Systems command, 2005.
- McPherson, Darren, interview by Brandon Castle and James Massie. *Commanding officer USS Sterett (DDG 104)* (September 15, 2010).
- Meek, Gordon. *Center for Navy Business Excellence: A Catalyst for Navy Business Transformation*. Master's thesis, Monterey: Naval Postgraduate School, 2005.
- Naval Research Advisory Committee. *Optimized Surface Ship Manning*. Washington D.C.: Office of the Assistant Secretary of the Navy (Research, Development and Acquisition, 2000).
- Naval Sea Systems Command. *Navy Surface Ship Maintenance-Modernization Planning Presentation*. Washington D.C.: Naval Sea Systems Command, 2006.
- Opsal, Peter, interview by Brandon Castle and James Massie. *Booz Allen Hamilton Lead Associate* (September 14, 2010).
- Perkins, Sam. *Navy Enterprise Transformation: Working for the Greater Good*. Washington D.C.: Babson Executive, 2007.
- Peterka, Peter. *6 Six Sigma*. December 27, 2008. <http://6sixsigma.com/index.php/Lean-Six-Sigma/Lean-Six-Sigma-and-the-Navy.html> (accessed June 28, 10).
- Riposo, Jessie, et al. *Navy Enterprises, Evaluating Their Role in Planning, Programming, Budgeting and Execution (PPBE)*. gov-sponsored, Santa Monica, CA: RAND Corporation, 2009.
- Smith, Bill, interview by Brandon Castle and James Massie. *Booz Allen Hamilton Consultant* (September 14, 2010).
- Streatfield, Philip J. *The Paradox of Control in Organizations*. London: Routledge, 2001.

- Taylor, Paul. *SHIPTRAIN Revolutionizes Surface Force Training*. Norfolk: Commander, Naval Surface Forces, U.S. Atlantic Fleet, 2004.
- Tonkin, Lea A.P. "Northrop Grumman Newport News: Reaching Out to Suppliers." *Target Magazine*, 2006: 51-56.
- TQM Solutions. *Quality Assurance Solutions*. 2004. <http://www.quality-assurance-solutions.com/TQM-History.html>.
- United States Government Accountability Office. *Military Readiness: Navy's Fleet Response Plan Would Benefit From A Comprehensive Management Approach and Rigorous Testing*. Washington D.C.: Government Accountability Office, 2004.
- U.S. Navy Sea Systems Command. "US Sea Systems Command." *Acquisition Community Connection*. February 01, 2006. <https://acc.dau.mil/CommunityBrowser.aspx?id=46417> (accessed July 25, 10).
- Williams, Robert J. *Evaluation of Naval aviation Enterprise Airspeed's Generation of Measurable Cost Savings and Reinvestment for Recapitalization of the Future Navy and Marine Corps*. Masters thesis, Monterey: Naval Postgraduate School, 2007.
- Yardley, Roland J, Raj Ramon, Jessie Riposo, James Chisea, and John F. Schank. *Impacts of the Fleet Response Plan on Surface Combatant Maintenance*. Washington D.C.: RAND, 2006.

THIS PAGE INTENTIONALLY LEFT BLANK

INITIAL DISTRIBUTION LIST

1. Defense Technical Information Center
Ft. Belvoir, Virginia
2. Dudley Knox Library
Naval Postgraduate School
Monterey, California
3. Vice Admiral D.C. Curtis
Commander, Naval Surface Forces
San Diego, California
4. Captain Brian Drapp
Naval Supply Systems Command
Mechanicsburg, Pennsylvania
5. Commander John Kochendorfer
Surface Warfare Enterprise Executive Assistant
San Diego, California
6. Commander Darren McPherson
Commanding Officer USS Sterett (DDG 104)
FPO AP 96678-1310
7. Lieutenant Commander Lisa Hodgson
Surface Warfare Enterprise Maintenance Analyst
San Diego, California
8. Professor Douglas Brook
Center for Defense Management Reform
Monterey, California
9. Professor Phillip Candreva
Graduate School of Business and Public Policy
Monterey, California